

# FCC Test Report

APPLICANT : CT Asia  
EQUIPMENT : Mobile phone  
BRAND NAME : BLU  
MODEL NAME : Studio 5.0 II  
MARKETING NAME : Studio 5.0 II  
FCC ID : YHLBLUSTUDIO5II  
STANDARD : FCC 47 CFR FCC Part 15 Subpart B  
CLASSIFICATION : Certification

The product was received on Nov. 12, 2013 and testing was completed on Nov. 14, 2013. We, SPORTON INTERNATIONAL (SHENZHEN) INC., would like to declare that the tested sample has been evaluated in accordance with the procedures given in ANSI C63.4-2003 and shown to be compliant with the applicable technical standards.

The test results in this report apply exclusively to the tested model / sample. Without written approval of SPORTON INTERNATIONAL (SHENZHEN) INC., the test report shall not be reproduced except in full.

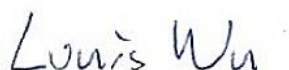

Reviewed by: Louis Wu / Manager

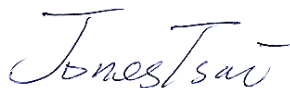

Approved by: Jones Tsai / Manager



## **SPORTON INTERNATIONAL (SHENZHEN) INC.**

**No. 3 Building, the third floor of south, Shahe River west, Fengzeyuan warehouse, Nanshan District, Shenzhen, Guangdong, P.R.C.**



## TABLE OF CONTENTS

REVISION HISTORY.....	3
SUMMARY OF TEST RESULT .....	4
<b>1. GENERAL DESCRIPTION .....</b>	<b>5</b>
1.1. Applicant.....	5
1.2. Manufacturer .....	5
1.3. Feature of Equipment Under Test.....	5
1.4. Product Specification of Equipment Under Test .....	6
1.5. Modification of EUT.....	7
1.6. Test Site .....	7
1.7. Applied Standards .....	7
<b>2. TEST CONFIGURATION OF EQUIPMENT UNDER TEST.....</b>	<b>8</b>
2.1. Test Mode .....	8
2.2. Connection Diagram of Test System .....	10
2.3. Support Unit used in test configuration and system.....	11
2.4. EUT Operation Test Setup.....	12
<b>3. TEST RESULT.....</b>	<b>13</b>
3.1. Test of AC Conducted Emission Measurement .....	13
3.2. Test of Radiated Emission Measurement .....	17
<b>4. LIST OF MEASURING EQUIPMENT .....</b>	<b>22</b>
<b>5. UNCERTAINTY OF EVALUATION .....</b>	<b>23</b>
<b>APPENDIX A. SETUP PHOTOGRAPHS</b>	

## REVISION HISTORY

REPORT NO.	VERSION	DESCRIPTION	ISSUED DATE
FC3N1202	Rev. 01	Initial issue of report	Dec. 13, 2013



### SUMMARY OF TEST RESULT

Report Section	FCC Rule	Description	Limit	Result	Remark
3.1	15.107	AC Conducted Emission	< 15.107 limits	PASS	Under limit 7.06 dB at 15.970 MHz
3.2	15.109	Radiated Emission	< 15.109 limits	PASS	Under limit 0.67 dB at 180.350 MHz for Quasi-Peak

## 1. General Description

### 1.1. Applicant

**CT Asia**

Unit 01, 15/F, Seaview Centre, 139-141 Hoi bun road, Kwun Tong, Kowloon, Hongkong

### 1.2. Manufacturer

**TINNO MOBILE**

4/F., H-3 Building, OCT Eastern Industrial Park. NO.1 Xiangshan East Road., Nan Shan District, Shenzhen, P.R. CHINA

### 1.3. Feature of Equipment Under Test

Product Feature	
<b>Equipment</b>	Mobile phone
<b>Brand Name</b>	BLU
<b>Model Name</b>	Studio 5.0 II
<b>Marketing Name</b>	Studio 5.0 II
<b>FCC ID</b>	YHLBLUSTUDIO5II
<b>EUT supports Radios application</b>	GSM/GPRS/EGPRS/WCDMA/HSPA WLAN 2.4GHz 802.11b/g/n HT20/HT40 Bluetooth v3.0 + EDR Bluetooth v4.0
<b>HW Version</b>	V1.1
<b>SW Version</b>	BLU_D532a_V03_GENERIC
<b>EUT Stage</b>	Identical Prototype

**Remark:** The above EUT's information was declared by manufacturer. Please refer to the specifications or user's manual for more detailed description.

### 1.4. Product Specification of Equipment Under Test

Product Specification subjective to this standard	
<b>Tx Frequency</b>	GSM850 : 824.2 MHz ~ 848.8 MHz GSM1900 : 1850.2 MHz ~ 1909.8MHz WCDMA Band V : 826.4 MHz ~ 846.6 MHz WCDMA Band IV : 1712.4 MHz ~ 1752.6 MHz WCDMA Band II : 1852.4 MHz ~ 1907.6 MHz 802.11b/g/n: 2412 MHz ~ 2462 MHz Bluetooth: 2402 MHz ~ 2480 MHz
<b>Rx Frequency</b>	GSM850 : 869.2 MHz ~ 893.8 MHz GSM1900 : 1930.2 MHz ~ 1989.8 MHz WCDMA Band V : 871.4 MHz ~ 891.6 MHz WCDMA Band IV : 2112.4 MHz ~ 2152.6 MHz WCDMA Band II : 1932.4 MHz ~ 1987.6 MHz 802.11b/g/n: 2412 MHz ~ 2462 MHz Bluetooth: 2402 MHz ~ 2480 MHz GPS : 1.57542 GHz
<b>Antenna Type</b>	WWAN : Fixed Internal Antenna WLAN : PIFA Antenna Bluetooth : PIFA Antenna
<b>Type of Modulation</b>	GSM: GMSK GPRS: GMSK EDGE(MCS 0-4): GMSK / (MCS 5-9): 8PSK WCDMA: QPSK (Uplink) HSDPA: QPSK (Uplink) HSUPA: QPSK (Uplink) 802.11b : DSSS (DBPSK / DQPSK / CCK) 802.11g/n : OFDM (BPSK / QPSK / 16QAM / 64QAM) Bluetooth 4.0 - LE : GFSK Bluetooth 3.0 EDR : GFSK, $\pi/4$ -DQPSK, 8-DPSK GPS : BPSK

### 1.5. Modification of EUT

No modifications are made to the EUT during all test items.

### 1.6. Test Site

<b>Test Site</b>	SPORTON INTERNATIONAL (SHENZHEN) INC.		
<b>Test Site Location</b>	No. 3 Building, the third floor of south, Shahe River west, Fengzeyuan warehouse, Nanshan District, Shenzhen, Guangdong, P.R.C. TEL: +86-755- 3320-2398		
<b>Test Site No.</b>	<b>Sporton Site No.</b>		<b>FCC Registration No.</b>
	CO01-SZ	03CH01-SZ	831040

### 1.7. Applied Standards

According to the specifications of the manufacturer, the EUT must comply with the requirements of the following standards:

- ♦ FCC 47 CFR FCC Part 15 Subpart B
- ♦ ANSI C63.4-2003

**Remark:** All test items were verified and recorded according to the standards and without any deviation during the test.

## 2. Test Configuration of Equipment Under Test

### 2.1. Test Mode

The EUT has been associated with peripherals pursuant to ANSI C63.4-2003 and configuration operated in a manner tended to maximize its emission characteristics in a typical application.

Frequency range investigated: conduction (150 kHz to 30 MHz), radiation (30MHz to the 5th harmonic of the highest fundamental frequency or to 40 GHz, whichever is lower).

The following tables are showing the test modes as the worst cases and recorded in this report.

Item	EUT Configuration	Test Condition		
		EMI AC	EMI RE<1G	EMI RE≥1G
1.	Charging Mode (EUT with adapter)	☒	☒	Note 1
2.	Data application transferred mode (EUT with notebook)	☒	☒	☒

**Abbreviations:**

- EMI AC: AC conducted emissions
- EMI RE ≥ 1G: EUT radiated emissions ≥ 1GHz
- EMI RE < 1G: EUT radiated emissions < 1GHz

**Note 1:** Testing for this mode is not required or not the worst case.

**Remark:** For signal above 1GHz, the worst case was test item 2.



Test Items	EUT Configure Mode	Function Type
AC Conducted Emission	1/2	<p>Mode 1: GSM850 Idle + Bluetooth Idle + WLAN Idle + USB Cable (Charging from Adapter) + Earphone + Camera + SIM1 &lt;Fig. 1&gt;</p> <p>Mode 2: GSM1900 Idle + Bluetooth Idle + WLAN Idle + USB Cable (Charging from Adapter) + Earphone + MPEG4 + SIM1 &lt;Fig. 1&gt;</p> <p>Mode 3: WCDMA Band V Idle + Bluetooth Idle + WLAN Idle + USB Cable (Data Link with Notebook) + Earphone + GPS Rx + SIM1&lt;Fig. 2&gt;</p>
Radiated Emissions < 1GHz	1/2	<p>Mode 1: GSM850 Idle + Bluetooth Idle + WLAN Idle + USB Cable (Charging from Adapter) + Earphone + Camera + SIM1 &lt;Fig. 1&gt;</p> <p>Mode 2: GSM1900 Idle + Bluetooth Idle + WLAN Idle + USB Cable (Charging from Adapter) + Earphone + MPEG4 + SIM1 &lt;Fig. 1&gt;</p> <p>Mode 3: WCDMA Band V Idle + Bluetooth Idle + WLAN Idle + USB Cable (Data Link with Notebook) + Earphone + GPS Rx + SIM1&lt;Fig. 2&gt;</p>
Radiated Emissions ≥ 1GHz	2	<p>Mode 1: WCDMA Band V Idle + Bluetooth Idle + WLAN Idle + USB Cable (Data Link with Notebook) + Earphone + GPS Rx + SIM1&lt;Fig. 2&gt;</p>
<p><b>Remark:</b></p> <ol style="list-style-type: none"> <li>1. The worst case of AC is mode 3; only the test data of this mode is reported.</li> <li>2. The worst case of RE &lt; 1G is mode 3; only the test data of this mode is reported.</li> <li>3. Link with Notebook means data application transferred mode between EUT and Notebook.</li> </ol>		

## 2.2. Connection Diagram of Test System

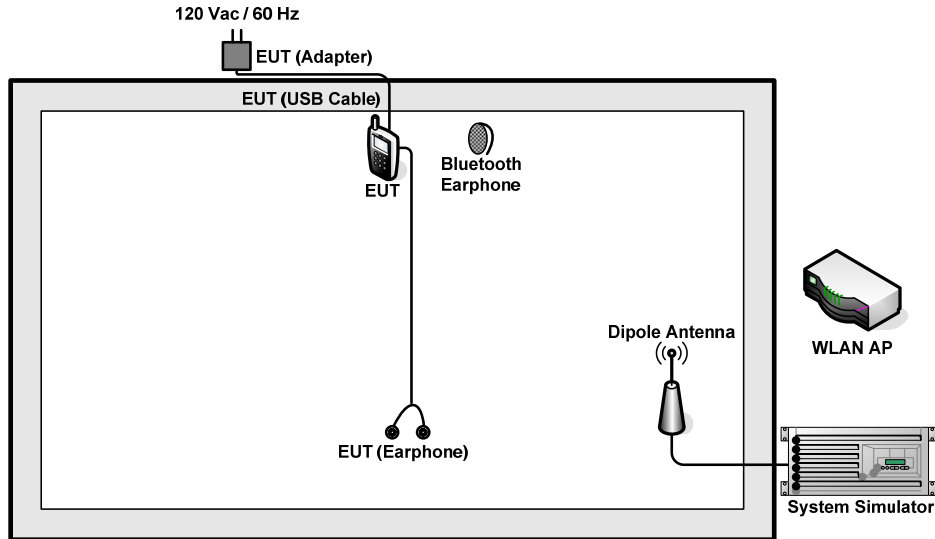

<Fig. 1>

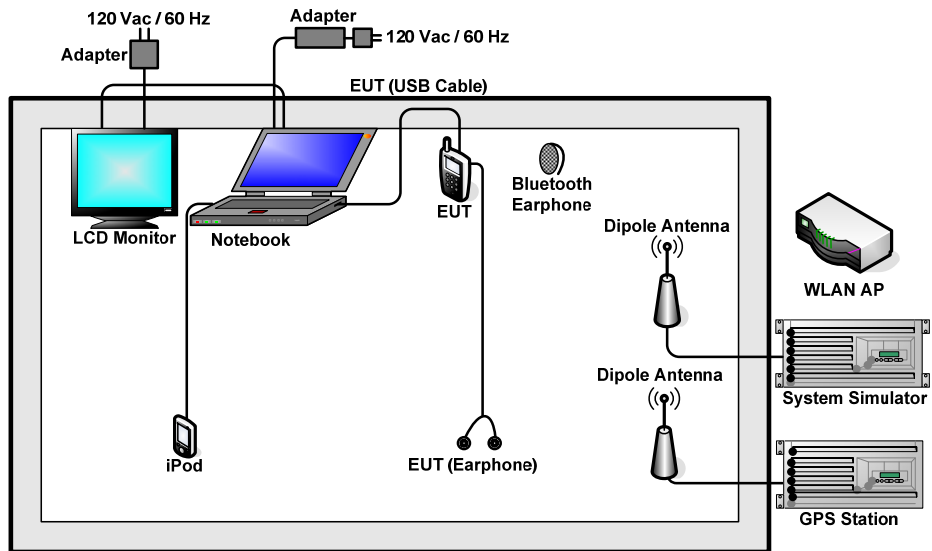

<Fig. 2>

### 2.3. Support Unit used in test configuration and system

Item	Equipment	Trade Name	Model Name	FCC ID	Data Cable	Power Cord
1.	System Simulator	Agilent	E5515C	N/A	N/A	Unshielded, 1.8 m
2.	WLAN AP	D-link	DIR-815	KA2IR815A1	N/A	Unshielded, 1.8m
3.	GPS Station	ADIVIC	MP9000	N/A	N/A	Unshielded, 1.8 m
4.	WLAN AP	D-Link	DIR-628	KA2DIR628A2	N/A	Unshielded, 1.8 m
5.	Bluetooth Earphone	Nokia	BH-108	FCC DoC	N/A	N/A
6.	Notebook	DELL	Vostro1440	FCC DoC	N/A	AC I/P: Unshielded, 1.2m DC O/P: Shielded, 1.8 m
7.	Notebook	Lenovo	G480	N/A	N/A	AC I/P: Unshielded, 0.8 m DC O/P: Shielded, 1.8 m
8.	Monitor	DELL	IN1940MWB	FCC DoC	shielded, 1.2 m	Unshielded, 1.8 m
9.	iPod	Apple	MC690 ZP/A	FCC DoC	Shielded, 1.2 m	N/A



## **2.4. EUT Operation Test Setup**

The EUT was in GSM or WCDMA idle mode during the testing. The EUT was synchronized to the BCCH, and was in continuous receiving mode by setting system simulator's paging reorganization.

At the same time, the EUT was attached to the Bluetooth earphone or WLAN AP, and the following programs installed in the EUT were programmed during the test.

1. Data application is transferred between Laptop and EUT via USB cable.
2. Turn on GPS function to make the EUT receive continuous signals from GPS station.
3. Execute "Video Player" to play MPEG4 files.
4. Turn on camera to capture images.
5. Execute "H Pattern" to show H Pattern via VGA Cable on the Monitor.

### 3. Test Result

#### 3.1. Test of AC Conducted Emission Measurement

##### 3.1.1 Limits of AC Conducted Emission

For equipment that is designed to be connected to the public utility (AC) power line, the radio frequency voltage that is conducted back onto the AC power line on any frequency or frequencies within the band 150 kHz to 30 MHz shall not exceed the limits in the following table.

Frequency of emission (MHz)	Conducted limit (dBuV)	
	Quasi-peak	Average
0.15-0.5	66 to 56*	56 to 46*
0.5-5	56	46
5-30	60	50

\*Decreases with the logarithm of the frequency.

##### 3.1.2 Measuring Instruments

The measuring equipment is listed in the section 4 of this test report.

##### 3.1.3 Test Procedure

1. The EUT was placed 0.4 meter from the conducting wall of the shielding room was kept at least 80 centimeters from any other grounded conducting surface.
2. Connect EUT to the power mains through a line impedance stabilization network (LISN).
3. All the support units are connecting to the other LISN.
4. The LISN provides 50 ohm coupling impedance for the measuring instrument.
5. The FCC states that a 50 ohm, 50 microhenry LISN should be used.
6. Both sides of AC line were checked for maximum conducted interference.
7. The frequency range from 150 kHz to 30 MHz was searched.
8. Set the test-receiver system to Peak Detect Function and specified bandwidth with Maximum Hold Mode.

### 3.1.4 Test Setup

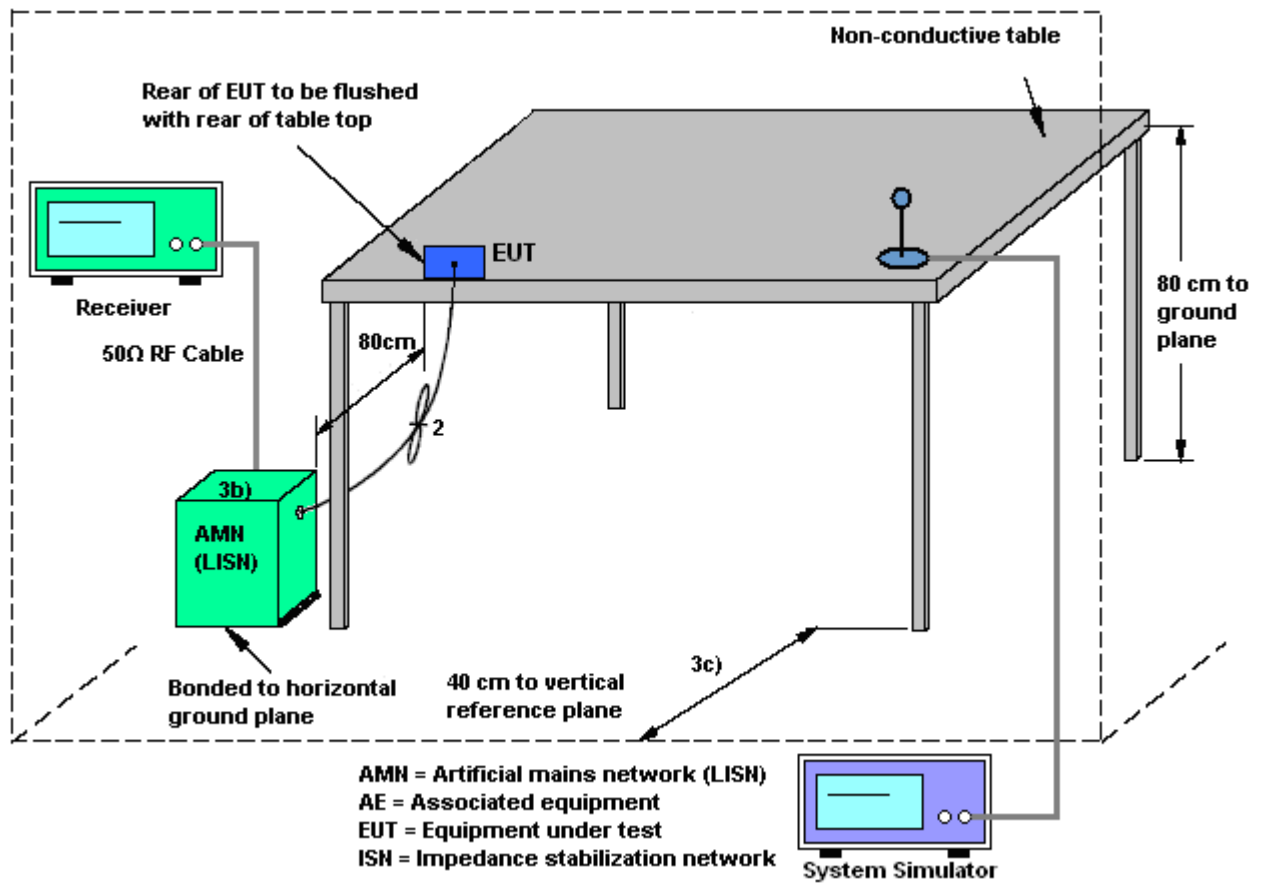

3.1.5 Test Result of AC Conducted Emission

Test Mode :	Mode 3	Temperature :	24~25°C
Test Engineer :	Henry Chen	Relative Humidity :	53~54%
Test Voltage :	120Vac / 60Hz	Phase :	Line
Function Type :	WCDMA Band V Idle + Bluetooth Idle + WLAN Idle + USB Cable (Data Link with Notebook) + Earphone + GPS Rx + SIM1		

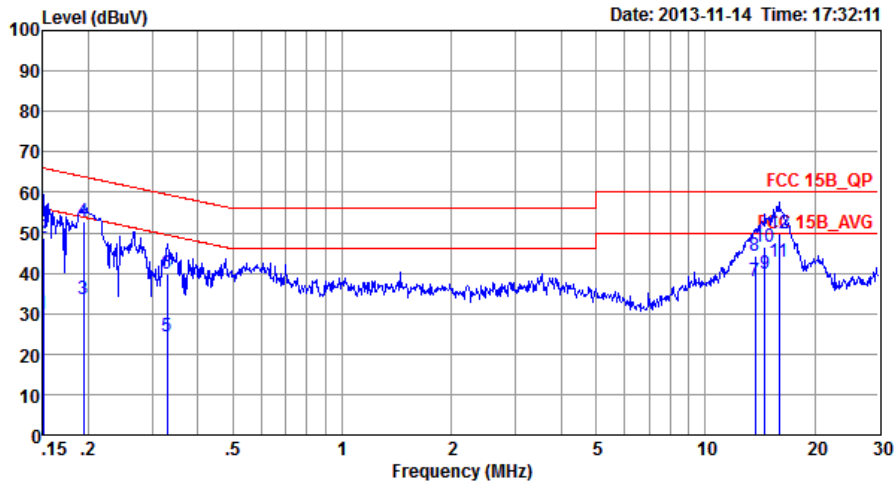

Site : CO01-SZ  
 Condition: FCC 15B\_QP LISN\_L\_20130328 LINE  
 Project : (FC)3N1202  
 Mode : Mode 3

	Freq	Level	Over Limit	Limit Line	Read Level	LISN Factor	Cable Loss	Remark
	MHz	dBuV	dB	dBuV	dBuV	dB	dB	
1	0.15	29.92	-26.08	56.00	19.50	0.06	10.36	Average
2	0.15	48.72	-17.28	66.00	38.30	0.06	10.36	QP
3	0.19	33.55	-20.29	53.84	23.20	0.07	10.28	Average
4	0.19	52.75	-11.09	63.84	42.40	0.07	10.28	QP
5	0.33	24.50	-24.94	49.44	14.20	0.11	10.19	Average
6	0.33	39.80	-19.64	59.44	29.50	0.11	10.19	QP
7	13.70	37.86	-12.14	50.00	26.60	0.86	10.40	Average
8	13.70	44.26	-15.74	60.00	33.00	0.86	10.40	QP
9	14.59	39.81	-10.19	50.00	28.50	0.89	10.42	Average
10	14.59	46.31	-13.69	60.00	35.00	0.89	10.42	QP
11 *	15.97	42.94	-7.06	50.00	31.50	0.99	10.45	Average
12	15.97	49.84	-10.16	60.00	38.40	0.99	10.45	QP



Test Mode :	Mode 3	Temperature :	24~25°C
Test Engineer :	Henry Chen	Relative Humidity :	53~54%
Test Voltage :	120Vac / 60Hz	Phase :	Neutral
Function Type :	WCDMA Band V Idle + Bluetooth Idle + WLAN Idle + USB Cable (Data Link with Notebook) + Earphone + GPS Rx + SIM1		

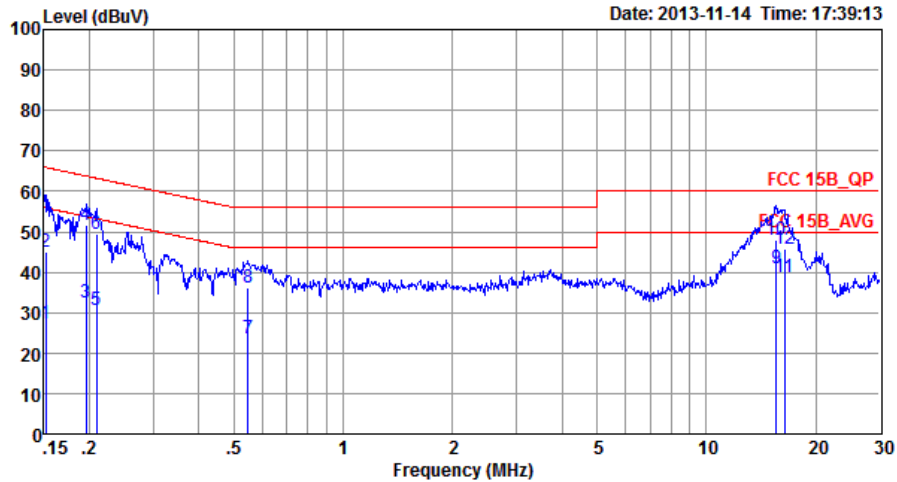

Site : CO01-SZ  
 Condition: FCC 15B\_QP LISN\_N\_20130328 NEUTRAL  
 Project : (FC)3N1202  
 Mode : Mode 3

	Freq	Level	Over Limit	Limit Line	Read Level	LISN Factor	Cable Loss	Remark
	MHz	dBuV	dB	dBuV	dBuV	dB	dB	
1	0.15	27.20	-28.71	55.91	16.80	0.04	10.36	Average
2	0.15	45.20	-20.71	65.91	34.80	0.04	10.36	QP
3	0.20	32.52	-21.28	53.80	22.20	0.04	10.28	Average
4	0.20	51.62	-12.18	63.80	41.30	0.04	10.28	QP
5	0.21	30.60	-22.63	53.23	20.30	0.04	10.26	Average
6	0.21	49.60	-13.63	63.23	39.30	0.04	10.26	QP
7	0.55	23.49	-22.51	46.00	13.30	0.04	10.15	Average
8	0.55	35.99	-20.01	56.00	25.80	0.04	10.15	QP
9 *	15.55	40.99	-9.01	50.00	30.00	0.55	10.44	Average
10	15.55	47.99	-12.01	60.00	37.00	0.55	10.44	QP
11	16.40	38.60	-11.40	50.00	27.50	0.62	10.48	Average
12	16.40	45.70	-14.30	60.00	34.60	0.62	10.48	QP



## 3.2. Test of Radiated Emission Measurement

### 3.2.1. Limit of Radiated Emission

The emissions from an unintentional radiator shall not exceed the field strength levels specified in the following table:

Frequency (MHz)	Field Strength (microvolts/meter)	Measurement Distance (meters)
30 – 88	100	3
88 – 216	150	3
216 - 960	200	3
Above 960	500	3

### 3.2.2. Measuring Instruments

The measuring equipment is listed in the section 4 of this test report.

### 3.2.3. Test Procedures

1. The EUT was placed on a turntable with 0.8 meter above ground.
2. The EUT was set 3 meters from the interference receiving antenna, which was mounted on the top of a variable height antenna tower.
3. The table was rotated 360 degrees to determine the position of the highest radiation.
4. The antenna is a Bi-Log antenna and its height is adjusted between one to four meters above ground to find the maximum value of the field strength for both horizontal polarization and vertical polarization of the antenna.
5. For each suspected emission, the EUT was arranged to its worst case and then tune the antenna tower (from 1 m to 4 m) and turntable (from 0 degree to 360 degrees) to find the maximum reading.
6. Set the test-receiver system to Peak Detect Function and specified bandwidth with Maximum Hold Mode.
7. If the emission level of the EUT in peak mode was 3 dB lower than the limit specified, peak values of EUT will be reported. Otherwise, the emission will be repeated by using the quasi-peak method and reported.
8. Emission level (dB $\mu$ V/m) = 20 log Emission level ( $\mu$ V/m)
9. Corrected Reading: Antenna Factor + Cable Loss + Read Level - Preamp Factor = Level

### 3.2.4. Test Setup of Radiated Emission

For radiated emissions from 30MHz to 1GHz

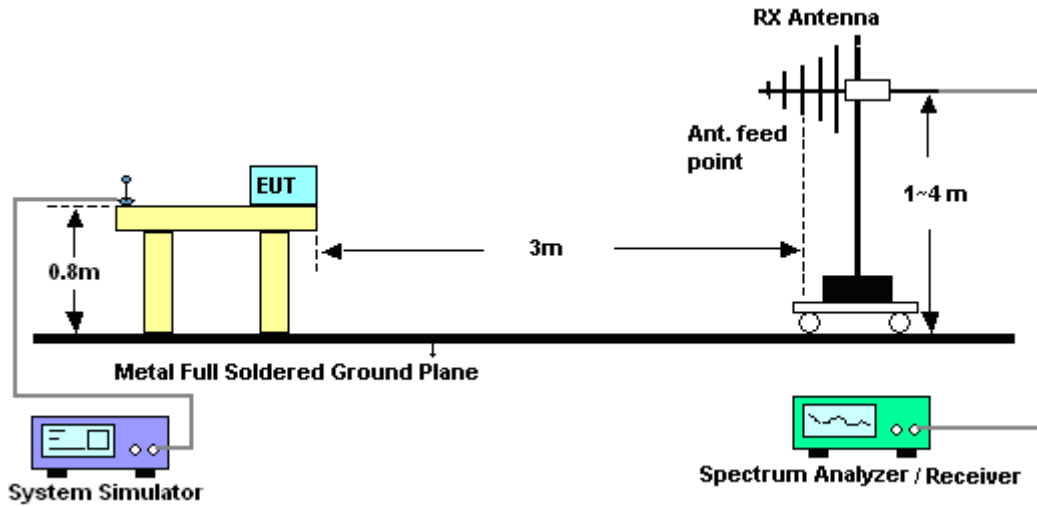

For radiated emissions above 1GHz

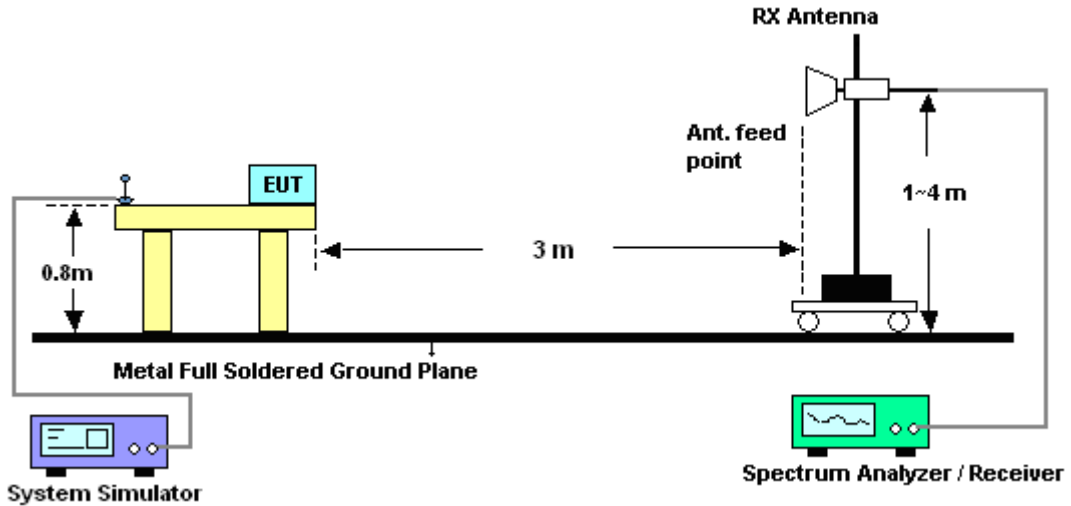



3.2.5. Test Result of Radiated Emission

Test Mode :	Mode 3	Temperature :	24~25°C
Test Engineer :	Leo Liao	Relative Humidity :	48~49%
Test Distance :	3m	Polarization :	Horizontal
Function Type :	WCDMA Band V Idle + Bluetooth Idle + WLAN Idle + USB Cable (Data Link with Notebook) + Earphone + GPS Rx + SIM1		

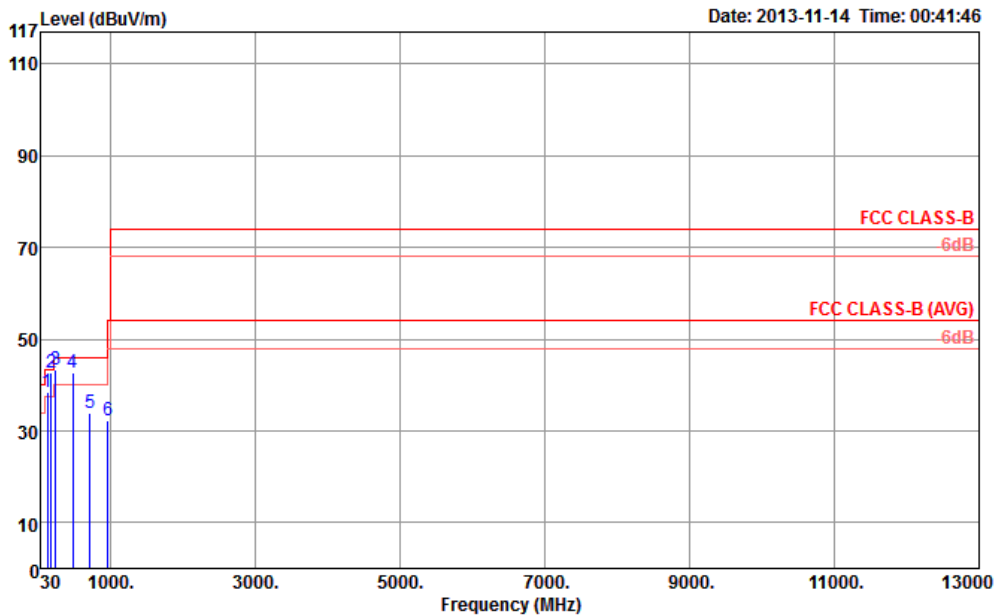

Site : 03CH01-SZ  
 Condition : FCC CLASS-B 3m LF\_ANT\_121103 HORIZONTAL  
 Project : (FC)3N1202  
 Mode : Mode 3

	Freq	Level	Over Limit	Limit Line	ReadAntenna Level	Antenna Factor	Cable Loss	Preamp Factor	A/Pos	T/Pos	Remark	
	MHz	dBuV/m	dB	dBuV/m	dBuV	dB/m	dB	dB	cm	deg		
1	!	131.85	38.41	-5.09	43.50	55.32	12.25	1.40	30.56	---	---	Peak
2	Q	180.35	42.83	-0.67	43.50	62.81	8.80	1.62	30.40	162	360	QP
3	!	236.61	43.29	-2.71	46.00	60.12	11.57	1.81	30.21	---	---	QP
4	P	480.08	42.66	-3.34	46.00	52.38	17.20	2.48	29.40	---	---	Peak
5		719.67	33.81	-12.19	46.00	39.86	20.00	2.99	29.04	---	---	Peak
6		960.23	32.28	-21.72	54.00	35.77	21.80	3.43	28.72	---	---	Peak



Test Mode :	Mode 3	Temperature :	24~25°C
Test Engineer :	Leo Liao	Relative Humidity :	48~49%
Test Distance :	3m	Polarization :	Vertical
Function Type :	WCDMA Band V Idle + Bluetooth Idle + WLAN Idle + USB Cable (Data Link with Notebook) + Earphone + GPS Rx + SIM1		

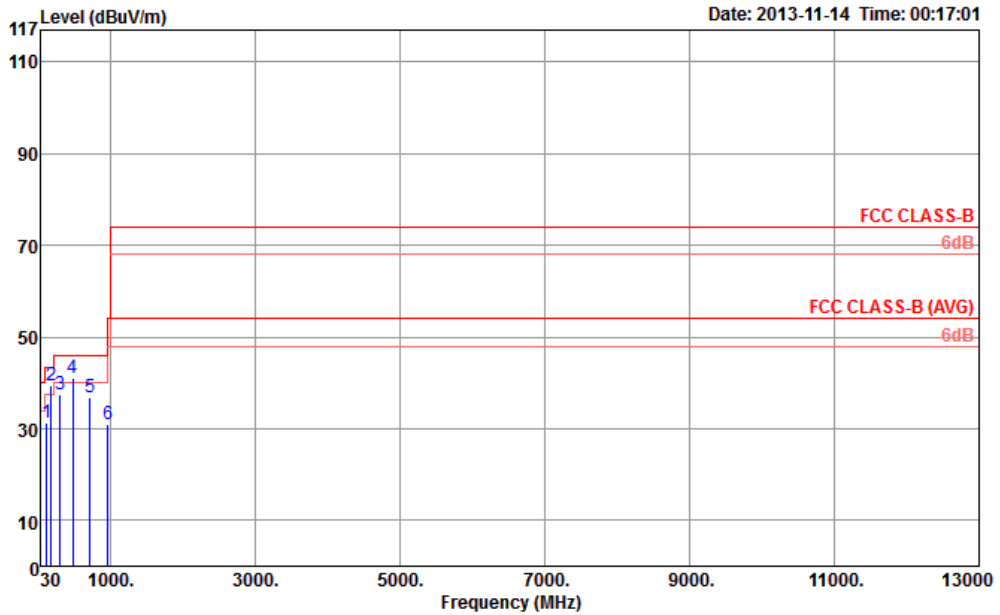

Site : 03CH01-SZ  
 Condition : FCC CLASS-B 3m LF\_ANT\_121103 VERTICAL  
 Project : (FC)3N1202  
 Mode : Mode 3

	Freq	Level	Over Limit	Limit Line	ReadAntenna Level	Antenna Factor	Cable Loss	Preamp Factor	A/Pos	T/Pos	Remark
	MHz	dBuV/m	dB	dBuV/m	dBuV	dB/m	dB	dB	cm	deg	
1	120.21	31.20	-12.30	43.50	48.25	12.20	1.35	30.60	---	---	Peak
2 P	180.35	39.40	-4.10	43.50	59.38	8.80	1.62	30.40	150	265	Peak
3	299.66	37.44	-8.56	46.00	52.42	13.00	2.02	30.00	---	---	Peak
4 !	480.08	41.03	-4.97	46.00	50.75	17.20	2.48	29.40	---	---	Peak
5	719.67	36.98	-9.02	46.00	43.03	20.00	2.99	29.04	---	---	Peak
6	960.23	30.83	-23.17	54.00	34.32	21.80	3.43	28.72	---	---	Peak



### 4. List of Measuring Equipment

Instrument	Manufacturer	Model No.	Serial No.	Characteristics	Calibration Date	Test Date	Due Date	Remark
AC LISN	ETS-LINDGREN	3816/2SH	00103912	0.1MHz~108MHz	Feb. 28, 2011	Nov. 14, 2013	Feb. 27, 2014	Conduction (CO01-SZ)
AC LISN (for auxiliary equipment)	ETS-LINDGREN	3816/2SH	00103892	0.1MHz~108MHz	Feb. 28, 2011	Nov. 14, 2013	Feb. 27, 2014	Conduction (CO01-SZ)
ESCIO TEST Receiver	R&S	1142.8007.03	100724	9kHz~3GHz	Mar. 08, 2011	Nov. 14, 2013	Mar. 07, 2014	Conduction (CO01-SZ)
AC Power Source	Chroma	61602	616020000891N/A	N/A	Nov. 20, 2012	Nov. 14, 2013	Nov. 19, 2013	Conduction (CO01-SZ)
Spectrum Analyzer	Agilent Technologies	N9038A	MY52260185	20Hz~26.5GHz	Apr. 04, 2013	Nov. 14, 2013	Apr. 03, 2014	Radiation (03CH01-SZ)
Double Ridge Horn Antenna	ETS Lindgren	3117	00119436	1GHz~18GHz	Oct. 26, 2013	Nov. 14, 2013	Oct. 25, 2014	Radiation (03CH01-SZ)
Bilog Antenna	SCHAFFNER	CBL6112B	2614	30MHz~2GHz	Dec. 26, 2012	Nov. 14, 2013	Dec. 25, 2013	Radiation (03CH01-SZ)
Amplifier	ADVANTEST	BB525C	E9007003	9kHz~3000MHz GAIN 30db	Mar. 28, 2013	Nov. 14, 2013	Mar. 27, 2014	Radiation (03CH01-SZ)
Amplifier	Yiai	AV3860B	04030	2GHz~26.5GHz	Mar. 28, 2013	Nov. 14, 2013	Mar. 27, 2014	Radiation (03CH01-SZ)
Turn Table	EM Electronics	EM 1000	N/A	0 ~ 360 degree	N/A	Nov. 14, 2013	N/A	Radiation (03CH01-SZ)
Antenna Mast	EM Electronics	EM 1000	N/A	1 m - 4 m	N/A	Nov. 14, 2013	N/A	Radiation (03CH01-SZ)

## 5. Uncertainty of Evaluation

### Uncertainty of Conducted Emission Measurement (150 kHz ~ 30 MHz)

Measuring Uncertainty for a Level of Confidence of 95% ( $U = 2Uc(y)$ )	2.26
---	------

### Uncertainty of Radiated Emission Measurement (30 MHz ~ 1000 MHz)

Measuring Uncertainty for a Level of Confidence of 95% ( $U = 2Uc(y)$ )	3.90
---	------