

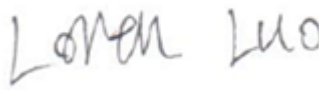

RF TEST REPORT

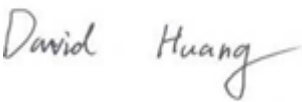

Report No.: 17070763-FCC-R5

Supersede Report No.: N/A

Applicant	BLU Products, Inc.	
Product Name	Mobile Phone	
Model No.	C5 LTE	
Serial No.	N/A	
Test Standard	FCC Part 22(H):2015, FCC Part 24(E):2015, FCC Part 27: 2015; ANSI/TIA-603-D: 2010	
Test Date	October 16 to November 06, 2017	
Issue Date	November 07, 2017	
Test Result	<input checked="" type="checkbox"/> Pass <input type="checkbox"/> Fail	
Equipment complied with the specification	<input checked="" type="checkbox"/>	
Equipment did not comply with the specification	<input type="checkbox"/>	
		
Loren Luo Test Engineer	David Huang Checked By	
This test report may be reproduced in full only Test result presented in this test report is applicable to the tested sample only		

Issued by:

SIEMIC (SHENZHEN-CHINA) LABORATORIES

Zone A, Floor 1, Building 2 Wan Ye Long Technology Park

South Side of Zhoushi Road, Bao' an District, Shenzhen, Guangdong China 518108

Phone: +86 0755 2601 4629801 Email: China@siemic.com.cn

Laboratories Introduction

SIEMIC, headquartered in the heart of Silicon Valley, with superior facilities in US and Asia, is one of the leading independent testing and certification facilities providing customers with one-stop shop services for Compliance Testing and Global Certifications.



In addition to testing and certification, SIEMIC provides initial design reviews and compliance management throughout a project. Our extensive experience with China, Asia Pacific, North America, European, and International compliance requirements, assures the fastest, most cost effective way to attain regulatory compliance for the global markets.

Accreditations for Conformity Assessment

Country/Region	Scope
USA	EMC, RF/Wireless, SAR, Telecom
Canada	EMC, RF/Wireless, SAR, Telecom
Taiwan	EMC, RF, Telecom, SAR, Safety
Hong Kong	RF/Wireless, SAR, Telecom
Australia	EMC, RF, Telecom, SAR, Safety
Korea	EMI, EMS, RF, SAR, Telecom, Safety
Japan	EMI, RF/Wireless, SAR, Telecom
Singapore	EMC, RF, SAR, Telecom
Europe	EMC, RF, SAR, Telecom, Safety

Test Report	17070763-FCC-R5
Page	3 of 80

This page has been left blank intentionally.

CONTENTS

1. REPORT REVISION HISTORY	5
2. CUSTOMER INFORMATION	5
3. TEST SITE INFORMATION	5
4. EQUIPMENT UNDER TEST (EUT) INFORMATION	6
5. TEST SUMMARY	8
6. MEASUREMENTS, EXAMINATION AND DERIVED RESULTS	9
6.1 RF EXPOSURE (SAR)	9
6.2 RF OUTPUT POWER	10
6.3 PEAK-AVERAGE RATIO	25
6.4 OCCUPIED BANDWIDTH	28
6.5 SPURIOUS EMISSIONS AT ANTENNA TERMINALS	39
6.6 SPURIOUS RADIATED EMISSIONS	42
6.7 BAND EDGE	46
6.8 BAND EDGE 27.53(M)	52
6.9 FREQUENCY STABILITY	58
ANNEX A. TEST INSTRUMENT	61
ANNEX B. EUT AND TEST SETUP PHOTOGRAPHS	63
ANNEX C. TEST SETUP AND SUPPORTING EQUIPMENT	76
ANNEX C.II. EUT OPERATING CONKITIONS	78
ANNEX D. USER MANUAL / BLOCK DIAGRAM / SCHEMATICS / PARTLIST	79
ANNEX E. DECLARATION OF SIMILARITY.....	80

1. Report Revision History

Report No.	Report Version	Description	Issue Date
17070763-FCC-R5	NONE	Original	November 07, 2017

2. Customer information

Applicant Name	BLU Products, Inc.
Applicant Add	10814 NW 33rd St#100 Doral, FL33172, USA
Manufacturer	BLU Products, Inc.
Manufacturer Add	10814 NW 33rd St#100 Doral, FL33172, USA

3. Test site information

Test Lab A:

Lab performing tests	SIEMIC (Shenzhen-China) LABORATORIES
Lab Address	Zone A, Floor 1, Building 2 Wan Ye Long Technology Park South Side of Zhoushi Road, Bao' an District, Shenzhen, Guangdong China 518108
FCC Test Site No.	535293
IC Test Site No.	4842E-1
Test Software	Radiated Emission Program-To Shenzhen v2.0

Test Lab B:

Lab performing tests	SIEMIC (Nanjing-China) Laboratories
Lab Address	2-1 Longcang Avenue Yuhua Economic and Technology Development Park, Nanjing, China
FCC Test Site No.	694825
IC Test Site No.	4842B-1
Test Software	EZ_EMG(ver.lcp-03A1)

Note: We just perform Radiated Spurious Emission above 18GHz in the test Lab. B.

4. Equipment under Test (EUT) Information

Description of EUT:	Mobile Phone
Main Model:	C5 LTE
Serial Model:	N/A
Date EUT received:	October 16, 2017
Test Date(s):	October 16 to November 06, 2017
Equipment Category :	PCE
Antenna Gain:	<p>GSM850: 0.5dBi PCS1900: 0.8dBi UMTS-FDD Band V: 0.5dBi UMTS-FDD Band II: 0.8dBi LTE Band 5: 0.8dBi LTE Band 7: 1.2dBi Bluetooth/BLE: 0.5dBi WIFI: 0.5dBi GPS: 0.5dBi</p>
Type of Modulation:	<p>GSM / GPRS: GMSK EGPRS: GMSK,8PSK UMTS-FDD: QPSK LTE Band: QPSK, 16QAM 802.11b/g/n: DSSS, OFDM Bluetooth: GFSK, π /4DQPSK, 8DPSK BLE: GFSK GPS:BPSK FM: FM</p>
RF Operating Frequency (ies):	<p>GSM850 TX: 824.2 ~ 848.8 MHz; RX: 869.2 ~ 893.8 MHz PCS1900 TX: 1850.2 ~ 1909.8 MHz; RX: 1930.2 ~ 1989.8 MHz UMTS-FDD Band V TX: 826.4 ~ 846.6 MHz; RX: 871.4 ~ 891.6 MHz UMTS-FDD Band II TX:1852.4 ~ 1907.6 MHz; RX: 1932.4 ~ 1987.6 MHz LTE Band 5 TX: 826.5 ~ 846.5 MHz; RX : 871.5 ~ 891.5 MHz</p>

LTE Band 7 TX: 2502.5 ~ 2567.5 MHz; RX : 2622.5 ~ 2687.5 MHz

WIFI: 802.11b/g/n(20M): 2412-2462 MHz

WIFI: 802.11n(40M): 2422-2452 MHz

Bluetooth& BLE: 2402-2480 MHz

GPS: 1575.42 MHz

FM: 87.5 MHz - 108 MHz(RX)

Maximum Conducted
AV Power to Antenna:

LTE Band 5: 23.19 dBm

LTE Band 7: 22.62 dBm

ERP/EIRP:

LTE Band 5: 21.84 dBm / EIRP

LTE Band 7: 23.75 dBm / EIRP

Port:

USB Port, Earphone Port

Input Power:

Adapter:

Model: US-WW-1002

Input: AC100-240V~50/60Hz, 0.2A

Output: DC 5.0V,1000mA

Battery:

Model: C775840200L

Spec: 3.8V, 2000mAh, 7.60Wh

Trade Name :

BLU

GPRS/ EGPRS Multi-slot class

8/10/11/12

FCC ID:

YHLBLUC5LTE

5. Test Summary

The product was tested in accordance with the following specifications.

All testing has been performed according to below product classification:

FCC Rules	Description of Test	Result
§ 1.1307; § 2.1093	RF Exposure (SAR)	Compliance
§2.1046; § 22.913(a); § 24.232(c); § 27.50(c.10); § 27.50(d.4)	RF Output Power	Compliance
§ 24.232 (d); § 27.50(d)	Peak-Average Ratio	Compliance
§ 2.1047	Modulation Characteristics	N/A
§ 2.1049; § 22.905; § 22.917; § 24.238; § 27.53(a.5)	99% & -26 dB Occupied Bandwidth	Compliance
§ 2.1051; § 22.917(a); § 24.238(a); § 27.53(h)	Spurious Emissions at Antenna Terminal	Compliance
§ 2.1053; § 22.917(a); § 24.238(a); § 27.53(h)	Field Strength of Spurious Radiation	Compliance
§ 22.917(a); § 24.238(a);	Out of band emission, Band Edge	Compliance
§ 27.53(m)	Band Edge 27.53(m)	Compliance
§ 2.1055; § 22.355; § 24.235; § 27.5(h); § 27.54	Frequency stability vs. temperature Frequency stability vs. voltage	Compliance

Note: Testing was performed by configuring EUT to maximum output power status, the declared output power class for different

Measurement Uncertainty

Emissions		
Test Item	Description	Uncertainty
Band Edge and Radiated Spurious Emissions	Confidence level of approximately 95% (in the case where distributions are normal), with a coverage factor of 2 (for EUTs < 0.5m X 0.5m X 0.5m)	+5.6dB/-4.5dB
-	-	-

6. MEASUREMENTS, EXAMINATION AND DERIVED RESULTS

6.1 RF Exposure (SAR)

Test Result: Pass

The EUT is a portable device, thus requires SAR evaluation;

Please refer to RF Exposure Evaluation Report: 17070763-FCC-H.

6.2 RF Output Power

Temperature	26 °C
Relative Humidity	56%
Atmospheric Pressure	1022mbar
Test date :	October 26, 2017
Tested By :	Loren Luo

Requirement(s):

Spec	Item	Requirement	Applicable
§22.913 (a)	a)	ERP:38.45dBm	<input checked="" type="checkbox"/>
§24.232 (c)	b)	EIRP:33dBm	<input checked="" type="checkbox"/>
§27.50 (c)	c)	EIRP: 30dBm	<input checked="" type="checkbox"/>

Test Setup

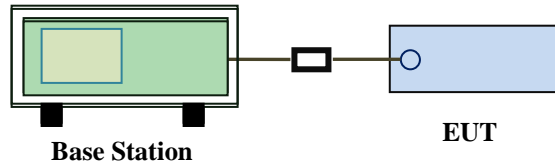

Test Procedure

For Conducted Power:

- The transmitter output port was connected to base station.
- Set EUT at maximum power through base station.
- Select lowest, middle, and highest channels for each band and different test mode.

For ERP/EIRP:

- The transmitter was placed on a wooden turntable, and it was transmitting into a non-radiating load which was also placed on the turntable.
- The measurement antenna was placed at a distance of 3 meters from the EUT. During the tests, the antenna height and polarization as well as EUT azimuth were varied in order to identify the maximum level of emissions from the EUT. The test was performed by placing the EUT on 3-orthogonal axis.
- The frequency range up to tenth harmonic of the fundamental frequency was investigated.

	<ul style="list-style-type: none"> - Remove the EUT and replace it with substitution antenna. A signal generator was connected to the substitution antenna by a non-radiating cable. The absolute levels of the spurious emissions were measured by the substitution. - Spurious emissions in dB = 10 log (TX power in Watts/0.001) – the absolute level - Spurious attenuation limit in dB = 43 + 10 Log10 (power out in Watts).
Remark	
Result	<input checked="" type="checkbox"/> Pass <input type="checkbox"/> Fail

Test Data Yes N/A
 Test Plot Yes (See below) N/A

Conducted Power

LTE Band 5:

BW (MHz)	Ch	Freq. (MHz)	Mode	UL RB Allocation	UL RB Offset	MPR	Average power (dBm)	Tune up Power tolerant
10MHz	20450	829	QPSK	1	0	0	23.11	23.1±1
				1	12	0	23.18	23.1±1
				1	24	0	23.07	23.1±1
				12	0	1	23.16	23.1±1
				12	6	1	23.05	23.1±1
				12	11	1	23.05	23.1±1
				25	0	1	23.02	23.1±1
			16QAM	1	0	1	23.09	23.1±1
				1	12	1	23.02	23.1±1
				1	24	1	23.19	23.1±1
				12	0	2	23.11	23.1±1
				12	6	2	23.01	23.1±1
				12	11	2	23.16	23.1±1
				25	0	2	23.08	23.1±1
	20525	836.5	QPSK	1	0	0	23.09	22.6±1
				1	12	0	23.08	22.6±1
				1	24	0	23.07	22.6±1
				12	0	1	22.09	22.6±1
				12	6	1	22.13	22.6±1
				12	11	1	22.12	22.6±1
				25	0	1	22.08	22.6±1
			16QAM	1	0	1	22.08	21.5±1
				1	12	1	22.01	21.5±1
				1	24	1	22	21.5±1
				12	0	2	20.98	21.5±1
				12	6	2	20.99	21.5±1
				12	11	2	21.04	21.5±1
				25	0	2	21.1	21.5±1
20600	844	QPSK	1	0	0	22.95	22.5±1	
			1	12	0	22.97	22.5±1	
			1	24	0	22.86	22.5±1	
			12	0	1	22.01	22.5±1	
			12	6	1	21.99	22.5±1	

			16QAM	12	11	1	21.99	22.5±1
				25	0	1	22.01	22.5±1
				1	0	1	22.6	21.8±1
				1	12	1	22.64	21.8±1
				1	24	1	22.62	21.8±1
				12	0	2	20.97	21.8±1
				12	6	2	21.04	21.8±1
				12	11	2	20.93	21.8±1
				25	0	2	21.04	21.8±1

BW (MHz)	Ch	Freq. (MHz)	Mode	UL RB Allocation	UL RB Offset	MPR	Average power (dBm)	Tune up Power tolerant
5MHz	20425	826.5	QPSK	1	0	0	23.05	23.1±1
				1	24	0	22.98	23.1±1
				1	49	0	23.14	23.1±1
				25	0	1	23.11	23.1±1
				25	12	1	23.04	23.1±1
				25	24	1	23.12	23.1±1
				50	0	1	23.07	23.1±1
			16QAM	1	0	1	23	23±1
				1	24	1	23.04	23±1
				1	49	1	23.08	23±1
				25	0	2	23.03	23±1
				25	12	2	23.04	23±1
				25	24	2	22.95	23±1
				50	0	2	23.1	23±1
	20525	836.5	QPSK	1	0	0	23	22.5±1
				1	24	0	22.95	22.5±1
				1	49	0	22.91	22.5±1
				25	0	1	22.1	22.5±1
				25	12	1	22.16	22.5±1
				25	24	1	22.1	22.5±1
				50	0	1	22.04	22.5±1
			16QAM	1	0	1	22.1	21.5±1
				1	24	1	22.14	21.5±1
				1	49	1	22.14	21.5±1
				25	0	2	20.85	21.5±1
				25	12	2	20.81	21.5±1
				25	24	2	20.76	21.5±1
				50	0	2	21.09	21.5±1
	20625	846.5	QPSK	1	0	0	23.02	22.5±1
				1	24	0	23.11	22.5±1
1				49	0	23.08	22.5±1	
25				0	1	22.06	22.5±1	
25				12	1	22.04	22.5±1	

				25	24	1	22.01	22.5±1
				50	0	1	21.98	22.5±1
			16QAM	1	0	1	21.95	21.5±1
				1	24	1	22.05	21.5±1
				1	49	1	21.89	21.5±1
				25	0	2	21.05	21.5±1
				25	12	2	21.08	21.5±1
				25	24	2	21.03	21.5±1
				50	0	2	21.03	21.5±1

BW (MHz)	Ch	Freq. (MHz)	Mode	UL RB Allocation	UL RB Offset	MPR	Average power (dBm)	Tune up Power tolerant
3MHz	20415	825.5	QPSK	1	0	0	22.86	22.9±1
				1	7	0	22.94	22.9±1
				1	14	0	22.89	22.9±1
				8	0	1	22.91	22.9±1
				8	4	1	22.88	22.9±1
				8	7	1	22.9	22.9±1
				15	0	1	22.9	22.9±1
			16QAM	1	0	1	23.05	23±1
				1	7	1	23.06	23±1
				1	14	1	23.04	23±1
				8	0	2	23.01	23±1
				8	4	2	22.95	23±1
				8	7	2	23.14	23±1
				15	0	2	23.08	23±1
				20525	836.5	QPSK	1	0
	1	7	0				23.02	22.6±1
	1	14	0				23.1	22.6±1
	8	0	1				22.01	22.6±1
	8	4	1				22.04	22.6±1
	8	7	1				22.05	22.6±1
	15	0	1				22.05	22.6±1
	16QAM	1	0			1	21.89	21.3±1
		1	7			1	21.81	21.3±1
		1	14			1	21.81	21.3±1
		8	0			2	20.78	21.3±1
		8	4			2	20.88	21.3±1
		8	7			2	20.85	21.3±1
		15	0			2	21.03	21.3±1
		20635	847.5			QPSK	1	0
	1			7	0		22.92	22.4±1
1	14			0	23.06		22.4±1	
8	0			1	21.91		22.4±1	
8	4			1	21.86		22.4±1	
8	7			1	21.82		22.4±1	
15	0			1	21.96		22.4±1	
16QAM	1			0	1	21.91	21.4±1	
	1			7	1	21.85	21.4±1	
	1			14	1	21.98	21.4±1	
	8			0	2	20.78	21.4±1	
	8			4	2	20.76	21.4±1	
	8			7	2	20.78	21.4±1	
	15			0	2	20.99	21.4±1	

BW (MHz)	Ch	Freq. (MHz)	Mode	UL RB Allocation	UL RB Offset	MPR	Average power (dBm)	Tune up Power tolerant
1.4MHz	20407	824.7	QPSK	1	0	0	23.02	23±1
				1	2	0	22.94	23±1
				1	5	0	23.11	23±1
				3	0	0	23.05	23±1
				3	1	0	23.08	23±1
				3	2	0	22.99	23±1
				6	0	1	23.03	23±1
			16QAM	1	0	1	23.01	23±1
				1	2	1	23.03	23±1
				1	5	1	23.1	23±1
				3	0	1	23.08	23±1
				3	1	1	22.93	23±1
				3	2	1	23.1	23±1
				6	0	2	23.11	23±1
	20525	836.5	QPSK	1	0	0	23.01	22.5±1
				1	2	0	23.1	22.5±1
				1	5	0	23.08	22.5±1
				3	0	0	23.05	22.5±1
				3	1	0	22.99	22.5±1
				3	2	0	23.02	22.5±1
				6	0	1	21.96	22.5±1
			16QAM	1	0	1	21.98	21.5±1
				1	2	1	22.07	21.5±1
				1	5	1	21.95	21.5±1
				3	0	1	21	21.5±1
				3	1	1	20.99	21.5±1
				3	2	1	20.94	21.5±1
				6	0	2	20.87	21.5±1
	20643	848.3	QPSK	1	0	0	22.88	22.5±1
				1	2	0	22.87	22.5±1
1				5	0	22.89	22.5±1	
3				0	0	23.02	22.5±1	
3				1	0	22.96	22.5±1	
3				2	0	22.96	22.5±1	
6				0	1	21.94	22.5±1	
16QAM			1	0	1	21.53	21.3±1	
			1	2	1	21.55	21.3±1	
			1	5	1	21.54	21.3±1	
			3	0	1	20.98	21.3±1	
			3	1	1	20.94	21.3±1	
			3	2	1	20.99	21.3±1	
			6	0	2	20.86	21.3±1	

LTE Band 7:

BW (MHz)	Ch	Freq. (MHz)	Mode	UL RB Allocation	UL RB Offset	MPR	Average power (dBm)	Tune up Power tolerant
20MHz	20850	2510	QPSK	1	0	0	22.52	22.6±1
				1	49	0	22.62	22.6±1
				1	99	0	22.55	22.6±1
				50	0	1	22.52	22.6±1
				50	24	1	22.59	22.6±1
				50	49	1	22.61	22.6±1
				100	0	1	22.56	22.6±1
			16QAM	1	0	1	22.13	22.1±1
				1	49	1	22.15	22.1±1
				1	99	1	22.14	22.1±1
				50	0	2	22.04	22.1±1
				50	24	2	22.08	22.1±1
				50	49	2	22.19	22.1±1
				100	0	2	22.12	22.1±1
	21100	2535	QPSK	1	0	0	22.13	21.6±1
				1	49	0	22.15	21.6±1
				1	99	0	22.11	21.6±1
				50	0	1	21.18	21.6±1
				50	24	1	21.23	21.6±1
				50	49	1	21.08	21.6±1
				100	0	1	21.21	21.6±1
			16QAM	1	0	1	21.41	21.3±1
				1	49	1	21.38	21.3±1
				1	99	1	21.46	21.3±1
				50	0	2	20.59	21.3±1
				50	24	2	20.52	21.3±1
				50	49	2	20.63	21.3±1
				100	0	2	20.39	21.3±1
	21350	2560	QPSK	1	0	0	21.75	21.4±1
				1	49	0	21.76	21.4±1
1				99	0	21.81	21.4±1	
50				0	1	21.08	21.4±1	
50				24	1	21.03	21.4±1	
50				49	1	21.14	21.4±1	
100				0	1	21.15	21.4±1	
16QAM			1	0	1	21.22	21.3±1	
			1	49	1	21.24	21.3±1	
			1	99	1	21.23	21.3±1	
			50	0	2	20.39	21.3±1	
			50	24	2	20.39	21.3±1	
			50	49	2	20.34	21.3±1	
			100	0	2	20.38	21.3±1	

BW (MHz)	Ch	Freq. (MHz)	Mode	UL RB Allocation	UL RB Offset	MPR	Average power (dBm)	Tune up Power tolerant
15MHz	20825	1717.5	QPSK	1	0	0	22.08	22.1±1
				1	37	0	22.01	22.1±1
				1	74	0	22.16	22.1±1
				36	0	1	22.01	22.1±1
				36	16	1	22.16	22.1±1
				36	35	1	22.14	22.1±1
				75	0	1	22.1	22.1±1
			16QAM	1	0	1	22.52	22.5±1
				1	37	1	22.53	22.5±1
				1	74	1	22.45	22.5±1
				36	0	2	22.58	22.5±1
				36	16	2	22.45	22.5±1
				36	35	2	22.55	22.5±1
				75	0	2	22.58	22.5±1
	21100	1732.5	QPSK	1	0	0	22.52	22±1
				1	37	0	22.51	22±1
				1	74	0	22.46	22±1
				36	0	1	21.45	22±1
				36	16	1	21.39	22±1
				36	35	1	21.47	22±1
				75	0	1	21.39	22±1
			16QAM	1	0	1	21.63	21.3±1
				1	37	1	21.56	21.3±1
				1	74	1	21.37	21.3±1
				36	0	2	20.38	21.3±1
				36	16	2	20.44	21.3±1
				36	35	2	20.42	21.3±1
				75	0	2	20.32	21.3±1
	21375	1747.5	QPSK	1	0	0	21.49	21.3±1
				1	37	0	21.48	21.3±1
1				74	0	21.47	21.3±1	
36				0	1	21.07	21.3±1	
36				16	1	21.16	21.3±1	
36				35	1	20.99	21.3±1	
75				0	1	21.28	21.3±1	
16QAM			1	0	1	21.08	21.3±1	
			1	37	1	20.99	21.3±1	
			1	74	1	21.37	21.3±1	
			36	0	2	20.51	21.3±1	
			36	16	2	20.39	21.3±1	
			36	35	2	20.41	21.3±1	
			75	0	2	20.36	21.3±1	

BW (MHz)	Ch	Freq. (MHz)	Mode	UL RB Allocation	UL RB Offset	MPR	Average power (dBm)	Tune up Power tolerant
10MHz	20800	2502	QPSK	1	0	0	22.47	22.5±1
				1	24	0	22.48	22.5±1
				1	49	0	22.4	22.5±1
				25	0	1	22.55	22.5±1
				25	12	1	22.41	22.5±1
				25	24	1	22.54	22.5±1
				50	0	1	22.47	22.5±1
			16QAM	1	0	1	22.18	22.2±1
				1	24	1	22.26	22.2±1
				1	49	1	22.22	22.2±1
				25	0	2	22.12	22.2±1
				25	12	2	22.22	22.2±1
				25	24	2	22.24	22.2±1
				50	0	2	22.2	22.2±1
	21100	2535	QPSK	1	0	0	22.18	21.6±1
				1	24	0	22.14	21.6±1
				1	49	0	22.18	21.6±1
				25	0	1	21.08	21.6±1
				25	12	1	21.05	21.6±1
				25	24	1	21.01	21.6±1
				50	0	1	21.25	21.6±1
			16QAM	1	0	1	21.06	21.3±1
				1	24	1	21.05	21.3±1
				1	49	1	21.07	21.3±1
				25	0	2	20.51	21.3±1
				25	12	2	20.6	21.3±1
				25	24	2	20.42	21.3±1
				50	0	2	20.34	21.3±1
	21400	2565	QPSK	1	0	0	21.81	21.6±1
				1	24	0	21.89	21.6±1
1				49	0	21.77	21.6±1	
25				0	1	21.31	21.6±1	
25				12	1	21.37	21.6±1	
25				24	1	21.33	21.6±1	
50				0	1	21.29	21.6±1	
16QAM			1	0	1	21.5	21.3±1	
			1	24	1	21.52	21.3±1	
			1	49	1	21.55	21.3±1	
			25	0	2	20.52	21.3±1	
			25	12	2	20.42	21.3±1	
			25	24	2	20.43	21.3±1	
			50	0	2	20.36	21.3±1	

BW (MHz)	Ch	Freq. (MHz)	Mode	UL RB Allocation	UL RB Offset	MPR	Average power (dBm)	Tune up Power tolerant
5MHz	19975	1712.5	QPSK	1	0	0	22.31	22.3±1
				1	12	0	22.29	22.3±1
				1	24	0	22.33	22.3±1
				12	0	1	22.28	22.3±1
				12	6	1	22.27	22.3±1
				12	11	1	22.3	22.3±1
				25	0	1	22.29	22.3±1
			16QAM	1	0	1	22.02	22±1
				1	12	1	21.93	22±1
				1	24	1	22.01	22±1
				12	0	2	22.03	22±1
				12	6	2	22.04	22±1
				12	11	2	21.92	22±1
				25	0	2	22.11	22±1
	20175	1732.5	QPSK	1	0	0	22.02	21.6±1
				1	12	0	22.06	21.6±1
				1	24	0	21.96	21.6±1
				12	0	1	21.11	21.6±1
				12	6	1	21.15	21.6±1
				12	11	1	21.06	21.6±1
				25	0	1	21.06	21.6±1
			16QAM	1	0	1	21.07	21.3±1
				1	12	1	21.15	21.3±1
				1	24	1	21.01	21.3±1
				12	0	2	20.42	21.3±1
				12	6	2	20.43	21.3±1
				12	11	2	20.46	21.3±1
				25	0	2	20.45	21.3±1
20375	1752.5	QPSK	1	0	0	22.42	21.9±1	
			1	12	0	22.51	21.9±1	
			1	24	0	22.43	21.9±1	
			12	0	1	21.43	21.9±1	
			12	6	1	21.4	21.9±1	
			12	11	1	21.38	21.9±1	
			25	0	1	21.38	21.9±1	
		16QAM	1	0	1	21.35	21.3±1	
			1	12	1	21.36	21.3±1	
			1	24	1	21.29	21.3±1	
			12	0	2	20.3	21.3±1	
			12	6	2	20.32	21.3±1	
			12	11	2	20.35	21.3±1	
			25	0	2	20.41	21.3±1	

ERP & EIRP

EIRP for LTE Band 5 (Part 22)

Frequency (MHz)	BW (MHz)	Modulation	RB Size/Offset	Substituted level (dBm)	Antenna Polarization	Antenna Gain correction (dBi)	Cable Loss (dB)	Absolute Level (dBm)	Limit (dBm)
824.7	1.4	QPSK	1/5	15.4	V	6.8	0.44	21.76	34.77
836.5	1.4	QPSK	1/5	15.37	V	6.8	0.44	21.73	34.77
848.3	1.4	QPSK	1/5	15.08	V	6.9	0.44	21.54	34.77
824.7	1.4	QPSK	1/5	15.17	H	6.8	0.44	21.53	34.77
836.5	1.4	QPSK	1/5	15.09	H	6.8	0.44	21.45	34.77
848.3	1.4	QPSK	1/5	14.85	H	6.9	0.44	21.31	34.77
824.7	1.4	16-QAM	1/5	15.39	V	6.8	0.44	21.75	34.77
836.5	1.4	16-QAM	1/5	14.24	V	6.8	0.44	20.6	34.77
848.3	1.4	16-QAM	1/5	13.73	V	6.9	0.44	20.19	34.77
824.7	1.4	16-QAM	1/5	15.21	H	6.8	0.44	21.57	34.77
836.5	1.4	16-QAM	1/5	13.66	H	6.8	0.44	20.02	34.77
848.3	1.4	16-QAM	1/5	13.6	H	6.9	0.44	20.06	34.77
825.5	3	QPSK	1/14	15.18	V	6.8	0.44	21.54	34.77
836.5	3	QPSK	1/0	15.34	V	6.8	0.44	21.7	34.77
847.5	3	QPSK	1/14	15.25	V	6.9	0.44	21.71	34.77
825.5	3	QPSK	1/14	14.85	H	6.8	0.44	21.21	34.77
836.5	3	QPSK	1/0	14.48	H	6.8	0.44	20.84	34.77
847.5	3	QPSK	1/14	13.69	H	6.9	0.44	20.15	34.77
825.5	3	16-QAM	1/14	15.33	V	6.8	0.44	21.69	34.77
836.5	3	16-QAM	1/0	14.18	V	6.8	0.44	20.54	34.77
847.5	3	16-QAM	1/14	14.17	V	6.9	0.44	20.63	34.77
825.5	3	16-QAM	1/14	15.2	H	6.8	0.44	21.56	34.77
836.5	3	16-QAM	1/0	13.8	H	6.8	0.44	20.16	34.77
847.5	3	16-QAM	1/14	13.78	H	6.9	0.44	20.24	34.77
826.5	5	QPSK	1/24	15.43	V	6.8	0.44	21.79	34.77
836.5	5	QPSK	1/24	15.2	V	6.8	0.44	21.56	34.77
846.5	5	QPSK	1/24	15.39	V	6.8	0.44	21.75	34.77
826.5	5	QPSK	1/24	15.29	H	6.8	0.44	21.65	34.77
836.5	5	QPSK	1/24	15.16	H	6.8	0.44	21.52	34.77
846.5	5	QPSK	1/24	14.98	H	6.8	0.44	21.34	34.77

826.5	5	16-QAM	1/24	15.37	V	6.8	0.44	21.73	34.77
836.5	5	16-QAM	1/24	14.43	V	6.8	0.44	20.79	34.77
846.5	5	16-QAM	1/24	14.18	V	6.8	0.44	20.54	34.77
826.5	5	16-QAM	1/24	14.87	H	6.8	0.44	21.23	34.77
836.5	5	16-QAM	1/24	13.95	H	6.8	0.44	20.31	34.77
846.5	5	16-QAM	1/24	13.82	H	6.8	0.44	20.18	34.77
829	10	QPSK	1/49	15.36	V	6.8	0.44	21.72	34.77
836.5	10	QPSK	1/49	15.36	V	6.8	0.44	21.72	34.77
844	10	QPSK	1/49	15.15	V	6.8	0.44	21.51	34.77
829	10	QPSK	1/49	14.85	H	6.8	0.44	21.21	34.77
836.5	10	QPSK	1/49	14.96	H	6.8	0.44	21.32	34.77
844	10	QPSK	1/49	14.59	H	6.8	0.44	20.95	34.77
829	10	16-QAM	1/49	15.48	V	6.8	0.44	21.84	34.77
836.5	10	16-QAM	1/49	14.29	V	6.8	0.44	20.65	34.77
844	10	16-QAM	1/49	14.91	V	6.8	0.44	21.27	34.77
829	10	16-QAM	1/49	14.87	H	6.8	0.44	21.23	34.77
836.5	10	16-QAM	1/49	13.66	H	6.8	0.44	20.02	34.77
844	10	16-QAM	1/49	14.56	H	6.8	0.44	20.92	34.77

ERP for LTE Band 7 (Part 27)

Frequency (MHz)	BW (MHz)	Modulation	RB Size/Offset	Substituted level (dBm)	Antenna Polarization	Antenna Gain correction (dBi)	Cable Loss (dB)	Absolute Level (dBm)	Limit (dBm)
2502.5	5	QPSK	1/0	15.41	V	8.93	0.83	23.51	30
2535	5	QPSK	1/0	15.12	V	8.93	0.83	23.22	30
2567.5	5	QPSK	1/24	15.53	V	8.93	0.83	23.63	30
2502.5	5	QPSK	1/0	14.11	H	8.93	0.83	22.21	30
2535	5	QPSK	1/0	14.25	H	8.93	0.83	22.35	30
2567.5	5	QPSK	1/24	13.18	H	8.93	0.83	21.28	30
2502.5	5	16-QAM	1/0	15.12	V	8.93	0.83	23.22	30
2535	5	16-QAM	1/0	14.17	V	8.93	0.83	22.27	30
2567.5	5	16-QAM	1/24	14.39	V	8.93	0.83	22.49	30
2502.5	5	16-QAM	1/0	14.46	H	8.93	0.83	22.56	30
2535	5	16-QAM	1/0	13.52	H	8.93	0.83	21.62	30
2567.5	5	16-QAM	1/24	13	H	8.93	0.83	21.1	30
2505	10	QPSK	1/0	15.57	V	8.93	0.83	23.67	30
2535	10	QPSK	1/49	15.28	V	8.93	0.83	23.38	30
2565	10	QPSK	1/0	14.91	V	8.93	0.83	23.01	30
2505	10	QPSK	1/0	14.15	H	8.93	0.83	22.25	30
2535	10	QPSK	1/49	14.29	H	8.93	0.83	22.39	30
2565	10	QPSK	1/0	13.18	H	8.93	0.83	21.28	30
2505	10	16-QAM	1/0	15.28	V	8.93	0.83	23.38	30
2535	10	16-QAM	1/49	14.17	V	8.93	0.83	22.27	30
2565	10	16-QAM	1/0	14.6	V	8.93	0.83	22.7	30
2505	10	16-QAM	1/0	14.54	H	8.93	0.83	22.64	30
2535	10	16-QAM	1/49	13.48	H	8.93	0.83	21.58	30
2565	10	16-QAM	1/0	13.75	H	8.93	0.83	21.85	30
2507.5	15	QPSK	1/0	15.18	V	8.93	0.83	23.28	30
2535	15	QPSK	1/74	15.56	V	8.93	0.83	23.66	30
2562.5	15	QPSK	1/0	14.59	V	8.93	0.83	22.69	30
2507.5	15	QPSK	1/0	14.46	H	8.93	0.83	22.56	30
2535	15	QPSK	1/74	14.74	H	8.93	0.83	22.84	30
2562.5	15	QPSK	1/0	13.88	H	8.93	0.83	21.98	30

2507.5	15	16-QAM	1/0	15.62	V	8.93	0.83	23.72	30
2535	15	16-QAM	1/74	14.47	V	8.93	0.83	22.57	30
2562.5	15	16-QAM	1/0	14.18	V	8.93	0.83	22.28	30
2507.5	15	16-QAM	1/0	14.85	H	8.93	0.83	22.95	30
2535	15	16-QAM	1/74	13.42	H	8.93	0.83	21.52	30
2562.5	15	16-QAM	1/0	13.14	H	8.93	0.83	21.24	30
2510	20	QPSK	1/99	15.65	V	8.93	0.83	23.75	30
2535	20	QPSK	1/99	15.22	V	8.93	0.83	23.32	30
2560	20	QPSK	1/0	14.85	V	8.93	0.83	22.95	30
2510	20	QPSK	1/99	14.74	H	8.93	0.83	22.84	30
2535	20	QPSK	1/99	15.44	H	8.93	0.83	23.54	30
2560	20	QPSK	1/0	13.89	H	8.93	0.83	21.99	30
2510	20	16-QAM	1/99	15.24	V	8.93	0.83	23.34	30
2535	20	16-QAM	1/99	14.56	V	8.93	0.83	22.66	30
2560	20	16-QAM	1/0	14.32	V	8.93	0.83	22.42	30
2510	20	16-QAM	1/99	14.44	H	8.93	0.83	22.54	30
2535	20	16-QAM	1/99	13.76	H	8.93	0.83	21.86	30
2560	20	16-QAM	1/0	13.53	H	8.93	0.83	21.63	30

6.3 Peak-Average Ratio

Temperature	25 °C
Relative Humidity	57%
Atmospheric Pressure	1024mbar
Test date :	October 24, 2017
Tested By :	Loren Luo

Requirement(s):

Spec	Item	Requirement	Applicable
§24.232(d) § 27.50(d)	a)	The peak-to-average ratio (PAR) of the transmission may not exceed 13 dB.	<input checked="" type="checkbox"/>

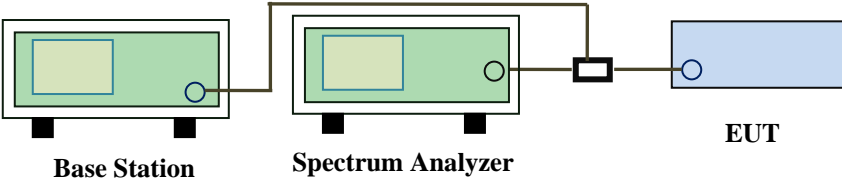
Test Setup	 <p>The diagram shows a Base Station (green box) connected to a Spectrum Analyzer (green box) via a cable. The Spectrum Analyzer is then connected to an EUT (blue box) via another cable. A small black box is also connected to the line between the Spectrum Analyzer and the EUT.</p>
------------	--

Test Procedure	<p>According with KDB 971168 v02r02</p> <p>5.7.2 Alternate procedure for PAPR</p> <p>5.1.2 Peak power measurements with a peak power meter</p> <p>The total peak output power may be measured using a broadband peak RF power meter. The power meter must have a video bandwidth that is greater than or equal to the emission bandwidth and utilize a fast-responding diode detector.</p> <p>5.2.3 Average power measurement with average power meter</p> <p>As an alternative to the use of a spectrum/signal analyzer or EMI receiver to perform a measurement of the total in-band average output power, a wideband RF average power meter with a thermocouple detector or equivalent can be used under certain conditions</p> <p>If the EUT can be configured to transmit continuously (i.e., the burst duty cycle $\geq 98\%$) and at all times the EUT is transmitting at its maximum output</p>
----------------	--

	<p>power level, then a conventional wide-band RF power meter can be used. If the EUT cannot be configured to transmit continuously (i.e., the burst duty cycle < 98%), then there are two options for the use of an average power meter. First, a gated average power meter can be used to perform the measurement if the gating parameters can be adjusted such that the power is measured only over active transmission bursts at maximum output power levels. A conventional average power meter can also be used if the measured burst duty cycle is constant (i.e., duty cycle variations are less than ± 2 percent) by performing the measurement over the on/off burst cycles and then correcting (increasing) the measured level by a factor equal to $10\log(1/\text{duty cycle})$</p>
Remark	
Result	<input checked="" type="checkbox"/> Pass <input type="checkbox"/> Fail

Test Data Yes N/A
Test Plot Yes (See below) N/A

LTE Band 5 (part 27)

BW(MHz)	Frequency (MHz)	Mode	Modulation	Conducted Power (dBm)		Peak-Average Ratio (PAR)
				Peak	Average	
1.4	1732.5	RB 1/0	QPSK	22.97	22.6	0.37
			16QAM	22.29	21.85	0.44
3	1732.5	RB 1/0	QPSK	23.13	22.65	0.48
			16QAM	21.99	21.6	0.39
5	1732.5	RB 1/0	QPSK	23.04	22.57	0.47
			16QAM	22.11	21.61	0.5
10	1732.5	RB 1/0	QPSK	22.73	22.43	0.3
			16QAM	21.9	21.55	0.35

LTE Band 7 (part 27)

BW(MHz)	Frequency (MHz)	Mode	Modulation	Conducted Power (dBm)		Peak-Average Ratio (PAR)
				Peak	Average	
1.4	1732.5	RB 1/0	QPSK	22.9	22.6	0.3
			16QAM	22.32	21.85	0.47
3	1732.5	RB 1/0	QPSK	23.04	22.65	0.39
			16QAM	21.93	21.6	0.33
5	1732.5	RB 1/0	QPSK	23.02	22.57	0.45
			16QAM	21.91	21.61	0.3
10	1732.5	RB 1/0	QPSK	22.84	22.43	0.41
			16QAM	21.9	21.55	0.35

6.4 Occupied Bandwidth

Temperature	26 °C
Relative Humidity	57%
Atmospheric Pressure	1025mbar
Test date :	October 25, 2017
Tested By :	Loren Luo

Requirement(s):

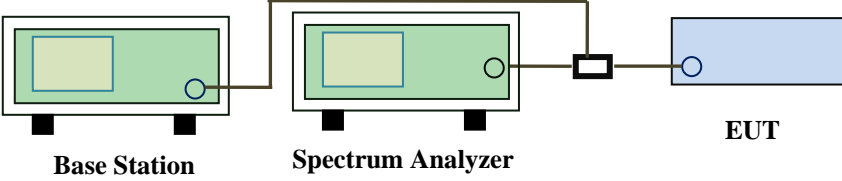
Spec	Item	Requirement	Applicable
§2.1049, §22.917, §22.905 §24.238 §27.53(a)	a)	99% Occupied Bandwidth(kHz)	<input checked="" type="checkbox"/>
	b)	26 dB Bandwidth(kHz)	<input checked="" type="checkbox"/>
Test Setup	 <p style="text-align: center;"> Base Station Spectrum Analyzer EUT </p>		
Test Procedure	<ul style="list-style-type: none"> - The EUT was connected to Spectrum Analyzer and Base Station via power divider. - The 99% and 26 dB occupied bandwidth (BW) of the middle channel for the highest RF powers. 		
Remark			
Result	<input checked="" type="checkbox"/> Pass <input type="checkbox"/> Fail		

Test Data Yes N/A

Test Plot Yes (See below) N/A

LTE Band 5 (Part 22H)

BW(MHz)	Channel	Frequency (MHz)	Modulation	99% Occupied Bandwidth (MHz)	26 dB Bandwidth (MHz)
1.4	20407	824.7	16QAM	1.1051	1.278
			QPSK	1.0978	1.263
1.4	20525	936.5	16QAM	1.1047	1.265
			QPSK	1.1027	1.271
1.4	20643	949.3	16QAM	1.0970	1.286
			QPSK	1.1054	1.286
3	20415	825.5	16QAM	2.7416	3.037
			QPSK	2.7377	3.036
3	20525	936.5	16QAM	2.7455	3.026
			QPSK	2.7333	3.049
3	20635	847.5	16QAM	2.7407	3.045
			QPSK	2.7515	3.022
5	20425	826.5	16QAM	4.5170	5.053
			QPSK	4.5231	5.995
5	20525	936.5	16QAM	4.5179	5.068
			QPSK	4.5215	5.032
5	20625	846.5	16QAM	4.5258	5.064
			QPSK	4.5208	5.001
10	20450	829	16QAM	9.0713	10.16
			QPSK	9.0648	10.05
10	20525	936.5	16QAM	9.0642	10.10
			QPSK	9.0649	10.06
10	20800	844	16QAM	9.0878	10.10
			QPSK	9.1122	10.14

LTE Band 7 (Part 27) result

BW(MHz)	Channel	Frequency (MHz)	Modulation	99% Occupied Bandwidth (MHz)	26 dB Bandwidth (MHz)
5	20775	2502.5	16QAM	4.5478	5.064
			QPSK	4.5456	5.070
5	21100	2535	16QAM	4.5214	5.050
			QPSK	4.5278	5.065
5	21425	2567.5	16QAM	4.5125	5.054
			QPSK	4.5112	5.054
10	20800	2505	16QAM	9.0488	10.01
			QPSK	9.0382	10.05
10	21100	2535	16QAM	9.0568	10.04
			QPSK	9.0439	10.08
10	21400	2562.5	16QAM	9.0555	10.02
			QPSK	9.0068	10.02
15	20825	2507.5	16QAM	13.422	14.66
			QPSK	13.447	14.75
15	21100	2535	16QAM	13.507	14.82
			QPSK	13.504	14.89
15	21400	2562.5	16QAM	13.460	14.70
			QPSK	13.467	14.79
20	20850	2510	16QAM	17.920	19.18
			QPSK	17.933	19.30
20	21100	2535	16QAM	17.891	19.29
			QPSK	17.919	19.30
20	21350	2560	16QAM	17.941	19.25
			QPSK	17.949	19.25

Test Plots

LTE Band 5 (Part 22H)

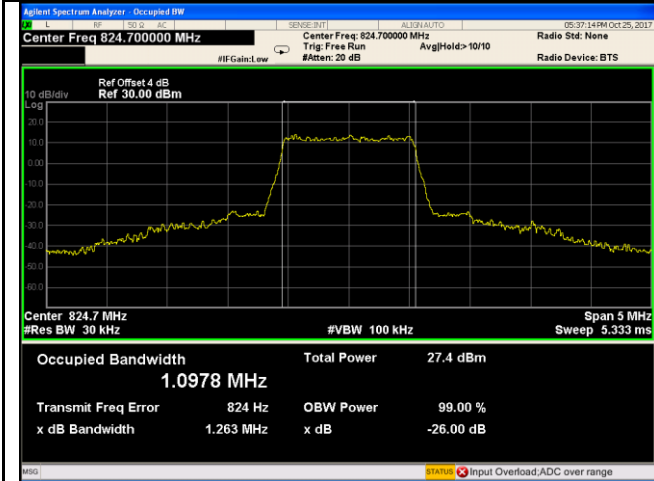

LTE band 5 - Low CH QPSK-1.4

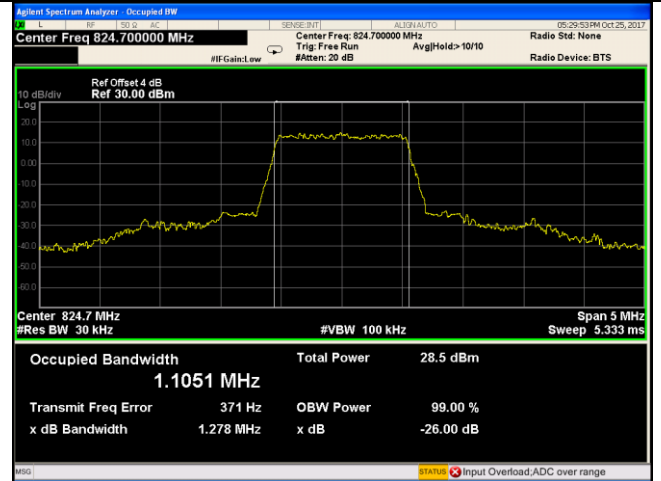

LTE band 5 - Low CH 16QAM-1.4

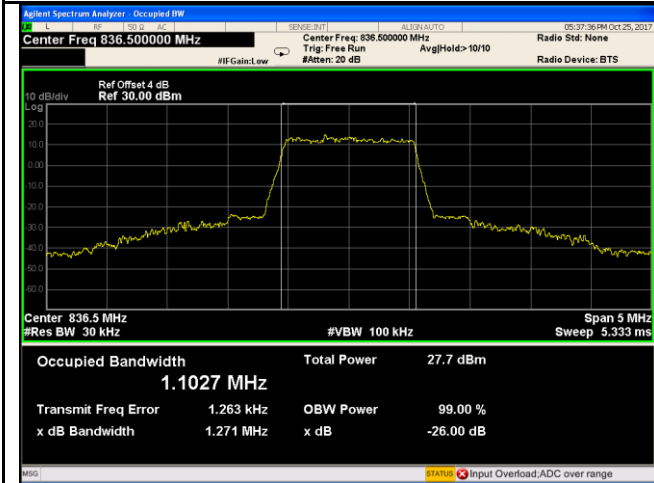

LTE band 5 - Middle CH QPSK-1.4

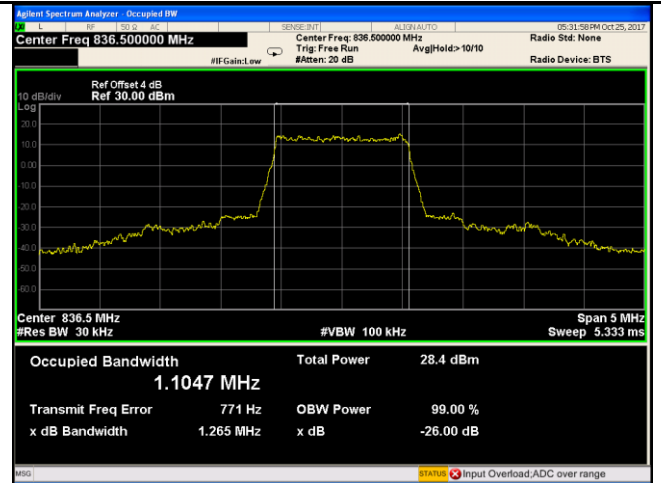

LTE band 5 - Middle CH 16QAM-1.4

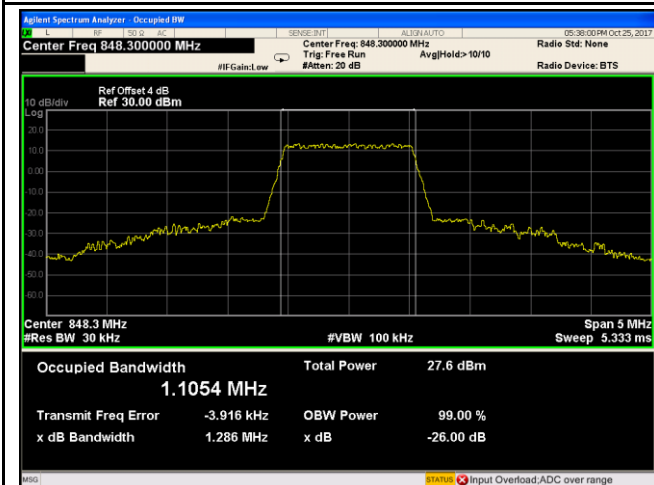

LTE band 5 - High CH QPSK-1.4

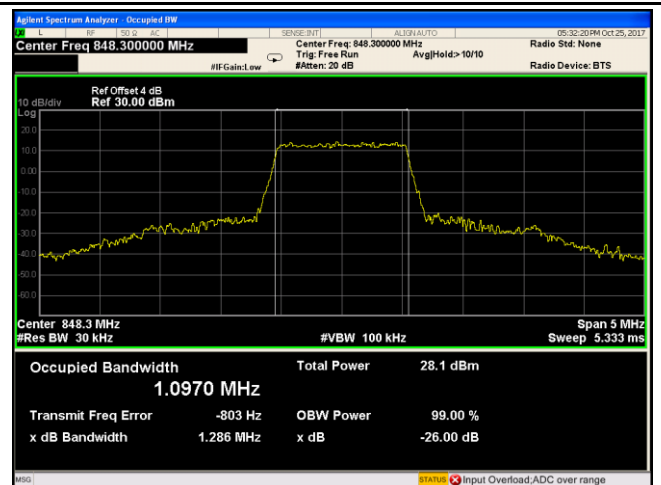

LTE band 5 - High CH 16QAM-1.4

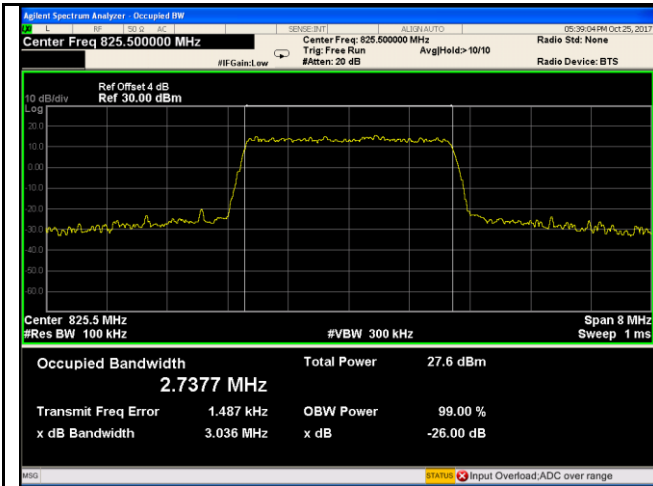

LTE band 5 - Low CH QPSK-3

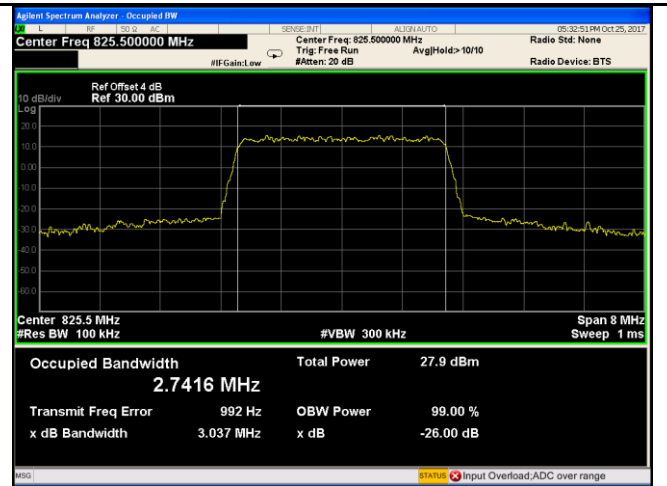

LTE band 5 - Low CH 16QAM-3

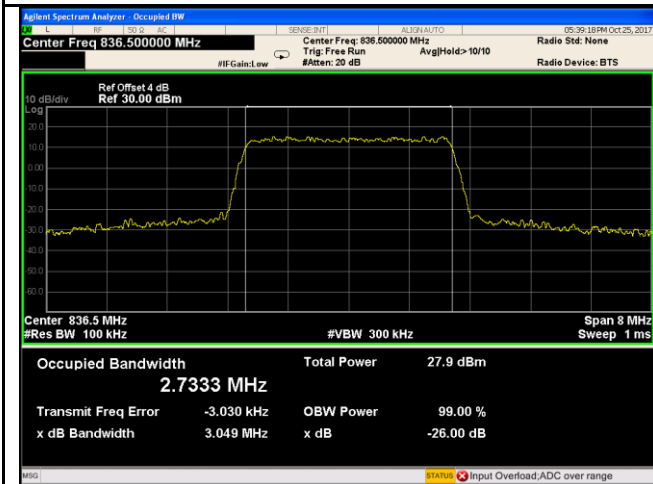

LTE band 5 - Middle CH QPSK-3

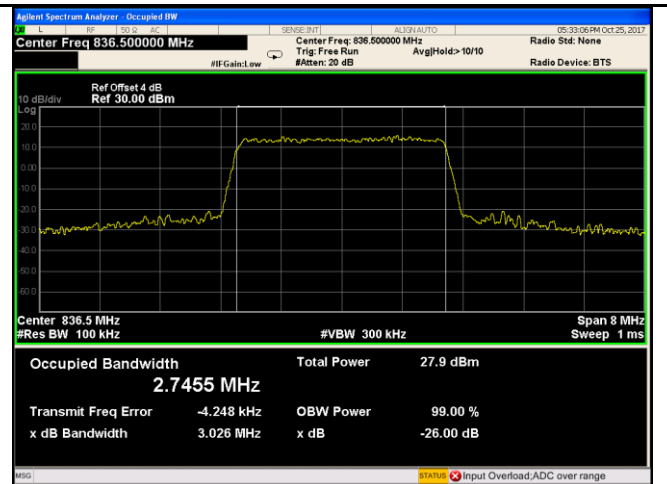

LTE band 5 - Middle CH 16QAM-3

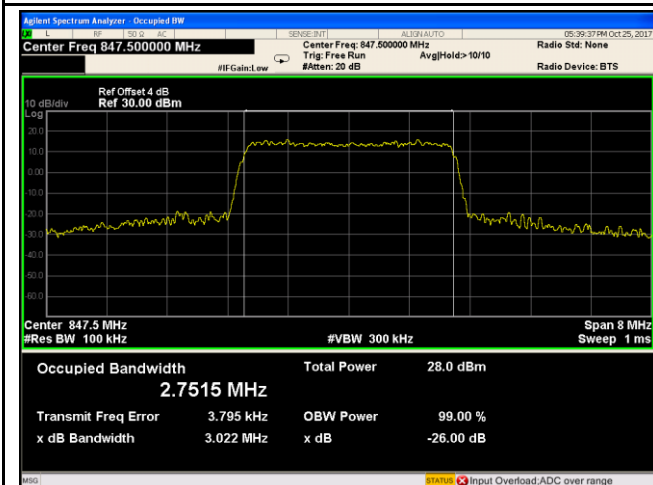

LTE band 5 - High CH QPSK-3

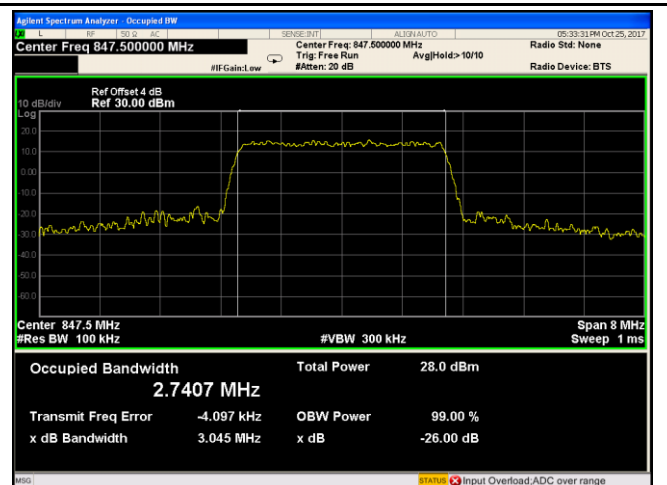

LTE band 5 - High CH 16QAM-3

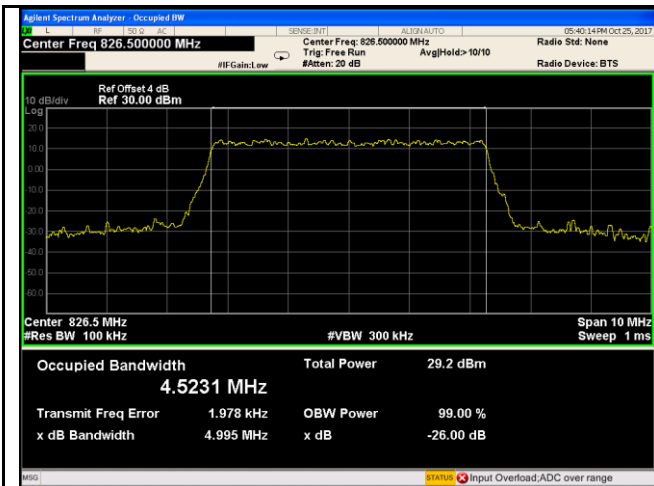

LTE band 5 - Low CH QPSK-5

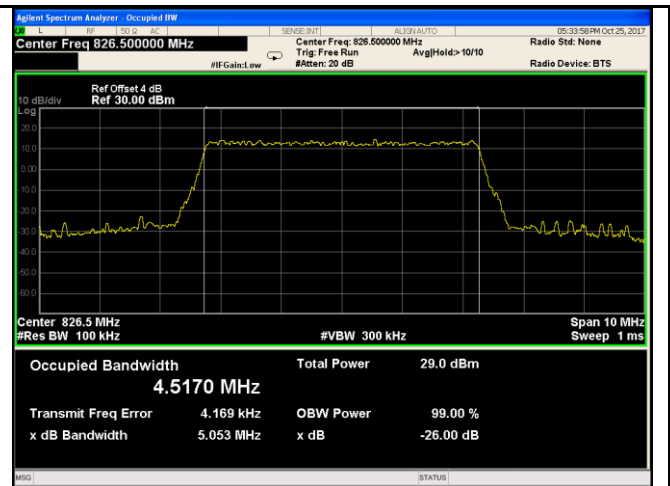

LTE band 5 - Low CH 16QAM-5

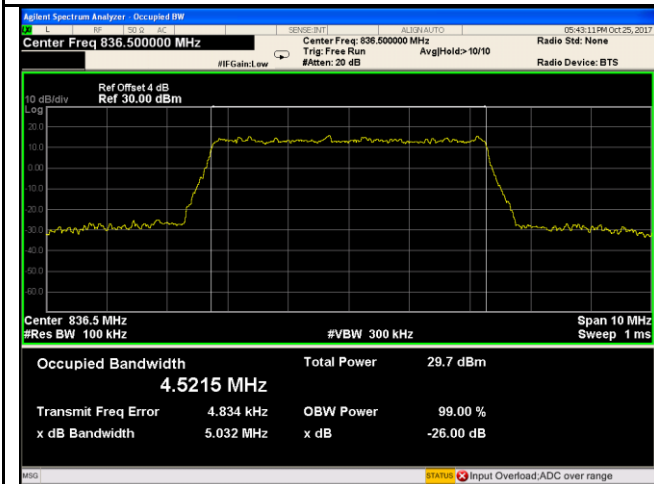

LTE band 5 - Middle CH QPSK-5

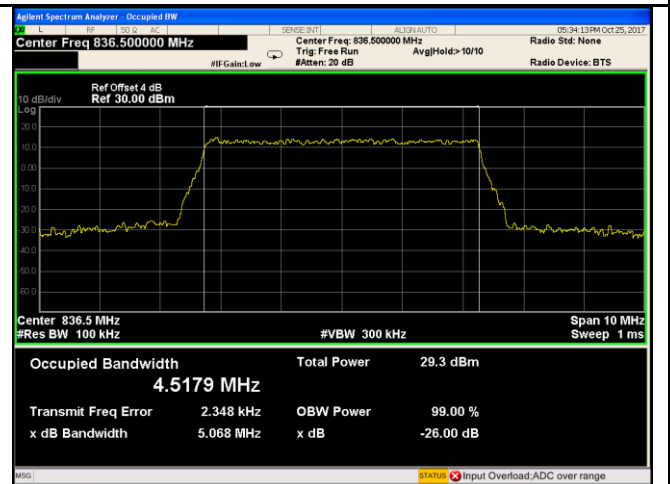

LTE band 5 - Middle CH 16QAM-5

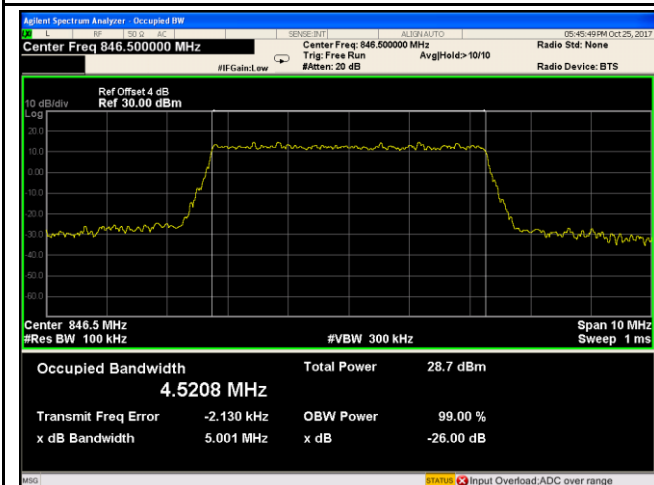

LTE band 5 - High CH QPSK-5

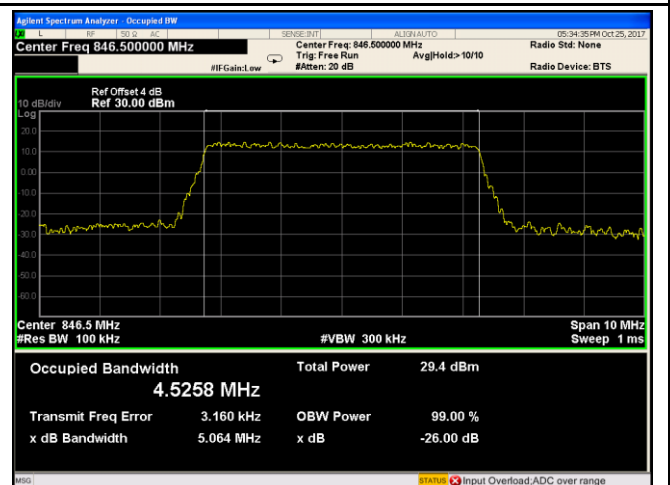

LTE band 5 - High CH 16QAM-5

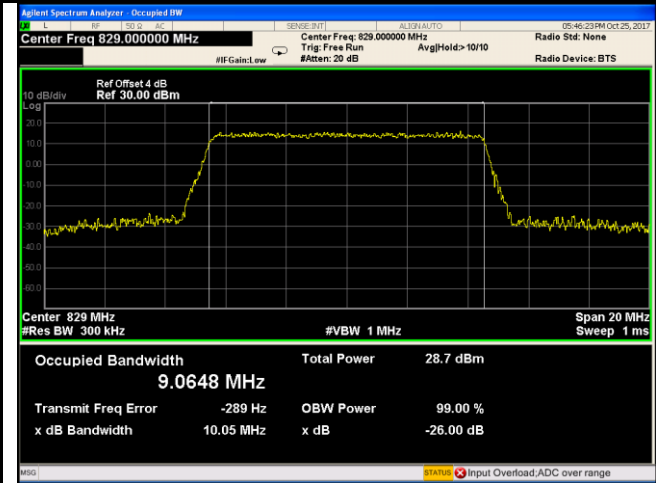

LTE band 5 - Low CH QPSK-10

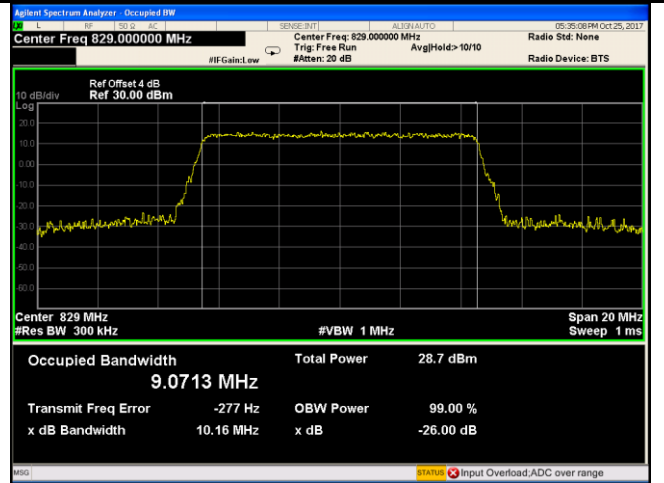

LTE band 5 - Low CH 16QAM-10

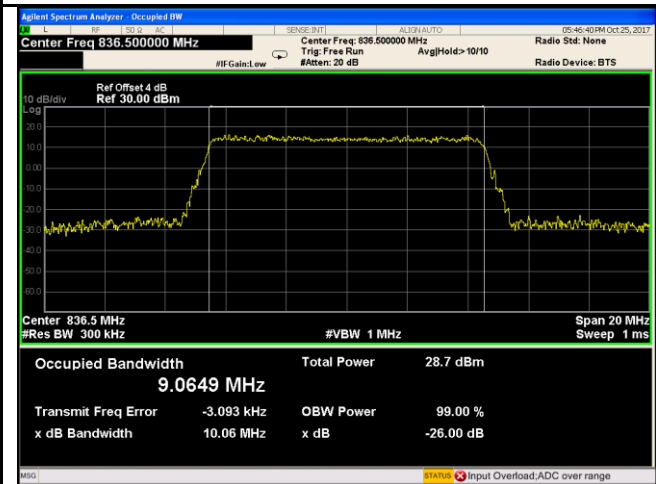

LTE band 5 - Middle CH QPSK-10

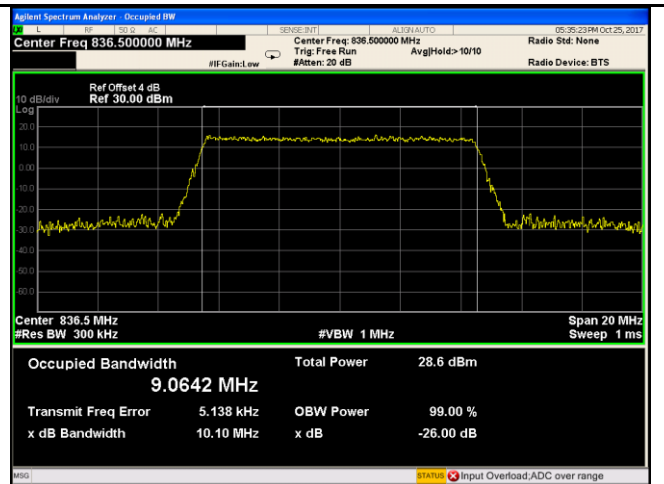

LTE band 5 - Middle CH 16QAM-10

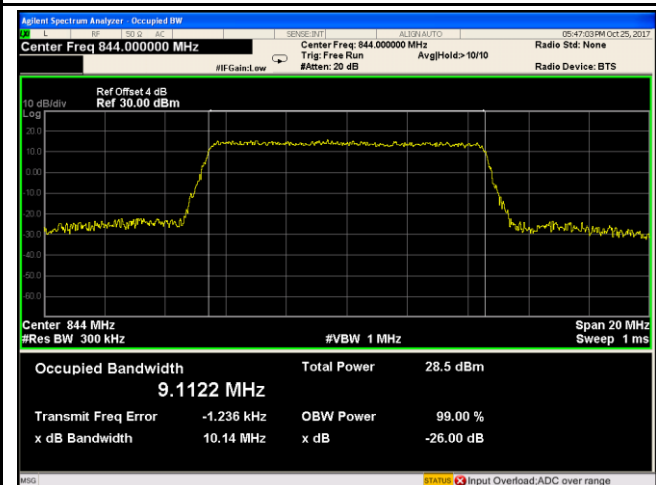

LTE band 5 - High CH QPSK-10

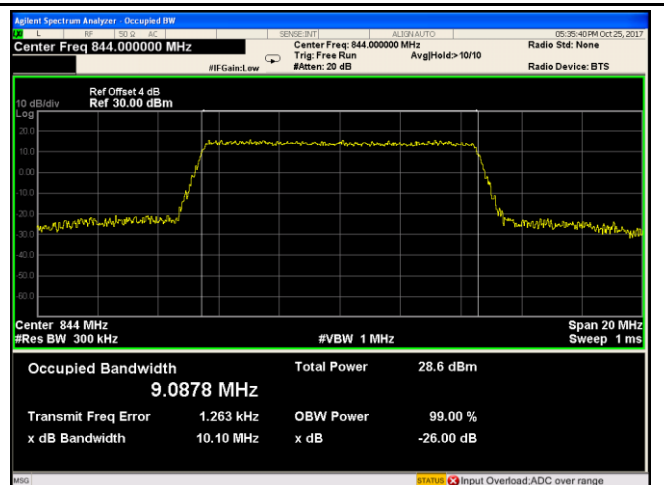

LTE band 5 - High CH 16QAM-10

LTE Band 7 (Part 27)

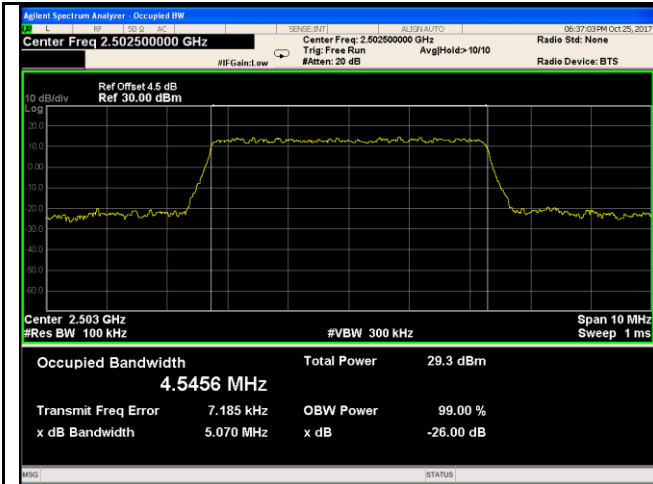

LTE band 7 - Low CH QPSK-5

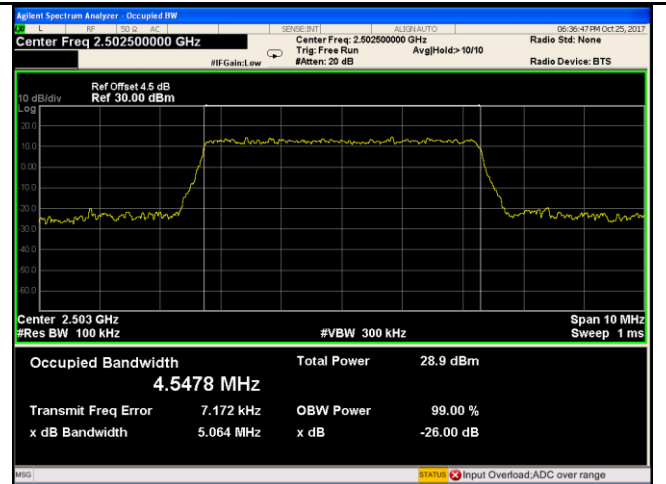

LTE band 7 - Low CH 16QAM-5

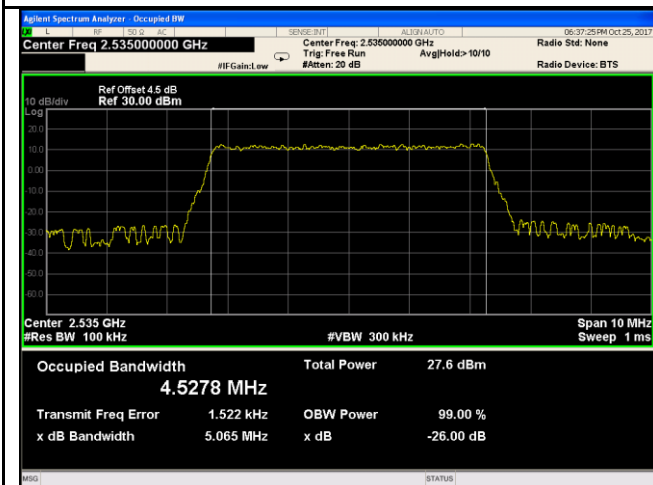

LTE band 7 - Middle CH QPSK-5

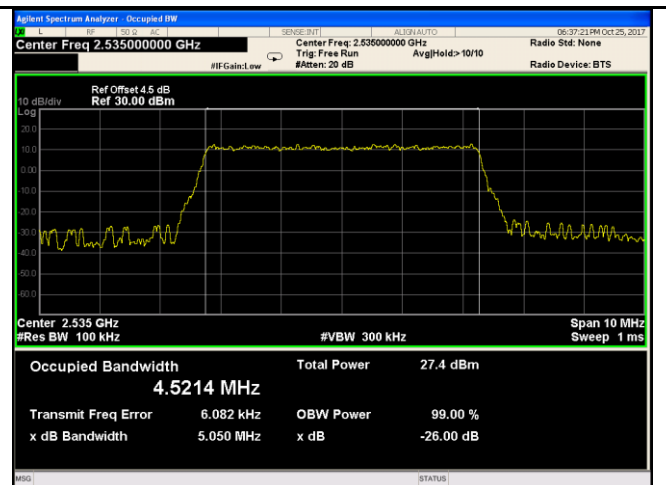

LTE band 7 - Middle CH 16QAM-5

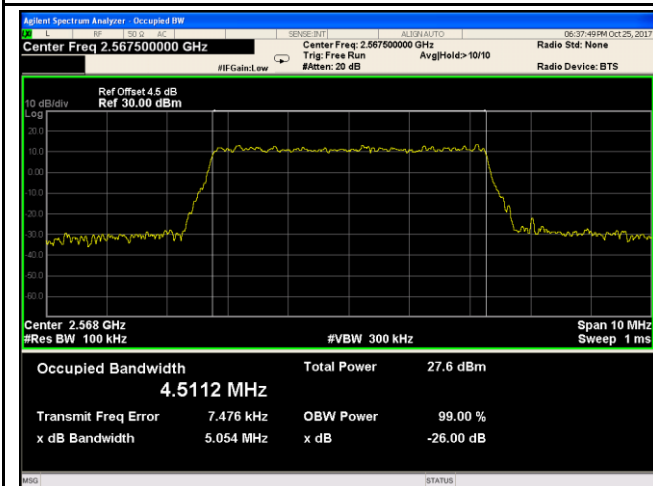

LTE band 7 - High CH QPSK-5

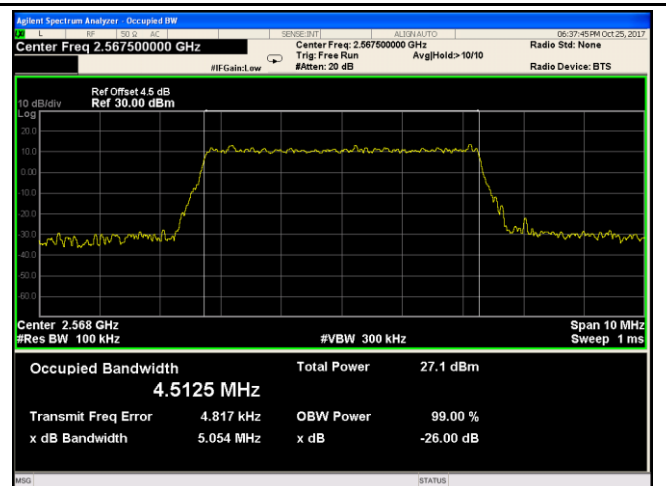

LTE band 7 - High CH 16QAM-5

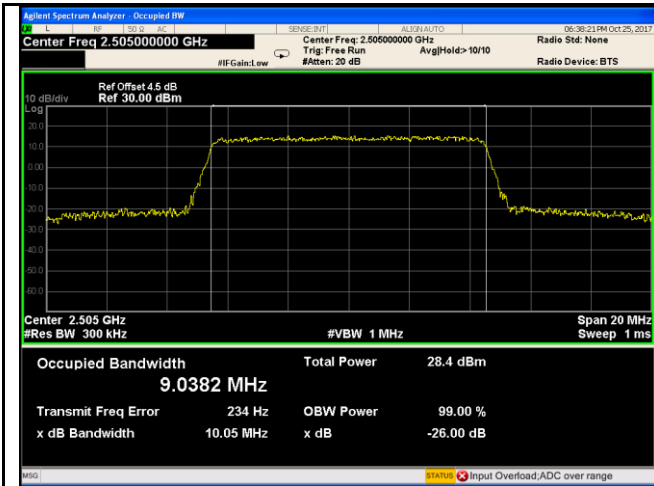

LTE band 7 - Low CH QPSK-10

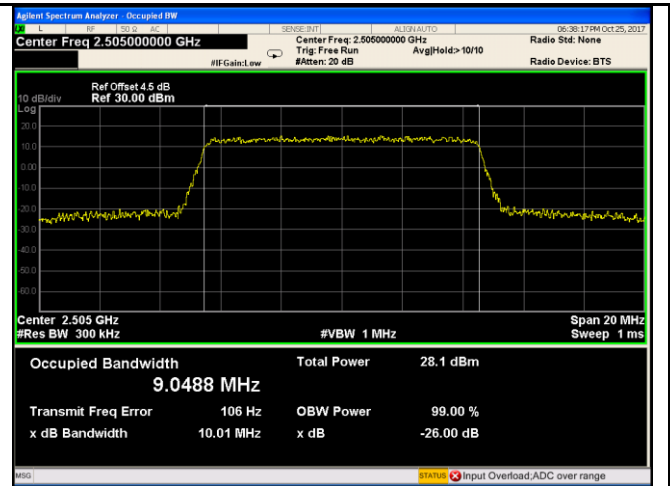

LTE band 7 - Low CH 16QAM-10

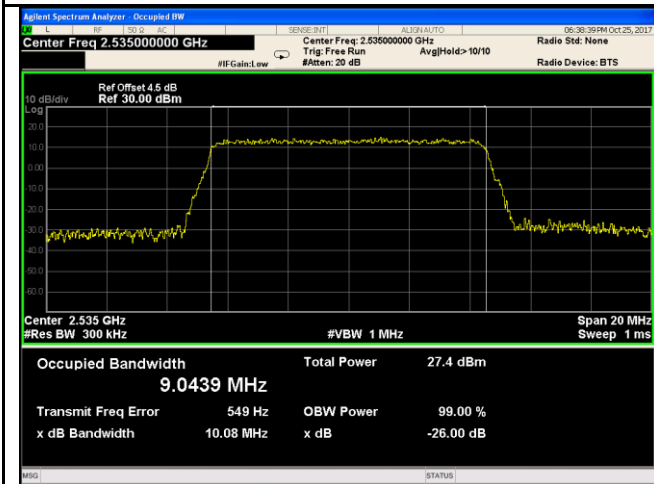

LTE band 7 - Middle CH QPSK-10

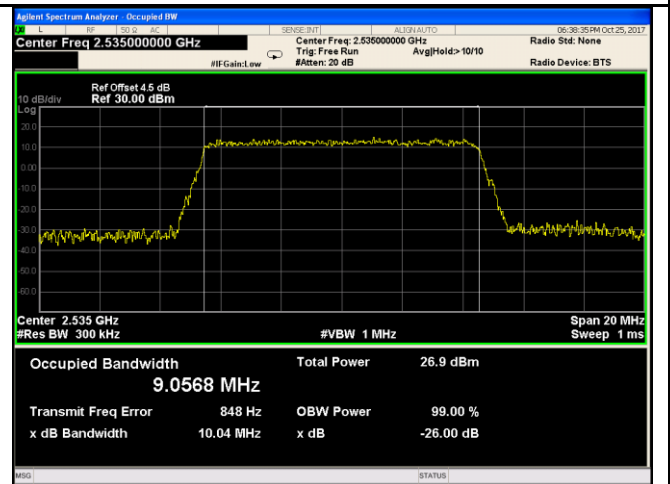

LTE band 7 - Middle CH 16QAM-10

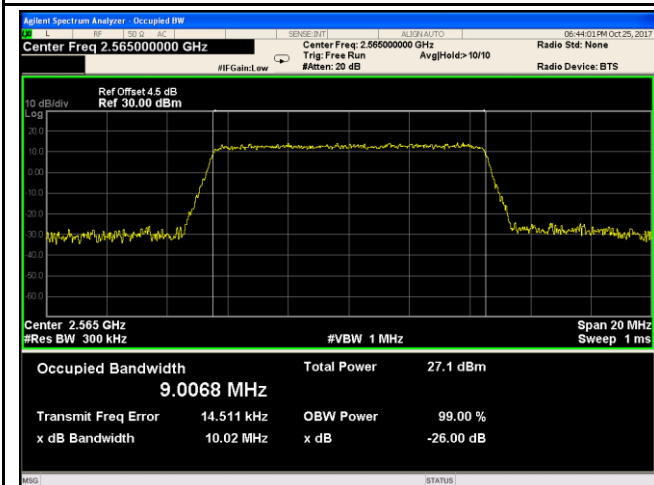

LTE band 7 - High CH QPSK-10

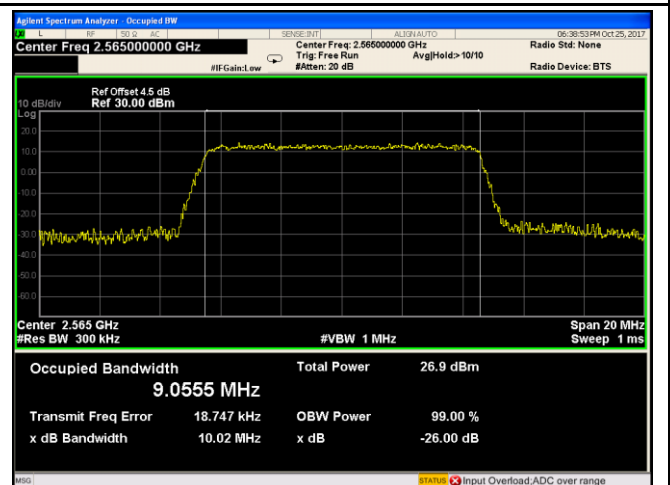

LTE band 7 - High CH 16QAM-10

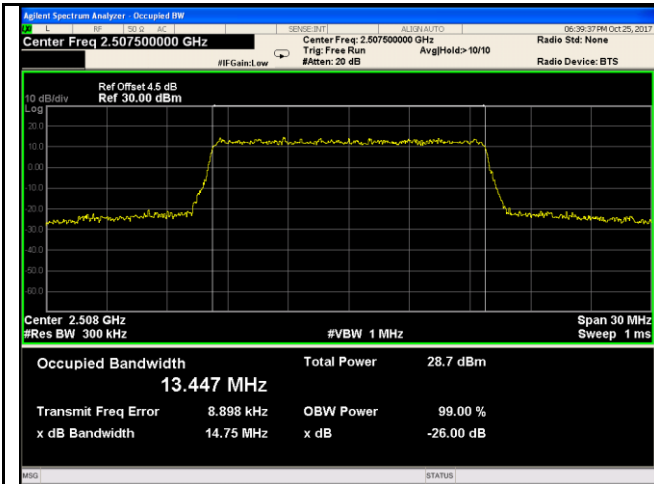

LTE band 7 - Low CH QPSK-15

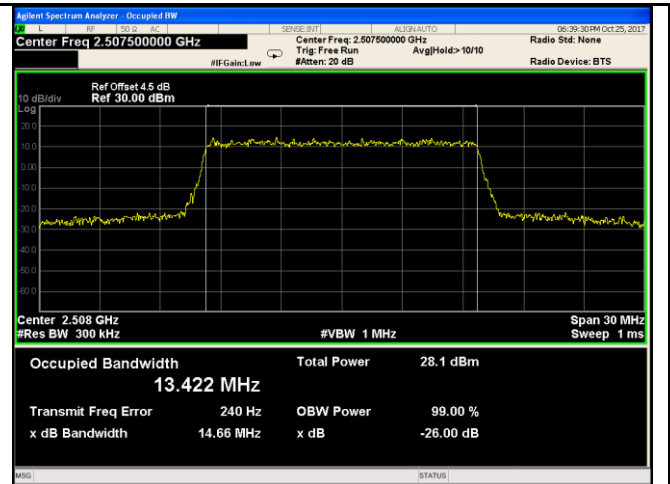

LTE band 7 - Low CH 16QAM-15

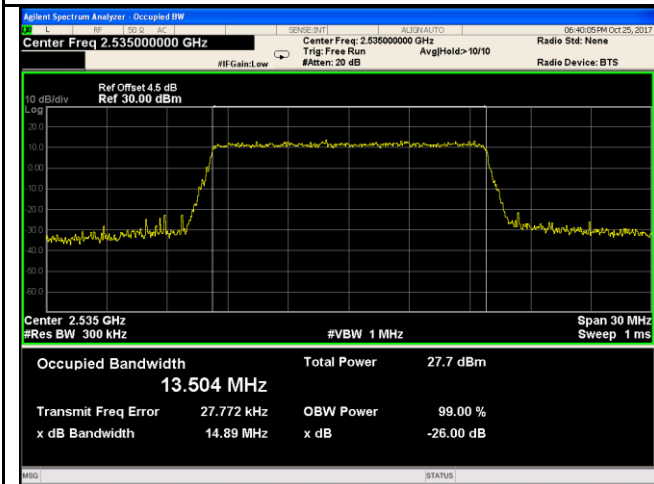

LTE band 7 - Middle CH QPSK-15

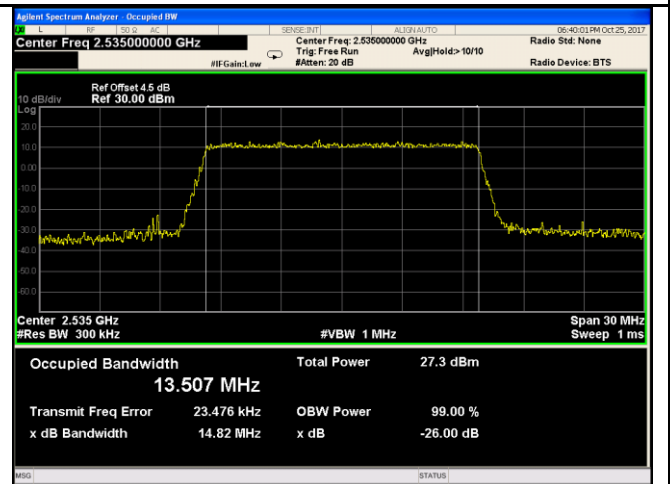

LTE band 7 - Middle CH 16QAM-15

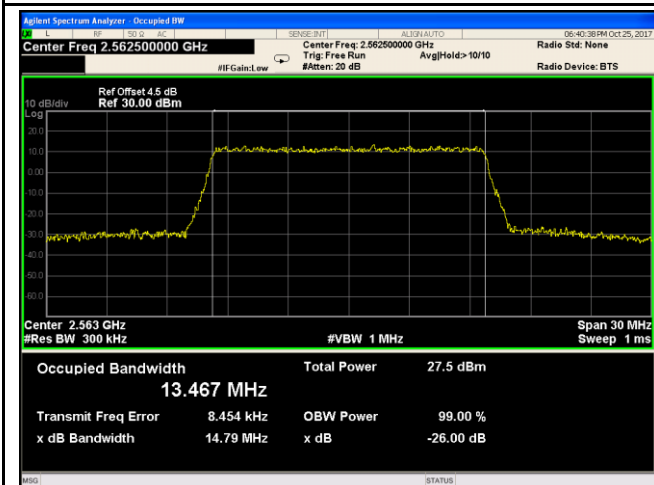

LTE band 7 - High CH QPSK-15

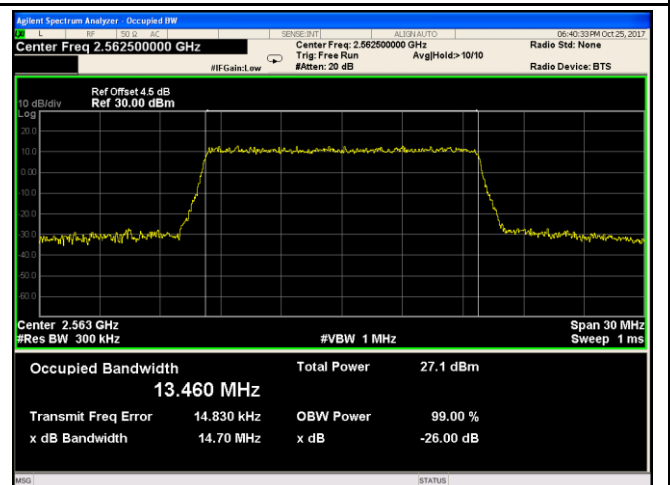

LTE band 7 - High CH 16QAM-15

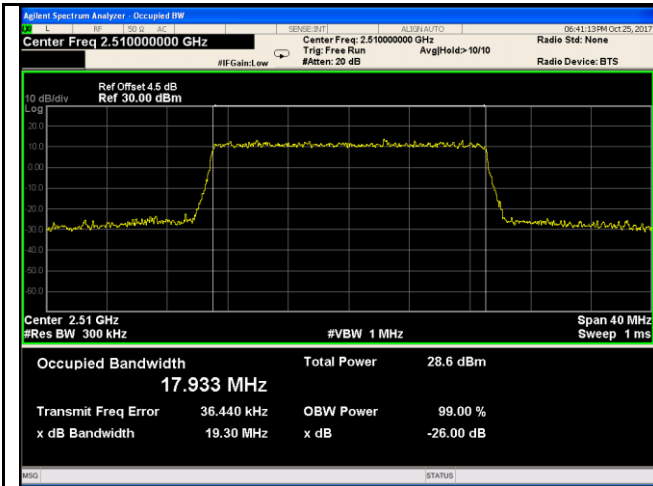

LTE band 7 - Low CH QPSK-20

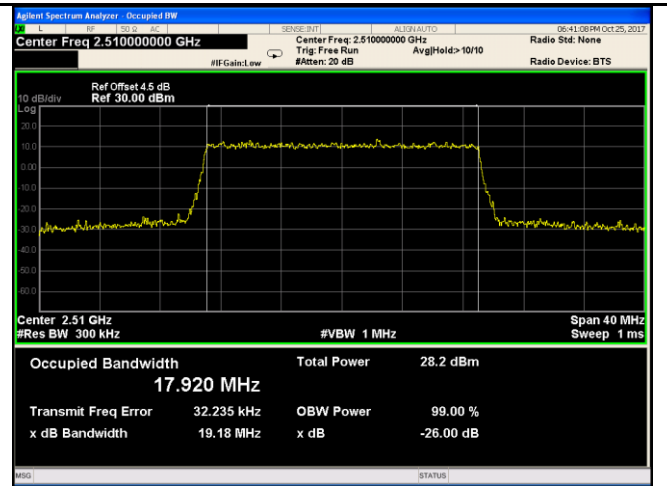

LTE band 7 - Low CH 16QAM-20

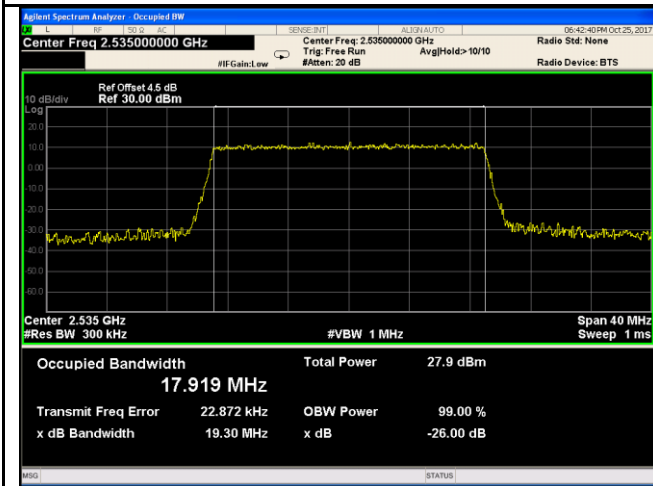

LTE band 7 - Middle CH QPSK-20

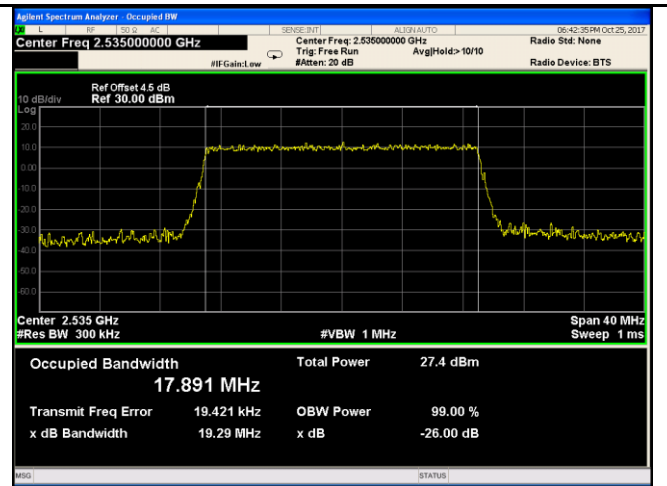

LTE band 7 - Middle CH 16QAM-20

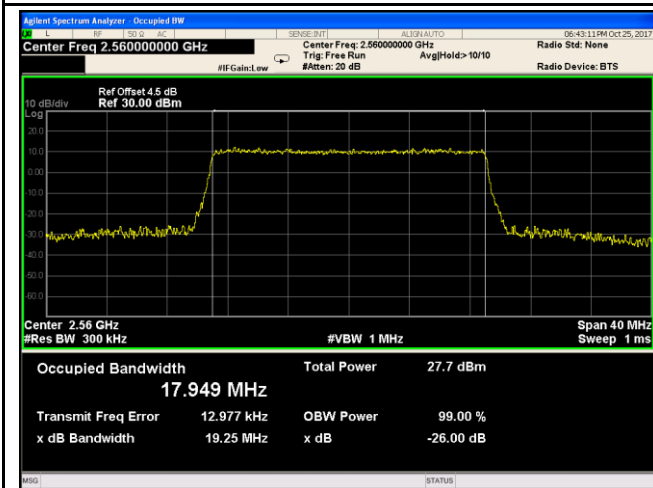

LTE band 7 - High CH QPSK-20

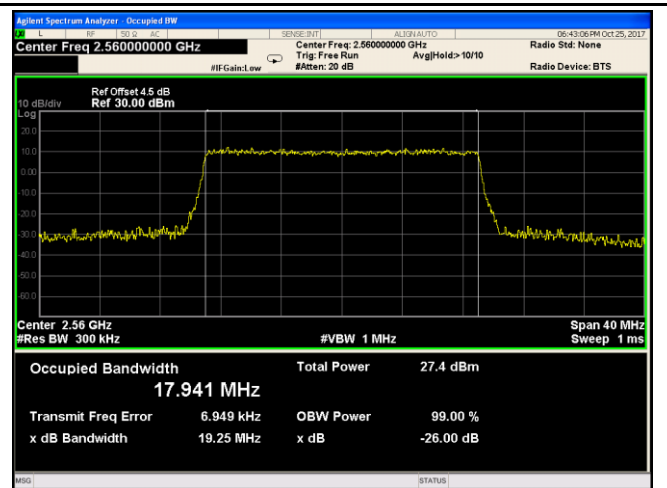

LTE band 7 - High CH 16QAM-20

6.5 Spurious Emissions at Antenna Terminals

Temperature	26 °C
Relative Humidity	57%
Atmospheric Pressure	1025mbar
Test date :	October 25, 2017
Tested By :	Loren Luo

Requirement(s):

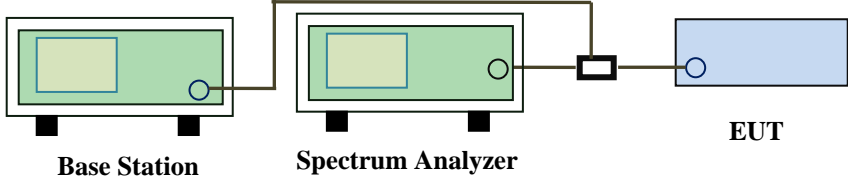
Spec	Item	Requirement	Applicable
§2.1051, §22.917(a)& §24.238(a) § 27.53(h)	a)	The power of any emission outside of the authorized operating frequency ranges must be lower than the transmitter power (P) by a factor of at least $43 + 10 \log(P)$ dB	<input checked="" type="checkbox"/>
Test Setup	 <p style="text-align: center;">Base Station Spectrum Analyzer EUT</p>		
Test Procedure	<ul style="list-style-type: none"> - The EUT was connected to Spectrum Analyzer and Base Station via power divider. - The Band Edges of low and high channels for the highest RF powers were measured. - Setting RBW as roughly BW/100. 		
Remark			
Result	<input checked="" type="checkbox"/> Pass <input type="checkbox"/> Fail		

Test Data Yes N/A
 Test Plot Yes (See below) N/A

Test Plots 30MHz-5GHz
LTE Band 5 (Part 22H)

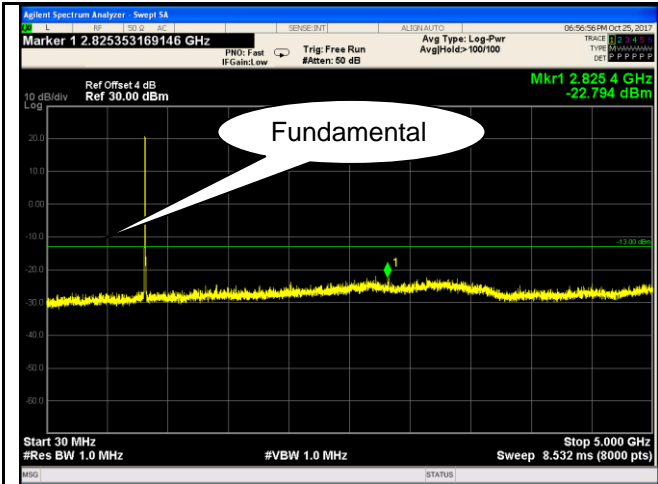

LTE Band 5 - Low Channel-1

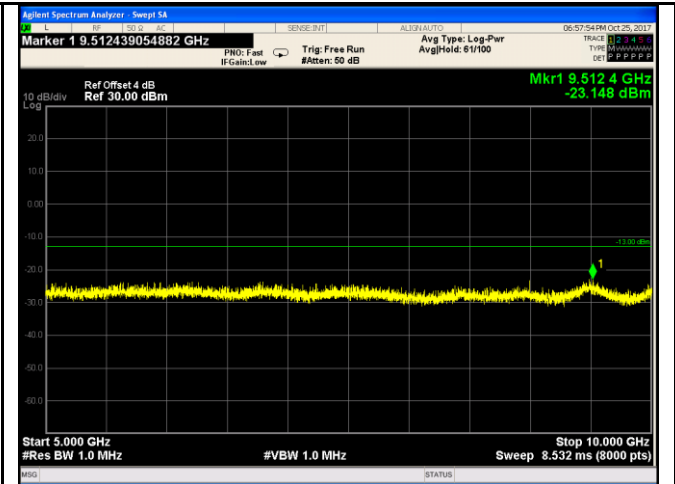

LTE Band 5 - Low Channel-2

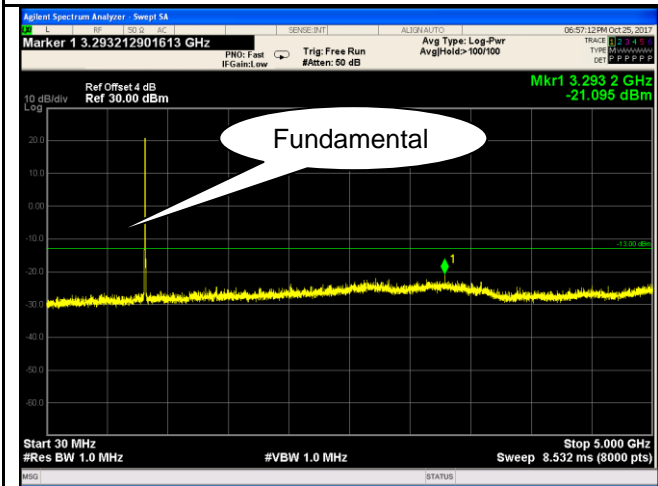

LTE Band 5 - Middle Channel-1

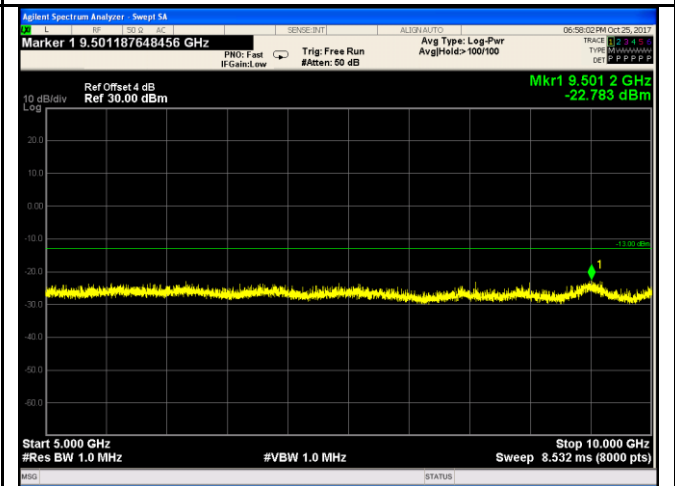

LTE Band 5 - Middle Channel-2

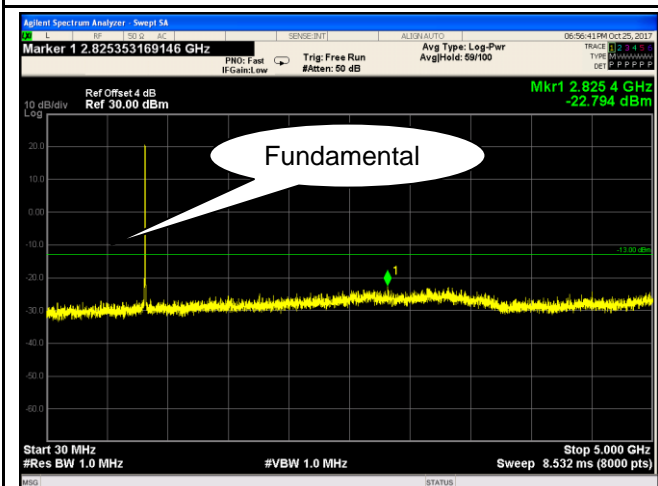

LTE Band 5 - High Channel-1

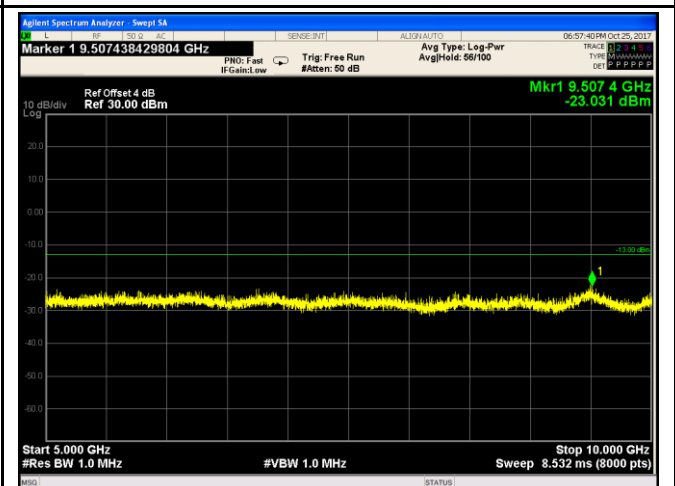

LTE Band 5 - High Channel-2

LTE Band 7 (Part 27)

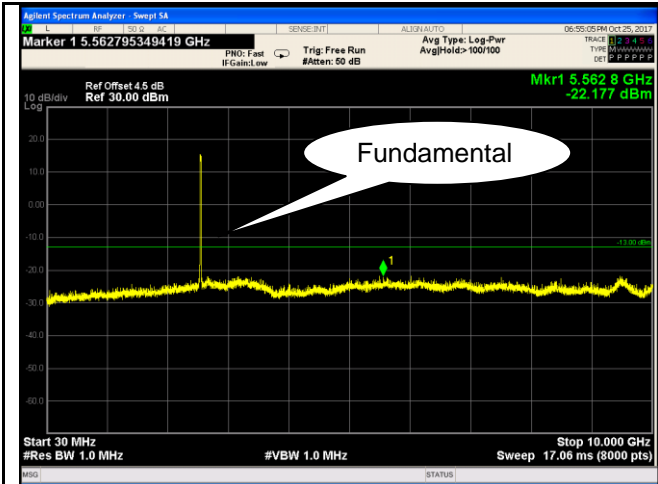

LTE Band 7 - Low Channel-1

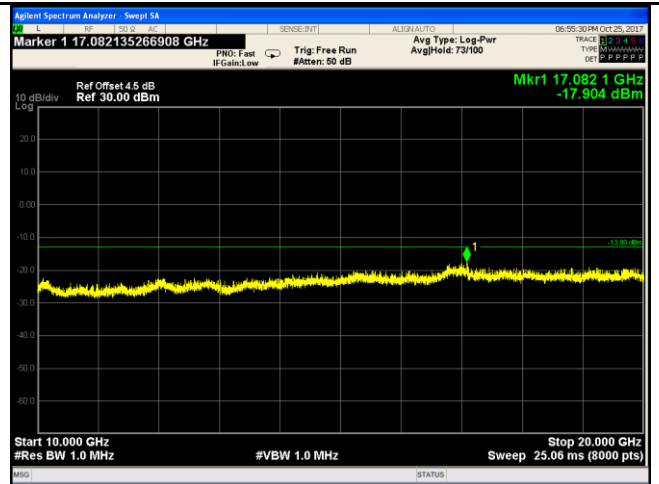

LTE Band 7 - Low Channel-2

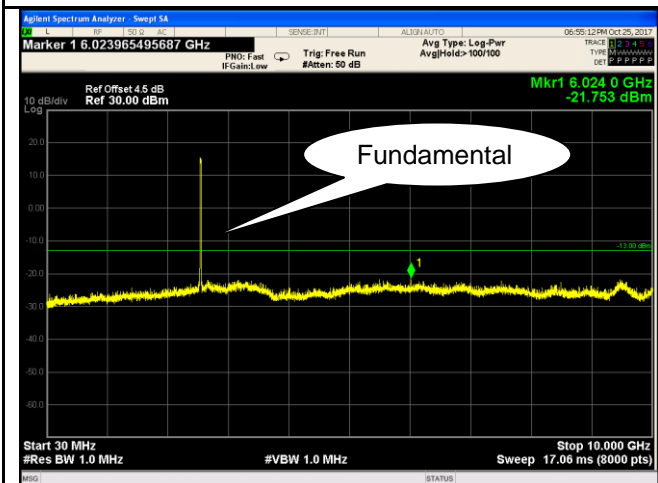

LTE Band 7 - Middle Channel-1

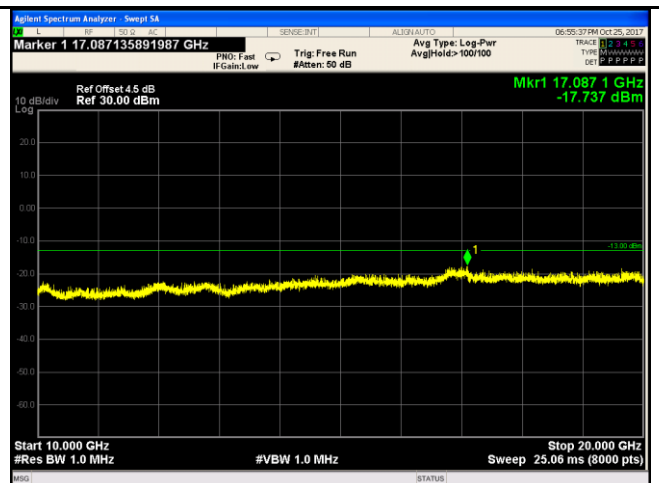

LTE Band 7 - Middle Channel-2

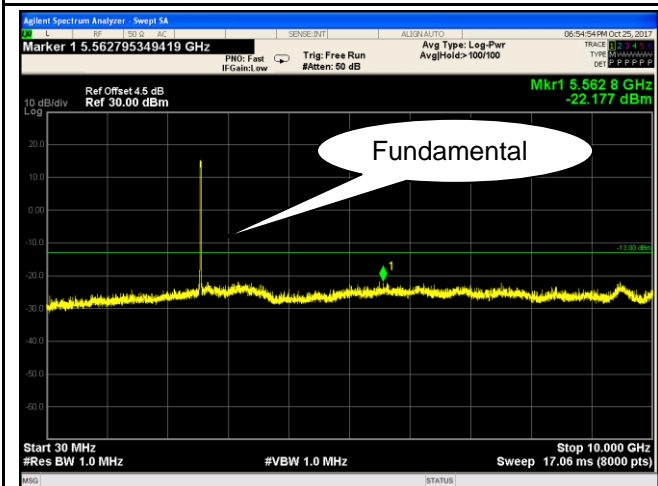

LTE Band 7 - High Channel-1

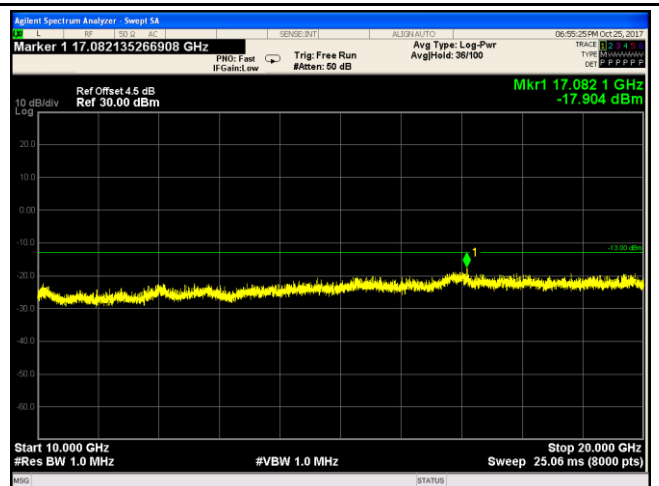

LTE Band 7 - High Channel-2

6.6 Spurious Radiated Emissions

Temperature	25 °C
Relative Humidity	57%
Atmospheric Pressure	1024mbar
Test date :	October 24, 2017
Tested By :	Loren Luo

Requirement(s):

Spec	Item	Requirement	Applicable
§2.1053, §22.917 & §24.238 § 27.53(h)	a)	The power of any emission outside of the authorized operating frequency ranges must be attenuated below the transmitter power (P) by a factor of at least $43 + 10 \log (P)$ dB. The spectrum is scanned from 30 MHz up to a frequency including its 10th harmonic.	<input checked="" type="checkbox"/>

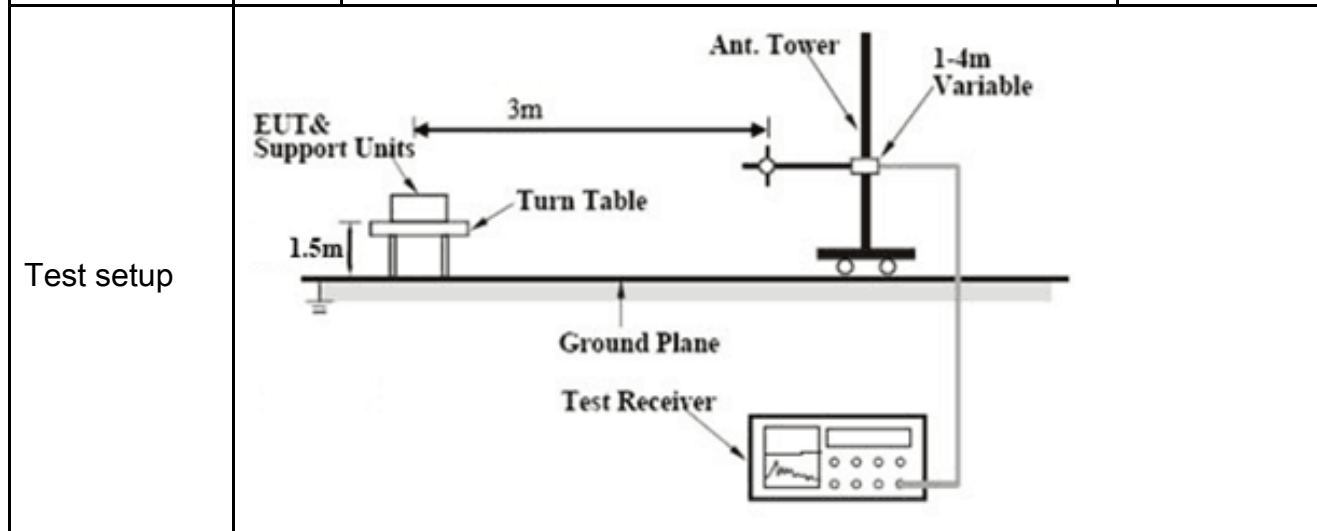

Test Procedure	<ol style="list-style-type: none"> The transmitter was placed on a wooden turntable, and it was transmitting into a non-radiating load which was also placed on the turntable. The measurement antenna was placed at a distance of 3 meters from the EUT. During the tests, the antenna height and polarization as well as EUT azimuth were varied in order to identify the maximum level of emissions from the EUT. The test was performed by placing the EUT on 3-orthogonal axis. Remove the EUT and replace it with substitution antenna. A signal generator was connected to the substitution antenna by a non-radiating cable. The absolute levels of the spurious emissions were measured by the substitution. Sample Calculation: EUT Field Strength = Raw Amplitude (dBµV/m) – Amplifier Gain (dB) + Antenna Factor (dB) + Cable Loss (dB) + Filter Attenuation (dB, if used)
----------------	---

Remark	
Result	<input checked="" type="checkbox"/> Pass <input type="checkbox"/> Fail

Test Data Yes N/A

Test Plot Yes (See below) N/A

LTE Band 5(Part22H) result

Low channel

Frequency (MHz)	Substituted level (dBm)	Polarity (H/V)	Antenna Gain Correction (dB)	Cable Loss (dB)	Corrected Reading (dBm)	Limit (dBm)	Margin (dB)
1658	-46.32	V	7.95	0.78	-39.15	-13	-26.15
1658	-47.16	H	7.95	0.78	-39.99	-13	-26.99
82.3	-65.76	V	0.41	0.08	-65.43	-13	-52.43
730.6	-67.69	H	6.46	0.46	-61.69	-13	-48.69

Middle channel

Frequency (MHz)	Substituted level (dBm)	Polarity (H/V)	Antenna Gain Correction (dB)	Cable Loss (dB)	Corrected Reading (dBm)	Limit (dBm)	Margin (dB)
1673	-45.51	V	7.95	0.78	-38.34	-13	-25.34
1673	-46.02	H	7.95	0.78	-38.85	-13	-25.85
747.7	-66.14	V	6.45	0.44	-60.13	-13	-47.13
888.4	-66.11	H	6.25	0.45	-60.31	-13	-47.31

High channel

Frequency (MHz)	Substituted level (dBm)	Polarity (H/V)	Antenna Gain Correction (dB)	Cable Loss (dB)	Corrected Reading (dBm)	Limit (dBm)	Margin (dB)
1688	-45.93	V	7.95	0.78	-38.76	-13	-25.76
1688	-43.96	H	7.95	0.78	-36.79	-13	-23.79
112.2	-69.43	V	-0.01	0.11	-69.55	-13	-56.55
58.1	-65.35	H	-1.61	0.11	-67.07	-13	-54.07

Note:

1, The testing has been conformed to $10 \times 1907.5\text{MHz} = 19,075\text{MHz}$

2, All other emissions more than 30 dB below the limit

3, X-Axis, Y-Axis and -Axis were investigated. The results above show only the worst case.

4, The radiated spurious test above 18GHz is subcontracted to SIEMIC (Nanjing-China) Laboratories. and found 30dB below the limit at least.

LTE Band 7(Part27) result

Low channel

Frequency (MHz)	Substituted level (dBm)	Polarity (H/V)	Antenna Gain Correction (dB)	Cable Loss (dB)	Corrected Reading (dBm)	Limit (dBm)	Margin (dB)
5020	-46.25	V	10.29	0.98	-36.94	-13	-23.94
5020	-45.33	H	10.29	0.98	-36.02	-13	-23.02
743.3	-67.27	V	6.41	0.44	-61.3	-13	-48.3
885.5	-66.98	H	6.29	0.45	-61.14	-13	-48.14

Middle channel

Frequency (MHz)	Substituted level (dBm)	Polarity (H/V)	Antenna Gain Correction (dB)	Cable Loss (dB)	Corrected Reading (dBm)	Limit (dBm)	Margin (dB)
5070	-46.54	V	10.3	0.99	-37.23	-13	-24.23
5070	-47.62	H	10.3	0.99	-38.31	-13	-25.31
204.4	-64.39	V	3.69	0.19	-60.89	-13	-47.89
50.3	-66.42	H	-4.47	0.12	-71.01	-13	-58.01

High channel

Frequency (MHz)	Substituted level (dBm)	Polarity (H/V)	Antenna Gain Correction (dB)	Cable Loss (dB)	Corrected Reading (dBm)	Limit (dBm)	Margin (dB)
5120	-47.25	V	10.32	1	-37.93	-13	-24.93
5120	-47.92	H	10.32	1	-38.6	-13	-25.6
545.2	-65.95	V	6.46	0.33	-59.82	-13	-46.82
836.7	-65.08	H	6.28	0.47	-59.27	-13	-46.27

Note:

1, The testing has been conformed to $10 \times 1907.5 \text{MHz} = 19,075 \text{MHz}$

2, All other emissions more than 30 dB below the limit

3, X-Axis, Y-Axis and -Axis were investigated. The results above show only the worst case.

4, The radiated spurious test above 18GHz is subcontracted to SIEMIC (Nanjing-China) Laboratories. and found 30dB below the limit at least.

6.7 Band Edge

Temperature	26 °C
Relative Humidity	57%
Atmospheric Pressure	1025mbar
Test date :	October 25, 2017
Tested By :	Loren Luo

Requirement(s):

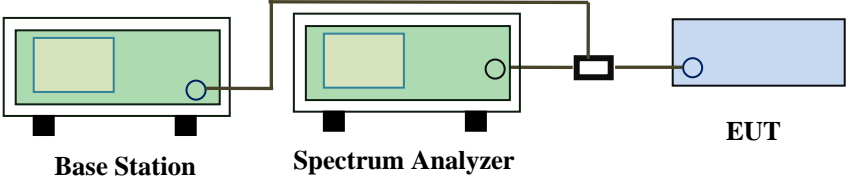
Spec	Item	Requirement	Applicable
§22.917(a) §24.238(a) § 27.53(h)	a)	The power of any emission outside of the authorized operating frequency ranges must be lower than the transmitter power (P) by a factor of at least $43 + 10 \log (P)$ dB.	<input checked="" type="checkbox"/>
Test setup	 <p>The diagram shows a Base Station (green box) connected to a Spectrum Analyzer (green box) and an EUT (blue box) via a power divider. The Base Station and Spectrum Analyzer are connected to each other, and the Spectrum Analyzer is connected to the power divider, which then splits the signal to the EUT.</p>		
Procedure	<ul style="list-style-type: none"> - The EUT was connected to Spectrum Analyzer and Base Station via power divider. - The Band Edges of low and high channels for the highest RF powers were measured. Setting RBW as roughly BW/100. 		
Remark			
Result	<input checked="" type="checkbox"/> Pass <input type="checkbox"/> Fail		

Test Data Yes N/A
 Test Plot Yes (See below) N/A

LTE Band 5 (Part 22H) result

BW(MHz)	Channel	Frequency (MHz)	Mode	Emission (dBm)	Limit (dBm)
1.4	20407	824.7	QPSK	-27.817	-13
			16QAM	-28.074	-13
1.4	20643	848.3	QPSK	-25.651	-13
			16QAM	-25.651	-13
3	20415	825.5	QPSK	-20.715	-13
			16QAM	-22.093	-13
3	20635	847.5	QPSK	-22.882	-13
			16QAM	-22.391	-13
5	20425	826.5	QPSK	-19.305	-13
			16QAM	-19.986	-13
5	20625	846.5	QPSK	-20.974	-13
			16QAM	-20.816	-13
10	20450	829	QPSK	-18.801	-13
			16QAM	-20.791	-13
10	20800	844	QPSK	-18.748	-13
			16QAM	-19.758	-13

Test Plots

LTE Band 5 (Part 22H)

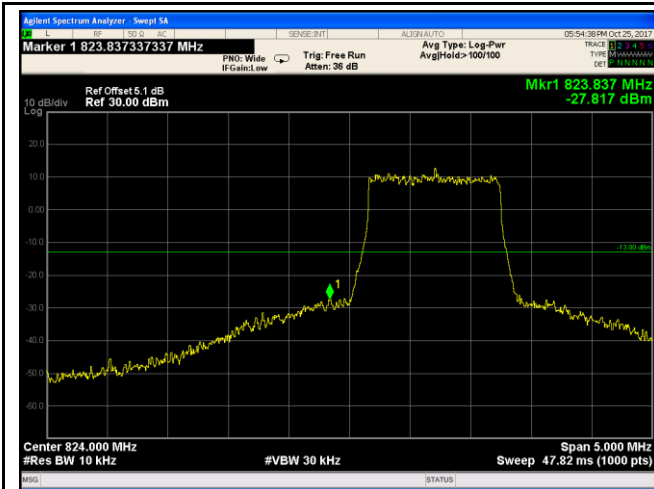

LTE Band 5 - Low Channel QPSK-1.4

Note: Offset=Cable loss (4.5) + 10log
 $(12.78/10)=4.0+1.1=5.6\text{dB}$

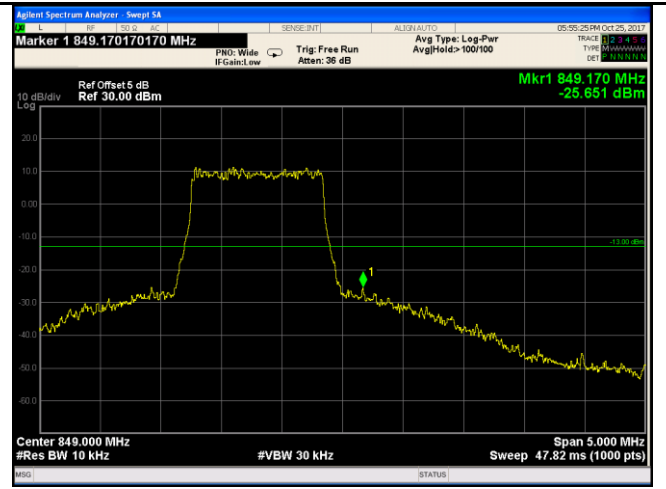

LTE Band 5 - High Channel QPSK-1.4

Note: Offset=Cable loss (4.5) + 10log
 $(12.86/10)=4.0+1.0=5.0\text{dB}$

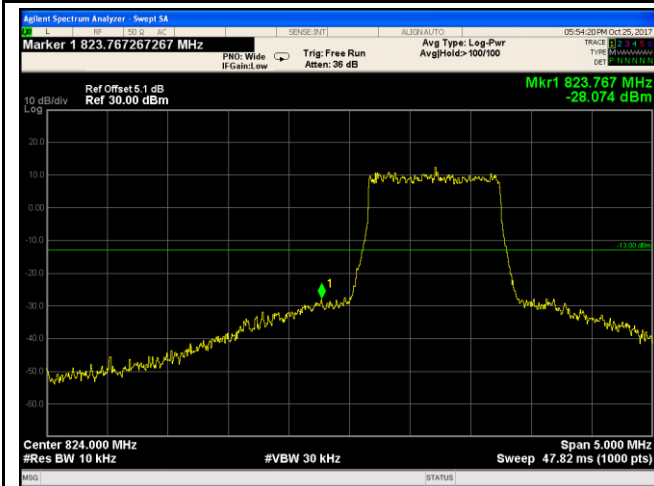

LTE Band 5 - Low Channel 16QAM-1.4

Note: Offset=Cable loss (4.5) + 10log
 $(12.78/10)=4.0+1.1=5.1\text{dB}$

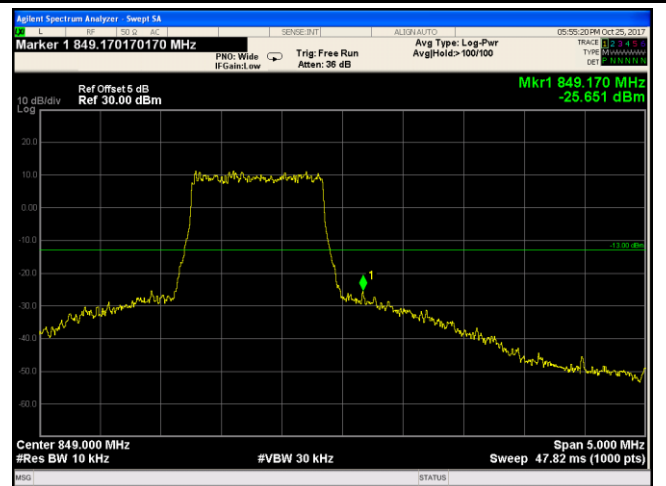

LTE Band 5 - High Channel 16QAM-1.4

Note: Offset=Cable loss (4.5) + 10log
 $(12.86/10)=4.0+1.0=5.0\text{dB}$

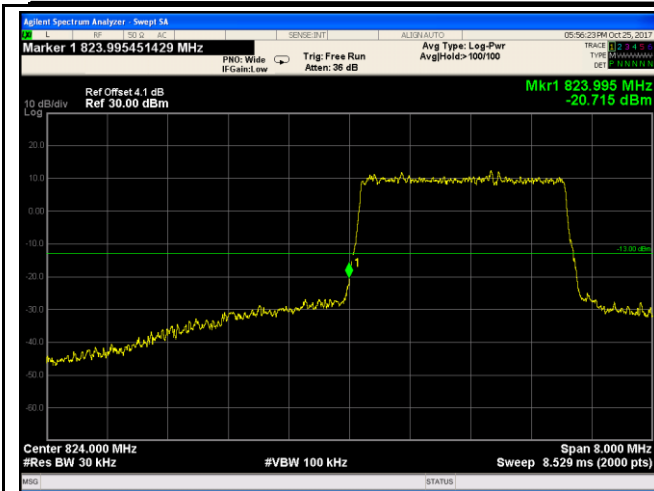

LTE Band 5 - Low Channel QPSK-3

Note: Offset=Cable loss (4.5) + 10log
(30.36/30)=4.0+0.1=4.1dB

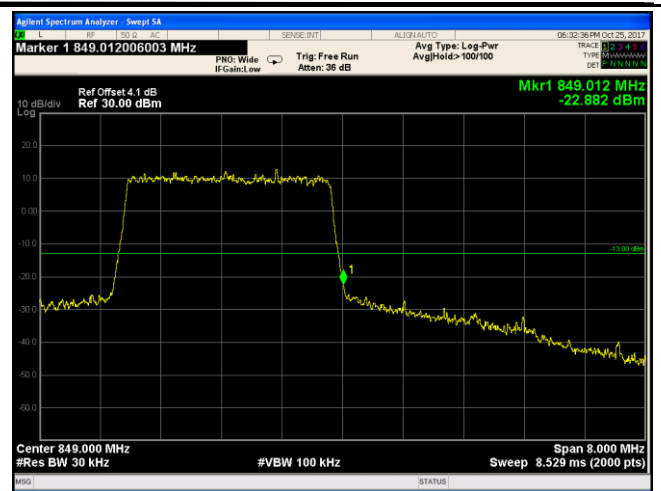

LTE Band 5 - High Channel QPSK-3

Note: Offset=Cable loss (4.5) + 10log
(30.22/30)=4.0+0.1=4.1dB

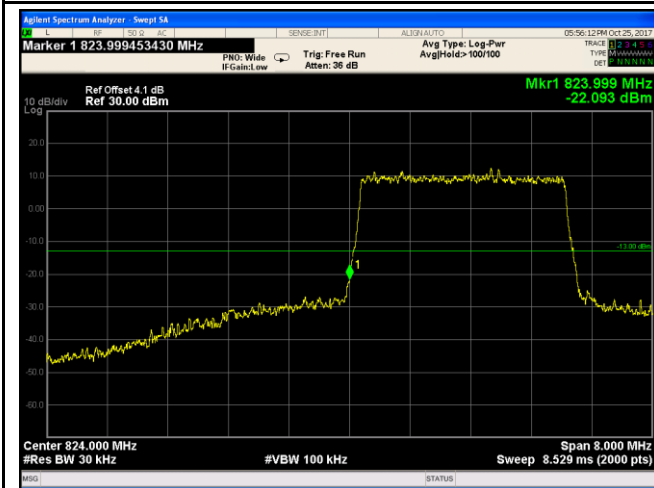

LTE Band 5 - Low Channel 16QAM-3

Note: Offset=Cable loss (4.5) + 10log
(30.37/30)=4.0+0.1=4.1dB

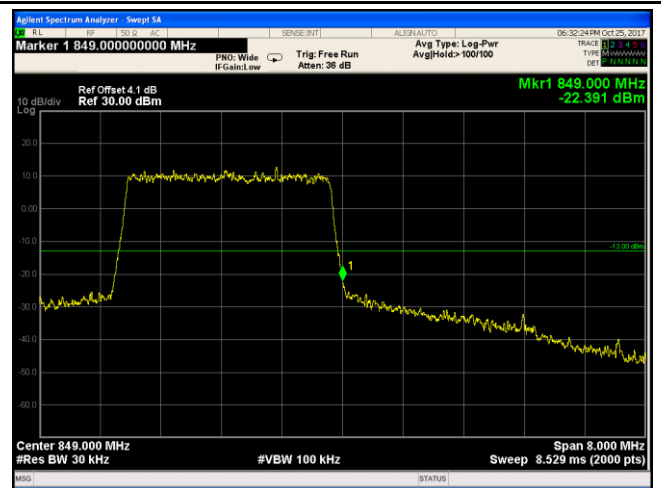

LTE Band 5 - High Channel 16QAM-3

Note: Offset=Cable loss (4.5) + 10log
(30.45/30)=4.0+0.1=4.1dB

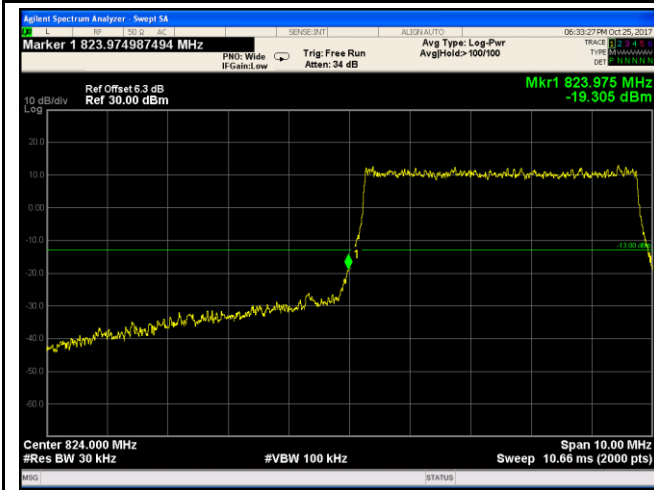

LTE Band 5 - Low Channel QPSK-5

Note: Offset=Cable loss (4.5) + 10log
(59.95/30)=4.0+2.3=6.3dB

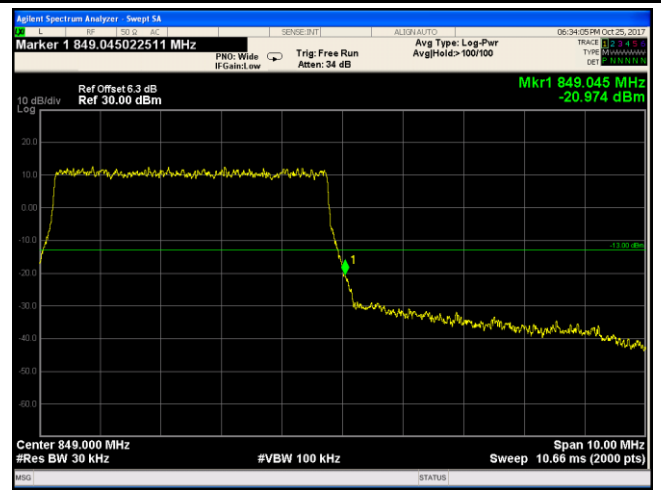

LTE Band 5 - High Channel QPSK-5

Note: Offset=Cable loss (4.5) + 10log
(50.01/30)=4.0+2.3=6.3dB

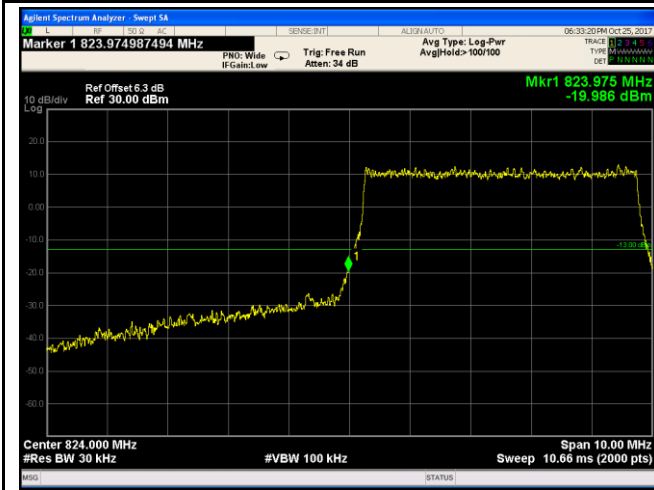

LTE Band 5 - Low Channel 16QAM-5

Note: Offset=Cable loss (4.5) + 10log
(50.53/30)=4.0+2.3=6.3dB

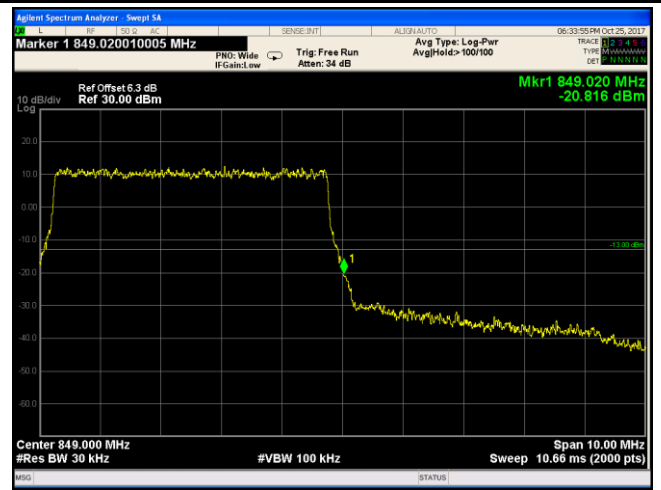

LTE Band 5 - High Channel 16QAM-5

Note: Offset=Cable loss (4.5) + 10log
(50.53/30)=4.0+2.3=6.3dB