



FCC PART 15C TEST REPORT

No. I22Z61292-EMC02

BLU Products, Inc.

Smart Phone

Model Name: B1550VL

with

Hardware Version: V1.0

Software Version: BLU_B1550VL_V12.0.02.05.02.17_FSec

FCC ID: YHLBLUB1550VL

Issued Date: 2022-09-30

Note:

The test results in this test report relate only to the devices specified in this report. This report shall not be reproduced except in full without the written approval of CTTL.

The report must not be used by the client to claim product certification, approval, or endorsement by NVLAP, NIST, or any agency of the U.S. Government.

Test Laboratory:

CTTL, Telecommunication Technology Labs, CAICT

No.52, Huayuan North Road, Haidian District, Beijing, P. R. China 100191.

Tel:+86(0)10-62304633-2512, Fax:+86(0)10-62304633-2504

Email:ctl_terminals@caict.ac.cn, website: www.chinattl.com



CONTENTS

1. TEST LABORATORY	3
1.1. INTRODUCTION & ACCREDITATION	3
1.2. TESTING LOCATION	3
1.3. TESTING ENVIRONMENT	3
1.4. PROJECT DATA	3
1.5. SIGNATURE	3
2. CLIENT INFORMATION	4
2.1. APPLICANT INFORMATION	4
2.2. MANUFACTURER INFORMATION	4
3. EQUIPMENT UNDER TEST (EUT) AND ANCILLARY EQUIPMENT (AE)	5
3.1. ABOUT EUT	5
3.2. INTERNAL IDENTIFICATION OF EUT	5
3.3. INTERNAL IDENTIFICATION OF AE	5
3.4. GENERAL DESCRIPTION	5
4. REFERENCE DOCUMENTS	6
4.1. DOCUMENTS SUPPLIED BY APPLICANT	6
4.2. REFERENCE DOCUMENTS FOR TESTING	6
5. TEST RESULTS	7
5.1. SUMMARY OF TEST RESULTS	7
5.2. STATEMENTS	7
6. TEST EQUIPMENTS UTILIZED	8
7. LABORATORY ENVIRONMENT	9
8. MEASUREMENT UNCERTAINTY	10
8.1. FREQUENCY BAND EDGES - RADIATED	10
8.2. TRANSMITTER SPURIOUS EMISSION - RADIATED	10
8.3. AC POWERLINE CONDUCTED EMISSION	10
ANNEX A: DETAILED TEST RESULTS	11
A.1. FREQUENCY BAND EDGES –RADIATED	11
A.2. TRANSMITTER SPURIOUS EMISSION - RADIATED	14
A.3. AC POWERLINE CONDUCTED EMISSION	19

1. Test Laboratory

1.1. Introduction & Accreditation

Telecommunication Technology Labs, CAICT is an ISO/IEC 17025:2017 accredited test laboratory under NATIONAL VOLUNTARY LABORATORY ACCREDITATION PROGRAM (NVLAP) with lab code 600118-0, and is also an FCC accredited test laboratory (CN5017), and ISED accredited test laboratory (ISED#: 24849). The detail accreditation scope can be found on NVLAP website.

1.2. Testing Location

Radiated testing Location: CTTL(huayuan North Road)

Address: No. 52, Huayuan North Road, Haidian District, Beijing,
P. R. China100191

1.3. Testing Environment

Normal Temperature: 15-35° C

Relative Humidity: 20-75%

1.4. Project data

Testing Start Date: 2022-08-20

Testing End Date: 2022-08-30

1.5. Signature



Wang Xue

(Prepared this test report)



Zhang Ying

(Reviewed this test report)



Zhang Xia

(Approved this test report)



2. Client Information

2.1. Applicant Information

Company Name: BLU Products, Inc.
Address: 10814 NW 33rd St # 100 Doral, FL 33172, USA
Contact Person: Zeng wei
E-Mail: zwei@ctasiasz.com
Telephone: 305.715.7171
FAX: 305.436.8819

2.2. Manufacturer Information

Company Name: BLU Products, Inc.
Address: 10814 NW 33rd St # 100 Doral, FL 33172, USA
Contact Person: Zeng wei
E-Mail: zwei@ctasiasz.com
Telephone: 305.715.7171
FAX: 305.436.8819



3. Equipment Under Test (EUT) and Ancillary Equipment (AE)

3.1. About EUT

Description	Smart Phone
Model Name	B1550VL
Frequency Range	2400MHz~2483.5MHz
Equipment type	Bluetooth® Low Energy
Type of Modulation	GFSK
RF PHY	LE 1M & 2M
Number of Channels	40
Antenna Type	Integrated
Antenna Gain	2.4 dBi
Power Supply	3.85V DC by Battery
FCC ID	YHLBLUB1550VL
Condition of EUT as received	No abnormality in appearance

3.2. Internal Identification of EUT

EUT ID*	IMEI	HW Version	SW Version	Receive Date
UT41a	350547790007484	V1.0	BLU_B1550VL_V12. 0.02.05.02.17_FSec	2022-08-10

*EUT ID: is used to identify the test sample in the lab internally.

3.3. Internal Identification of AE

AE ID*	Description	SN
AE1	Battery	/
AE2	Charger	/
AE1		
Model	TN-BP4000N1	
Manufacturer	Guangdong Fenghua New Energy Co.,Ltd.	
Capacity	4000mAh	
Nominal Voltage	3.85V	
AE2		
Model	TN-050200U3	
Manufacturer	Guangdong Beicom Electronics Co.,Ltd.	

*AE ID: is used to identify the test sample in the lab internally.

3.4. General Description

The Equipment under Test (EUT) is a model of Smart Phone with integrated antenna and battery. It consists of normal options: Lithium Battery and Charger. Manual and specifications of the EUT were provided to fulfil the test. Samples undergoing test were selected by the client.



4. Reference Documents

4.1. Documents supplied by applicant

EUT parameters, referring to Annex A for detailed information, is supplied by the client or manufacturer, which is the basis of testing.

4.2. Reference Documents for testing

The following documents listed in this section are referred for testing.

Reference	Title	Version
FCC Part15	FCC CFR 47, Part 15, Subpart C: 15.205 Restricted bands of operation; 15.209 Radiated emission limits, general requirements; 15.247 Operation within the bands 902-928MHz, 2400-2483.5 MHz, and 5725-5850 MHz	2019
ANSI C63.10	American National Standard of Procedures for Compliance Testing of Unlicensed Wireless Devices	2013



5. Test Results

5.1. Summary of Test Results

Abbreviations used in this clause:

- P** Pass, The EUT complies with the essential requirements in the standard.
- F** Fail, The EUT does not comply with the essential requirements in the standard
- NA** Not Applicable, The test was not applicable
- NP** Not Performed, The test was not performed by CTTL

SUMMARY OF MEASUREMENT RESULTS	Sub-clause	Verdict
Frequency Band Edges- Radiated	15.247, 15.205, 15.209	P
Transmitter Spurious Emission - Radiated	15.247, 15.205, 15.209	P
AC Powerline Conducted Emission	15.107, 15.207	P

Please refer to **ANNEX A** for detail.

The measurement is made according to ANSI C63.10.

5.2. Statements

CTTL has evaluated the test cases requested by the applicant /manufacturer as listed in section 5.1 of this report for the EUT specified in section 3 according to the standards or reference documents listed in section 4.2

6. Test Equipments Utilized

Conducted test system

No.	Equipment	Model	Serial Number	Manufacturer	Calibration Due Date	Calibration Period
1	Test Receiver	ESCI	100344	R&S	2023-03-21	1 year
2	LISN	ENV216	101200	R&S	2023-06-29	1 year

Test software

No.	Equipment	Manufacturer	Version
1	EMC32	R&S	V10.60.20

Radiated emission test system

No.	Equipment	Model	Serial Number	Manufacturer	Calibration Due Date	Calibration Period
1	Test Receiver	ESW44	103023	R&S	2022-10-28	1 year
2	EMI Antenna	VULB 9163	302	SCHWARZBEC K	2022-12-28	1 year
3	EMI Antenna	3115	00167250	ETS-Lindgren	2022-12-23	1 year

7. Laboratory Environment

Semi-anechoic chamber SAC-1 (10 metersx6.7metersx6.1meters) did not exceed following limits along the EMC testing:

Temperature	Min. = 15 °C, Max. = 35 °C
Relative humidity	Min. = 15 %, Max. = 75 %
Shielding effectiveness	0.014MHz-1MHz, >60dB; 1MHz - 1000MHz, >90dB.
Electrical insulation	> 2 M Ω
Ground system resistance	< 4 Ω
Normalised site attenuation (NSA)	< ± 4 dB, 3m distance
Site voltage standing-wave ratio (S_{VSWR})	Between 0 and 6 dB, from 1GHz to 6GHz
Uniformity of field strength	Between 0 and 6 dB, from 80 to 6000 MHz

Shielded room did not exceed following limits along the EMC testing:

Temperature	Min. = 15 °C, Max. = 35 °C
Relative humidity	Min. = 20 %, Max. = 75 %
Shielding effectiveness	0.014MHz-1MHz, >60dB; 1MHz—1000MHz, >90dB.
Electrical insulation	> 2 M Ω
Ground system resistance	< 4 Ω

8. Measurement Uncertainty

8.1. Frequency Band Edges - Radiated

Measurement Uncertainty:

Measurement Uncertainty (k=2)	/
-------------------------------	---

8.2. Transmitter Spurious Emission - Radiated

Measurement Uncertainty:

Frequency Range	Uncertainty(dBm) (k=2)
9kHz-30MHz	/
$30\text{MHz} \leq f \leq 1\text{GHz}$	5.15
$1\text{GHz} \leq f \leq 18\text{GHz}$	5.54
$18\text{GHz} \leq f \leq 40\text{GHz}$	5.26

8.3. AC Powerline Conducted Emission

Measurement Uncertainty:

Measurement Uncertainty (k=2)	3.08dB
-------------------------------	--------



ANNEX A: Detailed Test Results

A.1. Frequency Band Edges –Radiated

Method of Measurement: See ANSI C63.10-2013-clause 6.4 &6.5 & 6.6

Measurement Limit:

Standard	Limit
FCC 47 CFR Part 15.247, 15.205, 15.209	20dB below peak output power

radiated emissions which fall in the restricted bands, as defined in § 15.205(a), must also comply with the radiated emission limits specified in § 15.209(a) (see § 15.205(c)).

Limit in restricted band:

Frequency (MHz)	Field strength(μ V/m)	Measurement distance (m)
0.009 - 0.490	2400/F(kHz)	300
0.490 - 1.705	24000/F(kHz)	30
1.705 – 30.0	30	30

Frequency of emission (MHz)	Field strength(uV/m)	Field strength(dBuV/m)
30-88	100	40
88-216	150	43.5
216-960	200	46
Above 960	500	54

Set up:

Tabletop devices shall be placed on a nonconducting platform with nominal top surface dimensions 1 m by 1.5 m and the table height shall be 1.5 m.

The EUT and transmitting antenna shall be centered on the turntable.

Test Condition

The EUT shall be tested 1 near top, 1 near middle, and 1 near bottom. Set the unlicensed wireless device to operate in continuous transmit mode. For unlicensed wireless devices unable to be configured for 100% duty cycle even in test mode, configure the system for the maximum duty cycle supported.

When required for unlicensed wireless devices, measurements of the variation of the input power or the radiated signal level of the fundamental frequency component of the emission, as appropriate, shall be performed with the supply voltage varied between 85% and 115% of the nominal rated supply voltage.

Exploratory radiated emissions measurements



Exploratory radiated measurements shall be performed at the measurement distance or at a closer distance than that specified for compliance to determine the emission characteristics of the EUT and, if applicable, the EUT configuration that produces the maximum level of emissions. The frequencies of maximum emission may be determined by manually positioning the antenna close to the EUT, and then moving the antenna over all sides of the EUT while observing a spectral display. It is advantageous to have prior knowledge of the frequencies of emissions, although this may be determined from such a near-field scan. The near-field scan shall only be used to determine the frequency but not the amplitude of the emissions. Where exploratory measurements are not adequate to determine the worst-case operating modes and are used only to identify the frequencies of the highest emissions, additional preliminary tests can be required.

For emissions from the EUT, the maximum level shall be determined by rotating the EUT and its antenna through 0° to 360°. For each mode of operation required to be tested, the frequency spectrum (based on findings from exploratory measurements) shall be monitored.

Broadband antennas and a spectrum analyzer or a radio-noise meter with a panoramic display are often useful in this type of test. If either antenna height or EUT azimuth are not fully measured during exploratory testing, then complete testing can be required at the OATS or semi-anechoic chamber when the final full spectrum testing is performed.

Final radiated emissions measurements

The final measurements are using the orientation and equipment arrangement of the EUT based on the measurement results found during the preliminary (exploratory) measurements, the EUT arrangement, appropriate modulation, and modes of operation that produce the emissions that have the highest amplitude relative to the limit shall be selected for the final measurement.

For emissions from the EUT, the maximum level shall be determined by rotating the EUT and its antenna through 0° to 360°. Final measurements for the EUT require a measurement antenna height scan of 1 m to 4 m and the antenna rotated to repeat the measurements for both the horizontal and vertical antenna polarizations. For each mode of operation required to be tested, the frequency spectrum (based on findings from exploratory measurements) shall be monitored.

For each mode selected, record the frequency and amplitude of the highest fundamental emission (if applicable), as well as the frequency and amplitude of the six highest spurious emissions relative to the limit. Emissions more than 20 dB below the limit do not need to be reported.

This maximization process was repeated with the EUT positioned in each of its three orthogonal orientations.

The receiver references:

Frequency of emission (MHz)	RBW/VBW	Sweep Time(s)
30-1000	100kHz/300kHz	5
1000-4000	1MHz/3MHz	15
4000-18000	1MHz/3MHz	40
18000-26500	1MHz/3MHz	20

EUT ID: UT41a

Measurement Results:

Mode	Channel	Frequency Range	Test Results	Conclusion
GFSK	0	2.31GHz ~2.43GHz	Fig.33	P
	39	2.45GHz ~2.5GHz	Fig.34	P

Conclusion: PASS

Test graphs as below

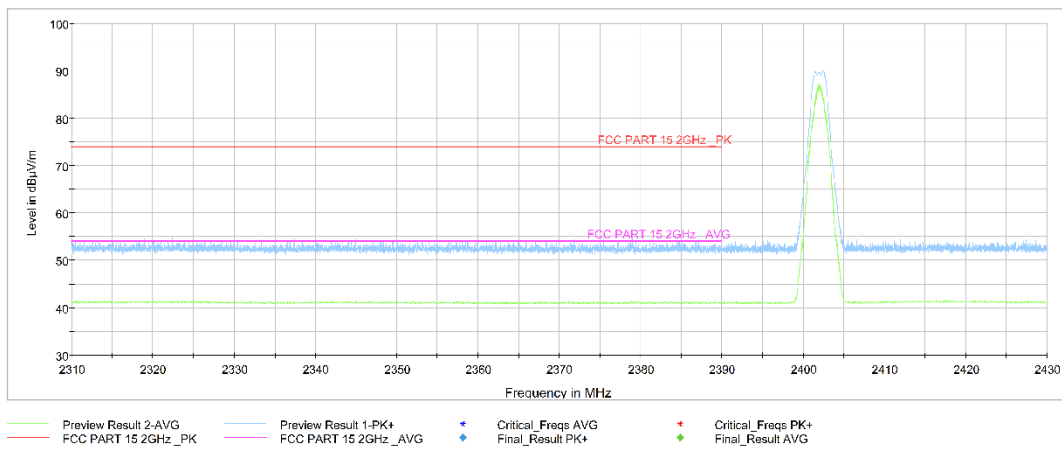

Fig.1 Frequency Band Edges: GFSK, 2402 MHz, LE 2M, 2.31 GHz – 2.43GHz

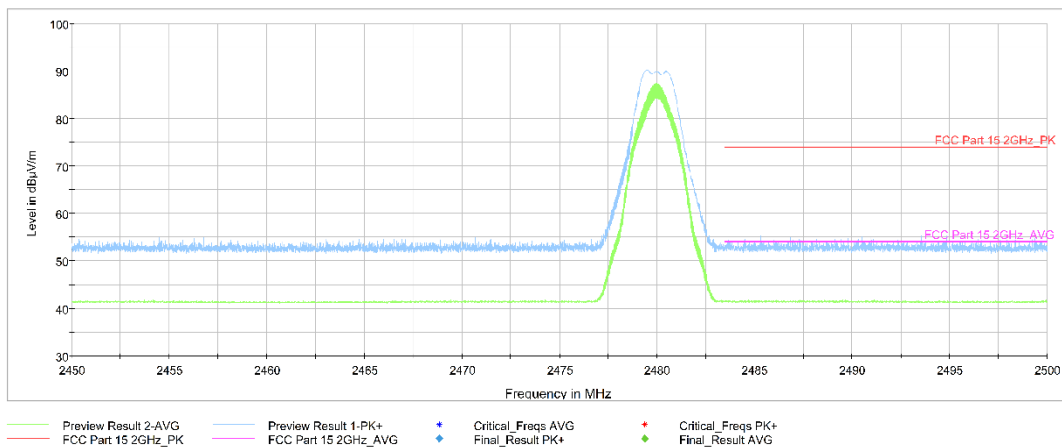

Fig.2 Frequency Band Edges: GFSK, 2480 MHz, LE 2M, 2.45 GHz - 2.50GHz

A.2. Transmitter Spurious Emission - Radiated

Method of Measurement: See ANSI C63.10-2013-clause 6.4 & 6.5 & 6.6

Measurement Limit:

Standard	Limit
FCC 47 CFR Part 15.247, 15.205, 15.209	20dB below peak output power

radiated emissions which fall in the restricted bands, as defined in § 15.205(a), must also comply with the radiated emission limits specified in § 15.209(a) (see § 15.205(c)).

Limit in restricted band:

Frequency (MHz)	Field strength($\mu\text{V}/\text{m}$)	Measurement distance (m)
0.009 - 0.490	$2400/F(\text{kHz})$	300
0.490 - 1.705	$24000/F(\text{kHz})$	30
1.705 – 30.0	30	30

Frequency of emission (MHz)	Field strength($\mu\text{V}/\text{m}$)	Field strength(dBuV/m)
30-88	100	40
88-216	150	43.5
216-960	200	46
Above 960	500	54

Set up:

Tabletop devices shall be placed on a nonconducting platform with nominal top surface dimensions 1 m by 1.5 m. For emissions testing at or below 1 GHz, the table height shall be 80 cm above the reference ground plane. For emission measurements above 1 GHz, the table height shall be 1.5 m

The EUT and transmitting antenna shall be centered on the turntable.

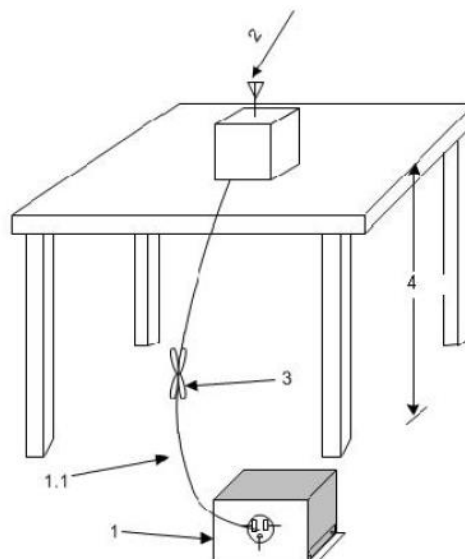

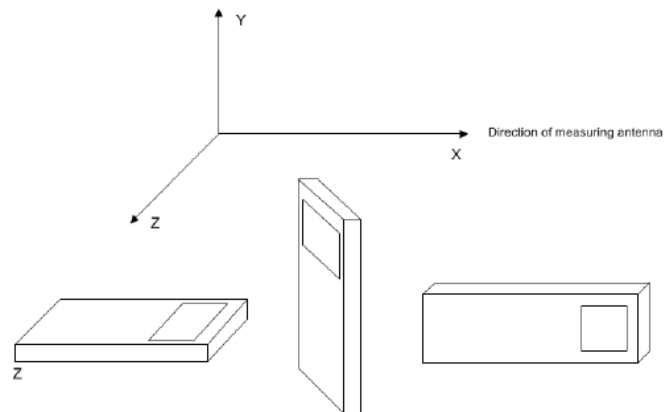

Test Condition

The EUT shall be tested 1 near top, 1 near middle, and 1 near bottom. Set the unlicensed wireless device to operate in continuous transmit mode. For unlicensed wireless devices unable to be configured for 100% duty cycle even in test mode, configure the system for the maximum duty cycle supported.

When required for unlicensed wireless devices, measurements of the variation of the input power or the radiated signal level of the fundamental frequency component of the emission, as appropriate, shall be performed with the supply voltage varied between 85% and 115% of the nominal rated supply voltage.

Exploratory radiated emissions measurements

Exploratory radiated measurements shall be performed at the measurement distance or at a closer distance than that specified for compliance to determine the emission characteristics of the EUT and, if applicable, the EUT configuration that produces the maximum level of emissions. The frequencies of maximum emission may be determined by manually positioning the antenna close to the EUT, and then moving the antenna over all sides of the EUT while observing a spectral display. It is advantageous to have prior knowledge of the frequencies of emissions, although this may be determined from such a near-field scan. The near-field scan shall only be used to determine the frequency but not the amplitude of the emissions. Where exploratory measurements are not adequate to determine the worst-case operating modes and are used only to identify the frequencies of the highest emissions, additional preliminary tests can be required.

For emissions from the EUT, the maximum level shall be determined by rotating the EUT and its antenna through 0° to 360° . For each mode of operation required to be tested, the frequency spectrum (based on findings from exploratory measurements) shall be monitored.

Broadband antennas and a spectrum analyzer or a radio-noise meter with a panoramic display are often useful in this type of test. If either antenna height or EUT azimuth are not fully measured during exploratory testing, then complete testing can be required at the OATS or semi-anechoic chamber when the final full spectrum testing is performed.

Final radiated emissions measurements

The final measurements are using the orientation and equipment arrangement of the EUT based on the measurement results found during the preliminary (exploratory) measurements, the EUT



arrangement, appropriate modulation, and modes of operation that produce the emissions that have the highest amplitude relative to the limit shall be selected for the final measurement. For each mode of operation required to be tested, the frequency spectrum (based on findings from exploratory measurements) shall be monitored. The highest signal levels relative to the limit shall be determined by rotating the EUT from 0° to 360° and with varying the measurement antenna height between 1 m and 4 m in vertical and horizontal polarizations. For each mode selected, record the frequency and amplitude of the highest fundamental emission (if applicable), as well as the frequency and amplitude of the six highest spurious emissions relative to the limit. Emissions more than 20 dB below the limit do not need to be reported. This maximization process was repeated with the EUT positioned in each of its three orthogonal orientations.

The receiver references:

Frequency of emission (MHz)	RBW/VBW	Sweep Time(s)
30-1000	100kHz/300kHz	5
1000-4000	1MHz/3MHz	15
4000-18000	1MHz/3MHz	40
18000-26500	1MHz/3MHz	20

P_{Mea} is the field strength recorded from the instrument.

The measurement results are obtained as described below:

Result= P_{Mea} + Cable Loss + Antenna Factor

Where:

P_{Mea} field strength recorded from the instrument

Average Measurement results
GFSK 2402MHz

Frequency (MHz)	Measurement Result (dBuV/m)	Cable Loss (dB)	Antenna Factor (dB/m)	Receiver Reading (dBuV)	Limit (dBuV/m)	Margin (dB)	Antenna Pol. (H/V)
17991.500	40.96	-25.50	46.70	19.76	54.00	13.04	H
13685.000	39.05	-29.50	40.40	28.15	54.00	14.95	V
12767.500	36.92	-30.50	39.10	28.32	54.00	17.08	V
9492.000	35.32	-33.20	37.90	30.62	54.00	18.68	V
7319.000	34.84	-35.10	36.60	33.34	54.00	19.16	V
2325.000	41.49	-20.10	27.90	33.59	54.00	12.51	H

GFSK 2440MHz

Frequency (MHz)	Measurement Result (dBuV/m)	Cable Loss (dB)	Antenna Factor (dB/m)	Receiver Reading (dBuV)	Limit (dBuV/m)	Margin (dB)	Antenna Pol. (H/V)
17972.500	41.21	-25.50	46.70	20.01	54.00	12.79	V
14092.500	39.04	-29.40	41.70	26.84	54.00	14.96	V
12993.000	36.94	-30.50	39.20	28.24	54.00	17.06	V
9630.500	35.31	-33.10	38.00	30.41	54.00	18.69	V
7314.500	34.81	-35.00	36.50	33.21	54.00	19.19	H
4774.000	30.05	-37.30	33.00	34.25	54.00	23.95	V

GFSK 2480MHz

Frequency (MHz)	Measurement Result (dBuV/m)	Cable Loss (dB)	Antenna Factor (dB/m)	Receiver Reading (dBuV)	Limit (dBuV/m)	Margin (dB)	Antenna Pol. (H/V)
17971.000	41.16	-25.50	46.70	19.96	54.00	12.84	H
14101.000	39.22	-29.40	41.70	27.02	54.00	14.78	H
12770.000	37.14	-30.50	39.10	28.54	54.00	16.86	H
9481.500	35.59	-33.20	37.90	30.89	54.00	18.41	V
7318.000	35.41	-35.10	36.60	33.91	54.00	18.59	V
2488.600	41.82	-20.00	28.30	33.52	54.00	12.18	V

Peak Measurement results
GFSK 2402MHz

Frequency (MHz)	Measurement Result (dBuV/m)	Cable Loss (dB)	Antenna Factor (dB/m)	Receiver Reading (dBuV)	Limit (dBuV/m)	Margin (dB)	Antenna Pol. (H/V)
17559.500	52.93	-26.90	45.20	34.53	74.00	21.07	V
13732.000	50.62	-29.10	40.90	38.82	74.00	23.38	H
11925.500	48.90	-31.50	39.10	41.30	74.00	25.10	H
9042.500	47.01	-33.80	38.10	42.61	74.00	26.99	V
7320.000	46.29	-35.10	36.60	44.79	74.00	27.71	V
2379.000	54.95	-20.00	28.10	46.95	74.00	19.05	H

GFSK 2440MHz

Frequency (MHz)	Measurement Result (dBuV/m)	Cable Loss (dB)	Antenna Factor (dB/m)	Receiver Reading (dBuV)	Limit (dBuV/m)	Margin (dB)	Antenna Pol. (H/V)
17450.500	52.48	-26.90	45.20	34.08	74.00	21.52	H
14108.000	50.81	-29.40	41.70	38.61	74.00	23.19	H
12849.500	48.80	-30.70	39.10	40.30	74.00	25.20	V
8013.000	47.00	-34.70	37.20	44.50	74.00	27.00	V
7486.000	46.76	-34.50	36.80	44.46	74.00	27.24	V
4953.000	41.21	-37.10	33.30	45.01	74.00	32.79	V

GFSK 2480MHz

Frequency (MHz)	Measurement Result (dBuV/m)	Cable Loss (dB)	Antenna Factor (dB/m)	Receiver Reading (dBuV)	Limit (dBuV/m)	Margin (dB)	Antenna Pol. (H/V)
17445.000	53.15	-26.90	45.20	34.75	74.00	20.85	H
14561.500	50.33	-27.30	41.90	35.73	74.00	23.67	H
12296.000	48.46	-31.10	38.90	40.66	74.00	25.54	H
7317.500	46.88	-35.10	36.60	45.38	74.00	27.12	H
9375.500	46.75	-33.90	38.00	42.65	74.00	27.25	H
2493.600	55.34	-20.00	28.30	47.04	74.00	18.66	V

Conclusion: PASS

A.3. AC Powerline Conducted Emission

Method of Measurement: See ANSI C63.10-clause 6.2

Setup:

A stand-alone EUT shall be placed in the center along the back edge of the tabletop. For multiunit tabletop systems, the EUT shall be centered laterally (left to right facing the tabletop) on the tabletop and its rear shall be flush with the rear of the table.

Accessories that are part of an EUT system tested on a tabletop shall be placed in a test arrangement on one or both sides of the host with a 10 cm separation between the nearest points of the cabinets. The rear of the host and accessories shall be flush with the back of the supporting tabletop unless that would not be typical of normal use. If more than two accessories are present, then an equipment test arrangement shall be chosen that maintains 10 cm spacing between cabinets unless the equipment is normally located closer together.

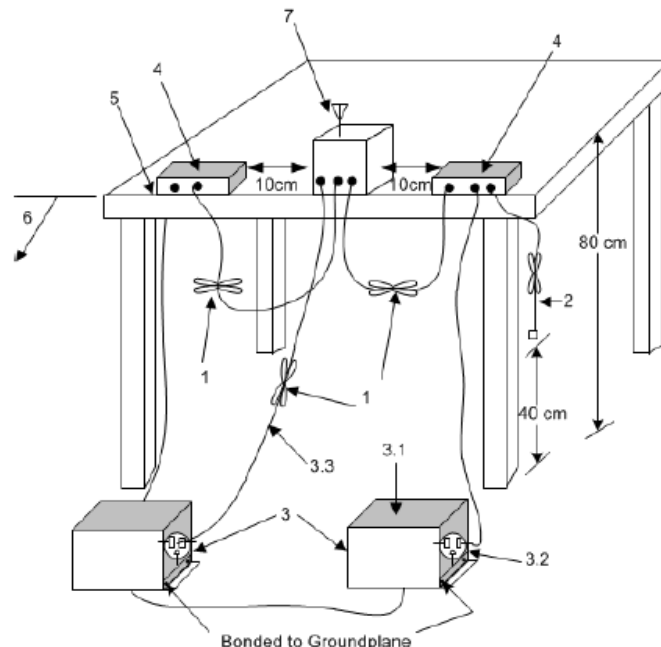

Exploratory ac power-line conducted emission measurements

Exploratory measurements shall be used to identify the frequency of the emission that has the highest amplitude relative to the limit by operating the EUT in a range of typical modes of operation, cable positions, and with a typical system equipment configuration and arrangement. For each mode of operation and for each ac power current-carrying conductor, cable manipulation shall be performed within the range of likely configurations. For this measurement or series of measurements, the frequency spectrum of interest shall be monitored looking for the emission that has the highest amplitude relative to the limit. Once that emission is found for each current-carrying conductor of each power cord associated with the EUT (but not the cords associated with non-EUT equipment in the overall system), the one configuration and arrangement and mode of operation that produces the emission closest to the limit over all of the measured conductors shall be recorded.

Final ac power-line conducted emission measurements

Based on the exploratory tests of the EUT, the one EUT cable configuration and arrangement and mode of operation that produced the emission with the highest amplitude relative to the limit is

selected for the final measurement, while applying the appropriate modulating signal to the EUT. If the EUT is relocated from an exploratory test site to a final test site, the highest emissions shall be remaximized at the final test location before final ac power-line conducted emission measurements are performed. The final test on all current-carrying conductors of all of the power cords to the equipment that comprises the EUT (but not the cords associated with other non-EUT equipment in the system) is then performed for the full frequency range for which the EUT is being tested for compliance without further variation of the EUT arrangement, cable positions, or EUT mode of operation. If the EUT is composed of equipment units that have their own separate ac power connections (e.g., floor-standing equipment with independent power cords for each shelf that are able to connect directly to the ac power network), then each current-carrying conductor of one unit is measured while the other units are connected to a second (or more) LISN(s). All units shall be measured separately. If a power strip is provided by the manufacturer, to supply all of the units making up the EUT, only the conductors in the power cord of the power strip shall be measured.

Test Condition:

Voltage (V)	Frequency (Hz)
120	60

Measurement Result and limit:

EUT ID: EUT1

Bluetooth (Quasi-peak Limit)

Frequency range (MHz)	Quasi-peak Limit (dB μ V)	Result (dB μ V)		Conclusion
		With charger		
		bluetooth	Idle	
0.15 to 0.5	66 to 56	Fig.35	Fig.36	P
0.5 to 5	56			
5 to 30	60			

NOTE: The limit decreases linearly with the logarithm of the frequency in the range 0.15 MHz to 0.5 MHz.

Bluetooth (Average Limit)

Frequency range (MHz)	Average Limit (dB μ V)	Result (dB μ V)		Conclusion
		With charger		
		bluetooth	Idle	
0.15 to 0.5	56 to 46	Fig.35	Fig.36	P
0.5 to 5	46			
5 to 30	50			

NOTE: The limit decreases linearly with the logarithm of the frequency in the range 0.15 MHz to 0.5 MHz.

Conclusion: Pass

Test graphs as below:

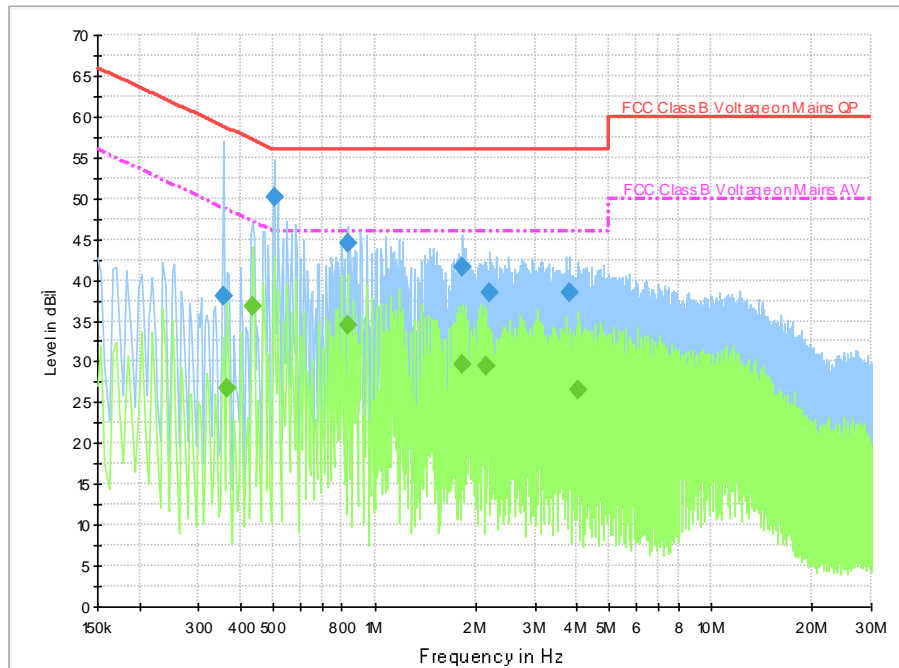

Fig.3 AC Powerline Conducted Emission- bluetooth

Note: The graphic result above is the maximum of the measurements for both phase line and neutral line.

Final Result 1

Frequency (MHz)	QuasiPeak (dBuV)	Meas. Time (ms)	Bandwidth (kHz)	Filter	Line	Corr. (dB)	Margin (dB)	Limit (dBuV)	Comment
0.354000	38.0	5000.0	9.000	On	L1	19.7	20.9	58.9	
0.502000	50.1	5000.0	9.000	On	L1	19.7	5.9	56.0	
0.830000	44.5	5000.0	9.000	On	L1	19.7	11.5	56.0	
1.822000	41.6	5000.0	9.000	On	L1	19.6	14.4	56.0	
2.194000	38.4	5000.0	9.000	On	L1	19.6	17.6	56.0	
3.790000	38.5	5000.0	9.000	On	L1	19.6	17.5	56.0	

Final Result 2

Frequency (MHz)	QuasiPeak (dBuV)	Meas. Time (ms)	Bandwidth (kHz)	Filter	Line	Corr. (dB)	Margin (dB)	Limit (dBuV)	Comment
0.366000	26.7	5000.0	9.000	On	L1	19.7	21.9	48.6	
0.434000	36.7	5000.0	9.000	On	L1	19.7	10.4	47.2	
0.830000	34.4	5000.0	9.000	On	L1	19.7	11.6	46.0	
1.822000	29.7	5000.0	9.000	On	L1	19.6	16.3	46.0	
2.134000	29.6	5000.0	9.000	On	L1	19.6	16.4	46.0	
4.022000	26.5	5000.0	9.000	On	L1	19.6	19.5	46.0	

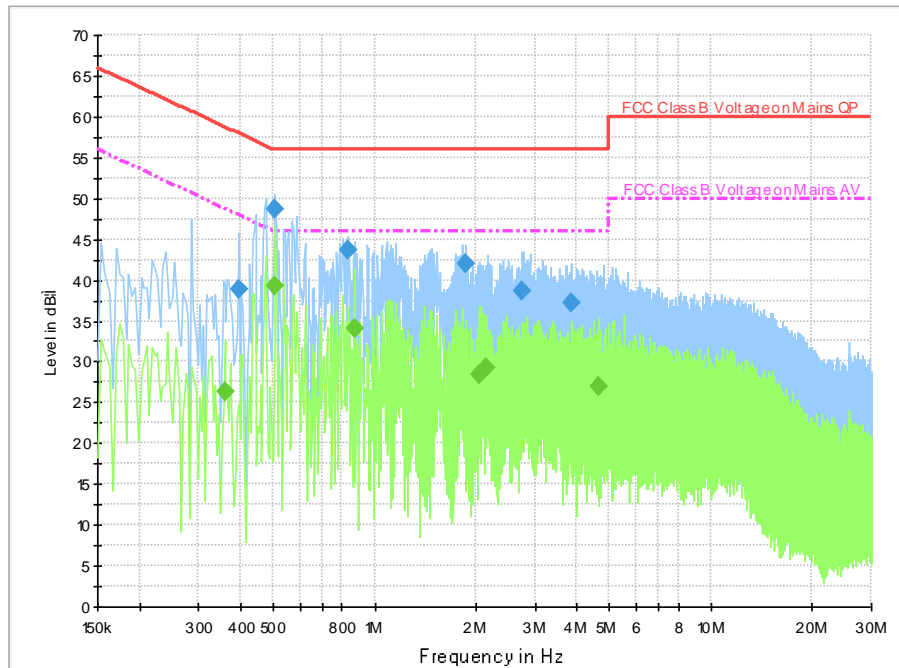

Fig.4 AC Powerline Conducted Emission-Idle

Note: The graphic result above is the maximum of the measurements for both phase line and neutral line.

Final Result 1

Frequency (MHz)	QuasiPeak (dBuV)	Meas. Time (ms)	Bandwidth (kHz)	Filter	Line	Corr. (dB)	Margin (dB)	Limit (dBuV)	Comment
0.394000	38.8	5000.0	9.000	On	L1	19.7	19.2	58.0	
0.506000	48.6	5000.0	9.000	On	L1	19.7	7.4	56.0	
0.834000	43.7	5000.0	9.000	On	L1	19.7	12.3	56.0	
1.858000	42.0	5000.0	9.000	On	L1	19.6	14.0	56.0	
2.758000	38.7	5000.0	9.000	On	L1	19.6	17.3	56.0	
3.846000	37.2	5000.0	9.000	On	L1	19.6	18.8	56.0	

Final Result 2

Frequency (MHz)	QuasiPeak (dBuV)	Meas. Time (ms)	Bandwidth (kHz)	Filter	Line	Corr. (dB)	Margin (dB)	Limit (dBuV)	Comment
0.358000	26.4	5000.0	9.000	On	L1	19.7	22.4	48.8	
0.506000	39.3	5000.0	9.000	On	L1	19.7	6.7	46.0	
0.870000	34.0	5000.0	9.000	On	L1	19.6	12.0	46.0	
2.046000	28.4	5000.0	9.000	On	L1	19.6	17.6	46.0	
2.134000	29.3	5000.0	9.000	On	L1	19.6	16.7	46.0	
4.662000	26.9	5000.0	9.000	On	L1	19.6	19.1	46.0	

END OF REPORT