

FCC Test Report

FCC ID : YHICE-IMX6-01
Equipment : WLAN/BT Module
Brand Name : NEXCOM
Model Name : WG7833-B0
Applicant : NEXCOM International Co., LTD.
9F., No.920, Chung-Cheng Road, Zhonghe Dist.,
New Taipei City, Taiwan 235, R.O.C.
Manufacturer : NEXCOM International Co., LTD.
9F., No.920, Chung-Cheng Road, Zhonghe Dist.,
New Taipei City, Taiwan 235, R.O.C.
Standard : 47 CFR FCC Part 15.247

The product was received on Feb. 09, 2018, and testing was started from Mar. 08, 2018 and completed on Mar. 17, 2018. We, SPORTON INTERNATIONAL INC. EMC & Wireless Communications Laboratory, would like to declare that the tested sample has been evaluated in accordance with the procedures given in ANSI C63.10-2013 and shown compliance with the applicable technical standards.

The report must not be used by the client to claim product certification, approval, or endorsement by TAF or any agency of government.

The test results in this report apply exclusively to the tested model / sample. Without written approval of SPORTON INTERNATIONAL INC. EMC & Wireless Communications Laboratory, the test report shall not be reproduced except in full.



Approved by: Allen Lin

SPORTON INTERNATIONAL INC. EMC & Wireless Communications Laboratory

No. 52, Huaya 1st Rd., Guishan Dist., Taoyuan City, Taiwan (R.O.C.)



Table of Contents

HISTORY OF THIS TEST REPORT3

SUMMARY OF TEST RESULT4

1 GENERAL DESCRIPTION5

1.1 Information.....5

1.2 Testing Applied Standards7

1.3 Testing Location Information7

1.4 Measurement Uncertainty7

2 TEST CONFIGURATION OF EUT.....8

2.1 Test Condition8

2.2 Test Channel Mode8

2.3 The Worst Case Measurement Configuration.....9

2.4 Support Equipment.....10

2.5 Test Setup Diagram11

3 TRANSMITTER TEST RESULT13

3.1 AC Power-line Conducted Emissions13

3.2 20dB Bandwidth and Carrier Frequency Separation.....14

3.3 Maximum Conducted Output Power15

3.4 Number of Hopping Frequencies and Hopping Bandedge16

3.5 Time of Occupancy (Dwell Time)17

3.6 Emissions in Non-restricted Frequency Bands18

3.7 Emissions in Restricted Frequency Bands.....19

4 TEST EQUIPMENT AND CALIBRATION DATA.....22

APPENDIX A. TEST RESULTS OF AC POWER-LINE CONDUCTED EMISSIONS

APPENDIX B. TEST RESULTS OF 20DB BANDWIDTH AND CARRIER FREQUENCY SEPARATION

APPENDIX C. TEST RESULTS OF MAXIMUM CONDUCTED OUTPUT POWER

APPENDIX D. TEST RESULTS OF NUMBER OF HOPPING FREQUENCIES AND HOPPING BANDEDGE

APPENDIX E. TEST RESULTS OF TIME OF OCCUPANCY (DWELL TIME)

APPENDIX F. TEST RESULTS OF EMISSIONS IN NON-RESTRICTED FREQUENCY BANDS

APPENDIX G. TEST RESULTS OF EMISSIONS IN RESTRICTED FREQUENCY BANDS

APPENDIX H. TEST PHOTOS

PHOTOGRAPHS OF EUT V01



History of this test report

Report No.	Version	Description	Issued Date
FR820209AD	01	Initial issue of report	Mar. 30, 2018



Summary of Test Result

Report Clause	Ref. Std. Clause	Test Items	Result (PASS/FAIL)	Remark
1.1.2	15.203	Antenna Requirement	PASS	FCC 15.203
3.1	15.207	AC Power-line Conducted Emissions	PASS	FCC 15.207
3.2	15.247(a)	20dB Bandwidth	PASS	15.247(a)
3.2	15.247(a)	Carrier Frequency Separation	PASS	15.247(a)
3.3	15.247(b)	Maximum Conducted Output Power	PASS	15.247(b)
3.4	15.247(a)	Number of Hopping Frequencies and Hopping Bandedge	PASS	15.247(a)
3.5	15.247(a)	Time of Occupancy (Dwell Time)	PASS	15.247(a)
3.6	15.247(d)	Emissions in Non-restricted Frequency Bands	PASS	15.247(d)
3.7	15.247(d)	Emissions in Restricted Frequency Bands	PASS	Restricted Bands: FCC 15.209

Reviewed by: Sam Tsai

Report Producer: Michelle Tsai

1 General Description

1.1 Information

1.1.1 RF General Information

Frequency Range (MHz)	Bluetooth Version	Ch. Frequency (MHz)	Channel Number
2400-2483.5	BR / EDR	2402-2480	0-78 [79]

Band	Mode	BWch (MHz)	Nant
2.4-2.4835GHz	BT-BR(1Mbps)	1	1TX
2.4-2.4835GHz	BT-EDR(2Mbps)	1	1TX
2.4-2.4835GHz	BT-EDR(3Mbps)	1	1TX

Note:

- ◆ Bluetooth BR uses a GFSK (1Mbps).
- ◆ Bluetooth EDR uses a combination of $\pi/4$ -DQPSK (2Mbps) and 8DPSK (3Mbps).
- ◆ Bluetooth BR/EDR uses as a system using FHSS modulation.
- ◆ BWch is the nominal channel bandwidth.

1.1.2 Antenna Information

Ant.	Port	Brand	Model Name	Antenna Type	Connector
1	1	SMARTEQ WIRELESS	LPCA-MINO	OMNI Antenna	I-PEX

Ant.	Gain (dBi)	
	2.4G	BT
1	2.15	2.15

Note: The antenna mentioned above will not be sold with the EUT in the market.



1.1.3 EUT Information

Operational Condition	
EUT Power Type	From Host system
RF Chip	WG7833-B0
Type of EUT	
<input checked="" type="checkbox"/>	Stand-alone
<input type="checkbox"/>	Combined (EUT where the radio part is fully integrated within another device)
	Combined Equipment - Brand Name / Model No.: ...
<input type="checkbox"/>	Plug-in radio (EUT intended for a variety of host systems)
	Host System - Brand Name / Model No.: ...
<input type="checkbox"/>	Other:

1.1.4 Mode Test Duty Cycle

Mode	DC	DCF(dB)	T(s)	VBW(Hz) ≥ 1/T
BT-BR(1Mbps)	0.782	1.068	2.913m	1k
BT-EDR(2Mbps)	0.774	1.113	2.913m	1k
BT-EDR(3Mbps)	0.781	1.073	2.916m	1k

1.2 Testing Applied Standards

According to the specifications of the manufacturer, the EUT must comply with the requirements of the following standards:

- ◆ 47 CFR FCC Part 15
- ◆ Public Notice DA 00-705
- ◆ ANSI C63.10-2013

1.3 Testing Location Information

Testing Location			
<input checked="" type="checkbox"/>	HWA YA	ADD : No. 52, Huaya 1st Rd., Guishan Dist., Taoyuan City, Taiwan (R.O.C.)	
		TEL : 886-3-327-3456	FAX : 886-3-327-0973
Test site Designation No. TW1190 with FCC.			
<input type="checkbox"/>	JHUBEI	ADD : No.8, Ln. 724, Bo'ai St., Zhubei City, Hsinchu County, Taiwan (R.O.C.)	
		TEL : 886-3-656-9065	FAX : 886-3-656-9085
Test site Designation No. TW0006 with FCC.			

Test Condition	Test Site No.	Test Engineer	Test Environment	Test Date
RF Conducted	TH01-HY	Randy	22.5°C / 62%	08/Mar/2018
Radiated	03CH03-HY	Jerry	22.2°C / 51.8%	13/Mar/2018
AC Conduction	CO04-HY	Daniel	21.6°C / 52.8%	17/Mar/2018

1.4 Measurement Uncertainty

ISO/IEC 17025 requires that an estimate of the measurement uncertainties associated with the emissions test results be included in the report. The measurement uncertainties given below are based on a 95% confidence level (based on a coverage factor (k=2))

Test Items	Uncertainty	Remark
Conducted Emission (150kHz ~ 30MHz)	3.6 dB	Confidence levels of 95%
Radiated Emission (9kHz ~ 30MHz)	3.0 dB	Confidence levels of 95%
Radiated Emission (30MHz ~ 1,000MHz)	4.3 dB	Confidence levels of 95%
Radiated Emission (1GHz ~ 18GHz)	3.9 dB	Confidence levels of 95%
Radiated Emission (18GHz ~ 40GHz)	3.5 dB	Confidence levels of 95%
Conducted Emission	1.3 dB	Confidence levels of 95%
Temperature	0.7 °C	Confidence levels of 95%
Humidity	4 %	Confidence levels of 95%

2 Test Configuration of EUT

2.1 Test Condition

RF Conducted	Abbreviation	Remark
RF Conducted-FS	Abbreviation	Remark
TnomVnom	Tnom	20°C
-	Vnom	120V

2.2 Test Channel Mode

Mode	Power Setting
BT-BR(1Mbps)	-
2402MHz	7
2441MHz	7
2480MHz	7
BT-EDR(2Mbps)	-
2402MHz	7
2441MHz	7
2480MHz	7
BT-EDR(3Mbps)	-
2402MHz	7
2441MHz	7
2480MHz	7

2.3 The Worst Case Measurement Configuration

The Worst Case Mode for Following Conformance Tests	
Tests Item	AC power-line conducted emissions
Condition	AC power-line conducted measurement for line and neutral
Operating Mode	CTX
1	USB Mode ; BT 2.1+EDR TX

The Worst Case Mode for Following Conformance Tests	
Tests Item	20dB Bandwidth Carrier Frequency Separation Maximum Conducted Output Power Number of Hopping Frequencies Hopping Bandedge Time of Occupancy (Dwell Time) Emissions in Non-restricted Frequency Bands
Test Condition	Conducted measurement at transmit chains

The Worst Case Mode for Following Conformance Tests	
Tests Item	Emissions in Restricted Frequency Bands
Test Condition	Radiated measurement If EUT consist of multiple antenna assembly (multiple antenna are used in EUT regardless of spatial multiplexing MIMO configuration), the radiated test should be performed with highest antenna gain of each antenna type.
Operating Mode < 1GHz	CTX
1	USB Mode
Operating Mode > 1GHz	CTX
Orthogonal Planes of EUT	Z Plane
	



2.4 Support Equipment

Support Equipment – RF Conducted				
No.	Equipment	Brand Name	Model Name	FCC ID
1	Notebook	DELL	E5410	R33002 / DoC
2	AC Adapter for Notebook	DELL	HA65NM130	R35737 / DoC
3	Fixture	-	-	-

Note: Support equipment No.3 was provided by customer.

Support Equipment – Radiated Emission				
No.	Equipment	Brand Name	Model Name	FCC ID
1	Notebook	DELL	E5530	R33002
2	AC Adapter for Notebook	DELL	LA65NS2-01	DoC
3	Fixture	-	-	-
4	Antenna	SMARTEQ WIRELESS	LPCA-MINO	-

Note: Support equipment No.3 was provided by customer.

Support Equipment – AC Conduction				
No.	Equipment	Brand Name	Model Name	FCC ID
1	Notebook	DELL	E5530	R33002
2	AC Adapter for Notebook	DELL	LA65NS2-01	DoC
3	Fixture	-	-	-
4	Antenna	SMARTEQ WIRELESS	LPCA-MINO	-

Note: Support equipment No.3 was provided by customer.

2.5 Test Setup Diagram

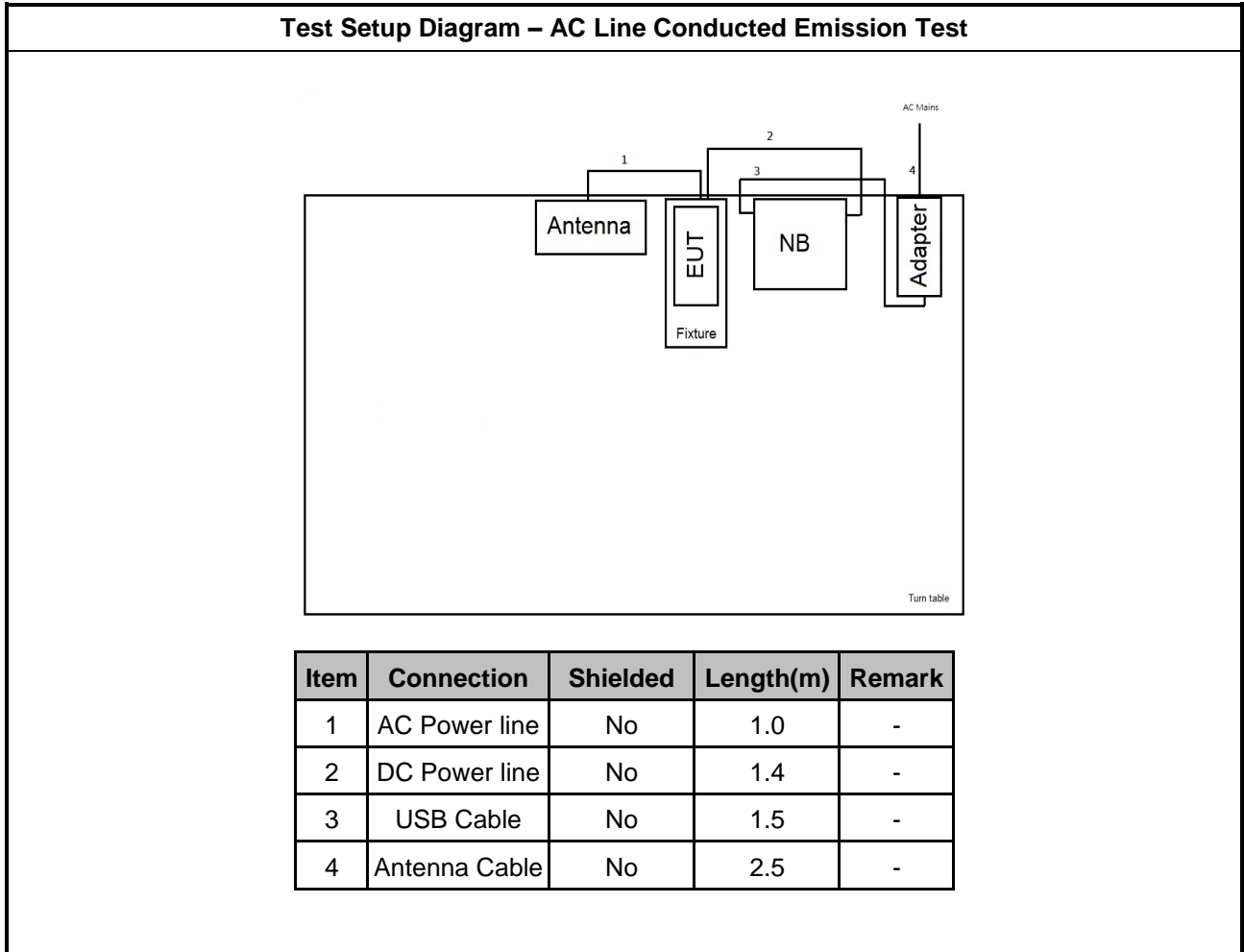

Test Setup Diagram - Radiated Test

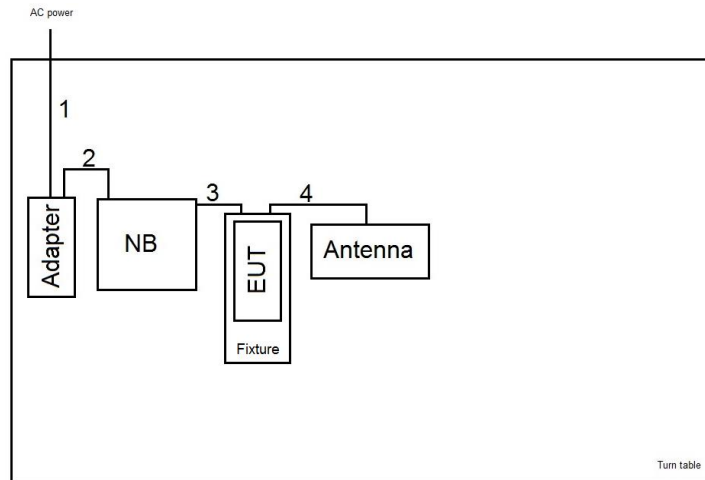

Item	Connection	Shielded	Length(m)	Remark
1	AC Power line	No	1.0	-
2	DC Power line	No	1.4	-
3	USB Cable	No	1.5	-
4	Antenna Cable	No	2.5	-

3 Transmitter Test Result

3.1 AC Power-line Conducted Emissions

3.1.1 AC Power-line Conducted Emissions Limit

AC Power-line Conducted Emissions Limit		
Frequency Emission (MHz)	Quasi-Peak	Average
0.15-0.5	66 - 56 *	56 - 46 *
0.5-5	56	46
5-30	60	50

Note 1: * Decreases with the logarithm of the frequency.

3.1.2 Measuring Instruments

Refer a test equipment and calibration data table in this test report.

3.1.3 Test Procedures

Test Method
<ul style="list-style-type: none"> Refer as ANSI C63.10-2013, clause 6.2 foray power-line conducted emissions.

3.1.4 Test Setup

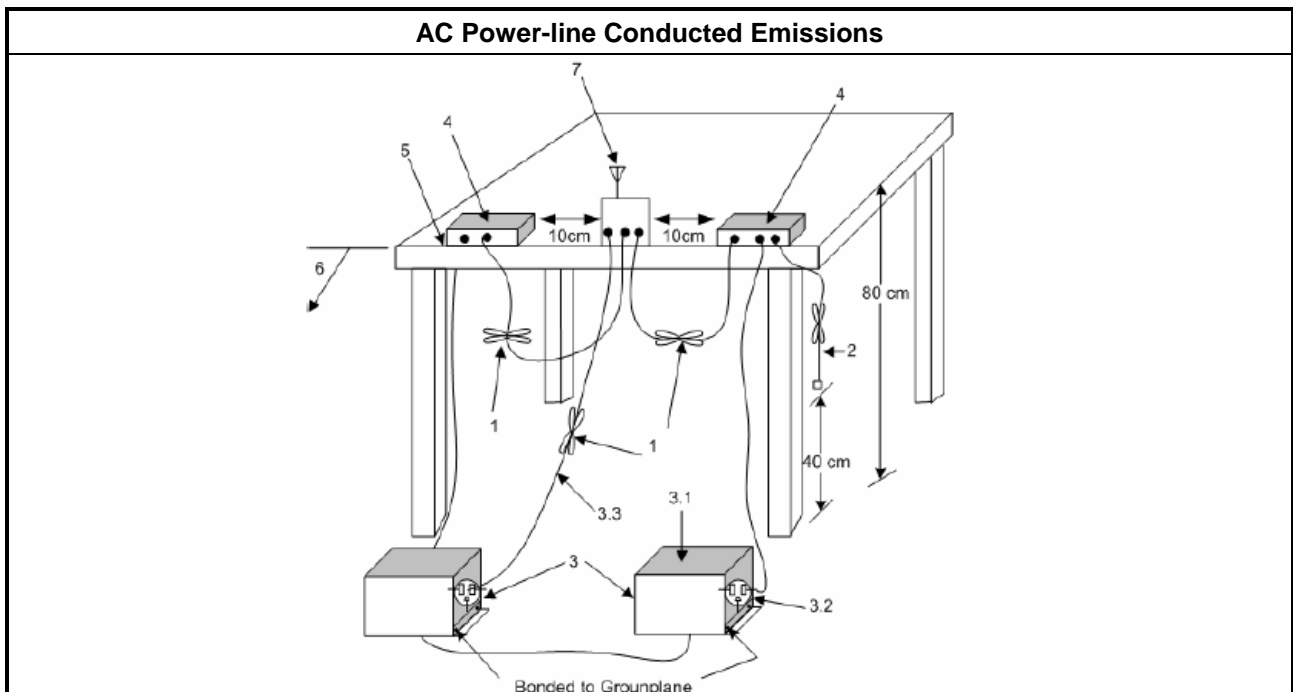

3.1.5 Test Result of AC Power-line Conducted Emissions

Refer as Appendix A

3.2 20dB Bandwidth and Carrier Frequency Separation

3.2.1 20dB Bandwidth and Carrier Frequency Separation Limit

20dB Bandwidth and Carrier Frequency Separation Limit for Frequency Hopping Systems	
<ul style="list-style-type: none"> ▪ 2400-2483.5 MHz Band: 	
	<ul style="list-style-type: none"> ▪ $N \geq 75$ and $ChS \geq MAX$ (20 dB bandwidth, 25 kHz).
	<ul style="list-style-type: none"> ▪ $75 > N \geq 15$ and $ChS \geq MAX$ (20 dB bandwidth 2/3,25 kHz).
N: Number of Hopping Frequencies; ChS: Hopping Channel Separation	

3.2.2 Measuring Instruments

Refer a test equipment and calibration data table in this test report.

3.2.3 Test Procedures

Test Method
<ul style="list-style-type: none"> ▪ Refer as ANSI C63.10-2013, clause 6.9.2 for 20 dB bandwidth measurement.
<ul style="list-style-type: none"> ▪ Refer as ANSI C63.10-2013, clause 7.8.2 for carrier frequency separation measurement.

3.2.4 Test Setup

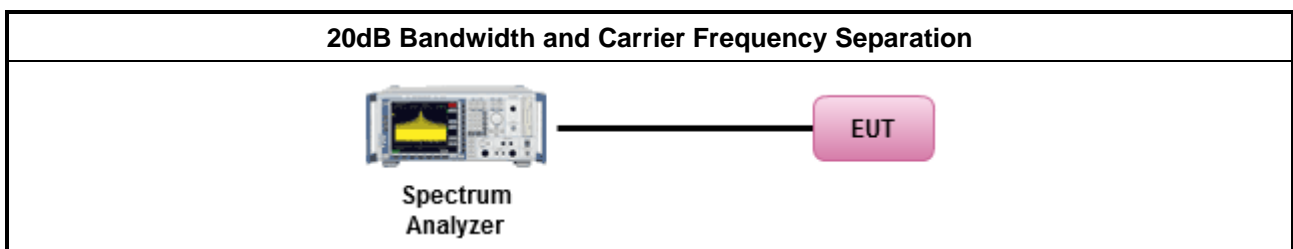

3.2.5 Test Result of 20dB Bandwidth

Refer as Appendix B

3.2.6 Test Result of Carrier Frequency Separation

Refer as Appendix B

3.3 Maximum Conducted Output Power

3.3.1 Maximum Conducted Output Power Limit

Maximum Conducted Output Power Limit	
<ul style="list-style-type: none"> 2400-2483.5 MHz Band: 	
	<ul style="list-style-type: none"> $N \geq 75$; Power 30dBm; EIRP 36dBm
	<ul style="list-style-type: none"> $75 > N \geq 15$; Power 21dBm; EIRP 27dBm
N: Number of Hopping Frequencies	

3.3.2 Measuring Instruments

Refer a test equipment and calibration data table in this test report.

3.3.3 Test Procedures

Test Method
<ul style="list-style-type: none"> Refer as ANSI C63.10-2013, clause 7.8.5 for output power measurement.

3.3.4 Test Setup

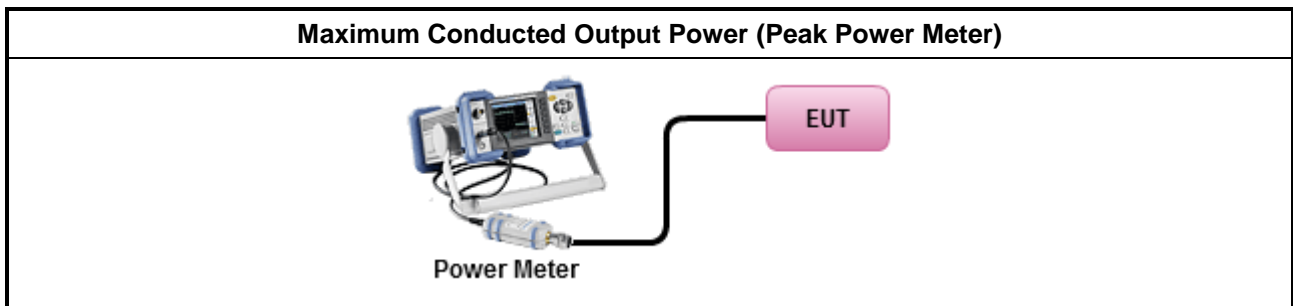

3.3.5 Test Result of Maximum Conducted Output Power

Refer as Appendix C

3.4 Number of Hopping Frequencies and Hopping Bandedge

3.4.1 Number of Hopping Frequencies Limit

Number of Hopping Frequencies Limit	
<ul style="list-style-type: none"> ▪ 2400-2483.5 MHz Band: 	
	<ul style="list-style-type: none"> ▪ $N \geq 75$ and $ChS \geq MAX$ (20 dB bandwidth, 25 kHz).
	<ul style="list-style-type: none"> ▪ $75 > N \geq 15$ and $ChS \geq MAX$ (20 dB bandwidth 2/3, 25 kHz).
N: Number of Hopping Frequencies; ChS : Hopping Channel Separation	

3.4.2 Hopping Bandedge Limit

Refer clause 3.6.1 and clause 3.7.1

3.4.3 Measuring Instruments

Refer a test equipment and calibration data table in this test report.

3.4.4 Test Procedures

Test Method
<ul style="list-style-type: none"> ▪ Refer as ANSI C63.10-2013, clause 7.8.3 for number of hopping frequencies measurement.
<ul style="list-style-type: none"> ▪ Refer as ANSI C63.10-2013, clause 7.8.6 for hopping frequencies Bandedge measurement.

3.4.5 Test Setup

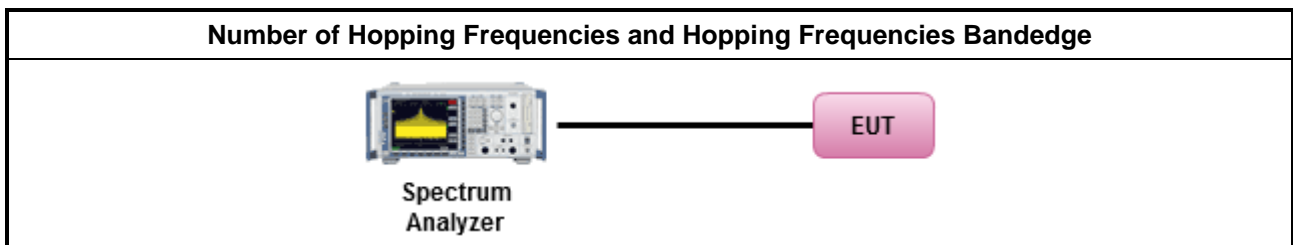

3.4.6 Test Result of Number of Hopping Frequencies

Refer as Appendix D

3.4.7 Test Result of Number of Hopping Frequencies Bandedge

Refer as Appendix D

3.5 Time of Occupancy (Dwell Time)

3.5.1 Time of Occupancy (Dwell Time) Limit

Time of Occupancy (Dwell Time) Limit for Frequency Hopping Systems	
<ul style="list-style-type: none"> 2400-2483.5 MHz Band: 	
	<ul style="list-style-type: none"> $N \geq 75$; 0.4s in $N \times 0.4$ period
	<ul style="list-style-type: none"> $75 > N \geq 15$; 0.4s in $N \times 0.4$ period
N: Number of Hopping Frequencies	

3.5.2 Measuring Instruments

Refer a test equipment and calibration data table in this test report.

3.5.3 Test Procedures

Test Method	
<ul style="list-style-type: none"> Refer as ANSI C63.10-2013, clause 7.8.4 for dwell time measurement. 	
<ul style="list-style-type: none"> Bluetooth ACL packets can be 1, 3, or 5 time slots. Following as dwell time. Operate DH5 at maximum dwell time and maximum duty cycle. 	
	<ul style="list-style-type: none"> The DH5 packet can cover up to 5 time slots. Operate DH5 at maximum dwell time and maximum duty cycle. A maximum length packet has duration of 5 time slots. The hopping rate is 1600 hops/second so the maximum dwell time is $5/1600$ seconds, or 3.125ms. DH5 Packet permit maximum $1600 / 79 / 6 = 3.37$ hops per second in each channel.

3.5.4 Test Setup

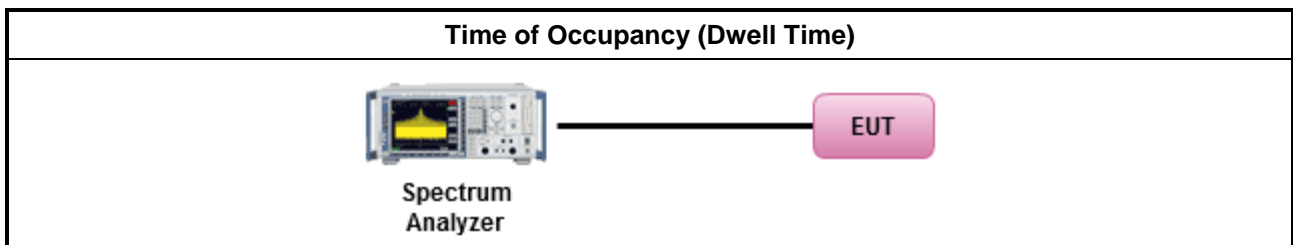

3.5.5 Test Result of Time of Occupancy (Dwell Time)

Refer as Appendix E

3.6 Emissions in Non-restricted Frequency Bands

3.6.1 Emissions in Non-restricted Frequency Bands Limit

Un-restricted Band Emissions Limit	
RF output power procedure	Limit (dB)
Peak output power procedure	20
Note 1: If the peak output power procedure is used to measure the fundamental emission power to demonstrate compliance to requirements, then the peak conducted output power measured within any 100 kHz outside the authorized frequency band shall be attenuated by at least 20 dB relative to the maximum measured in-band peak PSD level.	

3.6.2 Measuring Instruments

Refer a test equipment and calibration data table in this test report.

3.6.3 Test Procedures

Test Method
<ul style="list-style-type: none"> Refer as ANSI C63.10-2013, clause 7.8.8 for unwanted emissions into non-restricted bands.

3.6.4 Test Setup

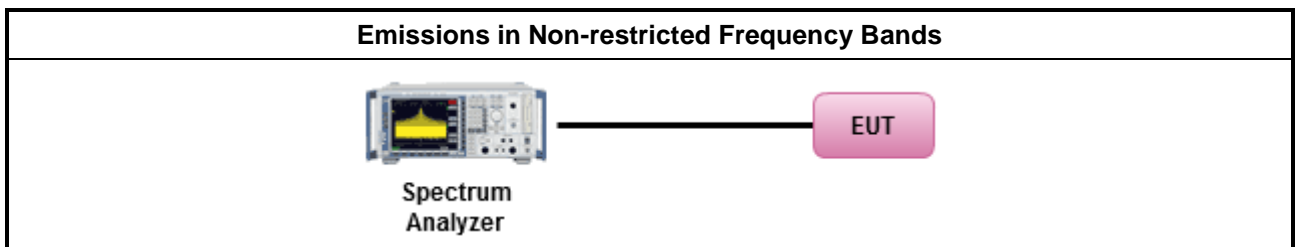

3.6.5 Test Result of Emissions in Non-restricted Frequency Bands

Refer as Appendix F

3.7 Emissions in Restricted Frequency Bands

3.7.1 Emissions in Restricted Frequency Bands Limit

Restricted Band Emissions Limit			
Frequency Range (MHz)	Field Strength (uV/m)	Field Strength (dBuV/m)	Measure Distance (m)
0.009~0.490	2400/F(kHz)	48.5 - 13.8	300
0.490~1.705	24000/F(kHz)	33.8 - 23	30
1.705~30.0	30	29	30
30~88	100	40	3
88~216	150	43.5	3
216~960	200	46	3
Above 960	500	54	3

Note 1: Test distance for frequencies at or above 30 MHz, measurements may be performed at a distance other than the limit distance provided they are not performed in the near field and the emissions to be measured can be detected by the measurement equipment. When performing measurements at a distance other than that specified, the results shall be extrapolated to the specified distance using an extrapolation factor of 20 dB/decade (inverse of linear distance for field-strength measurements, inverse of linear distance-squared for power-density measurements).

Note 2: Test distance for frequencies at below 30 MHz, measurements may be performed at a distance closer than the EUT limit distance; however, an attempt should be made to avoid making measurements in the near field. When performing measurements below 30 MHz at a closer distance than the limit distance, the results shall be extrapolated to the specified distance by either making measurements at a minimum of two or more distances on at least one radial to determine the proper extrapolation factor or by using the square of an inverse linear distance extrapolation factor (40 dB / decade). The test report shall specify the extrapolation method used to determine compliance of the EUT.

Note 3: Using the distance of 1m during the test for above 18 GHz, and the test value to correct for the distance factor at 3m.

3.7.2 Measuring Instruments

Refer a test equipment and calibration data table in this test report.

3.7.3 Test Procedures

Test Method	
	<ul style="list-style-type: none"> ▪ The average emission levels shall be measured in [hopping duty factor].
	<ul style="list-style-type: none"> ▪ Refer as ANSI C63.10; clause 6.9.2.2 band-edge testing shall be performed at the lowest frequency channel and highest frequency channel within the allowed operating band.
	<ul style="list-style-type: none"> ▪ For the transmitter unwanted emissions shall be measured using following options below: <ul style="list-style-type: none"> ▪ Refer as ANSI C63.10, clause 4.1.4.2.1 QP value. ▪ Refer as ANSI C63.10, clause 4.1.4.2.2 measurement procedure peak. ▪ Refer as ANSI C63.10, clause 4.1.4.2.4 average value of hopping pulsed emissions.

3.7.4 Test Setup

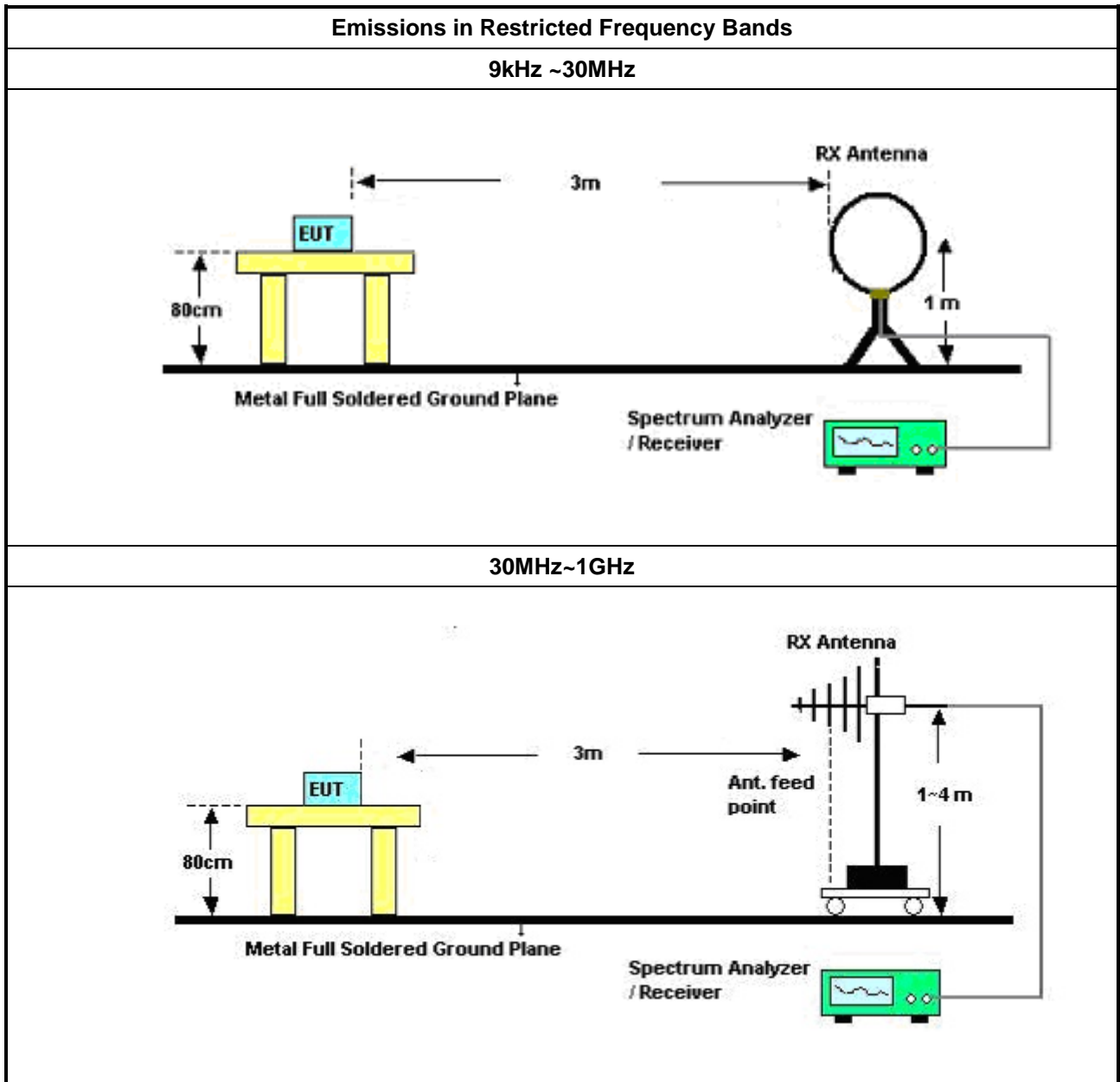

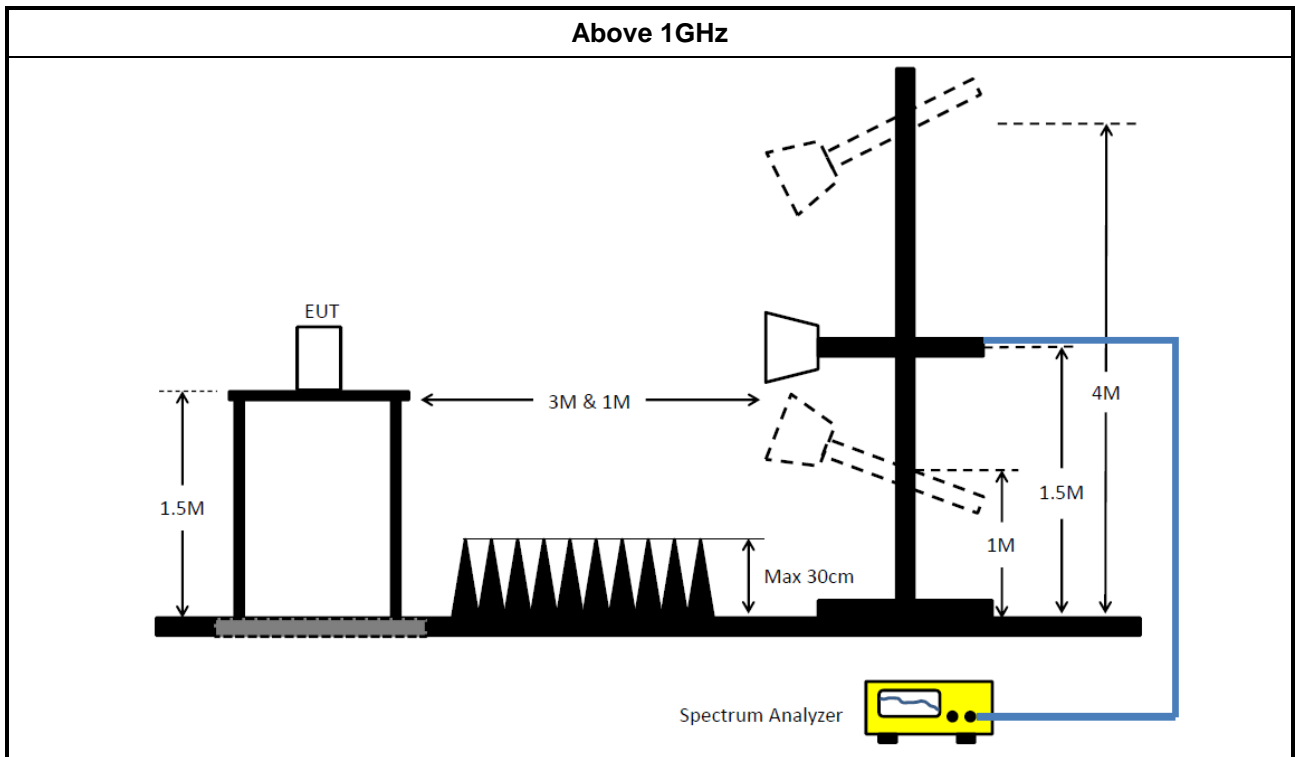

3.7.5 Test Result of Emissions in Restricted Frequency Bands (Below 30MHz)

The amplitude of spurious emissions which are attenuated by more than 20dB below the permissible value has no need to be reported.

3.7.6 Test Result of Emissions in Restricted Frequency Bands

Refer as Appendix G

4 Test Equipment and Calibration Data

Instrument for AC Conduction

Instrument	Manufacturer	Model No.	Serial No.	Spec.	Calibration Date	Calibration Due Date
EMC Receiver	R&S	ESR3	102052	9KHz ~ 3.6GHz	29/Apr/2017	28/Apr/2018
LISN	R&S	ENV216	101295	9kHz ~ 30MHz	17/Nov/2017	16/Nov/2018
RF Cable-CON	HUBER+SUHNER	RG213/U	07611832020001	9kHz ~ 30MHz	06/Oct/2017	05/Oct/2018
AC POWER	APC	AFC-11005G	F310050055	47Hz~63Hz 5~300V	NCR	NCR
Impuls Begrenzer Pulse Limiter	SCHWARZBECK	VTSD 9561-F	9561-F041	9 kHz ~ 30 MHz	12/Oct/2017	11/Oct/2018

NCR : Non-Calibration Require

Instrument for Radiated Test

Instrument	Manufacturer	Model No.	Serial No.	Spec.	Calibration Date	Calibration Due Date
3m Semi Anechoic Chamber	SIDT FRANKONIA	SAC-3M	03CH03-HY	30MHz ~ 1GHz 3m	31/Oct/2017	30/Oct/2018
3m Semi Anechoic Chamber	SIDT FRANKONIA	SAC-3M	03CH03-HY	1GHz ~ 18GHz 3m	01/Nov/2017	31/Oct/2018
Amplifier	HP	8447D	2944A08033	10kHz ~ 1.3GHz	19/Apr/2017	18/Apr/2018
Amplifier	Keysight	83017A	MY53270196	1GHz ~ 26.5GHz	31/Aug/2017	30/Aug/2018
Spectrum	R&S	FSV40	101500	9kHz ~ 40GHz	28/Jun/2017	27/Jun/2018
Receiver	R&S	ESR3	102052	9KHz ~ 3.6GHz	29/Apr/2017	28/Apr/2018
RF Cable-R03m	Jye Bao	RG142	CB021	9kHz ~ 1GHz	26/Jan/2018	25/Jan/2019
RF Cable-high	SUHNER	SUCOFLEX106	CB222	1GHz ~ 40GHz	26/Jan/2018	25/Jan/2019
Bilog Antenna	SCHAFFNER	CBL 6112B	22237	30MHz ~ 1GHz	08/Jul/2017	07/Jul/2018
Horn Antenna	SCHWARZBECK	BBHA9170	BBHA9170154	18GHz ~ 40GHz	06/Feb/ 2018	05/Feb/2019
Horn Antenna	SCHWARZBECK	BBHA9120D	1531	1GHz ~ 18GHz	25/Apr/ 2017	24/Apr/2018

Instrument for Conducted Test

Instrument	Manufacturer	Model No.	Serial No.	Spec.	Calibration Date	Calibration Due Date
Spectrum Analyzer	R&S	FSV 40	101515	9kHz~40GHz	08/Dec/2017	07/Dec/2018
Power Sensor	Anritsu	MA2411B	1339407	300MHz ~ 40GHz	10/May/2017	09/May/2018
Power Meter	Anritsu	ML2495A	1517010	300MHz ~ 40GHz	06/Nov/2017	05/Nov/2018
Signal Generator	R&S	SMR40	100116	10MHz ~ 40GHz	27/Jul/2017	26/Jul/2018
RF Cable-0.2m	HUBER+SUHNER	SUCOFLEX_104	MY677/3	30MHz ~ 26.5GHz	25/Aug/2017	24/Aug/2018
RF Cable-0.2m	HUBER+SUHNER	SUCOFLEX_104	MY678/3	30MHz ~ 26.5GHz	25/Aug/2017	24/Aug/2018
RF Cable-0.5m	HUBER+SUHNER	SUCOFLEX_104	MY10717/4	30MHz ~ 26.5GHz	25/Aug/2017	24/Aug/2018



AC Power-line Conducted Emissions Result																																																																																																																																	
Operating Mode	1	Power Phase	Neutral																																																																																																																														
Operating Function	USB Mode ; BT 2.1+EDR TX																																																																																																																																
<div style="display: flex; justify-content: space-between;"> <div> </div> <div style="text-align: right;">Date: 2018-03-17</div> </div>																																																																																																																																	
<table border="1" style="width: 100%; border-collapse: collapse; margin-top: 10px;"> <thead> <tr> <th></th> <th>Freq</th> <th>Level</th> <th>Over Limit</th> <th>Limit Line</th> <th>Read Level</th> <th>LISN Factor</th> <th>Cable Loss</th> <th>Remark</th> </tr> <tr> <th></th> <th>MHz</th> <th>dBuV</th> <th>dB</th> <th>dBuV</th> <th>dBuV</th> <th>dB</th> <th>dB</th> <th></th> </tr> </thead> <tbody> <tr><td>1</td><td>0.1516</td><td>32.09</td><td>-23.82</td><td>55.91</td><td>22.42</td><td>9.63</td><td>0.04</td><td>Average</td></tr> <tr><td>2</td><td>0.1516</td><td>40.48</td><td>-25.43</td><td>65.91</td><td>30.81</td><td>9.63</td><td>0.04</td><td>QP</td></tr> <tr><td>3</td><td>0.3392</td><td>27.16</td><td>-22.06</td><td>49.22</td><td>17.47</td><td>9.61</td><td>0.08</td><td>Average</td></tr> <tr><td>4</td><td>0.3392</td><td>34.90</td><td>-24.32</td><td>59.22</td><td>25.21</td><td>9.61</td><td>0.08</td><td>QP</td></tr> <tr><td>5 MAX</td><td>0.4564</td><td>33.00</td><td>-13.76</td><td>46.76</td><td>23.30</td><td>9.61</td><td>0.09</td><td>Average</td></tr> <tr><td>6</td><td>0.4564</td><td>37.54</td><td>-19.22</td><td>56.76</td><td>27.84</td><td>9.61</td><td>0.09</td><td>QP</td></tr> <tr><td>7</td><td>1.7529</td><td>28.72</td><td>-17.28</td><td>46.00</td><td>19.09</td><td>9.63</td><td>0.00</td><td>Average</td></tr> <tr><td>8</td><td>1.7529</td><td>35.67</td><td>-20.33</td><td>56.00</td><td>26.04</td><td>9.63</td><td>0.00</td><td>QP</td></tr> <tr><td>9</td><td>2.2132</td><td>32.06</td><td>-13.94</td><td>46.00</td><td>22.42</td><td>9.63</td><td>0.01</td><td>Average</td></tr> <tr><td>10</td><td>2.2132</td><td>40.49</td><td>-15.51</td><td>56.00</td><td>30.85</td><td>9.63</td><td>0.01</td><td>QP</td></tr> <tr><td>11</td><td>6.4539</td><td>22.55</td><td>-27.45</td><td>50.00</td><td>12.73</td><td>9.67</td><td>0.15</td><td>Average</td></tr> <tr><td>12</td><td>6.4539</td><td>28.93</td><td>-31.07</td><td>60.00</td><td>19.11</td><td>9.67</td><td>0.15</td><td>QP</td></tr> </tbody> </table>					Freq	Level	Over Limit	Limit Line	Read Level	LISN Factor	Cable Loss	Remark		MHz	dBuV	dB	dBuV	dBuV	dB	dB		1	0.1516	32.09	-23.82	55.91	22.42	9.63	0.04	Average	2	0.1516	40.48	-25.43	65.91	30.81	9.63	0.04	QP	3	0.3392	27.16	-22.06	49.22	17.47	9.61	0.08	Average	4	0.3392	34.90	-24.32	59.22	25.21	9.61	0.08	QP	5 MAX	0.4564	33.00	-13.76	46.76	23.30	9.61	0.09	Average	6	0.4564	37.54	-19.22	56.76	27.84	9.61	0.09	QP	7	1.7529	28.72	-17.28	46.00	19.09	9.63	0.00	Average	8	1.7529	35.67	-20.33	56.00	26.04	9.63	0.00	QP	9	2.2132	32.06	-13.94	46.00	22.42	9.63	0.01	Average	10	2.2132	40.49	-15.51	56.00	30.85	9.63	0.01	QP	11	6.4539	22.55	-27.45	50.00	12.73	9.67	0.15	Average	12	6.4539	28.93	-31.07	60.00	19.11	9.67	0.15	QP
	Freq	Level	Over Limit	Limit Line	Read Level	LISN Factor	Cable Loss	Remark																																																																																																																									
	MHz	dBuV	dB	dBuV	dBuV	dB	dB																																																																																																																										
1	0.1516	32.09	-23.82	55.91	22.42	9.63	0.04	Average																																																																																																																									
2	0.1516	40.48	-25.43	65.91	30.81	9.63	0.04	QP																																																																																																																									
3	0.3392	27.16	-22.06	49.22	17.47	9.61	0.08	Average																																																																																																																									
4	0.3392	34.90	-24.32	59.22	25.21	9.61	0.08	QP																																																																																																																									
5 MAX	0.4564	33.00	-13.76	46.76	23.30	9.61	0.09	Average																																																																																																																									
6	0.4564	37.54	-19.22	56.76	27.84	9.61	0.09	QP																																																																																																																									
7	1.7529	28.72	-17.28	46.00	19.09	9.63	0.00	Average																																																																																																																									
8	1.7529	35.67	-20.33	56.00	26.04	9.63	0.00	QP																																																																																																																									
9	2.2132	32.06	-13.94	46.00	22.42	9.63	0.01	Average																																																																																																																									
10	2.2132	40.49	-15.51	56.00	30.85	9.63	0.01	QP																																																																																																																									
11	6.4539	22.55	-27.45	50.00	12.73	9.67	0.15	Average																																																																																																																									
12	6.4539	28.93	-31.07	60.00	19.11	9.67	0.15	QP																																																																																																																									
<p>Note 1: ">20dB" means emission levels that exceed the level of 20 dB below the applicable limit. Note 2: "N/F" means Nothing Found emissions (No emissions were detected.)</p>																																																																																																																																	



AC Power-line Conducted Emissions Result

Operating Mode	1	Power Phase	Line
Operating Function	USB Mode ; BT 2.1+EDR TX		

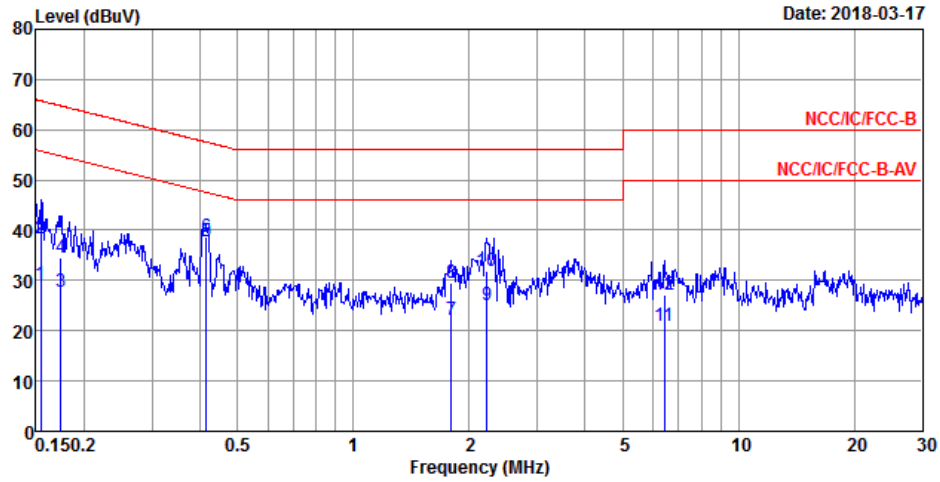

	Freq	Level	Over Limit	Limit Line	Read Level	LISN Factor	Cable Loss	Remark
	MHz	dBuV	dB	dBuV	dBuV	dB	dB	
1	0.1540	29.32	-26.46	55.78	19.66	9.62	0.04	Average
2	0.1540	38.27	-27.51	65.78	28.61	9.62	0.04	QP
3	0.1740	27.77	-27.00	54.77	18.13	9.62	0.02	Average
4	0.1740	34.48	-30.29	64.77	24.84	9.62	0.02	QP
5 MAX	0.4148	37.92	-9.63	47.55	28.21	9.61	0.10	Average
6	0.4148	38.58	-18.97	57.55	28.87	9.61	0.10	QP
7	1.8000	22.26	-23.74	46.00	12.64	9.62	0.00	Average
8	1.8000	29.55	-26.45	56.00	19.93	9.62	0.00	QP
9	2.2249	25.01	-20.99	46.00	15.38	9.62	0.01	Average
10	2.2249	31.73	-24.27	56.00	22.10	9.62	0.01	QP
11	6.4198	21.00	-29.00	50.00	11.20	9.65	0.15	Average
12	6.4198	27.09	-32.91	60.00	17.29	9.65	0.15	QP

Note 1: ">20dB" means emission levels that exceed the level of 20 dB below the applicable limit.
 Note 2: "N/F" means Nothing Found emissions (No emissions were detected.)



Summary

Mode	Max-N dB (Hz)	Max-OBW (Hz)	ITU-Code	Min-N dB (Hz)	Min-OBW (Hz)
2.4-2.4835GHz	-	-	-	-	-
BT-BR(1Mbps)	917.5k	865.817k	866KF1D	912.5k	857.071k
BT-EDR(2Mbps)	1.253M	1.202M	1M20G1D	1.195M	1.193M
BT-EDR(3Mbps)	1.244M	1.206M	1M21G1D	1.226M	1.198M

Max-N dB = Maximum 20dB down bandwidth; **Max-OBW** = Maximum 99% occupied bandwidth;
Min-N dB = Minimum 20dB down bandwidth; **Min-OBW** = Minimum 99% occupied bandwidth;

Result

Mode	Result	Limit (Hz)	Port 1-N dB (Hz)	Port 1-OBW (Hz)
BT-BR(1Mbps)	-	-	-	-
2402MHz	Pass	Inf	912.5k	857.071k
2441MHz	Pass	Inf	916.25k	860.82k
2480MHz	Pass	Inf	917.5k	865.817k
BT-EDR(2Mbps)	-	-	-	-
2402MHz	Pass	Inf	1.226M	1.197M
2441MHz	Pass	Inf	1.253M	1.202M
2480MHz	Pass	Inf	1.195M	1.193M
BT-EDR(3Mbps)	-	-	-	-
2402MHz	Pass	Inf	1.241M	1.206M
2441MHz	Pass	Inf	1.244M	1.198M
2480MHz	Pass	Inf	1.226M	1.198M

Port X-N dB = Port X 20dB down bandwidth; **Port X-OBW** = Port X 99% occupied bandwidth;

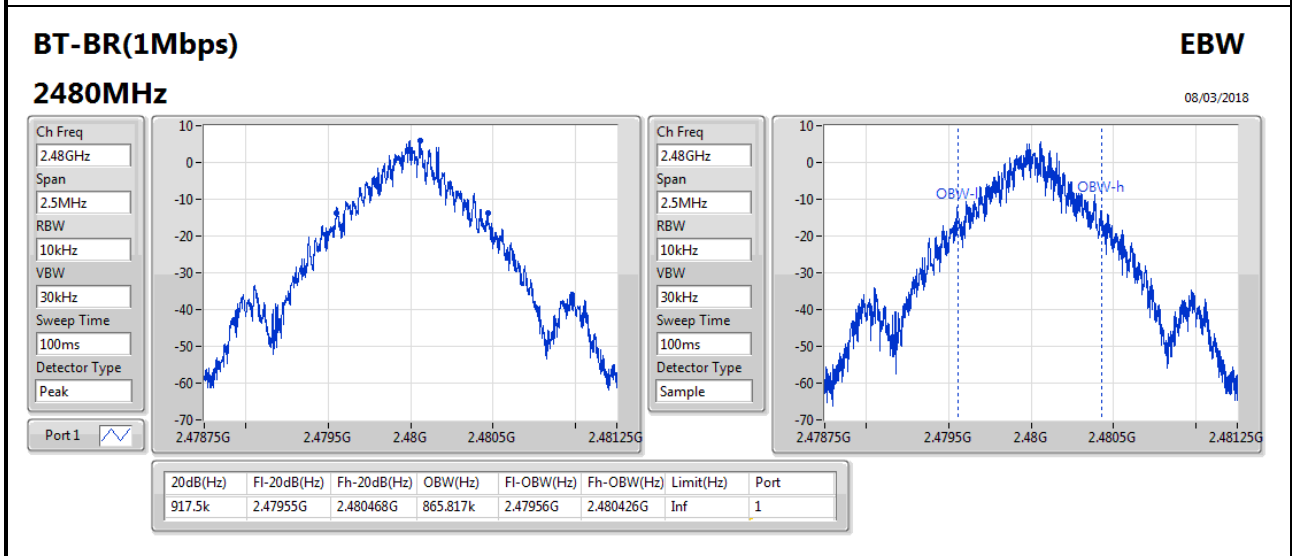
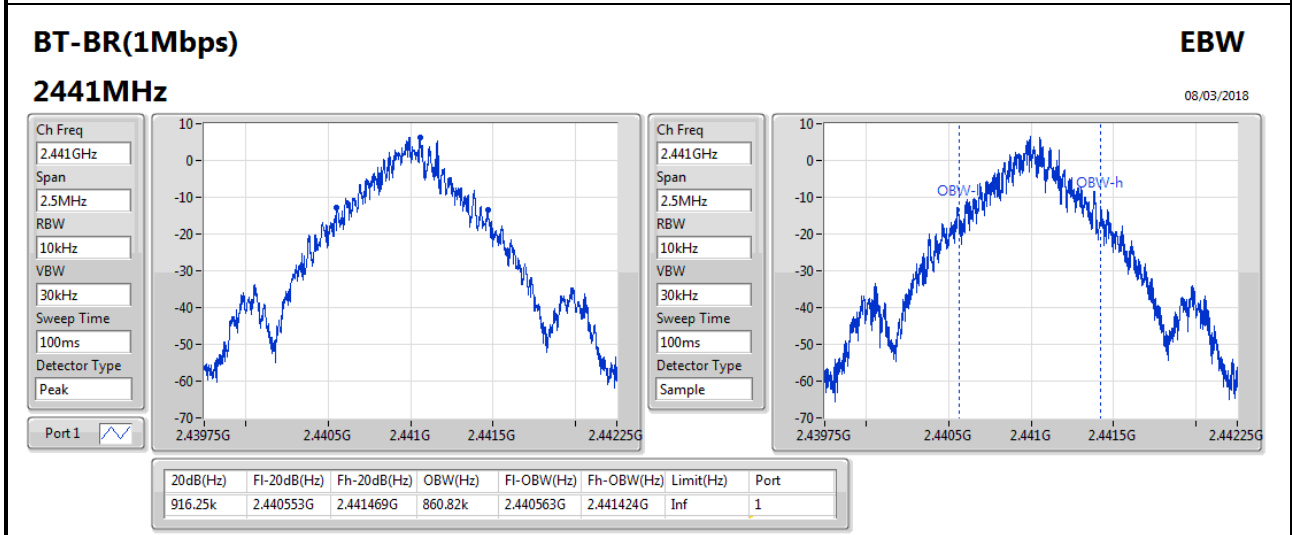
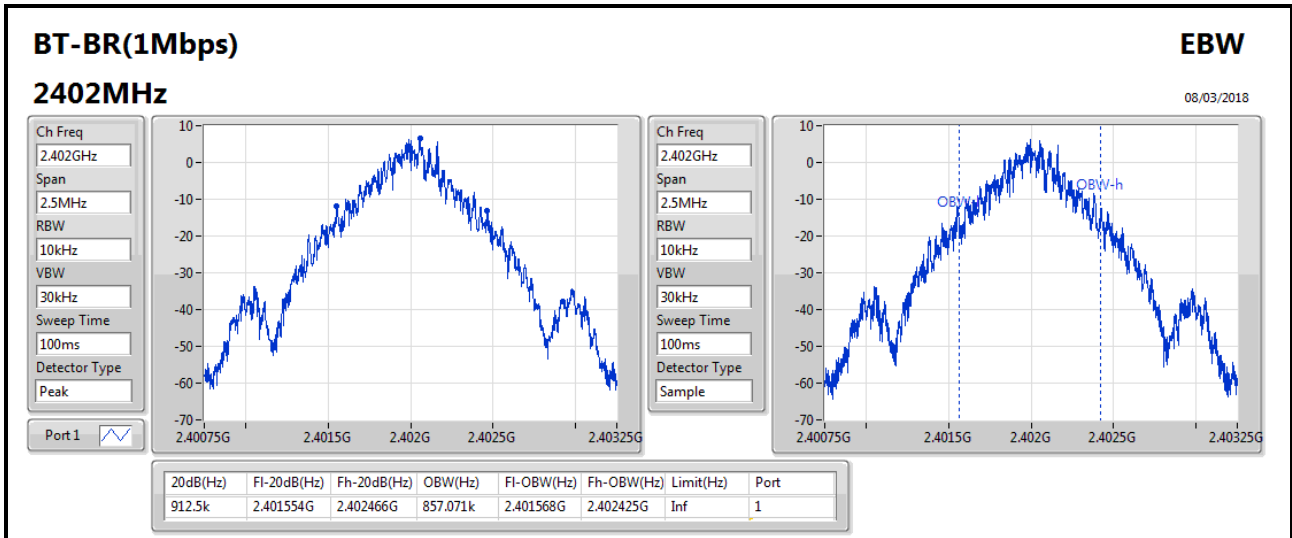

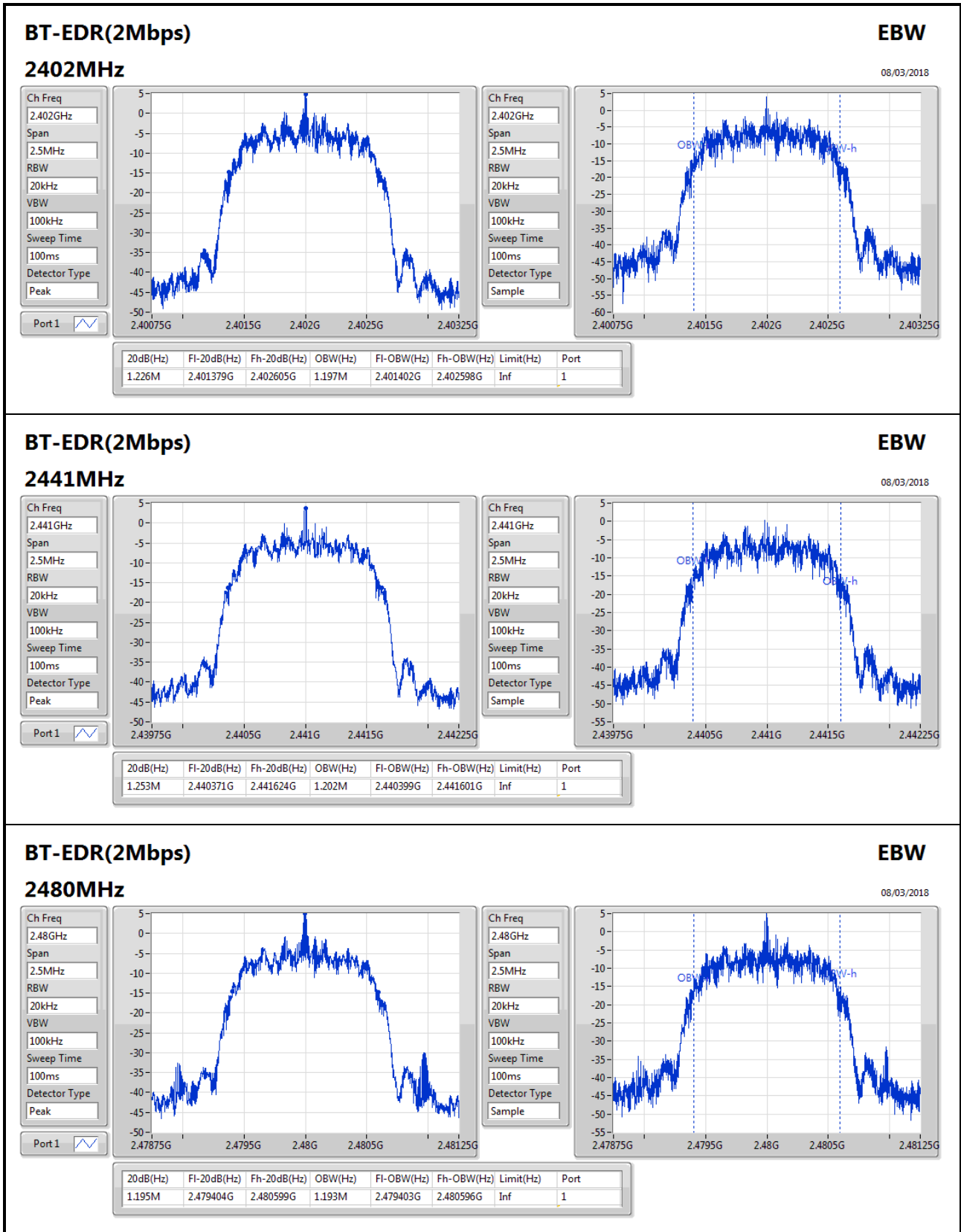

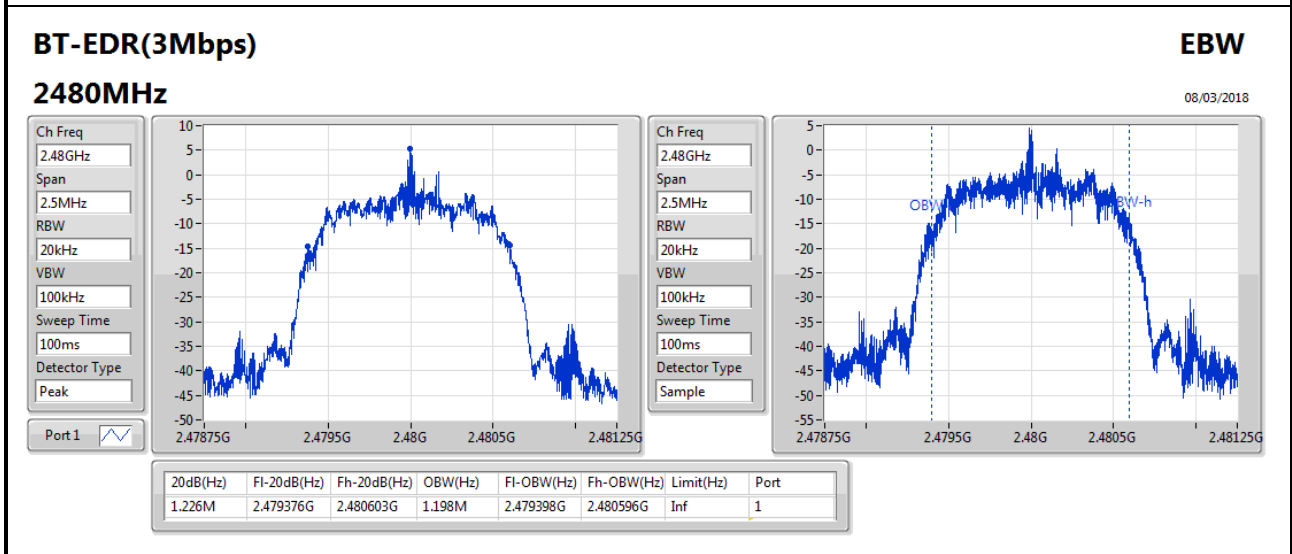
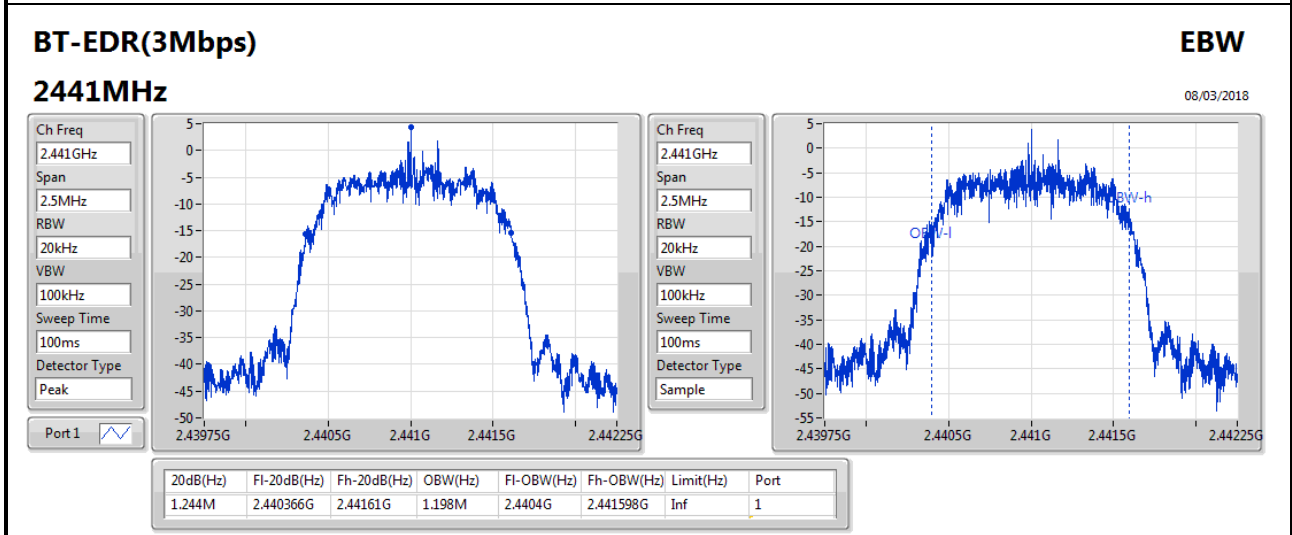
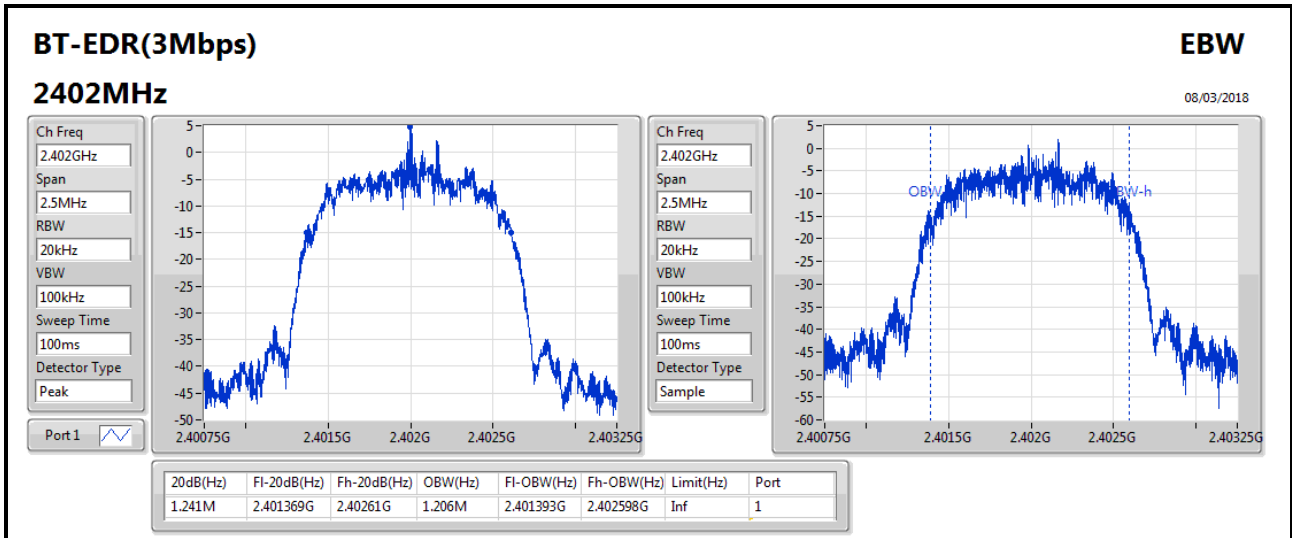



Summary

Mode	Max-Space (Hz)	Min-Space (Hz)
2.4-2.4835GHz	-	-
BT-BR(1Mbps)	1.002M	1.0005M
BT-EDR(2Mbps)	1.002M	999k
BT-EDR(3Mbps)	1.002M	1.0005M

Result

Mode	Result	Fl (Hz)	Fh (Hz)	Ch.Space (Hz)	Limit (Hz)
BT-BR(1Mbps)	-	-	-	-	-
2402MHz	Pass	2.401998G	2.403G	1.002M	607.725k
2441MHz	Pass	2.440999G	2.442G	1.0005M	610.2225k
2480MHz	Pass	2.478999G	2.48G	1.0005M	611.055k
BT-EDR(2Mbps)	-	-	-	-	-
2402MHz	Pass	2.401999G	2.403G	1.0005M	816.516k
2441MHz	Pass	2.441001G	2.442G	999k	834.498k
2480MHz	Pass	2.478998G	2.48G	1.002M	795.87k
BT-EDR(3Mbps)	-	-	-	-	-
2402MHz	Pass	2.401998G	2.403G	1.002M	826.506k
2441MHz	Pass	2.440999G	2.442G	1.0005M	828.504k
2480MHz	Pass	2.478999G	2.480001G	1.002M	816.516k

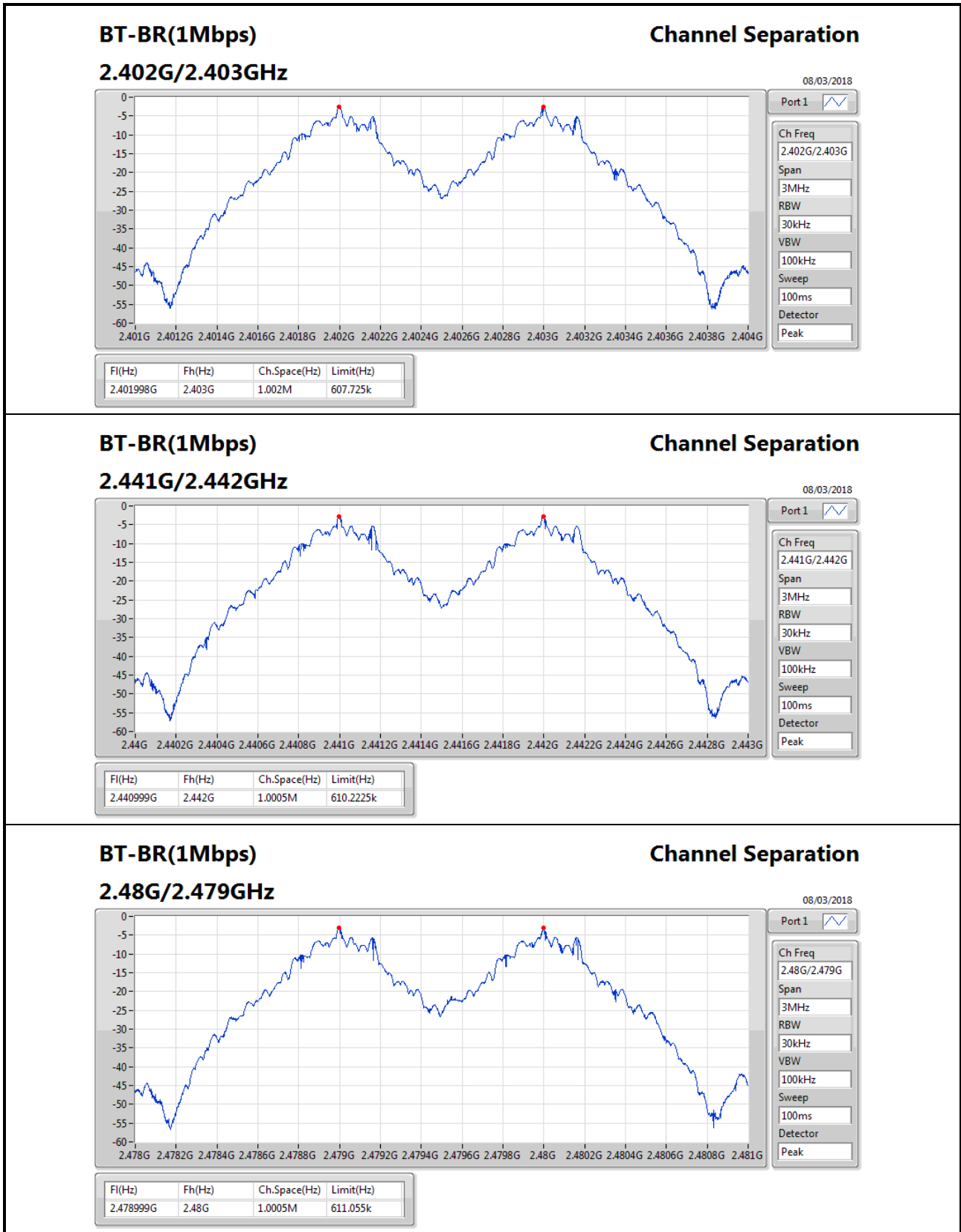

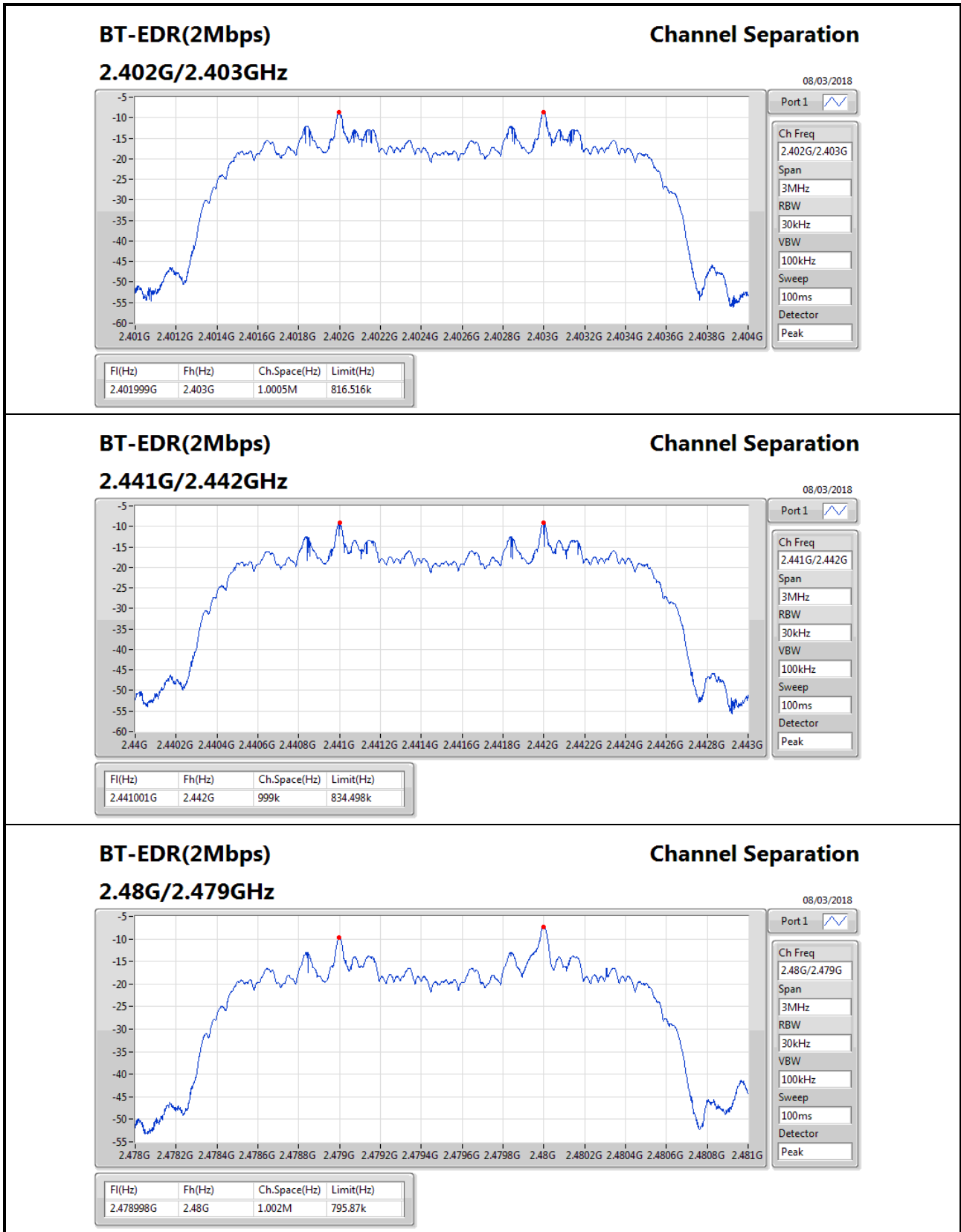

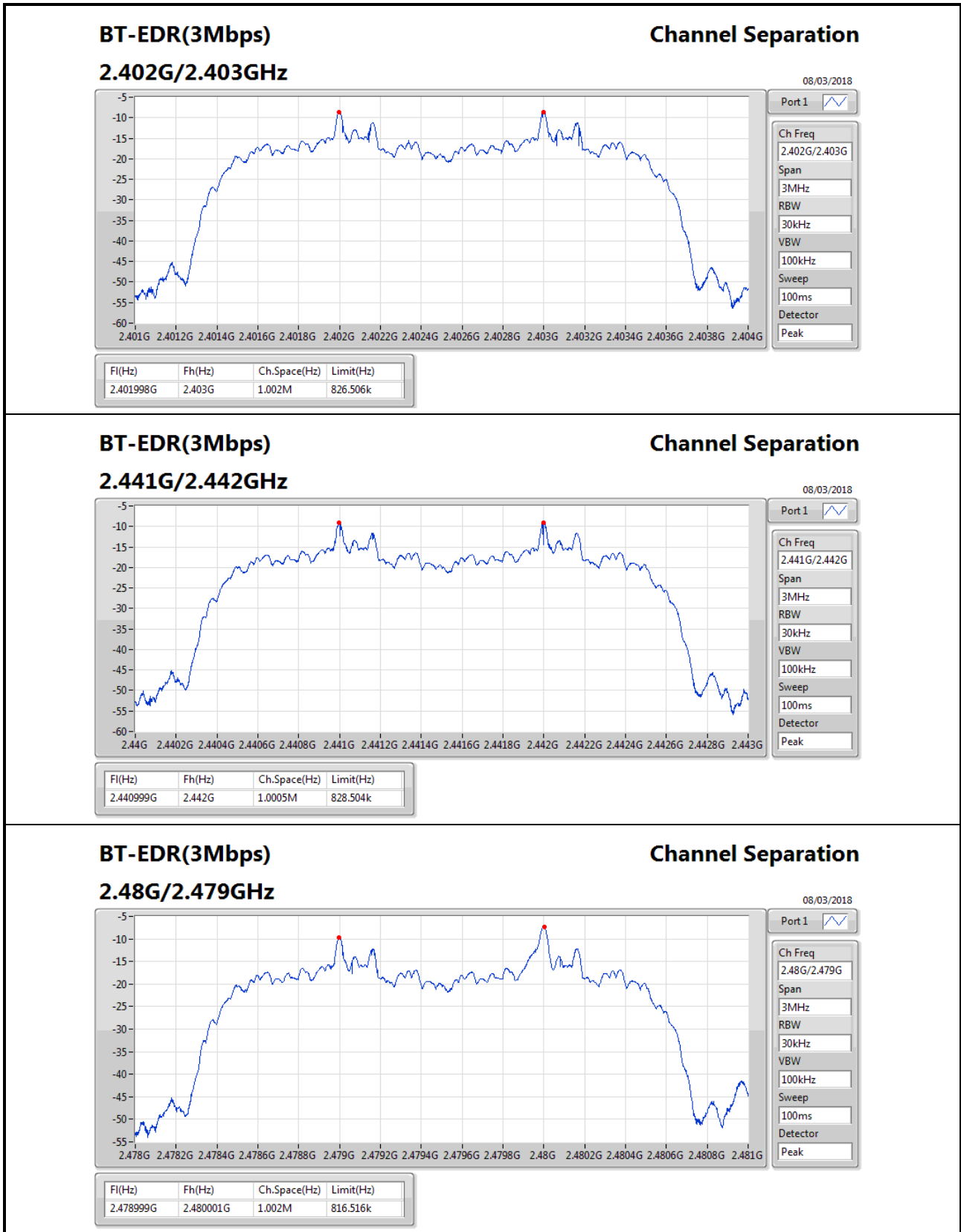



Summary

Mode	Power (dBm)	Power (W)
2.4-2.4835GHz	-	-
BT-BR(1Mbps)	12.32	0.01706
BT-EDR(2Mbps)	8.69	0.00740
BT-EDR(3Mbps)	9.28	0.00847

Result

Mode	Result	Gain (dBi)	Power (dBm)	Power Limit (dBm)
BT-BR(1Mbps)	-	-	-	-
2402MHz	Pass	2.15	12.32	21.00
2441MHz	Pass	2.15	12.19	21.00
2480MHz	Pass	2.15	11.92	21.00
BT-EDR(2Mbps)	-	-	-	-
2402MHz	Pass	2.15	8.69	21.00
2441MHz	Pass	2.15	8.49	21.00
2480MHz	Pass	2.15	8.51	21.00
BT-EDR(3Mbps)	-	-	-	-
2402MHz	Pass	2.15	9.28	21.00
2441MHz	Pass	2.15	8.91	21.00
2480MHz	Pass	2.15	8.52	21.00



Summary

Mode	Power (dBm)	Power (W)
2.4-2.4835GHz	-	-
BT-BR(1Mbps)	10.07	0.01016
BT-EDR(2Mbps)	5.91	0.00390
BT-EDR(3Mbps)	5.16	0.00328

Result

Mode	Result	Gain (dBi)	Power (dBm)	Power Limit (dBm)
BT-BR(1Mbps)	-	-	-	-
2402MHz	Pass	2.15	10.07	21.00
2441MHz	Pass	2.15	10.05	21.00
2480MHz	Pass	2.15	9.81	21.00
BT-EDR(2Mbps)	-	-	-	-
2402MHz	Pass	2.15	5.14	21.00
2441MHz	Pass	2.15	5.91	21.00
2480MHz	Pass	2.15	5.29	21.00
BT-EDR(3Mbps)	-	-	-	-
2402MHz	Pass	2.15	5.16	21.00
2441MHz	Pass	2.15	4.93	21.00
2480MHz	Pass	2.15	4.98	21.00



Summary

Mode	Max-Hop No
2.4-2.4835GHz	-
BT-BR(1Mbps)	79
BT-EDR(2Mbps)	79
BT-EDR(3Mbps)	79

Result

Mode	Result	Hopping No	Limit
BT-BR(1Mbps)	-	-	-
2441MHz	Pass	79	15
BT-EDR(2Mbps)	-	-	-
2441MHz	Pass	79	15
BT-EDR(3Mbps)	-	-	-
2441MHz	Pass	79	15

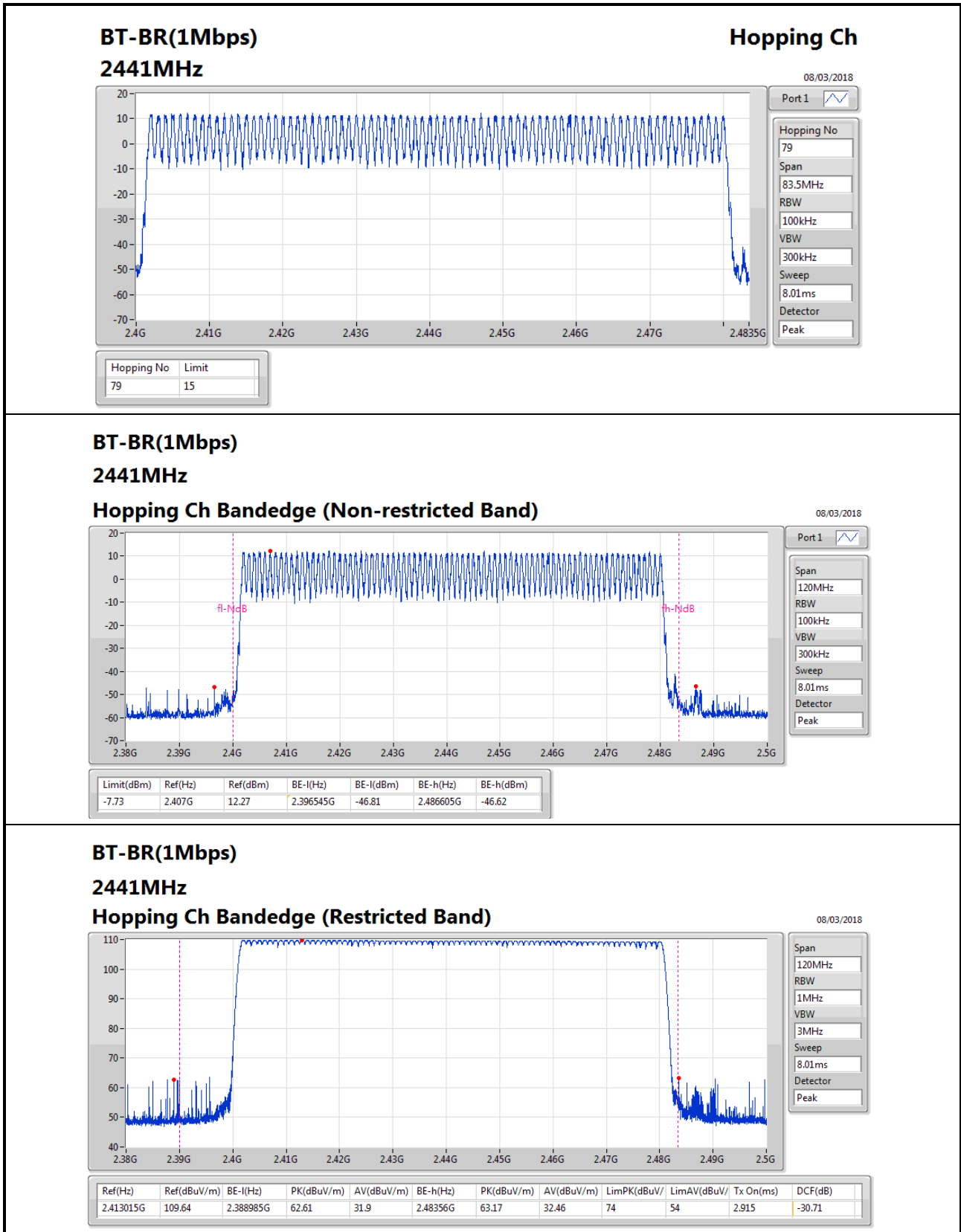

BT-BR(1Mbps)

2441MHz

Hopping Ch Bandedge (Restricted Band)

08/03/2018

Span: 120MHz

RBW: 1MHz

VBW: 3MHz

Sweep: 8.01ms

Detector: Peak

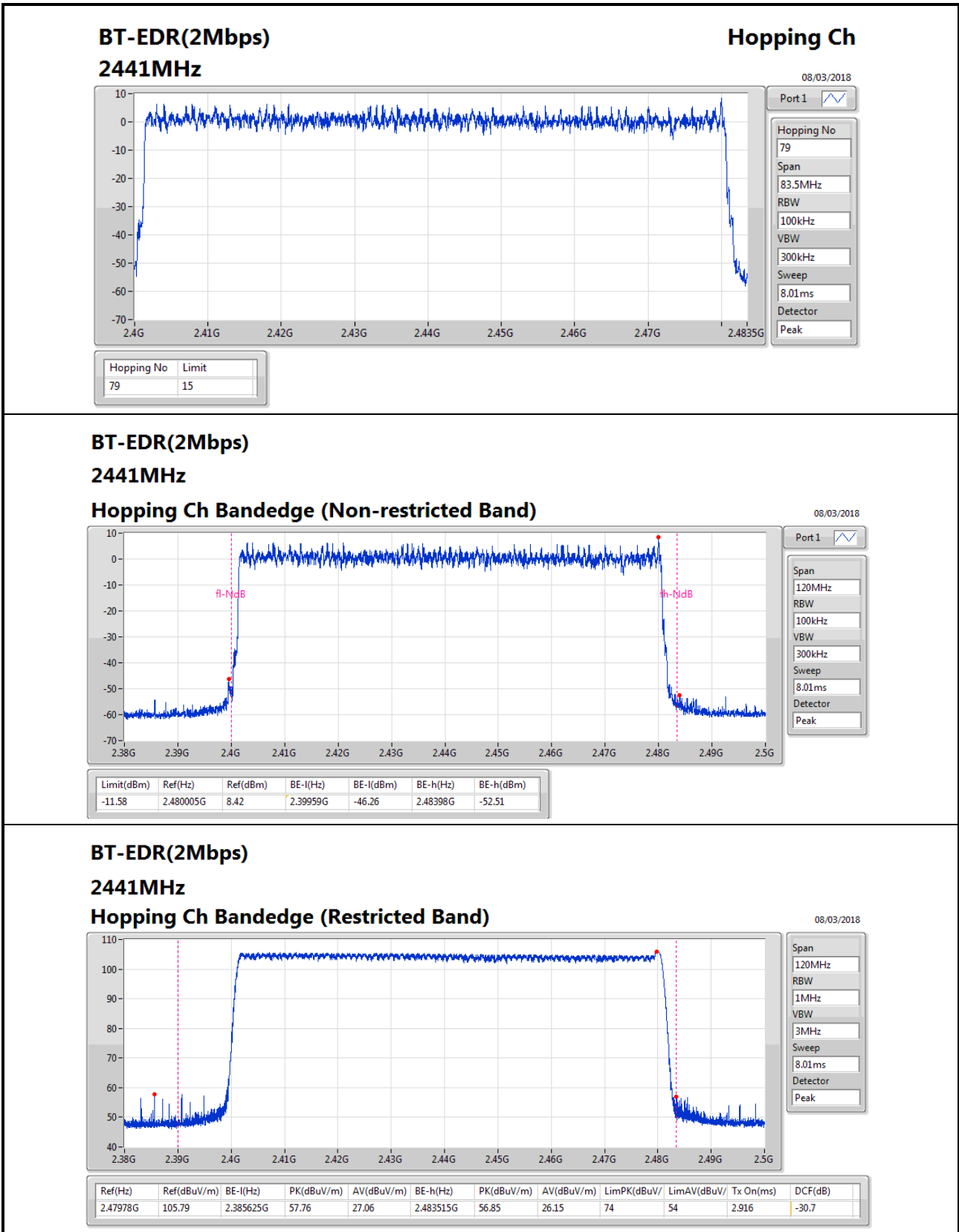

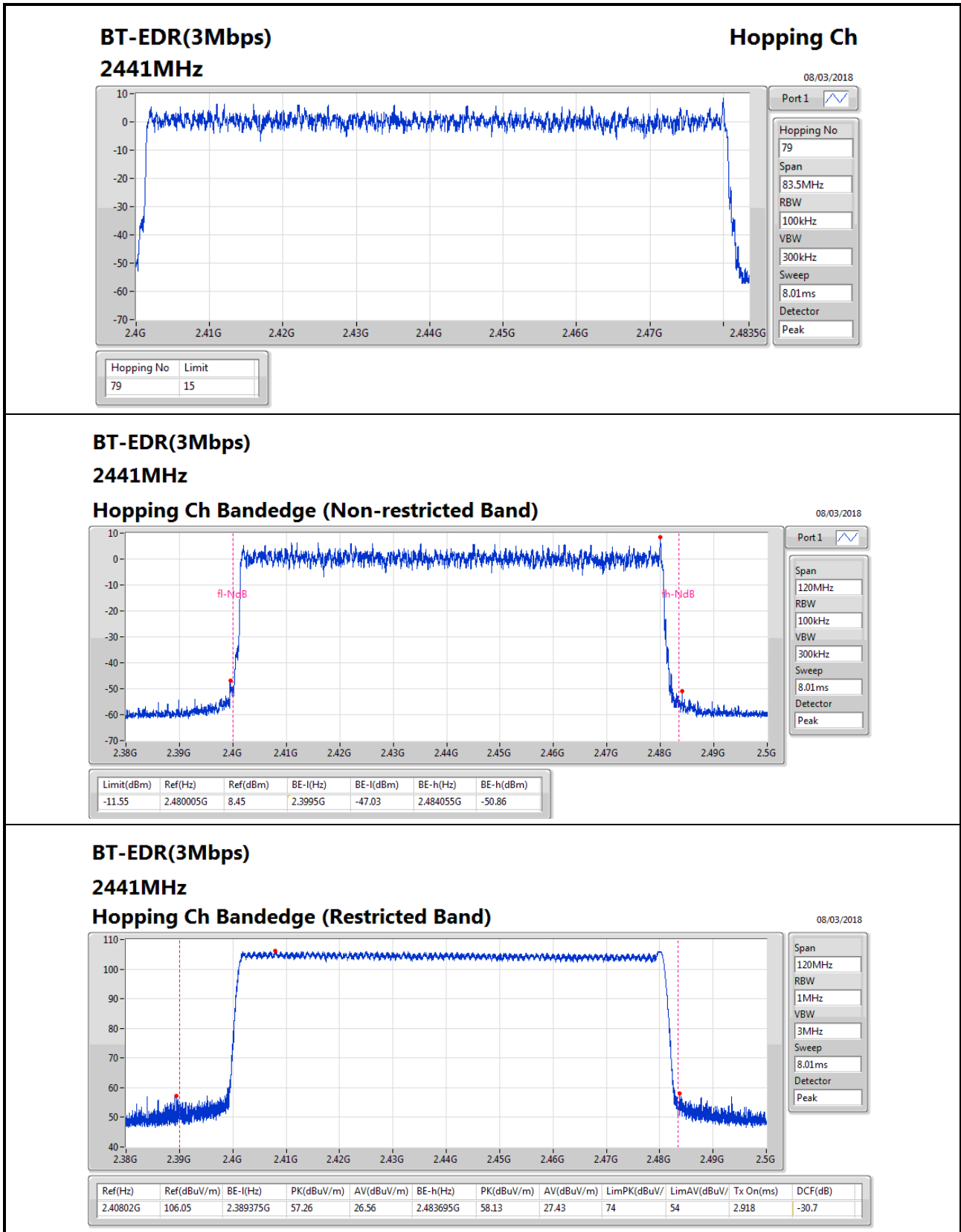



Summary

Mode	Max-Dwell (s)
2.4-2.4835GHz	-
BT-BR(1Mbps)	310.739m
BT-EDR(2Mbps)	310.8456m
BT-EDR(3Mbps)	311.0588m

Result

Mode	Result	Period (s)	Dwell (s)	Limit (s)	Tx On (s)
BT-BR(1Mbps)	-	-	-	-	-
2441MHz	Pass	31.6	310.739m	400m	2.915m
BT-EDR(2Mbps)	-	-	-	-	-
2441MHz	Pass	31.6	310.8456m	400m	2.916m
BT-EDR(3Mbps)	-	-	-	-	-
2441MHz	Pass	31.6	311.0588m	400m	2.918m

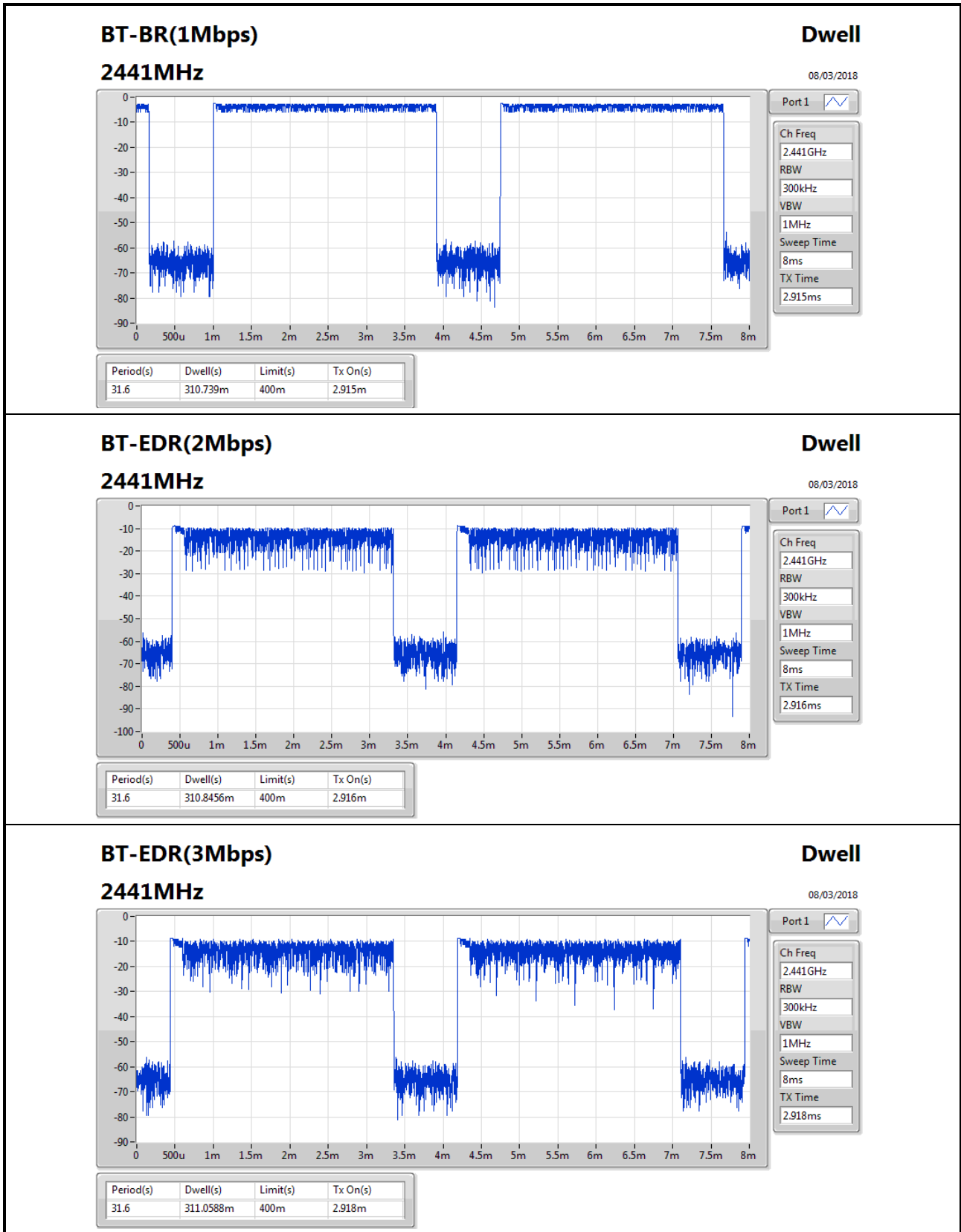



Summary

Mode	Result	Ref (Hz)	Ref (dBm)	Limit (dBm)	Freq (Hz)	Level (dBm)	Freq (Hz)	Level (dBm)	Freq (Hz)	Level (dBm)	Freq (Hz)	Level (dBm)	Port
2.4-2.4835GHz	-	-	-	-	-	-	-	-	-	-	-	-	-
BT-BR(1Mbps)	Pass	2.402004G	10.92	-9.08	800.784M	-52.63	2.399996G	-43.50	2.484G	-51.54	6.977143G	-52.76	1
BT-EDR(2Mbps)	Pass	2.401837G	4.11	-15.89	2.398G	-57.62	2.39954G	-43.77	2.484984G	-52.80	6.994029G	-52.56	1
BT-EDR(3Mbps)	Pass	2.401837G	3.72	-16.28	2.398G	-54.08	2.399532G	-43.57	2.483536G	-52.92	6.273565G	-53.74	1

Result

Mode	Result	Ref (Hz)	Ref (dBm)	Limit (dBm)	Freq (Hz)	Level (dBm)	Freq (Hz)	Level (dBm)	Freq (Hz)	Level (dBm)	Freq (Hz)	Level (dBm)	Port
BT-BR(1Mbps)	-	-	-	-	-	-	-	-	-	-	-	-	-
2402MHz	Pass	2.402004G	10.92	-9.08	800.784M	-52.63	2.399996G	-43.50	2.484G	-51.54	6.977143G	-52.76	1
2441MHz	Pass	2.440915G	11.23	-8.77	813.808M	-52.04	2.39846G	-56.15	2.484068G	-52.48	6.327037G	-53.53	1
2480MHz	Pass	2.48016G	11.78	-8.22	826.832M	-52.14	2.399736G	-58.97	2.483524G	-46.21	6.813913G	-53.40	1
BT-EDR(2Mbps)	-	-	-	-	-	-	-	-	-	-	-	-	-
2402MHz	Pass	2.401837G	4.11	-15.89	2.398G	-57.62	2.39954G	-43.77	2.484984G	-52.80	6.994029G	-52.56	1
2441MHz	Pass	2.440915G	2.89	-17.11	2.163568G	-58.23	2.398444G	-58.19	2.483828G	-51.69	6.341108G	-53.15	1
2480MHz	Pass	2.480327G	1.99	-18.01	826.832M	-58.60	2.399196G	-58.79	2.483992G	-51.63	6.21165G	-53.08	1
BT-EDR(3Mbps)	-	-	-	-	-	-	-	-	-	-	-	-	-
2402MHz	Pass	2.401837G	3.72	-16.28	2.398G	-54.08	2.399532G	-43.57	2.483536G	-52.92	6.273565G	-53.74	1
2441MHz	Pass	2.441082G	2.69	-17.31	2.17304G	-59.81	2.398268G	-58.09	2.483912G	-52.80	6.991214G	-53.02	1
2480MHz	Pass	2.479826G	2.56	-17.44	826.832M	-58.69	2.398856G	-58.59	2.484428G	-52.43	6.996843G	-52.65	1

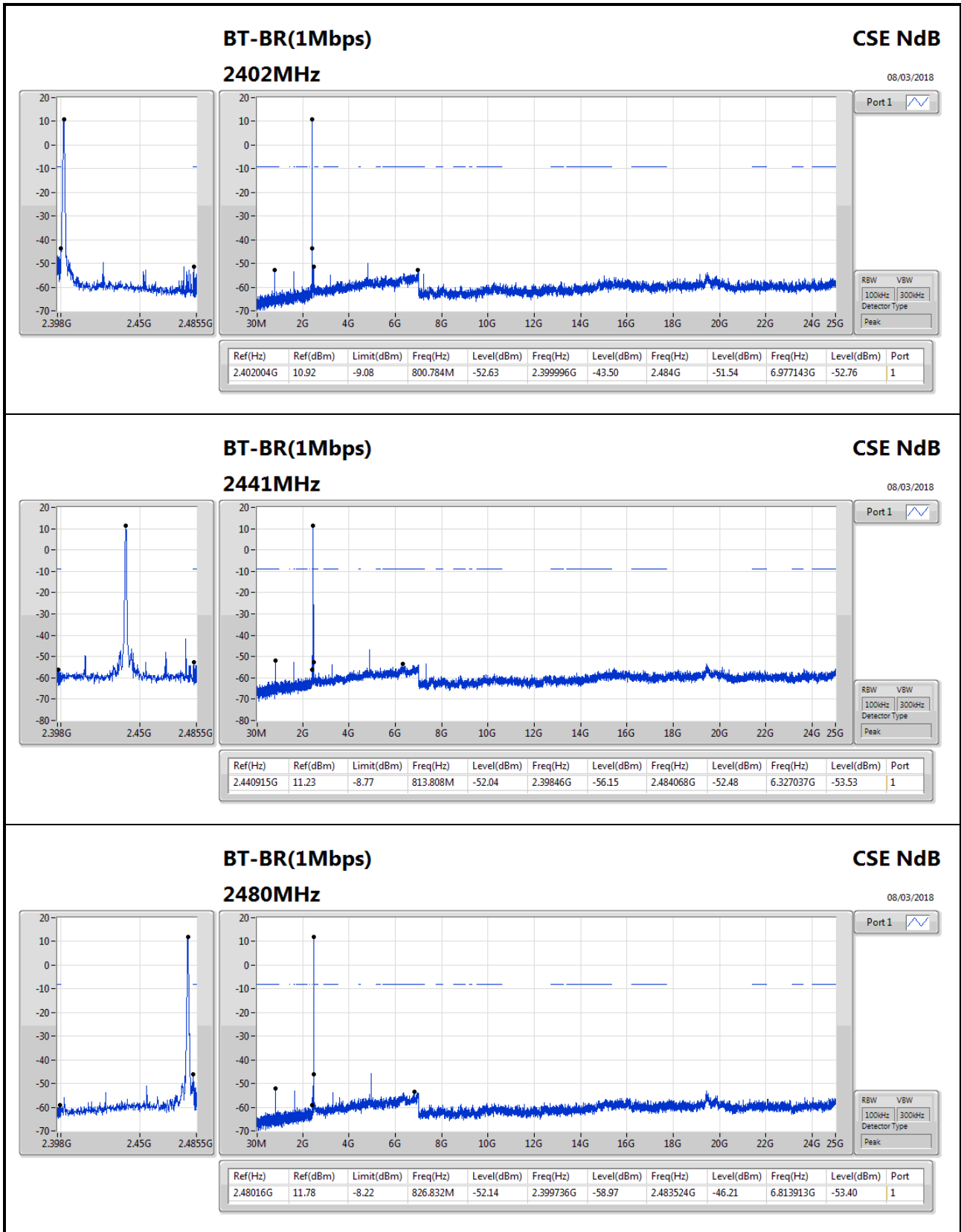

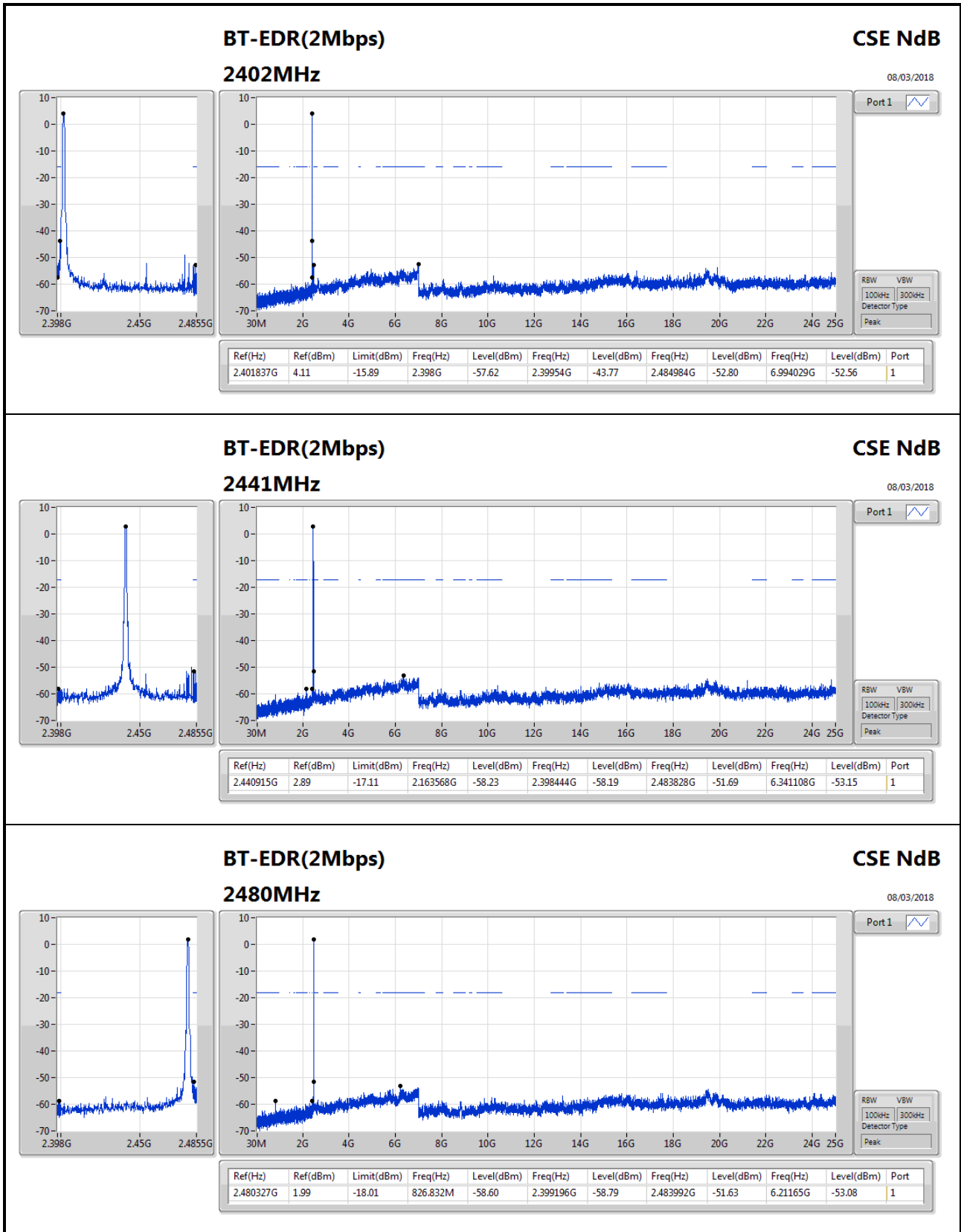

BT-EDR(2Mbps)

2480MHz

CSE NdB

08/03/2018

Port1

Ref(Hz)	Ref(dBm)	Limit(dBm)	Freq(Hz)	Level(dBm)	Freq(Hz)	Level(dBm)	Freq(Hz)	Level(dBm)	Freq(Hz)	Level(dBm)	Port
2.480327G	1.99	-18.01	826.832M	-58.60	2.399196G	-58.79	2.483992G	-51.63	6.21165G	-53.08	1

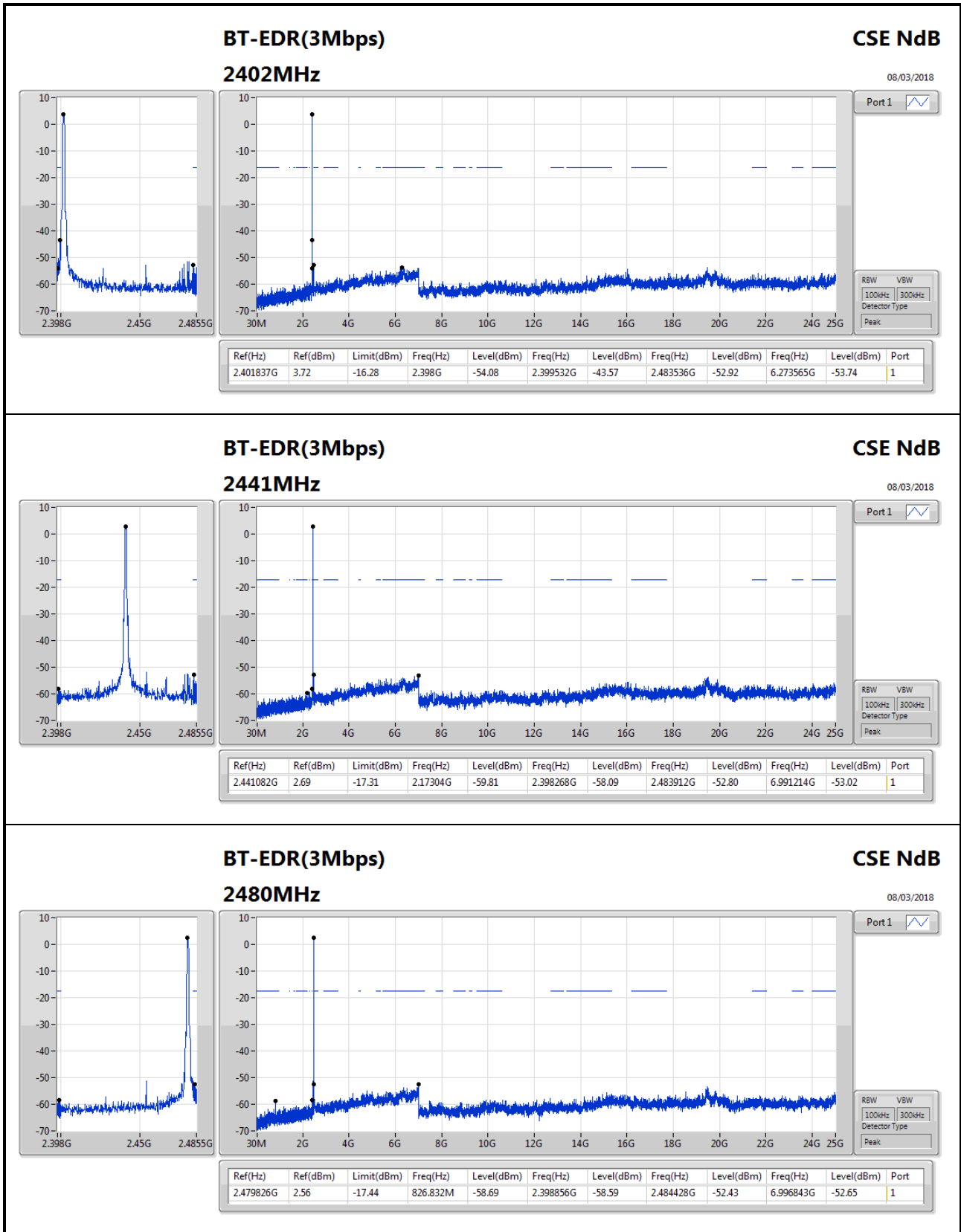



Summary

Mode	Result	Type	Freq (Hz)	Level (dBuV/m)	Limit (dBuV/m)	Margin (dB)	Factor (dB)	Dist (m)	Condition	Azimuth (°)	Height (m)	Comments
2.4-2.4835GHz	-	-	-	-	-	-	-	-	-	-	-	-
BT-BR(1Mbps)	Pass	PK	264.74M	41.38	46.00	-4.62	-5.89	3	Horizontal	0	1.00	-



Result

Mode	Result	Type	Freq (Hz)	Level (dBuV/m)	Limit (dBuV/m)	Margin (dB)	Factor (dB)	Dist (m)	Condition	Azimuth (°)	Height (m)	Comments
BT-BR(1Mbps)	-	-	-	-	-	-	-	-	-	-	-	-
2441MHz	Pass	PK	169.68M	35.44	43.50	-8.06	-9.74	3	Horizontal	0	1.00	-
2441MHz	Pass	PK	198.78M	35.64	43.50	-7.86	-10.04	3	Horizontal	0	1.00	-
2441MHz	Pass	PK	264.74M	41.38	46.00	-4.62	-5.89	3	Horizontal	0	1.00	-
2441MHz	Pass	PK	344.28M	33.44	46.00	-12.56	-4.86	3	Horizontal	0	1.00	-
2441MHz	Pass	PK	388.9M	32.33	46.00	-13.67	-3.91	3	Horizontal	0	1.00	-
2441MHz	Pass	PK	530.52M	32.05	46.00	-13.95	-1.10	3	Horizontal	0	1.00	-
2441MHz	Pass	PK	158.04M	33.36	43.50	-10.14	-9.92	3	Vertical	360	1.00	-
2441MHz	Pass	PK	167.74M	35.13	43.50	-8.37	-9.79	3	Vertical	360	1.00	-
2441MHz	Pass	PK	264.74M	33.40	46.00	-12.60	-5.89	3	Vertical	360	1.00	-
2441MHz	Pass	PK	394.72M	30.21	46.00	-15.79	-3.65	3	Vertical	360	1.00	-
2441MHz	Pass	PK	460.68M	31.30	46.00	-14.70	-2.12	3	Vertical	360	1.00	-
2441MHz	Pass	PK	530.52M	29.66	46.00	-16.34	-1.10	3	Vertical	360	1.00	-



BT-BR(1Mbps)

2441MHz_USB

11/03/2018

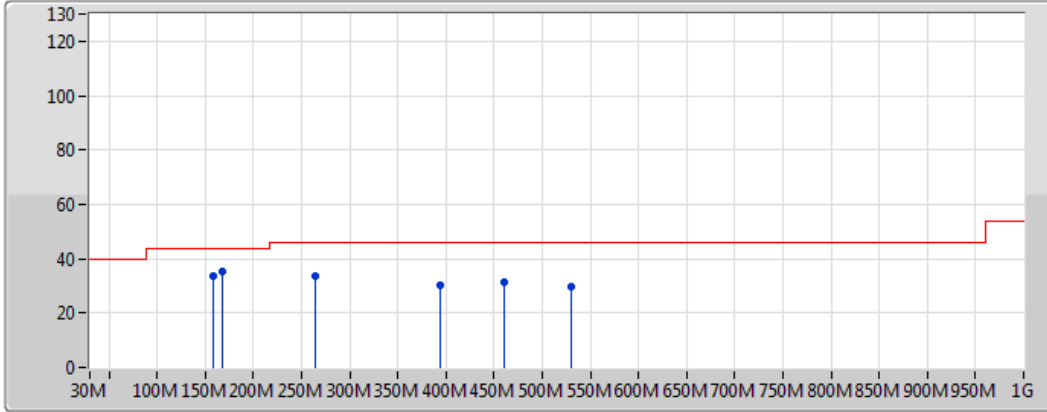

Legend:

- Lim.PK (Red line)
- PK (Blue line)

Type	Freq (Hz)	Level (dBuV/m)	Limit (dBuV/m)	Margin (dB)	Factor (dB)	Dist (m)	Condition	Azimuth (°)	Height (m)	Comments	Raw (dBuV)	AF (dB)	CL (dB)	PA (dB)
PK	158.04M	33.36	43.50	-10.14	-9.92	3	Vertical	360	1.00	-	43.28	15.02	2.16	27.10
PK	167.74M	35.13	43.50	-8.37	-9.79	3	Vertical	360	1.00	-	44.92	14.78	2.49	27.06
PK	264.74M	33.40	46.00	-12.60	-5.89	3	Vertical	360	1.00	-	39.29	18.47	2.40	26.76
PK	394.72M	30.21	46.00	-15.79	-3.65	3	Vertical	360	1.00	-	33.86	20.56	3.05	27.26
PK	460.68M	31.30	46.00	-14.70	-2.12	3	Vertical	360	1.00	-	33.42	22.04	3.45	27.61
PK	530.52M	29.66	46.00	-16.34	-1.10	3	Vertical	360	1.00	-	30.76	23.17	3.61	27.88

BT-BR(1Mbps)

2441MHz_USB

13/03/2018

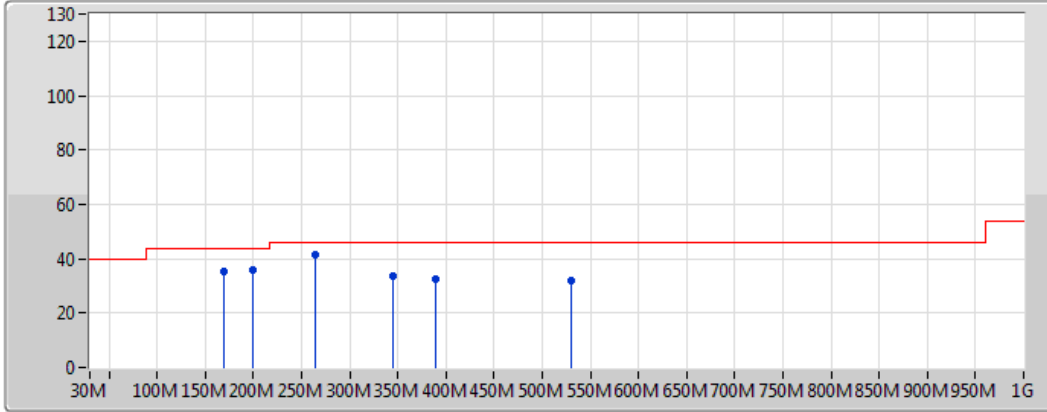

Legend:

- Lim.PK (Red line with square)
- PK (Blue line with square)

Type	Freq (Hz)	Level (dBuV/m)	Limit (dBuV/m)	Margin (dB)	Factor (dB)	Dist (m)	Condition	Azimuth (°)	Height (m)	Comments	Raw (dBuV)	AF (dB)	CL (dB)	PA (dB)
PK	169.68M	35.44	43.50	-8.06	-9.74	3	Horizontal	0	1.00	-	45.18	14.75	2.57	27.05
PK	198.78M	35.64	43.50	-7.86	-10.04	3	Horizontal	0	1.00	-	45.68	14.39	2.48	26.92
PK	264.74M	41.38	46.00	-4.62	-5.89	3	Horizontal	0	1.00	-	47.27	18.47	2.40	26.76
PK	344.28M	33.44	46.00	-12.56	-4.86	3	Horizontal	0	1.00	-	38.30	19.18	2.91	26.95
PK	388.9M	32.33	46.00	-13.67	-3.91	3	Horizontal	0	1.00	-	36.24	20.28	3.04	27.22
PK	530.52M	32.05	46.00	-13.95	-1.10	3	Horizontal	0	1.00	-	33.15	23.17	3.61	27.88



Summary

Mode	Result	Type	Freq (Hz)	Level (dBuV/m)	Limit (dBuV/m)	Margin (dB)	Factor (dB)	Dist (m)	Condition	Azimuth (°)	Height (m)	Comments
2.4-2.4835GHz	-	-	-	-	-	-	-	-	-	-	-	-
BT-BR(1Mbps)	Pass	PK	2.377072G	62.79	74.00	-11.21	30.41	3	Vertical	90	2.59	-
BT-EDR(2Mbps)	Pass	AV	2.483502G	45.65	54.00	-8.35	30.79	3	Vertical	81	2.37	-
BT-EDR(3Mbps)	Pass	AV	2.483502G	45.69	54.00	-8.31	30.79	3	Vertical	81	2.38	-



Result

Mode	Result	Type	Freq (Hz)	Level (dBuV/m)	Limit (dBuV/m)	Margin (dB)	Factor (dB)	Dist (m)	Condition	Azimuth (°)	Height (m)	Comments
BT-BR(1Mbps)	-	-	-	-	-	-	-	-	-	-	-	-
2402MHz	Pass	AV	2.376928G	37.71	54.00	-16.29	30.41	3	Horizontal	106	1.02	-
2402MHz	Pass	AV	2.402G	84.26	Inf	-Inf	30.50	3	Horizontal	106	1.02	-
2402MHz	Pass	PK	2.376928G	60.21	74.00	-13.79	30.41	3	Horizontal	106	1.02	-
2402MHz	Pass	PK	2.402G	106.76	Inf	-Inf	30.50	3	Horizontal	106	1.02	-
2402MHz	Pass	AV	2.377072G	40.29	54.00	-13.71	30.41	3	Vertical	90	2.59	-
2402MHz	Pass	AV	2.402G	87.86	Inf	-Inf	30.50	3	Vertical	90	2.59	-
2402MHz	Pass	PK	2.377072G	62.79	74.00	-11.21	30.41	3	Vertical	90	2.59	-
2402MHz	Pass	PK	2.402G	110.36	Inf	-Inf	30.50	3	Vertical	90	2.59	-
2402MHz	Pass	AV	4.80372G	32.13	54.00	-21.87	5.85	3	Horizontal	202	1.79	-
2402MHz	Pass	PK	4.80372G	54.63	74.00	-19.37	5.85	3	Horizontal	202	1.79	-
2402MHz	Pass	AV	4.804G	35.95	54.00	-18.05	5.85	3	Vertical	183	1.74	-
2402MHz	Pass	PK	4.804G	58.45	74.00	-15.55	5.85	3	Vertical	183	1.74	-
2441MHz	Pass	AV	2.355203G	35.81	54.00	-18.19	30.33	3	Horizontal	99	1.04	-
2441MHz	Pass	AV	2.441G	84.24	Inf	-Inf	30.64	3	Horizontal	99	1.04	-
2441MHz	Pass	AV	2.491435G	36.55	54.00	-17.45	30.82	3	Horizontal	99	1.04	-
2441MHz	Pass	PK	2.355203G	58.31	74.00	-15.69	30.33	3	Horizontal	99	1.04	-
2441MHz	Pass	PK	2.441G	106.74	Inf	-Inf	30.64	3	Horizontal	99	1.04	-
2441MHz	Pass	PK	2.491435G	59.05	74.00	-14.95	30.82	3	Horizontal	99	1.04	-
2441MHz	Pass	AV	2.389696G	35.60	54.00	-18.40	30.45	3	Vertical	90	2.60	-
2441MHz	Pass	AV	2.441G	87.44	Inf	-Inf	30.64	3	Vertical	90	2.60	-
2441MHz	Pass	AV	2.492304G	36.11	54.00	-17.89	30.82	3	Vertical	90	2.60	-
2441MHz	Pass	PK	2.389696G	58.10	74.00	-15.90	30.45	3	Vertical	90	2.60	-
2441MHz	Pass	PK	2.441G	109.94	Inf	-Inf	30.64	3	Vertical	90	2.60	-
2441MHz	Pass	PK	2.492304G	58.61	74.00	-15.39	30.82	3	Vertical	90	2.60	-
2441MHz	Pass	AV	4.88184G	30.57	54.00	-23.43	6.03	3	Horizontal	202	1.72	-
2441MHz	Pass	PK	4.88184G	53.07	74.00	-20.93	6.03	3	Horizontal	202	1.72	-
2441MHz	Pass	AV	4.88224G	30.43	54.00	-23.57	6.03	3	Vertical	176	1.50	-
2441MHz	Pass	PK	4.88224G	52.93	74.00	-21.07	6.03	3	Vertical	176	1.50	-
2480MHz	Pass	AV	2.48G	85.25	Inf	-Inf	30.78	3	Horizontal	106	2.68	-
2480MHz	Pass	AV	2.483502G	37.41	54.00	-16.59	30.79	3	Horizontal	106	2.68	-
2480MHz	Pass	PK	2.48G	107.75	Inf	-Inf	30.78	3	Horizontal	106	2.68	-
2480MHz	Pass	PK	2.483502G	59.91	74.00	-14.09	30.79	3	Horizontal	106	2.68	-
2480MHz	Pass	AV	2.48G	87.39	Inf	-Inf	30.78	3	Vertical	93	2.86	-
2480MHz	Pass	AV	2.489565G	38.51	54.00	-15.49	30.81	3	Vertical	93	2.86	-
2480MHz	Pass	PK	2.48G	109.89	Inf	-Inf	30.78	3	Vertical	93	2.86	-
2480MHz	Pass	PK	2.489565G	61.01	74.00	-12.99	30.81	3	Vertical	93	2.86	-
2480MHz	Pass	AV	4.95974G	34.26	54.00	-19.74	6.21	3	Horizontal	218	1.01	-
2480MHz	Pass	PK	4.95974G	56.76	74.00	-17.24	6.21	3	Horizontal	218	1.01	-
2480MHz	Pass	AV	4.9603G	36.18	54.00	-17.82	6.21	3	Vertical	140	1.63	-
2480MHz	Pass	PK	4.9603G	58.68	74.00	-15.32	6.21	3	Vertical	140	1.63	-
BT-EDR(2Mbps)	-	-	-	-	-	-	-	-	-	-	-	-
2402MHz	Pass	AV	2.387942G	43.25	54.00	-10.75	30.45	3	Horizontal	105	1.20	-
2402MHz	Pass	AV	2.402G	87.11	Inf	-Inf	30.50	3	Horizontal	105	1.20	-
2402MHz	Pass	PK	2.373449G	57.32	74.00	-16.68	30.40	3	Horizontal	105	1.20	-
2402MHz	Pass	PK	2.402145G	102.52	Inf	-Inf	30.50	3	Horizontal	105	1.20	-
2402MHz	Pass	AV	2.389826G	43.46	54.00	-10.54	30.45	3	Vertical	86	2.60	-
2402MHz	Pass	AV	2.402G	90.21	Inf	-Inf	30.50	3	Vertical	86	2.60	-



RSE TX above 1GHz Result

Appendix G.2

Mode	Result	Type	Freq (Hz)	Level (dBuV/m)	Limit (dBuV/m)	Margin (dB)	Factor (dB)	Dist (m)	Condition	Azimuth (°)	Height (m)	Comments
2402MHz	Pass	PK	2.362145G	57.84	74.00	-16.16	30.36	3	Vertical	86	2.60	-
2402MHz	Pass	PK	2.40229G	106.42	Inf	-Inf	30.50	3	Vertical	86	2.60	-
2441MHz	Pass	AV	2.361G	34.98	54.00	-19.02	30.35	3	Horizontal	94	1.06	-
2441MHz	Pass	AV	2.441G	78.50	Inf	-Inf	30.64	3	Horizontal	94	1.06	-
2441MHz	Pass	AV	2.489406G	35.89	54.00	-18.11	30.81	3	Horizontal	94	1.06	-
2441MHz	Pass	PK	2.361G	57.48	74.00	-16.52	30.35	3	Horizontal	94	1.06	-
2441MHz	Pass	PK	2.441G	101.00	Inf	-Inf	30.64	3	Horizontal	94	1.06	-
2441MHz	Pass	PK	2.489406G	58.39	74.00	-15.61	30.81	3	Horizontal	94	1.06	-
2441MHz	Pass	AV	2.376942G	34.96	54.00	-19.04	30.41	3	Vertical	79	2.69	-
2441MHz	Pass	AV	2.44129G	82.70	Inf	-Inf	30.64	3	Vertical	79	2.69	-
2441MHz	Pass	AV	2.488246G	35.33	54.00	-18.67	30.81	3	Vertical	79	2.69	-
2441MHz	Pass	PK	2.376942G	57.46	74.00	-16.54	30.41	3	Vertical	79	2.69	-
2441MHz	Pass	PK	2.44129G	105.20	Inf	-Inf	30.64	3	Vertical	79	2.69	-
2441MHz	Pass	PK	2.488246G	57.83	74.00	-16.17	30.81	3	Vertical	79	2.69	-
2480MHz	Pass	AV	2.48G	87.03	Inf	-Inf	30.78	3	Horizontal	96	1.07	-
2480MHz	Pass	AV	2.483502G	44.84	54.00	-9.16	30.79	3	Horizontal	96	1.07	-
2480MHz	Pass	PK	2.479855G	102.38	Inf	-Inf	30.78	3	Horizontal	96	1.07	-
2480MHz	Pass	PK	2.483768G	58.59	74.00	-15.41	30.79	3	Horizontal	96	1.07	-
2480MHz	Pass	AV	2.48G	89.93	Inf	-Inf	30.78	3	Vertical	81	2.37	-
2480MHz	Pass	AV	2.483502G	45.65	54.00	-8.35	30.79	3	Vertical	81	2.37	-
2480MHz	Pass	PK	2.480145G	106.02	Inf	-Inf	30.78	3	Vertical	81	2.37	-
2480MHz	Pass	PK	2.483768G	60.69	74.00	-13.31	30.79	3	Vertical	81	2.37	-
BT-EDR(3Mbps)	-	-	-	-	-	-	-	-	-	-	-	-
2402MHz	Pass	AV	2.389536G	43.27	54.00	-10.73	30.45	3	Horizontal	102	1.43	-
2402MHz	Pass	AV	2.402G	86.76	Inf	-Inf	30.50	3	Horizontal	102	1.43	-
2402MHz	Pass	PK	2.384319G	57.09	74.00	-16.91	30.44	3	Horizontal	102	1.43	-
2402MHz	Pass	PK	2.402G	102.41	Inf	-Inf	30.50	3	Horizontal	102	1.43	-
2402MHz	Pass	AV	2.389971G	43.64	54.00	-10.36	30.45	3	Vertical	81	2.56	-
2402MHz	Pass	AV	2.402G	90.54	Inf	-Inf	30.50	3	Vertical	81	2.56	-
2402MHz	Pass	PK	2.389536G	57.17	74.00	-16.83	30.45	3	Vertical	81	2.56	-
2402MHz	Pass	PK	2.402G	107.16	Inf	-Inf	30.50	3	Vertical	81	2.56	-
2441MHz	Pass	AV	2.387957G	34.68	54.00	-19.32	30.45	3	Horizontal	97	1.24	-
2441MHz	Pass	AV	2.441G	78.29	Inf	-Inf	30.64	3	Horizontal	97	1.24	-
2441MHz	Pass	AV	2.494043G	35.55	54.00	-18.44	30.82	3	Horizontal	97	1.24	-
2441MHz	Pass	PK	2.387957G	57.18	74.00	-16.82	30.45	3	Horizontal	97	1.24	-
2441MHz	Pass	PK	2.441G	100.79	Inf	-Inf	30.64	3	Horizontal	97	1.24	-
2441MHz	Pass	PK	2.494043G	58.05	74.00	-15.95	30.82	3	Horizontal	97	1.24	-
2441MHz	Pass	AV	2.356072G	34.19	54.00	-19.81	30.34	3	Vertical	82	2.70	-
2441MHz	Pass	AV	2.441G	83.11	Inf	-Inf	30.64	3	Vertical	82	2.70	-
2441MHz	Pass	AV	2.497812G	35.32	54.00	-18.68	30.84	3	Vertical	82	2.70	-
2441MHz	Pass	PK	2.356072G	56.69	74.00	-17.31	30.34	3	Vertical	82	2.70	-
2441MHz	Pass	PK	2.441G	105.61	Inf	-Inf	30.64	3	Vertical	82	2.70	-
2441MHz	Pass	PK	2.497812G	57.82	74.00	-16.18	30.84	3	Vertical	82	2.70	-
2480MHz	Pass	AV	2.48G	86.99	Inf	-Inf	30.78	3	Horizontal	97	1.08	-
2480MHz	Pass	AV	2.483502G	44.89	54.00	-9.11	30.79	3	Horizontal	97	1.08	-
2480MHz	Pass	PK	2.48G	102.76	Inf	-Inf	30.78	3	Horizontal	97	1.08	-
2480MHz	Pass	PK	2.489565G	58.39	74.00	-15.61	30.81	3	Horizontal	97	1.08	-
2480MHz	Pass	AV	2.48G	89.76	Inf	-Inf	30.78	3	Vertical	81	2.38	-
2480MHz	Pass	AV	2.483502G	45.69	54.00	-8.31	30.79	3	Vertical	81	2.38	-



RSE TX above 1GHz Result

Appendix G.2

Mode	Result	Type	Freq (Hz)	Level (dBuV/m)	Limit (dBuV/m)	Margin (dB)	Factor (dB)	Dist (m)	Condition	Azimuth (°)	Height (m)	Comments
2480MHz	Pass	PK	2.48G	106.30	Inf	-Inf	30.78	3	Vertical	81	2.38	-
2480MHz	Pass	PK	2.484348G	59.54	74.00	-14.46	30.79	3	Vertical	81	2.38	-

BT-BR(1Mbps)

2402MHz_TX

11/03/2018

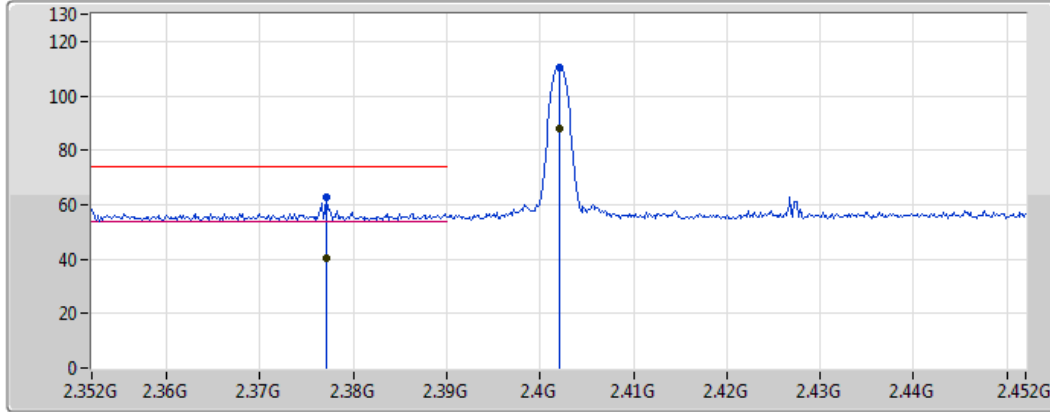

Legend for the spectrum plot:

- Lim.PK: Red line with a peak icon
- PK: Blue line with a peak icon
- Lim.AV: Red line with a valley icon
- AV: Blue line with a valley icon

Type	Freq (Hz)	Level (dBuV/m)	Limit (dBuV/m)	Margin (dB)	Factor (dB)	Dist (m)	Condition	Azimuth (°)	Height (m)	Comments	Raw (dBuV)	AF (dB)	CL (dB)	PA (dB)
AV	2.377072G	40.29	54.00	-13.71	30.41	3	Vertical	90	2.59	-	9.88	27.18	3.23	-
AV	2.402G	87.86	Inf	-Inf	30.50	3	Vertical	90	2.59	-	57.36	27.25	3.25	-
PK	2.377072G	62.79	74.00	-11.21	30.41	3	Vertical	90	2.59	-	32.38	27.18	3.23	-
PK	2.402G	110.36	Inf	-Inf	30.50	3	Vertical	90	2.59	-	79.86	27.25	3.25	-



BT-BR(1Mbps)

2402MHz_TX

11/03/2018

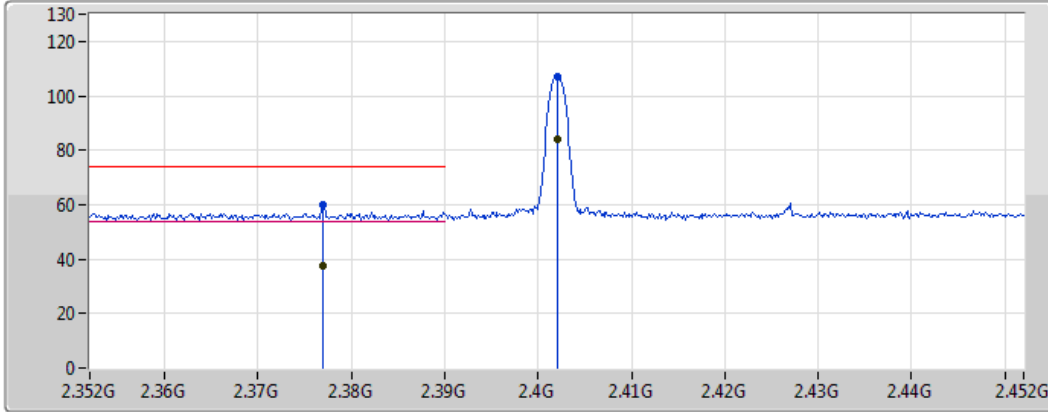

Type	Freq (Hz)	Level (dBuV/m)	Limit (dBuV/m)	Margin (dB)	Factor (dB)	Dist (m)	Condition	Azimuth (°)	Height (m)	Comments	Raw (dBuV)	AF (dB)	CL (dB)	PA (dB)
AV	2.376928G	37.71	54.00	-16.29	30.41	3	Horizontal	106	1.02	-	7.30	27.18	3.23	-
AV	2.402G	84.26	Inf	-Inf	30.50	3	Horizontal	106	1.02	-	53.76	27.25	3.25	-
PK	2.376928G	60.21	74.00	-13.79	30.41	3	Horizontal	106	1.02	-	29.80	27.18	3.23	-
PK	2.402G	106.76	Inf	-Inf	30.50	3	Horizontal	106	1.02	-	76.26	27.25	3.25	-



BT-BR(1Mbps)

2402MHz_TX

11/03/2018

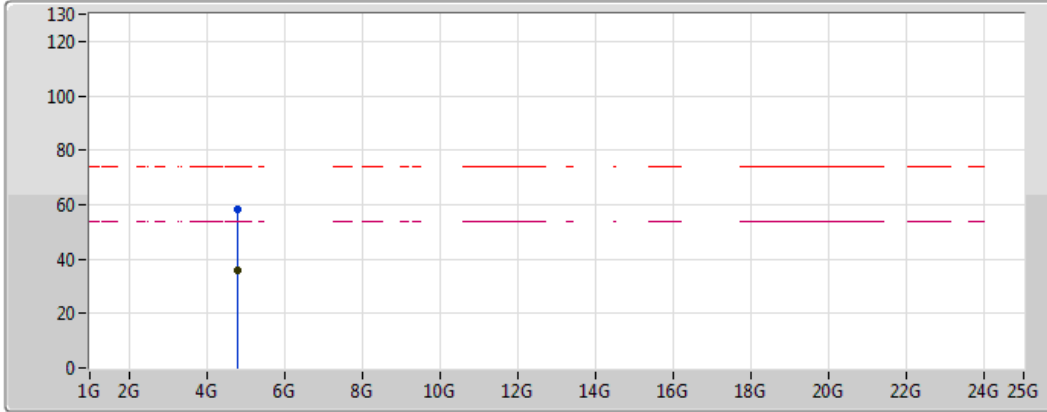

Lim.PK	
PK	
Lim.AV	
AV	

Type	Freq (Hz)	Level (dBuV/m)	Limit (dBuV/m)	Margin (dB)	Factor (dB)	Dist (m)	Condition	Azimuth (°)	Height (m)	Comments	Raw (dBuV)	AF (dB)	CL (dB)	PA (dB)
AV	4.804G	35.95	54.00	-18.05	5.85	3	Vertical	183	1.74	-	30.10	31.19	4.51	29.85
PK	4.804G	58.45	74.00	-15.55	5.85	3	Vertical	183	1.74	-	52.60	31.19	4.51	29.85



BT-BR(1Mbps)

2402MHz_TX

11/03/2018

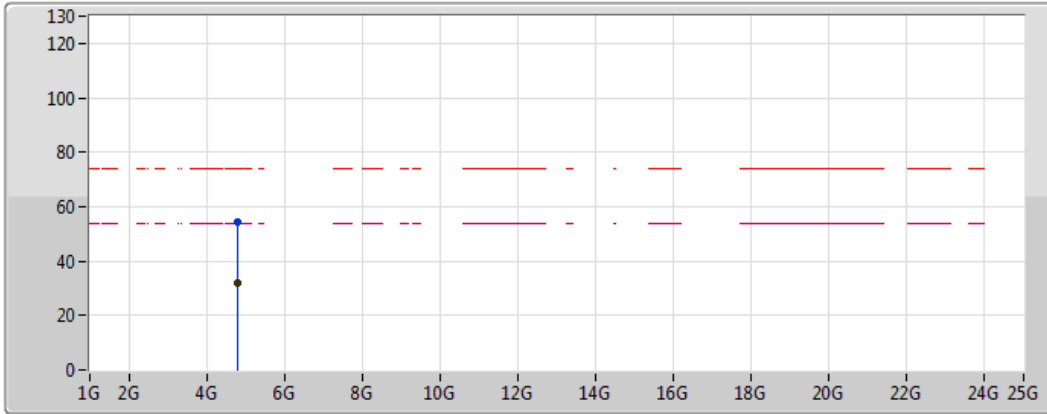

Legend for the spectrum plot:

- Lim.PK: Red dashed line with a peak icon
- PK: Blue dashed line with a peak icon
- Lim.AV: Magenta dashed line with a peak icon
- AV: Green dashed line with a peak icon

Type	Freq (Hz)	Level (dBuV/m)	Limit (dBuV/m)	Margin (dB)	Factor (dB)	Dist (m)	Condition	Azimuth (°)	Height (m)	Comments	Raw (dBuV)	AF (dB)	CL (dB)	PA (dB)
AV	4.80372G	32.13	54.00	-21.87	5.85	3	Horizontal	202	1.79	-	26.28	31.19	4.51	29.85
PK	4.80372G	54.63	74.00	-19.37	5.85	3	Horizontal	202	1.79	-	48.78	31.19	4.51	29.85



BT-BR(1Mbps)

2441MHz_TX

11/03/2018

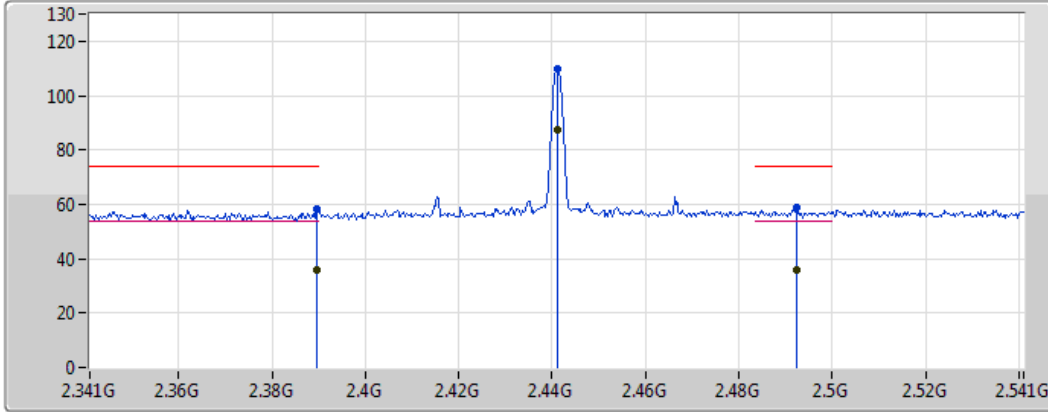

Type	Freq (Hz)	Level (dBuV/m)	Limit (dBuV/m)	Margin (dB)	Factor (dB)	Dist (m)	Condition	Azimuth (°)	Height (m)	Comments	Raw (dBuV)	AF (dB)	CL (dB)	PA (dB)
AV	2.389696G	35.60	54.00	-18.40	30.45	3	Vertical	90	2.60	-	5.15	27.21	3.24	-
AV	2.441G	87.44	Inf	-Inf	30.64	3	Vertical	90	2.60	-	56.80	27.35	3.29	-
AV	2.492304G	36.11	54.00	-17.89	30.82	3	Vertical	90	2.60	-	5.29	27.48	3.34	-
PK	2.389696G	58.10	74.00	-15.90	30.45	3	Vertical	90	2.60	-	27.65	27.21	3.24	-
PK	2.441G	109.94	Inf	-Inf	30.64	3	Vertical	90	2.60	-	79.30	27.35	3.29	-
PK	2.492304G	58.61	74.00	-15.39	30.82	3	Vertical	90	2.60	-	27.79	27.48	3.34	-

BT-BR(1Mbps)

2441MHz_TX

11/03/2018

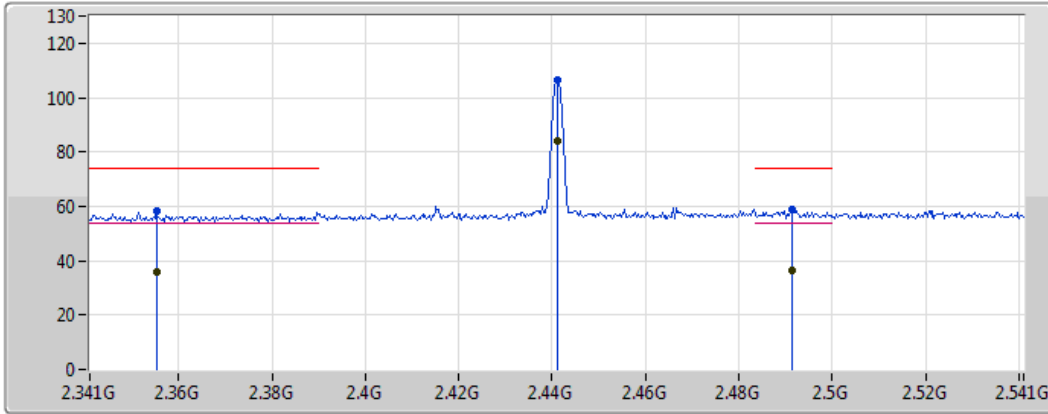





Type	Freq (Hz)	Level (dBuV/m)	Limit (dBuV/m)	Margin (dB)	Factor (dB)	Dist (m)	Condition	Azimuth (°)	Height (m)	Comments	Raw (dBuV)	AF (dB)	CL (dB)	PA (dB)
AV	2.355203G	35.81	54.00	-18.19	30.33	3	Horizontal	99	1.04	-	5.48	27.12	3.21	-
AV	2.441G	84.24	Inf	-Inf	30.64	3	Horizontal	99	1.04	-	53.60	27.35	3.29	-
AV	2.491435G	36.55	54.00	-17.45	30.82	3	Horizontal	99	1.04	-	5.73	27.48	3.34	-
PK	2.355203G	58.31	74.00	-15.69	30.33	3	Horizontal	99	1.04	-	27.98	27.12	3.21	-
PK	2.441G	106.74	Inf	-Inf	30.64	3	Horizontal	99	1.04	-	76.10	27.35	3.29	-
PK	2.491435G	59.05	74.00	-14.95	30.82	3	Horizontal	99	1.04	-	28.23	27.48	3.34	-

BT-BR(1Mbps)

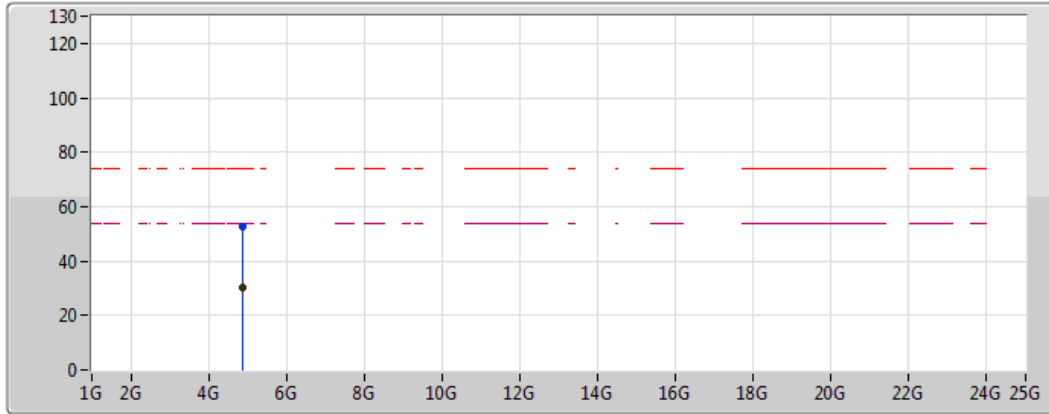
2441MHz_TX

11/03/2018



Lim.PK	
PK	
Lim.AV	
AV	

Type	Freq (Hz)	Level (dBuV/m)	Limit (dBuV/m)	Margin (dB)	Factor (dB)	Dist (m)	Condition	Azimuth (°)	Height (m)	Comments	Raw (dBuV)	AF (dB)	CL (dB)	PA (dB)
AV	4.88224G	30.43	54.00	-23.57	6.03	3	Vertical	176	1.50	-	24.40	31.31	4.55	29.83
PK	4.88224G	52.93	74.00	-21.07	6.03	3	Vertical	176	1.50	-	46.90	31.31	4.55	29.83

BT-BR(1Mbps)

2441MHz_TX

11/03/2018

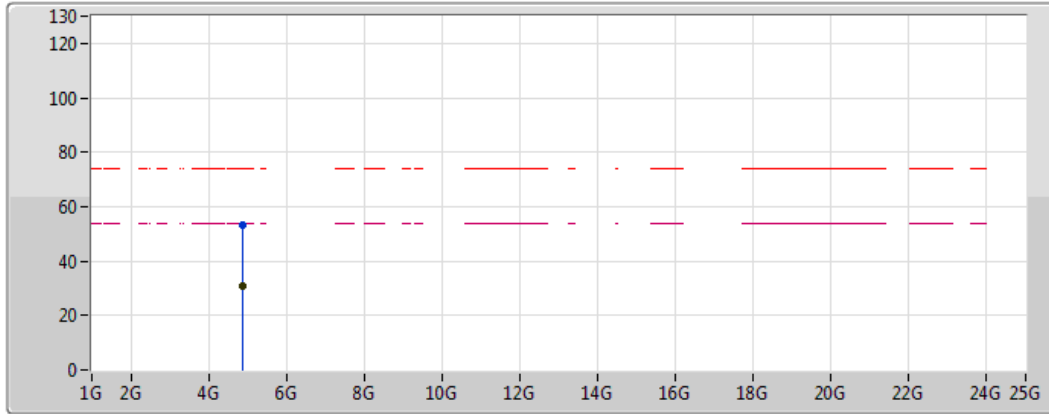

Type	Freq (Hz)	Level (dBuV/m)	Limit (dBuV/m)	Margin (dB)	Factor (dB)	Dist (m)	Condition	Azimuth (°)	Height (m)	Comments	Raw (dBuV)	AF (dB)	CL (dB)	PA (dB)
AV	4.88184G	30.57	54.00	-23.43	6.03	3	Horizontal	202	1.72	-	24.54	31.31	4.55	29.83
PK	4.88184G	53.07	74.00	-20.93	6.03	3	Horizontal	202	1.72	-	47.04	31.31	4.55	29.83



BT-BR(1Mbps)

2480MHz_TX

11/03/2018

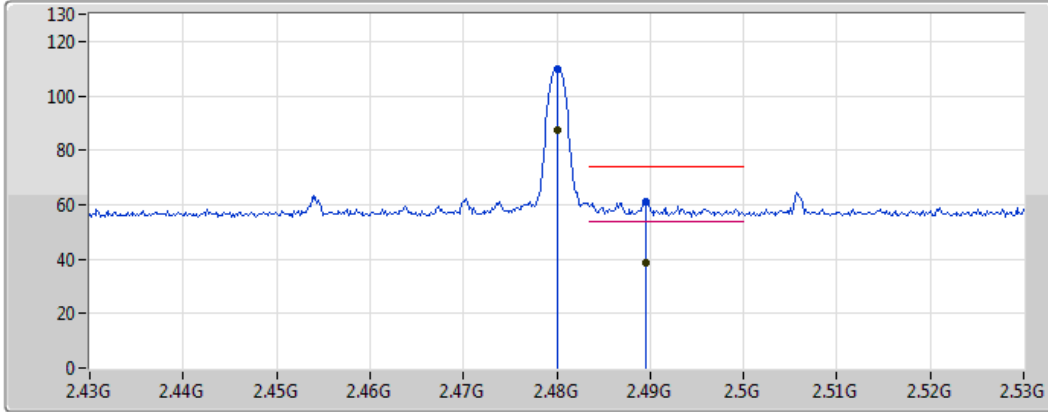

Type	Freq (Hz)	Level (dBuV/m)	Limit (dBuV/m)	Margin (dB)	Factor (dB)	Dist (m)	Condition	Azimuth (°)	Height (m)	Comments	Raw (dBuV)	AF (dB)	CL (dB)	PA (dB)
AV	2.48G	87.39	Inf	-Inf	30.78	3	Vertical	93	2.86	-	56.61	27.45	3.33	-
AV	2.489565G	38.51	54.00	-15.49	30.81	3	Vertical	93	2.86	-	7.70	27.47	3.34	-
PK	2.48G	109.89	Inf	-Inf	30.78	3	Vertical	93	2.86	-	79.11	27.45	3.33	-
PK	2.489565G	61.01	74.00	-12.99	30.81	3	Vertical	93	2.86	-	30.20	27.47	3.34	-



BT-BR(1Mbps)

2480MHz_TX

11/03/2018

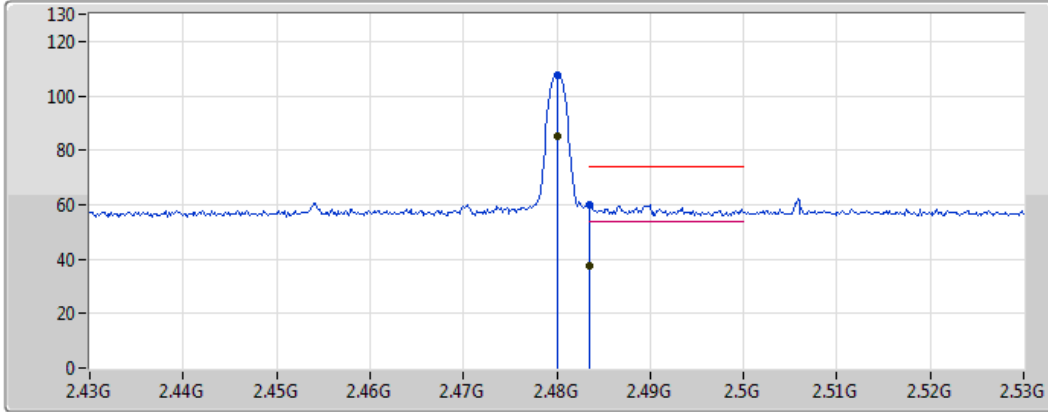

Legend for plot:

- Lim.PK
- PK
- Lim.AV
- AV





Type	Freq (Hz)	Level (dBuV/m)	Limit (dBuV/m)	Margin (dB)	Factor (dB)	Dist (m)	Condition	Azimuth (°)	Height (m)	Comments	Raw (dBuV)	AF (dB)	CL (dB)	PA (dB)
AV	2.48G	85.25	Inf	-Inf	30.78	3	Horizontal	106	2.68	-	54.47	27.45	3.33	-
AV	2.483502G	37.41	54.00	-16.59	30.79	3	Horizontal	106	2.68	-	6.62	27.46	3.33	-
PK	2.48G	107.75	Inf	-Inf	30.78	3	Horizontal	106	2.68	-	76.97	27.45	3.33	-
PK	2.483502G	59.91	74.00	-14.09	30.79	3	Horizontal	106	2.68	-	29.12	27.46	3.33	-

BT-BR(1Mbps)

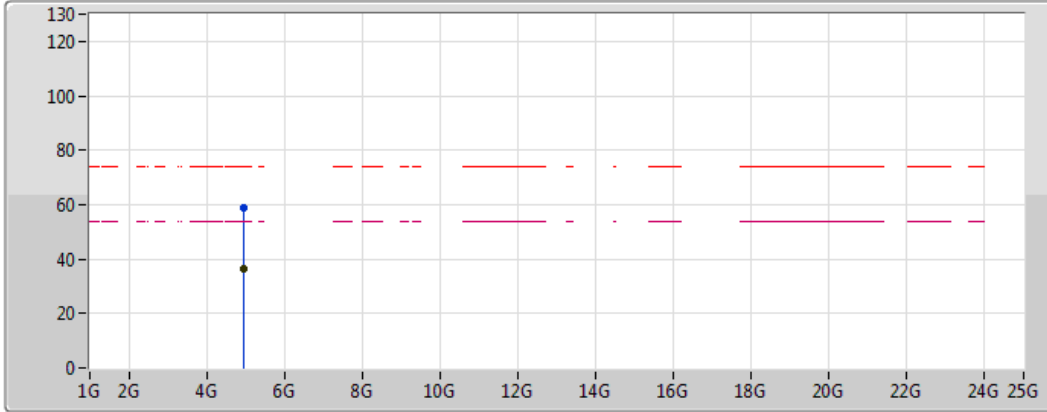
2480MHz_TX

11/03/2018



Lim.PK	
PK	
Lim.AV	
AV	

Type	Freq (Hz)	Level (dBuV/m)	Limit (dBuV/m)	Margin (dB)	Factor (dB)	Dist (m)	Condition	Azimuth (°)	Height (m)	Comments	Raw (dBuV)	AF (dB)	CL (dB)	PA (dB)
AV	4.9603G	36.18	54.00	-17.82	6.21	3	Vertical	140	1.63	-	29.97	31.44	4.59	29.82
PK	4.9603G	58.68	74.00	-15.32	6.21	3	Vertical	140	1.63	-	52.47	31.44	4.59	29.82

BT-BR(1Mbps)

2480MHz_TX

11/03/2018

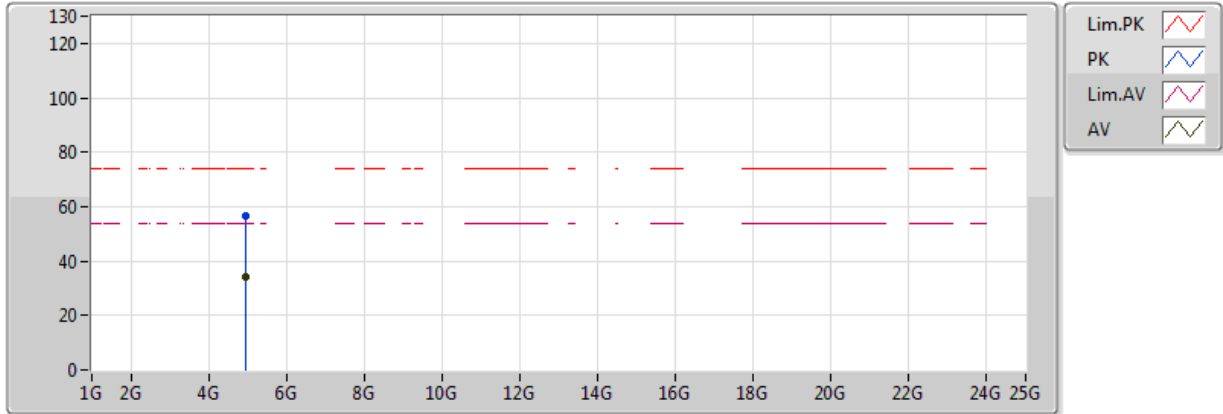

Type	Freq (Hz)	Level (dBuV/m)	Limit (dBuV/m)	Margin (dB)	Factor (dB)	Dist (m)	Condition	Azimuth (°)	Height (m)	Comments	Raw (dBuV)	AF (dB)	CL (dB)	PA (dB)
AV	4.95974G	34.26	54.00	-19.74	6.21	3	Horizontal	218	1.01	-	28.05	31.44	4.59	29.82
PK	4.95974G	56.76	74.00	-17.24	6.21	3	Horizontal	218	1.01	-	50.55	31.44	4.59	29.82

BT-EDR(2Mbps)

2402MHz_TX

11/03/2018

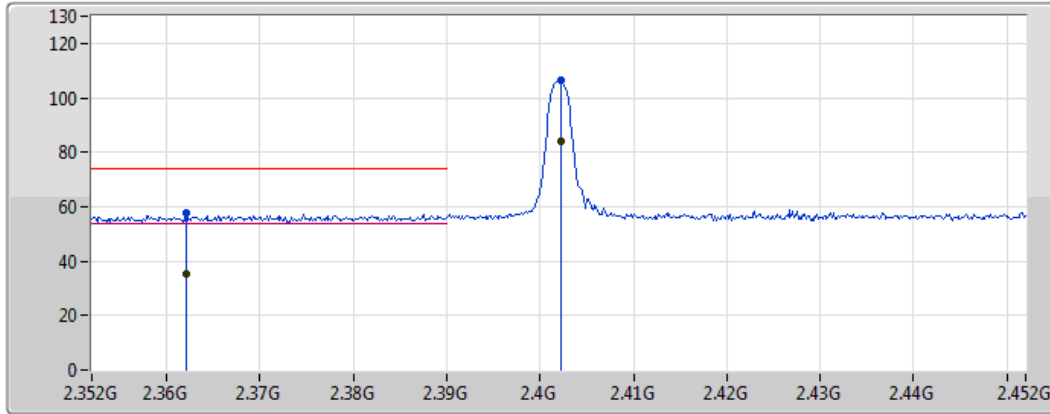

Type	Freq (Hz)	Level (dBuV/m)	Limit (dBuV/m)	Margin (dB)	Factor (dB)	Dist (m)	Condition	Azimuth (°)	Height (m)	Comments	Raw (dBuV)	AF (dB)	CL (dB)	PA (dB)
AV	2.362145G	35.34	54.00	-18.66	30.36	3	Vertical	86	2.60	-	4.98	27.14	3.22	-
AV	2.40229G	83.92	Inf	-Inf	30.50	3	Vertical	86	2.60	-	53.42	27.25	3.25	-
PK	2.362145G	57.84	74.00	-16.16	30.36	3	Vertical	86	2.60	-	27.48	27.14	3.22	-
PK	2.40229G	106.42	Inf	-Inf	30.50	3	Vertical	86	2.60	-	75.92	27.25	3.25	-



BT-EDR(2Mbps)

2402MHz_TX

11/03/2018

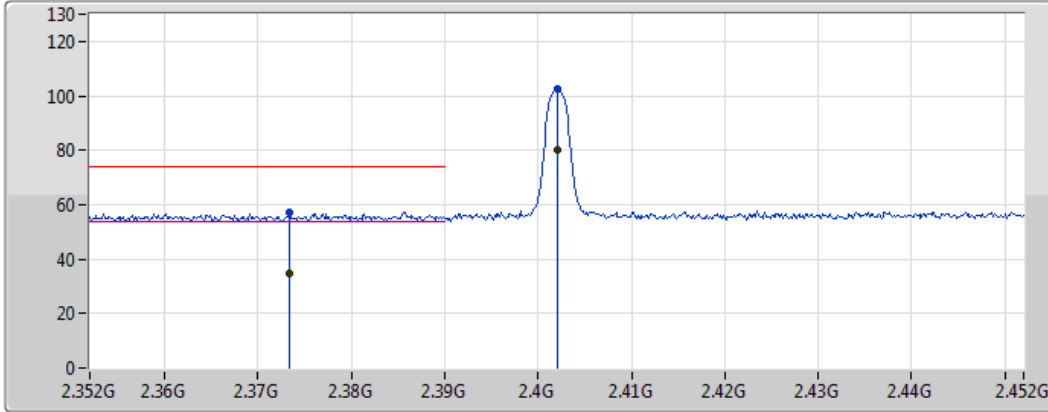

Type	Freq (Hz)	Level (dBuV/m)	Limit (dBuV/m)	Margin (dB)	Factor (dB)	Dist (m)	Condition	Azimuth (°)	Height (m)	Comments	Raw (dBuV)	AF (dB)	CL (dB)	PA (dB)
AV	2.373449G	34.82	54.00	-19.18	30.40	3	Horizontal	105	1.20	-	4.42	27.17	3.23	-
AV	2.402145G	80.02	Inf	-Inf	30.50	3	Horizontal	105	1.20	-	49.52	27.25	3.25	-
PK	2.373449G	57.32	74.00	-16.68	30.40	3	Horizontal	105	1.20	-	26.92	27.17	3.23	-
PK	2.402145G	102.52	Inf	-Inf	30.50	3	Horizontal	105	1.20	-	72.02	27.25	3.25	-



BT-EDR(2Mbps)

2441MHz_TX

11/03/2018

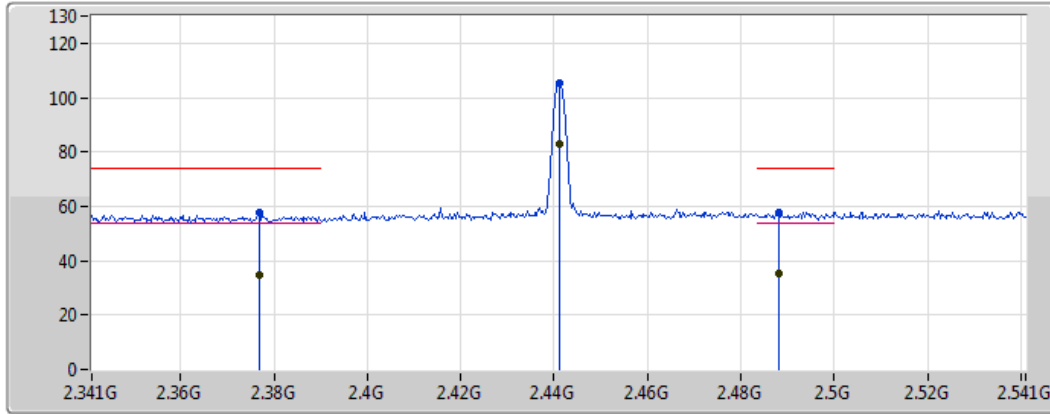

Type	Freq (Hz)	Level (dBuV/m)	Limit (dBuV/m)	Margin (dB)	Factor (dB)	Dist (m)	Condition	Azimuth (°)	Height (m)	Comments	Raw (dBuV)	AF (dB)	CL (dB)	PA (dB)
AV	2.376942G	34.96	54.00	-19.04	30.41	3	Vertical	79	2.69	-	4.55	27.18	3.23	-
AV	2.44129G	82.70	Inf	-Inf	30.64	3	Vertical	79	2.69	-	52.06	27.35	3.29	-
AV	2.488246G	35.33	54.00	-18.67	30.81	3	Vertical	79	2.69	-	4.52	27.47	3.34	-
PK	2.376942G	57.46	74.00	-16.54	30.41	3	Vertical	79	2.69	-	27.05	27.18	3.23	-
PK	2.44129G	105.20	Inf	-Inf	30.64	3	Vertical	79	2.69	-	74.56	27.35	3.29	-
PK	2.488246G	57.83	74.00	-16.17	30.81	3	Vertical	79	2.69	-	27.02	27.47	3.34	-



BT-EDR(2Mbps)

2441MHz_TX

11/03/2018

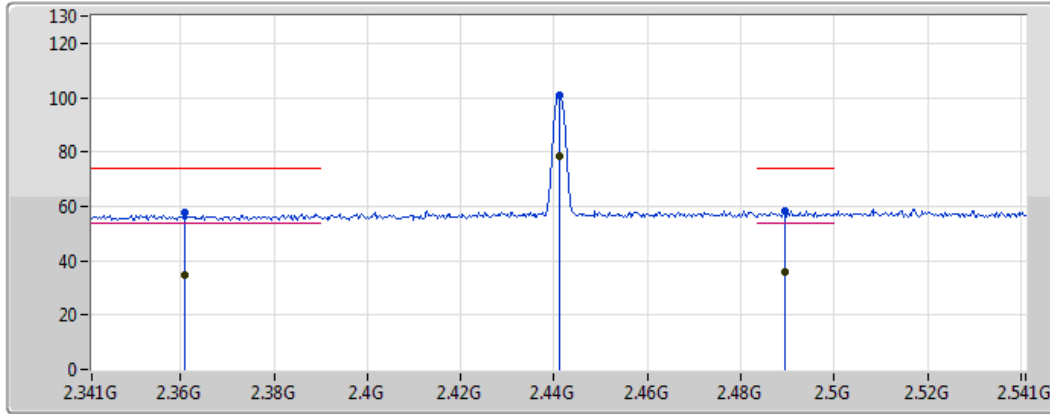

Lim.PK	
PK	
Lim.AV	
AV	

Type	Freq (Hz)	Level (dBuV/m)	Limit (dBuV/m)	Margin (dB)	Factor (dB)	Dist (m)	Condition	Azimuth (°)	Height (m)	Comments	Raw (dBuV)	AF (dB)	CL (dB)	PA (dB)
AV	2.361G	34.98	54.00	-19.02	30.35	3	Horizontal	94	1.06	-	4.63	27.14	3.21	-
AV	2.441G	78.50	Inf	-Inf	30.64	3	Horizontal	94	1.06	-	47.86	27.35	3.29	-
AV	2.489406G	35.89	54.00	-18.11	30.81	3	Horizontal	94	1.06	-	5.08	27.47	3.34	-
PK	2.361G	57.48	74.00	-16.52	30.35	3	Horizontal	94	1.06	-	27.13	27.14	3.21	-
PK	2.441G	101.00	Inf	-Inf	30.64	3	Horizontal	94	1.06	-	70.36	27.35	3.29	-
PK	2.489406G	58.39	74.00	-15.61	30.81	3	Horizontal	94	1.06	-	27.58	27.47	3.34	-

BT-EDR(2Mbps)

2480MHz_TX

11/03/2018

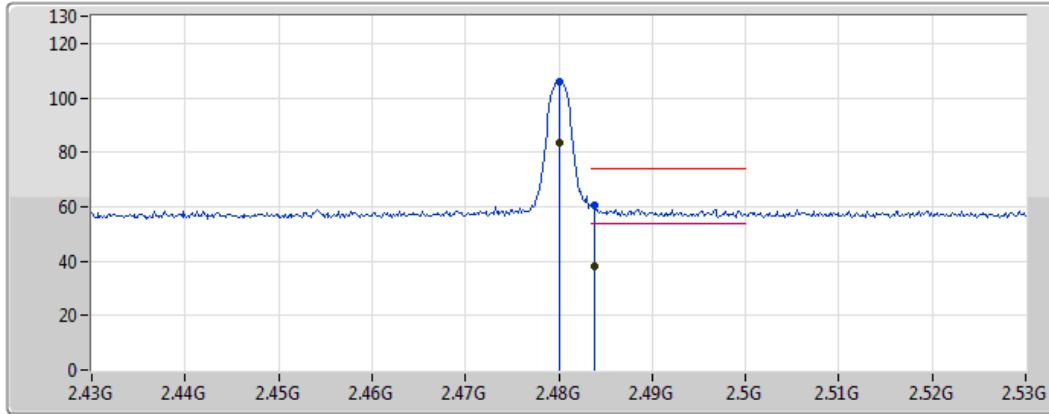

Type	Freq (Hz)	Level (dBuV/m)	Limit (dBuV/m)	Margin (dB)	Factor (dB)	Dist (m)	Condition	Azimuth (°)	Height (m)	Comments	Raw (dBuV)	AF (dB)	CL (dB)	PA (dB)
AV	2.480145G	83.52	Inf	-Inf	30.78	3	Vertical	81	2.37	-	52.74	27.45	3.33	-
AV	2.483768G	38.19	54.00	-15.81	30.79	3	Vertical	81	2.37	-	7.40	27.46	3.33	-
PK	2.480145G	106.02	Inf	-Inf	30.78	3	Vertical	81	2.37	-	75.24	27.45	3.33	-
PK	2.483768G	60.69	74.00	-13.31	30.79	3	Vertical	81	2.37	-	29.90	27.46	3.33	-

BT-EDR(2Mbps)

2480MHz_TX

11/03/2018

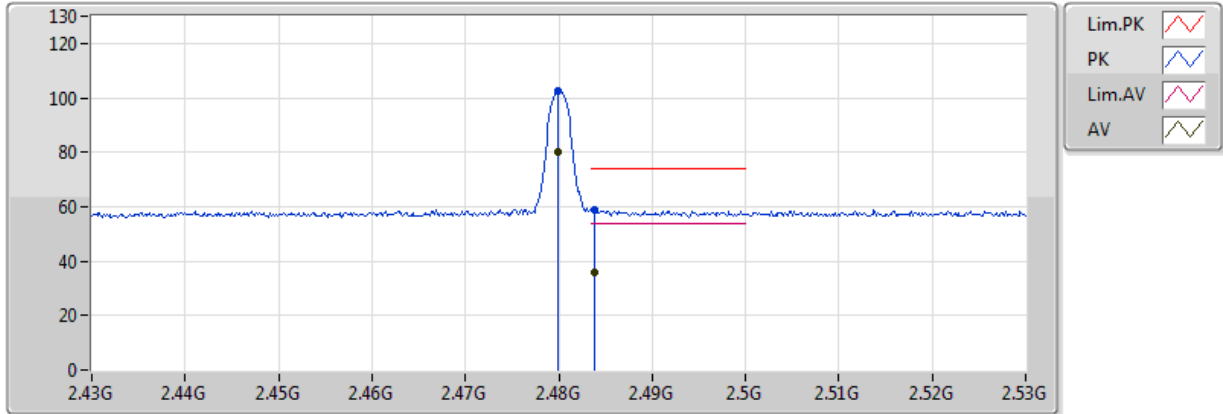

Type	Freq (Hz)	Level (dBuV/m)	Limit (dBuV/m)	Margin (dB)	Factor (dB)	Dist (m)	Condition	Azimuth (°)	Height (m)	Comments	Raw (dBuV)	AF (dB)	CL (dB)	PA (dB)
AV	2.479855G	79.88	Inf	-Inf	30.78	3	Horizontal	96	1.07	-	49.10	27.45	3.33	-
AV	2.483768G	36.09	54.00	-17.91	30.79	3	Horizontal	96	1.07	-	5.30	27.46	3.33	-
PK	2.479855G	102.38	Inf	-Inf	30.78	3	Horizontal	96	1.07	-	71.60	27.45	3.33	-
PK	2.483768G	58.59	74.00	-15.41	30.79	3	Horizontal	96	1.07	-	27.80	27.46	3.33	-

BT-EDR(3Mbps)

2402MHz_TX

11/03/2018

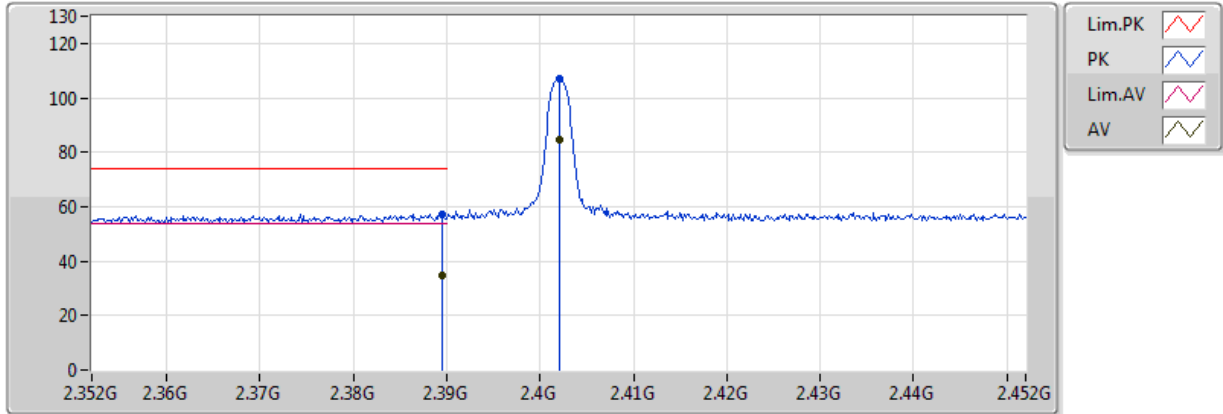

Type	Freq (Hz)	Level (dBuV/m)	Limit (dBuV/m)	Margin (dB)	Factor (dB)	Dist (m)	Condition	Azimuth (°)	Height (m)	Comments	Raw (dBuV)	AF (dB)	CL (dB)	PA (dB)
AV	2.389536G	34.67	54.00	-19.33	30.45	3	Vertical	81	2.56	-	4.22	27.21	3.24	-
AV	2.402G	84.66	Inf	-Inf	30.50	3	Vertical	81	2.56	-	54.16	27.25	3.25	-
PK	2.389536G	57.17	74.00	-16.83	30.45	3	Vertical	81	2.56	-	26.72	27.21	3.24	-
PK	2.402G	107.16	Inf	-Inf	30.50	3	Vertical	81	2.56	-	76.66	27.25	3.25	-

BT-EDR(3Mbps)

2402MHz_TX

11/03/2018

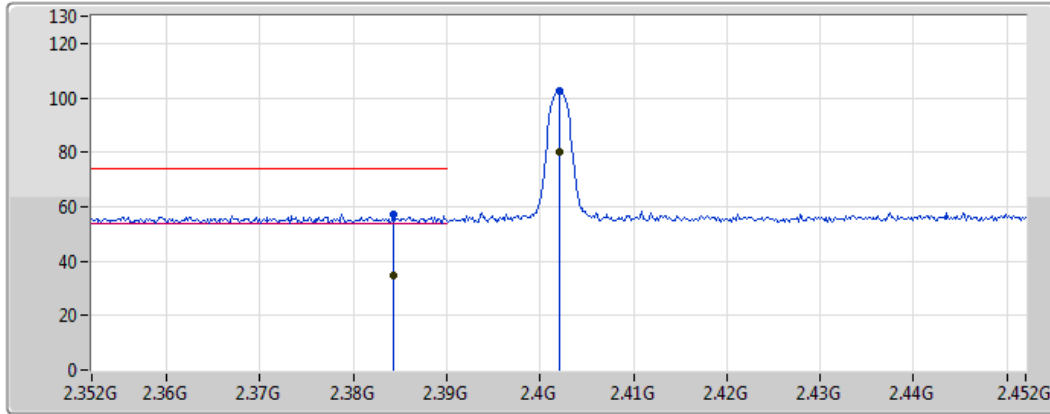

Legend for plot:

- Lim.PK (Red line)
- PK (Blue line)
- Lim.AV (Pink line)
- AV (Green line)

Type	Freq (Hz)	Level (dBuV/m)	Limit (dBuV/m)	Margin (dB)	Factor (dB)	Dist (m)	Condition	Azimuth (°)	Height (m)	Comments	Raw (dBuV)	AF (dB)	CL (dB)	PA (dB)
AV	2.384319G	34.59	54.00	-19.41	30.44	3	Horizontal	102	1.43	-	4.15	27.20	3.24	-
AV	2.402G	79.91	Inf	-Inf	30.50	3	Horizontal	102	1.43	-	49.41	27.25	3.25	-
PK	2.384319G	57.09	74.00	-16.91	30.44	3	Horizontal	102	1.43	-	26.65	27.20	3.24	-
PK	2.402G	102.41	Inf	-Inf	30.50	3	Horizontal	102	1.43	-	71.91	27.25	3.25	-

BT-EDR(3Mbps)

2441MHz_TX

11/03/2018

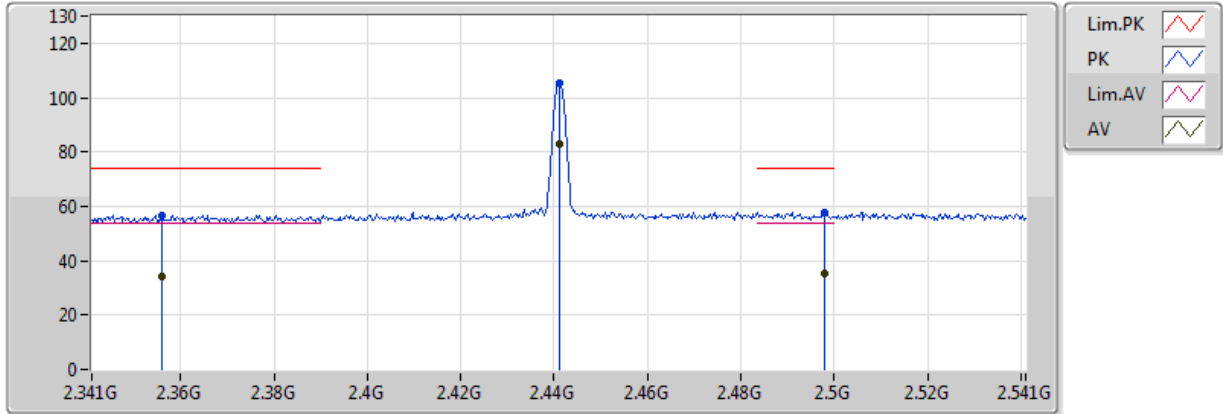





Type	Freq (Hz)	Level (dBuV/m)	Limit (dBuV/m)	Margin (dB)	Factor (dB)	Dist (m)	Condition	Azimuth (°)	Height (m)	Comments	Raw (dBuV)	AF (dB)	CL (dB)	PA (dB)
AV	2.356072G	34.19	54.00	-19.81	30.34	3	Vertical	82	2.70	-	3.85	27.13	3.21	-
AV	2.441G	83.11	Inf	-Inf	30.64	3	Vertical	82	2.70	-	52.47	27.35	3.29	-
AV	2.497812G	35.32	54.00	-18.68	30.84	3	Vertical	82	2.70	-	4.48	27.49	3.35	-
PK	2.356072G	56.69	74.00	-17.31	30.34	3	Vertical	82	2.70	-	26.35	27.13	3.21	-
PK	2.441G	105.61	Inf	-Inf	30.64	3	Vertical	82	2.70	-	74.97	27.35	3.29	-
PK	2.497812G	57.82	74.00	-16.18	30.84	3	Vertical	82	2.70	-	26.98	27.49	3.35	-

BT-EDR(3Mbps)

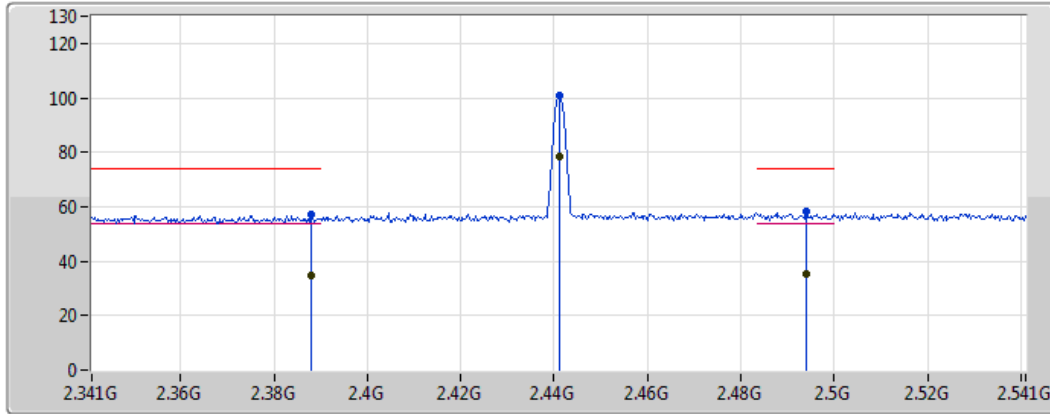
2441MHz_TX

13/03/2018



Lim.PK	
PK	
Lim.AV	
AV	

Type	Freq (Hz)	Level (dBuV/m)	Limit (dBuV/m)	Margin (dB)	Factor (dB)	Dist (m)	Condition	Azimuth (°)	Height (m)	Comments	Raw (dBuV)	AF (dB)	CL (dB)	PA (dB)
AV	2.387957G	34.68	54.00	-19.32	30.45	3	Horizontal	97	1.24	-	4.23	27.21	3.24	-
AV	2.441G	78.29	Inf	-Inf	30.64	3	Horizontal	97	1.24	-	47.65	27.35	3.29	-
AV	2.494043G	35.55	54.00	-18.44	30.82	3	Horizontal	97	1.24	-	4.73	27.48	3.34	-
PK	2.387957G	57.18	74.00	-16.82	30.45	3	Horizontal	97	1.24	-	26.73	27.21	3.24	-
PK	2.441G	100.79	Inf	-Inf	30.64	3	Horizontal	97	1.24	-	70.15	27.35	3.29	-
PK	2.494043G	58.05	74.00	-15.95	30.82	3	Horizontal	97	1.24	-	27.23	27.48	3.34	-

BT-EDR(3Mbps)

2480MHz_TX

11/03/2018

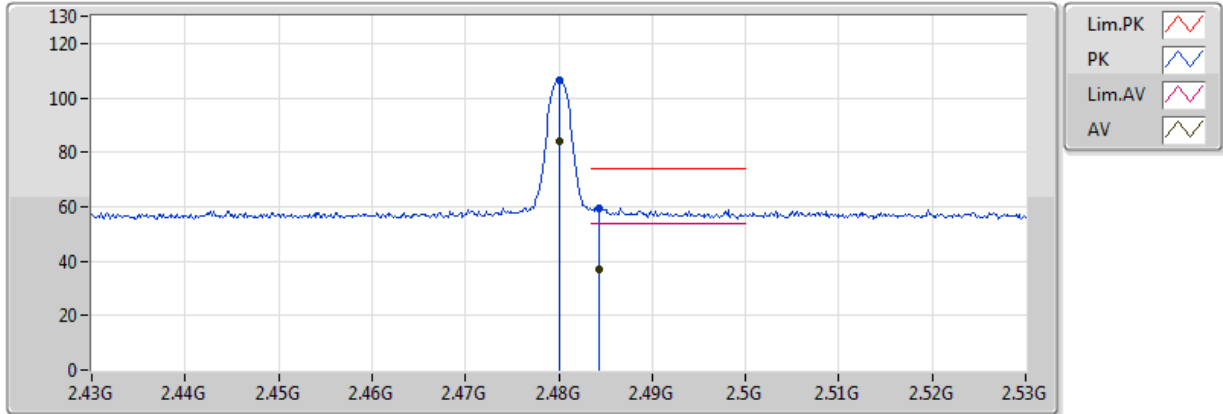

Type	Freq (Hz)	Level (dBuV/m)	Limit (dBuV/m)	Margin (dB)	Factor (dB)	Dist (m)	Condition	Azimuth (°)	Height (m)	Comments	Raw (dBuV)	AF (dB)	CL (dB)	PA (dB)
AV	2.48G	83.80	Inf	-Inf	30.78	3	Vertical	81	2.38	-	53.02	27.45	3.33	-
AV	2.484348G	37.04	54.00	-16.96	30.79	3	Vertical	81	2.38	-	6.25	27.46	3.33	-
PK	2.48G	106.30	Inf	-Inf	30.78	3	Vertical	81	2.38	-	75.52	27.45	3.33	-
PK	2.484348G	59.54	74.00	-14.46	30.79	3	Vertical	81	2.38	-	28.75	27.46	3.33	-

BT-EDR(3Mbps)

2480MHz_TX

11/03/2018

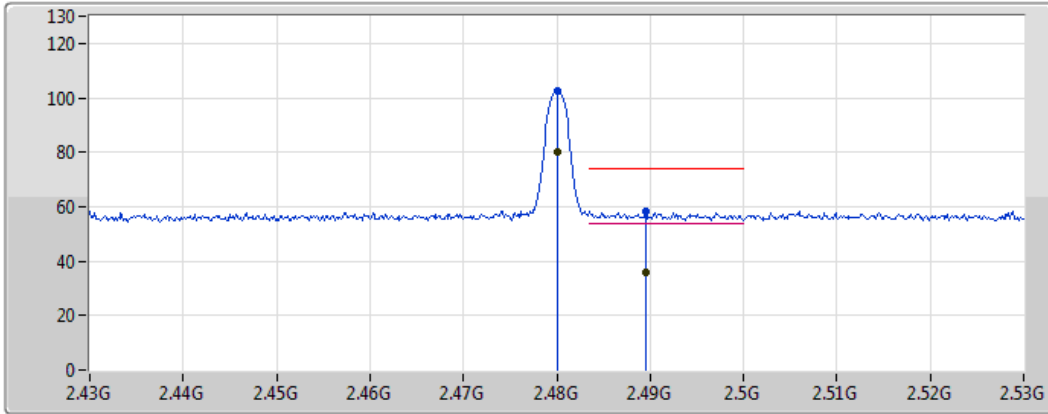

Legend for plot:

- Lim.PK (Red line)
- PK (Blue line)
- Lim.AV (Pink line)
- AV (Green line)

Type	Freq (Hz)	Level (dBuV/m)	Limit (dBuV/m)	Margin (dB)	Factor (dB)	Dist (m)	Condition	Azimuth (°)	Height (m)	Comments	Raw (dBuV)	AF (dB)	CL (dB)	PA (dB)
AV	2.48G	80.25	Inf	-Inf	30.78	3	Horizontal	97	1.08	-	49.47	27.45	3.33	-
AV	2.489565G	35.89	54.00	-18.11	30.81	3	Horizontal	97	1.08	-	5.08	27.47	3.34	-
PK	2.48G	102.76	Inf	-Inf	30.78	3	Horizontal	97	1.08	-	71.98	27.45	3.33	-
PK	2.489565G	58.39	74.00	-15.61	30.81	3	Horizontal	97	1.08	-	27.58	27.47	3.34	-