

FCC Test Report

FCC ID : YHICE-IMX6-01
Equipment : WLAN/BT Module
Brand Name : NEXCOM
Model No. : WG7833-B0
Applicant : NEXCOM International Co., LTD.
9F., No.920, Chung-Cheng Road, Zhonghe Dist.,
New Taipei City, Taiwan 235, R.O.C.
Manufacturer : NEXCOM International Co., LTD.
9F., No.920, Chung-Cheng Road, Zhonghe Dist.,
New Taipei City, Taiwan 235, R.O.C.
Standard : 47 CFR FCC Part 15.247

The product was received on Feb. 09, 2018, and testing was started from Mar. 08, 2018 and completed on Mar. 17, 2018. We, SPORTON INTERNATIONAL INC. EMC & Wireless Communications Laboratory, would like to declare that the tested sample has been evaluated in accordance with the procedures given in ANSI C63.10-2013 and shown compliance with the applicable technical standards.

The report must not be used by the client to claim product certification, approval, or endorsement by TAF or any agency of government.

The test results in this report apply exclusively to the tested model / sample. Without written approval of SPORTON INTERNATIONAL INC. EMC & Wireless Communications Laboratory, the test report shall not be reproduced except in full.

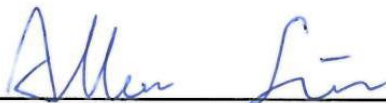

Approved by: Allen Lin

SPORTON INTERNATIONAL INC. EMC & Wireless Communications Laboratory

No. 52, Huaya 1st Rd., Guishan Dist., Taoyuan City, Taiwan (R.O.C.)



Table of Contents

HISTORY OF THIS TEST REPORT3

SUMMARY OF TEST RESULT4

1 GENERAL DESCRIPTION5

1.1 Information.....5

1.2 Testing Applied Standards7

1.3 Testing Location Information7

1.4 Measurement Uncertainty7

2 TEST CONFIGURATION OF EUT.....8

2.1 Test Condition8

2.2 Test Channel Mode8

2.3 The Worst Case Measurement Configuration.....9

2.4 Support Equipment.....10

2.5 Test Setup Diagram11

3 TRANSMITTER TEST RESULT13

3.1 AC Power-line Conducted Emissions13

3.2 DTS Bandwidth.....14

3.3 Maximum Conducted Output Power15

3.4 Power Spectral Density17

3.5 Emissions in Non-restricted Frequency Bands18

3.6 Emissions in Restricted Frequency Bands.....19

4 TEST EQUIPMENT AND CALIBRATION DATA.....23

APPENDIX A. TEST RESULTS OF AC POWER-LINE CONDUCTED EMISSIONS

APPENDIX B. TEST RESULTS OF DTS BANDWIDTH

APPENDIX C. TEST RESULTS OF MAXIMUM CONDUCTED OUTPUT POWER

APPENDIX D. TEST RESULTS OF POWER SPECTRAL DENSITY

APPENDIX E. TEST RESULTS OF EMISSIONS IN NON-RESTRICTED FREQUENCY BANDS

APPENDIX F. TEST RESULTS OF EMISSIONS IN RESTRICTED FREQUENCY BANDS

APPENDIX G. TEST PHOTOS

PHOTOGRAPHS OF EUT V01



Summary of Test Result

| Report Clause | Ref. Std. Clause | Test Items | Result (PASS/FAIL) | Remark |
|---------------|------------------|---|--------------------|----------------------------------|
| 1.1.2 | 15.203 | Antenna Requirement | PASS | FCC 15.203 |
| 3.1 | 15.207 | AC Power-line Conducted Emissions | PASS | FCC 15.207 |
| 3.2 | 15.247(a) | DTS Bandwidth | PASS | ≥500kHz |
| 3.3 | 15.247(b) | Maximum Conducted Output Power | PASS | Power [dBm]:30 |
| 3.4 | 15.247(e) | Power Spectral Density | PASS | PSD [dBm/3kHz]:8 |
| 3.5 | 15.247(d) | Emissions in Non-restricted Frequency Bands | PASS | Non-Restricted Bands: >30 dBc |
| 3.6 | 15.247(d) | Emissions in Restricted Frequency Bands | PASS | Restricted Bands: FCC 15.209 |

Reviewed by: Sam Tsai

Report Producer: Michelle Tsai

1 General Description

1.1 Information

1.1.1 RF General Information

| Frequency Range (MHz) | Bluetooth Mode | Ch. Frequency (MHz) | Channel Number |
|-----------------------|----------------|---------------------|----------------|
| 2400-2483.5 | LE | 2402-2480 | 0-39 [40] |

| Band | Mode | BWch (MHz) | Nant |
|---------------|--------------|------------|------|
| 2.4-2.4835GHz | BT-LE(1Mbps) | 1.0 | 1TX |

Note:

- ◆ Bluetooth LE uses a GFSK (1Mbps) modulation for DSSS.
- ◆ BWch is the nominal channel bandwidth.

1.1.2 Antenna Information

| Ant. | Port | Brand | Model Name | Antenna Type | Connector |
|------|------|------------------|------------|--------------|-----------|
| 1 | 1 | SMARTEQ WIRELESS | LPCA-MINO | OMNI Antenna | I-PEX |

| Ant. | Gain (dBi) | |
|------|------------|------|
| | 2.4G | BT |
| 1 | 2.15 | 2.15 |

Note: The antenna mentioned above will not be sold with the EUT in the market.



1.1.3 EUT Information

| Operational Condition | |
|-------------------------------------|---|
| EUT Power Type | From Host system |
| RF Chip | WG7833-B0 |
| Type of EUT | |
| <input checked="" type="checkbox"/> | Stand-alone |
| <input type="checkbox"/> | Combined (EUT where the radio part is fully integrated within another device) |
| | Combined Equipment - Brand Name / Model No.: ... |
| <input type="checkbox"/> | Plug-in radio (EUT intended for a variety of host systems) |
| | Host System - Brand Name / Model No.: ... |
| <input type="checkbox"/> | Other: |

1.1.4 Mode Test Duty Cycle

| Mode | DC | DCF(dB) | T(s) | VBW(Hz) $\geq 1/T$ |
|--------------|------|---------|---------|--------------------|
| BT-LE(1Mbps) | 0.65 | 1.871 | 406.25u | 3k |

1.2 Testing Applied Standards

According to the specifications of the manufacturer, the EUT must comply with the requirements of the following standards:

- ◆ 47 CFR FCC Part 15
- ◆ ANSI C63.10-2013
- ◆ KDB 558074 D01 v04

1.3 Testing Location Information

| Testing Location | | | | |
|--|--------|--|----------------------|--|
| <input checked="" type="checkbox"/> | HWA YA | ADD : No. 52, Huaya 1st Rd., Guishan Dist., Taoyuan City, Taiwan (R.O.C.) | | |
| | | TEL : 886-3-327-3456 | FAX : 886-3-327-0973 | |
| Test site Designation No. TW1190 with FCC. | | | | |
| <input type="checkbox"/> | JHUBEI | ADD : No.8, Ln. 724, Bo'ai St., Zhubei City, Hsinchu County, Taiwan (R.O.C.) | | |
| | | TEL : 886-3-656-9065 | FAX : 886-3-656-9085 | |
| Test site Designation No. TW0006 with FCC. | | | | |

| Test Condition | Test Site No. | Test Engineer | Test Environment | Test Date |
|----------------|---------------|---------------|------------------|-------------|
| RF Conducted | TH01-HY | Randy | 22.5°C / 62% | 08/Mar/2018 |
| Radiated | 03CH03-HY | Jerry | 22.2°C / 51.8% | 11/Mar/2018 |
| AC Conduction | CO04-HY | Daniel | 21.6°C / 52.8% | 17/Mar/2018 |

1.4 Measurement Uncertainty

ISO/IEC 17025 requires that an estimate of the measurement uncertainties associated with the emissions test results be included in the report. The measurement uncertainties given below are based on a 95% confidence level (based on a coverage factor (k=2))

| Test Items | Uncertainty | Remark |
|--------------------------------------|-------------|--------------------------|
| Conducted Emission (150kHz ~ 30MHz) | 3.6 dB | Confidence levels of 95% |
| Radiated Emission (9kHz ~ 30MHz) | 3.0 dB | Confidence levels of 95% |
| Radiated Emission (30MHz ~ 1,000MHz) | 4.3 dB | Confidence levels of 95% |
| Radiated Emission (1GHz ~ 18GHz) | 3.9 dB | Confidence levels of 95% |
| Radiated Emission (18GHz ~ 40GHz) | 3.5 dB | Confidence levels of 95% |
| Conducted Emission | 1.3 dB | Confidence levels of 95% |
| Temperature | 0.7 °C | Confidence levels of 95% |
| Humidity | 4 % | Confidence levels of 95% |

2 Test Configuration of EUT

2.1 Test Condition

| Condition Item | Abbreviation/Remark | Remark |
|------------------|---------------------|--------|
| RF Conducted-DTS | Abbreviation | Remark |
| TnomVnom | Tnom | 20°C |
| - | Vnom | 120V |

2.2 Test Channel Mode

| Mode | Power Setting |
|--------------|---------------|
| BT-LE(1Mbps) | - |
| 2402MHz | Default |
| 2440MHz | Default |
| 2480MHz | Default |

2.3 The Worst Case Measurement Configuration

| The Worst Case Mode for Following Conformance Tests | |
|---|--|
| Tests Item | AC power-line conducted emissions |
| Condition | AC power-line conducted measurement for line and neutral |
| Operating Mode | CTX |
| 1 | USB Mode ; 2.4G TX |

| The Worst Case Mode for Following Conformance Tests | |
|---|--|
| Tests Item | DTS Bandwidth Maximum Conducted Output Power Power Spectral Density Emissions in Non-restricted Frequency Bands |
| Test Condition | Conducted measurement at transmit chains |

| The Worst Case Mode for Following Conformance Tests | |
|---|---|
| Tests Item | Emissions in Restricted Frequency Bands |
| Test Condition | Radiated measurement If EUT consist of multiple antenna assembly (multiple antenna are used in EUT regardless of spatial multiplexing MIMO configuration), the radiated test should be performed with highest antenna gain of each antenna type. |
| Operating Mode < 1GHz | CTX |
| 1 | USB Mode |
| Operating Mode > 1GHz | CTX |
| Orthogonal Planes of EUT | Z Plane |
| |  |

2.4 Support Equipment

| Support Equipment – RF Conducted | | | | |
|---|-------------------------|-------------------|-------------------|---------------|
| No. | Equipment | Brand Name | Model Name | FCC ID |
| 1 | Notebook | DELL | E5410 | R33002 / DoC |
| 2 | AC Adapter for Notebook | DELL | HA65NM130 | R35737 / DoC |
| 3 | Fixture | - | - | - |

Note: Support equipment No.3 was provided by customer.

| Support Equipment – Radiated Emission | | | | |
|--|-------------------------|---------------------|-------------------|---------------|
| No. | Equipment | Brand Name | Model Name | FCC ID |
| 1 | Notebook | DELL | E5530 | R33002 |
| 2 | AC Adapter for Notebook | DELL | LA65NS2-01 | DoC |
| 3 | Fixture | - | - | - |
| 4 | Antenna | SMARTEQ WIRELESS | LPCA-MINO | - |

Note: Support equipment No.3 was provided by customer.

| Support Equipment – AC Conduction | | | | |
|--|-------------------------|---------------------|-------------------|---------------|
| No. | Equipment | Brand Name | Model Name | FCC ID |
| 1 | Notebook | DELL | E5530 | R33002 |
| 2 | AC Adapter for Notebook | DELL | LA65NS2-01 | DoC |
| 3 | Fixture | - | - | - |
| 4 | Antenna | SMARTEQ WIRELESS | LPCA-MINO | - |

Note: Support equipment No.3 was provided by customer.

2.5 Test Setup Diagram

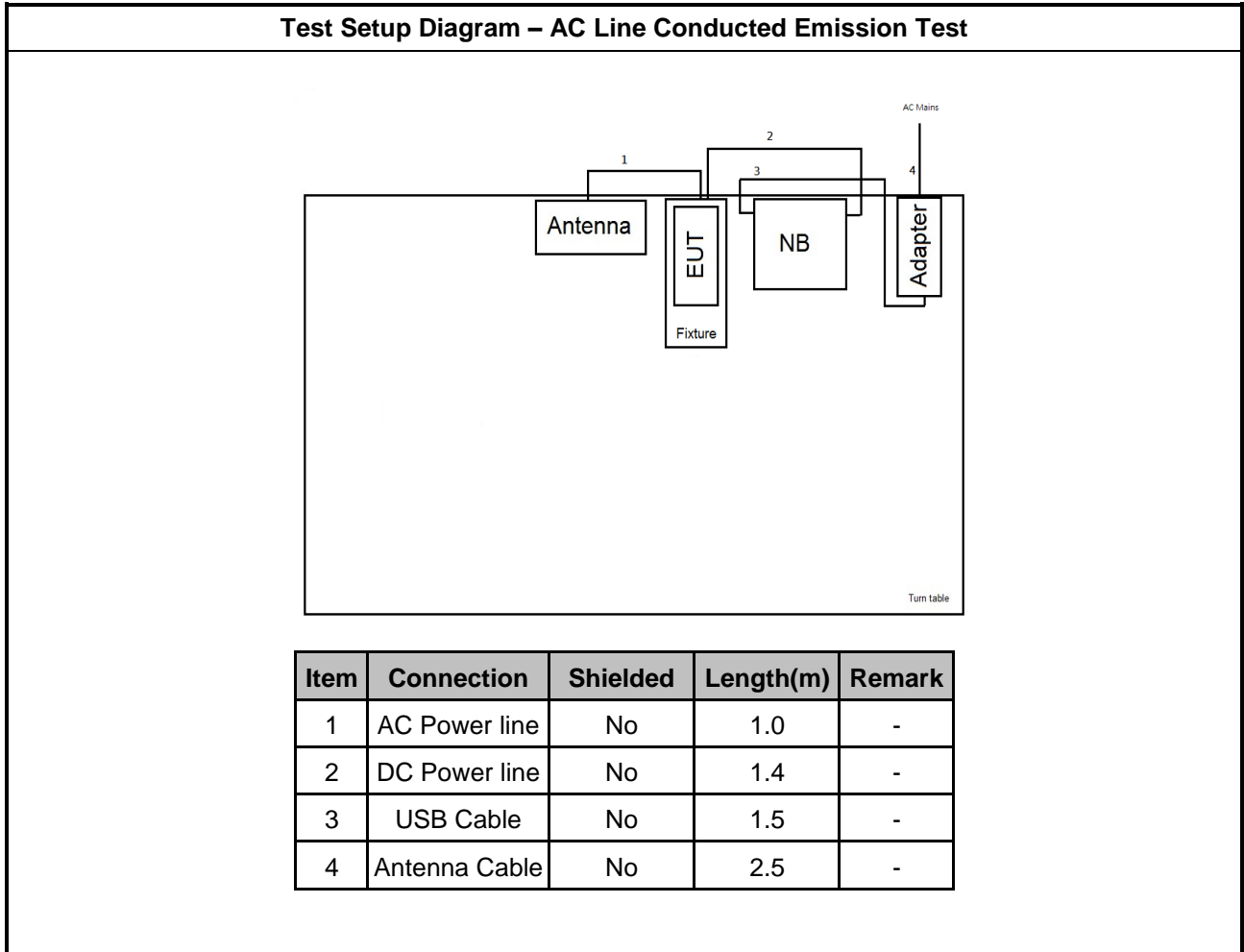

Test Setup Diagram - Radiated Test

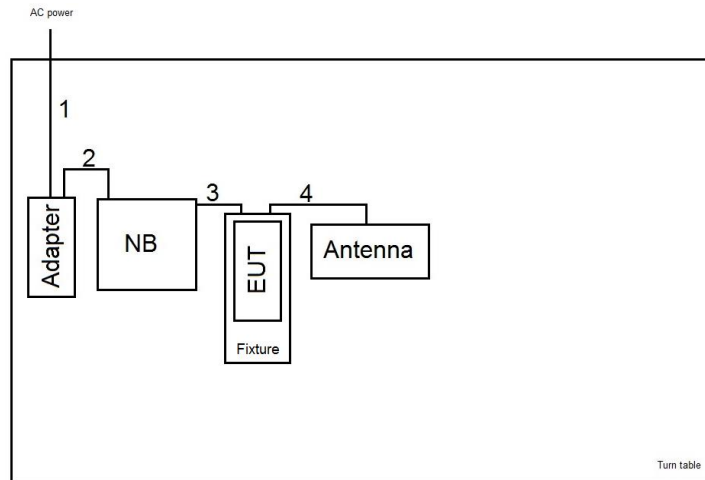

| Item | Connection | Shielded | Length(m) | Remark |
|------|---------------|----------|-----------|--------|
| 1 | AC Power line | No | 1.0 | - |
| 2 | DC Power line | No | 1.4 | - |
| 3 | USB Cable | No | 1.5 | - |
| 4 | Antenna Cable | No | 2.5 | - |

3 Transmitter Test Result

3.1 AC Power-line Conducted Emissions

3.1.1 AC Power-line Conducted Emissions Limit

| AC Power-line Conducted Emissions Limit | | |
|---|------------|-----------|
| Frequency Emission (MHz) | Quasi-Peak | Average |
| 0.15-0.5 | 66 - 56 * | 56 - 46 * |
| 0.5-5 | 56 | 46 |
| 5-30 | 60 | 50 |

Note 1: * Decreases with the logarithm of the frequency.

3.1.2 Measuring Instruments

Refer a test equipment and calibration data table in this test report.

3.1.3 Test Procedures

| Test Method |
|---|
| <ul style="list-style-type: none"> Refer as ANSI C63.10-2013, clause 6.2 foray power-line conducted emissions. |

3.1.4 Test Setup

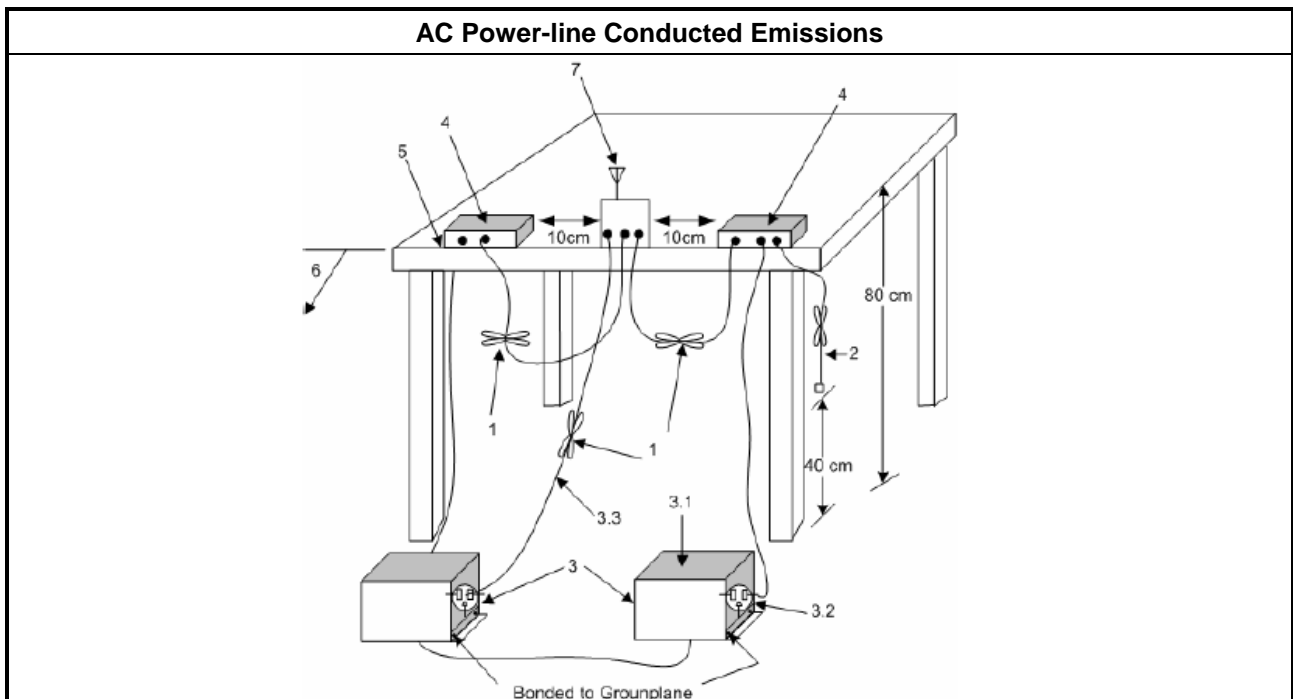

3.1.5 Test Result of AC Power-line Conducted Emissions

Refer as Appendix A

3.2 DTS Bandwidth

3.2.1 6dB Bandwidth Limit

| 6dB Bandwidth Limit |
|---|
| Systems using digital modulation techniques: |
| <ul style="list-style-type: none"> ▪ 6 dB bandwidth \geq 500 kHz. |

3.2.2 Measuring Instruments

Refer a test equipment and calibration data table in this test report.

3.2.3 Test Procedures

| Test Method |
|--|
| <ul style="list-style-type: none"> ▪ For the emission bandwidth shall be measured using one of the options below: |
| <input checked="" type="checkbox"/> Refer as KDB 558074, clause 8.1 Option 1 for 6 dB bandwidth measurement. |
| <input type="checkbox"/> Refer as KDB 558074, clause 8.2 Option 2 for 6 dB bandwidth measurement. |
| <input type="checkbox"/> Refer as ANSI C63.10, clause 6.9.3 for occupied bandwidth testing. |
| <input type="checkbox"/> Refer as RSS-Gen, clause 6.6 for occupied bandwidth testing. |

3.2.4 Test Setup

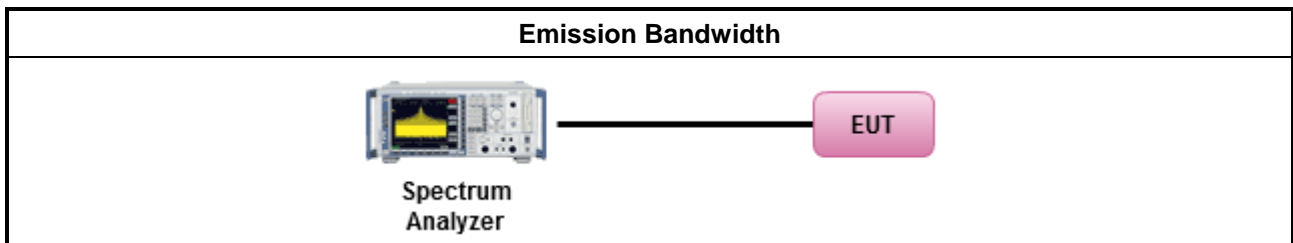

3.2.5 Test Result of Emission Bandwidth

Refer as Appendix B

3.3 Maximum Conducted Output Power

3.3.1 Maximum Conducted Output Power Limit

| Maximum Conducted Output Power Limit | |
|---|---|
| | <ul style="list-style-type: none"> ▪ If $G_{TX} \leq 6$ dBi, then $P_{Out} \leq 30$ dBm (1 W) |
| | <ul style="list-style-type: none"> ▪ Point-to-multipoint systems (P2M): If $G_{TX} > 6$ dBi, then $P_{Out} = 30 - (G_{TX} - 6)$ dBm |
| | <ul style="list-style-type: none"> ▪ Point-to-point systems (P2P): If $G_{TX} > 6$ dBi, then $P_{Out} = 30 - (G_{TX} - 6)/3$ dBm |
| | <ul style="list-style-type: none"> ▪ Smart antenna system (SAS): |
| | <ul style="list-style-type: none"> - Single beam: If $G_{TX} > 6$ dBi, then $P_{Out} = 30 - (G_{TX} - 6)/3$ dBm |
| | <ul style="list-style-type: none"> - Overlap beam: If $G_{TX} > 6$ dBi, then $P_{Out} = 30 - (G_{TX} - 6)/3$ dBm |
| | <ul style="list-style-type: none"> - Aggregate power on all beams: If $G_{TX} > 6$ dBi, then $P_{Out} = 30 - (G_{TX} - 6)/3 + 8$ dB dBm |
| e.i.r.p. Power Limit: | |
| | <ul style="list-style-type: none"> ▪ 2400-2483.5 MHz Band |
| | <ul style="list-style-type: none"> ▪ Point-to-multipoint systems (P2M): $P_{eirp} \leq 36$ dBm (4 W) |
| | <ul style="list-style-type: none"> ▪ Point-to-point systems (P2P): $P_{eirp} \leq \text{MAX}(36, [P_{Out} + G_{TX}])$ dBm |
| | <ul style="list-style-type: none"> ▪ Smart antenna system (SAS) |
| | <ul style="list-style-type: none"> - Single beam: $P_{eirp} \leq \text{MAX}(36, P_{Out} + G_{TX})$ dBm |
| | <ul style="list-style-type: none"> - Overlap beam: $P_{eirp} \leq \text{MAX}(36, P_{Out} + G_{TX})$ dBm |
| | <ul style="list-style-type: none"> - Aggregate power on all beams: $P_{eirp} \leq \text{MAX}(36, [P_{Out} + G_{TX} + 8])$ dBm |
| P_{Out} = maximum peak conducted output power or maximum conducted output power in dBm, G_{TX} = the maximum transmitting antenna directional gain in dBi. | |

3.3.2 Measuring Instruments

Refer a test equipment and calibration data table in this test report.

3.3.3 Test Procedures

| Test Method | |
|--|---|
| <ul style="list-style-type: none"> ▪ Maximum Peak Conducted Output Power | |
| <input type="checkbox"/> | Refer as KDB 558074, clause 9.1.1 Option 1 (RBW ≥ EBW method). |
| <input type="checkbox"/> | Refer as KDB 558074, clause 9.1.2 Option 2 (integrated band power method) |
| <input type="checkbox"/> | Refer as KDB 558074, clause 9.1.3 Option 3 (peak power meter for VBW ≥ DTS BW) |
| <ul style="list-style-type: none"> ▪ Maximum Average Conducted Output Power | |
| Duty cycle ≥ 98% | |
| <input type="checkbox"/> | Refer as KDB 558074, clause 9.2.2.4 Method AVGSA-2 (spectral trace averaging). |
| Duty cycle < 98% | |
| <input type="checkbox"/> | Refer as KDB 558074, clause 9.2.2.5 Method AVGSA-2 Alt. (slow sweep speed) |
| RF power meter and average over on/off periods with duty factor or gated trigger | |
| <input checked="" type="checkbox"/> | Refer as KDB 558074, clause 9.2.3.1 Method AVGPM (using an RF average power meter). |
| <ul style="list-style-type: none"> ▪ For conducted measurement. | |
| <ul style="list-style-type: none"> ▪ If the EUT supports multiple transmit chains using options given below: Refer as KDB 662911, In-band power measurements. Using the measure-and-sum approach, measured all transmit ports individually. Sum the power (in linear power units e.g., mW) of all ports for each individual sample and save them. | |
| <ul style="list-style-type: none"> ▪ If multiple transmit chains, EIRP calculation could be following as methods: $P_{total} = P_1 + P_2 + \dots + P_n$ (calculated in linear unit [mW] and transfer to log unit [dBm]) $EIRP_{total} = P_{total} + DG$ | |

3.3.4 Test Setup

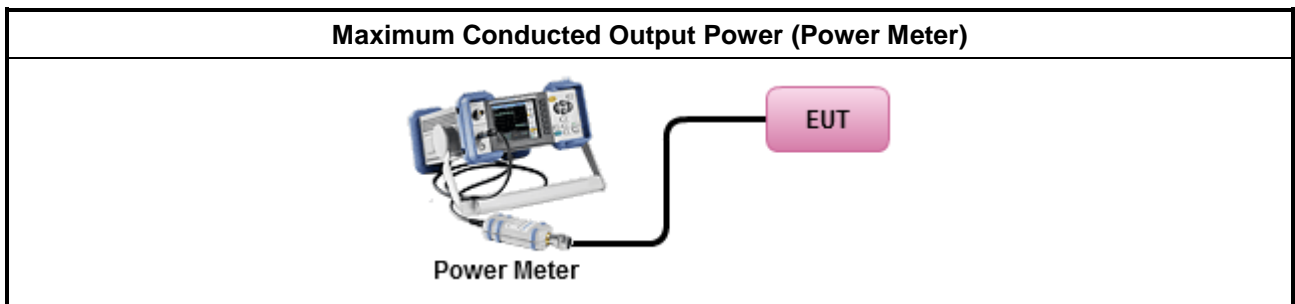

3.3.5 Test Result of Maximum Conducted Output Power

Refer as Appendix C

3.4 Power Spectral Density

3.4.1 Power Spectral Density Limit

| Power Spectral Density Limit |
|---|
| <ul style="list-style-type: none"> Power Spectral Density (PSD) ≤ 8 dBm/3kHz |

3.4.2 Measuring Instruments

Refer a test equipment and calibration data table in this test report.

3.4.3 Test Procedures

| Test Method |
|---|
| <ul style="list-style-type: none"> Peak power spectral density procedures that the same method as used to determine the conducted output power. If maximum peak conducted output power was measured to demonstrate compliance to the output power limit, then the peak PSD procedure below (Method PKPSD) shall be used. If maximum conducted output power was measured to demonstrate compliance to the output power limit, then one of the average PSD procedures shall be used, as applicable based on the following criteria (the peak PSD procedure is also an acceptable option). |
| <input checked="" type="checkbox"/> Refer as KDB 558074, clause 10.2 Method PKPSD (RBW=3-100kHz; Detector=peak). |
| <ul style="list-style-type: none"> For conducted measurement. <ul style="list-style-type: none"> If The EUT supports multiple transmit chains using options given below: <ul style="list-style-type: none"> Measure and sum the spectra across the outputs. Refer as KDB 662911, In-band power spectral density (PSD). Sample all transmit ports simultaneously using a spectrum analyzer for each transmit port. Where the trace bin-by-bin of each transmit port summing can be performed. (i.e., in the first spectral bin of output 1 is summed with that in the first spectral bin of output 2 and that from the first spectral bin of output 3, and so on up to the NTX output to obtain the value for the first frequency bin of the summed spectrum.). Add up the amplitude (power) values for the different transmit chains and use this as the new data trace. |

3.4.4 Test Setup

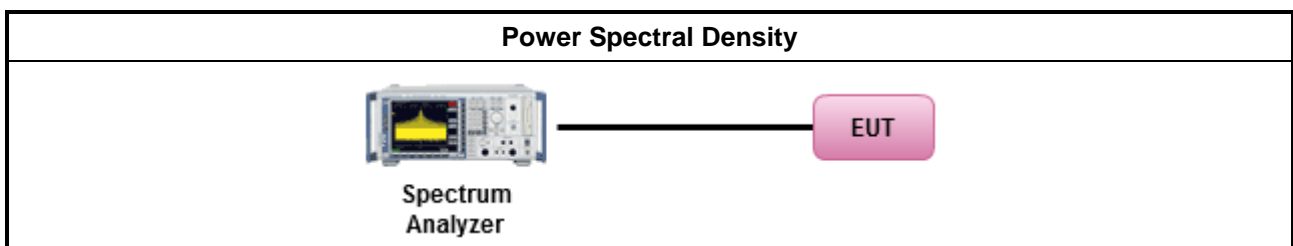

3.4.5 Test Result of Power Spectral Density

Refer as Appendix D

3.5 Emissions in Non-restricted Frequency Bands

3.5.1 Emissions in Non-restricted Frequency Bands Limit

| Un-restricted Band Emissions Limit | |
|------------------------------------|------------|
| RF output power procedure | Limit (dB) |
| Peak output power procedure | 20 |
| Average output power procedure | 30 |

Note 1: If the peak output power procedure is used to measure the fundamental emission power to demonstrate compliance to requirements, then the peak conducted output power measured within any 100 kHz outside the authorized frequency band shall be attenuated by at least 20 dB relative to the maximum measured in-band peak PSD level.

Note 2: If the average output power procedure is used to measure the fundamental emission power to demonstrate compliance to requirements, then the power in any 100 kHz outside of the authorized frequency band shall be attenuated by at least 30 dB relative to the maximum measured in-band average PSD level.

3.5.2 Measuring Instruments

Refer a test equipment and calibration data table in this test report.

3.5.3 Test Procedures

| Test Method |
|--|
| <ul style="list-style-type: none"> Refer as KDB 558074, clause 11 for unwanted emissions into non-restricted bands. |

3.5.4 Test Setup

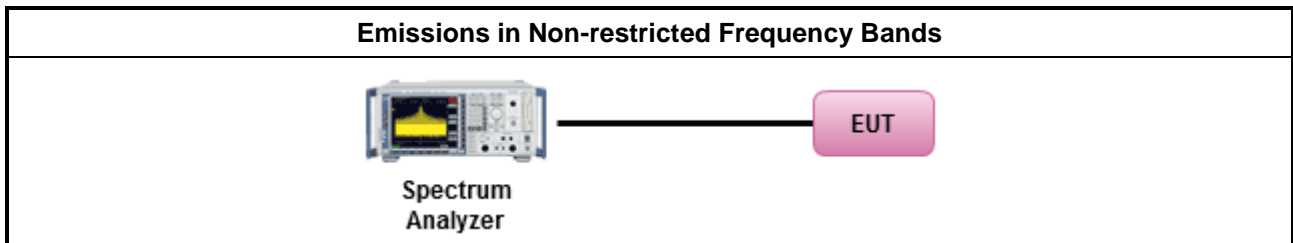

3.5.5 Test Result of Emissions in Non-restricted Frequency Bands

Refer as Appendix E

3.6 Emissions in Restricted Frequency Bands

3.6.1 Emissions in Restricted Frequency Bands Limit

| Restricted Band Emissions Limit | | | |
|---------------------------------|-----------------------|-------------------------|----------------------|
| Frequency Range (MHz) | Field Strength (uV/m) | Field Strength (dBuV/m) | Measure Distance (m) |
| 0.009~0.490 | 2400/F(kHz) | 48.5 - 13.8 | 300 |
| 0.490~1.705 | 24000/F(kHz) | 33.8 - 23 | 30 |
| 1.705~30.0 | 30 | 29 | 30 |
| 30~88 | 100 | 40 | 3 |
| 88~216 | 150 | 43.5 | 3 |
| 216~960 | 200 | 46 | 3 |
| Above 960 | 500 | 54 | 3 |

Note 1: Test distance for frequencies at or above 30 MHz, measurements may be performed at a distance other than the limit distance provided they are not performed in the near field and the emissions to be measured can be detected by the measurement equipment. When performing measurements at a distance other than that specified, the results shall be extrapolated to the specified distance using an extrapolation factor of 20 dB/decade (inverse of linear distance for field-strength measurements, inverse of linear distance-squared for power-density measurements).

Note 2: Test distance for frequencies at below 30 MHz, measurements may be performed at a distance closer than the EUT limit distance; however, an attempt should be made to avoid making measurements in the near field. When performing measurements below 30 MHz at a closer distance than the limit distance, the results shall be extrapolated to the specified distance by either making measurements at a minimum of two or more distances on at least one radial to determine the proper extrapolation factor or by using the square of an inverse linear distance extrapolation factor (40 dB / decade). The test report shall specify the extrapolation method used to determine compliance of the EUT.

Note 3: Using the distance of 1m during the test for above 18 GHz, and the test value to correct for the distance factor at 3m.

3.6.2 Measuring Instruments

Refer a test equipment and calibration data table in this test report.

3.6.3 Test Procedures

| Test Method | |
|--|---|
| <ul style="list-style-type: none"> ▪ The average emission levels shall be measured in [duty cycle \geq 98 or duty factor]. | |
| <ul style="list-style-type: none"> ▪ Refer as ANSI C63.10, clause 6.10.3 band-edge testing shall be performed at the lowest frequency channel and highest frequency channel within the allowed operating band. | |
| <ul style="list-style-type: none"> ▪ For the transmitter unwanted emissions shall be measured using following options below: | |
| <ul style="list-style-type: none"> ▪ Refer as KDB 558074, clause 12 for unwanted emissions into restricted bands. | |
| | <input checked="" type="checkbox"/> Refer as KDB 558074, clause 12.2.5.3 (ANSI C63.10, clause 4.1.4.2.3), Reduced VBW \geq 1/T. |
| | <input checked="" type="checkbox"/> Refer as KDB 558074, clause 12.2.4 measurement procedure peak limit. |
| <ul style="list-style-type: none"> ▪ For the transmitter band-edge emissions shall be measured using following options below: | |
| <ul style="list-style-type: none"> ▪ Refer as KDB 558074 clause 13.1, When the performing peak or average radiated measurements, emissions within 2 MHz of the authorized band edge may be measured using the marker-delta method described below. | |
| <ul style="list-style-type: none"> ▪ Refer as KDB 558074, clause 13.2 (ANSI C63.10, clause 6.10.6) for marker-delta method for band-edge measurements. | |
| <ul style="list-style-type: none"> ▪ Refer as KDB 558074, clause 13.3 for narrower resolution bandwidth (100kHz) using the band power and summing the spectral levels (i.e., 1 MHz). | |
| <ul style="list-style-type: none"> ▪ For conducted and cabinet radiation measurement, refer as KDB 558074, clause 12.2.2. | |
| <ul style="list-style-type: none"> ▪ For conducted unwanted emissions into restricted bands (absolute emission limits). Devices with multiple transmit chains using options given below: (1) Measure and sum the spectra across the outputs or (2) Measure and add 10 log(N) dB | |
| <ul style="list-style-type: none"> ▪ For KDB 662911 The methodology described here may overestimate array gain, thereby resulting in apparent failures to satisfy the out-of-band limits even if the device is actually compliant. In such cases, compliance may be demonstrated by performing radiated tests around the frequencies at which the apparent failures occurred. | |

3.6.4 Test Setup

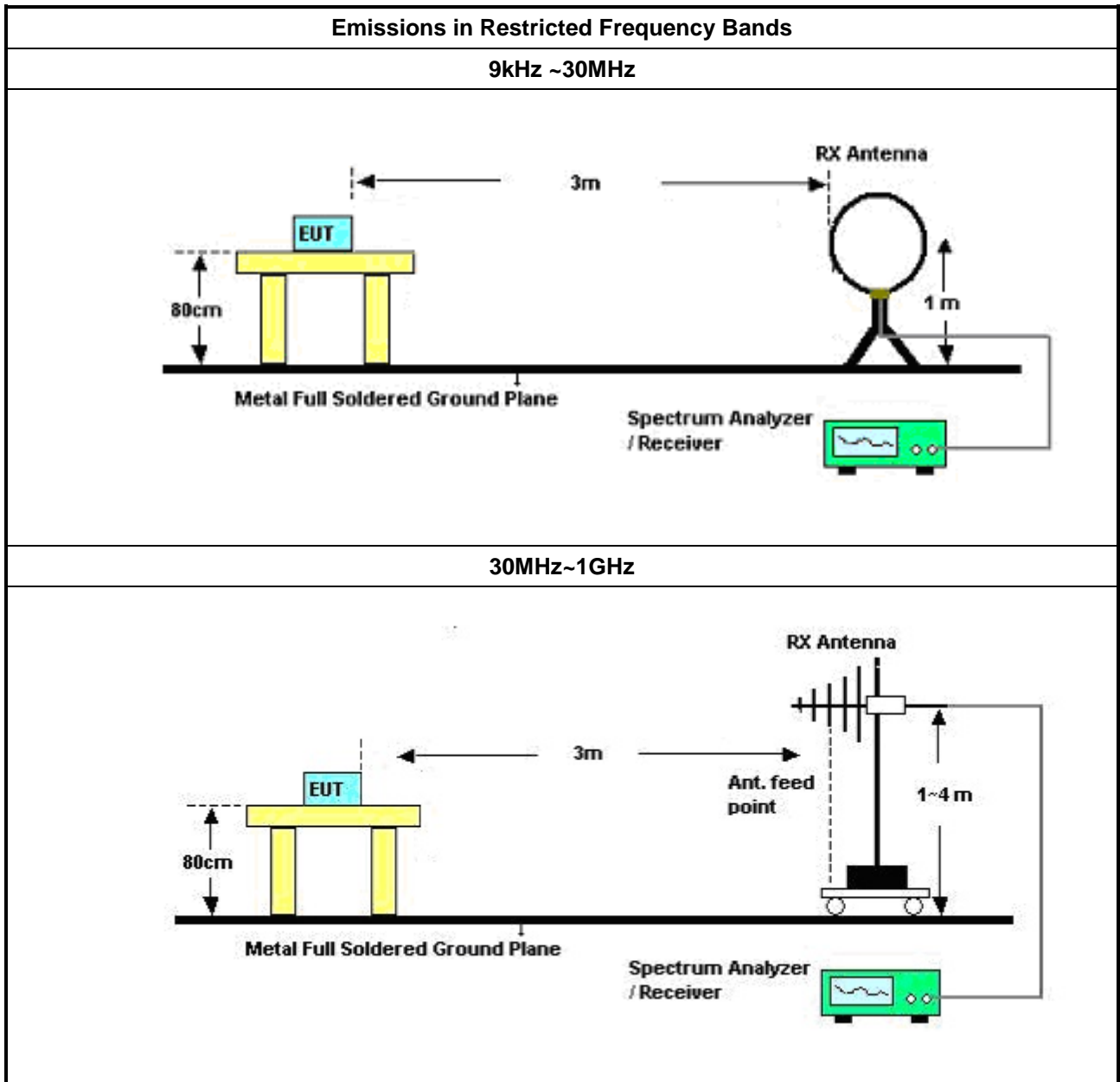

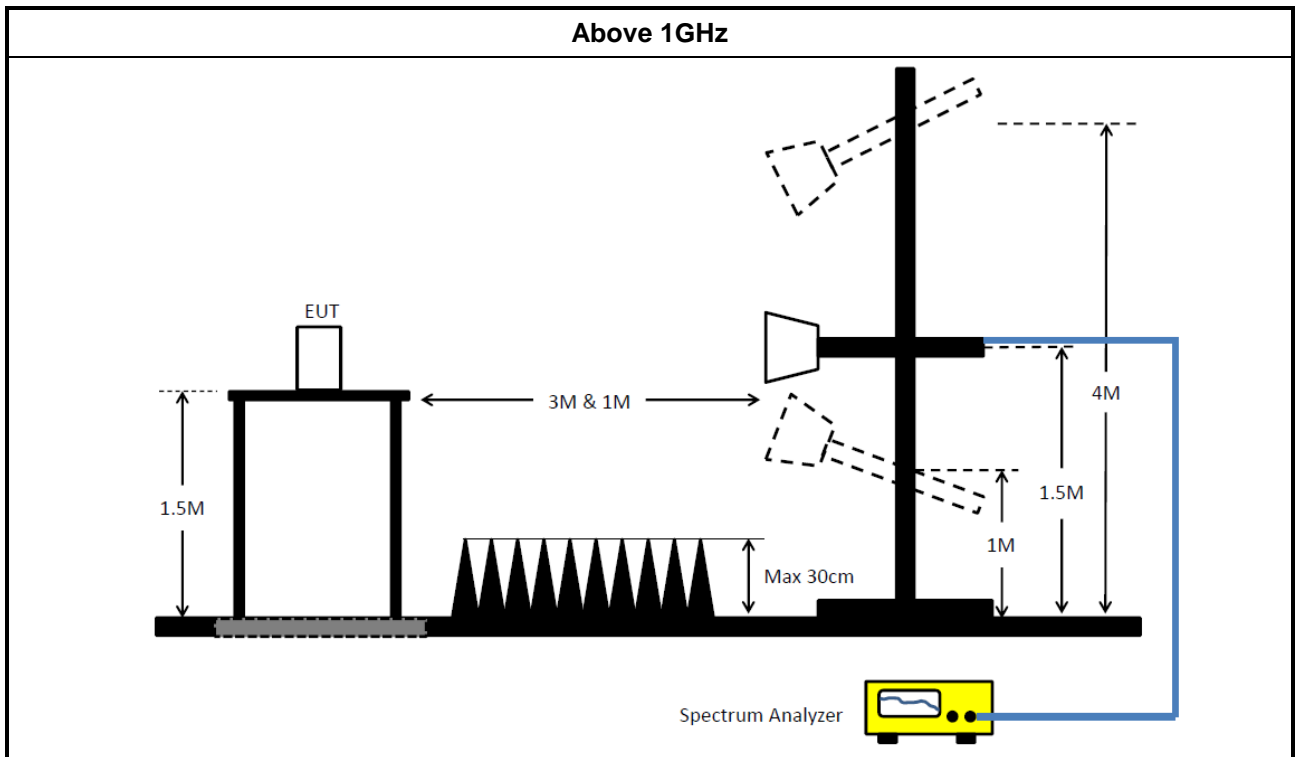

3.6.5 Test Result of Emissions in Restricted Frequency Bands (Below 30MHz)

The amplitude of spurious emissions which are attenuated by more than 20dB below the permissible value has no need to be reported.

3.6.6 Test Result of Emissions in Restricted Frequency Bands

Refer as Appendix F

4 Test Equipment and Calibration Data

Instrument for AC Conduction

| Instrument | Manufacturer | Model No. | Serial No. | Spec. | Calibration Date | Calibration Due Date |
|--------------------------------------|--------------|-------------|----------------|---------------------|------------------|----------------------|
| EMC Receiver | R&S | ESR3 | 102052 | 9KHz ~ 3.6GHz | 29/Apr/2017 | 28/Apr/2018 |
| LISN | R&S | ENV216 | 101295 | 9kHz ~ 30MHz | 17/Nov/2017 | 16/Nov/2018 |
| RF Cable-CON | HUBER+SUHNER | RG213/U | 07611832020001 | 9kHz ~ 30MHz | 06/Oct/2017 | 05/Oct/2018 |
| AC POWER | APC | AFC-11005G | F310050055 | 47Hz~63Hz 5~300V | NCR | NCR |
| Impuls Begrenzer Pulse Limiter | SCHWARZBECK | VTSD 9561-F | 9561-F041 | 9 kHz ~ 30 MHz | 12/Oct/2017 | 11/Oct/2018 |

NCR : Non-Calibration Require

Instrument for Radiated Test

| Instrument | Manufacturer | Model No. | Serial No. | Spec. | Calibration Date | Calibration Due Date |
|--------------------------------|----------------|-------------|-------------|--------------------|------------------|----------------------|
| 3m Semi Anechoic Chamber | SIDT FRANKONIA | SAC-3M | 03CH03-HY | 30MHz ~ 1GHz 3m | 31/Oct/2017 | 30/Oct/2018 |
| 3m Semi Anechoic Chamber | SIDT FRANKONIA | SAC-3M | 03CH03-HY | 1GHz ~ 18GHz 3m | 01/Nov/2017 | 31/Oct/2018 |
| Amplifier | HP | 8447D | 2944A08033 | 10kHz ~ 1.3GHz | 19/Apr/2017 | 18/Apr/2018 |
| Amplifier | Keysight | 83017A | MY53270196 | 1GHz ~ 26.5GHz | 31/Aug/2017 | 30/Aug/2018 |
| Spectrum | R&S | FSV40 | 101500 | 9kHz ~ 40GHz | 28/Jun/2017 | 27/Jun/2018 |
| Receiver | R&S | ESR3 | 102052 | 9KHz ~ 3.6GHz | 29/Apr/2017 | 28/Apr/2018 |
| RF Cable-R03m | Jye Bao | RG142 | CB021 | 9kHz ~ 1GHz | 26/Jan/2018 | 25/Jan/2019 |
| RF Cable-high | SUHNER | SUCOFLEX106 | CB222 | 1GHz ~ 40GHz | 26/Jan/2018 | 25/Jan/2019 |
| Bilog Antenna | SCHAFFNER | CBL 6112B | 22237 | 30MHz ~ 1GHz | 08/Jul/2017 | 07/Jul/2018 |
| Horn Antenna | SCHWARZBECK | BBHA9170 | BBHA9170154 | 18GHz ~ 40GHz | 06/Feb/ 2018 | 05/Feb/2019 |
| Horn Antenna | SCHWARZBECK | BBHA9120D | 1531 | 1GHz ~ 18GHz | 25/Apr/ 2017 | 24/Apr/2018 |

Instrument for Conducted Test

| Instrument | Manufacturer | Model No. | Serial No. | Spec. | Calibration Date | Calibration Due Date |
|----------------------|--------------|--------------|------------|-----------------|------------------|----------------------|
| Spectrum Analyzer | R&S | FSV 40 | 101515 | 9kHz~40GHz | 08/Dec/2017 | 07/Dec/2018 |
| Power Sensor | Anritsu | MA2411B | 1339407 | 300MHz ~ 40GHz | 10/May/2017 | 09/May/2018 |
| Power Meter | Anritsu | ML2495A | 1517010 | 300MHz ~ 40GHz | 06/Nov/2017 | 05/Nov/2018 |
| Signal Generator | R&S | SMR40 | 100116 | 10MHz ~ 40GHz | 27/Jul/2017 | 26/Jul/2018 |
| RF Cable-0.2m | HUBER+SUHNER | SUCOFLEX_104 | MY677/3 | 30MHz ~ 26.5GHz | 25/Aug/2017 | 24/Aug/2018 |
| RF Cable-0.2m | HUBER+SUHNER | SUCOFLEX_104 | MY678/3 | 30MHz ~ 26.5GHz | 25/Aug/2017 | 24/Aug/2018 |
| RF Cable-0.5m | HUBER+SUHNER | SUCOFLEX_104 | MY10717/4 | 30MHz ~ 26.5GHz | 25/Aug/2017 | 24/Aug/2018 |



| AC Power-line Conducted Emissions Result | | | | | | | | | | | | | | | | | | | | | | | | | | | | | | | | | | | | | | | | | | | | | | | | | | | | | | | | | | | | | | | | | | | | | | | | | | | | | | | | | | | | | | | | | | | | | | | | | | | | | | | | | | | | | | | | | | | | | | | | | | | | | | | | | |
|---|----------------------|--------------|---------------|--------------|--------------|-------------|-------------|----------------|------------|-------------|------------|--------|--|-----|------|----|------|------|----|----|--|---|--------|-------|--------|-------|-------|------|------|---------|---|--------|-------|--------|-------|-------|------|------|----|---|--------|-------|--------|-------|-------|------|------|---------|---|--------|-------|--------|-------|-------|------|------|----|---|--------|-------|--------|-------|-------|------|------|---------|---|--------|-------|--------|-------|-------|------|------|----|--------------|---------------|--------------|---------------|--------------|--------------|-------------|-------------|----------------|---|--------|-------|--------|-------|-------|------|------|----|---|--------|-------|--------|-------|-------|------|------|---------|----|--------|-------|--------|-------|-------|------|------|----|----|---------|-------|--------|-------|-------|------|------|---------|----|---------|-------|--------|-------|-------|------|------|----|
| Operating Mode | 1 | Power Phase | Neutral | | | | | | | | | | | | | | | | | | | | | | | | | | | | | | | | | | | | | | | | | | | | | | | | | | | | | | | | | | | | | | | | | | | | | | | | | | | | | | | | | | | | | | | | | | | | | | | | | | | | | | | | | | | | | | | | | | | | | | | | | | | | | | |
| Operating Function | USB Mode ; BT 4.0 TX | | | | | | | | | | | | | | | | | | | | | | | | | | | | | | | | | | | | | | | | | | | | | | | | | | | | | | | | | | | | | | | | | | | | | | | | | | | | | | | | | | | | | | | | | | | | | | | | | | | | | | | | | | | | | | | | | | | | | | | | | | | | | | | | |
| | | | | | | | | | | | | | | | | | | | | | | | | | | | | | | | | | | | | | | | | | | | | | | | | | | | | | | | | | | | | | | | | | | | | | | | | | | | | | | | | | | | | | | | | | | | | | | | | | | | | | | | | | | | | | | | | | | | | | | | | | | | | | | | | | |
| Date: 2018-03-17 | | | | | | | | | | | | | | | | | | | | | | | | | | | | | | | | | | | | | | | | | | | | | | | | | | | | | | | | | | | | | | | | | | | | | | | | | | | | | | | | | | | | | | | | | | | | | | | | | | | | | | | | | | | | | | | | | | | | | | | | | | | | | | | | | |
| <table border="1" style="width:100%; border-collapse: collapse;"> <thead> <tr> <th></th> <th>Freq</th> <th>Level</th> <th>Over Limit</th> <th>Limit Line</th> <th>Read Level</th> <th>LISN Factor</th> <th>Cable Loss</th> <th>Remark</th> </tr> <tr> <th></th> <th>MHz</th> <th>dBuV</th> <th>dB</th> <th>dBuV</th> <th>dBuV</th> <th>dB</th> <th>dB</th> <th></th> </tr> </thead> <tbody> <tr><td>1</td><td>0.1582</td><td>31.07</td><td>-24.49</td><td>55.56</td><td>21.41</td><td>9.63</td><td>0.03</td><td>Average</td></tr> <tr><td>2</td><td>0.1582</td><td>40.42</td><td>-25.14</td><td>65.56</td><td>30.76</td><td>9.63</td><td>0.03</td><td>QP</td></tr> <tr><td>3</td><td>0.3596</td><td>29.73</td><td>-19.01</td><td>48.74</td><td>20.04</td><td>9.61</td><td>0.08</td><td>Average</td></tr> <tr><td>4</td><td>0.3596</td><td>36.35</td><td>-22.39</td><td>58.74</td><td>26.66</td><td>9.61</td><td>0.08</td><td>QP</td></tr> <tr><td>5</td><td>0.4564</td><td>27.83</td><td>-18.93</td><td>46.76</td><td>18.13</td><td>9.61</td><td>0.09</td><td>Average</td></tr> <tr><td>6</td><td>0.4564</td><td>37.58</td><td>-19.18</td><td>56.76</td><td>27.88</td><td>9.61</td><td>0.09</td><td>QP</td></tr> <tr><td>7 MAX</td><td>2.1553</td><td>33.19</td><td>-12.81</td><td>46.00</td><td>23.55</td><td>9.63</td><td>0.01</td><td>Average</td></tr> <tr><td>8</td><td>2.1553</td><td>37.28</td><td>-18.72</td><td>56.00</td><td>27.64</td><td>9.63</td><td>0.01</td><td>QP</td></tr> <tr><td>9</td><td>3.7395</td><td>24.95</td><td>-21.05</td><td>46.00</td><td>15.23</td><td>9.64</td><td>0.08</td><td>Average</td></tr> <tr><td>10</td><td>3.7395</td><td>32.71</td><td>-23.29</td><td>56.00</td><td>22.99</td><td>9.64</td><td>0.08</td><td>QP</td></tr> <tr><td>11</td><td>17.3826</td><td>22.57</td><td>-27.43</td><td>50.00</td><td>12.76</td><td>9.71</td><td>0.10</td><td>Average</td></tr> <tr><td>12</td><td>17.3826</td><td>27.59</td><td>-32.41</td><td>60.00</td><td>17.78</td><td>9.71</td><td>0.10</td><td>QP</td></tr> </tbody> </table> | | | | | Freq | Level | Over Limit | Limit Line | Read Level | LISN Factor | Cable Loss | Remark | | MHz | dBuV | dB | dBuV | dBuV | dB | dB | | 1 | 0.1582 | 31.07 | -24.49 | 55.56 | 21.41 | 9.63 | 0.03 | Average | 2 | 0.1582 | 40.42 | -25.14 | 65.56 | 30.76 | 9.63 | 0.03 | QP | 3 | 0.3596 | 29.73 | -19.01 | 48.74 | 20.04 | 9.61 | 0.08 | Average | 4 | 0.3596 | 36.35 | -22.39 | 58.74 | 26.66 | 9.61 | 0.08 | QP | 5 | 0.4564 | 27.83 | -18.93 | 46.76 | 18.13 | 9.61 | 0.09 | Average | 6 | 0.4564 | 37.58 | -19.18 | 56.76 | 27.88 | 9.61 | 0.09 | QP | 7 MAX | 2.1553 | 33.19 | -12.81 | 46.00 | 23.55 | 9.63 | 0.01 | Average | 8 | 2.1553 | 37.28 | -18.72 | 56.00 | 27.64 | 9.63 | 0.01 | QP | 9 | 3.7395 | 24.95 | -21.05 | 46.00 | 15.23 | 9.64 | 0.08 | Average | 10 | 3.7395 | 32.71 | -23.29 | 56.00 | 22.99 | 9.64 | 0.08 | QP | 11 | 17.3826 | 22.57 | -27.43 | 50.00 | 12.76 | 9.71 | 0.10 | Average | 12 | 17.3826 | 27.59 | -32.41 | 60.00 | 17.78 | 9.71 | 0.10 | QP |
| | Freq | Level | Over Limit | Limit Line | Read Level | LISN Factor | Cable Loss | Remark | | | | | | | | | | | | | | | | | | | | | | | | | | | | | | | | | | | | | | | | | | | | | | | | | | | | | | | | | | | | | | | | | | | | | | | | | | | | | | | | | | | | | | | | | | | | | | | | | | | | | | | | | | | | | | | | | | | | | | | | | |
| | MHz | dBuV | dB | dBuV | dBuV | dB | dB | | | | | | | | | | | | | | | | | | | | | | | | | | | | | | | | | | | | | | | | | | | | | | | | | | | | | | | | | | | | | | | | | | | | | | | | | | | | | | | | | | | | | | | | | | | | | | | | | | | | | | | | | | | | | | | | | | | | | | | | | | |
| 1 | 0.1582 | 31.07 | -24.49 | 55.56 | 21.41 | 9.63 | 0.03 | Average | | | | | | | | | | | | | | | | | | | | | | | | | | | | | | | | | | | | | | | | | | | | | | | | | | | | | | | | | | | | | | | | | | | | | | | | | | | | | | | | | | | | | | | | | | | | | | | | | | | | | | | | | | | | | | | | | | | | | | | | | |
| 2 | 0.1582 | 40.42 | -25.14 | 65.56 | 30.76 | 9.63 | 0.03 | QP | | | | | | | | | | | | | | | | | | | | | | | | | | | | | | | | | | | | | | | | | | | | | | | | | | | | | | | | | | | | | | | | | | | | | | | | | | | | | | | | | | | | | | | | | | | | | | | | | | | | | | | | | | | | | | | | | | | | | | | | | |
| 3 | 0.3596 | 29.73 | -19.01 | 48.74 | 20.04 | 9.61 | 0.08 | Average | | | | | | | | | | | | | | | | | | | | | | | | | | | | | | | | | | | | | | | | | | | | | | | | | | | | | | | | | | | | | | | | | | | | | | | | | | | | | | | | | | | | | | | | | | | | | | | | | | | | | | | | | | | | | | | | | | | | | | | | | |
| 4 | 0.3596 | 36.35 | -22.39 | 58.74 | 26.66 | 9.61 | 0.08 | QP | | | | | | | | | | | | | | | | | | | | | | | | | | | | | | | | | | | | | | | | | | | | | | | | | | | | | | | | | | | | | | | | | | | | | | | | | | | | | | | | | | | | | | | | | | | | | | | | | | | | | | | | | | | | | | | | | | | | | | | | | |
| 5 | 0.4564 | 27.83 | -18.93 | 46.76 | 18.13 | 9.61 | 0.09 | Average | | | | | | | | | | | | | | | | | | | | | | | | | | | | | | | | | | | | | | | | | | | | | | | | | | | | | | | | | | | | | | | | | | | | | | | | | | | | | | | | | | | | | | | | | | | | | | | | | | | | | | | | | | | | | | | | | | | | | | | | | |
| 6 | 0.4564 | 37.58 | -19.18 | 56.76 | 27.88 | 9.61 | 0.09 | QP | | | | | | | | | | | | | | | | | | | | | | | | | | | | | | | | | | | | | | | | | | | | | | | | | | | | | | | | | | | | | | | | | | | | | | | | | | | | | | | | | | | | | | | | | | | | | | | | | | | | | | | | | | | | | | | | | | | | | | | | | |
| 7 MAX | 2.1553 | 33.19 | -12.81 | 46.00 | 23.55 | 9.63 | 0.01 | Average | | | | | | | | | | | | | | | | | | | | | | | | | | | | | | | | | | | | | | | | | | | | | | | | | | | | | | | | | | | | | | | | | | | | | | | | | | | | | | | | | | | | | | | | | | | | | | | | | | | | | | | | | | | | | | | | | | | | | | | | | |
| 8 | 2.1553 | 37.28 | -18.72 | 56.00 | 27.64 | 9.63 | 0.01 | QP | | | | | | | | | | | | | | | | | | | | | | | | | | | | | | | | | | | | | | | | | | | | | | | | | | | | | | | | | | | | | | | | | | | | | | | | | | | | | | | | | | | | | | | | | | | | | | | | | | | | | | | | | | | | | | | | | | | | | | | | | |
| 9 | 3.7395 | 24.95 | -21.05 | 46.00 | 15.23 | 9.64 | 0.08 | Average | | | | | | | | | | | | | | | | | | | | | | | | | | | | | | | | | | | | | | | | | | | | | | | | | | | | | | | | | | | | | | | | | | | | | | | | | | | | | | | | | | | | | | | | | | | | | | | | | | | | | | | | | | | | | | | | | | | | | | | | | |
| 10 | 3.7395 | 32.71 | -23.29 | 56.00 | 22.99 | 9.64 | 0.08 | QP | | | | | | | | | | | | | | | | | | | | | | | | | | | | | | | | | | | | | | | | | | | | | | | | | | | | | | | | | | | | | | | | | | | | | | | | | | | | | | | | | | | | | | | | | | | | | | | | | | | | | | | | | | | | | | | | | | | | | | | | | |
| 11 | 17.3826 | 22.57 | -27.43 | 50.00 | 12.76 | 9.71 | 0.10 | Average | | | | | | | | | | | | | | | | | | | | | | | | | | | | | | | | | | | | | | | | | | | | | | | | | | | | | | | | | | | | | | | | | | | | | | | | | | | | | | | | | | | | | | | | | | | | | | | | | | | | | | | | | | | | | | | | | | | | | | | | | |
| 12 | 17.3826 | 27.59 | -32.41 | 60.00 | 17.78 | 9.71 | 0.10 | QP | | | | | | | | | | | | | | | | | | | | | | | | | | | | | | | | | | | | | | | | | | | | | | | | | | | | | | | | | | | | | | | | | | | | | | | | | | | | | | | | | | | | | | | | | | | | | | | | | | | | | | | | | | | | | | | | | | | | | | | | | |
| <p>Note 1: ">20dB" means emission levels that exceed the level of 20 dB below the applicable limit. Note 2: "N/F" means Nothing Found emissions (No emissions were detected.)</p> | | | | | | | | | | | | | | | | | | | | | | | | | | | | | | | | | | | | | | | | | | | | | | | | | | | | | | | | | | | | | | | | | | | | | | | | | | | | | | | | | | | | | | | | | | | | | | | | | | | | | | | | | | | | | | | | | | | | | | | | | | | | | | | | | |



| AC Power-line Conducted Emissions Result | | | | | | | | | | | | | | | | | | | | | | | | | | | | | | | | | | | | | | | | | | | | | | | | | | | | | | | | | | | | | | | | | | | | | | | | | | | | | | | | | | | | | | | | | | | | | | | | | | | | | | | | | | | | | | | | | | | | | | | | | | | | | | | | | |
|--|----------------------|-------------|------------|------------|------------|-------------|------------|------------|------------|-------------|------------|--------|--|-----|------|----|------|------|----|----|--|---|--------|-------|--------|-------|-------|------|------|---------|---|--------|-------|--------|-------|-------|------|------|----|-------|--------|-------|--------|-------|-------|------|------|---------|---|--------|-------|--------|-------|-------|------|------|----|---|--------|-------|--------|-------|-------|------|------|---------|---|--------|-------|--------|-------|-------|------|------|----|---|--------|-------|--------|-------|------|------|------|---------|---|--------|-------|--------|-------|-------|------|------|----|---|--------|-------|--------|-------|-------|------|------|---------|----|--------|-------|--------|-------|-------|------|------|----|----|---------|-------|--------|-------|-------|------|------|---------|----|---------|-------|--------|-------|-------|------|------|----|
| Operating Mode | 1 | Power Phase | Line | | | | | | | | | | | | | | | | | | | | | | | | | | | | | | | | | | | | | | | | | | | | | | | | | | | | | | | | | | | | | | | | | | | | | | | | | | | | | | | | | | | | | | | | | | | | | | | | | | | | | | | | | | | | | | | | | | | | | | | | | | | | | | |
| Operating Function | USB Mode ; BT 4.0 TX | | | | | | | | | | | | | | | | | | | | | | | | | | | | | | | | | | | | | | | | | | | | | | | | | | | | | | | | | | | | | | | | | | | | | | | | | | | | | | | | | | | | | | | | | | | | | | | | | | | | | | | | | | | | | | | | | | | | | | | | | | | | | | | | |
| <p>The graph displays the AC power-line conducted emissions. The y-axis represents Level in dBuV, ranging from 0 to 80. The x-axis represents Frequency in MHz, ranging from 0.150.2 to 30. Two red lines indicate the limits: NCC/IC/FCC-B (upper) and NCC/IC/FCC-B-AV (lower). A blue line shows the measured emission levels, which are generally below the limits, with a notable peak at 0.4148 MHz.</p> | | | | | | | | | | | | | | | | | | | | | | | | | | | | | | | | | | | | | | | | | | | | | | | | | | | | | | | | | | | | | | | | | | | | | | | | | | | | | | | | | | | | | | | | | | | | | | | | | | | | | | | | | | | | | | | | | | | | | | | | | | | | | | | | | |
| <table border="1"> <thead> <tr> <th></th> <th>Freq</th> <th>Level</th> <th>Over Limit</th> <th>Limit Line</th> <th>Read Level</th> <th>LISN Factor</th> <th>Cable Loss</th> <th>Remark</th> </tr> <tr> <th></th> <th>MHz</th> <th>dBuV</th> <th>dB</th> <th>dBuV</th> <th>dBuV</th> <th>dB</th> <th>dB</th> <th></th> </tr> </thead> <tbody> <tr> <td>1</td> <td>0.1532</td> <td>29.44</td> <td>-26.38</td> <td>55.82</td> <td>19.78</td> <td>9.62</td> <td>0.04</td> <td>Average</td> </tr> <tr> <td>2</td> <td>0.1532</td> <td>38.41</td> <td>-27.41</td> <td>65.82</td> <td>28.75</td> <td>9.62</td> <td>0.04</td> <td>QP</td> </tr> <tr> <td>3 MAX</td> <td>0.4148</td> <td>36.98</td> <td>-10.57</td> <td>47.55</td> <td>27.27</td> <td>9.61</td> <td>0.10</td> <td>Average</td> </tr> <tr> <td>4</td> <td>0.4148</td> <td>38.60</td> <td>-18.95</td> <td>57.55</td> <td>28.89</td> <td>9.61</td> <td>0.10</td> <td>QP</td> </tr> <tr> <td>5</td> <td>0.4539</td> <td>27.10</td> <td>-19.70</td> <td>46.80</td> <td>17.40</td> <td>9.61</td> <td>0.09</td> <td>Average</td> </tr> <tr> <td>6</td> <td>0.4539</td> <td>31.18</td> <td>-25.62</td> <td>56.80</td> <td>21.48</td> <td>9.61</td> <td>0.09</td> <td>QP</td> </tr> <tr> <td>7</td> <td>1.7162</td> <td>19.15</td> <td>-26.85</td> <td>46.00</td> <td>9.53</td> <td>9.62</td> <td>0.00</td> <td>Average</td> </tr> <tr> <td>8</td> <td>1.7162</td> <td>24.96</td> <td>-31.04</td> <td>56.00</td> <td>15.34</td> <td>9.62</td> <td>0.00</td> <td>QP</td> </tr> <tr> <td>9</td> <td>2.3213</td> <td>25.56</td> <td>-20.44</td> <td>46.00</td> <td>15.92</td> <td>9.62</td> <td>0.02</td> <td>Average</td> </tr> <tr> <td>10</td> <td>2.3213</td> <td>33.46</td> <td>-22.54</td> <td>56.00</td> <td>23.82</td> <td>9.62</td> <td>0.02</td> <td>QP</td> </tr> <tr> <td>11</td> <td>19.3257</td> <td>20.12</td> <td>-29.88</td> <td>50.00</td> <td>10.32</td> <td>9.62</td> <td>0.18</td> <td>Average</td> </tr> <tr> <td>12</td> <td>19.3257</td> <td>25.86</td> <td>-34.14</td> <td>60.00</td> <td>16.06</td> <td>9.62</td> <td>0.18</td> <td>QP</td> </tr> </tbody> </table> | | | | | Freq | Level | Over Limit | Limit Line | Read Level | LISN Factor | Cable Loss | Remark | | MHz | dBuV | dB | dBuV | dBuV | dB | dB | | 1 | 0.1532 | 29.44 | -26.38 | 55.82 | 19.78 | 9.62 | 0.04 | Average | 2 | 0.1532 | 38.41 | -27.41 | 65.82 | 28.75 | 9.62 | 0.04 | QP | 3 MAX | 0.4148 | 36.98 | -10.57 | 47.55 | 27.27 | 9.61 | 0.10 | Average | 4 | 0.4148 | 38.60 | -18.95 | 57.55 | 28.89 | 9.61 | 0.10 | QP | 5 | 0.4539 | 27.10 | -19.70 | 46.80 | 17.40 | 9.61 | 0.09 | Average | 6 | 0.4539 | 31.18 | -25.62 | 56.80 | 21.48 | 9.61 | 0.09 | QP | 7 | 1.7162 | 19.15 | -26.85 | 46.00 | 9.53 | 9.62 | 0.00 | Average | 8 | 1.7162 | 24.96 | -31.04 | 56.00 | 15.34 | 9.62 | 0.00 | QP | 9 | 2.3213 | 25.56 | -20.44 | 46.00 | 15.92 | 9.62 | 0.02 | Average | 10 | 2.3213 | 33.46 | -22.54 | 56.00 | 23.82 | 9.62 | 0.02 | QP | 11 | 19.3257 | 20.12 | -29.88 | 50.00 | 10.32 | 9.62 | 0.18 | Average | 12 | 19.3257 | 25.86 | -34.14 | 60.00 | 16.06 | 9.62 | 0.18 | QP |
| | Freq | Level | Over Limit | Limit Line | Read Level | LISN Factor | Cable Loss | Remark | | | | | | | | | | | | | | | | | | | | | | | | | | | | | | | | | | | | | | | | | | | | | | | | | | | | | | | | | | | | | | | | | | | | | | | | | | | | | | | | | | | | | | | | | | | | | | | | | | | | | | | | | | | | | | | | | | | | | | | | | |
| | MHz | dBuV | dB | dBuV | dBuV | dB | dB | | | | | | | | | | | | | | | | | | | | | | | | | | | | | | | | | | | | | | | | | | | | | | | | | | | | | | | | | | | | | | | | | | | | | | | | | | | | | | | | | | | | | | | | | | | | | | | | | | | | | | | | | | | | | | | | | | | | | | | | | | |
| 1 | 0.1532 | 29.44 | -26.38 | 55.82 | 19.78 | 9.62 | 0.04 | Average | | | | | | | | | | | | | | | | | | | | | | | | | | | | | | | | | | | | | | | | | | | | | | | | | | | | | | | | | | | | | | | | | | | | | | | | | | | | | | | | | | | | | | | | | | | | | | | | | | | | | | | | | | | | | | | | | | | | | | | | | |
| 2 | 0.1532 | 38.41 | -27.41 | 65.82 | 28.75 | 9.62 | 0.04 | QP | | | | | | | | | | | | | | | | | | | | | | | | | | | | | | | | | | | | | | | | | | | | | | | | | | | | | | | | | | | | | | | | | | | | | | | | | | | | | | | | | | | | | | | | | | | | | | | | | | | | | | | | | | | | | | | | | | | | | | | | | |
| 3 MAX | 0.4148 | 36.98 | -10.57 | 47.55 | 27.27 | 9.61 | 0.10 | Average | | | | | | | | | | | | | | | | | | | | | | | | | | | | | | | | | | | | | | | | | | | | | | | | | | | | | | | | | | | | | | | | | | | | | | | | | | | | | | | | | | | | | | | | | | | | | | | | | | | | | | | | | | | | | | | | | | | | | | | | | |
| 4 | 0.4148 | 38.60 | -18.95 | 57.55 | 28.89 | 9.61 | 0.10 | QP | | | | | | | | | | | | | | | | | | | | | | | | | | | | | | | | | | | | | | | | | | | | | | | | | | | | | | | | | | | | | | | | | | | | | | | | | | | | | | | | | | | | | | | | | | | | | | | | | | | | | | | | | | | | | | | | | | | | | | | | | |
| 5 | 0.4539 | 27.10 | -19.70 | 46.80 | 17.40 | 9.61 | 0.09 | Average | | | | | | | | | | | | | | | | | | | | | | | | | | | | | | | | | | | | | | | | | | | | | | | | | | | | | | | | | | | | | | | | | | | | | | | | | | | | | | | | | | | | | | | | | | | | | | | | | | | | | | | | | | | | | | | | | | | | | | | | | |
| 6 | 0.4539 | 31.18 | -25.62 | 56.80 | 21.48 | 9.61 | 0.09 | QP | | | | | | | | | | | | | | | | | | | | | | | | | | | | | | | | | | | | | | | | | | | | | | | | | | | | | | | | | | | | | | | | | | | | | | | | | | | | | | | | | | | | | | | | | | | | | | | | | | | | | | | | | | | | | | | | | | | | | | | | | |
| 7 | 1.7162 | 19.15 | -26.85 | 46.00 | 9.53 | 9.62 | 0.00 | Average | | | | | | | | | | | | | | | | | | | | | | | | | | | | | | | | | | | | | | | | | | | | | | | | | | | | | | | | | | | | | | | | | | | | | | | | | | | | | | | | | | | | | | | | | | | | | | | | | | | | | | | | | | | | | | | | | | | | | | | | | |
| 8 | 1.7162 | 24.96 | -31.04 | 56.00 | 15.34 | 9.62 | 0.00 | QP | | | | | | | | | | | | | | | | | | | | | | | | | | | | | | | | | | | | | | | | | | | | | | | | | | | | | | | | | | | | | | | | | | | | | | | | | | | | | | | | | | | | | | | | | | | | | | | | | | | | | | | | | | | | | | | | | | | | | | | | | |
| 9 | 2.3213 | 25.56 | -20.44 | 46.00 | 15.92 | 9.62 | 0.02 | Average | | | | | | | | | | | | | | | | | | | | | | | | | | | | | | | | | | | | | | | | | | | | | | | | | | | | | | | | | | | | | | | | | | | | | | | | | | | | | | | | | | | | | | | | | | | | | | | | | | | | | | | | | | | | | | | | | | | | | | | | | |
| 10 | 2.3213 | 33.46 | -22.54 | 56.00 | 23.82 | 9.62 | 0.02 | QP | | | | | | | | | | | | | | | | | | | | | | | | | | | | | | | | | | | | | | | | | | | | | | | | | | | | | | | | | | | | | | | | | | | | | | | | | | | | | | | | | | | | | | | | | | | | | | | | | | | | | | | | | | | | | | | | | | | | | | | | | |
| 11 | 19.3257 | 20.12 | -29.88 | 50.00 | 10.32 | 9.62 | 0.18 | Average | | | | | | | | | | | | | | | | | | | | | | | | | | | | | | | | | | | | | | | | | | | | | | | | | | | | | | | | | | | | | | | | | | | | | | | | | | | | | | | | | | | | | | | | | | | | | | | | | | | | | | | | | | | | | | | | | | | | | | | | | |
| 12 | 19.3257 | 25.86 | -34.14 | 60.00 | 16.06 | 9.62 | 0.18 | QP | | | | | | | | | | | | | | | | | | | | | | | | | | | | | | | | | | | | | | | | | | | | | | | | | | | | | | | | | | | | | | | | | | | | | | | | | | | | | | | | | | | | | | | | | | | | | | | | | | | | | | | | | | | | | | | | | | | | | | | | | |
| <p>Note 1: ">20dB" means emission levels that exceed the level of 20 dB below the applicable limit. Note 2: "N/F" means Nothing Found emissions (No emissions were detected.)</p> | | | | | | | | | | | | | | | | | | | | | | | | | | | | | | | | | | | | | | | | | | | | | | | | | | | | | | | | | | | | | | | | | | | | | | | | | | | | | | | | | | | | | | | | | | | | | | | | | | | | | | | | | | | | | | | | | | | | | | | | | | | | | | | | | |



Summary

| Mode | Max-N dB (Hz) | Max-OBW (Hz) | ITU-Code | Min-N dB (Hz) | Min-OBW (Hz) |
|---------------|------------------|-----------------|----------|------------------|-----------------|
| 2.4-2.4835GHz | - | - | - | - | - |
| BT-LE(1Mbps) | 658.75k | 1.018M | 1M02F1D | 657.5k | 1.014M |

Max-N dB = Maximum 6dB down bandwidth; **Max-OBW** = Maximum 99% occupied bandwidth;
Min-N dB = Minimum 6dB down bandwidth; **Min-OBW** = Minimum 99% occupied bandwidth;

Result

| Mode | Result | Limit (Hz) | Port 1-N dB (Hz) | Port 1-OBW (Hz) |
|--------------|--------|---------------|---------------------|--------------------|
| BT-LE(1Mbps) | - | - | - | - |
| 2402MHz | Pass | 500k | 657.5k | 1.018M |
| 2440MHz | Pass | 500k | 657.5k | 1.014M |
| 2480MHz | Pass | 500k | 658.75k | 1.016M |

Port X-N dB = Port X 6dB down bandwidth; **Port X-OBW** = Port X 99% occupied bandwidth;

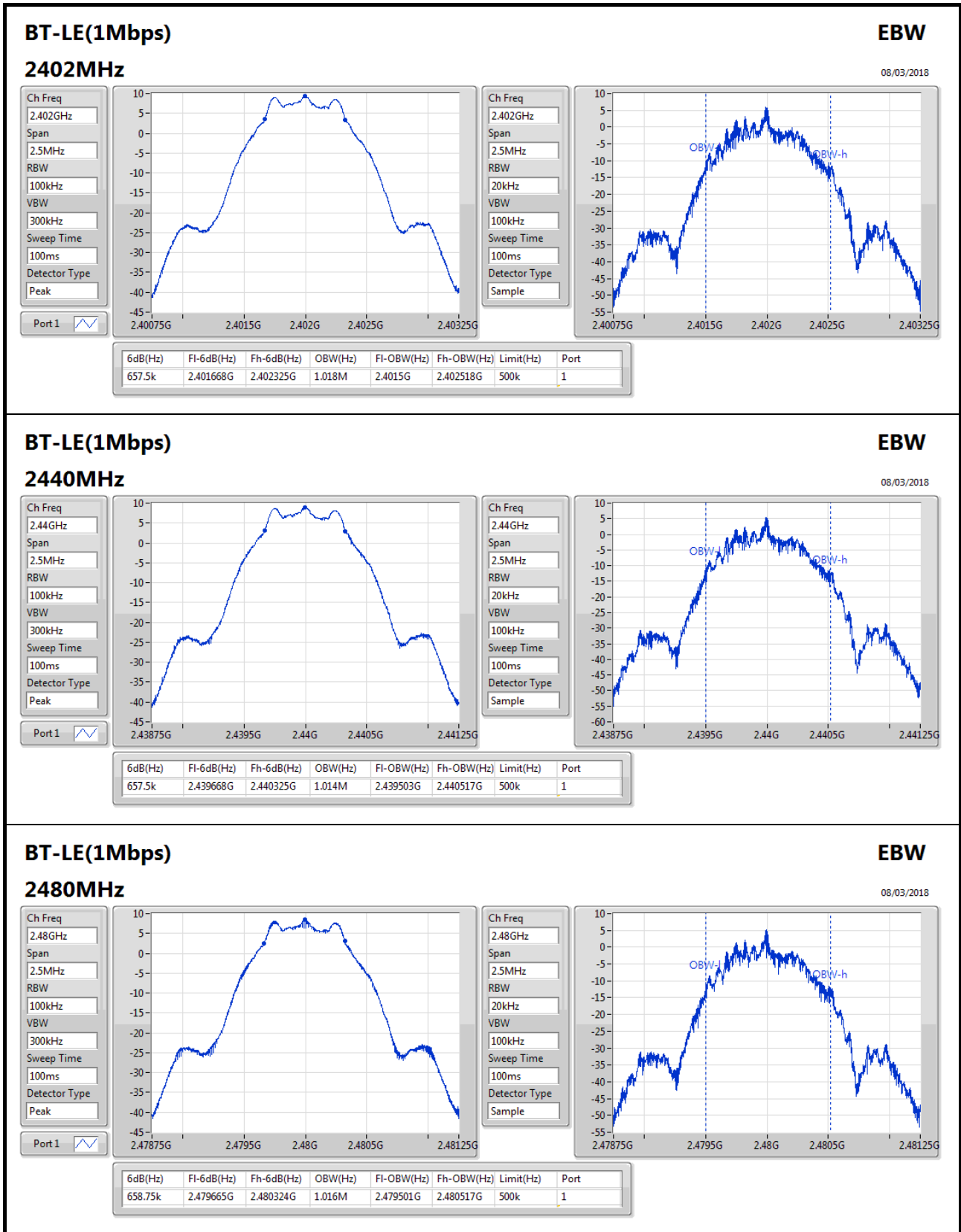
BT-LE(1Mbps)
EBW

08/03/2018

2480MHz

Ch Freq: 2.48GHz
Span: 2.5MHz
RBW: 100kHz
VBW: 300kHz
Sweep Time: 100ms
Detector Type: Peak

Ch Freq: 2.48GHz
Span: 2.5MHz
RBW: 20kHz
VBW: 100kHz
Sweep Time: 100ms
Detector Type: Sample



Summary

| Mode | Power (dBm) | Power (W) |
|---------------|----------------|--------------|
| 2.4-2.4835GHz | - | - |
| BT-LE(1Mbps) | 8.78 | 0.00755 |

Result

| Mode | Result | Gain (dBi) | Power (dBm) | Power Limit (dBm) |
|--------------|--------|---------------|----------------|----------------------|
| BT-LE(1Mbps) | - | - | - | - |
| 2402MHz | Pass | 2.15 | 8.78 | 30.00 |
| 2440MHz | Pass | 2.15 | 8.42 | 30.00 |
| 2480MHz | Pass | 2.15 | 7.94 | 30.00 |



Summary

| Mode | PD (dBm/RBW) |
|---------------|-----------------|
| 2.4-2.4835GHz | - |
| BT-LE(1Mbps) | -5.59 |

RBW=3kHz.

Result

| Mode | Result | Gain (dBi) | PD (dBm/RBW) | PD Limit (dBm/RBW) |
|--------------|--------|---------------|-----------------|-----------------------|
| BT-LE(1Mbps) | - | - | - | - |
| 2402MHz | Pass | 2.15 | -5.59 | 8.00 |
| 2440MHz | Pass | 2.15 | -5.81 | 8.00 |
| 2480MHz | Pass | 2.15 | -6.53 | 8.00 |

RBW=3kHz.

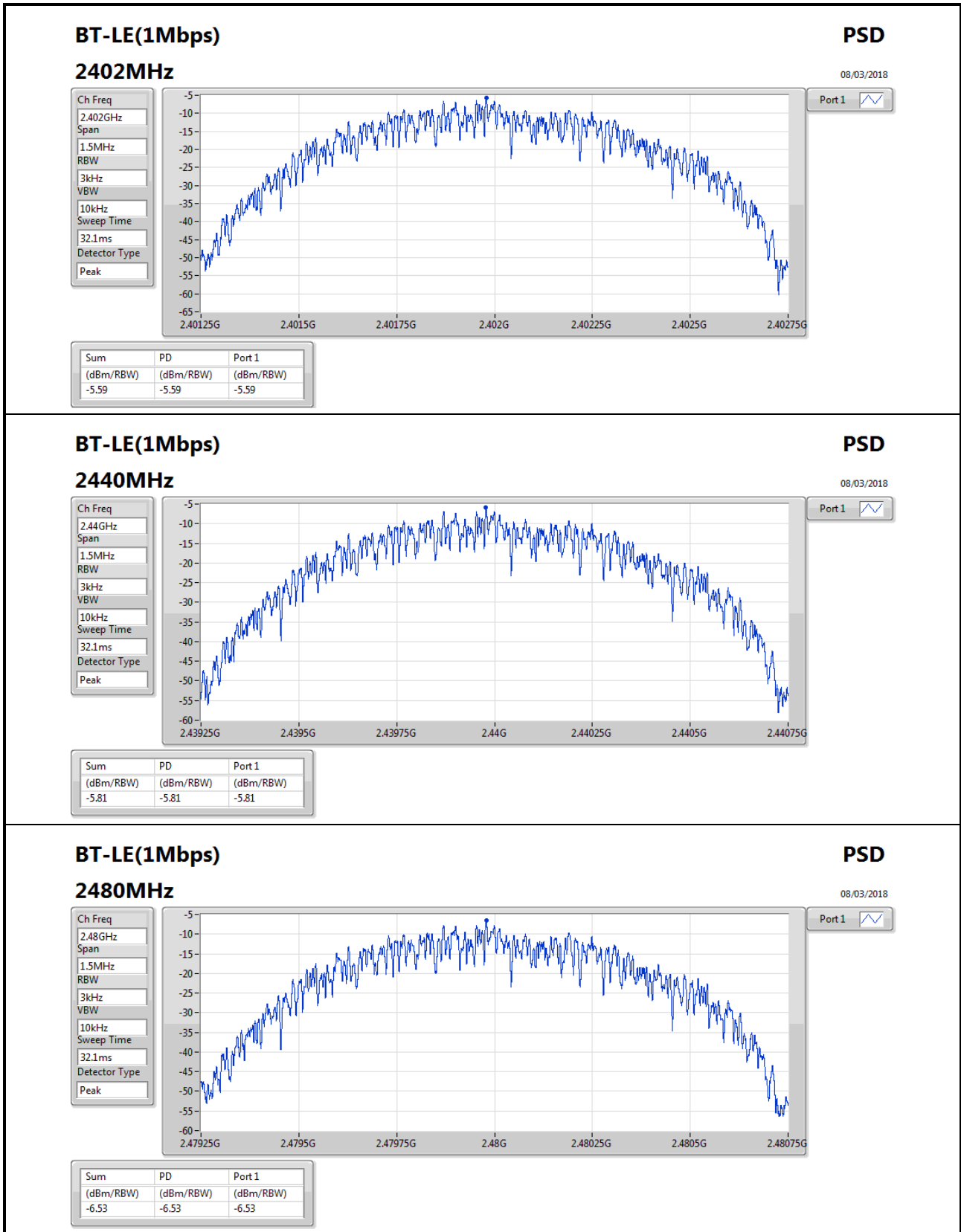



Summary

| Mode | Result | Ref (Hz) | Ref (dBm) | Limit (dBm) | Freq (Hz) | Level (dBm) | Freq (Hz) | Level (dBm) | Freq (Hz) | Level (dBm) | Freq (Hz) | Level (dBm) | Port |
|---------------|--------|-------------|--------------|----------------|--------------|----------------|--------------|----------------|--------------|----------------|--------------|----------------|------|
| 2.4-2.4835GHz | - | - | - | - | - | - | - | - | - | - | - | - | - |
| BT-LE(1Mbps) | Pass | 2.401837G | 9.22 | -20.78 | 2.396816G | -55.20 | 2.3997G | -48.01 | 2.48482G | -58.47 | 6.996843G | -53.42 | 1 |

Result

| Mode | Result | Ref (Hz) | Ref (dBm) | Limit (dBm) | Freq (Hz) | Level (dBm) | Freq (Hz) | Level (dBm) | Freq (Hz) | Level (dBm) | Freq (Hz) | Level (dBm) | Port |
|--------------|--------|-------------|--------------|----------------|--------------|----------------|--------------|----------------|--------------|----------------|--------------|----------------|------|
| BT-LE(1Mbps) | - | - | - | - | - | - | - | - | - | - | - | - | - |
| 2402MHz | Pass | 2.401837G | 9.22 | -20.78 | 2.396816G | -55.20 | 2.3997G | -48.01 | 2.48482G | -58.47 | 6.996843G | -53.42 | 1 |
| 2440MHz | Pass | 2.401837G | 9.22 | -20.78 | 812.624M | -55.69 | 2.399156G | -58.13 | 2.484548G | -57.92 | 6.982771G | -53.32 | 1 |
| 2480MHz | Pass | 2.401837G | 9.22 | -20.78 | 826.832M | -57.54 | 2.399156G | -59.08 | 2.483904G | -50.53 | 6.262307G | -53.21 | 1 |

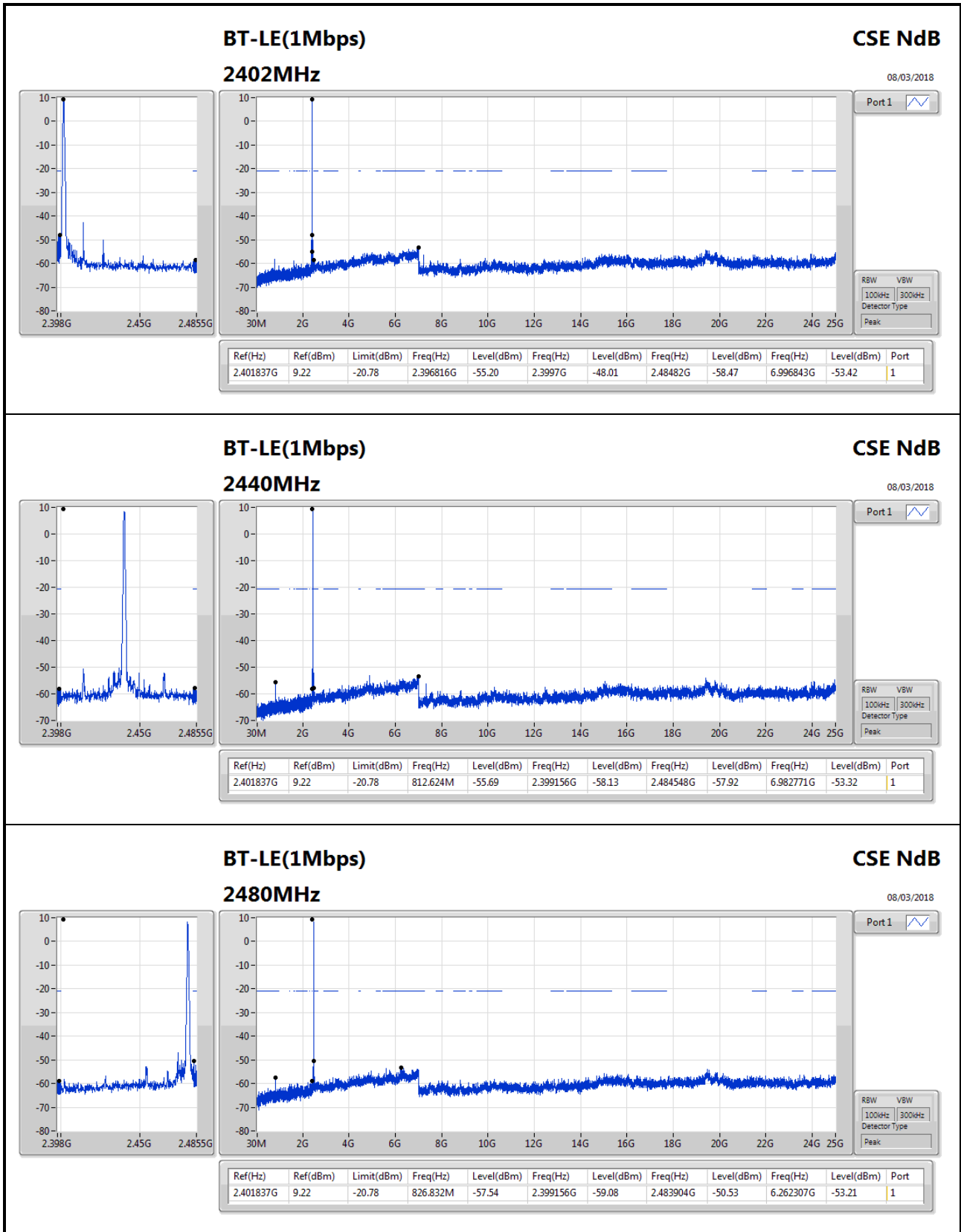

BT-LE(1Mbps)

2480MHz

CSE NdB

08/03/2018

Port1

| Ref(Hz) | Ref(dBm) | Limit(dBm) | Freq(Hz) | Level(dBm) | Freq(Hz) | Level(dBm) | Freq(Hz) | Level(dBm) | Freq(Hz) | Level(dBm) | Port |
|-----------|----------|------------|----------|------------|-----------|------------|-----------|------------|-----------|------------|------|
| 2.401837G | 9.22 | -20.78 | 826.832M | -57.54 | 2.399156G | -59.08 | 2.483904G | -50.53 | 6.262307G | -53.21 | 1 |



Summary

| Mode | Result | Type | Freq (Hz) | Level (dBuV/m) | Limit (dBuV/m) | Margin (dB) | Factor (dB) | Dist (m) | Condition | Azimuth (°) | Height (m) | Comments |
|---------------|--------|------|-----------|----------------|----------------|-------------|-------------|----------|------------|-------------|------------|----------|
| 2.4-2.4835GHz | - | - | - | - | - | - | - | - | - | - | - | - |
| BT-LE(1Mbps) | Pass | PK | 266.68M | 40.52 | 46.00 | -5.48 | -6.01 | 3 | Horizontal | 0 | 2.00 | - |



Result

| Mode | Result | Type | Freq (Hz) | Level (dBuV/m) | Limit (dBuV/m) | Margin (dB) | Factor (dB) | Dist (m) | Condition | Azimuth (°) | Height (m) | Comments |
|--------------|--------|------|-----------|----------------|----------------|-------------|-------------|----------|------------|-------------|------------|----------|
| BT-LE(1Mbps) | - | - | - | - | - | - | - | - | - | - | - | - |
| 2440MHz | Pass | PK | 171.62M | 33.23 | 43.50 | -10.27 | -9.85 | 3 | Horizontal | 0 | 2.00 | - |
| 2440MHz | Pass | PK | 198.78M | 36.44 | 43.50 | -7.06 | -10.04 | 3 | Horizontal | 0 | 2.00 | - |
| 2440MHz | Pass | PK | 266.68M | 40.52 | 46.00 | -5.48 | -6.01 | 3 | Horizontal | 0 | 2.00 | - |
| 2440MHz | Pass | PK | 332.64M | 32.60 | 46.00 | -13.40 | -5.21 | 3 | Horizontal | 0 | 2.00 | - |
| 2440MHz | Pass | PK | 344.28M | 34.67 | 46.00 | -11.33 | -4.86 | 3 | Horizontal | 0 | 2.00 | - |
| 2440MHz | Pass | PK | 383.08M | 32.74 | 46.00 | -13.26 | -4.09 | 3 | Horizontal | 0 | 2.00 | - |
| 2440MHz | Pass | PK | 154.16M | 32.44 | 43.50 | -11.06 | -9.79 | 3 | Vertical | 360 | 1.00 | - |
| 2440MHz | Pass | PK | 171.62M | 35.66 | 43.50 | -7.84 | -9.85 | 3 | Vertical | 360 | 1.00 | - |
| 2440MHz | Pass | PK | 264.74M | 33.65 | 46.00 | -12.35 | -5.89 | 3 | Vertical | 360 | 1.00 | - |
| 2440MHz | Pass | PK | 470.38M | 31.12 | 46.00 | -14.88 | -1.82 | 3 | Vertical | 360 | 1.00 | - |
| 2440MHz | Pass | PK | 532.46M | 30.42 | 46.00 | -15.58 | -0.93 | 3 | Vertical | 360 | 1.00 | - |
| 2440MHz | Pass | PK | 712.88M | 33.07 | 46.00 | -12.93 | 0.51 | 3 | Vertical | 360 | 1.00 | - |



BT-LE(1Mbps)

2440MHz_USB

11/03/2018

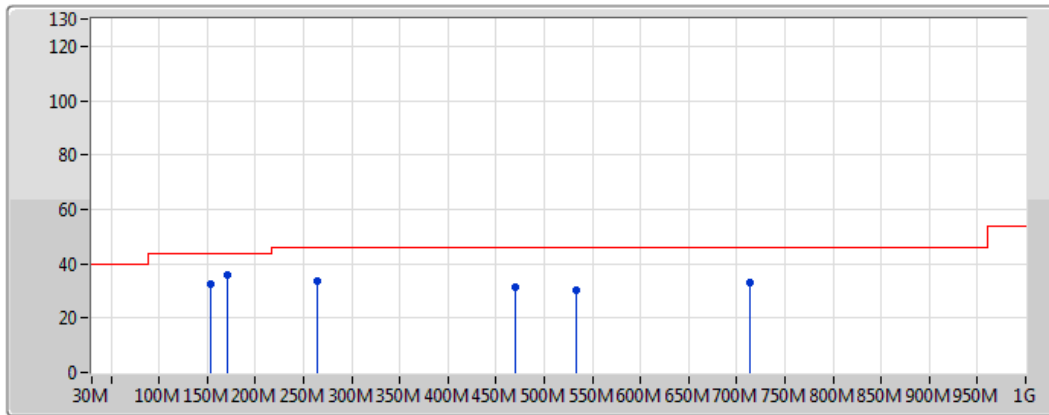

Legend for the spectrum plot:

- Lim.PK: Red line with a red zigzag icon
- PK: Blue line with a blue zigzag icon

| Type | Freq (Hz) | Level (dBuV/m) | Limit (dBuV/m) | Margin (dB) | Factor (dB) | Dist (m) | Condition | Azimuth (°) | Height (m) | Comments | Raw (dBuV) | AF (dB) | CL (dB) | PA (dB) |
|------|-----------|----------------|----------------|-------------|-------------|----------|-----------|-------------|------------|----------|------------|---------|---------|---------|
| PK | 154.16M | 32.44 | 43.50 | -11.06 | -9.79 | 3 | Vertical | 360 | 1.00 | - | 42.23 | 15.19 | 2.13 | 27.12 |
| PK | 171.62M | 35.66 | 43.50 | -7.84 | -9.85 | 3 | Vertical | 360 | 1.00 | - | 45.51 | 14.68 | 2.52 | 27.04 |
| PK | 264.74M | 33.65 | 46.00 | -12.35 | -5.89 | 3 | Vertical | 360 | 1.00 | - | 39.54 | 18.47 | 2.40 | 26.76 |
| PK | 470.38M | 31.12 | 46.00 | -14.88 | -1.82 | 3 | Vertical | 360 | 1.00 | - | 32.94 | 22.38 | 3.47 | 27.67 |
| PK | 532.46M | 30.42 | 46.00 | -15.58 | -0.93 | 3 | Vertical | 360 | 1.00 | - | 31.35 | 23.33 | 3.62 | 27.88 |
| PK | 712.88M | 33.07 | 46.00 | -12.93 | 0.51 | 3 | Vertical | 360 | 1.00 | - | 32.56 | 24.25 | 4.18 | 27.92 |



BT-LE(1Mbps)

2440MHz_USB

11/03/2018

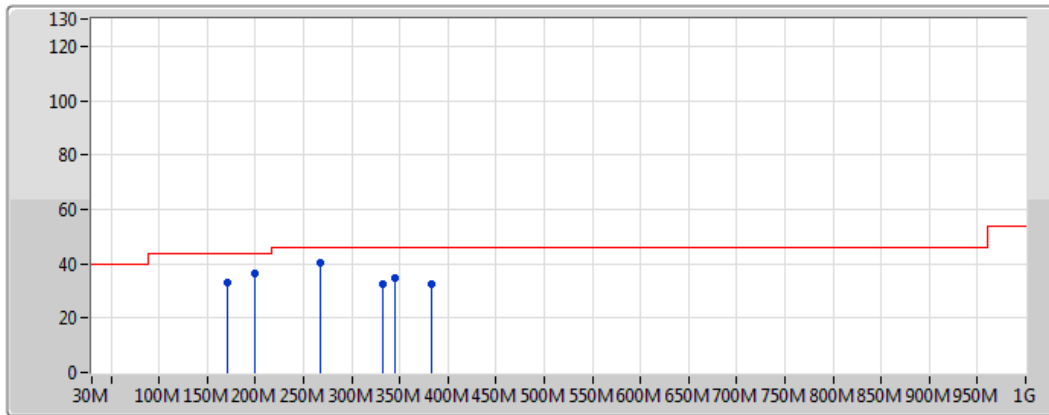

Legend:

- Lim.PK (Red line with square)
- PK (Blue line with square)

| Type | Freq (Hz) | Level (dBuV/m) | Limit (dBuV/m) | Margin (dB) | Factor (dB) | Dist (m) | Condition | Azimuth (°) | Height (m) | Comments | Raw (dBuV) | AF (dB) | CL (dB) | PA (dB) |
|------|-----------|----------------|----------------|-------------|-------------|----------|------------|-------------|------------|----------|------------|---------|---------|---------|
| PK | 171.62M | 33.23 | 43.50 | -10.27 | -9.85 | 3 | Horizontal | 0 | 2.00 | - | 43.08 | 14.68 | 2.52 | 27.04 |
| PK | 198.78M | 36.44 | 43.50 | -7.06 | -10.04 | 3 | Horizontal | 0 | 2.00 | - | 46.48 | 14.39 | 2.48 | 26.92 |
| PK | 266.68M | 40.52 | 46.00 | -5.48 | -6.01 | 3 | Horizontal | 0 | 2.00 | - | 46.53 | 18.31 | 2.44 | 26.76 |
| PK | 332.64M | 32.60 | 46.00 | -13.40 | -5.21 | 3 | Horizontal | 0 | 2.00 | - | 37.81 | 18.89 | 2.77 | 26.88 |
| PK | 344.28M | 34.67 | 46.00 | -11.33 | -4.86 | 3 | Horizontal | 0 | 2.00 | - | 39.53 | 19.18 | 2.91 | 26.95 |
| PK | 383.08M | 32.74 | 46.00 | -13.26 | -4.09 | 3 | Horizontal | 0 | 2.00 | - | 36.83 | 20.07 | 3.03 | 27.19 |



Summary

| Mode | Result | Type | Freq (Hz) | Level (dBuV/m) | Limit (dBuV/m) | Margin (dB) | Factor (dB) | Dist (m) | Condition | Azimuth (°) | Height (m) | Comments |
|---------------|--------|------|-----------|----------------|----------------|-------------|-------------|----------|-----------|-------------|------------|----------|
| 2.4-2.4835GHz | - | - | - | - | - | - | - | - | - | - | - | - |
| BT-LE(1Mbps) | Pass | AV | 4.80394G | 50.16 | 54.00 | -3.84 | 5.85 | 3 | Vertical | 184 | 1.75 | - |



Result

| Mode | Result | Type | Freq (Hz) | Level (dBuV/m) | Limit (dBuV/m) | Margin (dB) | Factor (dB) | Dist (m) | Condition | Azimuth (°) | Height (m) | Comments |
|--------------|--------|------|-----------|----------------|----------------|-------------|-------------|----------|------------|-------------|------------|----------|
| BT-LE(1Mbps) | - | - | - | - | - | - | - | - | - | - | - | - |
| 2402MHz | Pass | AV | 2.3894G | 46.73 | 54.00 | -7.27 | 30.45 | 3 | Horizontal | 102 | 1.44 | - |
| 2402MHz | Pass | AV | 2.402G | 103.17 | Inf | -Inf | 30.50 | 3 | Horizontal | 102 | 1.44 | - |
| 2402MHz | Pass | PK | 2.3768G | 58.53 | 74.00 | -15.47 | 30.41 | 3 | Horizontal | 102 | 1.44 | - |
| 2402MHz | Pass | PK | 2.4022G | 103.61 | Inf | -Inf | 30.50 | 3 | Horizontal | 102 | 1.44 | - |
| 2402MHz | Pass | AV | 2.3866G | 47.87 | 54.00 | -6.13 | 30.45 | 3 | Vertical | 84 | 2.56 | - |
| 2402MHz | Pass | AV | 2.402G | 107.73 | Inf | -Inf | 30.50 | 3 | Vertical | 84 | 2.56 | - |
| 2402MHz | Pass | PK | 2.3766G | 61.72 | 74.00 | -12.28 | 30.41 | 3 | Vertical | 84 | 2.56 | - |
| 2402MHz | Pass | PK | 2.402G | 108.13 | Inf | -Inf | 30.50 | 3 | Vertical | 84 | 2.56 | - |
| 2402MHz | Pass | AV | 4.80402G | 46.45 | 54.00 | -7.55 | 5.85 | 3 | Horizontal | 205 | 1.51 | - |
| 2402MHz | Pass | PK | 4.80438G | 51.94 | 74.00 | -22.06 | 5.85 | 3 | Horizontal | 205 | 1.51 | - |
| 2402MHz | Pass | AV | 4.80394G | 50.16 | 54.00 | -3.84 | 5.85 | 3 | Vertical | 184 | 1.75 | - |
| 2402MHz | Pass | PK | 4.80356G | 54.83 | 74.00 | -19.17 | 5.85 | 3 | Vertical | 184 | 1.75 | - |
| 2440MHz | Pass | AV | 2.3464G | 46.94 | 54.00 | -7.06 | 30.30 | 3 | Horizontal | 96 | 1.07 | - |
| 2440MHz | Pass | AV | 2.44G | 102.32 | Inf | -Inf | 30.63 | 3 | Horizontal | 96 | 1.07 | - |
| 2440MHz | Pass | AV | 2.488G | 48.00 | 54.00 | -6.00 | 30.81 | 3 | Horizontal | 96 | 1.07 | - |
| 2440MHz | Pass | PK | 2.3536G | 58.16 | 74.00 | -15.84 | 30.33 | 3 | Horizontal | 96 | 1.07 | - |
| 2440MHz | Pass | PK | 2.4396G | 102.77 | Inf | -Inf | 30.63 | 3 | Horizontal | 96 | 1.07 | - |
| 2440MHz | Pass | PK | 2.49998G | 58.76 | 74.00 | -15.24 | 30.85 | 3 | Horizontal | 96 | 1.07 | - |
| 2440MHz | Pass | AV | 2.38998G | 46.99 | 54.00 | -7.01 | 30.45 | 3 | Vertical | 81 | 2.62 | - |
| 2440MHz | Pass | AV | 2.44G | 106.54 | Inf | -Inf | 30.63 | 3 | Vertical | 81 | 2.62 | - |
| 2440MHz | Pass | AV | 2.4928G | 48.00 | 54.00 | -6.00 | 30.82 | 3 | Vertical | 81 | 2.62 | - |
| 2440MHz | Pass | PK | 2.3888G | 60.63 | 74.00 | -13.37 | 30.45 | 3 | Vertical | 81 | 2.62 | - |
| 2440MHz | Pass | PK | 2.4396G | 107.00 | Inf | -Inf | 30.63 | 3 | Vertical | 81 | 2.62 | - |
| 2440MHz | Pass | PK | 2.4908G | 58.74 | 74.00 | -15.26 | 30.82 | 3 | Vertical | 81 | 2.62 | - |
| 2440MHz | Pass | AV | 4.88004G | 40.86 | 54.00 | -13.14 | 6.02 | 3 | Horizontal | 206 | 1.13 | - |
| 2440MHz | Pass | PK | 4.8805G | 48.39 | 74.00 | -25.61 | 6.03 | 3 | Horizontal | 206 | 1.13 | - |
| 2440MHz | Pass | AV | 4.87998G | 41.91 | 54.00 | -12.09 | 6.02 | 3 | Vertical | 182 | 1.99 | - |
| 2440MHz | Pass | PK | 4.87972G | 49.10 | 74.00 | -24.90 | 6.02 | 3 | Vertical | 182 | 1.99 | - |
| 2480MHz | Pass | AV | 2.48G | 103.40 | Inf | -Inf | 30.78 | 3 | Horizontal | 95 | 1.07 | - |
| 2480MHz | Pass | AV | 2.483502G | 48.45 | 54.00 | -5.55 | 30.79 | 3 | Horizontal | 95 | 1.07 | - |
| 2480MHz | Pass | PK | 2.4798G | 103.83 | Inf | -Inf | 30.78 | 3 | Horizontal | 95 | 1.07 | - |
| 2480MHz | Pass | PK | 2.4844G | 58.51 | 74.00 | -15.49 | 30.79 | 3 | Horizontal | 95 | 1.07 | - |
| 2480MHz | Pass | AV | 2.48G | 107.12 | Inf | -Inf | 30.78 | 3 | Vertical | 82 | 2.37 | - |
| 2480MHz | Pass | AV | 2.4864G | 49.93 | 54.00 | -4.07 | 30.80 | 3 | Vertical | 82 | 2.37 | - |
| 2480MHz | Pass | PK | 2.48G | 107.56 | Inf | -Inf | 30.78 | 3 | Vertical | 82 | 2.37 | - |
| 2480MHz | Pass | PK | 2.483502G | 60.52 | 74.00 | -13.48 | 30.79 | 3 | Vertical | 82 | 2.37 | - |
| 2480MHz | Pass | AV | 4.95976G | 45.20 | 54.00 | -8.80 | 6.21 | 3 | Horizontal | 206 | 1.08 | - |
| 2480MHz | Pass | PK | 4.95956G | 51.96 | 74.00 | -22.04 | 6.21 | 3 | Horizontal | 206 | 1.08 | - |
| 2480MHz | Pass | AV | 4.95986G | 49.04 | 54.00 | -4.96 | 6.21 | 3 | Vertical | 153 | 1.89 | - |
| 2480MHz | Pass | PK | 4.96048G | 54.19 | 74.00 | -19.81 | 6.21 | 3 | Vertical | 153 | 1.89 | - |



BT-LE(1Mbps)

2402MHz_TX

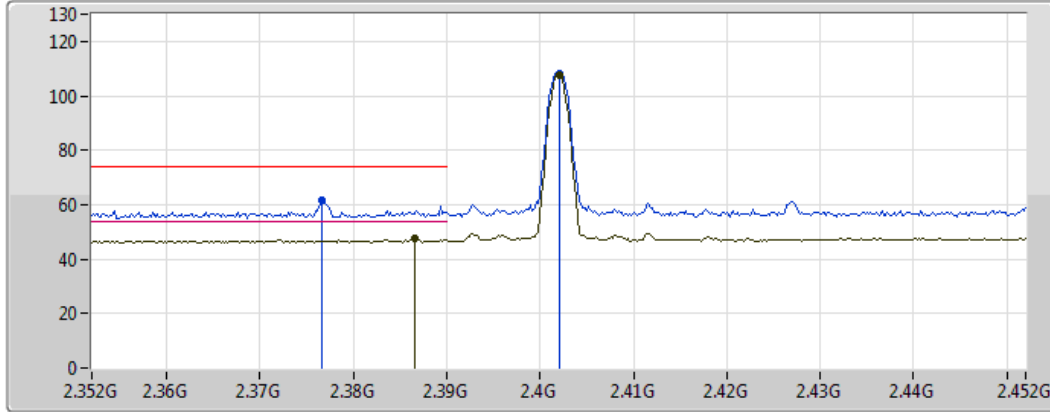
11/03/2018



Legend for the spectrum plot:

- Lim.PK 
- PK 
- Lim.AV 
- AV 

| Type | Freq (Hz) | Level (dBuV/m) | Limit (dBuV/m) | Margin (dB) | Factor (dB) | Dist (m) | Condition | Azimuth (°) | Height (m) | Comments | Raw (dBuV) | AF (dB) | CL (dB) | PA (dB) |
|------|-----------|----------------|----------------|-------------|-------------|----------|-----------|-------------|------------|----------|------------|---------|---------|---------|
| AV | 2.3866G | 47.87 | 54.00 | -6.13 | 30.45 | 3 | Vertical | 84 | 2.56 | - | 17.42 | 27.21 | 3.24 | - |
| AV | 2.402G | 107.73 | Inf | -Inf | 30.50 | 3 | Vertical | 84 | 2.56 | - | 77.23 | 27.25 | 3.25 | - |
| PK | 2.3766G | 61.72 | 74.00 | -12.28 | 30.41 | 3 | Vertical | 84 | 2.56 | - | 31.31 | 27.18 | 3.23 | - |
| PK | 2.402G | 108.13 | Inf | -Inf | 30.50 | 3 | Vertical | 84 | 2.56 | - | 77.63 | 27.25 | 3.25 | - |



BT-LE(1Mbps)

2402MHz_TX

11/03/2018

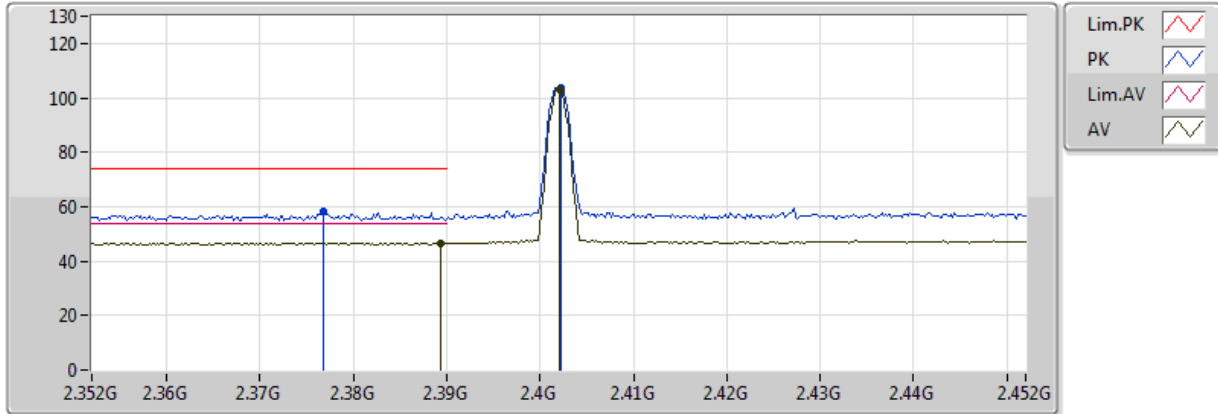

| Type | Freq (Hz) | Level (dBuV/m) | Limit (dBuV/m) | Margin (dB) | Factor (dB) | Dist (m) | Condition | Azimuth (°) | Height (m) | Comments | Raw (dBuV) | AF (dB) | CL (dB) | PA (dB) |
|------|-----------|----------------|----------------|-------------|-------------|----------|------------|-------------|------------|----------|------------|---------|---------|---------|
| AV | 2.3894G | 46.73 | 54.00 | -7.27 | 30.45 | 3 | Horizontal | 102 | 1.44 | - | 16.28 | 27.21 | 3.24 | - |
| AV | 2.402G | 103.17 | Inf | -Inf | 30.50 | 3 | Horizontal | 102 | 1.44 | - | 72.67 | 27.25 | 3.25 | - |
| PK | 2.3768G | 58.53 | 74.00 | -15.47 | 30.41 | 3 | Horizontal | 102 | 1.44 | - | 28.12 | 27.18 | 3.23 | - |
| PK | 2.4022G | 103.61 | Inf | -Inf | 30.50 | 3 | Horizontal | 102 | 1.44 | - | 73.11 | 27.25 | 3.25 | - |



BT-LE(1Mbps)

2402MHz_TX

11/03/2018

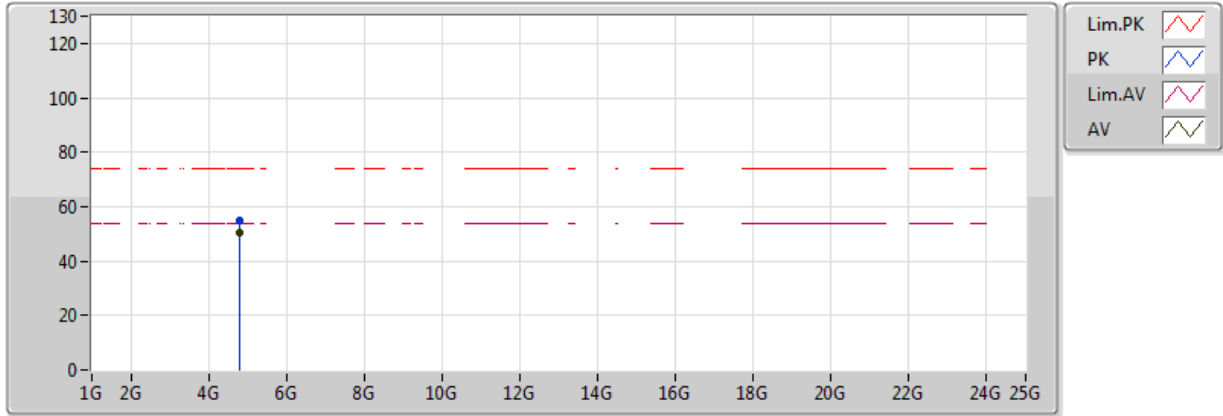

| Type | Freq (Hz) | Level (dBuV/m) | Limit (dBuV/m) | Margin (dB) | Factor (dB) | Dist (m) | Condition | Azimuth (°) | Height (m) | Comments | Raw (dBuV) | AF (dB) | CL (dB) | PA (dB) |
|------|-----------|----------------|----------------|-------------|-------------|----------|-----------|-------------|------------|----------|------------|---------|---------|---------|
| AV | 4.80394G | 50.16 | 54.00 | -3.84 | 5.85 | 3 | Vertical | 184 | 1.75 | - | 44.31 | 31.19 | 4.51 | 29.85 |
| PK | 4.80356G | 54.83 | 74.00 | -19.17 | 5.85 | 3 | Vertical | 184 | 1.75 | - | 48.98 | 31.19 | 4.51 | 29.85 |



BT-LE(1Mbps)

2402MHz_TX

11/03/2018

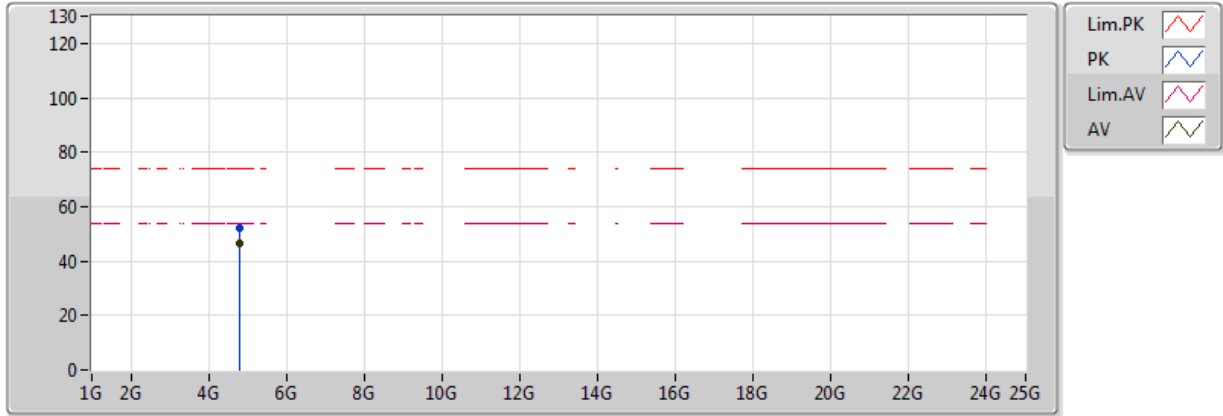

| Type | Freq (Hz) | Level (dBuV/m) | Limit (dBuV/m) | Margin (dB) | Factor (dB) | Dist (m) | Condition | Azimuth (°) | Height (m) | Comments | Raw (dBuV) | AF (dB) | CL (dB) | PA (dB) |
|------|-----------|----------------|----------------|-------------|-------------|----------|------------|-------------|------------|----------|------------|---------|---------|---------|
| AV | 4.80402G | 46.45 | 54.00 | -7.55 | 5.85 | 3 | Horizontal | 205 | 1.51 | - | 40.60 | 31.19 | 4.51 | 29.85 |
| PK | 4.80438G | 51.94 | 74.00 | -22.06 | 5.85 | 3 | Horizontal | 205 | 1.51 | - | 46.09 | 31.19 | 4.51 | 29.85 |

BT-LE(1Mbps)

2440MHz_TX

11/03/2018

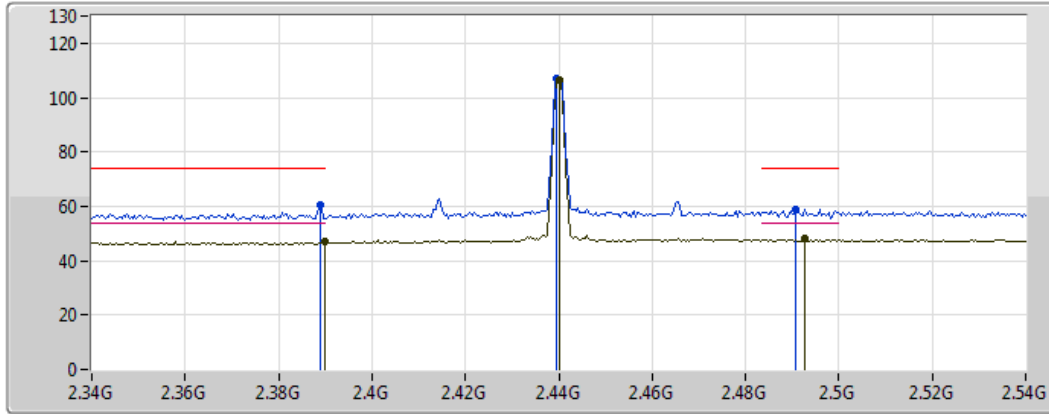

Legend for the spectrum plot:

- Lim.PK (Red line)
- PK (Blue line)
- Lim.AV (Pink line)
- AV (Black line)

| Type | Freq (Hz) | Level (dBuV/m) | Limit (dBuV/m) | Margin (dB) | Factor (dB) | Dist (m) | Condition | Azimuth (°) | Height (m) | Comments | Raw (dBuV) | AF (dB) | CL (dB) | PA (dB) |
|------|-----------|----------------|----------------|-------------|-------------|----------|-----------|-------------|------------|----------|------------|---------|---------|---------|
| AV | 2.389998G | 46.99 | 54.00 | -7.01 | 30.45 | 3 | Vertical | 81 | 2.62 | - | 16.54 | 27.21 | 3.24 | - |
| AV | 2.44G | 106.54 | Inf | -Inf | 30.63 | 3 | Vertical | 81 | 2.62 | - | 75.91 | 27.34 | 3.29 | - |
| AV | 2.4928G | 48.00 | 54.00 | -6.00 | 30.82 | 3 | Vertical | 81 | 2.62 | - | 17.18 | 27.48 | 3.34 | - |
| PK | 2.3888G | 60.63 | 74.00 | -13.37 | 30.45 | 3 | Vertical | 81 | 2.62 | - | 30.18 | 27.21 | 3.24 | - |
| PK | 2.4396G | 107.00 | Inf | -Inf | 30.63 | 3 | Vertical | 81 | 2.62 | - | 76.37 | 27.34 | 3.29 | - |
| PK | 2.4908G | 58.74 | 74.00 | -15.26 | 30.82 | 3 | Vertical | 81 | 2.62 | - | 27.92 | 27.48 | 3.34 | - |

BT-LE(1Mbps)

2440MHz_TX

11/03/2018

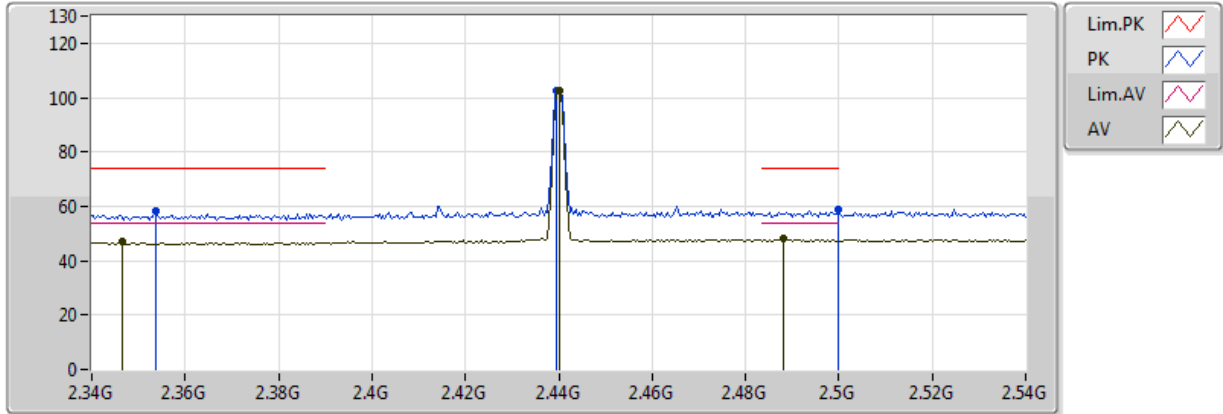

| Type | Freq (Hz) | Level (dBuV/m) | Limit (dBuV/m) | Margin (dB) | Factor (dB) | Dist (m) | Condition | Azimuth (°) | Height (m) | Comments | Raw (dBuV) | AF (dB) | CL (dB) | PA (dB) |
|------|-----------|----------------|----------------|-------------|-------------|----------|------------|-------------|------------|----------|------------|---------|---------|---------|
| AV | 2.3464G | 46.94 | 54.00 | -7.06 | 30.30 | 3 | Horizontal | 96 | 1.07 | - | 16.64 | 27.10 | 3.20 | - |
| AV | 2.44G | 102.32 | Inf | -Inf | 30.63 | 3 | Horizontal | 96 | 1.07 | - | 71.69 | 27.34 | 3.29 | - |
| AV | 2.488G | 48.00 | 54.00 | -6.00 | 30.81 | 3 | Horizontal | 96 | 1.07 | - | 17.19 | 27.47 | 3.34 | - |
| PK | 2.3536G | 58.16 | 74.00 | -15.84 | 30.33 | 3 | Horizontal | 96 | 1.07 | - | 27.83 | 27.12 | 3.21 | - |
| PK | 2.4396G | 102.77 | Inf | -Inf | 30.63 | 3 | Horizontal | 96 | 1.07 | - | 72.14 | 27.34 | 3.29 | - |
| PK | 2.499998G | 58.76 | 74.00 | -15.24 | 30.85 | 3 | Horizontal | 96 | 1.07 | - | 27.91 | 27.50 | 3.35 | - |



BT-LE(1Mbps)

2440MHz_TX

11/03/2018

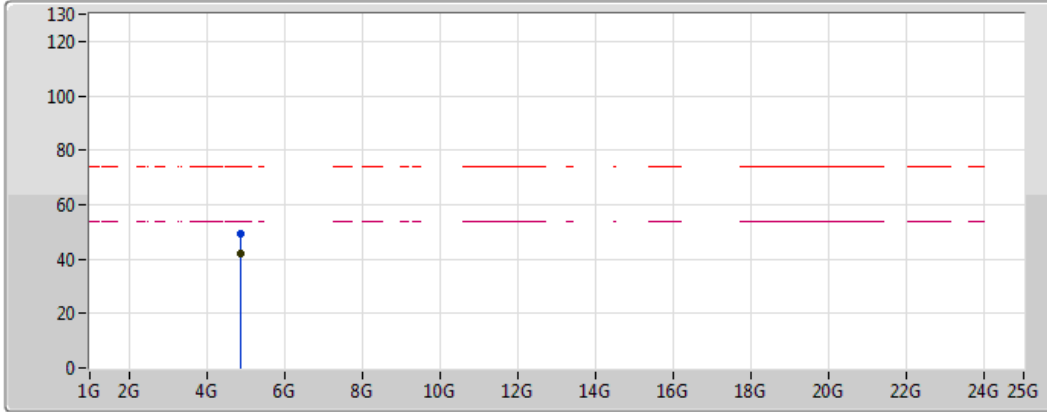

| Type | Freq (Hz) | Level (dBuV/m) | Limit (dBuV/m) | Margin (dB) | Factor (dB) | Dist (m) | Condition | Azimuth (°) | Height (m) | Comments | Raw (dBuV) | AF (dB) | CL (dB) | PA (dB) |
|------|--------------|-------------------|-------------------|----------------|----------------|-------------|-----------|----------------|---------------|----------|---------------|------------|------------|------------|
| AV | 4.87998G | 41.91 | 54.00 | -12.09 | 6.02 | 3 | Vertical | 182 | 1.99 | - | 35.89 | 31.31 | 4.55 | 29.83 |
| PK | 4.87972G | 49.10 | 74.00 | -24.90 | 6.02 | 3 | Vertical | 182 | 1.99 | - | 43.08 | 31.31 | 4.55 | 29.83 |



BT-LE(1Mbps)

2440MHz_TX

11/03/2018

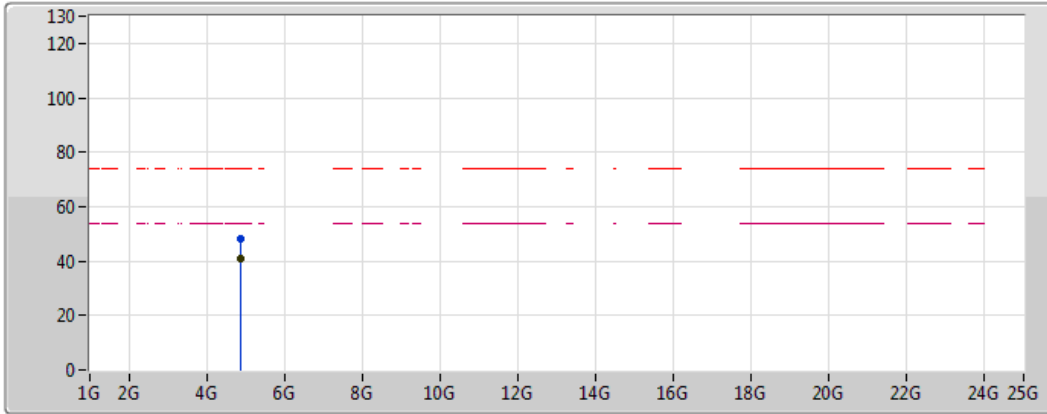

Legend for plot:

- Lim.PK: Red dashed line
- PK: Blue line with peak marker
- Lim.AV: Magenta dashed line
- AV: Magenta line with average marker

| Type | Freq (Hz) | Level (dBuV/m) | Limit (dBuV/m) | Margin (dB) | Factor (dB) | Dist (m) | Condition | Azimuth (°) | Height (m) | Comments | Raw (dBuV) | AF (dB) | CL (dB) | PA (dB) |
|------|-----------|----------------|----------------|-------------|-------------|----------|------------|-------------|------------|----------|------------|---------|---------|---------|
| AV | 4.88004G | 40.86 | 54.00 | -13.14 | 6.02 | 3 | Horizontal | 206 | 1.13 | - | 34.84 | 31.31 | 4.55 | 29.83 |
| PK | 4.8805G | 48.39 | 74.00 | -25.61 | 6.03 | 3 | Horizontal | 206 | 1.13 | - | 42.36 | 31.31 | 4.55 | 29.83 |

BT-LE(1Mbps)

2480MHz_TX

11/03/2018

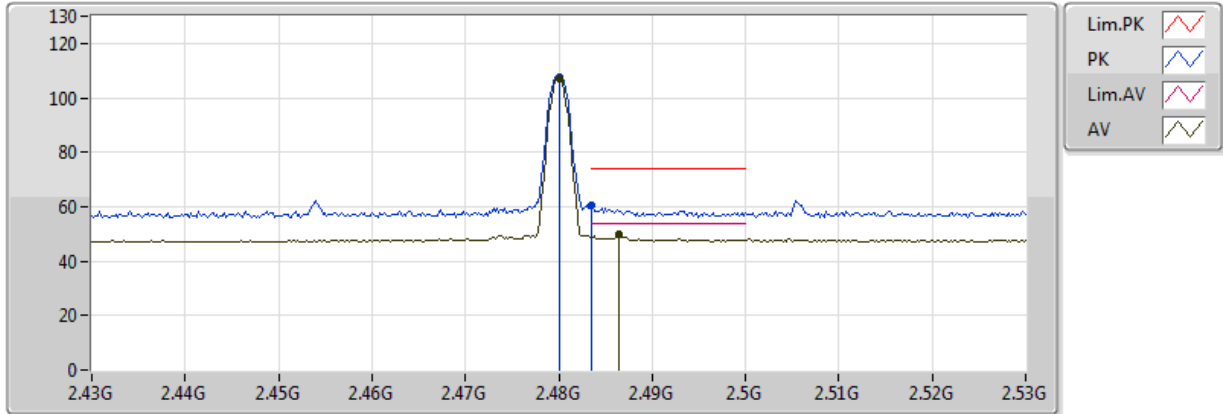

| Type | Freq (Hz) | Level (dBuV/m) | Limit (dBuV/m) | Margin (dB) | Factor (dB) | Dist (m) | Condition | Azimuth (°) | Height (m) | Comments | Raw (dBuV) | AF (dB) | CL (dB) | PA (dB) |
|------|-----------|----------------|----------------|-------------|-------------|----------|-----------|-------------|------------|----------|------------|---------|---------|---------|
| AV | 2.48G | 107.12 | Inf | -Inf | 30.78 | 3 | Vertical | 82 | 2.37 | - | 76.34 | 27.45 | 3.33 | - |
| AV | 2.4864G | 49.93 | 54.00 | -4.07 | 30.80 | 3 | Vertical | 82 | 2.37 | - | 19.13 | 27.46 | 3.34 | - |
| PK | 2.48G | 107.56 | Inf | -Inf | 30.78 | 3 | Vertical | 82 | 2.37 | - | 76.78 | 27.45 | 3.33 | - |
| PK | 2.483502G | 60.52 | 74.00 | -13.48 | 30.79 | 3 | Vertical | 82 | 2.37 | - | 29.73 | 27.46 | 3.33 | - |



BT-LE(1Mbps)

2480MHz_TX

11/03/2018

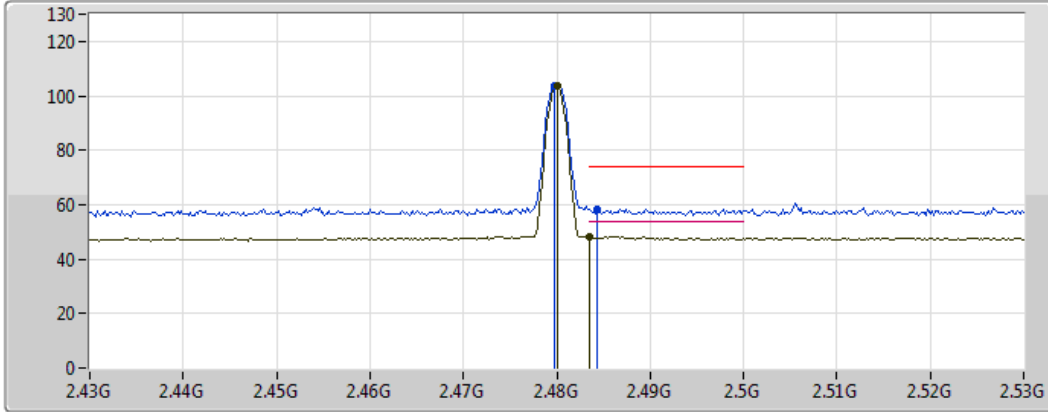

| Type | Freq (Hz) | Level (dBuV/m) | Limit (dBuV/m) | Margin (dB) | Factor (dB) | Dist (m) | Condition | Azimuth (°) | Height (m) | Comments | Raw (dBuV) | AF (dB) | CL (dB) | PA (dB) |
|------|-----------|----------------|----------------|-------------|-------------|----------|------------|-------------|------------|----------|------------|---------|---------|---------|
| AV | 2.48G | 103.40 | Inf | -Inf | 30.78 | 3 | Horizontal | 95 | 1.07 | - | 72.62 | 27.45 | 3.33 | - |
| AV | 2.483502G | 48.45 | 54.00 | -5.55 | 30.79 | 3 | Horizontal | 95 | 1.07 | - | 17.66 | 27.46 | 3.33 | - |
| PK | 2.4798G | 103.83 | Inf | -Inf | 30.78 | 3 | Horizontal | 95 | 1.07 | - | 73.05 | 27.45 | 3.33 | - |
| PK | 2.4844G | 58.51 | 74.00 | -15.49 | 30.79 | 3 | Horizontal | 95 | 1.07 | - | 27.72 | 27.46 | 3.33 | - |



BT-LE(1Mbps)

2480MHz_TX

11/03/2018

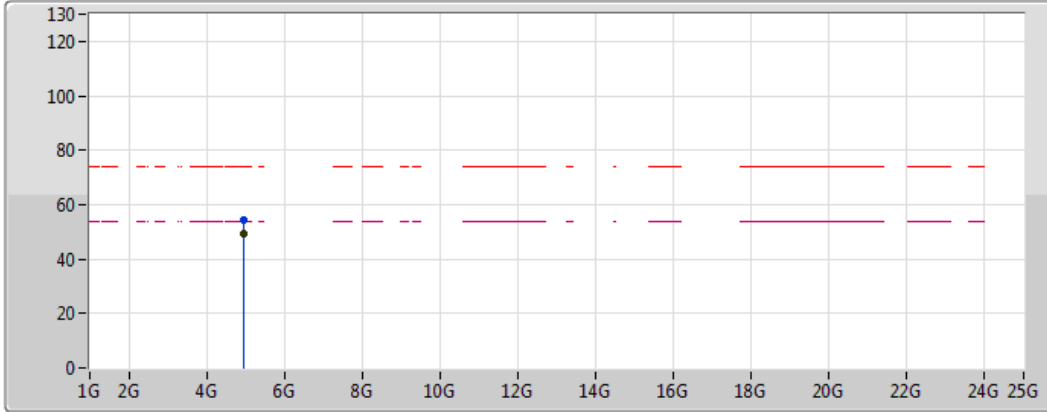

Legend for the spectrum plot:

- Lim.PK: Red dashed line
- PK: Blue solid line
- Lim.AV: Magenta dashed line
- AV: Black dashed line

| Type | Freq (Hz) | Level (dBuV/m) | Limit (dBuV/m) | Margin (dB) | Factor (dB) | Dist (m) | Condition | Azimuth (°) | Height (m) | Comments | Raw (dBuV) | AF (dB) | CL (dB) | PA (dB) |
|------|-----------|----------------|----------------|-------------|-------------|----------|-----------|-------------|------------|----------|------------|---------|---------|---------|
| AV | 4.95986G | 49.04 | 54.00 | -4.96 | 6.21 | 3 | Vertical | 153 | 1.89 | - | 42.83 | 31.44 | 4.59 | 29.82 |
| PK | 4.96048G | 54.19 | 74.00 | -19.81 | 6.21 | 3 | Vertical | 153 | 1.89 | - | 47.98 | 31.44 | 4.59 | 29.82 |

BT-LE(1Mbps)

2480MHz_TX

11/03/2018

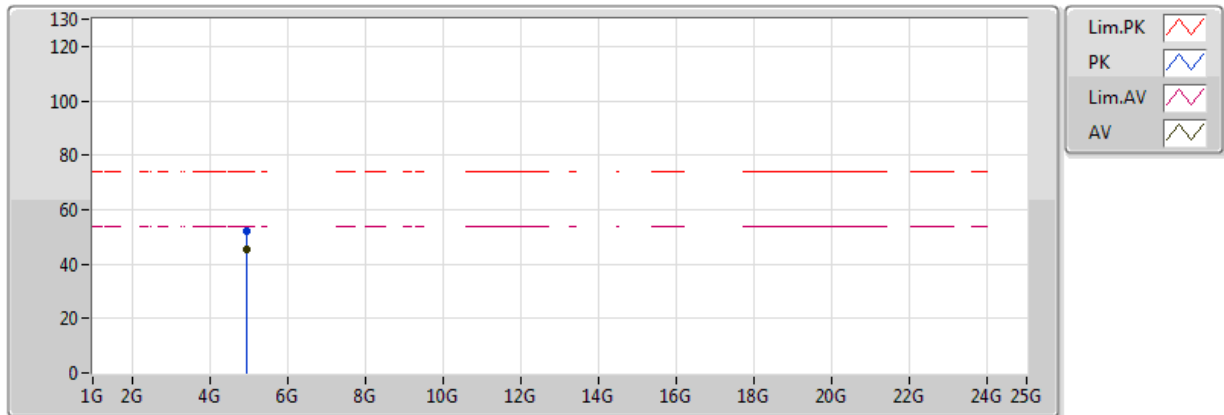

| Type | Freq (Hz) | Level (dBuV/m) | Limit (dBuV/m) | Margin (dB) | Factor (dB) | Dist (m) | Condition | Azimuth (°) | Height (m) | Comments | Raw (dBuV) | AF (dB) | CL (dB) | PA (dB) |
|------|-----------|----------------|----------------|-------------|-------------|----------|------------|-------------|------------|----------|------------|---------|---------|---------|
| AV | 4.95976G | 45.20 | 54.00 | -8.80 | 6.21 | 3 | Horizontal | 206 | 1.08 | - | 38.99 | 31.44 | 4.59 | 29.82 |
| PK | 4.95956G | 51.96 | 74.00 | -22.04 | 6.21 | 3 | Horizontal | 206 | 1.08 | - | 45.75 | 31.44 | 4.59 | 29.82 |