

LEDs



GPIO	I/O PORT Address : <Read/Write> #0EE0H Bit 0 : 0(Off) 1(On).
COMM	WLAN/HSDPA Status

SIM Card Socket

VTC 6110 can be internally integrated with a 3.5G Mini Card module. The SIM card bracket is on the carrier board. When using the GPRS/UMTS/HSDPA function, insert the SIM card into the SIM card socket. Make sure to turn off VTC 6110 before inserting the SIM card.

USB Port

The USB port complies with USB 2.0 specifications.

WiFi/Bluetooth Module Antenna Mounting Holes

The 3 external antenna mounting holes are used to mount and connect WiFi antenna to a WLAN module (Mini Card type).

GPRS/UMTS/HSDPA Module Antenna Mounting Hole

The antenna mounting hole is used to mount and connect an antenna to the GPRS/UMTS/HSDPA module.

Reset Button

Press this button to restart VTC 6110.

Line-out

Line-out is a stereo output for connecting external speakers.

Mic-in

Mic-in receives monophonic input from an external microphone.

Rear Panel

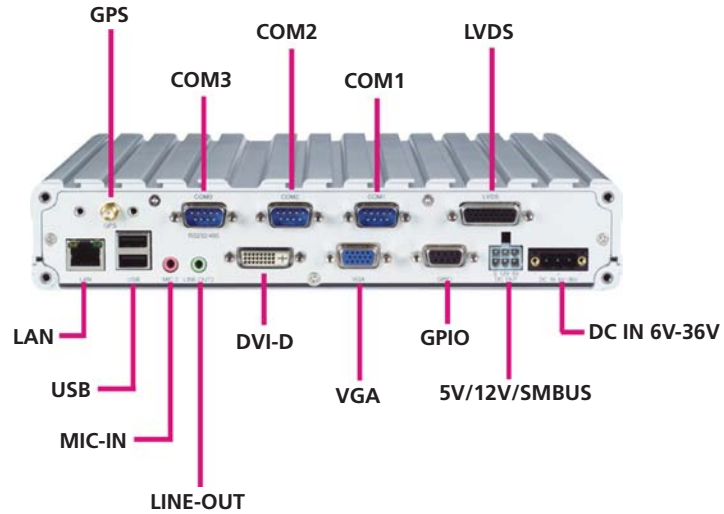

Power Input

DC Power Input Connector
Connector location

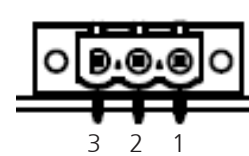

Connector pin definition (CN1)

Pin No.	Function Description
1	GND
2	VIN(6V~36V)
3	IGNITION

** Use power cable (+) with fuse for system protection

RS232/485 Connector COM3

The 9 pin D-Sub COM 3 port can be configured as RS232 or RS485 using the SW6 dip switch.

Connector size: DSUB-9 PIN

Connector location

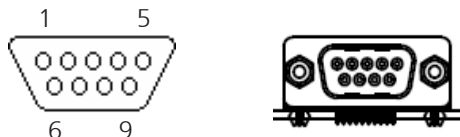

Connector pin definition

Pin	Definition	Pin	Definition
1	DCD (RS232) TX-/RX- (RS485)	2	RXD (RS232) TX+/RX+ (RS485)
3	TXD (RS232)	4	DTR (RS232)
5	GND	6	DSR (RS232)
7	RTS (RS232)	8	CTS (RS232)
9	RI (RS232)		

RS232 Connector COM1 and COM2

Connector size: DSUB-9 PIN

Connector location



Connector pin definition

Pin	Definition	Pin	Definition
1	DCD	2	RXD
3	TXD	4	DTR
5	GND	6	DSR
7	RTS	8	CTS
9	RI		

LVDS

Connector size: DB-26 PIN

Connector location

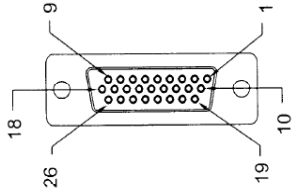

Connector pin definition

Pin	Definition	Pin	Definition
1	Panel_EN	2	Panel_control
3	VDD	4	VDD
5	LCDD09(OUT3)	6	LCDD01(OUT0)
7	LCDD08(OUT3#)	8	LCDD00(OUT0#)
9	LCDD_GND	10	LCDD_GND
11	LCDD07(CLK)	12	LCDD03(OUT1)
13	LCDD06(CLK#)	14	LCDD02(OUT1#)
15	LVDS_GND	16	LCDD_GND
17	LCDD05(OUT2)	18	Power on push button
19	LCDD04(OUT2#)	20	Panel_backlight
21	LCDD_GND	22	Panel-Gnd
23	USB_0#	24	Contact_DET#
25	USB_0	26	USB_VCC

External SMBus, 12V and 5V Power Output

Connector location

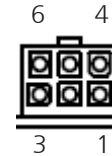

Connector pin definition

Pin	Definition	Pin	Definition
1	5V	2	12V
3	SMBus Clock	4	GND
5	GND	6	SMBus Data

+5 VDC (1A) and +12VDC (1A) power output and SMBus (w/o VTK 33M-01 connection)

+5 VDC (0.5A) and +12VDC (0.5A) power output and SMBus (w/ VTK 33M-01 connection)

VGA Port

The DB15 VGA port supports resolutions up to 1600x1200 @ 85 Hz, 2048x1536 @ 60Hz.

USB Port x 2

The two USB ports are compliant with USB 2.0 specifications.

LAN Port

The LAN port is an RJ45 interface with integrated LEDs and supports 10/100/1000Mbps Ethernet data transfer rates.

Audio Jacks (MIC-IN and LINE-OUT)

- MIC-IN jack receives monophonic input from an external microphone.
- LINE-OUT jack is the stereo output for connecting external speakers.

Mechanical Dimensions

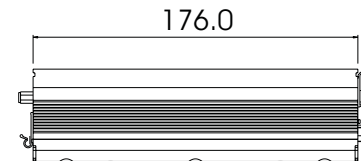
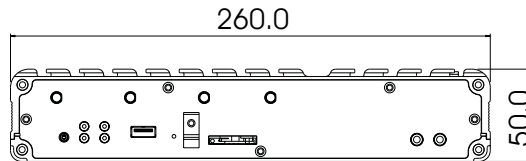
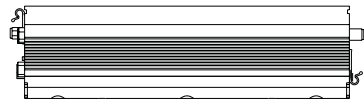
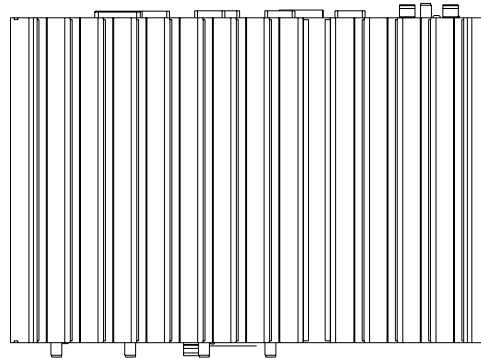
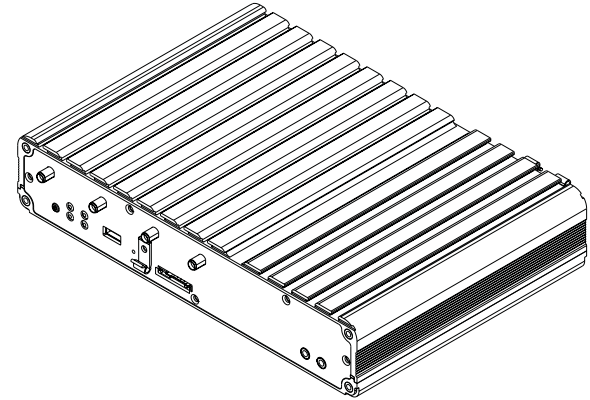
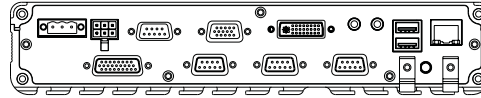

CHAPTER 2: JUMPERS AND CONNECTORS

This chapter describes how to set the jumpers on the motherboard. Note that the following procedures are generic for all VTC 6110 series.

Before You Begin

- Ensure you have a stable, clean working environment. Dust and dirt can get into components and cause a malfunction. Use containers to keep small components separated.
- Adequate lighting and proper tools can prevent you from accidentally damaging the internal components. Most of the procedures that follow require only a few simple tools, including the following:
 - A Philips screwdriver
 - A flat-tipped screwdriver
 - A set of jewelers Screwdrivers
 - A grounding strap
 - An anti-static pad
- Using your fingers can disconnect most of the connections. It is recommended that you do not use needle-nosed pliers to disconnect connections as these can damage the soft metal or plastic parts of the connectors.
- Before working on internal components, make sure that the power is off. Ground yourself before touching any internal components, by touching a metal object. Static electricity can damage many of the elec-

tronic components. Humid environment tend to have less static electricity than dry environments. A grounding strap is warranted whenever danger of static electricity exists.

Precautions

Computer components and electronic circuit boards can be damaged by discharges of static electricity. Working on the computers that are still connected to a power supply can be extremely dangerous.

Follow the guidelines below to avoid damage to your computer or yourself:

- Always disconnect the unit from the power outlet whenever you are working inside the case.
- If possible, wear a grounded wrist strap when you are working inside the computer case. Alternatively, discharge any static electricity by touching the bare metal chassis of the unit case, or the bare metal body of any other grounded appliance.
- Hold electronic circuit boards by the edges only. Do not touch the components on the board unless it is necessary to do so. Don't flex or stress the circuit board.
- Leave all components inside the static-proof packaging that they shipped with until they are ready for installation.
- Use correct screws and do not over tighten screws.

Jumper

A jumper is the simplest kind of electric switch. It consists of two metal pins and a cap. When setting the jumpers, ensure that the jumper caps are placed on the correct pins. When the jumper cap is placed on both pins, the jumper is **short**. If you remove the jumper cap, or place the jumper cap on just one pin, the jumper is **open**.

Refer to the illustrations below for examples of what the 2-pin and 3-pin jumpers look like when they are short (on) and open (off).

Two-Pin Jumpers: Open (Left) and Short (Right)

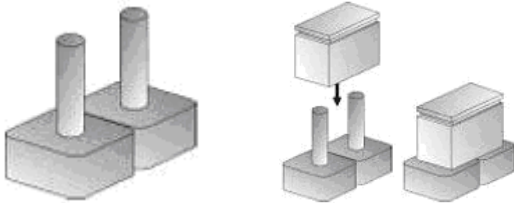

Three-Pin Jumpers: Pins 1 and 2 Are Short

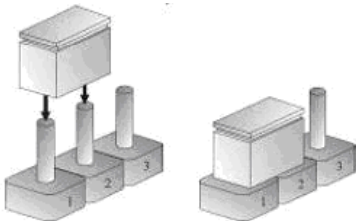

Jumper Settings

SW5: Input Voltage Selection

SW5 / Input Voltage	12V (default)	24V	6V~36V
SW5.1	OFF	OFF	ON
SW5.2	OFF	ON	Ignore

SW6: COM Port Mode Selection

SW6 COM Port Mode	RS232 (default)	RS485
SW6.1	OFF	ON
SW6.2	OFF	ON
SW6.3	OFF	ON

CF (IDE0) Primary Master/Slave Select (JP4)

Pin	Status	Function Description
1-2	Short	Slave
2-3 (default)	Short (default)	Master

LVDS Power Input Voltage Select (JP9)

Pin	Status	Function Description
1-2	Short	+5V IN
2-3 (default)	Short (default)	+3.3V IN

CMOS Input Voltage Select (J6)

Pin	Status	Function Description
1-2 (default)	Short (default)	VBAT IN
2-3	Short	Clear CMOS

BIOS Function Select (J1)

Pin	Status	Function Description
1-2	Short	Disable carrier board BIOS
2-3 (default)	Short (default)	Disable module board BIOS

DC Input Voltage Select (JP1)

Pin	Status	Function Description
1-2 (default)	Short (default)	IGNITION
2-3	Short	VIN_M

Temp Sensor (JP8)

Pin	Function Description
1	SENSOR+
2	GND

Auto Power Select (JP2)

Pin	Status	Function Description
1-2 (default)	Short (default)	AUTO
2-3	Short	BUTTON CONTROL

PCI-104 VI/O Select Voltage (J13)

Pin	Status	Function Description
1-4(*)	Short*	+3.3V
3-6	Short	+5V

MCU Download (JP6)

Pin	Function Description
1	+V3.3ALW
2	C2D
3	MRST
4	C2CK
5	GND

GAL Download (JP5)

Pin	Function Description
1	+V3.3S
2	GND
3	TCK
4	TDO
5	TDI
6	TMS

MCU COM Port (JP3)

Pin	Function Description
1	TX
2	RX
3	GND

Connectors

High Speed Board-to-Board Connector: COM Express Row A and Row B

Connector size: 2 x 110 = 220 pins

Connector location: J4



Connector Pin Definition

Row A		Row B		Row A		Row B	
A1	GND	B1	GND	A56	NC	B56	NC
A2	GBE0_MDI3-	B2	GBE0_ACT#	A57	GND	B57	NC
A3	GBE0_MDI3+	B3	LPC_FRAME#	A58	NC	B58	NC
A4	NC	B4	LPC_AD0	A59	NC	B59	NC
A5	NC	B5	LPC_AD1	A60	GND	B60	GND
A6	GBE0_MDI2-	B6	LPC_AD2	A61	NC	B61	NC
A7	GBE0_MDI2+	B7	LPC_AD3	A62	NC	B62	NC
A8	GBE0_LINK#	B8	NC	A63	GPI1	B63	GPO3
A9	GBE0_MDI1-	B9	NC	A64	NC	B64	NC
A10	GBE0_MDI1+	B10	LPC_CLK	A65	NC	B65	NC
A11	GND	B11	GND	A66	GND	B66	NC
A12	GBE0_MDI0-	B12	PWRBTN#	A67	NC	B67	NC

Row A		Row B		Row A		Row B	
A13	GBE0_MDI0+	B13	SMB_CK	A68	PCIE_TX0+	B68	PCIE_RX0+
A14	GBE0_CTREF	B14	SMB_DAT	A69	PCIE_TX0-	B69	PCIE_RX0-
A15	SUS_S3#	B15	SMB_ALERT#	A70	GND	B70	GND
A16	SATA0_TX+	B16	NC	A71	LVDS_A0+	B71	NC
A17	SATA0_TX-	B17	NC	A72	LVDS_A0-	B72	NC
A18	SUS_S4#	B18	SUS_STAT#	A73	LVDS_A1+	B73	NC
A19	SATA0_RX+	B19	NC	A74	LVDS_A1+	B74	NC
A20	SATA0_RX-	B20	NC	A75	LVDS_A2+	B75	NC
A21	GND	B21	GND	A76	LVDS_A2+	B76	NC
A22	NC	B22	NC	A77	LVDS_VDD_EN	B77	NC
A23	NC	B23	NC	A78	LVDS_A3+	B78	NC
A24	SUS_S5#	B24	PWR_OK	A79	LVDS_A3+	B79	LVDS_BKLT_EN
A25	NC	B25	NC	A80	GND	B80	GND
A26	NC	B26	NC	A81	LVDS_A_CK+	B81	NC
A27	BATLOW#	B27	NC	A82	LVDS_A_CK-	B82	NC
A28	ATA_ACT#	B28	NC	A83	LVDS_I2C_CK	B83	LVDS_BKLT_CTRL
A29	AC_SYNC	B29	NC	A84	LVDS_I2C_DAT	B84	VCC_5V_SBY
A30	AC_RST#	B30	AC_SDINO	A85	NC	B85	VCC_5V_SBY
A31	GND	B31	GND	A86	NC	B86	VCC_5V_SBY
A32	AC_BITCLK	B32	SPKR	A87	NC	B87	VCC_5V_SBY
A33	AC_SDOOUT	B33	I2C_CK	A88	PCIE0_CK_REF+	B88	RSVD
A34	NC	B34	I2C_DAT	A89	PCIE0_CK_REF-	B89	NC
A35	NC	B35	THRM#	A90	GND	B90	GND
A36	USB6-	B36	NC	A91	RSVD	B91	NC
A37	USB6+	B37	NC	A92	RSVD	B92	NC
A38	USB_6_7_OC#	B38	USB_4_5_OC#	A93	NC	B93	NC
A39	USB4-	B39	USB5-	A94	RSVD	B94	NC

Row A		Row B		Row A		Row B	
A40	USB4+	B40	USB5+	A95	RSVD	B95	NC
A41	GND	B41	GND	A96	GND	B96	NC
A42	USB2-	B42	USB3-	A97	VCC_12V	B97	NC
A43	USB2+	B43	USB3+	A98	VCC_12V	B98	NC
A44	USB_2_3_OC#	B44	USB_0_1_OC#	A99	VCC_12V	B99	NC
A45	USB0-	B45	USB1-	A100	GND	B100	GND
A46	USB0+	B46	USB1+	A101	VCC_12V	B101	VCC_12V
A47	VCC_RTC	B47	NC	A102	VCC_12V	B102	VCC_12V
A48	NC	B48	NC	A103	VCC_12V	B103	VCC_12V
A49	NC	B49	SYS_RESET#	A104	VCC_12V	B104	VCC_12V
A50	NC	B50	CB_RESET#	A105	VCC_12V	B105	VCC_12V
A51	GND	B51	GND	A106	VCC_12V	B106	VCC_12V
A52	NC	B52	NC	A107	VCC_12V	B107	VCC_12V
A53	NC	B53	NC	A108	VCC_12V	B108	VCC_12V
A54	NC	B54	NC	A109	VCC_12V	B109	VCC_12V
A55	NC	B55	NC	A110	GND	B110	GND

High Speed Board-to-Board Connector: COM Express Row C and Row D

Connector size: 2 X 110 = 220 Pins

Connector location: J3



Connector Pin Definition

Row C		Row D		Row C		Row D	
C1	GND	D1	GND	C56	NC	D56	SDVOB_GREEN-
C2	IDE_D7	D2	IDE_D5	C57	NC	D57	NC
C3	IDE_D6	D3	IDE_D10	C58	NC	D58	SDVOB_BLUE+
C4	IDE_D3	D4	IDE_D11	C59	NC	D59	SDVOB_BLUE-
C5	IDE_D15	D5	IDE_D12	C60	GND	D60	GND
C6	IDE_D8	D6	IDE_D4	C61	NC	D61	SDVO_CLK+
C7	IDE_D9	D7	IDE_D0	C62	NC	D62	SDVO_CLK-
C8	IDE_D2	D8	IDE_REQ	C63	NC	D63	NC
C9	IDE_D13	D9	IDE_IOW#	C64	NC	D64	NC
C10	IDE_D1	D10	IDE_ACK#	C65	NC	D65	NC
C11	GND	D11	GND	C66	NC	D66	NC
C12	IDE_D14	D12	IDE_IRQ	C67	NC	D67	GND

Row C		Row D		Row C		Row D	
C13	IDE_IORDY	D13	IDE_A0	C68	NC	D68	NC
C14	IDE_IOR#	D14	IDE_A1	C69	NC	D69	NC
C15	NC	D15	IDE_A2	C70	GND	D70	GND
C16	NC	D16	IDE_CS1#	C71	NC	D71	NC
C17	NC	D17	IDE_CS3#	C72	NC	D72	NC
C18	NC	D18	IDE_RESET#	C73	NC	D73	SDVO_CLK
C19	NC	D19	NC	C74	NC	D74	NC
C20	PCI_GNT0#	D20	NC	C75	NC	D75	NC
C21	GND	D21	GND	C76	GND	D76	GND
C22	PCI_REQ0#	D22	PCI_AD1	C77	NC	D77	IDE_CBLID#
C23	PCI_RESET#	D23	PCI_AD3	C78	NC	D78	NC
C24	PCI_AD0	D24	PCI_AD5	C79	NC	D79	NC
C25	PCI_AD2	D25	PCI_AD7	C80	GND	D80	GND
C26	PCI_AD4	D26	PCI_C/BE0#	C81	NC	D81	NC
C27	PCI_AD6	D27	PCI_AD9	C82	NC	D82	NC
C28	PCI_AD8	D28	PCI_AD11	C83	NC	D83	NC
C29	PCI_AD10	D29	PCI_AD13	C84	GND	D84	GND
C30	PCI_AD12	D30	PCI_AD15	C85	NC	D85	NC
C31	GND	D31	GND	C86	NC	D86	NC
C32	PCI_AD14	D32	PCI_PAR	C87	GND	D87	GND
C33	PCI_C/BE1#	D33	PCI_SERR#	C88	NC	D88	NC
C34	PCI_PERR#	D34	PCI_STOP#	C89	NC	D89	NC
C35	PCI_LOCK#	D35	PCI_TRDY#	C90	GND	D90	GND
C36	PCI_DEVSEL#	D36	PCI_FRAME#	C91	NC	D91	NC
C37	PCI_IRDY#	D37	PCI_AD16	C92	NC	D92	NC
C38	PCI_C/BE2#	D38	PCI_AD18	C93	GND	D93	GND
C39	PCI_AD17	D39	PCI_AD20	C94	NC	D94	NC

Row C		Row D		Row C		Row D	
C40	PCI_AD19	D40	PCI_AD22	C95	PEG_RX13-	D95	PEG_TX13-
C41	GND	D41	GND	C96	GND	D96	GND
C42	PCI_AD21	D42	PCI_AD24	C97	RSVD	D97	PEG_ENABLE#
C43	PCI_AD23	D43	PCI_AD26	C98	PEG_RX14+	D98	PEG_TX14+
C44	PCI_C/BE3#	D44	PCI_AD28	C99	PEG_RX14-	D99	PEG_TX14-
C45	PCI_AD25	D45	PCI_AD30	C100	GND	D100	GND
C46	PCI_AD27	D46	PCI_IRQC#	C101	PEG_RX15+	D101	PEG_TX15+
C47	PCI_AD29	D47	PCI_IRQD#	C102	PEG_RX15-	D102	PEG_TX15-
C48	PCI_AD31	D48	PCI_CLKRUN#	C103	GND	D103	GND
C49	PCI_IRQA#	D49	PCI_M66EN	C104	VCC_12V	D104	VCC_12V
C50	PCI_IRQB#	D50	PCI_CLK	C105	VCC_12V	D105	VCC_12V
C51	GND	D51	GND	C106	VCC_12V	D106	VCC_12V
C52	PEG_RX0+	D52	PEG_TX0+	C107	VCC_12V	D107	VCC_12V
C53	PEG_RX0-	D53	PEG_TX0-	C108	VCC_12V	D108	VCC_12V
C54	TYPE0#	D54	PEG_LANE_RV#	C109	VCC_12V	D109	VCC_12V
C55	PEG_RX1+	D55	PEG_TX1+	C110	GND	D110	GND

CompactFlash Connector

Connector size: 2 x 25 = 50 pins

Connector location: J12

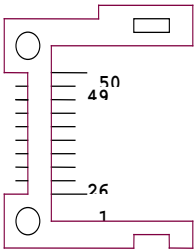

Connector Pin Definition

Pin	Description	Pin	Description
1	Gnd	2	Data 3
3	Data 4	4	Data 5
5	Data 6	6	Data 7
7	HDC CS100	8	Gnd
9	Gnd	10	Gnd
11	Gnd	12	Gnd
13	+5V	14	Gnd
15	Gnd	16	Gnd
17	Gnd	18	Disk Address 2
19	Disk Address 1	20	Disk Address 0
21	Data 0	22	Data 1

Pin	Description	Pin	Description
23	Data 2	24	IOCS16# (NC)
25	CF_CD2# (Pull-down)	26	CF_CD1# (Pull-down)
27	Data 11	28	Data 12
29	Data 13	30	Data 14
31	Data 15	32	HDC CS300
33	CF_VS1# (NC)	34	IOR
35	IOW	36	CF_WE# (+5V)
37	Interrupt 15	38	+5V
39	CF_CSEL# (Master or Slave)	40	CF_VS2# (NC)
41	Reset #	42	IOCHRDY
43	DMA REQ / DACK (NC)	44	DMA ACK# /CF_REG# (+5V)
45	HDD Active Led	46	DMA66 Detect / CF_PDIAG#
47	Data 8	48	Data 9
49	Data 10	50	Gnd

GPIO Connector

Connector size: DSUB-9 pin
 Connector location: COM1

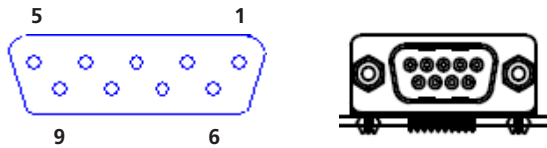

Connector Pin Definition

Pin	Description	Pin	Description
1	GIN1	2	GIN2
3	GIN3	4	GIN4
5	GOUT4	6	GOUT1
7	GOUT2	8	GOUT3
9	GND		

RS232 Connector: COM1, COM2

Connector size: 2 x 10 = 20 Pins Pin Header, (2.0 mm Pitch)
 Connector location: COM1 (CN9), COM2 (CN7)

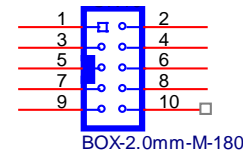

Connector Pin Definition

Pin	Definition	Pin	Definition
1	DCD	2	RXD
3	TXD	4	DTR
5	Gnd	6	DSR
7	RTS	8	CTS
9	RI		

RS232/485 Connector: COM3

Connector size: 2 x 10 = 20 Pins Pin Header, (2.0 mm Pitch)

Connector location: CN12

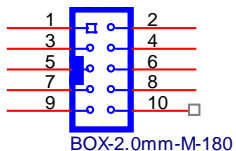

Connector Pin Definition

Pin	Definition	Pin	Definition
1	DCD (RS232) TX-/RX- (RS485)	2	RXD (RS232) TX+/RX+ (RS485)
3	TXD (RS232)	4	DTR (RS232)
5	Gnd	6	DSR (RS232)
7	RTS (RS232)	8	CTS (RS232)
9	RI (RS232)		

GAL Programmer PIN Header

Connector size: 2.54mm-M-180

Connector location: JP5

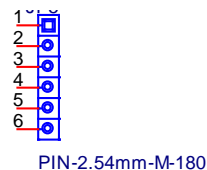

Connector Pin Definition

Pin	Definition	Pin	Definition
1	+3.3V	2	GND
3	TCK	4	TDO
5	TDI	6	TMS

MCU Programmer Pin Header

Connector size: 2.54mm-M-180

Connector location: JP6

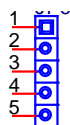

PIN-2.54mm-M-180

Connector Pin Definition

Pin	Definition	Pin	Definition
1	+3.3ALW	2	C2D
3	MRST	4	C2CK
5	GND		

VGA Connector

Connector size: DSUB-15

Connector location: CON1

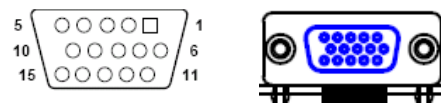

Connector Pin Definition

Pin	Definition	Pin	Definition
1	RED	2	GREEN
3	BLUE	4	NC
5	Gnd	6	Gnd
7	Gnd	8	Gnd
9	VCC	10	Gnd
11	NC	12	DDCDAT
13	Hsync	14	Vsync
15	DDCCLK		

LVDS Connector + USB0

Connector size: 2 x 15 (2.0mm)

Connector location: CN3

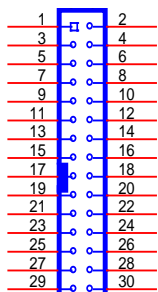

BOX-2.0mm-M-180

Pin	Definition	Pin	Definition
17	LVDS_5(OUT2)	18	Panel_backlight(+12V)
19	LVDS_4(OUT2#)	20	Panel_backlight(+12V)
21	LVDS_GND	22	Power on push button
23	USB_0#	24	Contact_DET#
25	USB_0	26	USB_VCC (+5V)
27	USB_GND	28	USB_GND
29	Panel_backlight(+12V)	30	GND

Connector Pin Definition

Pin	Definition	Pin	Definition
1	LVDS_CLK	2	LVDS_DAT
3	Panel_VDD	4	LVDS_1(OUT0)
5	LVDS_9(OUT3)	6	LVDS_0(OUT0#)
7	LVDS_8(OUT3#)	8	Panel_VDD
9	LVDS_GND	10	LVDS_GND
11	LVDS_7(CLK)	12	LVDS_3(OUT1)
13	LVDS_6(CLK#)	14	LVDS_2(OUT1#)
15	LVDS_GND	16	LVDS_GND

LAN Connector

Connector size: RJ-45

Connector location: LAN1



Connector Pin Definition

Pin	Definition	Pin	Definition
1	TX+	2	TX-
3	RX+	4	N/C1
5	N/C2	6	RX-
7	N/C3	8	N/C4
9	LAN Speed LED	10	+3.3V
11	LAN Link LED	12	+3.3V

USB Connector

Connector location: USB1



Connector Pin Definition

Pin	Definition	Pin	Definition
1	VCC	2	DATA-
3	DATA+	4	GND

USB Connector

Connector location: USB2



Connector Pin Definition

Pin	Definition	Pin	Definition
1	VCC	2	DATA1-
3	DATA1+	4	GND
5	VCC	6	DATA-
7	DATA+	8	GND

LVDS Power Connector

Connector location: J5



Connector Pin Definition

Pin	Definition	Pin	Definition
1	Panel_backlight	2	Panel_VDD
3	GND	4	GND
5	LVDS_PANEL	6	LVDS_BIASON

External 12V & 5V Power and SMBUS Connector

Connector location: CN2

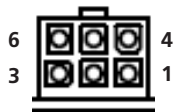

Connector Pin Definition

Pin	Definition	Pin	Definition
1	5V	2	12V
3	SMBCLK	4	GND
5	GND	6	SMBDATA

Mic-in

Connector location: CN11 and CN15



Connector Pin Definition

Pin	Definition	Pin	Definition
1	NC	2	MIC_JD
3	NC	4	MIC_OUT
5	GND	6	GND

Line-out

Connector location: CN8 and CN14



Connector Pin Definition

Pin	Definition	Pin	Definition
1	LINE_OUT_L	2	SURR_JD
3	NC	4	LINE_OUT_R
5	GND	6	GND

PCI-104 VI/O Voltage Setting

Connector location: J13

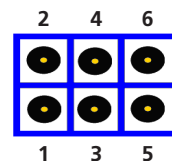

Connector Pin Definition

Pin No.	Status	Function Description
1-3, 2-4 (default)	Short	+3.3V
3-5, 4-6	Short	+5V

PCI-104 Connector

Connector location: CN16

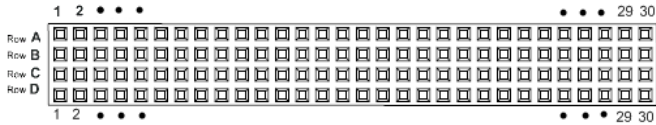

Connector Pin Definition

Pin	A	B	C	D
1	GND	Reserved	+5	AD00
2	VI/O	AD02	AD01	+5V
3	AD05	GND	AD04	AD03
4	C/BE0#	AD07	GND	AD06
5	GND	AD09	AD08	GND
6	AD11	VI/O	AD10	M66EN
7	AD14	AD13	GND	AD12
8	+3.3V	C/BE1#	AD15	+3.3V
9	SERR#	GND	Reserved	PAR
10	GND	PERR#	+3.3V	Reserved
11	STOP#	+3.3V	LOCK#	GND
12	+3.3V	TRDY#	GND	DEVSEL#
13	FRAME#	GND	IRDY#	+3.3V
14	GND	AD16	+3.3V	C/BE2#
15	AD18	+3.3V	AD17	GND
16	AD21	AD20	GND	AD19
17	+3.3V	AD23	AD22	+3.3V
18	IDSEL0	GND	IDSEL1	IDSEL2
19	AD24	C/BE3#	VI/O	IDSEL3
20	GND	AD26	AD25	GND
21	AD29	+5V	AD28	AD27
22	+5V	AD30	GND	AD31
23	REQ0#	GND	REQ1#	VI/O
24	GND	REQ2#	+5V	GNT0#
25	GNT1#	VI/O	GNT2#	GND
26	+5V	CLK0	GND	CLK1
27	CLK2	+5V	CLK3	GND
28	GND	INTD#	+5V	RST#
29	+12V	INTA#	INTB#	INTC#
30	-12V	REQ3#	GNT3#	GND

Power Button

Connector location: SW1

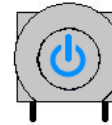

Reset Button

Connector location: SW2



MCU COM Port

Connector location: JP3

Connector Pin Definition

Pin	Function Description
1	TX
2	RX
3	GND

ACC_ON LED

Connector location: JP7



Connector Pin Definition

Pin	Function Description
1	+3.3V LED
2	GND

Temp Sensor

Connector location: JP8



Connector Pin Definition

Pin	Function Description
1	SENSOR+
2	GND

DC Power Input Connector

Connector location: CN1



Connector Pin Definition

Pin	Function Description
1	GND
2	VIN (6V~36V)
3	IGNITION

Power On and IDE Active LED

Connector location: LED1

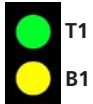

Connector Pin Definition

LED	Function Description
T1	POWER LED
B1	HD LED

GPIO and UMTS LEDs

Connector location: LED2

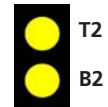

LED I/O Port Address and Data

LED	Function Description
T2	I/O PORT Address: 0EE0; Bit0: 1 (Light), 0 (Dark)
B2	UMTS STATUS

Serial ATA

Connector location: CN6



Connector Pin Definition

Pin	Definition	Pin	Definition
1	GND	2	SATA_TXP0 -
3	SATA_TXN0	4	GND
5	SATA_RXN0	6	SATA_RXP0
7	GND		

Serial ATA Power Input

Connector location: J10



Connector Pin Definition

Pin	Definition	Pin	Definition
1	+V12S	2	GND
3	GND	4	+V5S

Mini-PCle Socket (for 3.5G module)

PCIe Interface

Connector location: CN10

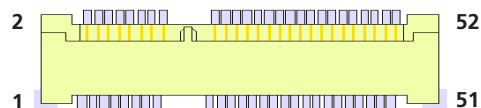

Connector Pin Definition

Pin	Definition	Pin	Definition	Pin	Definition	Pin	Definition
1	MIC +	2	+V3.3S	27	GND	28	NC
3	MIC -	4	GND	29	GND	30	NC
5	SPK +	6	NC	31	NC	32	NC
7	GND	8	USIM PWR	33	RESET	34	GND
9	GND	10	USIM DATA	35	GND	36	USB_D-
11	VCC_MSM26_DIG	12	USIM CLK	37	GND	38	USB_D+
13	NC	14	USIM RST	39	+V3.3S	40	GND
15	GND	16	NC	41	+V3.3S	42	LED_WWAN#
17	NC	18	GND	43	GND	44	NC
19	NC	20	W_DISABLE#	45	NC	46	NC
21	GND	22	NC	47	NC	48	NC
23	NC	24	NC	49	NC	50	GND
25	NC	26	GND	51	NC	52	+V3.3S

Mini-PCle Socket (for WLAN module)

USB + PCIe Interface

Connector location: CN13

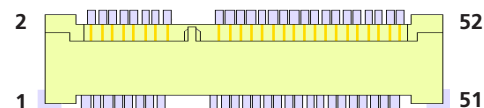

Connector Pin Definition

Pin	Definition	Pin	Definition	Pin	Definition	Pin	Definition
1	WAKE#	2	+V3.3S	27	GND	28	+V1.5S
3	NC	4	GND	29	GND	30	SMB_CLK
5	NC	6	+V1.5S	31	PETn0	32	SMB_DATA
7	CLKREQ#	8	NC	33	PETp0	34	GND
9	GND	10	NC	35	GND	36	USB_D-
11	REFCLK-	12	NC	37	NC	38	USB_D+
13	REFCLK+	14	NC	39	NC	40	GND
15	GND	16	NC	41	NC	42	LED_WWAN#
17	NC	18	GND	43	NC	44	LED_WLAN#
19	NC	20	DISABLE#	45	NC	46	LED_WPAN#
21	GND	22	PERST#	47	NC	48	+V1.5S
23	PERn0	24	+3.3S	49	NC	50	GND
25	PERp0	26	GND	51	NC	52	+V3.3S

SIM Card Connector

Connector location: CN4

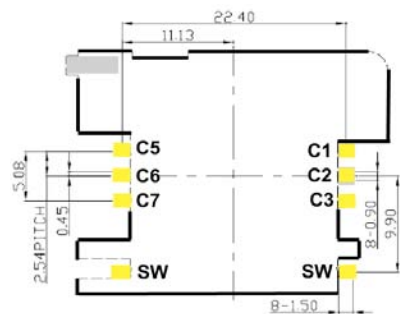

Connector Pin Definition

Pin	Definition	Pin	Definition
C1	POWER VOLTAGE	C2	RESET SIGNAL
C3	CLOCK SIGNAL	C5	GND
C6	VPP:PROGRAM VOLTAGE	C7	I/O
SW	Contact present switch		

Bluetooth Connector

Connector location: J7



Pin	Definition	Pin	Definition
1	GND	2	USB_6P_L
3	USB_6N_L	4	NC
5	NC	6	BT_AUDIO_EN_R
7	NC	8	BT_3.3V
9	NC	10	GND

CHAPTER 3: SYSTEM SETUP

Removing the Chassis Cover

 Prior to removing the chassis cover, make sure the unit's power is off and disconnected from the power sources to prevent electric shock or system damage.

1. The screws on the cover are used to secure the cover to the chassis. Remove these screws and put them in a safe place for later use.



Front View



Rear View



Bottom View

2. Lift the cover upward then remove it from the chassis.



Installing a GPRS/UMTS/HSDPA Module

1. The Mini PCI Express slot shown below is used to install a 3.5G communication module such as GPRS, UMTS or HSDPA module.

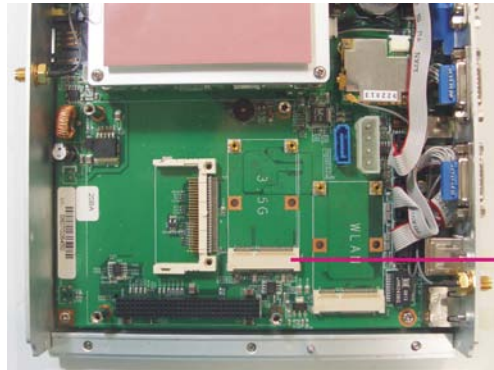

Mini PCI Express slot

2. Insert the module into the Mini PCI Express slot at a 45 degrees angle until the gold-plated connector on the edge of the module completely disappears inside the slot.

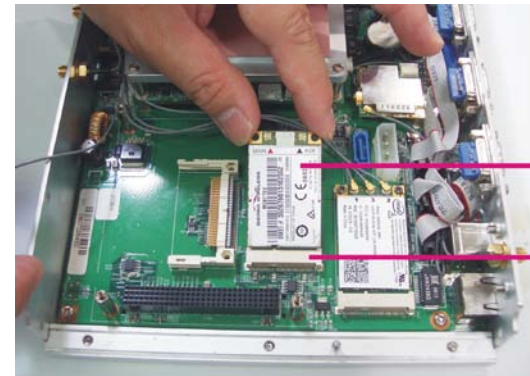

GPRS/UMTS/HSDPA module

Mini PCI Express slot

3. Push the module down then secure it with mounting screws.



4. Attach one end of the RF cable onto the module.



Attach RF cable to the module



5. The photo below shows one end of the RF cable properly attached onto the module.



6. Mount the other end of the cable to the antenna mounting hole located at the front panel of the chassis.



RF cable mounted at the front panel

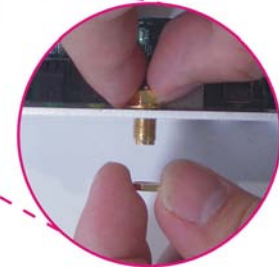

Installing a Wireless LAN Module

1. The Mini PCI Express slot shown below is used to install a wireless LAN module.

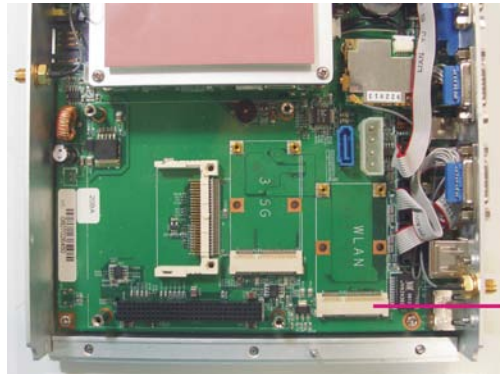

Mini PCI Express slot

2. Insert the wireless LAN module into the Mini PCI Express slot at a 45 degrees angle until the gold-plated connector on the edge of the module completely disappears inside the slot.

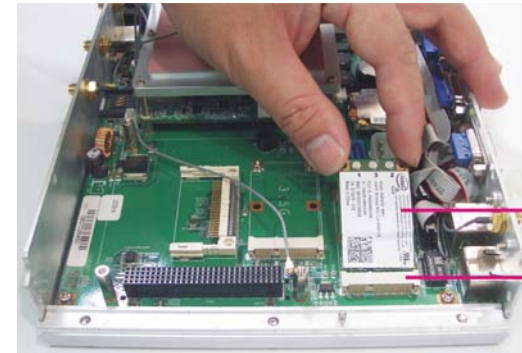

Wireless LAN module

Mini PCI Express slot

3. Push the module down then secure it with mounting screws.

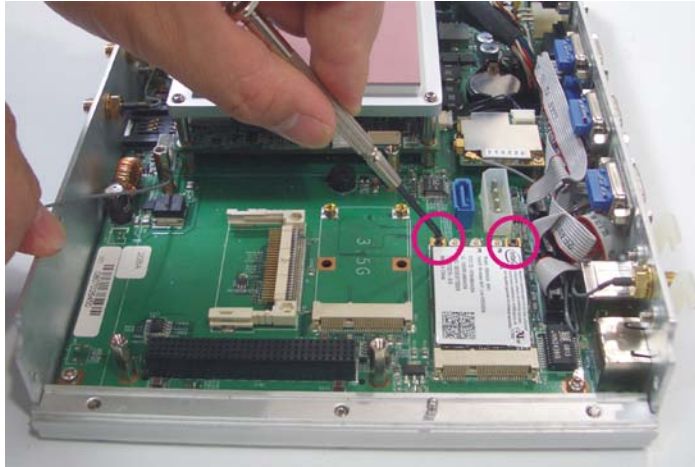

4. Attach one end of the RF cable onto the module.

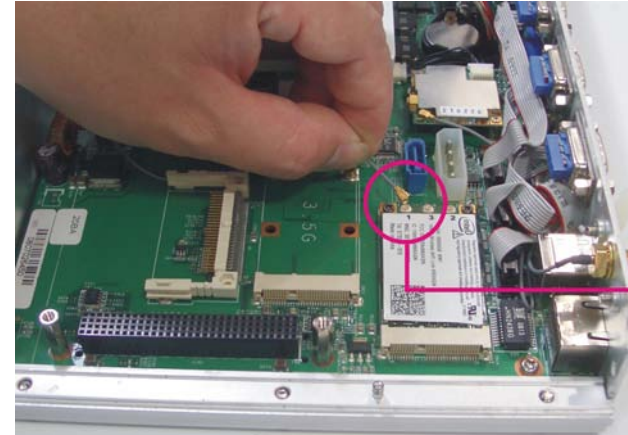

Attach RF cable to the module

5. The photo below shows one end of the RF cable properly attached onto the module.



6. Mount the other end of the cable to the antenna mounting hole located at the front panel of the chassis.



RF cable mounted at the front panel

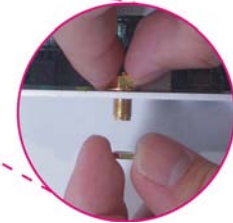

Installing a Bluetooth Module

1. The USB header shown below is used to install a Bluetooth module.

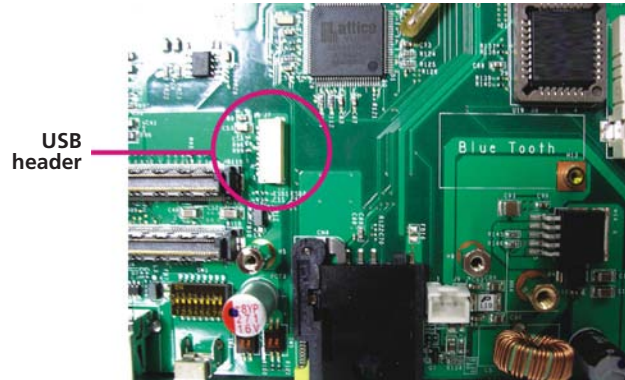

2. Install the provided mounting stud as shown in the illustration below.

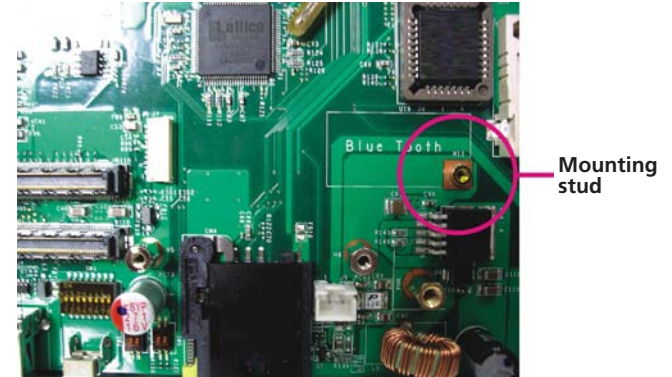

3. Insert the Bluetooth module's cable connector into the USB header. Push the module down then secure it with a mounting screw.

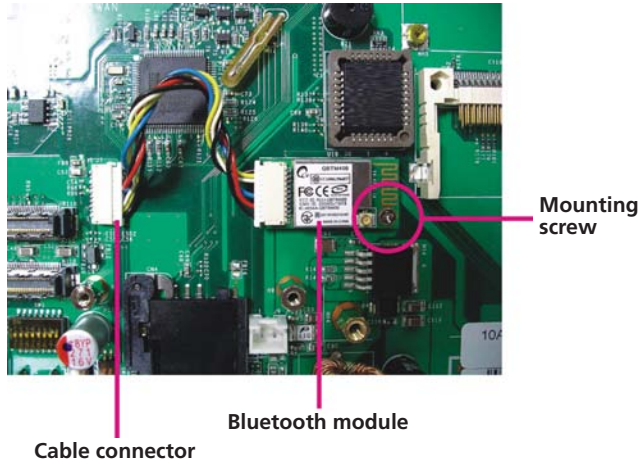

4. Attach one end of the RF cable onto the module.

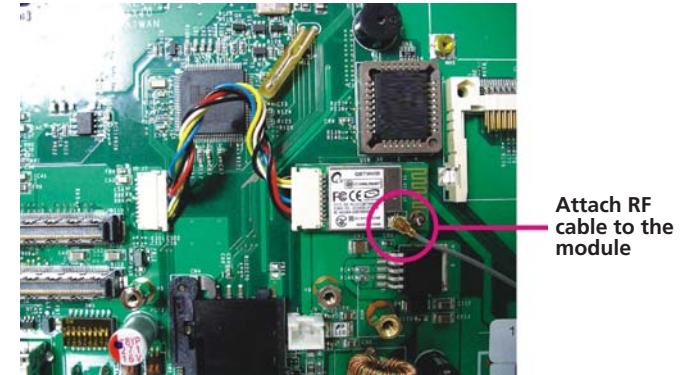

5. Mount the other end of the cable to the Bluetooth mounting hole located at the front panel of the chassis.