

*EMC Test Report
Application for Grant of Equipment Authorization
Industry Canada RSS-Gen Issue 3 / RSS 210 Issue 8
FCC Part 15 Subpart C*

Model: MASM-02199 Bluetooth Module

IC CERTIFICATION #: 6384A-MASM02199
FCC ID: YHEMASM-02199

FCC APPLICANT: Ablelink Electronics Ltd.
2030 Lindell Avenue
Nashville, TN 37203

IC APPLICANT: Griffin Technology
2030 Lindell Avenue
Nashville, TN 37203

TEST SITE(S): National Technical Systems - Silicon Valley
41039 Boyce Road.
Fremont, CA. 94538-2435

IC SITE REGISTRATION #: 2845B-5, 2845B-7

REPORT DATE: September 23, 2013

REISSUE DATE: July 15, 2014

FINAL TEST DATES: July 12, 15, 17 and 19, 2013

TOTAL NUMBER OF PAGES: 55

PROGRAM MGR /
TECHNICAL REVIEWER:

QUALITY ASSURANCE DELEGATE /
FINAL REPORT PREPARER:



Mark E Hill
Staff Engineer



David Guidotti
Senior Technical Writer



National Technical Systems - Silicon Valley is accredited by the A2LA, certificate number 0214.26, to perform the test(s) listed in this report, except where noted otherwise. This report and the information contained herein represent the results of testing test articles identified and selected by the client performed to specifications and/or procedures selected by the client. National Technical Systems (NTS) makes no representations, expressed or implied, that such testing is adequate (or inadequate) to demonstrate efficiency, performance, reliability, or any other characteristic of the articles being tested, or similar products. This report should not be relied upon as an endorsement or certification by NTS of the equipment tested, nor does it represent any statement whatsoever as to its merchantability or fitness of the test article, or similar products, for a particular purpose. This report shall not be reproduced except in full

REVISION HISTORY

Rev#	Date	Comments	Modified By
-	September 23, 2013	First release	
1	June 30, 2014	Revised to add references to Ablelink, update model number	David Guidotti Mark Hill
2	July 15, 2015	Clarified test dates in the appendix	Mark Hill

TABLE OF CONTENTS

REVISION HISTORY2

TABLE OF CONTENTS3

SCOPE.....4

OBJECTIVE4

STATEMENT OF COMPLIANCE.....5

DEVIATIONS FROM THE STANDARDS.....5

TEST RESULTS SUMMARY6

 FREQUENCY HOPPING SPREAD SPECTRUM (2400 – 2483.5 MHZ, 75 CHANNELS OR MORE)6

 GENERAL REQUIREMENTS APPLICABLE TO ALL BANDS7

 MEASUREMENT UNCERTAINTIES8

EQUIPMENT UNDER TEST (EUT) DETAILS.....9

 GENERAL.....9

 ANTENNA SYSTEM9

 ENCLOSURE.....9

 MODIFICATIONS.....9

 SUPPORT EQUIPMENT9

 EUT INTERFACE PORTS10

 EUT OPERATION10

TEST SITE.....11

 GENERAL INFORMATION11

 CONDUCTED EMISSIONS CONSIDERATIONS11

 RADIATED EMISSIONS CONSIDERATIONS11

MEASUREMENT INSTRUMENTATION12

 RECEIVER SYSTEM12

 INSTRUMENT CONTROL COMPUTER12

 LINE IMPEDANCE STABILIZATION NETWORK (LISN).....12

 FILTERS/ATTENUATORS13

 ANTENNAS.....13

 ANTENNA MAST AND EQUIPMENT TURNTABLE13

 INSTRUMENT CALIBRATION.....13

TEST PROCEDURES14

 EUT AND CABLE PLACEMENT14

 CONDUCTED EMISSIONS.....14

 RADIATED EMISSIONS.....15

 CONDUCTED EMISSIONS FROM ANTENNA PORT17

 BANDWIDTH MEASUREMENTS17

 SPECIFICATION LIMITS AND SAMPLE CALCULATIONS18

 CONDUCTED EMISSIONS SPECIFICATION LIMITS: FCC 15.207; FCC 15.107(A), RSS GEN18

 GENERAL TRANSMITTER RADIATED EMISSIONS SPECIFICATION LIMITS19

 RECEIVER RADIATED SPURIOUS EMISSIONS SPECIFICATION LIMITS19

 OUTPUT POWER LIMITS – FHSS SYSTEMS20

 TRANSMIT MODE SPURIOUS RADIATED EMISSIONS LIMITS – FHSS AND DTS SYSTEMS.....20

 SAMPLE CALCULATIONS - CONDUCTED EMISSIONS20

 SAMPLE CALCULATIONS - RADIATED EMISSIONS.....21

 SAMPLE CALCULATIONS - FIELD STRENGTH TO EIRP CONVERSION.....22

APPENDIX A TEST EQUIPMENT CALIBRATION DATA23

APPENDIX B TEST DATA24

END OF REPORT55

SCOPE

An electromagnetic emissions test has been performed on the Griffin Technology model MASM-02199 Bluetooth Module, pursuant to the following rules:

Industry Canada RSS-Gen Issue 3
RSS 210 Issue 8 “Low-power Licence-exempt Radiocommunication Devices (All Frequency Bands): Category I Equipment”
FCC Part 15 Subpart C

Conducted and radiated emissions data has been collected, reduced, and analyzed within this report in accordance with measurement guidelines set forth in the following reference standards and as outlined in National Technical Systems - Silicon Valley test procedures:

ANSI C63.10-2009
FHSS test procedure DA 00-0705A1

The intentional radiator above has been tested in a simulated typical installation to demonstrate compliance with the relevant Industry Canada performance and procedural standards.

Final system data was gathered in a mode that tended to maximize emissions by varying orientation of EUT, orientation of power and I/O cabling, antenna search height, and antenna polarization.

Every practical effort was made to perform an impartial test using appropriate test equipment of known calibration. All pertinent factors have been applied to reach the determination of compliance.

OBJECTIVE

The primary objective of the manufacturer is compliance with the regulations outlined in the previous section.

Prior to marketing in the USA, all unlicensed transmitters and transceivers require certification. Receive-only devices operating between 30 MHz and 960 MHz are subject to either certification or a manufacturer’s declaration of conformity, with all other receive-only devices exempt from the technical requirements.

Prior to marketing in Canada, Class I transmitters, receivers and transceivers require certification. Class II devices are required to meet the appropriate technical requirements but are exempt from certification requirements.

Certification is a procedure where the manufacturer submits test data and technical information to a certification body and receives a certificate or grant of equipment authorization upon successful completion of the certification body’s review of the submitted documents. Once the equipment authorization has been obtained, the label indicating compliance must be attached to all identical units, which are subsequently manufactured.

Maintenance of compliance is the responsibility of the manufacturer. Any modification of the product which may result in increased emissions should be checked to ensure compliance has been maintained (i.e., printed circuit board layout changes, different line filter, different power supply, harnessing or I/O cable changes, etc.).

STATEMENT OF COMPLIANCE

The tested sample of Griffin Technology model MASM-02199 Bluetooth Module complied with the requirements of the following regulations:

Industry Canada RSS-Gen Issue 3
RSS 210 Issue 8 “Low-power Licence-exempt Radiocommunication Devices (All Frequency Bands): Category I Equipment”
FCC Part 15 Subpart C

Maintenance of compliance is the responsibility of the manufacturer. Any modifications to the product should be assessed to determine their potential impact on the compliance status of the device with respect to the standards detailed in this test report.

The test results recorded herein are based on a single type test of Griffin Technology model MASM-02199 Bluetooth Module and therefore apply only to the tested sample. The sample was selected and prepared by Michael O'Connor of Griffin Technology.

DEVIATIONS FROM THE STANDARDS

No deviations were made from the published requirements listed in the scope of this report.

TEST RESULTS SUMMARY

FREQUENCY HOPPING SPREAD SPECTRUM (2400 – 2483.5 MHz, 75 channels or more)

FCC Rule Part	RSS Rule Part	Description	Measured Value / Comments	Limit / Requirement	Result
15.247 (a) (1)	RSS 210 A8.1 (1)	20dB Bandwidth	Basic: 920 kHz EDR: 1269 kHz	Channel spacing > 2/3rds of 20dB BW	Complies
		Channel Separation	1 MHz		Complies
15.247 (a) (1) (iii)	RSS 210 A8.1 (4)	Channel Dwell Time (<i>average time of occupancy</i>)	Device complies with Bluetooth 2.1 specification with a minimum of 20 hopping channels	<0.4 second within a period of 0.4 x number of channels	Complies
15.247 (a) (1) (iii)	RSS 210 A8.1 (4)	Number of Channels		15 or more	Complies
15.247 (a) (1)	RSS 210 A8.1 (1)	Channel Utilization	The system uses the BlueTooth algorithm and, therefore, meets all requirements for channel utilization.	All channels shall, on average, be used equally	Complies
15.247 (b) (3)	RSS 210 A8.4 (2)	Output Power (multipoint systems)	Basic: 3.3 dBm (0.002 W) EDR: 1.9 dBm (0.002 W) EIRP = 0.005 W ^{Note 1}	1 Watt, EIRP limited to 4 Watts.	Complies
15.247(c)	RSS 210 A8.5	Spurious Emissions – 30MHz – 25GHz	All spurious emissions < -20dBc	< -20dBc	Complies
15.247(c) / 15.209	RSS 210 A8.5 Table 2, 3	Radiated Spurious Emissions 30MHz – 25GHz	45.9 dBμV/m @ 4804.1 MHz (-8.1 dB)	15.207 in restricted bands, all others < -20dBc	Complies
15.247 (a) (1)	RSS 210 A8.1(2)	Receiver bandwidth	Refer to operational description	Shall match the channel bandwidth	Complies
Note 1: EIRP calculated using antenna gain of 4 dBi					

GENERAL REQUIREMENTS APPLICABLE TO ALL BANDS

FCC Rule Part	RSS Rule part	Description	Measured Value / Comments	Limit / Requirement	Result (margin)
15.203	-	RF Connector	EUT uses an onboard chip antenna	Unique or integral antenna required	Complies
15.207	RSS GEN Table 2	AC Conducted Emissions	32.3 dB μ V @ 7.229 MHz (-17.7 dB)	Refer to page 18	Complies
15.109	RSS GEN 7.2.3 Table 1	Receiver spurious emissions	N/A – EUT tunes above 960MHz		
15.247 (b) (5) 15.407 (f)	RSS 102	RF Exposure Requirements	Refer to MPE calculations in Exhibit 11, RSS 102 declaration and User Manual statements.	Refer to OET 65, FCC Part 1 and RSS 102	Complies
-	RSP 100 RSS GEN 7.1.5	User Manual		Statement required regarding non-interference	Complies
-	RSP 100 RSS GEN 7.1.5	User Manual		Statement for products with detachable antenna	Complies
-	RSP 100 RSS GEN 4.4.1	99% Bandwidth	Basic: 876 kHz EDR: 1170 kHz	Information only	N/A

MEASUREMENT UNCERTAINTIES

ISO/IEC 17025 requires that an estimate of the measurement uncertainties associated with the emissions test results be included in the report. The measurement uncertainties given below are based on a 95% confidence level and were calculated in accordance with UKAS document LAB 34.

Measurement Type	Measurement Unit	Frequency Range	Expanded Uncertainty
RF power, conducted (power meter)	dBm	25 to 7000 MHz	± 0.52 dB
RF power, conducted (Spectrum analyzer)	dBm	25 to 7000 MHz	± 0.7 dB
Conducted emission of transmitter	dBm	25 to 26500 MHz	± 0.7 dB
Conducted emission of receiver	dBm	25 to 26500 MHz	± 0.7 dB
Radiated emission (substitution method)	dBm	25 to 26500 MHz	± 2.5 dB
Radiated emission (field strength)	dB μ V/m	25 to 1000 MHz	± 3.6 dB
		1000 to 40000 MHz	± 6.0 dB
Conducted Emissions (AC Power)	dB μ V	0.15 to 30 MHz	± 2.4 dB

EQUIPMENT UNDER TEST (EUT) DETAILS

GENERAL

The Griffin Technology model MASM-02199 Bluetooth Module is a Bluetooth 2.1 module that supports basic and EDR operational modes.

The sample was received on July 12, 2013 and tested on July 12, 15, 17 and 19, 2013. The EUT consisted of the following component(s):

Company	Model	Description	Serial Number	FCC ID
Griffin Technology	MASM-02199 (BC5) Bluetooth module	Bluetooth module	Prototype	YHEMASM-02199

ANTENNA SYSTEM

EUT uses an onboard chip antenna, 4dBi max gain.

ENCLOSURE

The EUT has no enclosure. It is designed to be installed within the enclosure of a host system.

MODIFICATIONS

No modifications were made to the EUT during the time the product was at NTS Silicon Valley.

SUPPORT EQUIPMENT

The following equipment was used as support equipment for testing:

Company	Model	Description	Serial Number	FCC ID
Agilent	E3610A	DC Power Supply	MY40011740	N/A
Griffin	Shakeout Proto Board	Test Fixture	-	N/A
Apple	MacBook Pro	Laptop Computer	W893642T7XJ	N/A
Apple	MagSafe Power Adapter	AC/DC Adapter	-	N/A

No remote support equipment was used during testing.

EUT INTERFACE PORTS

The I/O cabling configuration during testing was as follows:

Port	Connected To	Description	Cable(s)	
			Shielded or Unshielded	Length(m)
Test Fixture – USB	Laptop	Multiconductor	Shielded	1.5m
Test Fixture – Power	Agilent DC Power Supply	2wire	Unshielded	1.0m
Laptop Computer – DC power	AC/DC Adapter	Multiconductor	Shielded	1.5m

EUT OPERATION

The EUT was exercised by using BlueTest3 test utility. Unless otherwise noted, the EUT was configured to transmit continuously on the noted channel at the maximum power setting.

TEST SITE

GENERAL INFORMATION

Final test measurements were taken at the test sites listed below. Pursuant to section 2.948 of the FCC's Rules and section 3.3 of RSP-100, construction, calibration, and equipment data has been filed with the Commission and with industry Canada.

Site	Registration Numbers		Location
	FCC	Canada	
Chamber 5	211948	2845B-5	41039 Boyce Road Fremont, CA 94538-2435
Chamber 7	A2LA accreditation	2845B-7	

ANSI C63.4 recommends that ambient noise at the test site be at least 6 dB below the allowable limits. Ambient levels are below this requirement. The test site(s) contain separate areas for radiated and conducted emissions testing. Considerable engineering effort has been expended to ensure that the facilities conform to all pertinent requirements of ANSI C63.4.

CONDUCTED EMISSIONS CONSIDERATIONS

Conducted emissions testing is performed in conformance with ANSI C63.10. Measurements are made with the EUT connected to the public power network through a nominal, standardized RF impedance, which is provided by a line impedance stabilization network, known as a LISN. A LISN is inserted in series with each current-carrying conductor in the EUT power cord.

RADIATED EMISSIONS CONSIDERATIONS

The FCC has determined that radiation measurements made in a shielded enclosure are not suitable for determining levels of radiated emissions. Radiated measurements are performed in an open field environment or in a semi-anechoic chamber. The test sites are maintained free of conductive objects within the CISPR defined elliptical area incorporated in ANSI C63.4 guidelines and meet the Normalized Site Attenuation (NSA) requirements of ANSI C63.4.

MEASUREMENT INSTRUMENTATION

RECEIVER SYSTEM

An EMI receiver as specified in CISPR 16-1-1 is used for emissions measurements. The receivers used can measure over the frequency range of 9 kHz up to 2000 MHz. These receivers allow both ease of measurement and high accuracy to be achieved. The receivers have Peak, Average, and CISPR (Quasi-peak) detectors built into their design so no external adapters are necessary. The receiver automatically sets the required bandwidth for the CISPR detector used during measurements. If the repetition frequency of the signal being measured is below 20Hz, peak measurements are made in lieu of Quasi-Peak measurements.

For measurements above the frequency range of the receivers, a spectrum analyzer is utilized because it provides visibility of the entire spectrum along with the precision and versatility required to support engineering analysis. Average measurements above 1000MHz are performed on the spectrum analyzer using the linear-average method with a resolution bandwidth of 1 MHz and a video bandwidth of 10 Hz, unless the signal is pulsed in which case the average (or video) bandwidth of the measuring instrument is reduced to onset of pulse desensitization and then increased.

INSTRUMENT CONTROL COMPUTER

The receivers utilize either a Rohde & Schwarz EZM Spectrum Monitor/Controller or contain an internal Spectrum Monitor/Controller to view and convert the receiver measurements to the field strength at an antenna or voltage developed at the LISN measurement port, which is then compared directly with the appropriate specification limit. This provides faster, more accurate readings by performing the conversions described under Sample Calculations within the Test Procedures section of this report. Results are printed in a graphic and/or tabular format, as appropriate. A personal computer is used to record all measurements made with the receivers.

The Spectrum Monitor provides a visual display of the signal being measured. In addition, the controller or a personal computer run automated data collection programs which control the receivers. This provides added accuracy since all site correction factors, such as cable loss and antenna factors are added automatically.

LINE IMPEDANCE STABILIZATION NETWORK (LISN)

Line conducted measurements utilize a fifty microhenry Line Impedance Stabilization Network as the monitoring point. The LISN used also contains a 250 uH CISPR adapter. This network provides for calibrated radio frequency noise measurements by the design of the internal low pass and high pass filters on the EUT and measurement ports, respectively.

FILTERS/ATTENUATORS

External filters and precision attenuators are often connected between the receiving antenna or LISN and the receiver. This eliminates saturation effects and non-linear operation due to high amplitude transient events.

ANTENNAS

A loop antenna is used below 30 MHz. For the measurement range 30 MHz to 1000 MHz either a combination of a biconical antenna and a log periodic or a bi-log antenna is used. Above 1000 MHz, horn antennas are used. The antenna calibration factors to convert the received voltage to an electric field strength are included with appropriate cable loss and amplifier gain factors to determine an overall site factor, which is then programmed into the test receivers or incorporated into the test software.

ANTENNA MAST AND EQUIPMENT TURNTABLE

The antennas used to measure the radiated electric field strength are mounted on a non-conductive antenna mast equipped with a motor-drive to vary the antenna height. Measurements below 30 MHz are made with the loop antenna at a fixed height of 1m above the ground plane.

ANSI C63.10 specifies that the test height above ground for table mounted devices shall be 80 centimeters. Floor mounted equipment shall be placed on the ground plane if the device is normally used on a conductive floor or separated from the ground plane by insulating material from 3 to 12 mm if the device is normally used on a non-conductive floor as specified in ANSI C63.4. During radiated measurements, the EUT is positioned on a motorized turntable in conformance with this requirement.

INSTRUMENT CALIBRATION

All test equipment is regularly checked to ensure that performance is maintained in accordance with the manufacturer's specifications. All antennas are calibrated at regular intervals with respect to tuned half-wave dipoles. An exhibit of this report contains the list of test equipment used and calibration information.

TEST PROCEDURES

EUT AND CABLE PLACEMENT

The regulations require that interconnecting cables be connected to the available ports of the unit and that the placement of the unit and the attached cables simulate the worst case orientation that can be expected from a typical installation, so far as practicable. To this end, the position of the unit and associated cabling is varied within the guidelines of ANSI C63.10, and the worst-case orientation is used for final measurements.

CONDUCTED EMISSIONS

Conducted emissions are measured at the plug end of the power cord supplied with the EUT. Excess power cord length is wrapped in a bundle between 30 and 40 centimeters in length near the center of the cord. Preliminary measurements are made to determine the highest amplitude emission relative to the specification limit for all the modes of operation. Placement of system components and varying of cable positions are performed in each mode. A final peak mode scan is then performed in the position and mode for which the highest emission was noted on all current carrying conductors of the power cord.

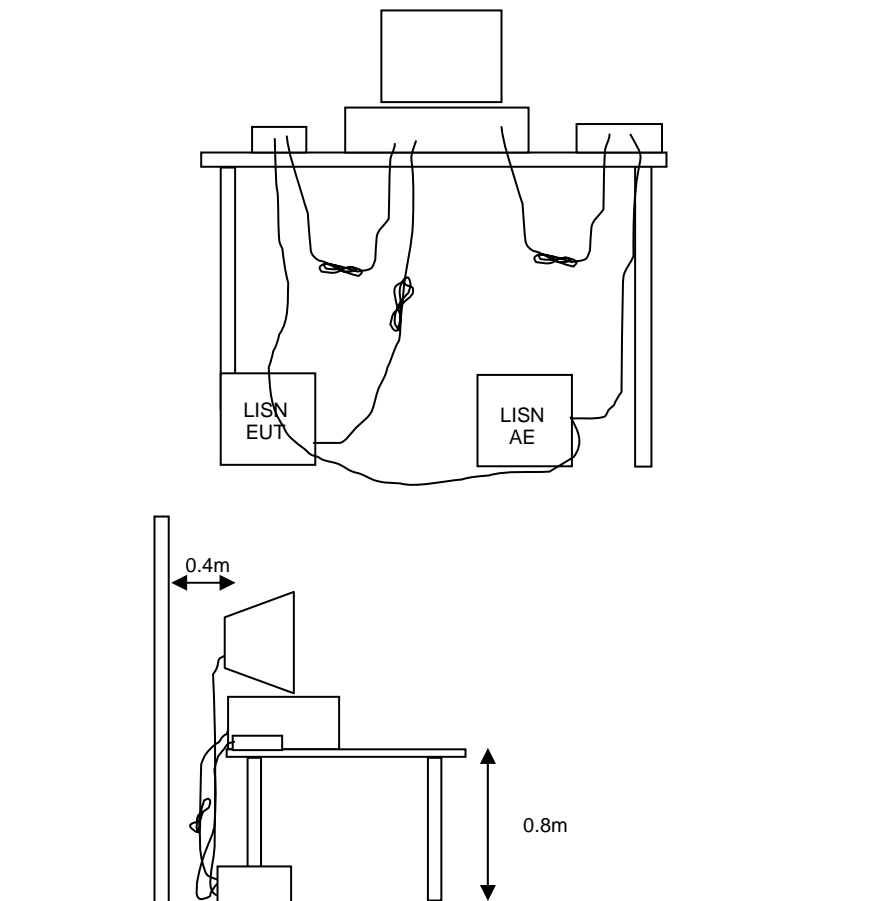

Figure 1 Typical Conducted Emissions Test Configuration

RADIATED EMISSIONS

A preliminary scan of the radiated emissions is performed in which all significant EUT frequencies are identified with the system in a nominal configuration. At least two scans are performed, one scan for each antenna polarization (horizontal and vertical; loop parallel and perpendicular to the EUT). During the preliminary scans, the EUT is rotated through 360°, the antenna height is varied (for measurements above 30 MHz) and cable positions are varied to determine the highest emission relative to the limit. Preliminary scans may be performed in a fully anechoic chamber for the purposes of identifying the frequencies of the highest emissions from the EUT.

A speaker is provided in the receiver to aid in discriminating between EUT and ambient emissions. Other methods used during the preliminary scan for EUT emissions involve scanning with near field magnetic loops, monitoring I/O cables with RF current clamps, and cycling power to the EUT.

Final maximization is a phase in which the highest amplitude emissions identified in the spectral search are viewed while the EUT azimuth angle is varied from 0 to 360 degrees relative to the receiving antenna. The azimuth, which results in the highest emission is then maintained while varying the antenna height from one to four meters (for measurements above 30 MHz, measurements below 30 MHz are made with the loop antenna at a fixed height of 1m). The result is the identification of the highest amplitude for each of the highest peaks. Each recorded level is corrected in the receiver using appropriate factors for cables, connectors, antennas, and preamplifier gain.

When testing above 18 GHz, the receive antenna is located at 1 meter from the EUT and the antenna height is restricted to a maximum of 2.5 meters.

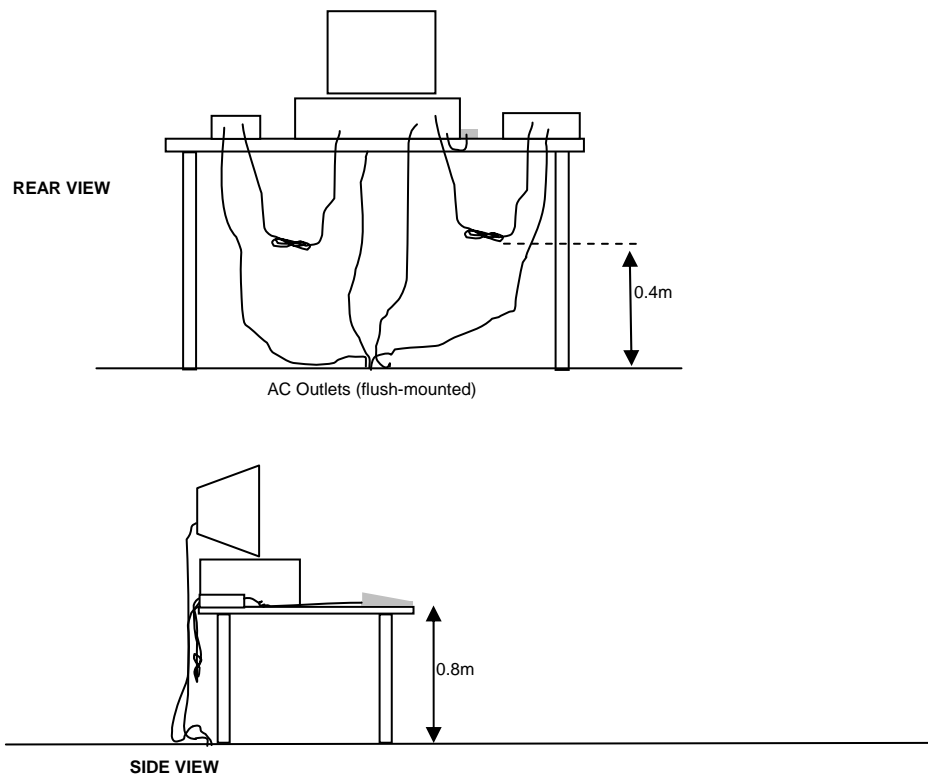

Typical Test Configuration for Radiated Field Strength Measurements

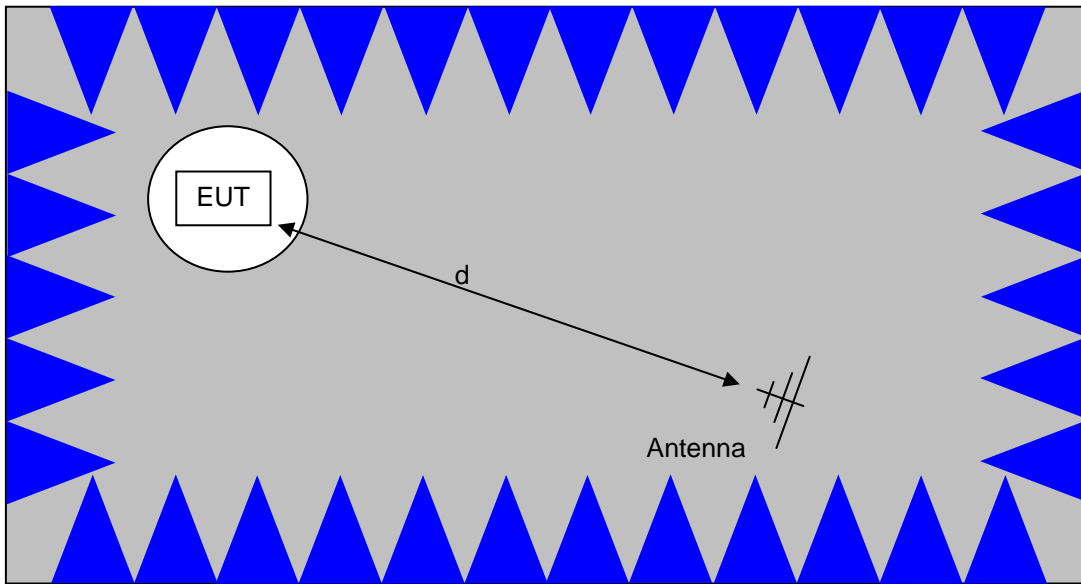

The anechoic materials on the walls and ceiling ensure compliance with the normalized site attenuation requirements of CISPR 16 / CISPR 22 / ANSI C63.4 for an alternate test site at the measurement distances used.

Floor-standing equipment is placed on the floor with insulating supports between the unit and the ground plane.

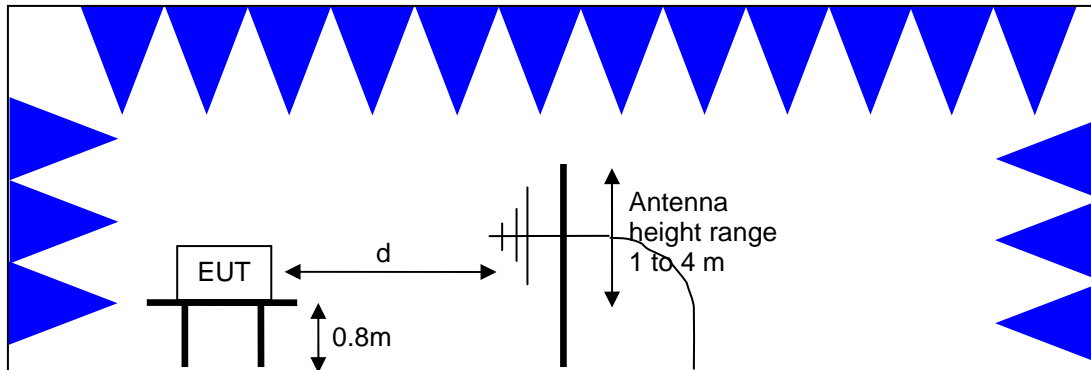

Test Configuration for Radiated Field Strength Measurements
Semi-Anechoic Chamber, Plan and Side Views

CONDUCTED EMISSIONS FROM ANTENNA PORT

Direct measurements of power, bandwidth and power spectral density are performed, where possible, with the antenna port of the EUT connected to either the power meter or spectrum analyzer via a suitable attenuator and/or filter. These are used to ensure that the front end of the measurement instrument is not overloaded by the fundamental transmission.

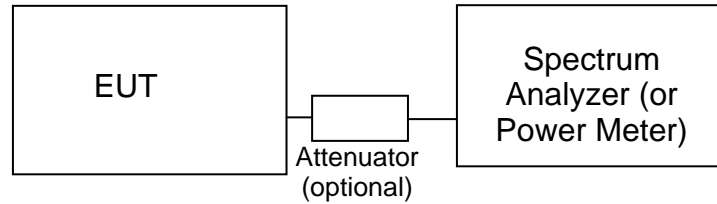

Test Configuration for Antenna Port Measurements

Measurement bandwidths (video and resolution) are set in accordance with the relevant standards and NTS Silicon Valley's test procedures for the type of radio being tested. When power measurements are made using a resolution bandwidth less than the signal bandwidth the power is calculated by summing the power across the signal bandwidth using either the analyzer channel power function or by capturing the trace data and calculating the power using software. In both cases the summed power is corrected to account for the equivalent noise bandwidth (ENBW) of the resolution bandwidth used.

If power averaging is used (typically for certain digital modulation techniques), the EUT is configured to transmit continuously. Power averaging is performed using either the built-in function of the analyzer or, if the analyzer does not feature power averaging, using external software. In both cases the average power is calculated over a number of sweeps (typically 100). When the EUT cannot be configured to continuously transmit then either the analyzer is configured to perform a gated sweep to ensure that the power is averaged over periods that the device is transmitting or power averaging is disabled and a max-hold feature is used.

If a power meter is used to make output power measurements the sensor head type (peak or average) is stated in the test data table.

BANDWIDTH MEASUREMENTS

The 6dB, 20dB, 26dB and/or 99% signal bandwidth are measured using the bandwidths recommended by ANSI C63.10 and RSS GEN.

SPECIFICATION LIMITS AND SAMPLE CALCULATIONS

The limits for conducted emissions are given in units of microvolts, and the limits for radiated emissions are given in units of microvolts per meter at a specified test distance. Data is measured in the logarithmic form of decibels relative to one microvolt, or dB microvolts (dBuV). For radiated emissions, the measured data is converted to the field strength at the antenna in dB microvolts per meter (dBuV/m). The results are then converted to the linear forms of uV and uV/m for comparison to published specifications.

For reference, converting the specification limits from linear to decibel form is accomplished by taking the base ten logarithm, then multiplying by 20. These limits in both linear and logarithmic form are as follows:

CONDUCTED EMISSIONS SPECIFICATION LIMITS: FCC 15.207; FCC 15.107(a), RSS GEN

The table below shows the limits for the emissions on the AC power line from an intentional radiator and a receiver.

Frequency (MHz)	Average Limit (dBuV)	Quasi Peak Limit (dBuV)
0.150 to 0.500	Linear decrease on logarithmic frequency axis between 56.0 and 46.0	Linear decrease on logarithmic frequency axis between 66.0 and 56.0
0.500 to 5.000	46.0	56.0
5.000 to 30.000	50.0	60.0

GENERAL TRANSMITTER RADIATED EMISSIONS SPECIFICATION LIMITS

The table below shows the limits for the spurious emissions from transmitters that fall in restricted bands¹ (with the exception of transmitters operating under FCC Part 15 Subpart D and RSS 210 Annex 9), the limits for all emissions from a low power device operating under the general rules of RSS 310 (tables 3 and 4), RSS 210 (table 2) and FCC Part 15 Subpart C section 15.209.

Frequency Range (MHz)	Limit (uV/m)	Limit (dBuV/m @ 3m)
0.009-0.490	2400/F _{KHz} @ 300m	67.6-20*log ₁₀ (F _{KHz}) @ 300m
0.490-1.705	24000/F _{KHz} @ 30m	87.6-20*log ₁₀ (F _{KHz}) @ 30m
1.705 to 30	30 @ 30m	29.5 @ 30m
30 to 88	100 @ 3m	40 @ 3m
88 to 216	150 @ 3m	43.5 @ 3m
216 to 960	200 @ 3m	46.0 @ 3m
Above 960	500 @ 3m	54.0 @ 3m

RECEIVER RADIATED SPURIOUS EMISSIONS SPECIFICATION LIMITS

The table below shows the limits for the spurious emissions from receivers as detailed in FCC Part 15.109, RSS 210 Table 2, RSS GEN Table 1 and RSS 310 Table 3. Note that receivers operating outside of the frequency range 30 MHz – 960 MHz are exempt from the requirements of 15.109.

Frequency Range (MHz)	Limit (uV/m @ 3m)	Limit (dBuV/m @ 3m)
30 to 88	100	40
88 to 216	150	43.5
216 to 960	200	46.0
Above 960	500	54.0

¹ The restricted bands are detailed in FCC 15.203, RSS 210 Table 1 and RSS 310 Table 2

OUTPUT POWER LIMITS – FHSS SYSTEMS

The table below shows the limits for output power based on the number of channels available for the hopping system.

Operating Frequency (MHz)	Number of Channels	Output Power
902 – 928	≥ 50	1 Watt (30 dBm)
902 – 928	25 to 49	0.25 Watts (24 dBm)
2400 – 2483.5	≥ 75	1 Watt (30 dBm)
2400 – 2483.5	< 75	0.125 Watts (21 dBm)
5725 – 5850	75	1 Watt (30 dBm)

The maximum permitted output power is reduced by 1dB for every dB the antenna gain exceeds 6dBi. Fixed point-to-point applications using the 5725 – 5850 MHz band are not subject to this restriction.

TRANSMIT MODE SPURIOUS RADIATED EMISSIONS LIMITS – FHSS and DTS SYSTEMS

The limits for unwanted (spurious) emissions from the transmitter falling in the restricted bands are those specified in the general limits sections of FCC Part 15 and RSS 210. All other unwanted (spurious) emissions shall be at least 20dB below the level of the highest in-band signal level (30dB if the power is measured using the sample detector/power averaging method).

SAMPLE CALCULATIONS - CONDUCTED EMISSIONS

Receiver readings are compared directly to the conducted emissions specification limit (decibel form) as follows:

$$R_r - S = M$$

where:

R_r = Receiver Reading in dBuV

S = Specification Limit in dBuV

M = Margin to Specification in +/- dB

SAMPLE CALCULATIONS - RADIATED EMISSIONS

Receiver readings are compared directly to the specification limit (decibel form). The receiver internally corrects for cable loss, preamplifier gain, and antenna factor. The calculations are in the reverse direction of the actual signal flow, thus cable loss is added and the amplifier gain is subtracted. The Antenna Factor converts the voltage at the antenna coaxial connector to the field strength at the antenna elements.

A distance factor, when used for electric field measurements above 30MHz, is calculated by using the following formula:

$$F_d = 20 * \text{LOG}_{10} (D_m/D_s)$$

where:

$$F_d = \text{Distance Factor in dB}$$

$$D_m = \text{Measurement Distance in meters}$$

$$D_s = \text{Specification Distance in meters}$$

For electric field measurements below 30MHz the extrapolation factor is either determined by making measurements at multiple distances or a theoretical value is calculated using the formula:

$$F_d = 40 * \text{LOG}_{10} (D_m/D_s)$$

Measurement Distance is the distance at which the measurements were taken and Specification Distance is the distance at which the specification limits are based. The antenna factor converts the voltage at the antenna coaxial connector to the field strength at the antenna elements.

The margin of a given emission peak relative to the limit is calculated as follows:

$$R_c = R_r + F_d$$

and

$$M = R_c - L_s$$

where:

$$R_r = \text{Receiver Reading in dBuV/m}$$

$$F_d = \text{Distance Factor in dB}$$

$$R_c = \text{Corrected Reading in dBuV/m}$$

$$L_s = \text{Specification Limit in dBuV/m}$$

$$M = \text{Margin in dB Relative to Spec}$$

SAMPLE CALCULATIONS - FIELD STRENGTH TO EIRP CONVERSION

Where the radiated electric field strength is expressed in terms of the equivalent isotropic radiated power (eirp), or where a field strength measurement of output power is made in lieu of a direct measurement, the following formula is used to convert between eirp and field strength at a distance of d (meters) from the equipment under test:

$$E = \frac{1000000 \sqrt{30 P}}{d} \quad \text{microvolts per meter}$$

where P is the eirp (Watts)

For a measurement at 3m the conversion from a logarithmic value for field strength (dBuV/m) to an eirp power (dBm) is -95.3dB.

Appendix A Test Equipment Calibration Data

Conducted Emissions - AC Power Ports, 13-Jul-13

<u>Manufacturer</u>	<u>Description</u>	<u>Model</u>	<u>Asset #</u>	<u>Cal Due</u>
Rohde & Schwarz	Pulse Limiter	ESH3 Z2	1594	5/15/2014
Rohde & Schwarz	EMI Test Receiver, 20 Hz-40 GHz	ESIB40 (1088.7490.40)	2493	1/18/2014
Com-Power	9KHz-30MHz, 50uH, 15Aac, 10Adc, max	LI-215A	2671	5/24/2014
Com-Power	9KHz-30MHz, 50uH, 15Aac, 10Adc, max	LI-215A	2672	5/24/2014

Radiated Emissions, 1000 - 26,000 MHz, 16-Jul-13

<u>Manufacturer</u>	<u>Description</u>	<u>Model</u>	<u>Asset #</u>	<u>Cal Due</u>
EMCO	Antenna, Horn, 1-18 GHz	3115	487	7/19/2014
Micro-Tronics	Band Reject Filter, 2400-2500 MHz	BRM50702-02	1683	8/2/2013
Hewlett Packard	Head (Inc W1-W4, 1946 , 1947) Purple	84125C	1772	6/18/2014
A. H. Systems	Red System Horn, 18-40GHz	SAS-574, p/n: 2581	2161	6/10/2014
Hewlett Packard	Microwave Preamplifier, 1-26.5GHz	8449B	2199	2/19/2014
Hewlett Packard	SpecAn 9 kHz - 40 GHz, (SA40) Purple	8564E (84125C)	2415	8/10/2013

Fundamental Field Strength, 18-Jul-13

<u>Manufacturer</u>	<u>Description</u>	<u>Model</u>	<u>Asset #</u>	<u>Cal Due</u>
EMCO	Antenna, Horn, 1-18 GHz (SA40-Red)	3115	1142	8/23/2014
Rohde & Schwarz	EMI Test Receiver, 20 Hz-7 GHz	ESIB7	1756	6/8/2014

Radiated Spurious Emissions, 1000 - 11,000 MHz, 19-Jul-13

<u>Manufacturer</u>	<u>Description</u>	<u>Model</u>	<u>Asset #</u>	<u>Cal Due</u>
Hewlett Packard	Microwave Preamplifier, 1-26.5GHz	8449B	785	11/9/2013
Hewlett Packard	SpecAn 30 Hz -40 GHz, SV (SA40) Red	8564E (84125C)	1148	9/14/2013
EMCO	Antenna, Horn, 1-18 GHz	3115	1561	7/12/2014
Micro-Tronics	Band Reject Filter, 2400-2500 MHz	BRM50702-02	2238	10/4/2013
Rohde & Schwarz	EMI Test Receiver, 20 Hz-40 GHz	ESIB40 (1088.7490.40)	2493	1/18/2014

Appendix B Test Data

T92958 Pages 25 - 54



EMC Test Data

Client:	Griffin Technologies	Job Number:	J92951
Product:	MASM-02199 Bluetooth module (BC5)	T-Log Number:	T92958
		Project Manager:	Sheareen Jacobs
Contact:	Michael O'Connor	Project Coordinator:	Irene Rademacher
Emissions Standard(s):	FCC, RSS-210, EN300 328, AS/NZS 4268:2008, EN 301 489-17 V2.1.1	Class:	B
Immunity Standard(s):	EN301 489-1V1.8.1		-

EMC Test Data

For The

Griffin Technologies

Product

MASM-02199 Bluetooth module (BC5)

Date of Last Test: 7/19/2013



EMC Test Data

Client: Griffin Technologies	Job Number: J92951
Model: MASM-02199 Bluetooth module (BC5)	T-Log Number: T92958
	Project Manager: Sheareen Jacobs
Contact: Michael O'Connor	Project Coordinator: Irene Rademacher
Standard: FCC, RSS-210, EN300 328, AS/NZS 4268:2008, EN 301 489-17 V2.1.1	Class: N/A

RSS 210 and FCC 15.247 (DTS) Radiated Spurious Emissions

Test Specific Details

Objective: The objective of this test session is to perform final qualification testing of the EUT with respect to the specification listed above.

General Test Configuration

The EUT and all local support equipment were located on the turntable for radiated spurious emissions testing.

For radiated emissions testing the measurement antenna was located 3 meters from the EUT.

Ambient Conditions:

Temperature: 25 °C
Rel. Humidity: 40 %

Summary of Results - Device Operating in the 2400-2483.5 MHz Band

Run #	Mode	Channel	Power Setting	Measured Power	Test Performed	Limit	Result / Margin			
1a	Basic	low	255 / 63	-	Restricted Band Edge (2390 MHz)	FCC Part 15.209 / 15.247(c)	42.6 dBµV/m @ 2376.1 MHz (-11.4 dB)			
				-	Radiated Emissions, 1 - 11 GHz		45.9 dBµV/m @ 4804.1 MHz (-8.1 dB)			
1b		center		-	Radiated Emissions, 1 - 11 GHz		62.6 dBµV/m @ 4882.0 MHz (-11.4 dB)			
		1c		high	-		Restricted Band Edge (2483.5 MHz)	40.4 dBµV/m @ 2483.5 MHz (-13.6 dB)		
-					Radiated Emissions, 1 - 11 GHz		36.8 dBµV/m @ 4960.1 MHz (-17.2 dB)			
2a		EDR		low	255 / 63		-	Restricted Band Edge (2390 MHz)	FCC Part 15.209 / 15.247(c)	38.5 dBµV/m @ 2376.1 MHz (-15.5 dB)
							-	Radiated Emissions, 1 - 11 GHz		44.7 dBµV/m @ 1602.1 MHz (-9.3 dB)
2b				center			-	Radiated Emissions, 1 - 11 GHz		41.9 dBµV/m @ 1626.5 MHz (-12.1 dB)
				2c			high	-		Restricted Band Edge (2483.5 MHz)
-	Radiated Emissions, 1 - 11 GHz		57.1 dBµV/m @ 4960.0 MHz (-16.9 dB)							



EMC Test Data

Client:	Griffin Technologies	Job Number:	J92951
Model:	MASM-02199 Bluetooth module (BC5)	T-Log Number:	T92958
		Project Manager:	Sheareen Jacobs
Contact:	Michael O'Connor	Project Coordinator:	Irene Rademacher
Standard:	FCC, RSS-210, EN300 328, AS/NZS 4268:2008, EN 301 489-17 V2.1.1	Class:	N/A

Modifications Made During Testing

No modifications were made to the EUT during testing

Deviations From The Standard

No deviations were made from the requirements of the standard.

Procedure Comments:

Measurements performed in accordance with FCC Public Notice, DA 00-705 (modified by KDB 558074 D01 for average measurements above 1GHz)
 Preliminary testing indicated no radio related emissions below 1GHz.
 Peak measurements performed with: RBW=1MHz, VBW=3MHz, peak detector, max hold, auto sweep time
 Unless otherwise stated/noted, emission has duty cycle $\geq 98\%$ and was measured using RBW=1MHz, VBW=10Hz, peak detector, linear average mode. auto sweep time. max hold.

Mode	Data Rate	Duty Cycle (x)	Constant DC?	T (ms)	Pwr Cor Factor*	Lin Volt Cor Factor**	Min VBW for FS (Hz)
Basic	15, 339	77%	Yes	2.89	1.12	2.24	346.0
EDR	31, 1021	77.5%	Yes	2.89	1.11	2.22	346.0

Measurement Specific Notes:

Note 1:	Emission in non-restricted band, but limit of 15.209 used.
Note 2:	Emission in non-restricted band, the limit was set 20dB below the level of the fundamental and measured in 100kHz.
Note 3:	Emission has duty cycle $< 98\%$, but constant, average measurement performed: RBW=1MHz, VBW=10Hz, peak detector, linear averaging, auto sweep, trace average 100 traces, measurement corrected by Linear Voltage correction factor
Note 6:	Plots of the average and peak bandedge do not account for any duty cycle correction. Refer to the tabluar results for final measurements.
Note 7:	Average measurement further corrected based on BT dwell time in any 100ms window (see below), per DA 00-705

Client:	Griffin Technologies	Job Number:	J92951
Model:	MASM-02199 Bluetooth module (BC5)	T-Log Number:	T92958
		Project Manager:	Sheareen Jacobs
Contact:	Michael O'Connor	Project Coordinator:	Irene Rademacher
Standard:	FCC, RSS-210, EN300 328, AS/NZS 4268:2008, EN 301 489-17 V2.1.1	Class:	N/A

Test Mode Duty Cycle

Bluetooth uses a frequency hopping algorithm that means that the device, during normal operation, is only on a specific channel for a short period of time. The average correction factor is calculated as follows:

A maximum length packet has a duration of 5 time slots.

The hopping rate is 1600 hops/second so the maximum dwell time is 5/1600 seconds, or 3.125ms.

With a minimum of 20 hopping channels a channel will not be used more than 4 times in any 100ms period.

The maximum dwell time in a 100m period is $4 \times 3.125\text{ms} = 12.5\text{ms}$.

The average correction factor is, therefore, $20\log(12.5/100) = -18\text{dB}$

As this is a hopping radio the correction factor can be applied to the average value of the signal provided the average value was measured with the device continuously transmitting. DA 00-0705 permits the use of the average correction on the measured average value for frequency hopping radios.



EMC Test Data

Client: Griffin Technologies	Job Number: J92951
Model: MASM-02199 Bluetooth module (BC5)	T-Log Number: T92958
	Project Manager: Sheareen Jacobs
Contact: Michael O'Connor	Project Coordinator: Irene Rademacher
Standard: FCC, RSS-210, EN300 328, AS/NZS 4268:2008, EN 301 489-17 V2.1.1	Class: N/A

Run #1: Radiated Spurious Emissions, 1000 - 11,000 MHz. Operating Mode: basic (15/339)

Date of Test: 7/19/2013
 Test Engineer: John Caizzi
 Test Location: Chamber 5

Run #1a: Low Channel @ 2402 MHz

Band Edge Signal Field Strength - Direct measurement of field strength

Frequency MHz	Level dB μ V/m	Pol v/h	15.209 / 15.247		Detector Pk/QP/Avg	Azimuth degrees	Height meters	Comments
			Limit	Margin				
2376.050	42.6	H	54.0	-11.4	AVG	46	1.17	Note 3
2376.530	48.2	H	74.0	-25.8	PK	46	1.17	
2376.050	37.3	V	54.0	-16.7	AVG	117	2.19	Note 3
2358.900	45.8	V	74.0	-28.2	PK	117	2.19	

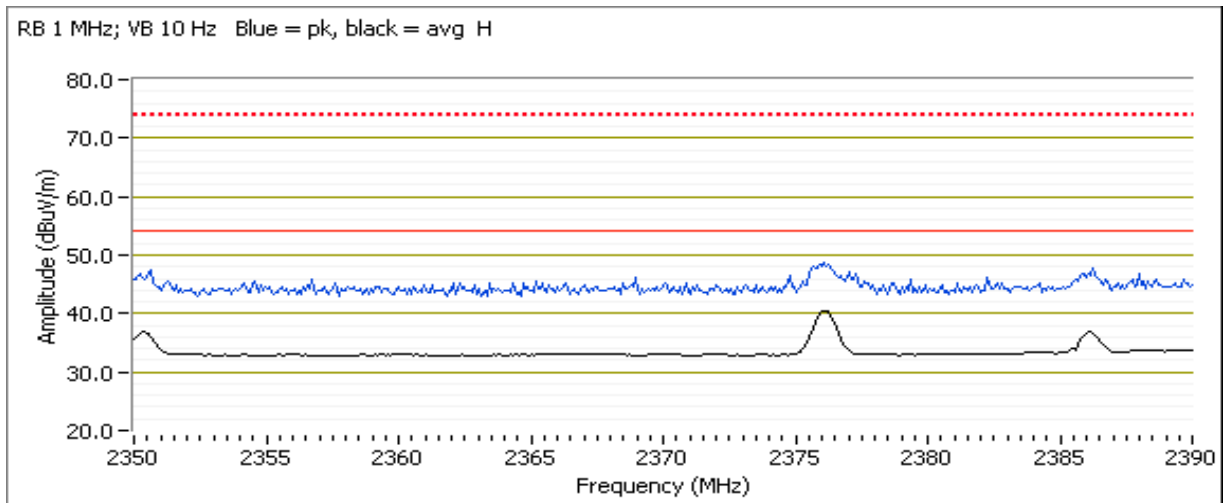

Other Spurious Emissions

Frequency MHz	Level dB μ V/m	Pol v/h	15.209 / 15.247		Detector Pk/QP/Avg	Azimuth degrees	Height meters	Comments
			Limit	Margin				
4804.080	45.9	V	54.0	-8.1	AVG	338	1.0	Notes 3 & 7
1602.100	43.0	H	54.0	-11.0	AVG	312	1.2	Note 7
4804.220	65.2	V	74.0	-8.8	PK	338	1.0	RB 1 MHz;VB 3 MHz;Peak
1602.090	61.6	H	74.0	-12.4	PK	312	1.2	RB 1 MHz;VB 3 MHz;Peak



EMC Test Data

Client: Griffin Technologies	Job Number: J92951
Model: MASM-02199 Bluetooth module (BC5)	T-Log Number: T92958
	Project Manager: Sheareen Jacobs
Contact: Michael O'Connor	Project Coordinator: Irene Rademacher
Standard: FCC, RSS-210, EN300 328, AS/NZS 4268:2008, EN 301 489-17 V2.1.1	Class: N/A

Run #1b: Center Channel @ 2441 MHz

Fundamental emission level @ 3m in 100kHz RBW:	100.1	dB μ V/m
Limit for emissions outside of restricted bands:	80.1	dB μ V/m

Limit is -20dBc (Peak power measurement)

Spurious Emissions

Frequency	Level	Pol	15.209 / 15.247		Detector	Azimuth	Height	Comments
MHz	dB μ V/m	v/h	Limit	Margin	Pk/QP/Avg	degrees	meters	
4882.080	42.1	V	54.0	-11.9	AVG	320	1.14	Notes 3 & 7
4881.950	62.6	V	74.0	-11.4	PK	320	1.14	
1626.500	40.2	H	54.0	-13.8	AVG	59	1.00	Notes 7
1626.450	58.5	H	74.0	-15.5	PK	59	1.00	

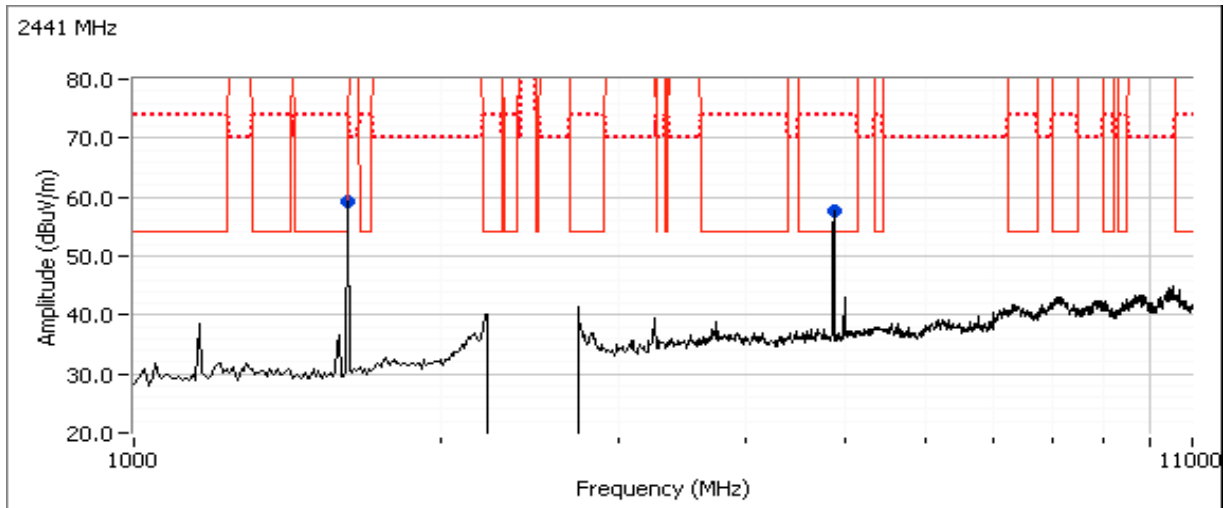



EMC Test Data

Client: Griffin Technologies	Job Number: J92951
Model: MASM-02199 Bluetooth module (BC5)	T-Log Number: T92958
	Project Manager: Sheareen Jacobs
Contact: Michael O'Connor	Project Coordinator: Irene Rademacher
Standard: FCC, RSS-210, EN300 328, AS/NZS 4268:2008, EN 301 489-17 V2.1.1	Class: N/A

Run #1c: High Channel @ 2480 MHz

Fundamental emission level @ 3m in 100kHz RBW:	98.2 dB μ V/m	Limit is -20dBc (Peak power measurement)
Limit for emissions outside of restricted bands:	78.2 dB μ V/m	

Band Edge Signal Field Strength - Direct measurement of field strength

Frequency	Level	Pol	15.209 / 15.247		Detector	Azimuth	Height	Comments
MHz	dB μ V/m	v/h	Limit	Margin	Pk/QP/Avg	degrees	meters	
2483.500	40.4	H	54.0	-13.6	AVG	51	1.09	Note 3
2483.730	49.8	H	74.0	-24.2	PK	51	1.09	

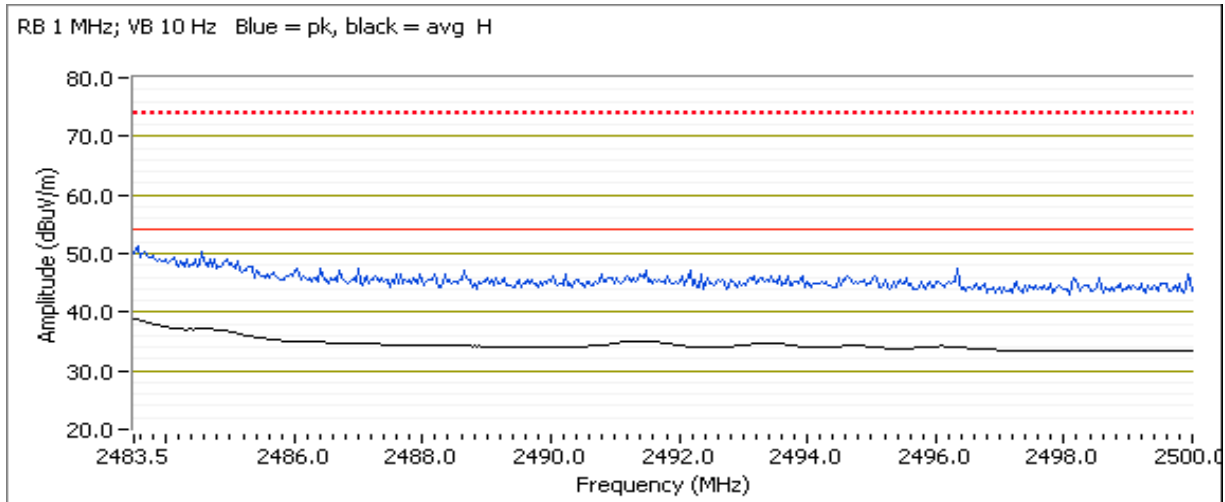

Other Spurious Emissions

Frequency	Level	Pol	15.209 / 15.247		Detector	Azimuth	Height	Comments
MHz	dB μ V/m	v/h	Limit	Margin	Pk/QP/Avg	degrees	meters	
4960.160	61.5	V	74.0	-12.5	PK	360	1.0	
4960.060	36.8	V	54.0	-17.2	AVG	360	1.0	Note 3, 7
1652.610	54.1	H	78.2	-24.1	PK	360	1.0	Note 2



EMC Test Data

Client: Griffin Technologies	Job Number: J92951
Model: MASM-02199 Bluetooth module (BC5)	T-Log Number: T92958
	Project Manager: Sheareen Jacobs
Contact: Michael O'Connor	Project Coordinator: Irene Rademacher
Standard: FCC, RSS-210, EN300 328, AS/NZS 4268:2008, EN 301 489-17 V2.1.1	Class: N/A

Run #2: Radiated Spurious Emissions, 1000 - 11,000 MHz. Operating Mode: EDR (31 / 1021)

Date of Test: 7/19/2013
 Test Engineer: John Caizzi
 Test Location: Chamber 5

Run #2a: Low Channel @ 2402 MHz

Band Edge Signal Field Strength - Direct measurement of field strength

Frequency	Level	Pol	15.209 / 15.247		Detector	Azimuth	Height	Comments
MHz	dB μ V/m	v/h	Limit	Margin	Pk/QP/Avg	degrees	meters	
2376.130	38.5	H	54.0	-15.5	AVG	55	1.14	Note 3
2375.570	46.4	H	74.0	-27.6	PK	55	1.14	

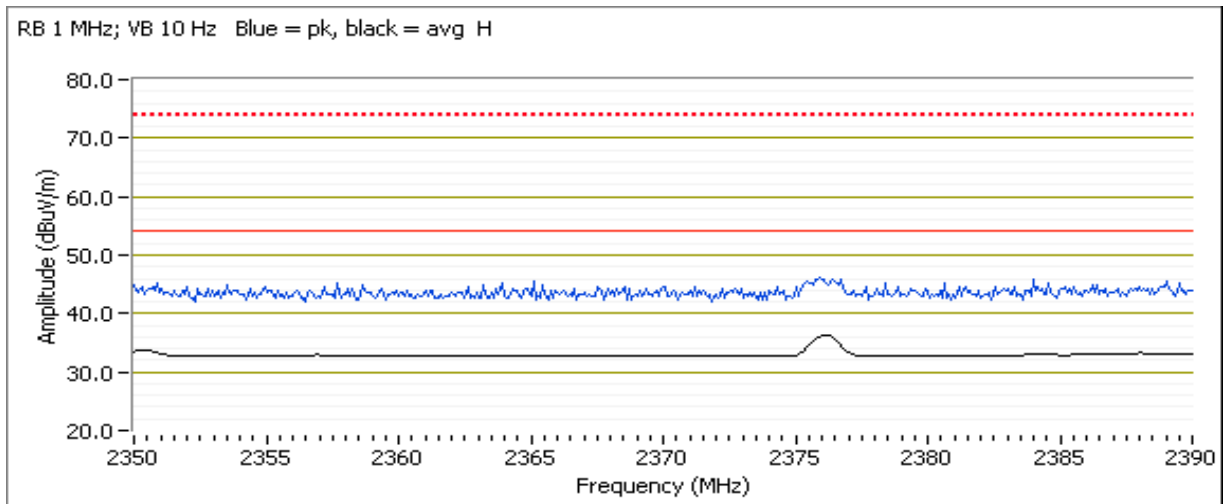

Other Spurious Emissions

Frequency	Level	Pol	15.209 / 15.247		Detector	Azimuth	Height	Comments
MHz	dB μ V/m	v/h	Limit	Margin	Pk/QP/Avg	degrees	meters	
1602.050	44.7	H	54.0	-9.3	AVG	328	1.3	Note 7
1602.040	63.2	H	74.0	-10.8	PK	328	1.3	
4803.970	61.0	V	74.0	-13.0	PK	349	1.1	
4804.050	36.2	V	54.0	-17.8	AVG	349	1.1	Note 3,7



EMC Test Data

Client: Griffin Technologies	Job Number: J92951
Model: MASM-02199 Bluetooth module (BC5)	T-Log Number: T92958
	Project Manager: Sheareen Jacobs
Contact: Michael O'Connor	Project Coordinator: Irene Rademacher
Standard: FCC, RSS-210, EN300 328, AS/NZS 4268:2008, EN 301 489-17 V2.1.1	Class: N/A

Run #2b: Center Channel @ 2441 MHz

Fundamental emission level @ 3m in 100kHz RBW:	97.3	dB μ V/m
Limit for emissions outside of restricted bands:	77.3	dB μ V/m

Limit is -20dBc (Peak power measurement)

Spurious Emissions

Frequency MHz	Level dB μ V/m	Pol v/h	15.209 / 15.247		Detector Pk/QP/Avg	Azimuth degrees	Height meters	Comments
			Limit	Margin				
1626.450	41.9	H	54.0	-12.1	AVG	328	1.2	Note 7
1626.370	60.5	H	74.0	-13.5	PK	328	1.2	
4882.090	58.7	V	74.0	-15.3	PK	236	1.1	
4882.000	31.7	V	54.0	-22.3	AVG	236	1.1	Note 3,7

Client: Griffin Technologies	Job Number: J92951
Model: MASM-02199 Bluetooth module (BC5)	T-Log Number: T92958
	Project Manager: Sheareen Jacobs
Contact: Michael O'Connor	Project Coordinator: Irene Rademacher
Standard: FCC, RSS-210, EN300 328, AS/NZS 4268:2008, EN 301 489-17 V2.1.1	Class: N/A

Run #2c: High Channel @ 2480 MHz

Fundamental emission level @ 3m in 100kHz RBW:	94.9 dB μ V/m	Limit is -20dBc (Peak power measurement)
Limit for emissions outside of restricted bands:	74.9 dB μ V/m	

Band Edge Signal Field Strength - Direct measurement of field strength

Frequency	Level	Pol	15.209 / 15.247		Detector	Azimuth	Height	Comments
MHz	dB μ V/m	v/h	Limit	Margin	Pk/QP/Avg	degrees	meters	
2483.500	39.6	H	54.0	-14.4	AVG	67	1.15	Note 3
2483.730	49.2	H	74.0	-24.8	PK	67	1.15	

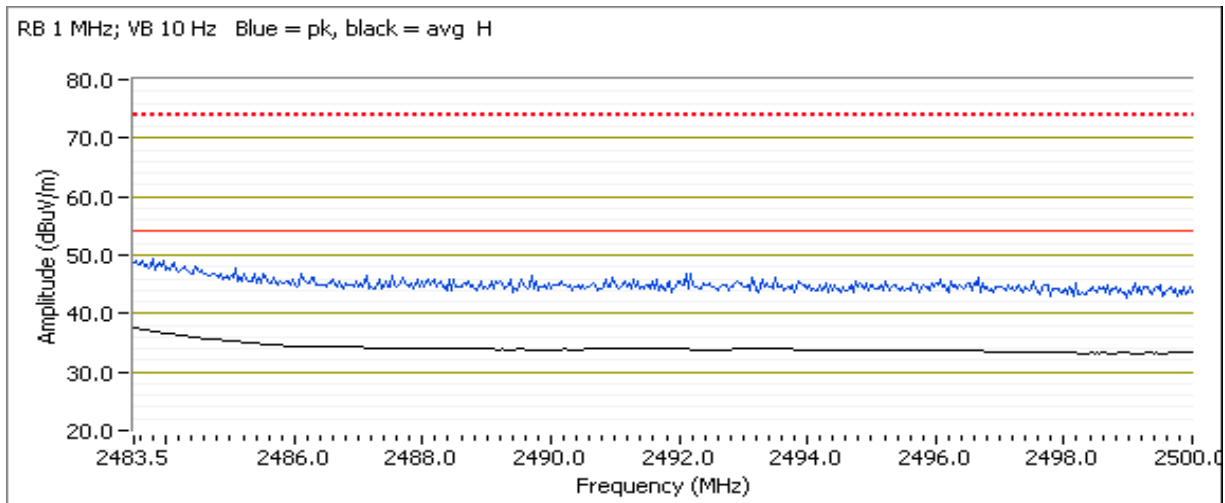

Other Spurious Emissions

Frequency	Level	Pol	15.209 / 15.247		Detector	Azimuth	Height	Comments
MHz	dB μ V/m	v/h	Limit	Margin	Pk/QP/Avg	degrees	meters	
4960.000	57.1	V	74.0	-16.9	PK	240	1.1	
1652.880	54.4	H	74.9	-20.5	PK	356	1.0	Note 2
4960.020	27.0	V	54.0	-27.0	AVG	240	1.1	Note 3, 7



EMC Test Data

Client: Griffin Technologies	Job Number: J92951
Model: MASM-02199 Bluetooth module (BC5)	T-Log Number: T92958
	Project Manager: Sheareen Jacobs
Contact: Michael O'Connor	Project Coordinator: Irene Rademacher
Standard: FCC, RSS-210, EN300 328, AS/NZS 4268:2008, EN 301 489-17 V2.1.1	Class: N/A

FCC 15.247 FHSS - Power, Bandwidth and Spurious Emissions

Test Specific Details

Objective: The objective of this test session is to perform final qualification testing of the EUT with respect to the specification listed above.

Date of Test: 7/17/2013 1:48
 Test Engineer: Rafael Varelas
 Test Location: Fremont Chamber #7

Config. Used: New Sample
 Config Change: New Sample
 EUT Voltage: 5Vdc

General Test Configuration

The EUT and all local support equipment were located on the turntable for radiated spurious emissions testing.

For radiated emissions testing the measurement antenna was located 3 meters from the EUT.

When measuring the conducted emissions from the EUT's antenna port, the antenna port of the EUT was connected to the spectrum analyzer or power meter via a suitable attenuator to prevent overloading the measurement system. All measurements are corrected to allow for the external attenuators used.

Unless stated otherwise the EUT was operating such that it constantly hopped on either the low, center or high channels.

Ambient Conditions:

Temperature: 21.4 °C
 Rel. Humidity: 38 %

Summary of Results

Run #	Test Performed	Limit	Pass / Fail	Result / Margin
1-2	Fundamental Field Strength	FCC Part 15.209 / 15.247(c)	-	-

Modifications Made During Testing:

No modifications were made to the EUT during testing

Deviations From The Standard

No deviations were made from the requirements of the standard.



EMC Test Data

Client: Griffin Technologies	Job Number: J92951
Model: MASM-02199 Bluetooth module (BC5)	T-Log Number: T92958
	Project Manager: Sheareen Jacobs
Contact: Michael O'Connor	Project Coordinator: Irene Rademacher
Standard: FCC, RSS-210, EN300 328, AS/NZS 4268:2008, EN 301 489-17 V2.1.1	Class: N/A

Run #1: Radiated Spurious Emissions. Basic: type = 15, size = 339

Power Setting = 255 Ext, 63 Int.

Date of Test: 7/17/2013

Test Engineer: Rafael Varelas

Test Location: FT Chamber #7

Run #1a: Radiated Spurious Emissions. Low Channel @ 2402 MHz

Fundamental Signal Field Strength: Peak and average values measured in 1 MHz, and peak value measured in 100kHz

Frequency MHz	Level dB μ V/m	Pol v/h	15.209 / 15.247		Detector Pk/QP/Avg	Azimuth degrees	Height meters	Comments
			Limit	Margin				
2402.090	100.0	H	-	-	AVG	307	1.2	POS; RB 1 MHz; VB: 10 Hz
2402.220	102.6	H	-	-	PK	307	1.2	POS; RB 1 MHz; VB: 3 MHz
2402.020	101.3	H	-	-	PK	307	1.2	POS; RB 100 kHz; VB: 100 kHz
2402.090	93.4	V	-	-	AVG	44	1.8	POS; RB 1 MHz; VB: 10 Hz
2402.200	96.0	V	-	-	PK	44	1.8	POS; RB 1 MHz; VB: 3 MHz
2402.020	95.6	V	-	-	PK	44	1.8	POS; RB 100 kHz; VB: 100 kHz

Fundamental emission level @ 3m in 100kHz RBW: 101.3

Limit for emissions outside of restricted bands: 81.3 dB μ V/m Limit is -20dBc

Run #1b: Radiated Spurious Emissions. Center Channel @ 2441 MHz

Fundamental Signal Field Strength: Peak and average values measured in 1 MHz, and peak value measured in 100kHz

Frequency MHz	Level dB μ V/m	Pol v/h	15.209 / 15.247		Detector Pk/QP/Avg	Azimuth degrees	Height meters	Comments
			Limit	Margin				
2441.080	98.1	H	-	-	AVG	356	1.2	POS; RB 1 MHz; VB: 10 Hz
2440.850	100.7	H	-	-	PK	356	1.2	POS; RB 1 MHz; VB: 3 MHz
2441.000	100.1	H	-	-	PK	356	1.2	POS; RB 100 kHz; VB: 100 kHz
2441.090	91.2	V	-	-	AVG	43	1.8	POS; RB 1 MHz; VB: 10 Hz
2440.860	93.8	V	-	-	PK	43	1.8	POS; RB 1 MHz; VB: 3 MHz
2441.170	93.6	V	-	-	PK	43	1.8	POS; RB 100 kHz; VB: 100 kHz

Fundamental emission level @ 3m in 100kHz RBW: 100.1

Limit for emissions outside of restricted bands: 80.1 dB μ V/m



EMC Test Data

Client: Griffin Technologies	Job Number: J92951
Model: MASM-02199 Bluetooth module (BC5)	T-Log Number: T92958
	Project Manager: Sheareen Jacobs
Contact: Michael O'Connor	Project Coordinator: Irene Rademacher
Standard: FCC, RSS-210, EN300 328, AS/NZS 4268:2008, EN 301 489-17 V2.1.1	Class: N/A

Run #1c: Radiated Spurious Emissions. High Channel @ 2480 MHz

Fundamental Signal Field Strength: Peak and average values measured in 1 MHz, and peak value measured in 100kHz

Frequency	Level	Pol	15.209 / 15.247		Detector	Azimuth	Height	Comments
MHz	dB μ V/m	v/h	Limit	Margin	Pk/QP/Avg	degrees	meters	
2480.080	95.8	H	-	-	AVG	350	1.1	POS; RB 1 MHz; VB: 10 Hz
2479.800	98.5	H	-	-	PK	350	1.1	POS; RB 1 MHz; VB: 3 MHz
2480.000	98.2	H	-	-	PK	350	1.1	POS; RB 100 kHz; VB: 100 kHz
2480.080	87.0	V	-	-	AVG	43	2.1	POS; RB 1 MHz; VB: 10 Hz
2479.850	89.7	V	-	-	PK	43	2.1	POS; RB 1 MHz; VB: 3 MHz
2480.050	89.2	V	-	-	PK	43	2.1	POS; RB 100 kHz; VB: 100 kHz

Fundamental emission level @ 3m in 100kHz RBW:	98.2	
Limit for emissions outside of restricted bands:	78.2 dB μ V/m	Limit is -20dBc

Run #2: Radiated Spurious Emissions. EDR: type = 31, size = 1021

Power Setting = 255 Ext, 63 Int.

Date of Test: 7/17/2013

Test Engineer: Rafael Varelas

Test Location: FT Chamber #7

Run #1a: Radiated Spurious Emissions. Low Channel @ 2402 MHz

Fundamental Signal Field Strength: Peak and average values measured in 1 MHz, and peak value measured in 100kHz

Frequency	Level	Pol	15.209 / 15.247		Detector	Azimuth	Height	Comments
MHz	dB μ V/m	v/h	Limit	Margin	Pk/QP/Avg	degrees	meters	
2402.110	94.9	H	-	-	AVG	308	1.1	POS; RB 1 MHz; VB: 10 Hz
2401.800	100.2	H	-	-	PK	308	1.1	POS; RB 1 MHz; VB: 3 MHz
2402.140	100.1	H	-	-	PK	308	1.1	POS; RB 100 kHz; VB: 100 kHz
2402.080	80.3	V	-	-	AVG	338	1.8	POS; RB 1 MHz; VB: 10 Hz
2401.990	85.9	V	-	-	PK	338	1.8	POS; RB 1 MHz; VB: 3 MHz
2401.830	84.9	V	-	-	PK	338	1.8	POS; RB 100 kHz; VB: 100 kHz

Fundamental emission level @ 3m in 100kHz RBW:	100.1	
Limit for emissions outside of restricted bands:	80.1 dB μ V/m	Limit is -20dBc



EMC Test Data

Client: Griffin Technologies	Job Number: J92951
Model: MASM-02199 Bluetooth module (BC5)	T-Log Number: T92958
	Project Manager: Sheareen Jacobs
Contact: Michael O'Connor	Project Coordinator: Irene Rademacher
Standard: FCC, RSS-210, EN300 328, AS/NZS 4268:2008, EN 301 489-17 V2.1.1	Class: N/A

Run #2b: Radiated Spurious Emissions. Center Channel @ 2441 MHz

Fundamental Signal Field Strength: Peak and average values measured in 1 MHz, and peak value measured in 100kHz

Frequency MHz	Level dB μ V/m	Pol v/h	15.209 / 15.247		Detector Pk/QP/Avg	Azimuth degrees	Height meters	Comments
			Limit	Margin				
2441.090	92.7	H	-	-	AVG	357	1.1	POS; RB 1 MHz; VB: 10 Hz
2440.970	98.3	H	-	-	PK	357	1.1	POS; RB 1 MHz; VB: 3 MHz
2440.960	97.3	H	-	-	PK	357	1.1	POS; RB 100 kHz; VB: 100 kHz
2441.080	82.5	V	-	-	AVG	358	1.1	POS; RB 1 MHz; VB: 10 Hz
2440.880	87.8	V	-	-	PK	358	1.1	POS; RB 1 MHz; VB: 3 MHz
2441.030	87.5	V	-	-	PK	358	1.1	POS; RB 100 kHz; VB: 100 kHz

Fundamental emission level @ 3m in 100kHz RBW:	97.3
Limit for emissions outside of restricted bands:	77.3 dB μ V/m

Run #3c: Radiated Spurious Emissions. High Channel @ 2480 MHz

Fundamental Signal Field Strength: Peak and average values measured in 1 MHz, and peak value measured in 100kHz

Frequency MHz	Level dB μ V/m	Pol v/h	15.209 / 15.247		Detector Pk/QP/Avg	Azimuth degrees	Height meters	Comments
			Limit	Margin				
2480.090	89.7	H	-	-	AVG	347	1.1	POS; RB 1 MHz; VB: 10 Hz
2479.860	95.3	H	-	-	PK	347	1.1	POS; RB 1 MHz; VB: 3 MHz
2480.140	94.9	H	-	-	PK	347	1.1	POS; RB 100 kHz; VB: 100 kHz
2480.060	81.0	V	-	-	AVG	42	2.1	POS; RB 1 MHz; VB: 10 Hz
2479.850	86.6	V	-	-	PK	42	2.1	POS; RB 1 MHz; VB: 3 MHz
2480.120	86.0	V	-	-	PK	42	2.1	POS; RB 100 kHz; VB: 100 kHz

Fundamental emission level @ 3m in 100kHz RBW:	94.9
Limit for emissions outside of restricted bands:	74.9 dB μ V/m

Limit is -20dBc



EMC Test Data

Client:	Griffin Technologies	Job Number:	J92951
Model:	MASM-02199 Bluetooth module (BC5)	T-Log Number:	T92958
		Project Manager:	Sheareen Jacobs
Contact:	Michael O'Connor	Project Coordinator:	Irene Rademacher
Standard:	FCC, RSS-210, EN300 328, AS/NZS 4268:2008, EN 301 489-17 V2.1.1	Class:	N/A

FCC 15.247 FHSS - Power, Bandwidth and Spurious Emissions

Test Specific Details

Objective: The objective of this test session is to perform final qualification testing of the EUT with respect to the specification listed above.

Date of Test: 7/15/2013 1:01
 Test Engineer: Rafael Varelas
 Test Location: Fremont Chamber #7

Config. Used: 1
 Config Change: None
 EUT Voltage: 5Vdc

General Test Configuration

When measuring the conducted emissions from the EUT's antenna port, the antenna port of the EUT was connected to the spectrum analyzer or power meter via a suitable attenuator to prevent overloading the measurement system. All measurements are corrected to allow for the external attenuators used.

Unless stated otherwise the EUT was operating such that it constantly hopped on either the low, center or high channels.

Ambient Conditions:

Temperature: 21.4 °C
 Rel. Humidity: 38 %

Summary of Results

Run #	Test Performed	Limit	Pass / Fail	Result / Margin
1	30 - 25,000 MHz - Transmitter Conducted Spurious Emissions	FCC Part 15.247(c)	Pass	All emissions more than 20dB below the highest in-band signal level.
2	Output Power	15.247(b)	Pass	Basic: 3.3 dBm (0.002 W) EDR: 1.9 dBm (0.002 W)
3	20dB Bandwidth	15.247(a)	Pass	Basic: 920 kHz EDR: 1269 kHz
3	99% bandwidth	15.247(a)	Pass	Basic: 876 kHz EDR: 1170 kHz
3	Channel Spacing	15.247(a)	Pass	1 MHz
3	Channel Occupancy	15.247(a)	Pass	79 Channels
3	Number of Channels	15.247(a)	Pass	

Modifications Made During Testing:

No modifications were made to the EUT during testing

Deviations From The Standard

No deviations were made from the requirements of the standard.

Client: Griffin Technologies	Job Number: J92951
Model: MASM-02199 Bluetooth module (BC5)	T-Log Number: T92958
	Project Manager: Sheareen Jacobs
Contact: Michael O'Connor	Project Coordinator: Irene Rademacher
Standard: FCC, RSS-210, EN300 328, AS/NZS 4268:2008, EN 301 489-17 V2.1.1	Class: N/A

Run #1: Antenna Conducted Spurious Emissions, 30 - 25,000 MHz.

Date of Test: 7/15/2013

Test Engineer: Rafael Varelas

Test Location: FT Chamber #7

Refer to plots below. Scans made using RBW=VB=100 KHz with the limit line set at 20dB below the highest in-band signal level with the hopping feature disabled.

Basic Mode

Low channel

Plot showing -20dBc at the lower band edge

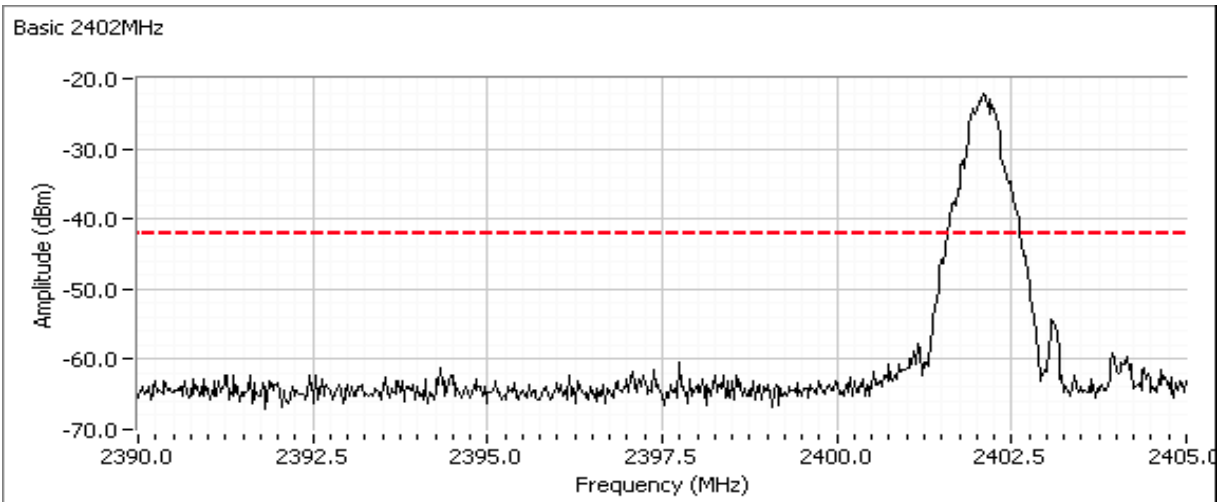

Client: Griffin Technologies	Job Number: J92951
Model: MASM-02199 Bluetooth module (BC5)	T-Log Number: T92958
	Project Manager: Sheareen Jacobs
Contact: Michael O'Connor	Project Coordinator: Irene Rademacher
Standard: FCC, RSS-210, EN300 328, AS/NZS 4268:2008, EN 301 489-17 V2.1.1	Class: N/A

High channel

Plot showing -20dBc at the upper band edge

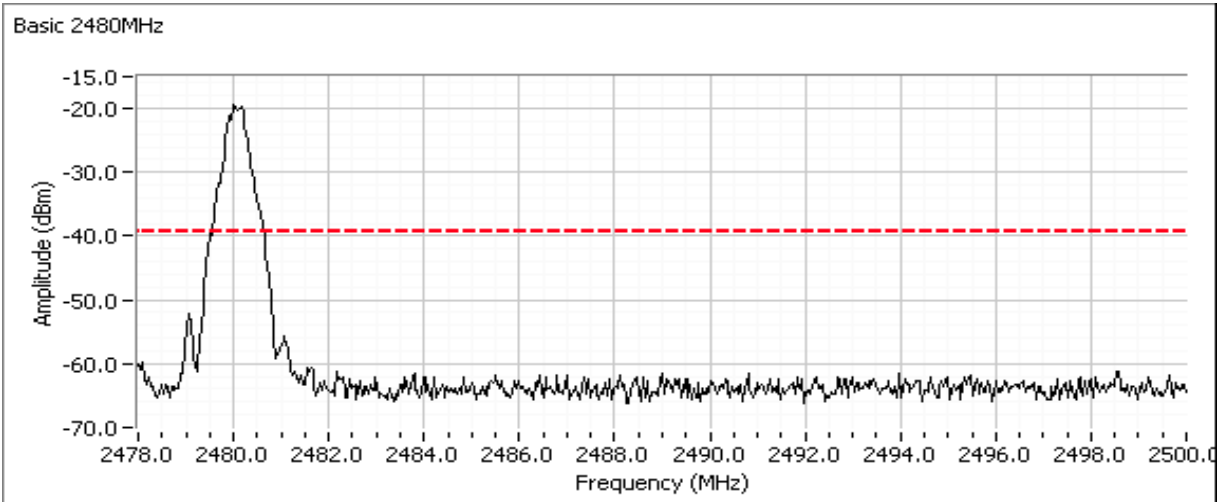

Client: Griffin Technologies	Job Number: J92951
Model: MASM-02199 Bluetooth module (BC5)	T-Log Number: T92958
	Project Manager: Sheareen Jacobs
Contact: Michael O'Connor	Project Coordinator: Irene Rademacher
Standard: FCC, RSS-210, EN300 328, AS/NZS 4268:2008, EN 301 489-17 V2.1.1	Class: N/A

Refer to plots below. Scans made using RBW=VB=100 KHz with the limit line set at 20dB below the highest in-band signal level with the hopping feature enabled to show compliance with the -20dBc requirement at the allocated band edge. The spectrum analyzer is left in max hold mode until the trace stabilizes.

Low channel, hopping enabled
Plot showing -20dBc at the lower band edge

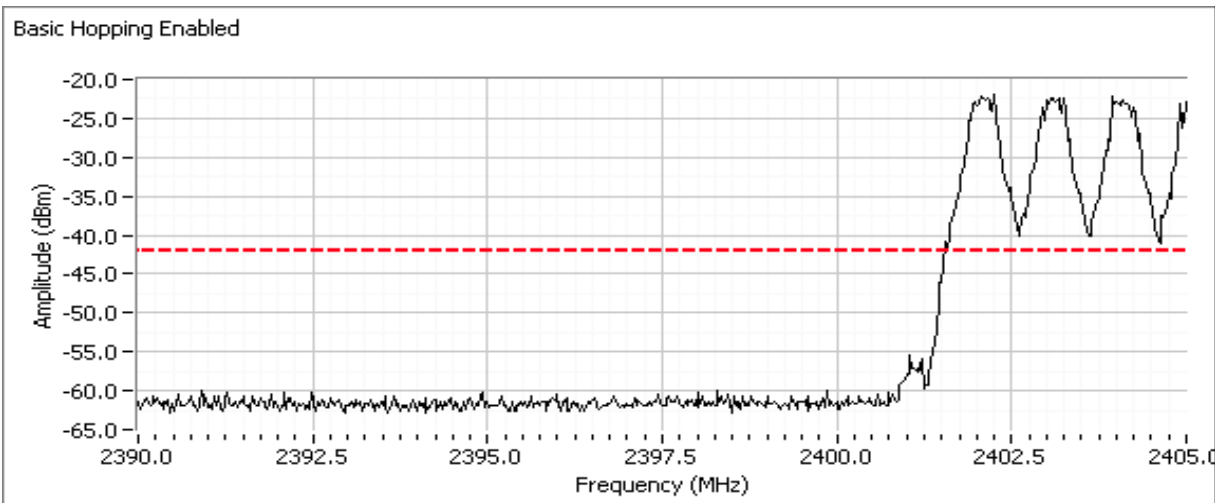

High channel, hopping enabled
Plot showing -20dBc at the upper band edge

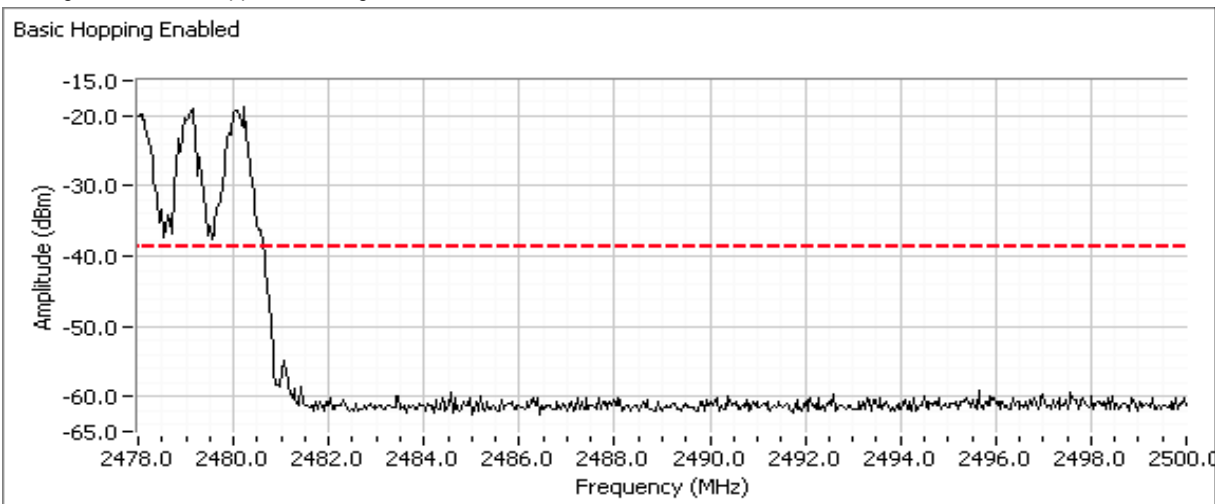

Client: Griffin Technologies	Job Number: J92951
Model: MASM-02199 Bluetooth module (BC5)	T-Log Number: T92958
	Project Manager: Sheareen Jacobs
Contact: Michael O'Connor	Project Coordinator: Irene Rademacher
Standard: FCC, RSS-210, EN300 328, AS/NZS 4268:2008, EN 301 489-17 V2.1.1	Class: N/A

EDR Mode

Low channel

Plot showing -20dBc at the lower band edge

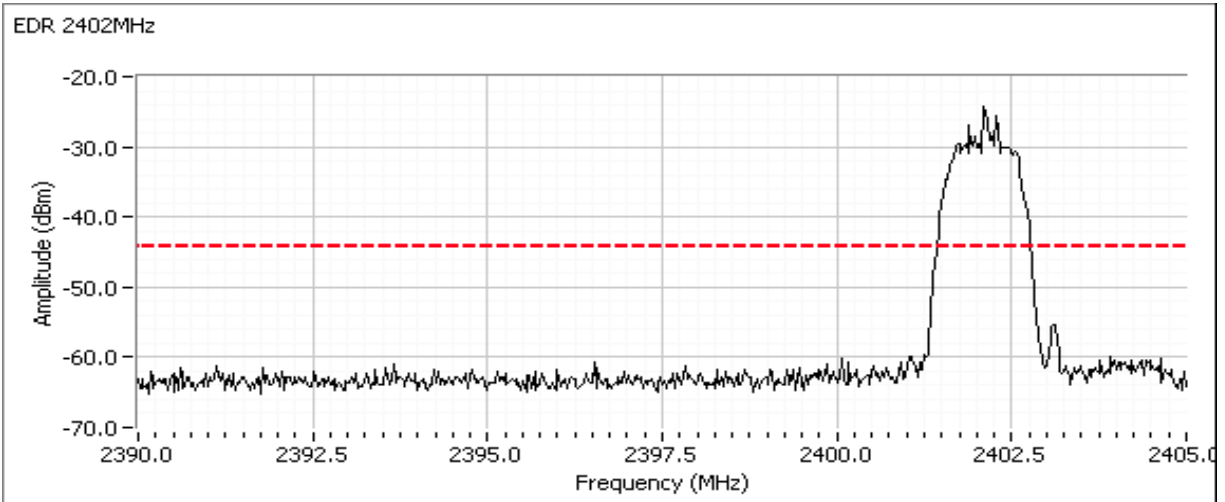

High channel

Broadband plot

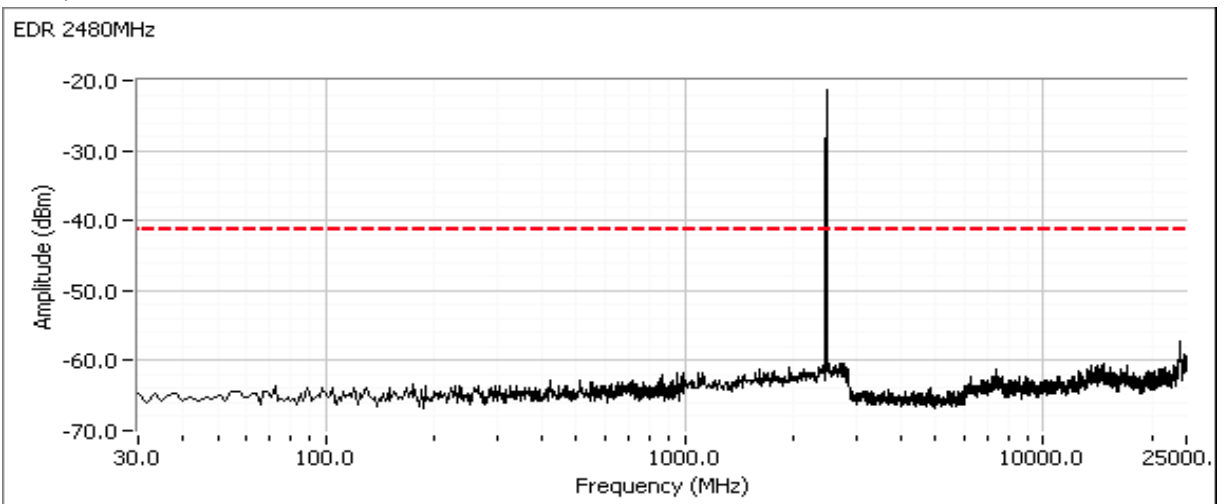

Client: Griffin Technologies	Job Number: J92951
Model: MASM-02199 Bluetooth module (BC5)	T-Log Number: T92958
	Project Manager: Sheareen Jacobs
Contact: Michael O'Connor	Project Coordinator: Irene Rademacher
Standard: FCC, RSS-210, EN300 328, AS/NZS 4268:2008, EN 301 489-17 V2.1.1	Class: N/A

Plot showing -20dBc at the upper band edge

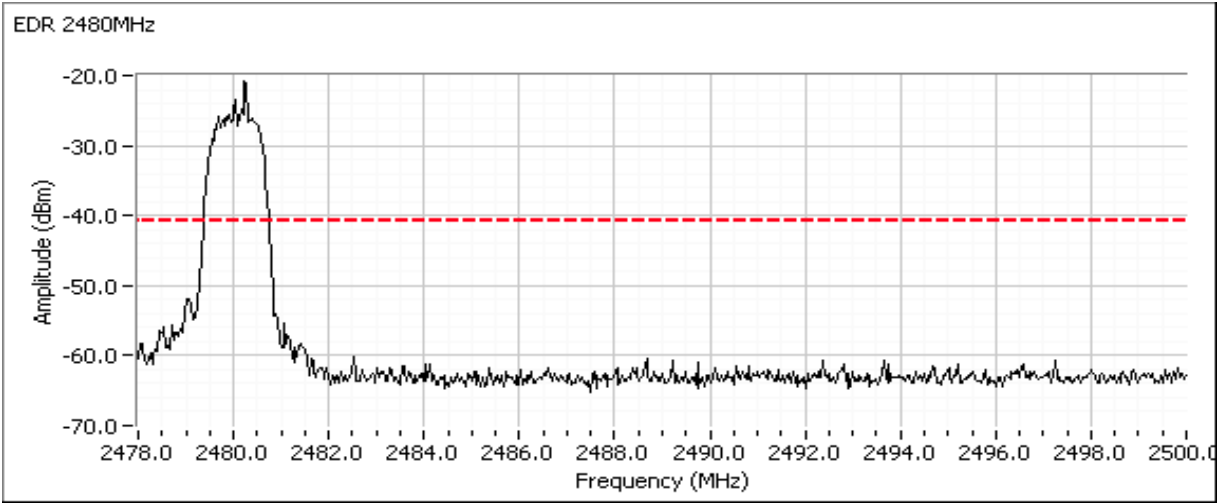

Refer to plots below. Scans made using RBW=VB=100 KHz with the limit line set at 20dB below the highest in-band signal level with the hopping feature enabled to show compliance with the -20dBc requirement at the allocated band edge. The spectrum analyzer is left in max hold mode until the trace stabilizes.

Low channel, hopping enabled

Plot showing -20dBc at the lower band edge

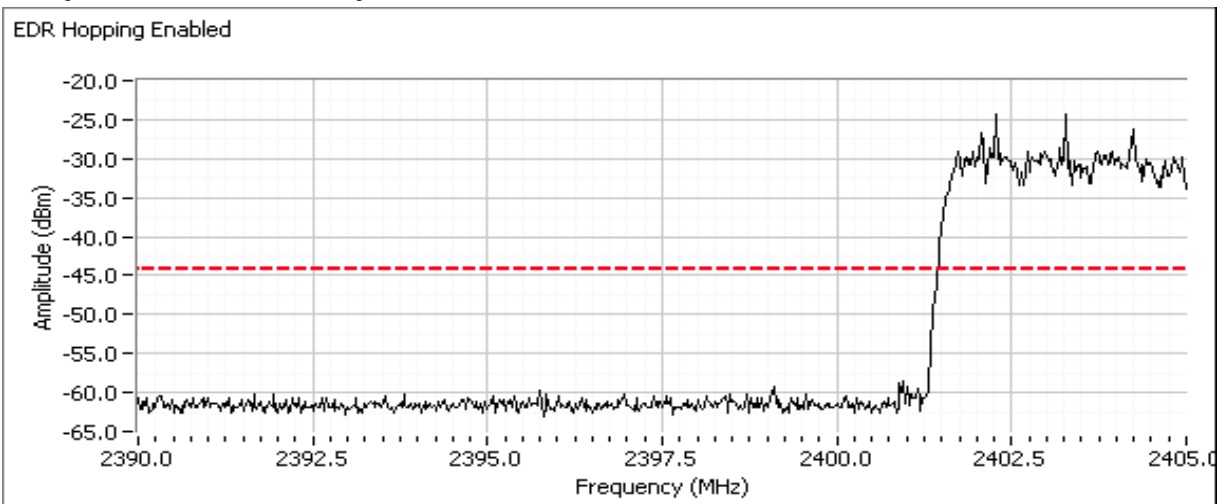

Client: Griffin Technologies	Job Number: J92951
Model: MASM-02199 Bluetooth module (BC5)	T-Log Number: T92958
	Project Manager: Sheareen Jacobs
Contact: Michael O'Connor	Project Coordinator: Irene Rademacher
Standard: FCC, RSS-210, EN300 328, AS/NZS 4268:2008, EN 301 489-17 V2.1.1	Class: N/A

High channel, hopping enabled
 Plot showing -20dBc at the upper band edge

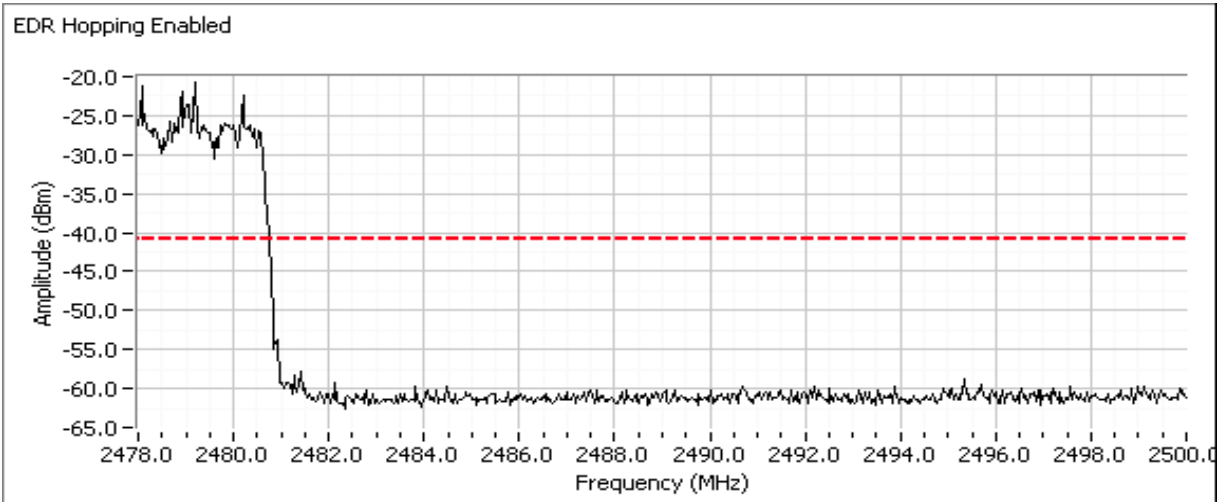



EMC Test Data

Client: Griffin Technologies	Job Number: J92951
Model: MASM-02199 Bluetooth module (BC5)	T-Log Number: T92958
	Project Manager: Sheareen Jacobs
Contact: Michael O'Connor	Project Coordinator: Irene Rademacher
Standard: FCC, RSS-210, EN300 328, AS/NZS 4268:2008, EN 301 489-17 V2.1.1	Class: N/A

Run #2: Output Power

Date of Test: See RE See
 Test Engineer: See RE See
 Test Location: See RE See

For frequency hopping systems operating in the 2400-2483.5 MHz band employing at least 75 non-overlapping hopping channels, and all frequency hopping systems in the 5725-5850 MHz band: 1 watt.

For all other frequency hopping systems in the 2400-2483.5 MHz band: 0.125 watts.

Channel	Frequency (MHz)	Field Strength at 3m (dBuV/m)	Antenna Pol. (H/V)	Res BW (MHz)	Signal Bandwidth	Bandwidth Correction	Power eirp (dBm)	Power (Watts)
Basic Mode								
Low	2402	102.6	H	1.0	0.876	0	7.3	0.00537
Mid	2441	100.7	H	1.0	0.876	0	5.4	0.00347
High	2480	98.5	H	1.0	0.876	0	3.2	0.00209
EDR Mode								
Low	2402	100.2	H	1.0	1.269	1.03462	5.9	0.00392
Mid	2441	98.3	H	1.0	1.269	1.03462	4.0	0.00253
High	2480	95.3	H	1.0	1.263	1.01403	1.0	0.00126

Note 1: Output power calculated from field strength at 3m based on free space path loss formula $E = \sqrt{(30PG) / d}$, where E is the field strength (V/m), PG is the effective isotropic radiated power (W) and d is the distance (3m). Additional correction to the calculated power is made to account for the difference between the measurement bandwidth and signal bandwidth.

Channel	Frequency (MHz)	Power eirp (dBm)	Antenna Gain	Conducted Power (dBm)	Power (Watts)
Basic Mode					
Low	2402	7.3	4.0	3.3	0.002
Mid	2441	5.4	4.0	1.4	0.001
High	2480	3.2	4.0	-0.8	0.001
EDR Mode					
Low	2402	5.9	4.0	1.9	0.002
Mid	2441	4.0	4.0	0.0	0.001
High	2480	1.0	4.0	-3.0	0.001



EMC Test Data

Client: Griffin Technologies	Job Number: J92951
Model: MASM-02199 Bluetooth module (BC5)	T-Log Number: T92958
	Project Manager: Sheareen Jacobs
Contact: Michael O'Connor	Project Coordinator: Irene Rademacher
Standard: FCC, RSS-210, EN300 328, AS/NZS 4268:2008, EN 301 489-17 V2.1.1	Class: N/A

Run #3: Bandwidth, Channel Occupancy, Spacing and Number of Channels

Date of Test: 29-Jul-13

Test Engineer: Deniz Demirci

Test Location: FT Ch# 4

Basic

Channel	Frequency (MHz)	Resolution Bandwidth	20dB Bandwidth (kHz)	Resolution Bandwidth	99% Bandwidth (kHz)
Low	2402	10 kHz	920	30 kHz	876
Mid	2441	10 kHz	920	30 kHz	876
High	2480	10 kHz	920	30 kHz	876

EDR

Channel	Frequency (MHz)	Resolution Bandwidth	20dB Bandwidth (kHz)	Resolution Bandwidth	99% Bandwidth (kHz)
Low	2402	30 kHz	1269	30 kHz	1170
Mid	2441	30 kHz	1269	30 kHz	1170
High	2480	30 kHz	1263	30 kHz	1170

Note 1: For Basic mode, 20dB bandwidth measured using RB = 10 kHz, VB = 30 kHz (VB > RB)

Note 2: For EDR mode, 20dB bandwidth measured using RB = 30 kHz, VB = 100 kHz (VB > RB)

Note 3: 99% bandwidth measured using RB = 30 kHz, VB = 100 kHz (VB >=3RB)

Client: Griffin Technologies	Job Number: J92951
Model: MASM-02199 Bluetooth module (BC5)	T-Log Number: T92958
Contact: Michael O'Connor	Project Manager: Sheareen Jacobs
Standard: FCC, RSS-210, EN300 328, AS/NZS 4268:2008, EN 301 489-17 V2.1.1	Project Coordinator: Irene Rademacher
	Class: N/A

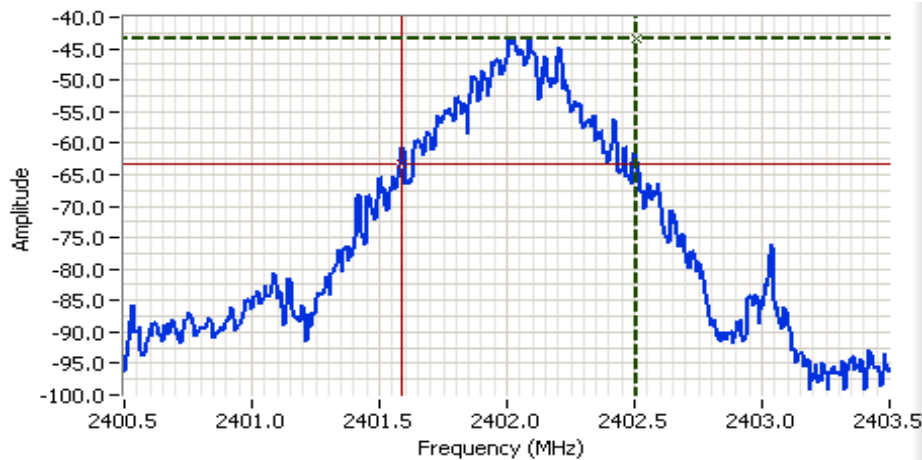

Analyzer Settings
 Rohde&Schwarz,ESI
 CF: 2402.000 MHz
 SPAN: 3.000 MHz
 RB: 10.0 kHz
 VB: 30.0 kHz
 Detector: POS
 Attn: 0 DB
 RL Offset: 0.0 DB
 Sweep Time: 76.0ms
 Ref Lvl: -35.0 DBM

Comments
 20dB BW: 920 kHz
 Basic

Cursor 1 2402.5080 -43.28

Cursor 2 2401.5882 -63.28

Delta Freq. 920 kHz

Delta Amplitude 20.00

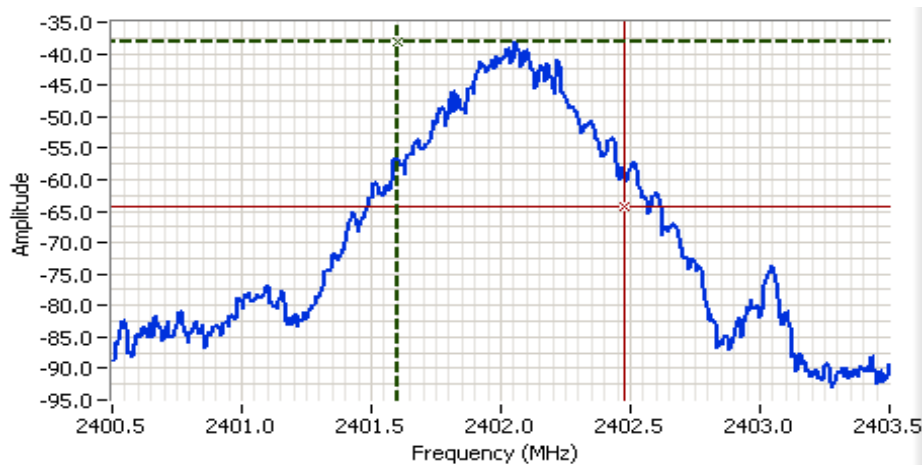

Analyzer Settings
 Rohde&Schwarz,ESI
 CF: 2402.000 MHz
 SPAN: 3.000 MHz
 RB: 30.0 kHz
 VB: 100 kHz
 Detector: POS
 Attn: 0 DB
 RL Offset: 0.0 DB
 Sweep Time: 8.5ms
 Ref Lvl: -35.0 DBM

Comments
 99% power BW: 876 kHz
 Basic

Cursor 1 2401.6040 -38.18

Cursor 2 2402.4800 -64.18

Delta Freq. 876 kHz

Delta Amplitude 26.00





EMC Test Data

Client: Griffin Technologies	Job Number: J92951
Model: MASM-02199 Bluetooth module (BC5)	T-Log Number: T92958
Contact: Michael O'Connor	Project Manager: Sheareen Jacobs
Standard: FCC, RSS-210, EN300 328, AS/NZS 4268:2008, EN 301 489-17 V2.1.1	Project Coordinator: Irene Rademacher
	Class: N/A

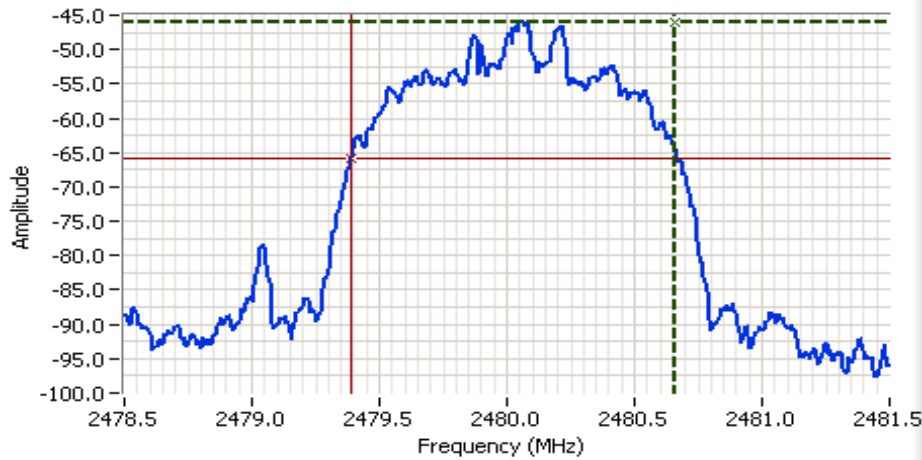

Analyzer Settings

Rohde&Schwarz,ESI
 CF: 2480.000 MHz
 SPAN: 3.000 MHz
 RB: 30.0 kHz
 VB: 100 kHz
 Detector: POS
 Attn: 0 DB
 RL Offset: 0.0 DB
 Sweep Time: 8.5ms
 Ref Lvl: -35.0 DBM

Comments

20dB BW: 1.269 MHz
 EDR

Cursor 1	2480.6583	-45.91	
Cursor 2	2479.3898	-65.91	

Delta Freq. 1.269
 Delta Amplitude 20.00

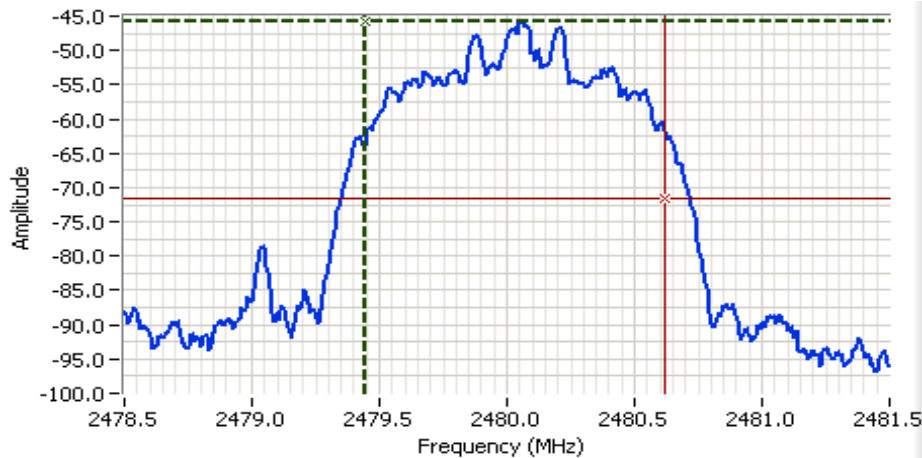

Analyzer Settings

Rohde&Schwarz,ESI
 CF: 2480.000 MHz
 SPAN: 3.000 MHz
 RB: 30.0 kHz
 VB: 100 kHz
 Detector: POS
 Attn: 0 DB
 RL Offset: 0.0 DB
 Sweep Time: 8.5ms
 Ref Lvl: -35.0 DBM

Comments

99% power BW: 1.170 MHz
 EDR

Cursor 1	2479.4480	-45.67	
Cursor 2	2480.6180	-71.67	

Delta Freq. 1.170
 Delta Amplitude 26.00





EMC Test Data

Client: Griffin Technologies	Job Number: J92951
Model: MASM-02199 Bluetooth module (BC5)	T-Log Number: T92958
	Project Manager: Sheareen Jacobs
Contact: Michael O'Connor	Project Coordinator: Irene Rademacher
Standard: FCC, RSS-210, EN300 328, AS/NZS 4268:2008, EN 301 489-17 V2.1.1	Class: N/A

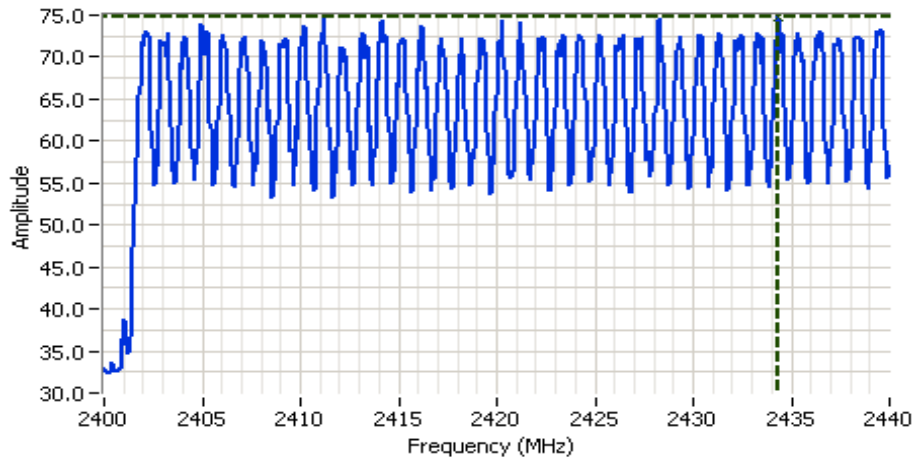

Analyzer Settings
 HP8564E,EMICF: 2420.000 MHz
 SPAN: 40.000 MHz
 RB: 30.0 kHz
 VB: 100 kHz
 Detector: POS
 Attn: 10 DB
 RL Offset: 0.0 DB
 Sweep Time: 120.0ms
 Ref Lvl: 105.0 DBUV

Comments
 Number of Channels: 38

Cursor 1 2434.3333 74.83

0.0000 0.00

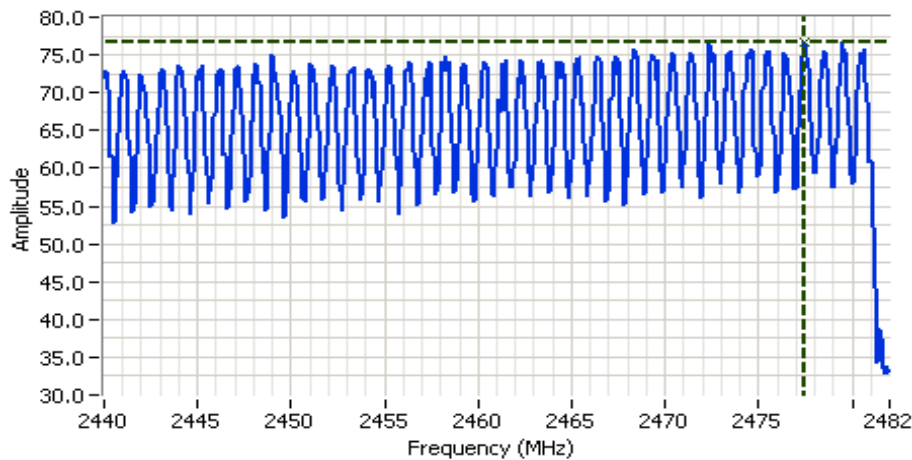

Analyzer Settings
 HP8564E,EMICF: 2461.000 MHz
 SPAN: 42.000 MHz
 RB: 30.0 kHz
 VB: 100 kHz
 Detector: POS
 Attn: 10 DB
 RL Offset: 0.0 DB
 Sweep Time: 120.0ms
 Ref Lvl: 105.0 DBUV

Comments
 Number of Channels: 41

Cursor 1 2477.4500 76.67

0.0000 0.00





EMC Test Data

Client: Griffin Technologies	Job Number: J92951
Model: MASM-02199 Bluetooth module (BC5)	T-Log Number: T92958
	Project Manager: Sheareen Jacobs
Contact: Michael O'Connor	Project Coordinator: Irene Rademacher
Standard: FCC, RSS-210, EN300 328, AS/NZS 4268:2008, EN 301 489-17 V2.1.1	Class: N/A

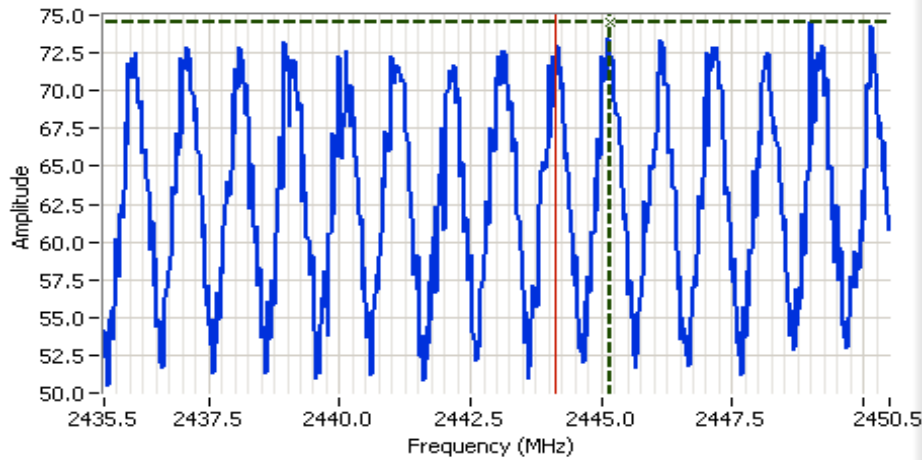

Analyzer Settings
HP8564E,EMICF: 2443.000 MHz
SPAN: 15.000 MHz
RB: 30.0 kHz
VB: 100 kHz
Detector: POS
Attn: 10 DB
RL Offset: 0.0 DB
Sweep Time: 50.0ms
Ref Lvl: 105.0 DBUV

Comments
Channel Spacing

Cursor 1	2445.1649	74.50		Delta Freq.	1.044
Cursor 1	2444.1211	0.00		Delta Amplitude	74.50





EMC Test Data

Client: Griffin Technologies	Job Number: J92951
Model: MASM-02199 Bluetooth module (BC5)	T-Log Number: T92958
	Project Manager: Sheareen Jacobs
Contact: Michael O'Connor	Project Coordinator: Irene Rademacher
Standard: FCC, RSS-210, EN300 328, AS/NZS 4268:2008, EN 301 489-17 V2.1.1	Class: B

Conducted Emissions

(Elliott Laboratories Fremont Facility, Semi-Anechoic Chamber)

Test Specific Details

Objective: The objective of this test session is to perform final qualification testing of the EUT with respect to the specification listed above.

Date of Test: 7/12/2013	Config. Used: 1
Test Engineer: Joseph Cadigal	Config Change: none
Test Location: Fremont Chamber #5	EUT Voltage: 120V/60Hz

General Test Configuration

For tabletop equipment, the EUT was located on a wooden table inside the semi-anechoic chamber, 40 cm from a vertical coupling plane and 80cm from the LISN. A second LISN was used for all local support equipment. Remote support equipment was located outside of the semi-anechoic chamber. Any cables running to remote support equipment were routed through metal conduit and when possible passed through a ferrite clamp upon exiting the chamber.

Ambient Conditions:	Temperature:	25 °C
	Rel. Humidity:	30 %

Summary of Results

Run #	Test Performed	Limit	Result	Margin
1	CE, AC Power, 120V/60Hz	Class B	Pass	32.3 dBµV @ 7.229 MHz (-17.7 dB)

Modifications Made During Testing

No modifications were made to the EUT during testing

Deviations From The Standard

No deviations were made from the requirements of the standard.

Client: Griffin Technologies	Job Number: J92951
Model: MASM-02199 Bluetooth module (BC5)	T-Log Number: T92958
Contact: Michael O'Connor	Project Manager: Sheareen Jacobs
Standard: FCC, RSS-210, EN300 328, AS/NZS 4268:2008, EN 301 489-17 V2.1.1	Project Coordinator: Irene Rademacher
	Class: B

Run #1: AC Power Port Conducted Emissions, 0.15 - 30MHz, 120V/60Hz
 Center channel, EDR = 31, 1021, power setting 255, 50

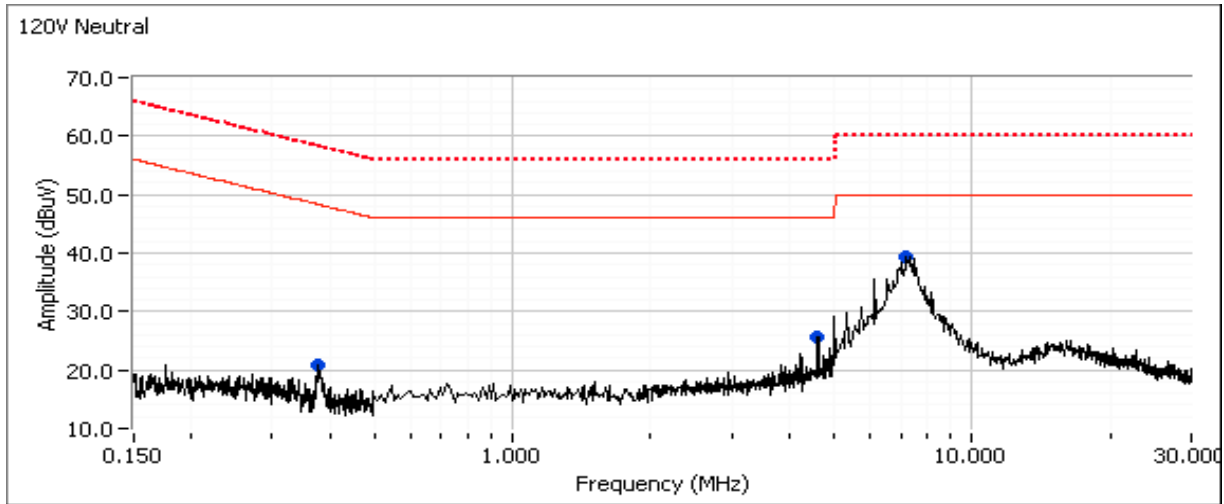
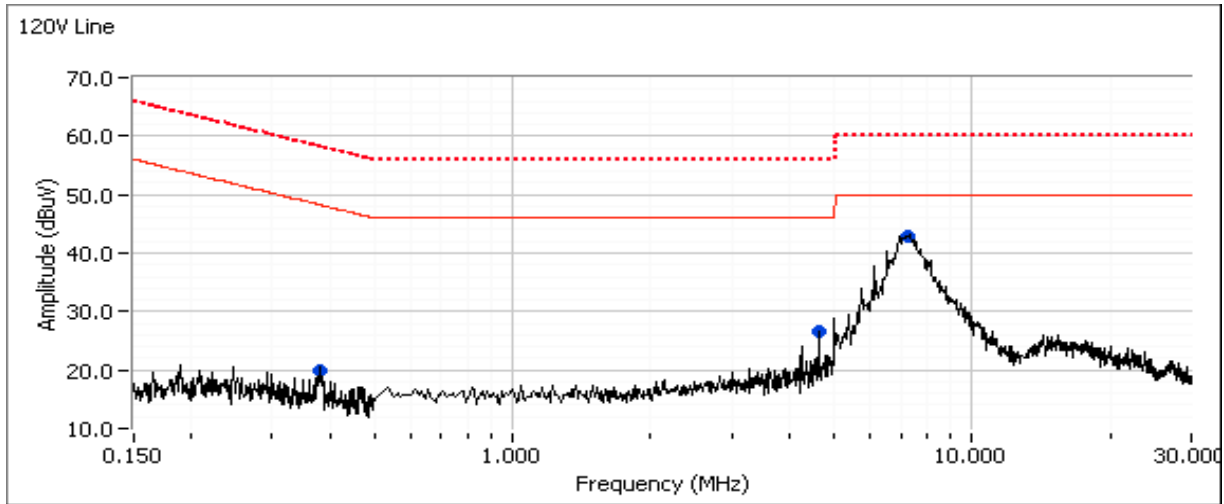



EMC Test Data

Client: Griffin Technologies	Job Number: J92951
Model: MASM-02199 Bluetooth module (BC5)	T-Log Number: T92958
	Project Manager: Sheareen Jacobs
Contact: Michael O'Connor	Project Coordinator: Irene Rademacher
Standard: FCC, RSS-210, EN300 328, AS/NZS 4268:2008, EN 301 489-17 V2.1.1	Class: B

Preliminary peak readings captured during pre-scan (peak readings vs. average limit)

Frequency MHz	Level dB μ V	AC Line	Class B		Detector QP/Ave	Comments
			Limit	Margin		
0.382	19.8	Line 1	48.2	-28.4	Peak	
4.634	26.5	Line 1	46.0	-19.5	Peak	
7.229	42.8	Line 1	50.0	-7.2	Peak	
0.378	20.7	Neutral	48.3	-27.6	Peak	
4.621	25.6	Neutral	46.0	-20.4	Peak	
7.203	39.4	Neutral	50.0	-10.6	Peak	

Final quasi-peak and average readings

Frequency MHz	Level dB μ V	AC Line	Class B		Detector QP/Ave	Comments
			Limit	Margin		
7.229	32.3	Line 1	50.0	-17.7	AVG	AVG (0.10s)
7.229	40.7	Line 1	60.0	-19.3	QP	QP (1.00s)
7.203	28.2	Neutral	50.0	-21.8	AVG	AVG (0.10s)
4.621	21.9	Neutral	46.0	-24.1	AVG	AVG (0.10s)
7.203	34.6	Neutral	60.0	-25.4	QP	QP (1.00s)
4.621	23.0	Neutral	56.0	-33.0	QP	QP (1.00s)
0.377	11.5	Neutral	48.3	-36.8	AVG	AVG (0.10s)
0.382	10.2	Line 1	48.2	-38.0	AVG	AVG (0.10s)
4.634	6.8	Line 1	46.0	-39.2	AVG	AVG (0.10s)
0.377	16.0	Neutral	58.3	-42.3	QP	QP (1.00s)
4.634	13.6	Line 1	56.0	-42.4	QP	QP (1.00s)
0.382	13.5	Line 1	58.2	-44.7	QP	QP (1.00s)

End of Report

This page is intentionally blank and marks the last page of this test report.