

Guangzhou ITS Communications Equipment Co., Ltd

DSRC Road-Side Units

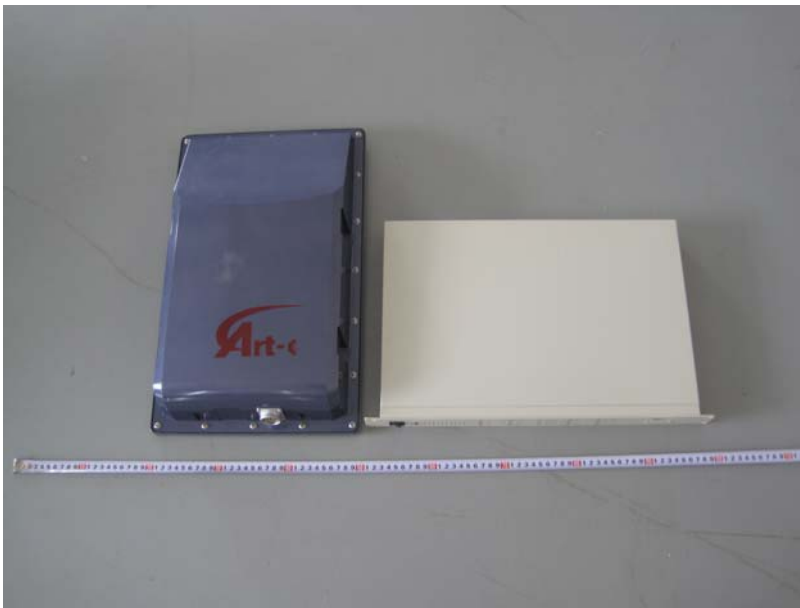

Model: DP268

Sep 17 2010
Report No.: 1002879
(This report supersedes NONE)

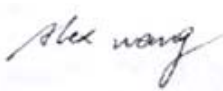

Modifications made to the product : None

This Test Report is Issued Under the Authority of:

	
Alex Wang Compliance Engineer	Will Yang Technical Manager

This test report may be reproduced in full only.
Test result presented in this test report is applicable to the representative sample only.

RF Test Report

TO: FCC 15.247

SIEMIC, INC.
Assessing global markets

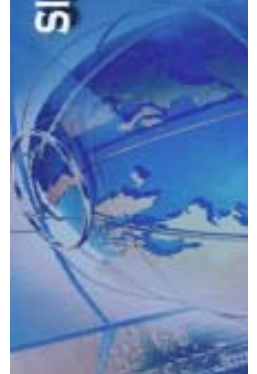

Laboratory Introduction

SIEMIC, headquartered in the heart of Silicon Valley, with superior facilities in US and Asia, is one of the leading independent testing and certification facilities providing customers with one-stop shop services for Compliance Testing and Global Certifications.



In addition to [testing](#) and [certification](#), SIEMIC provides initial design reviews and [compliance management](#) through out a project. Our extensive experience with [China](#), [Asia Pacific](#), [North America](#), [European](#), and [international](#) compliance requirements, assures the fastest, most cost effective way to attain regulatory compliance for the [global markets](#).

Accreditations for Conformity Assessment

Country/Region	Accreditation Body	Scope
USA	FCC, A2LA	EMC , RF/Wireless , Telecom
Canada	IC, A2LA, NIST	EMC, RF/Wireless , Telecom
Taiwan	BSMI , NCC , NIST	EMC, RF, Telecom , Safety
Hong Kong	OFTA , NIST	RF/Wireless ,Telecom
Australia	NATA, NIST	EMC, RF, Telecom , Safety
Korea	KCC/RRA, NIST	EMI, EMS, RF , Telecom, Safety
Japan	VCCI, JATE, TELEC, RFT	EMI, RF/Wireless, Telecom
Mexico	NOM, COFETEL, Caniety	Safety, EMC , RF/Wireless, Telecom
Europe	A2LA, NIST	EMC, RF, Telecom , Safety

Accreditations for Product Certifications

Country	Accreditation Body	Scope
USA	FCC TCB, NIST	EMC , RF , Telecom
Canada	IC FCB , NIST	EMC , RF , Telecom
Singapore	iDA, NIST	EMC , RF , Telecom



SIEMIC, INC.

Accessing global markets

Title: RF Test Report for DSRC Road-Side Units
Model: DP268
To: FCC 15.247.2009

Serial#: 1002879
Issue Date: Sep 17 2010
Page 3 of 73
www.siemac.com.cn

This page has been left blank intentionally.

CONTENTS

1 EXECUTIVE SUMMARY & EUT INFORMATION5

2 TECHNICAL DETAILS6

3 MODIFICATION7

4 TEST SUMMARY8

5 MEASUREMENTS, EXAMINATION AND DERIVED RESULTS9

ANNEX A. TEST INSTRUMENT & METHOD43

ANNEX B. EUT AND TEST SETUP PHOTOGRAPHS.....47

ANNEX C. TEST SETUP AND SUPPORTING EQUIPMENT.....57

ANNEX D. USER MANUAL / BLOCK DIAGRAM / SCHEMATICS / PART LIST61

ANNEX E. SIEMIC ACCREDITATION CERTIFICATES.....62

1 Executive Summary & EUT information

The purpose of this test programme was to demonstrate compliance of the Guangzhou ITS Communications Equipment Co., Ltd, DSRC Road-Side Units, and model: DP268 against the current Stipulated Standards. The DSRC Road-Side Unit has demonstrated compliance with the FCC 15.247:2009.

EUT Information

EUT	DSRC Road-Side Units
Description	
Model No	DP268
Input Power	24V DC
Classification Per Stipulated Test Standard	Class B Emission product per FCC 15.247:2009



SIEMIC, INC.

Accessing global markets

Title: RF Test Report for DSRC Road-Side Units
Model: DP268
To: FCC 15.247:2009

Serial#: 1002879
Issue Date: Sep 17 2010
Page 6 of 73
www.siemec.com.cn

2 TECHNICAL DETAILS

Purpose	Compliance testing of DSRC Road-Side Units with stipulated standard
Applicant / Client	Guangzhou ITS Communications Equipment Co., Ltd No. 1 gaojiayuan Chaoyang District Beijing P.R.China
Manufacturer	Guangzhou ITS Communications Equipment Co., Ltd 5th, Hua Feng Road, Yonghe Economic Development Zone, Luogang, Guang Zhou, Guang Dong Province
Laboratory performing the tests	SIEMIC Nanjing (China) Laboratories NO.2-1,Longcang Dadao, Yuhua Economic Development Zone, Nanjing, China Tel:+86(25)86730128/86730129 Fax:+86(25)86730127 Email:info@siemic.com
Test report reference number	1002493
Date EUT received	Sep 11 2010
Standard applied	FCC 15.247:2009
Dates of test (from – to)	Sep 11~17 2010
No of Units:	#2
Equipment Category:	DTS
Trade Name:	ARTC
Model :	DP268
RF Operating Frequency (ies)	TX:5750.10-5845.10MHz
Modulation :	ASK
FCC ID:	YH7ARTCRSUDP268-2

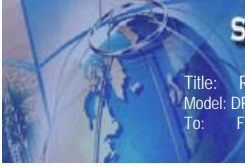

SIEMIC, Inc.

Accessing global markets

Title: RF Test Report for DSRC Road-Side Units
Model: DP268
To: FCC 15.247:2009

Serial#: 1002879
Issue Date: Sep 17 2010
Page 7 of 73
www.siemac.com.cn

3 MODIFICATION

NONE

4 TEST SUMMARY

The product was tested in accordance with the following specifications. All Testing has been performed according to below product classification:

DTS

Test Results Summary

Test Standard	Description	Pass / Fail
CFR 47 Part 15.247: 2008		
15.203	Antenna Requirement	Pass
15.205	Restricted Band of Operation	Pass
15.207(a)	Conducted Emissions Voltage	Pass
15.247(a)(1)	Channel Separation	N/A
15.247(a)(1)	Occupied Bandwidth	Pass
15.247(a)(2)	6dB Bandwidth	Pass
15.247(a)(1)	Number of Hopping Channels	N/A
15.247(a)(1)	Time of Occupancy	N/A
15.247(b)	Output Power	Pass
15.247(c)	Antenna Gain > 6 dBi	Pass
15.247(d)	Conducted Spurious Emissions	Pass
15.209; 15.247(d)	Radiated Spurious Emissions	Pass
15.247(e)	Power Spectral Density	Pass
15.247(f)	Hybrid System Requirement	N/A
15.247(g)	Hopping Capability	N/A
15.247(h)	Hopping Coordination Requirement	N/A
15.247(i)	RF Exposure requirement	Pass

ANSI C63.4: 2003

PS: Preliminary AC line and radiated emissions testing has been performed on all models, only worst case test result is presented in this test report.

5 MEASUREMENTS, EXAMINATION AND DERIVED RESULTS

5.1 Antenna Requirement

Requirement(s): 47 CFR §15.203

An intentional radiator shall be designed to ensure that no antenna other than that furnished by the responsible party shall be used with the device.

Antenna requirement must meet at least one of the following:

- a) Antenna must be permanently attached to the device.
- b) Antenna must use a unique type of connector to attach to the device.
- c) Device must be professionally installed. Installer shall be responsible for ensuring that the correct antenna is employed with the device.

The antenna is integral antenna. Antenna maximum gain is 13 dBi.

5.2 Conducted Emissions Voltage

Requirement:

Frequency of emission (MHz)	Conducted limit (dB μ V)	
	Quasi-peak	Average
0.15–0.5	66 to 56*	56 to 46*
0.5–5	56	46
5–30	60	50

*Decreases with the logarithm of the frequency.

Procedures:

- All possible modes of operation were investigated. Only the 6 worst case emissions measured, using the correct CISPR and Average detectors, are reported. All other emissions were relatively insignificant.
- A "-ve" margin indicates a PASS as it refers to the margin present below the limit line at the particular frequency.
- Conducted Emissions Measurement Uncertainty
All test measurements carried out are traceable to national standards. The uncertainty of the measurement at a confidence level of approximately 95% (in the case where distributions are normal), with a coverage factor of 2, in the range 9kHz – 30MHz (Average & Quasi-peak) is ± 3.5 dB.
- Environmental Conditions

Temperature	23°C
Relative Humidity	50%
Atmospheric Pressure	1019mbar
- Test date : Sep 11~17 2010
Tested By : Alex Wang

Neutral --Operating mode: transmitting

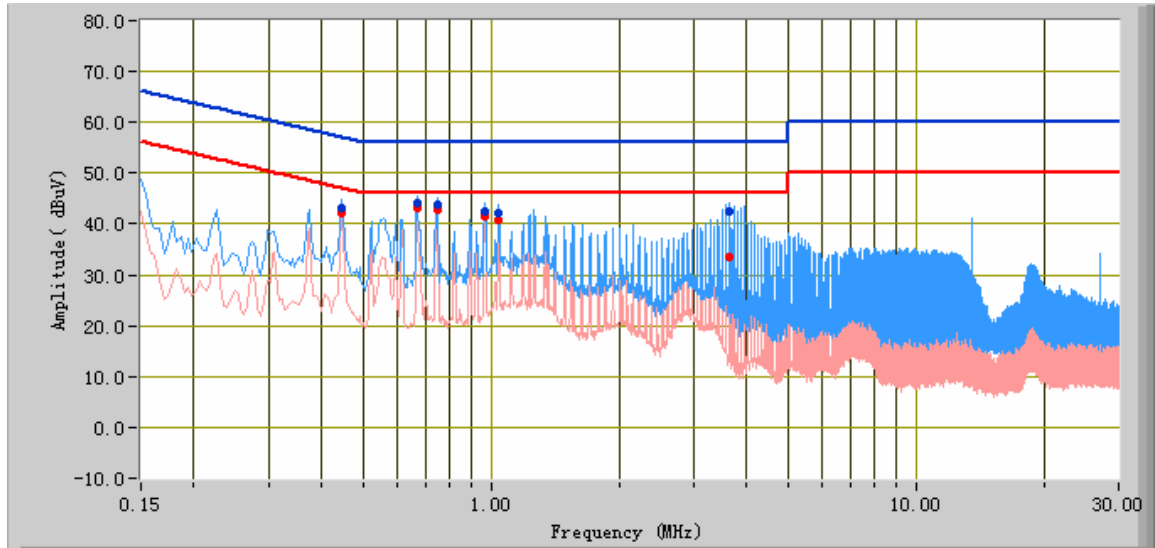

Frequency (MHz)	Quasi Peak (dBuV)	Limit (dBuV)	Margin (dB)	Average (dBuV)	Limit (dBuV)	Margin (dB)	Factors (dB)
0.67	44.06	56.00	-11.94	43.28	46.00	-2.72	10.13
0.75	43.75	56.00	-12.25	42.93	46.00	-3.07	10.14
3.65	42.47	56.00	-13.53	33.58	46.00	-12.42	10.40
0.97	42.56	56.00	-13.44	41.49	46.00	-4.51	10.16
0.45	43.24	56.96	-13.73	42.29	46.96	-4.68	10.17
1.04	42.01	56.00	-13.99	40.79	46.00	-5.21	10.16

Line --Operating mode: transmitting

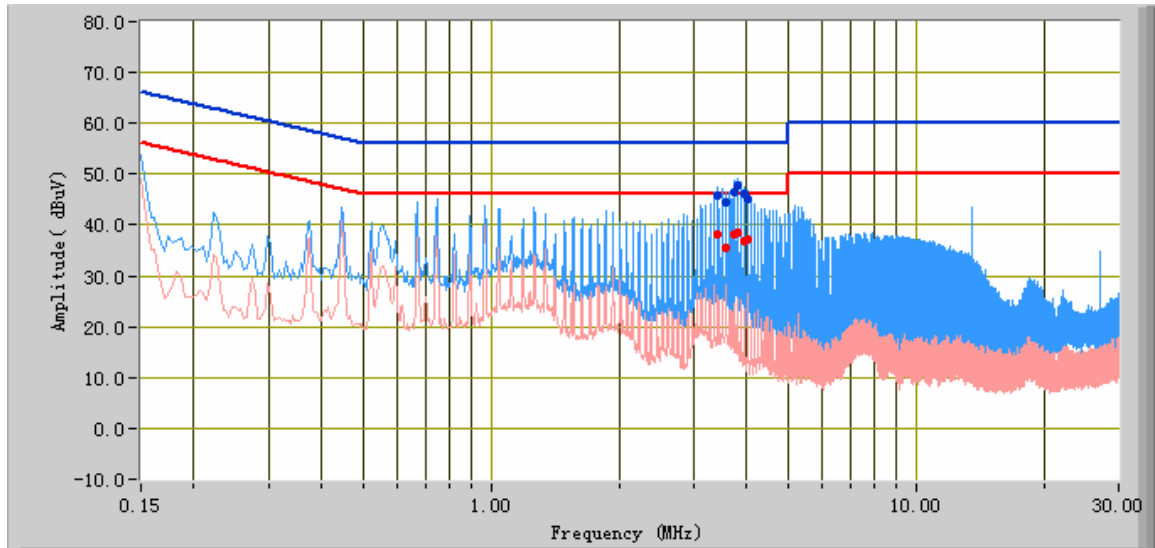

Frequency (MHz)	Quasi Peak (dBuV)	Limit (dBuV)	Margin (dB)	Average (dBuV)	Limit (dBuV)	Margin (dB)	Factors (dB)
3.80	47.90	56.00	-8.10	38.47	46.00	-7.53	10.47
3.72	46.37	56.00	-9.63	38.02	46.00	-7.98	10.44
3.95	46.11	56.00	-9.89	36.81	46.00	-9.19	10.51
3.43	45.69	56.00	-10.31	38.02	46.00	-7.98	10.35
4.02	45.20	56.00	-10.80	37.03	46.00	-8.97	10.53
3.58	44.56	56.00	-11.44	35.53	46.00	-10.47	10.40

5.3 6dB Occupied Bandwidth

1. Conducted Measurement
EUT was set for low, mid, high channel with modulated mode and highest RF output power.
The spectrum analyzer was connected to the antenna terminal.
2. Environmental Conditions

Temperature	23°C
Relative Humidity	50%
Atmospheric Pressure	1019mbar
3. Conducted Emissions Measurement Uncertainty
All test measurements carried out are traceable to national standards. The uncertainty of the measurement at a confidence level of approximately 95% (in the case where distributions are normal), with a coverage factor of 2, in the range 30MHz – 40GHz is ±1.5dB.
4. Test date : Sep 11~17 2010
Tested By : Alex Wang

Requirement(s): 47 CFR § 15.247(a)(1)

Procedures: The 6dB Bandwidths were measured conducted using a spectrum analyzer at low, mid, and hi channels. 6dB Bandwidth Limit: >500kHz.

Channel Frequency (MHz)	6dB Occupied Bandwidth Limit (MHz)	6dB Channel Bandwidth (MHz)
5750.10	0.5	1.20
5800.10	0.5	1.20
5845.10	0.5	1.10



SIEMIC, INC.

Accessing global markets

Title: RF Test Report for DSRC Road-Side Units
Model: DP268
To: FCC 15.247.2009

Serial#: 1002879
Issue Date: Sep 17 2010
Page: 14 of 73
www.siemic.com.cn

Refer to the attached plots.

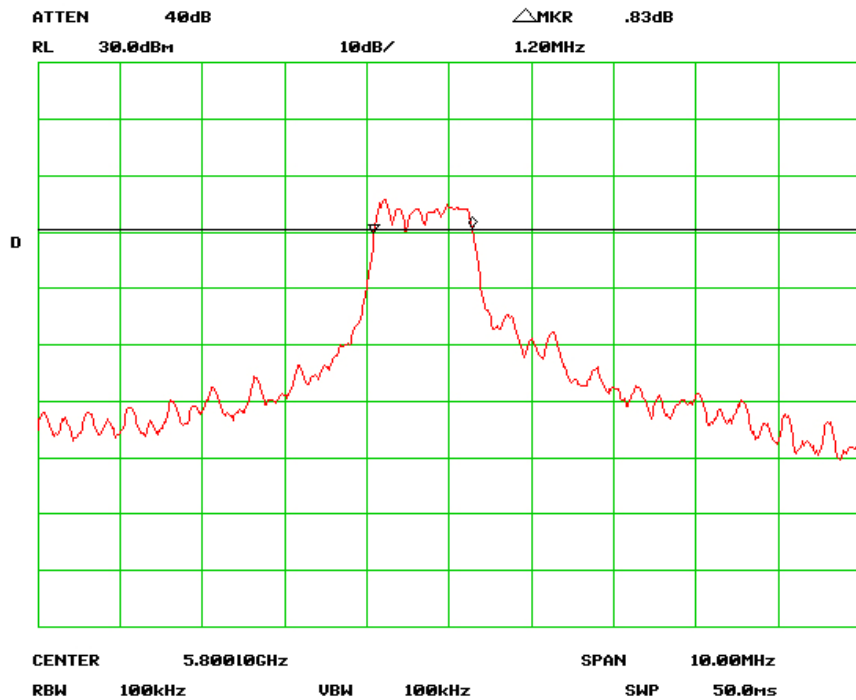
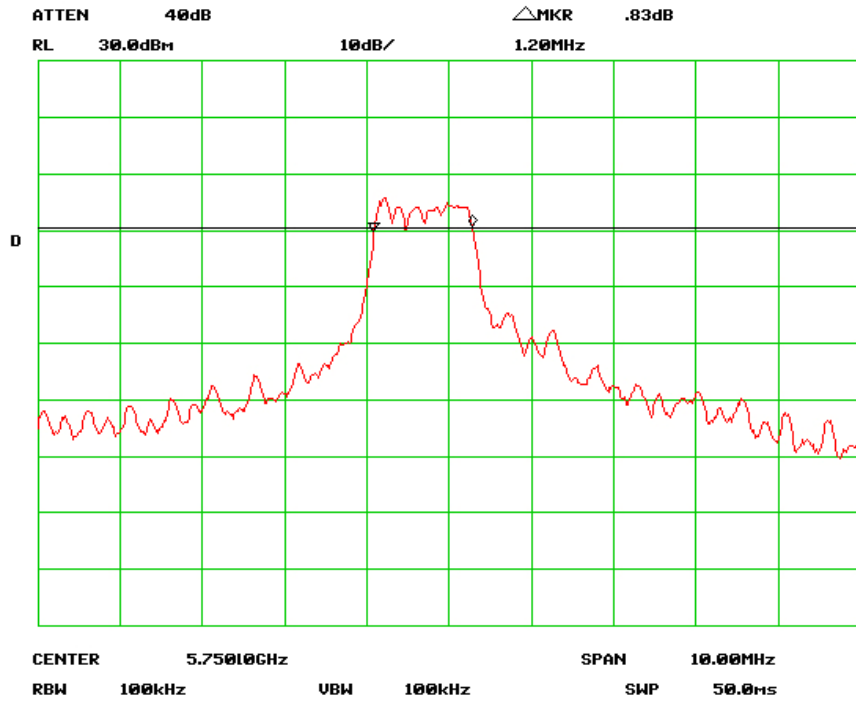



SIEMIC, INC.

Accessing global markets

Title: RF Test Report for DSRC Road-Side Units
Model: DP268
To: FCC 15.247.2009

Serial#: 1002879
Issue Date: Sep 17 2010
Page: 15 of 73
www.siemec.com.cn

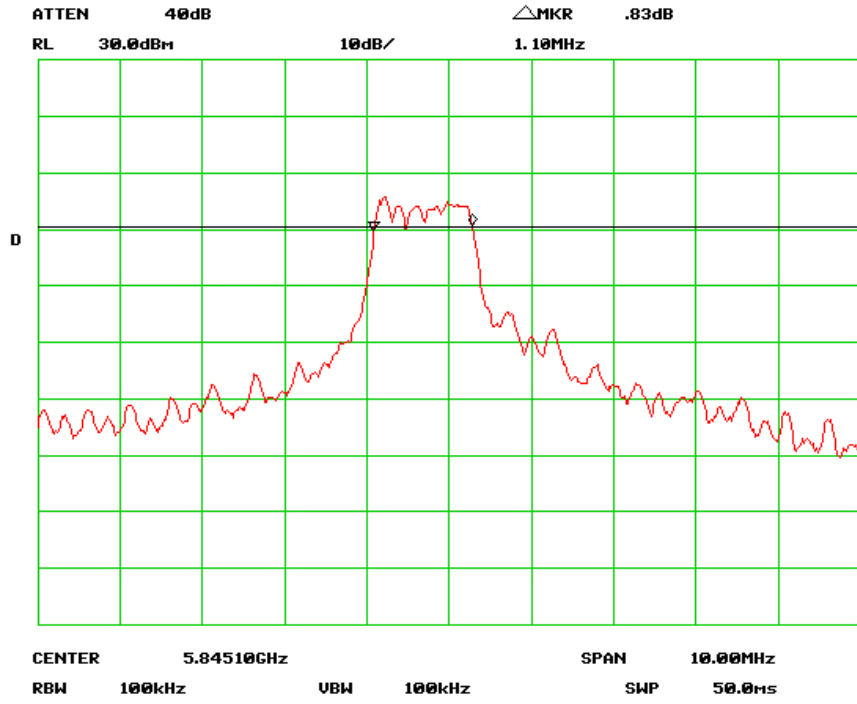

5.4 Power Spectral Density

1. Conducted Measurement
EUT was set for low, mid, high channel with modulated mode and highest RF output power. The spectrum analyzer was connected to the antenna terminal.
2. Environmental Conditions

Temperature	23°C
Relative Humidity	50%
Atmospheric Pressure	1019mbar
3. Conducted Emissions Measurement Uncertainty
All test measurements carried out are traceable to national standards. The uncertainty of the measurement at a confidence level of approximately 95% (in the case where distributions are normal), with a coverage factor of 2, in the range 30MHz – 40GHz is ±1.5dB.
4. Test date : Sep 11~17 2010
Tested By : Alex Wang

Requirement(s): 47 CFR § 15.247(e)

For digitally modulated systems, the power spectral density conducted from the intentional radiator to the antenna shall not be greater than 8dBm in any 3KHz band during any time interval of continuous transmission.

Procedures: The power spectral density measurement was taken conducted using a spectrum analyzer.

RBW=3KHz, VBW>RBW, Sweep time to SPAN/RBW(s).

The result:

Channel Frequency (MHz)	Peak Spectral Density Limit (dBm/3KHz)	Peak Spectral Density (dBm/3KHz)
5750.10	8	-6.50
5800.10	8	-6.30
5845.10	8	-6.10



SIEMIC, INC.

Accessing global markets

Title: RF Test Report for DSRC Road-Side Units
Model: DP268
To: FCC 15.247.2009

Serial#: 1002879
Issue Date: Sep 17 2010
Page: 17 of 73
www.siemac.com.cn

Refer to the attached plots.

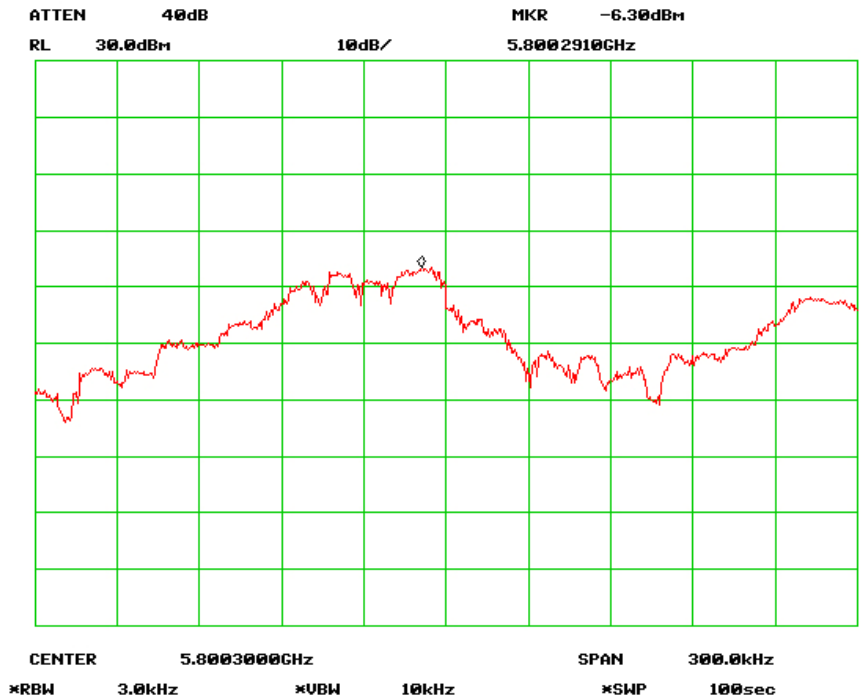
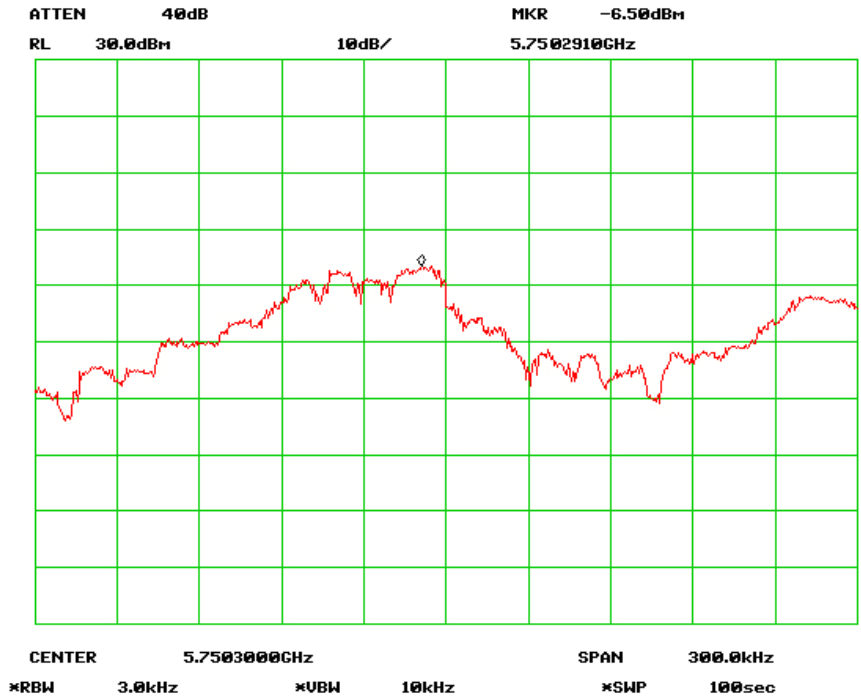



SIEMIC, Inc.

Accessing global markets

Title: RF Test Report for DSRC Road-Side Units
Model: DP268
To: FCC 15.247.2009

Serial#: 1002879
Issue Date: Sep 17 2010
Page: 18 of 73
www.siemec.com.cn

ATTEN 40dB MKR -6.10dBm
RL 30.0dBm 10dB/ 5.8452930CHz



CENTER 5.8453000CHz SPAN 300.0kHz
*RBW 3.0kHz *UBW 10kHz *SWP 100sec

5.5 Peak Output Power

1. **Conducted Measurement**
EUT was set for low, mid, high channel with modulated mode and highest RF output power. The spectrum analyzer was connected to the antenna terminal.
2. **Conducted Emissions Measurement Uncertainty**
All test measurements carried out are traceable to national standards. The uncertainty of the measurement at a confidence level of approximately 95% (in the case where distributions are normal), with a coverage factor of 2, in the range 30MHz – 40GHz is ± 1.5 dB.
3. **Environmental Conditions**

Temperature	23°C
Relative Humidity	50%
Atmospheric Pressure	1019mbar
4. Test date : Sep 11~17 2010
Tested By : Alex Wang

Standard Requirement: 47 CFR § 15.247(b)

Procedures: The peak output power was measured conducted using a spectrum analyzer at low, mid, and hi channels. Peak detector was set to measure the power output. The power is converted from watt to dBm, therefore, 1 watt = 30 dBm.

Test Result:

Channel Frequency (MHz)	Peak Output Power Limit (dBm)	Measured Output Power (dBm)
5750.10	30	13.30
5800.10	30	13.40
5845.10	30	13.30



SIEMIC, INC.

Accessing global markets

Title: RF Test Report for DSRC Road-Side Units
Model: DP268
To: FCC 15.247:2009

Serial#: 1002879
Issue Date: Sep 17 2010
Page: 20 of 73
www.siemec.com.cn

Refer to the attached plots.

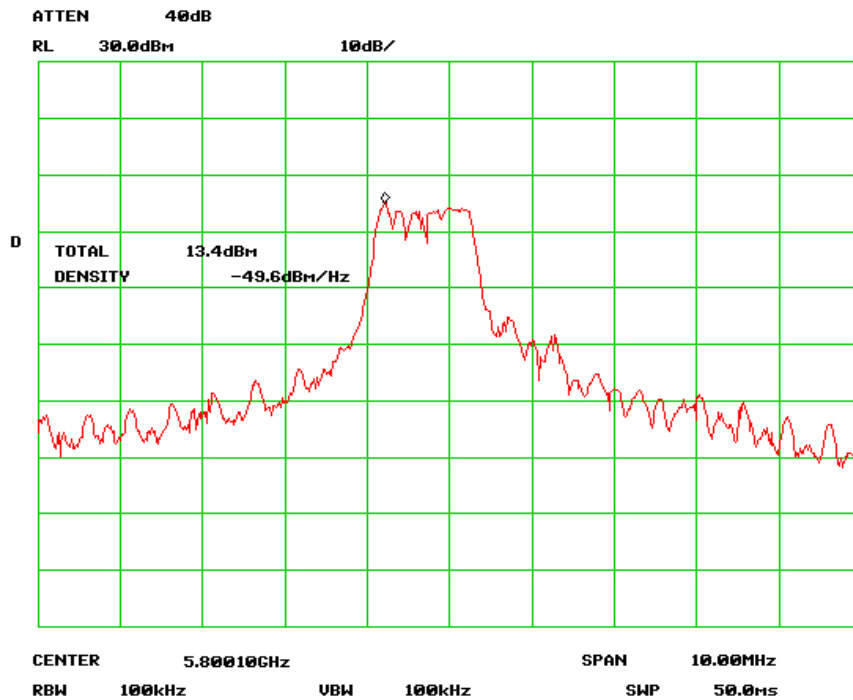
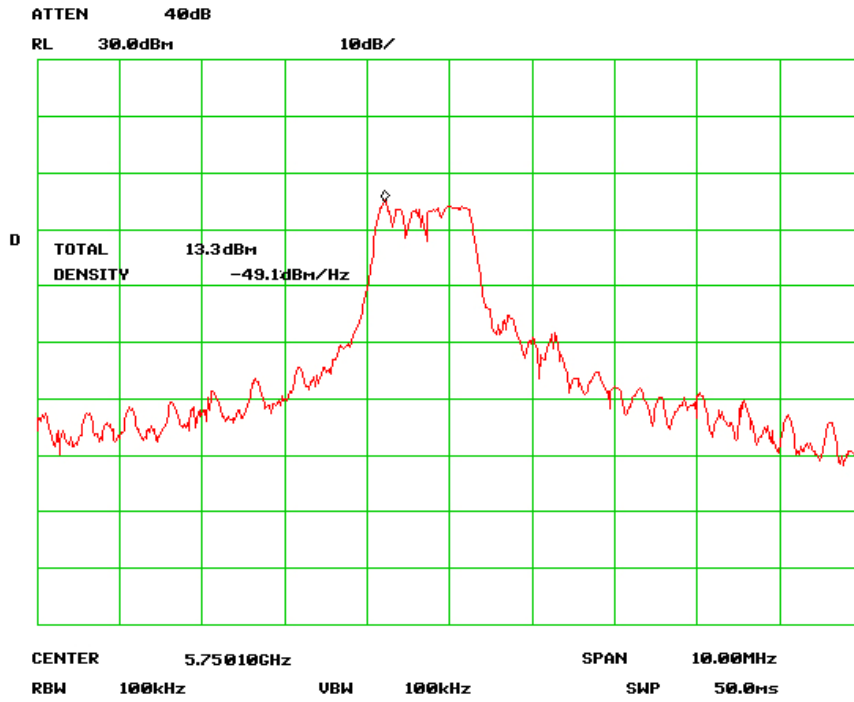



SIEMIC, INC.

Accessing global markets

Title: RF Test Report for DSRC Road-Side Units
Model: DP268
To: FCC 15.247.2009

Serial#: 1002879
Issue Date: Sep 17 2010
Page 21 of 73
www.siemic.com.cn

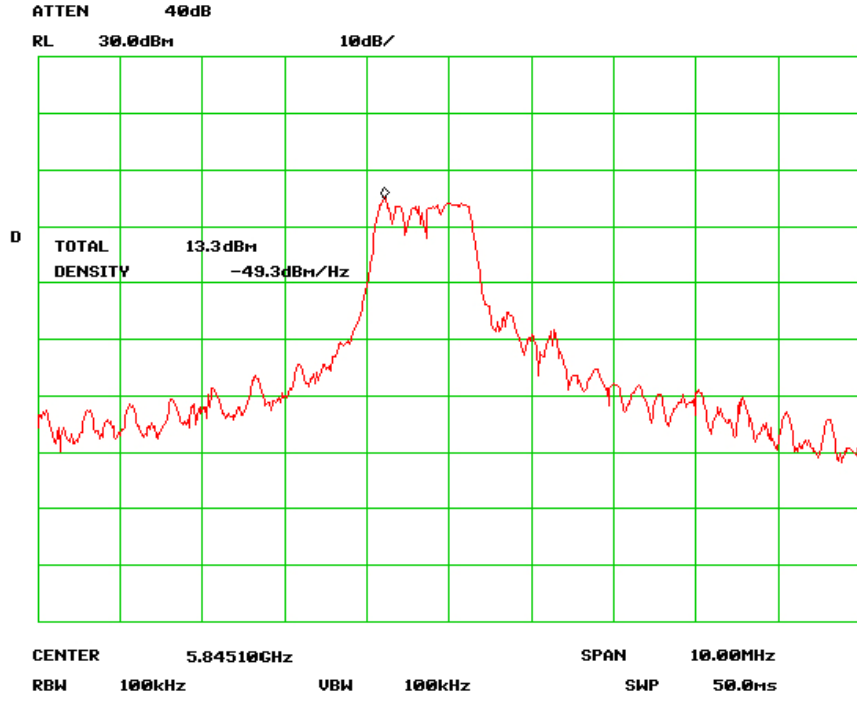

5.6 Antenna Port Emission

1. Conducted Measurement
EUT was set for low, mid, high channel with modulated mode and highest RF output power.
The spectrum analyzer was connected to the antenna terminal.
2. Conducted Emissions Measurement Uncertainty
All test measurements carried out are traceable to national standards. The uncertainty of the measurement at a confidence level of approximately 95% (in the case where distributions are normal), with a coverage factor of 2, in the range 30MHz – 40GHz is ±1.5dB.
3. Environmental Conditions
Temperature 23°C
Relative Humidity 50%
Atmospheric Pressure 1019mbar
4. Test date : Sep 11~17 2010
Tested By : Alex Wang

Standard Requirement: Radiated emission limits: In any 100 kHz bandwidth outside the frequency band in which the spread spectrum intentional radiator is operating, the radio frequency power that is produced by the modulation products of the spreading sequence, the information sequence and the carrier frequency shall be at least 20 dB below that in the 100 kHz bandwidth within the band that contains the highest level of the desired power

Procedures: The conducted spurious emissions were measured conducted using a spectrum analyzer at low, mid, and hi channels. The limit was determined by attenuating 20 dB of the RF peak power output.

Test Result: Pass

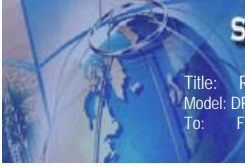

SIEMIC, INC.

Accessing global markets

Title: RF Test Report for DSRC Road-Side Units
Model: DP268
To: FCC 15.247:2009

Serial#: 1002879
Issue Date: Sep 17 2010
Page 23 of 73
www.siemec.com.cn

Channel 5750.10MHz

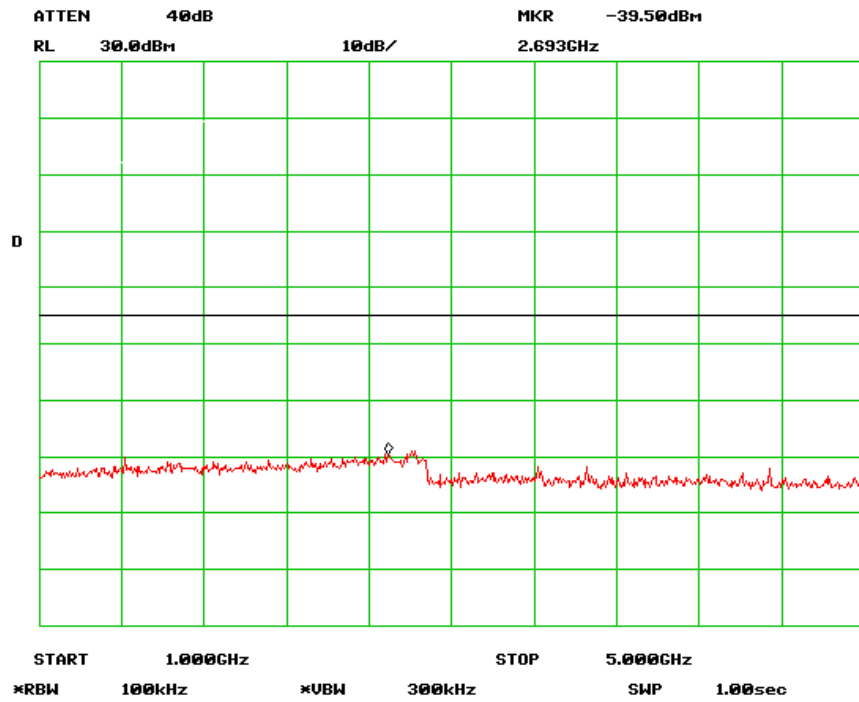
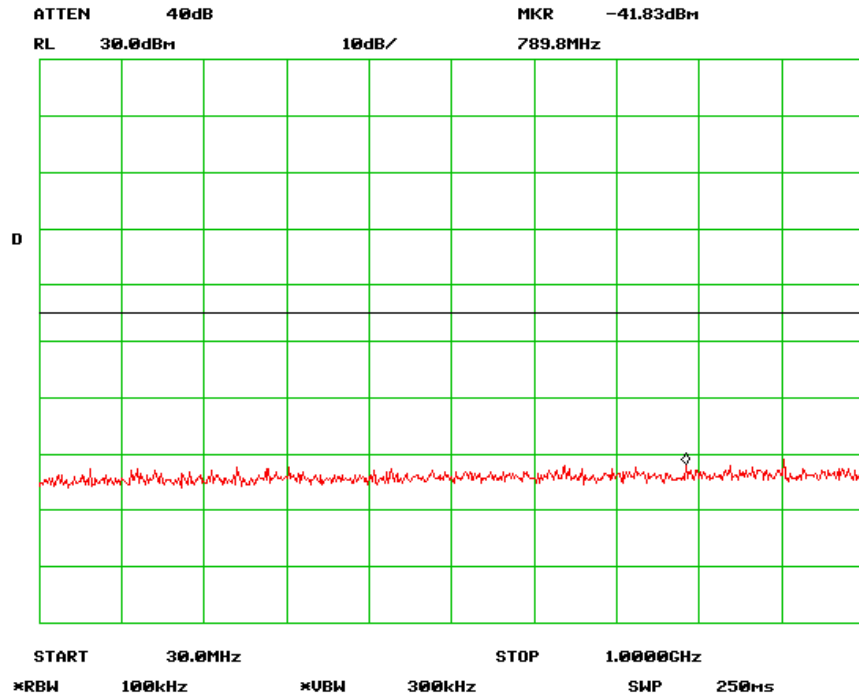



SIEMIC, INC.

Accessing global markets

Title: RF Test Report for DSRC Road-Side Units
Model: DP268
To: FCC 15.247.2009

Serial#: 1002879
Issue Date: Sep 17 2010
Page: 24 of 73
www.siemec.com.cn

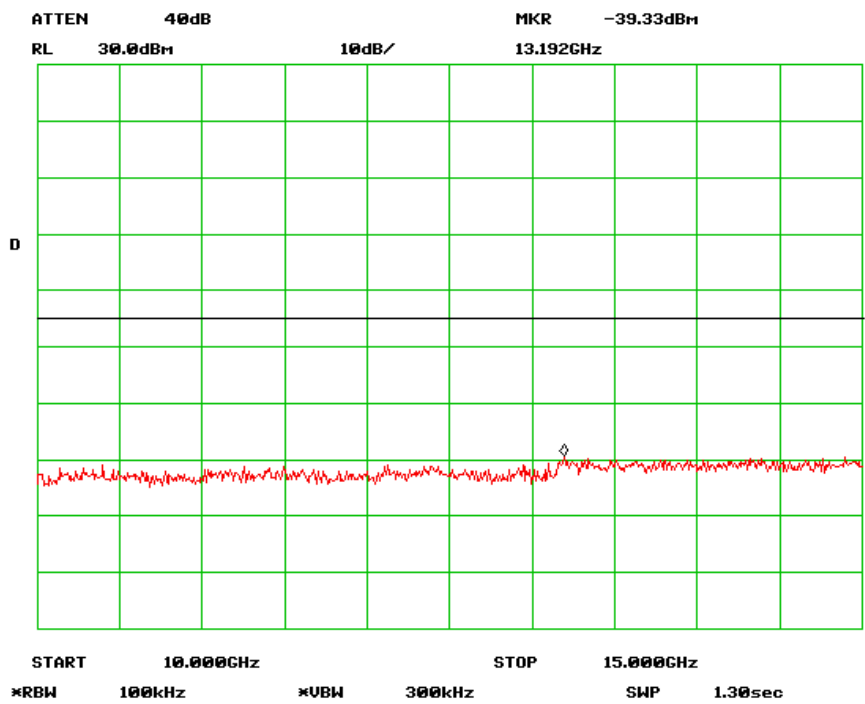
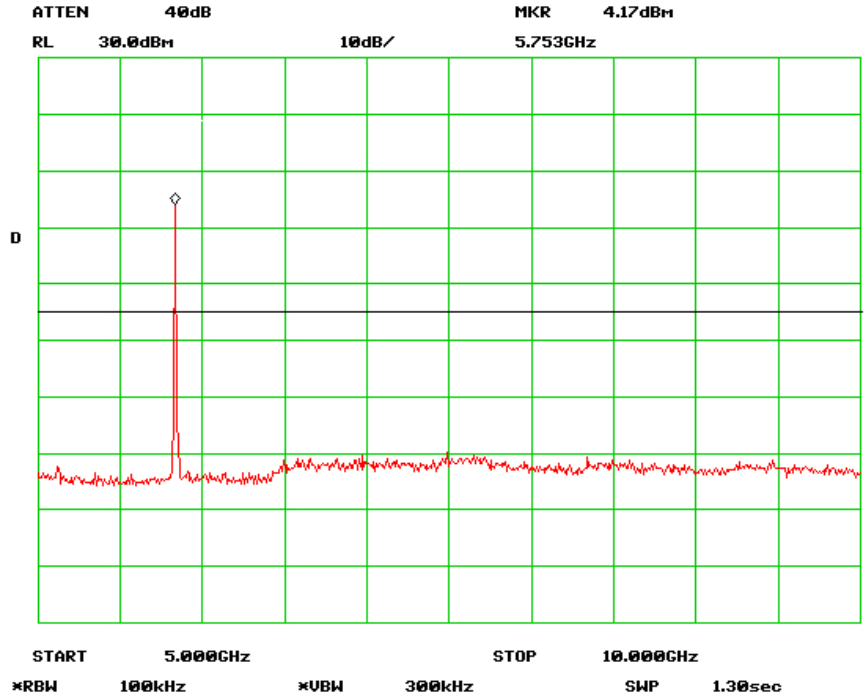



SIEMIC, Inc.

Accessing global markets

Title: RF Test Report for DSRC Road-Side Units
Model: DP268
To: FCC 15.247.2009

Serial#: 1002879
Issue Date: Sep 17 2010
Page: 25 of 73
www.siemec.com.cn

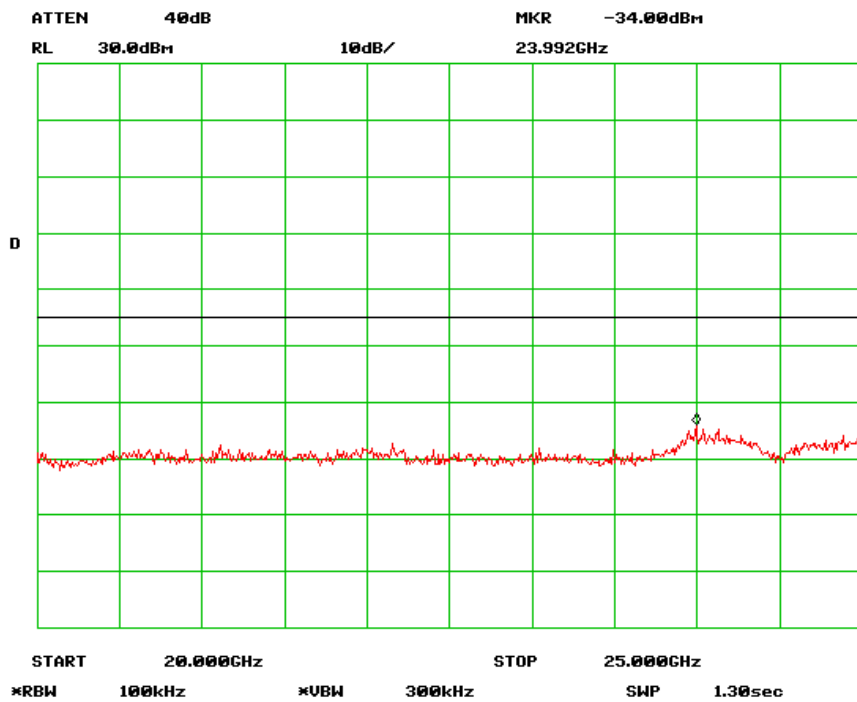
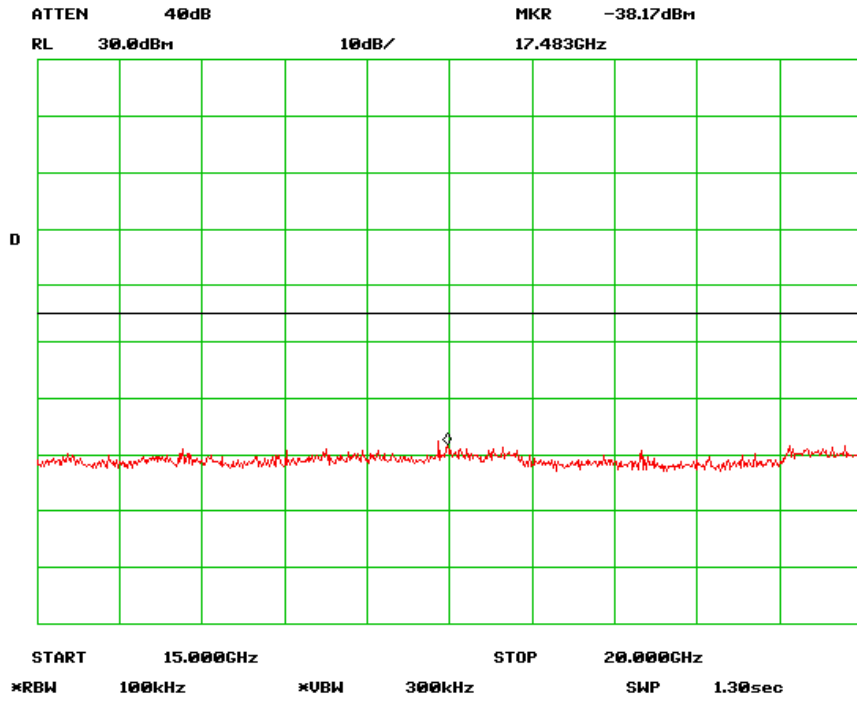



SIEMIC, Inc.

Accessing global markets

Title: RF Test Report for DSRC Road-Side Units
Model: DP268
To: FCC 15.247.2009

Serial#: 1002879
Issue Date: Sep 17 2010
Page: 26 of 73
www.siemec.com.cn

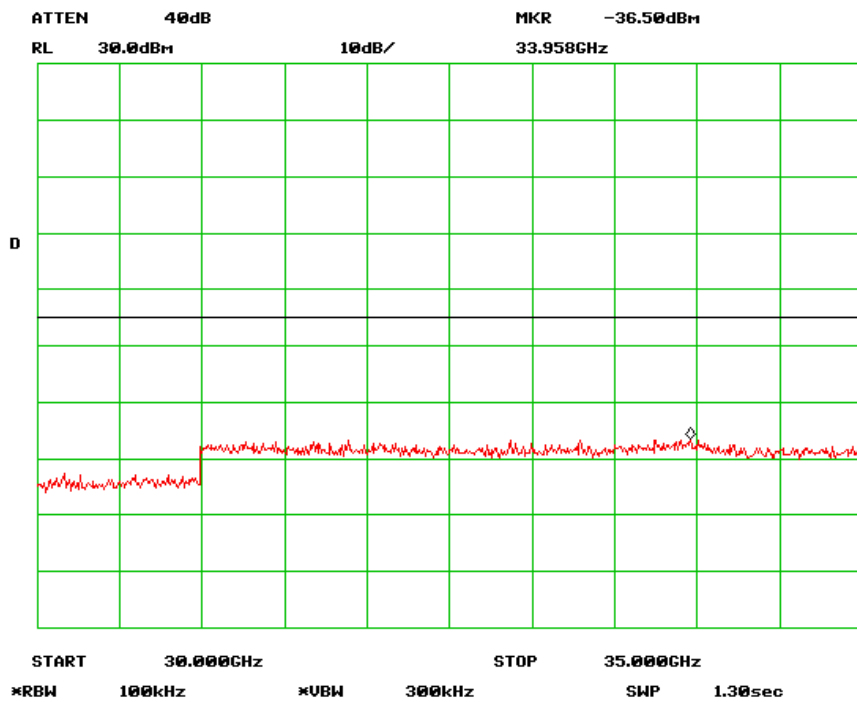
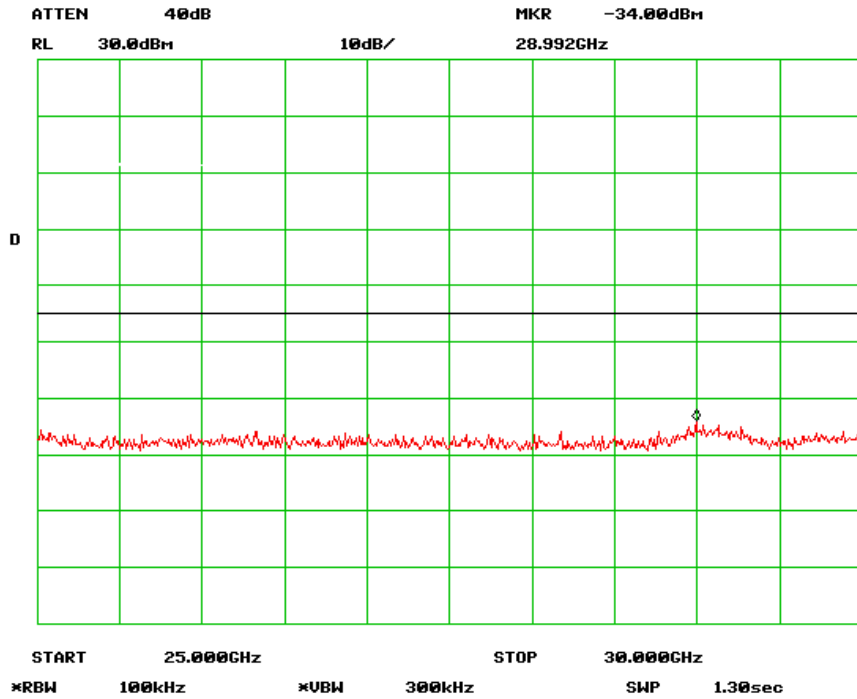



SIEMIC, Inc.

Accessing global markets

Title: RF Test Report for DSRC Road-Side Units
Model: DP268
To: FCC 15.247.2009

Serial#: 1002879
Issue Date: Sep 17 2010
Page 27 of 73
www.siemec.com.cn

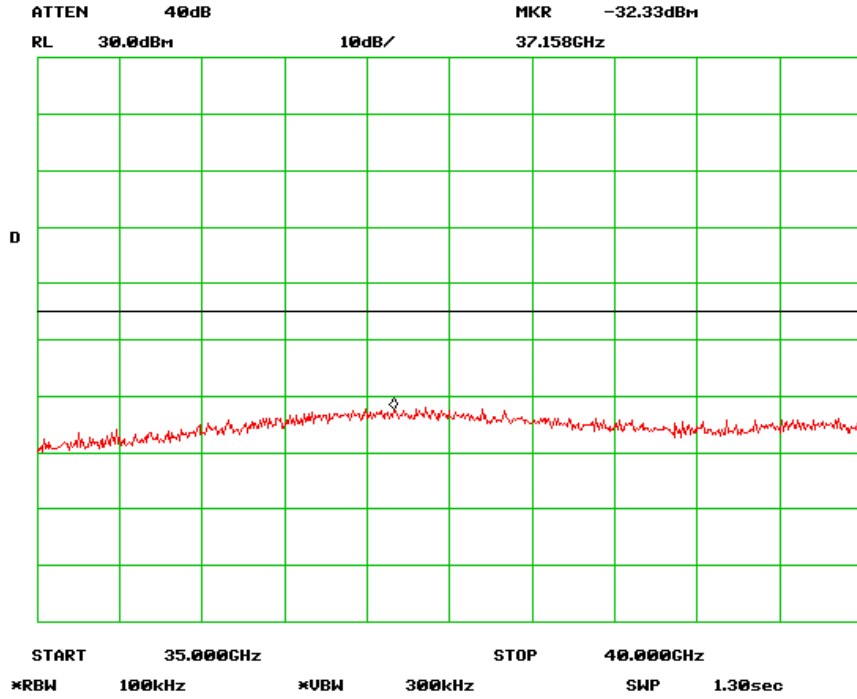



SIEMIC, INC.

Accessing global markets

Title: RF Test Report for DSRC Road-Side Units
Model: DP268
To: FCC 15.247:2009

Serial#: 1002879
Issue Date: Sep 17 2010
Page 28 of 73
www.siemc.com.cn

Channel 5800.10MHz

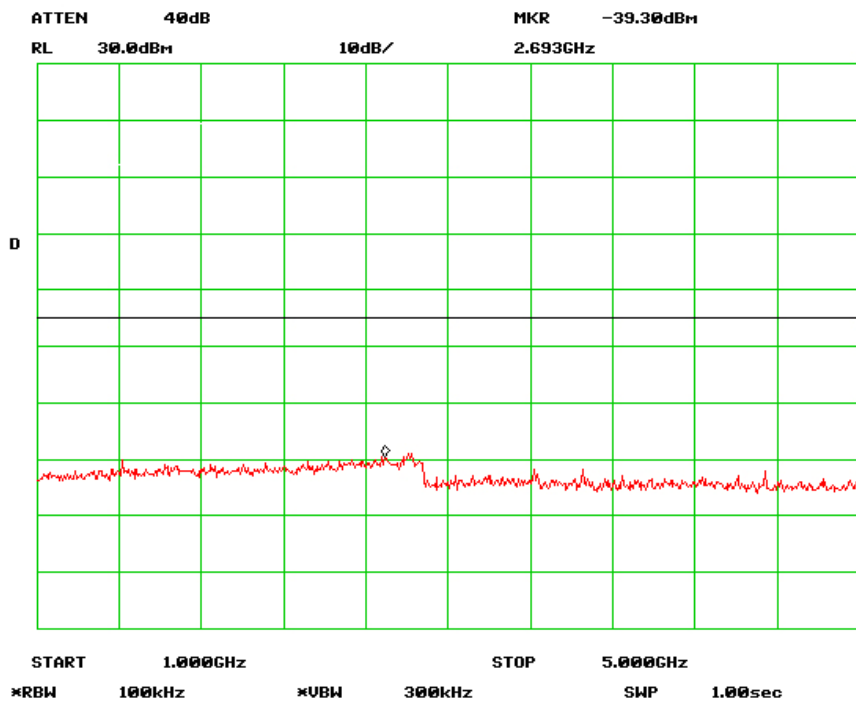
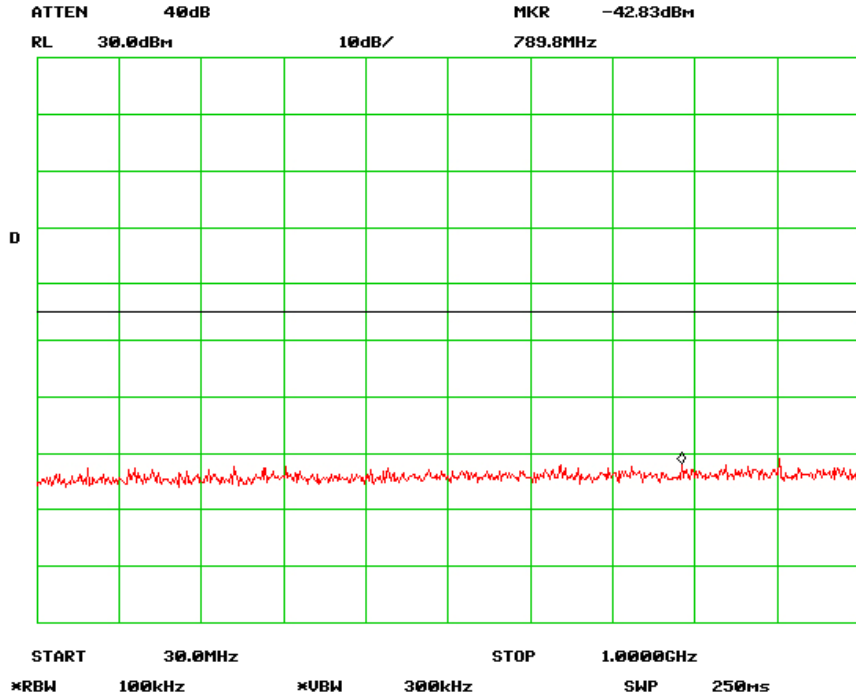



SIEMIC, INC.

Accessing global markets

Title: RF Test Report for DSRC Road-Side Units
Model: DP268
To: FCC 15.247.2009

Serial#: 1002879
Issue Date: Sep 17 2010
Page: 29 of 73
www.siemec.com.cn

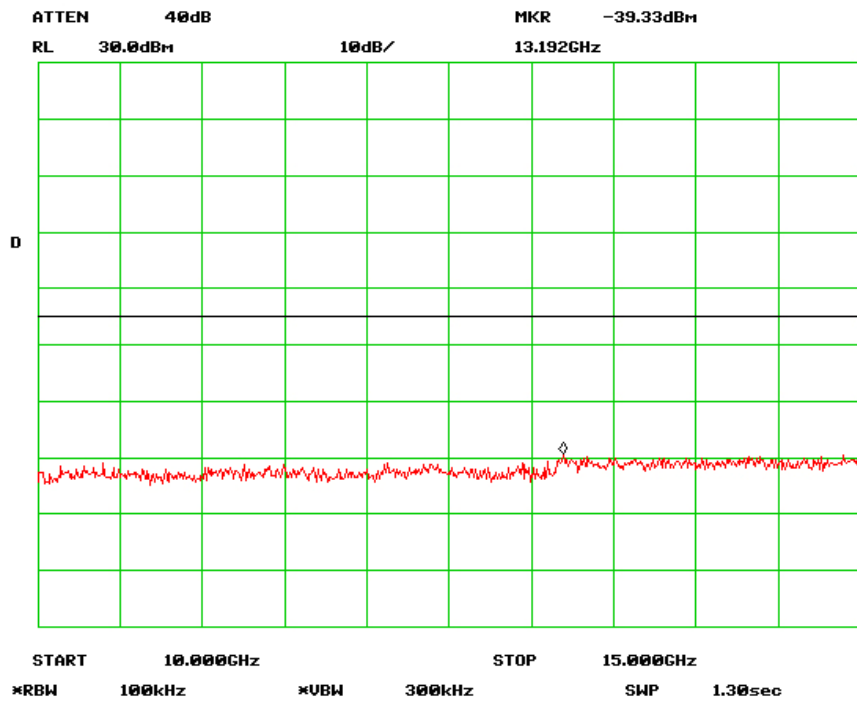
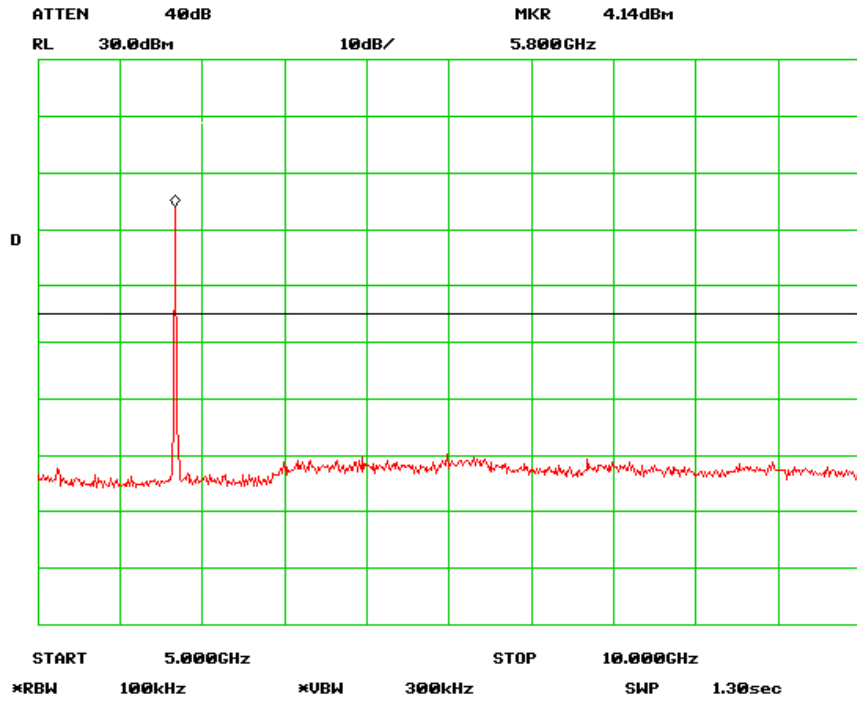



SIEMIC, INC.

Accessing global markets

Title: RF Test Report for DSRC Road-Side Units
Model: DP268
To: FCC 15.247.2009

Serial#: 1002879
Issue Date: Sep 17 2010
Page 30 of 73
www.siemac.com.cn

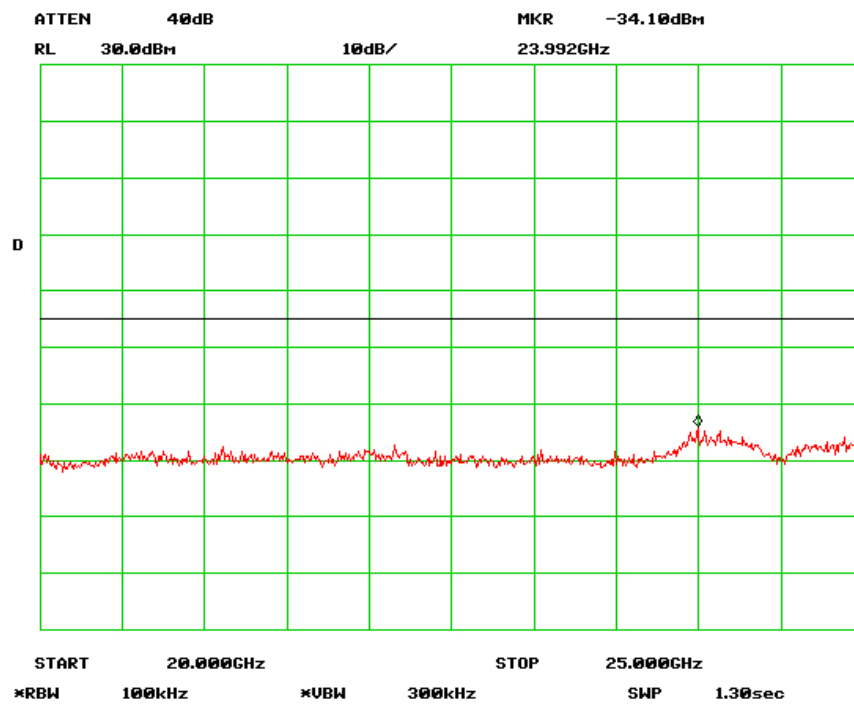
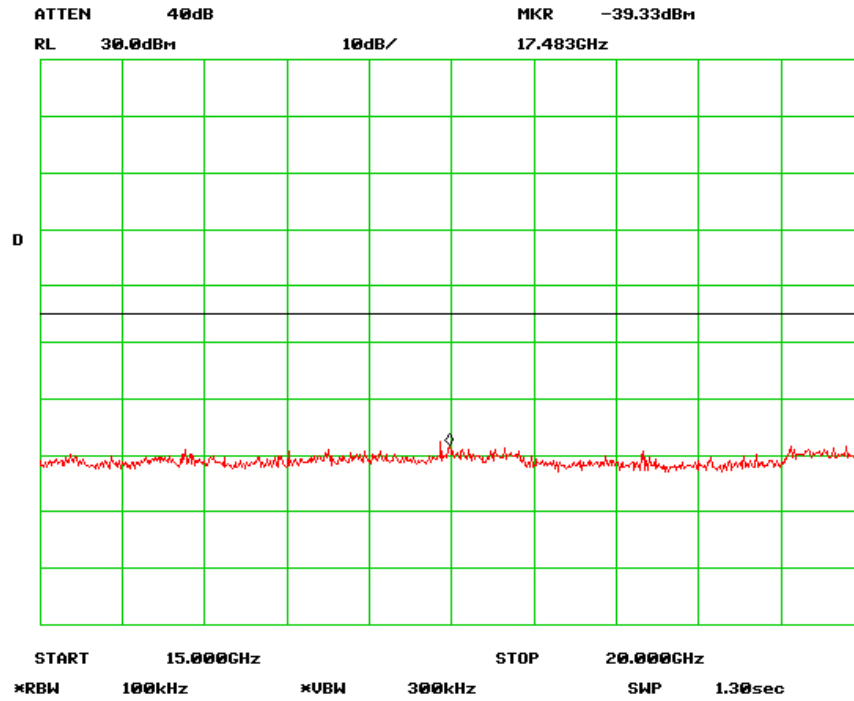



SIEMIC, Inc.

Accessing global markets

Title: RF Test Report for DSRC Road-Side Units
Model: DP268
To: FCC 15.247.2009

Serial#: 1002879
Issue Date: Sep 17 2010
Page 31 of 73
www.siemac.com.cn

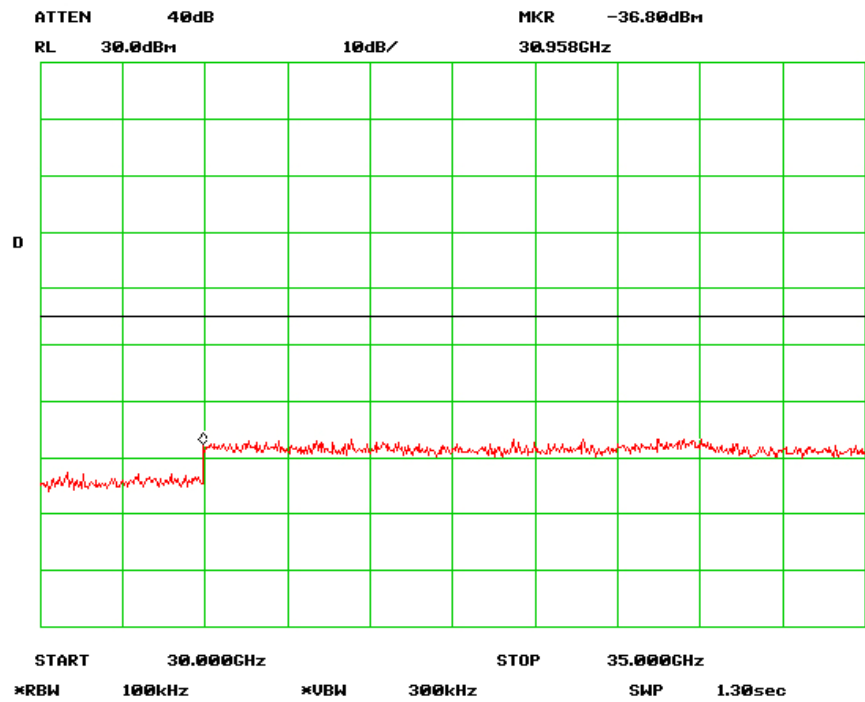
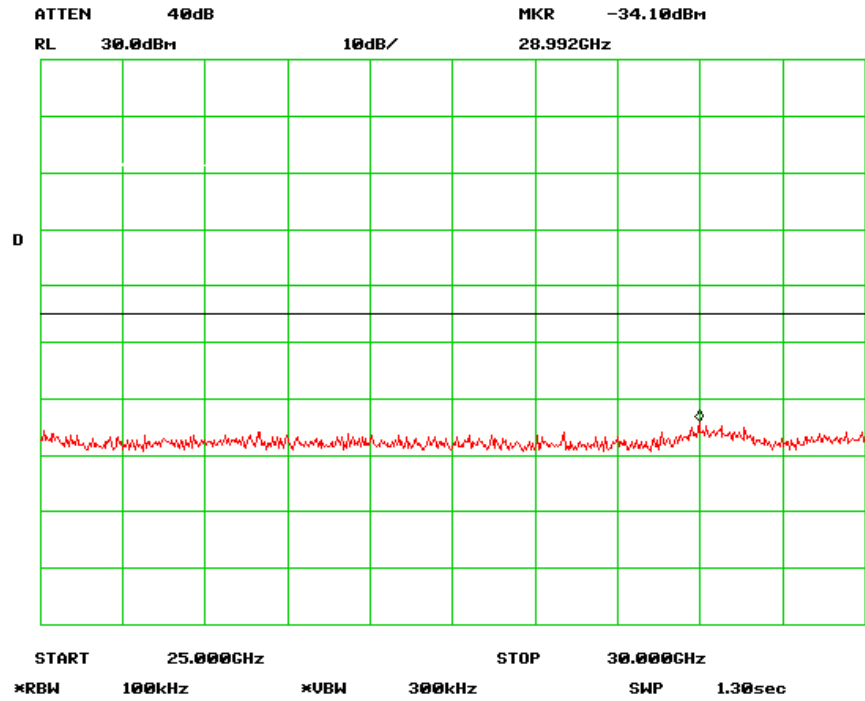



SIEMIC, INC.

Accessing global markets

Title: RF Test Report for DSRC Road-Side Units
Model: DP268
To: FCC 15.247.2009

Serial#: 1002879
Issue Date: Sep 17 2010
Page 32 of 73
www.siemic.com.cn

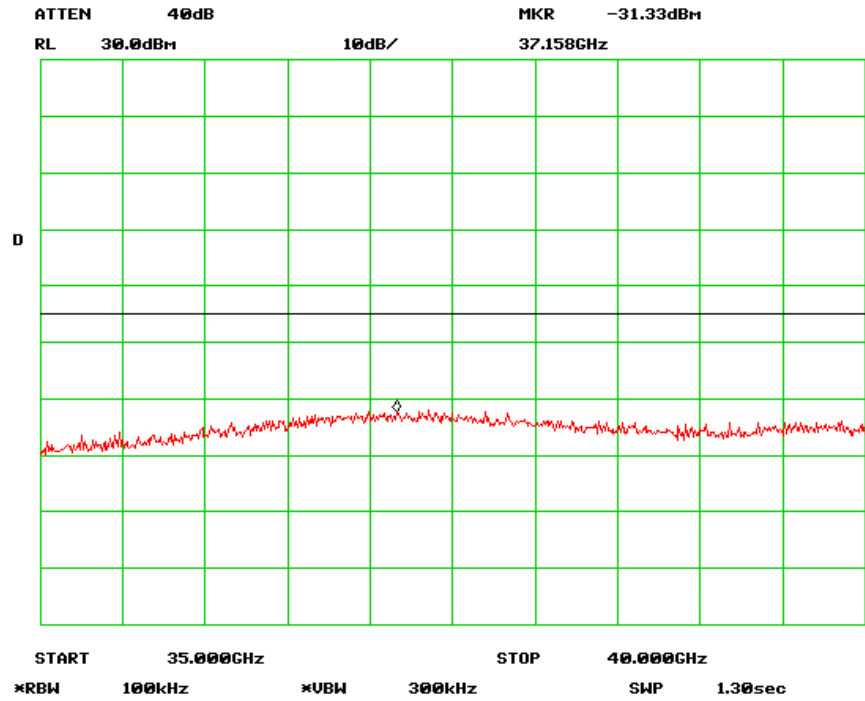



SIEMIC, Inc.

Accessing global markets

Title: RF Test Report for DSRC Road-Side Units
Model: DP268
To: FCC 15.247.2009

Serial#: 1002879
Issue Date: Sep 17 2010
Page: 33 of 73
www.siemec.com.cn

Channel 5845.10MHz

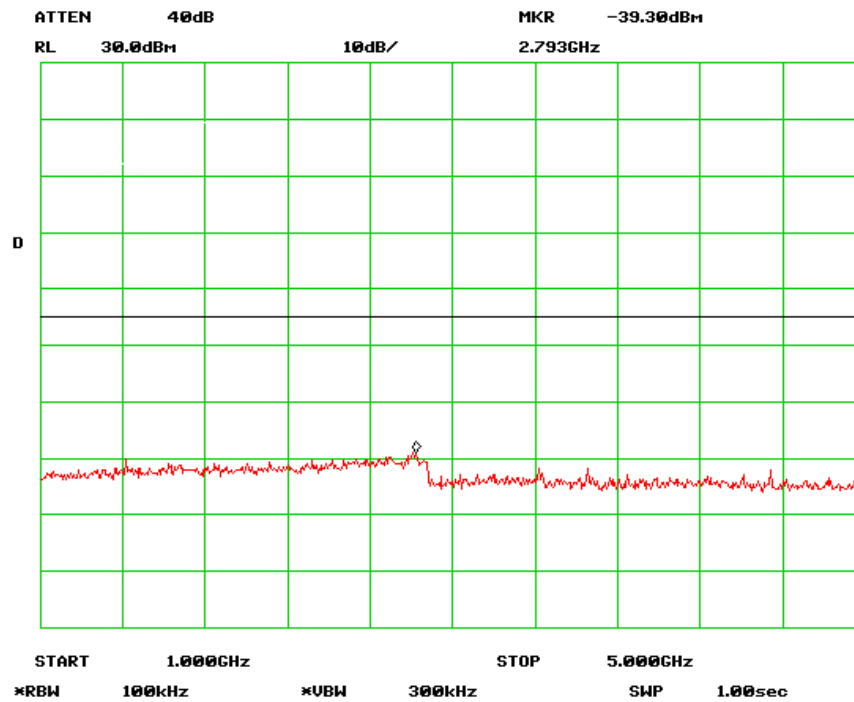
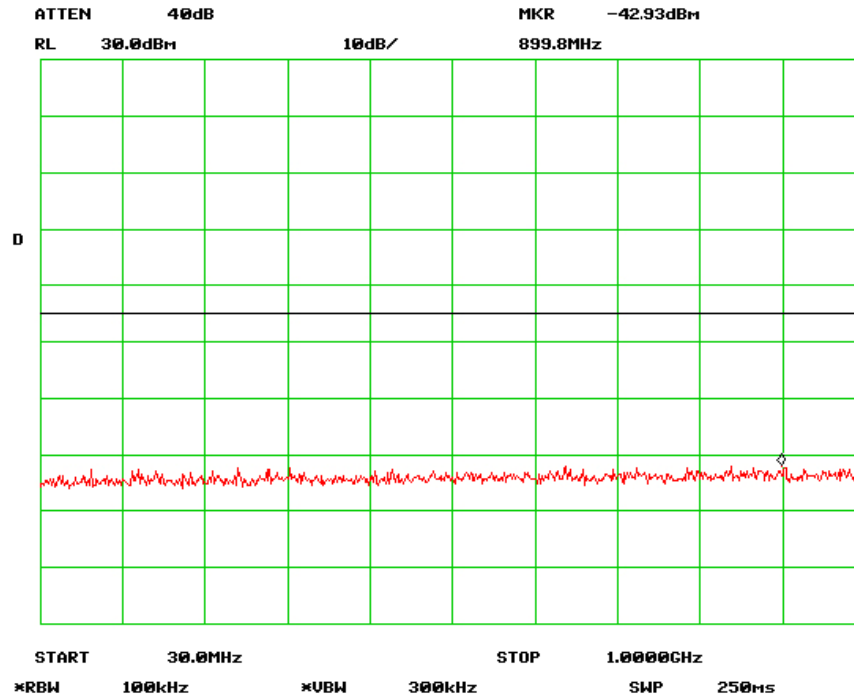



SIEMIC, INC.

Accessing global markets

Title: RF Test Report for DSRC Road-Side Units
Model: DP268
To: FCC 15.247.2009

Serial#: 1002879
Issue Date: Sep 17 2010
Page 34 of 73
www.siemic.com.cn

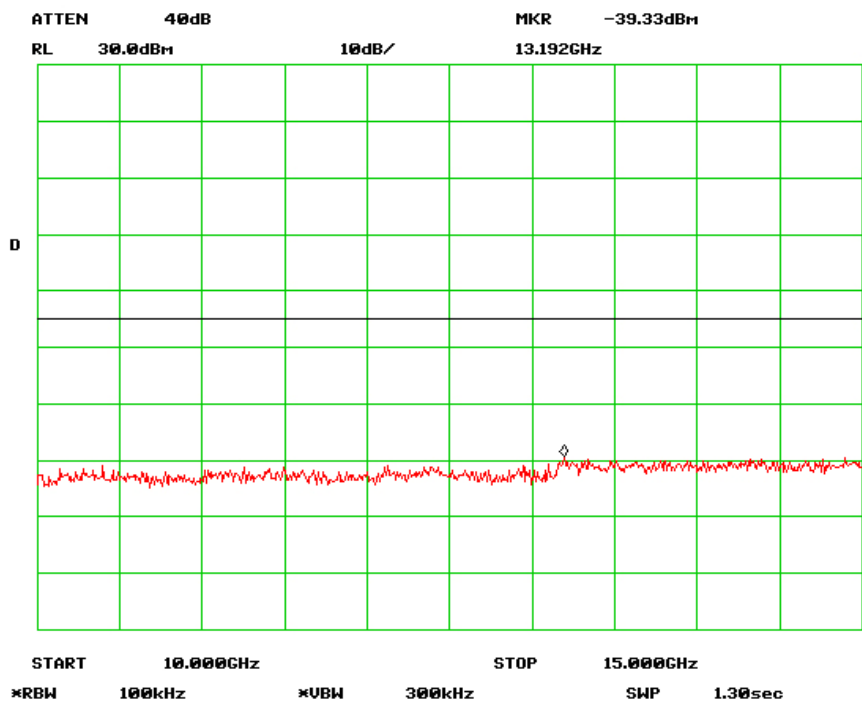
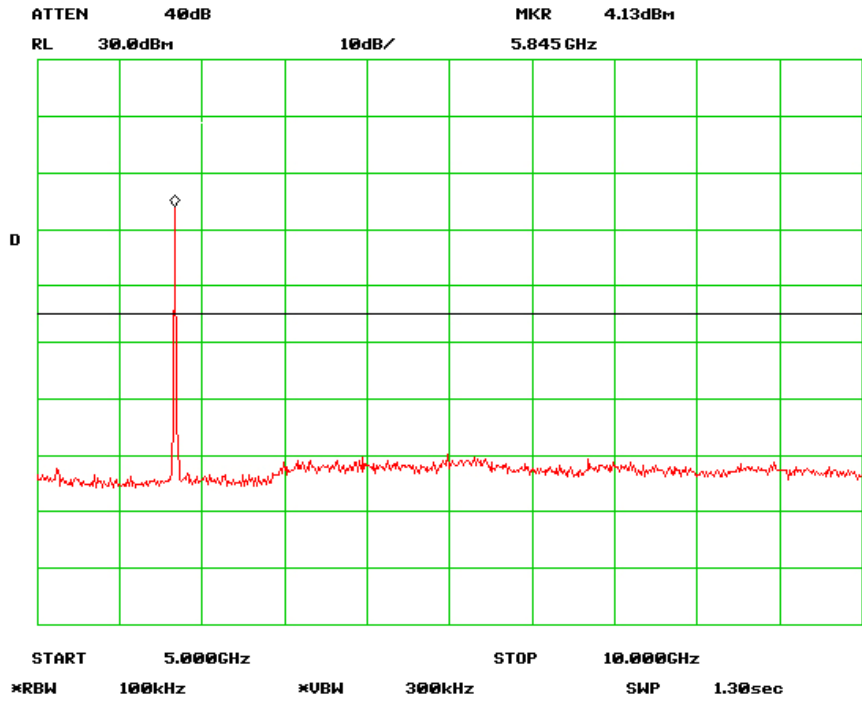



SIEMIC, INC.

Accessing global markets

Title: RF Test Report for DSRC Road-Side Units
Model: DP268
To: FCC 15.247:2009

Serial#: 1002879
Issue Date: Sep 17 2010
Page: 35 of 73
www.siemic.com.cn

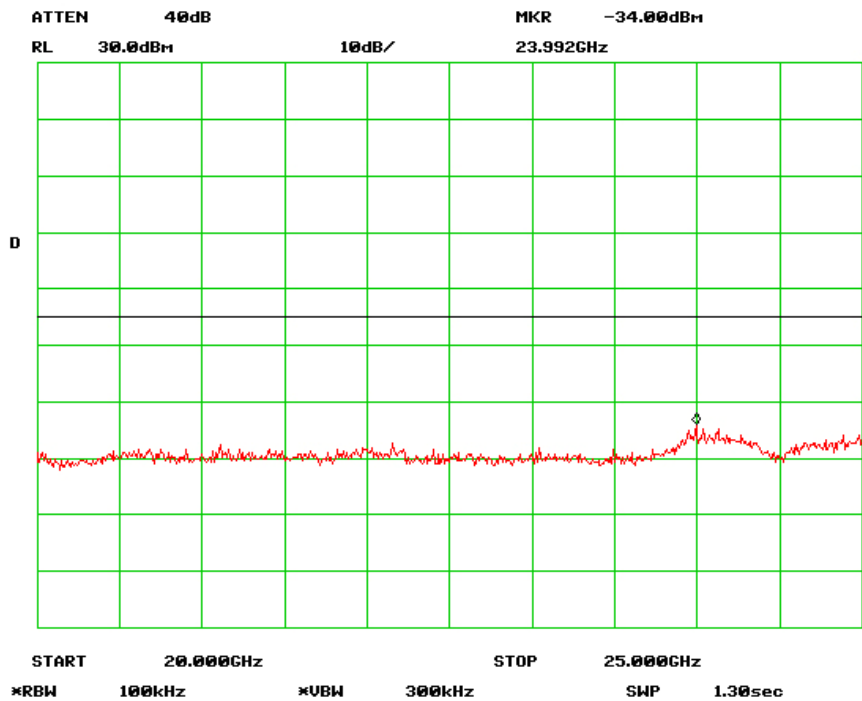
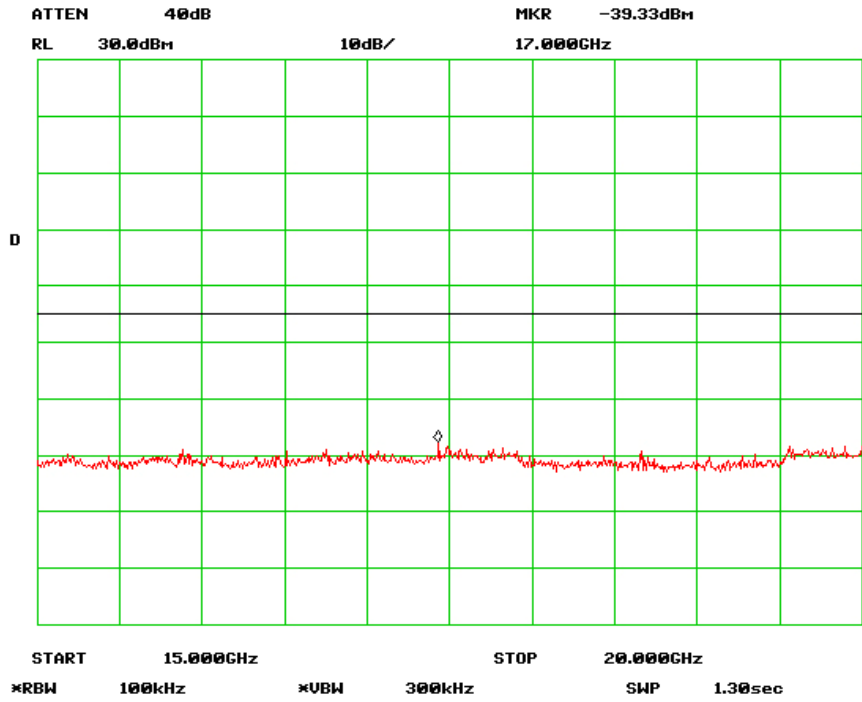



SIEMIC, Inc.

Accessing global markets

Title: RF Test Report for DSRC Road-Side Units
Model: DP268
To: FCC 15.247.2009

Serial#: 1002879
Issue Date: Sep 17 2010
Page 36 of 73
www.siemac.com.cn

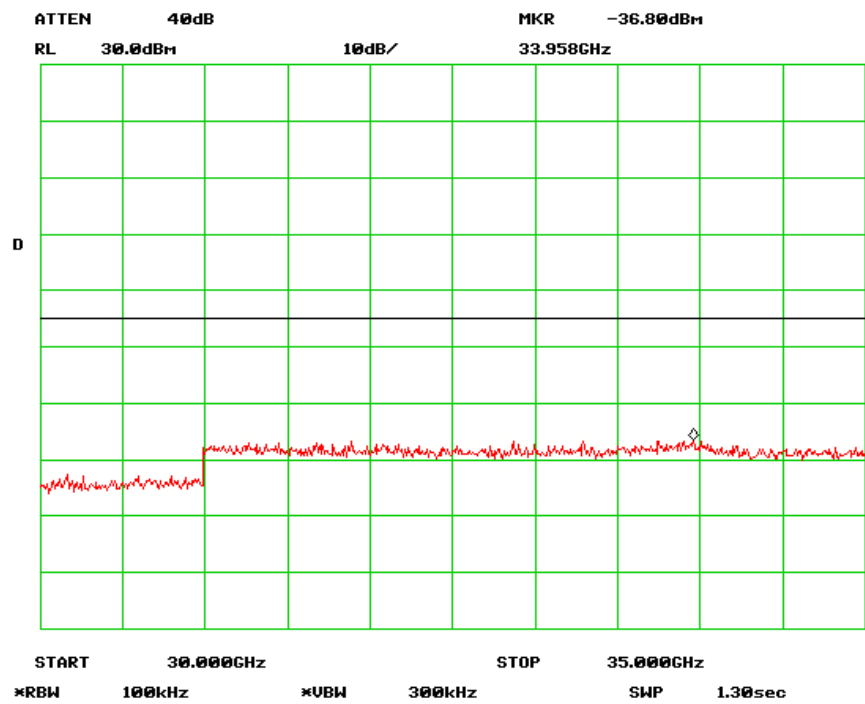
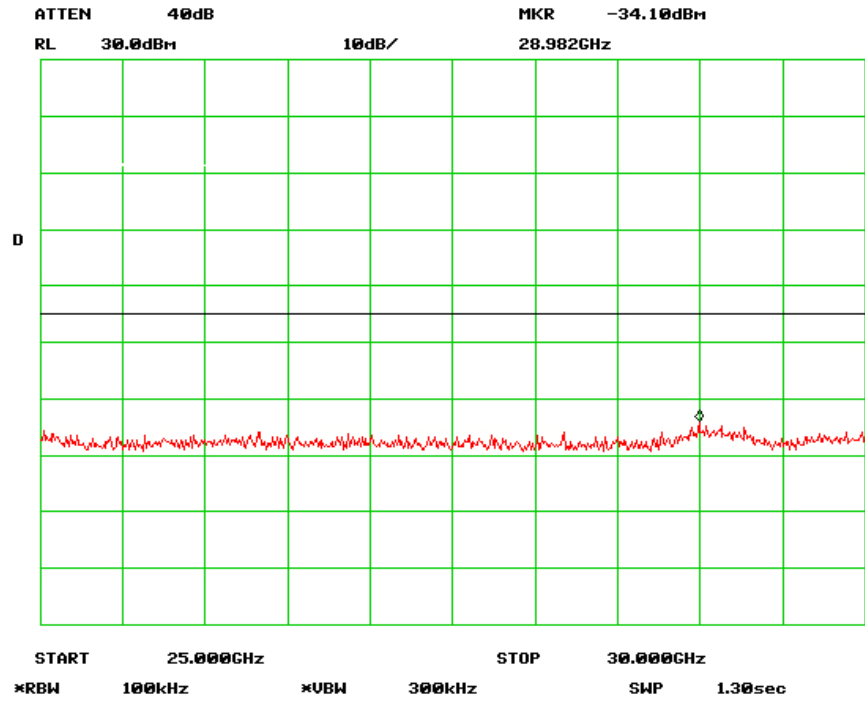



SIEMIC, Inc.

Accessing global markets

Title: RF Test Report for DSRC Road-Side Units
Model: DP268
To: FCC 15.247.2009

Serial#: 1002879
Issue Date: Sep 17 2010
Page 37 of 73
www.sieminc.com.cn

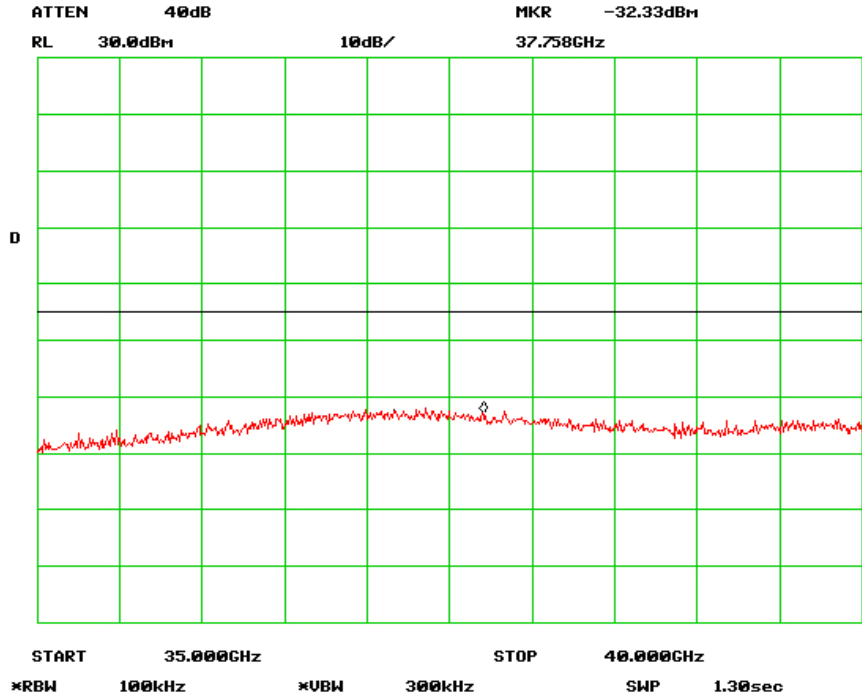

Operating mode: transmitting

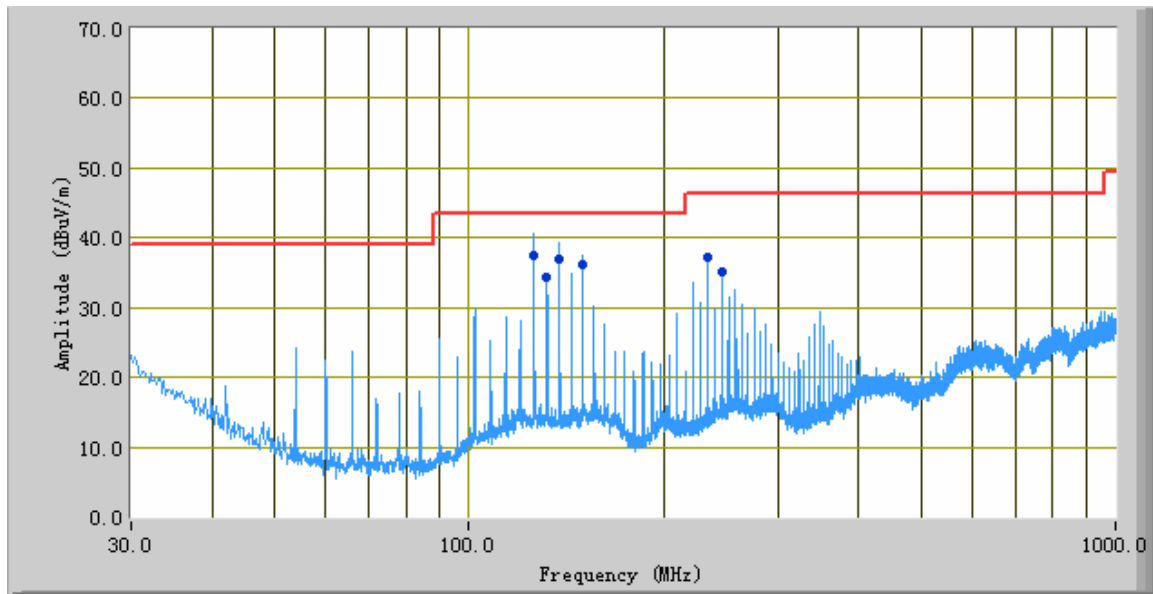

Test Data

Frequency (MHz)	Quasi Peak (dBuV/m)	Azimuth	Polarity(H /V)	Height (cm)	Factors (dB)	Limit (dBuV/m)	Margin (dB)
126.02	37.50	357.00	V	99.00	-31.75	43.52	-6.02
138.02	36.89	358.00	V	118.00	-32.47	43.52	-6.63
150.01	36.13	351.00	H	112.00	-32.27	43.52	-7.39
234.03	37.25	32.00	V	105.00	-32.62	46.44	-9.19
132.02	34.47	214.00	V	152.00	-31.97	43.52	-9.05
246.03	35.25	29.00	V	100.00	-31.30	46.44	-11.19

5.8 Radiated Spurious Emissions > 1GHz & Band Edge

1. All possible modes of operation were investigated. Only the 6 worst case emissions measured, using the correct CISPR detectors, are reported. All other emissions were relatively insignificant.
2. A "-ve" margin indicates a PASS as it refers to the margin present below the limit line at the particular frequency.
3. Radiated Emissions Measurement Uncertainty
All test measurements carried out are traceable to national standards. The uncertainty of the measurement at a confidence level of approximately 95% (in the case where distributions are normal), with a coverage factor of 2, in the range 30MHz – 1GHz & 1GHz above (3m & 10m) is +/-6dB.
4. Environmental Conditions Temperature 23°C
Relative Humidity 50%
Atmospheric Pressure 1019mbar
5. Test date : Sep 11~17 2010
Tested By : Alex Wang

Standard Requirement: The emissions from the Low-power radio-frequency devices shall not exceed the field strength levels specified in the following table and the level of any unwanted emissions shall not exceed the level of the fundamental emission. The tighter limit applies at the band edges.

Test Result:



@ 5750.10MHz @ 3 Meter

Frequency	Direction	Height	Polar	Cable loss	Amplifier	Corrected Reading	15.247/15.209	15.247/15.209	
GHz	Degree	Meter	H / V	(dB)	(dB)	(dBuV/m)	Limit (dBuV/m)	Margin	Comments
11.5002	119.00	1.27	v	7.15	55.00	62.22	74.00	-11.78	Peak
11.5002	125.00	1.10	h	7.15	55.00	60.15	74.00	-13.85	Peak
11.5002	122.00	1.10	v	7.15	55.00	52.13	54.00	-1.87	Ave
11.5002	158.00	1.30	h	7.15	55.00	51.26	54.00	-2.74	Ave

@ 5800.10MHz @ 3 Meter

Frequency	Direction	Height	Polar	Cable loss	Amplifier	Corrected Reading	15.247/15.209	15.247/15.209	
GHz	Degree	Meter	H / V	(dB)	(dB)	(dBuV/m)	Limit (dBuV/m)	Margin	Comments
11.6002	129.00	1.77	v	7.15	55.00	61.22	74.00	-12.78	Peak
11.6002	123.00	1.20	h	7.15	55.00	60.11	74.00	-13.89	Peak
11.6002	114.00	2.20	v	7.15	55.00	50.14	54.00	-3.86	Ave
11.6002	138.00	1.30	h	7.15	55.00	50.11	54.00	-3.89	Ave

@ 5845.10MHz @ 3 Meter

Frequency	Direction	Height	Polar	Cable loss	Amplifier	Corrected Reading	15.247/15.209	15.247/15.209	
GHz	Degree	Meter	H / V	(dB)	(dB)	(dBuV/m)	Limit (dBuV/m)	Margin	Comments
11.6902	109.00	1.47	v	7.15	55.00	60.25	74.00	-13.75	Peak
11.6902	155.00	1.20	h	7.15	55.00	60.22	74.00	-13.78	Peak
11.6902	142.00	1.30	v	7.15	55.00	51.11	54.00	-2.89	Ave
11.6902	148.00	1.40	h	7.15	55.00	51.41	54.00	-2.59	Ave

Emission was scanned up to 40GHz.



SIEMIC, INC.

Accessing global markets

Title: RF Test Report for DSRC Road-Side Units
Model: DP268
To: FCC 15.247:2009

Serial#: 1002879
Issue Date: Sep 17 2010
Page 42 of 73
www.siemec.com.cn

Band Edge

Channel	Polarity	Detector	Frequency	Result	Limit	Margin
Low Channel	V	Peak	5725	38.56	74	-35.44
Low Channel	H	Peak	5725	44.12	74	-29.88
Low Channel	V	Avg	5725	25.12	54	-28.88
Low Channel	H	Avg	5725	25.71	54	-28.29

Channel	Polarity	Detector	Frequency	Result	Limit	Margin
High Channel	V	Peak	5850	41.23	74	-32.77
High Channel	H	Peak	5850	46.67	74	-27.33
High Channel	V	Avg	5850	28.15	54	-25.85
High Channel	H	Avg	5850	32.35	54	-21.65

Annex A. TEST INSTRUMENT & METHOD

Annex A.i. TEST INSTRUMENTATION & GENERAL PROCEDURES

Instrument	Manufacturer	Model	CAL Due Date
Spectrum Analyzer	HP	8564 E	2011.04.26
EMI Receiver	Rohde & Schwarz	ESPI 3	2011.02.19
Antenna (30MHz~2GHz)	Sunol Sciences	JB1	2010.10.04
Horn Antenna (1~18GHz)	A-INFOMW	JXTXLB-10180	2010.11.18
Horn Antenna (1~18GHz)	N/A	N/A	2010.10.04
Pre-Amplifier(0.01 ~ 1.3GHz)	HP	8447F	2011.04.24
Pre-Amplifier(0.1 ~ 18GHz)	MITEQ	AMF-7D-00101800-30- 10P	2011.03.05
Horn Antenna (18~40GHz)	Com Power	AH-840	2011.05.21
Microwave Pre-Amp (18~40GHz)	Com Power	PA-840	2011.05.21

Annex A.ii. CONDUCTED EMISSIONS TEST DESCRIPTION

Test Set-up

1. The EUT and supporting equipment were set up in accordance with the requirements of the standard on top of a 1.5m x 1m x 0.8m high, non-metallic table, as shown in Annex B.
2. The power supply for the EUT was fed through a 50Ω/50μH EUT LISN, connected to filtered mains.
3. The RF OUT of the EUT LISN was connected to the EMI test receiver via a low-loss coaxial cable.
4. All other supporting equipments were powered separately from another main supply.

Test Method

1. The EUT was switched on and allowed to warm up to its normal operating condition.
2. A scan was made on the NEUTRAL line (for AC mains) or Earth line (for DC power) over the required frequency range using an EMI test receiver.
3. High peaks, relative to the limit line, were then selected.
4. The EMI test receiver was then tuned to the selected frequencies and the necessary measurements made with a receiver bandwidth setting of 10 KHz. For FCC tests, only Quasi-peak measurements were made; while for CISPR/EN tests, both Quasi-peak and Average measurements were made.
5. Steps 2 to 4 were then repeated for the LIVE line (for AC mains) or DC line (for DC power).

Sample Calculation Example

At 20 MHz	limit = 250 μV = 47.96 dBμV
Transducer factor of LISN, pulse limiter & cable loss at 20 MHz = 11.20 dB	
Q-P reading obtained directly from EMI Receiver = 40.00 dBμV (Calibrated for system losses)	
Therefore, Q-P margin = 47.96 – 40.00 = 7.96	i.e. 7.96 dB below limit

Annex A. iii RADIATED EMISSIONS TEST DESCRIPTION

EUT Characterisation

EUT characterisation, over the frequency range from 30MHz to 10th Harmonic , was done in order to minimise radiated emissions testing time while still maintaining high confidence in the test results.

The EUT was placed in the chamber, at a height of about 0.8m on a turntable. Its radiated emissions frequency profile was observed, using a spectrum analyzer /receiver with the appropriate broadband antenna placed 3m away from the EUT. Radiated emissions from the EUT were maximised by rotating the turntable manually, changing the antenna polarisation and manipulating the EUT cables while observing the frequency profile on the spectrum analyzer / receiver. Frequency points at which maximum emissions occurred, clock frequencies and operating frequencies were then noted for the formal radiated emissions test at the Open Area Test Site (OATS).

Test Set-up

1. The EUT and supporting equipment were set up in accordance with the requirements of the standard on top of a 1.5m X 1.0m X 0.8m high, non-metallic table.
2. The filtered power supply for the EUT and supporting equipment were tapped from the appropriate power sockets located on the turntable.
3. The relevant broadband antenna was set at the required test distance away from the EUT and supporting equipment boundary.

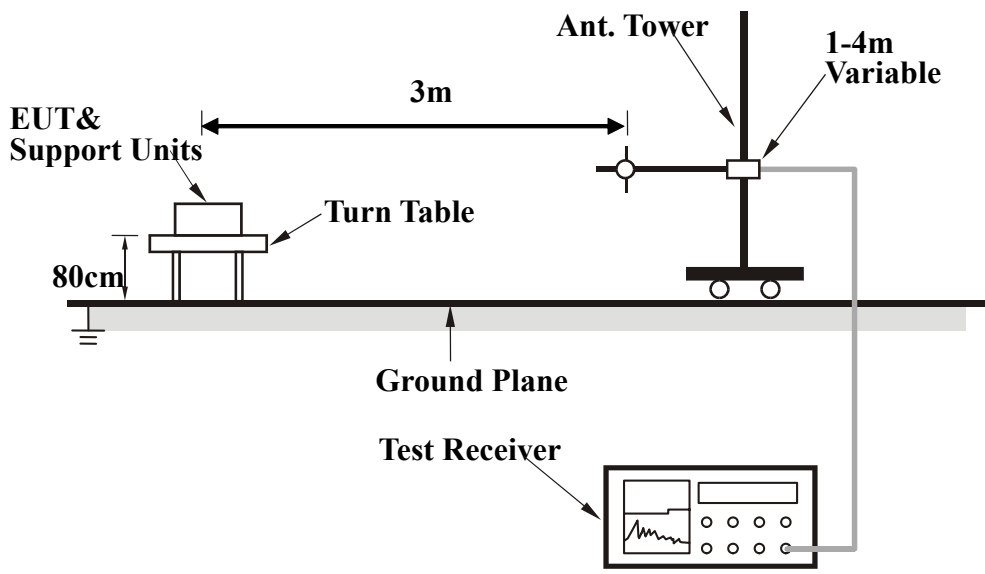

Test Method

The following procedure was performed to determine the maximum emission axis of EUT:

1. With the receiving antenna is H polarization, rotate the EUT in turns with three orthogonal axes to determine the axis of maximum emission.
2. With the receiving antenna is V polarization, rotate the EUT in turns with three orthogonal axes to determine the axis of maximum emission.
3. Compare the results derived from above two steps. So, the axis of maximum emission from EUT was determined and the configuration was used to perform the final measurement.

Final Radiated Emission Measurement

1. Setup the configuration according to figure 1. Turn on EUT and make sure that it is in normal function.
2. For emission frequencies measured below 1 GHz, a pre-scan is performed in a shielded chamber to determine the accurate frequencies of higher emissions will be checked on a open test site. As the same purpose, for emission frequencies measured above 1 GHz, a pre-scan also be performed with a 1 meter measuring distance before final test.
3. For emission frequencies measured below and above 1 GHz, set the spectrum analyzer on a 100 kHz and 1 MHz resolution bandwidth respectively for each frequency measured in step 2.
4. The search antenna is to be raised and lowered over a range from 1 to 4 meters in horizontally polarized orientation. Position the highness when the highest value is indicated on spectrum analyzer, then change the orientation of EUT on test table over a range from 0 ° to 360 ° with a speed as slow as possible, and keep the azimuth that highest emission is indicated on the spectrum analyzer. Vary the antenna position again and record the highest value as a final reading.
5. Repeat step 4 until all frequencies need to be measured were complete.
6. Repeat step 5 with search antenna in vertical polarized orientations.

During the radiated emission test, the Spectrum Analyzer was set with the following configurations:

Frequency Band (MHz)	Function	Resolution bandwidth	Video Bandwidth
30 to 1000	Peak	100 kHz	100 kHz
Above 1000	Peak	1 MHz	1 MHz
	Average	1 MHz	10 Hz

Sample Calculation Example

The field strength is calculated by adding the Antenna Factor and Cable Factor, and subtracting the Amplifier Gain (if any) from the measured reading. For the limit is employed average value, therefore the peak value can be transferred to average value by subtracting the duty factor. The basic equation with a sample calculation is as follows:

$$\text{Peak} = \text{Reading} + \text{Corrected Factor}$$

where

$$\text{Corr. Factor} = \text{Antenna Factor} + \text{Cable Factor} - \text{Amplifier Gain (if any)}$$

And the average value is

$$\text{Average} = \text{Peak Value} + \text{Duty Factor or}$$

$$\text{Set RBW} = 1\text{MHz, VBW} = 10\text{Hz.}$$

Note :

If the measured frequencies are fall in the restricted frequency band, the limit employed must be quasi peak value when frequencies are below or equal to 1 GHz. And the measuring instrument is set to quasi peak detector function.

Annex B. EUT AND TEST SETUP PHOTOGRAPHS

Annex B.i. Photograph : EUT Photo





SIEMIC, INC.

Accessing global markets

Title: RF Test Report for DSRC Road-Side Units
Model: DP268
To: FCC 15.247:2009

Serial#: 1002879
Issue Date: Sep 17 2010
Page: 48 of 73
www.siemac.com.cn



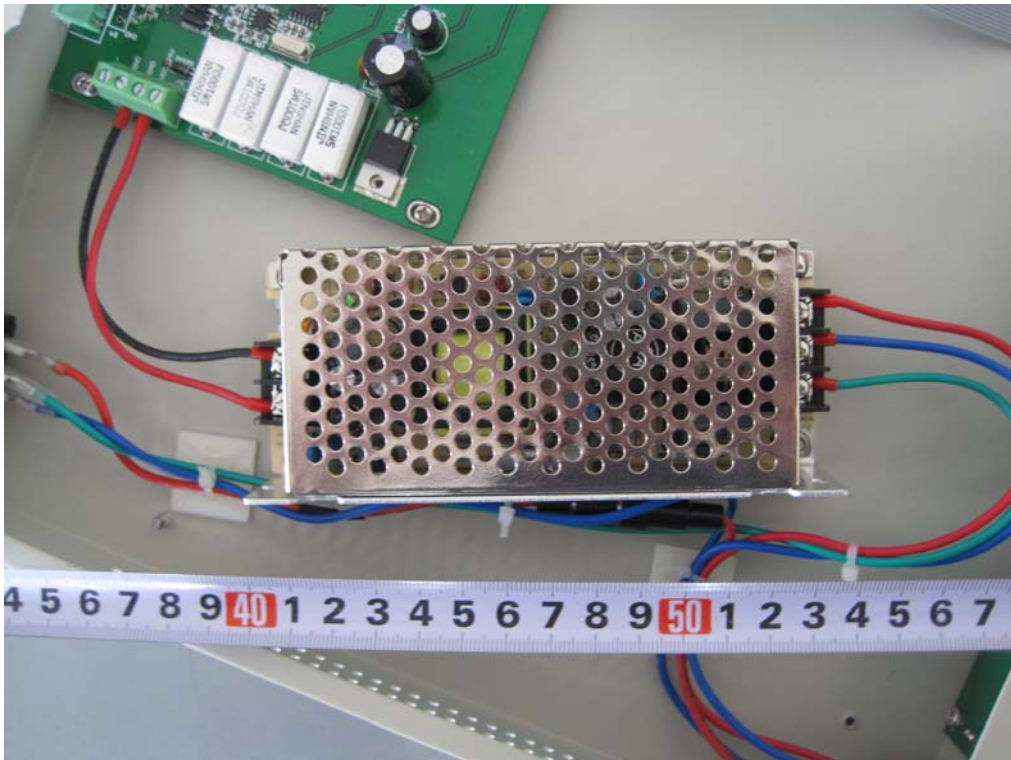
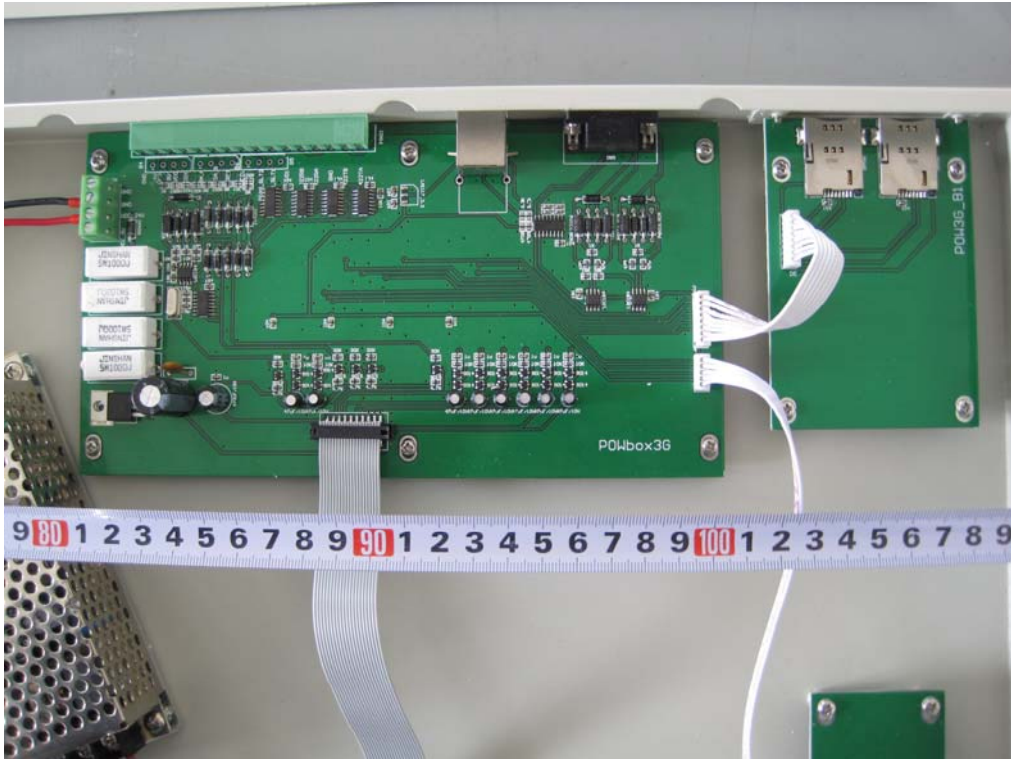



SIEMIC, INC.

Accessing global markets

Title: RF Test Report for DSRC Road-Side Units
Model: DP268
To: FCC 15.247:2009

Serial#: 1002879
Issue Date: Sep 17 2010
Page: 50 of 73
www.siemac.com.cn

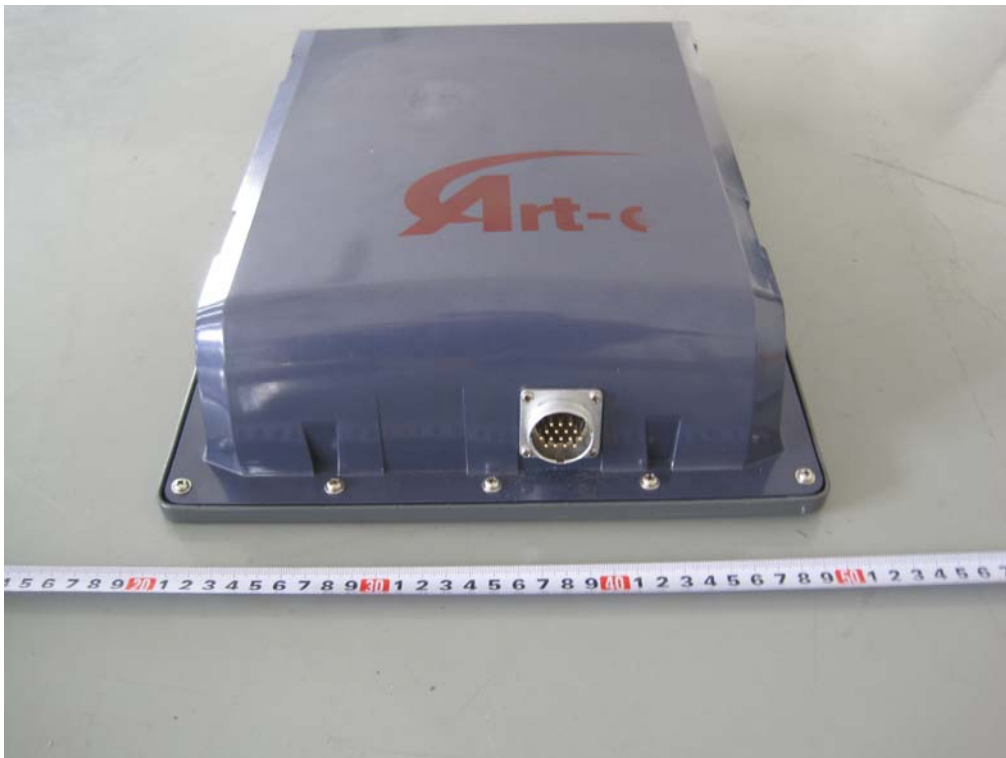
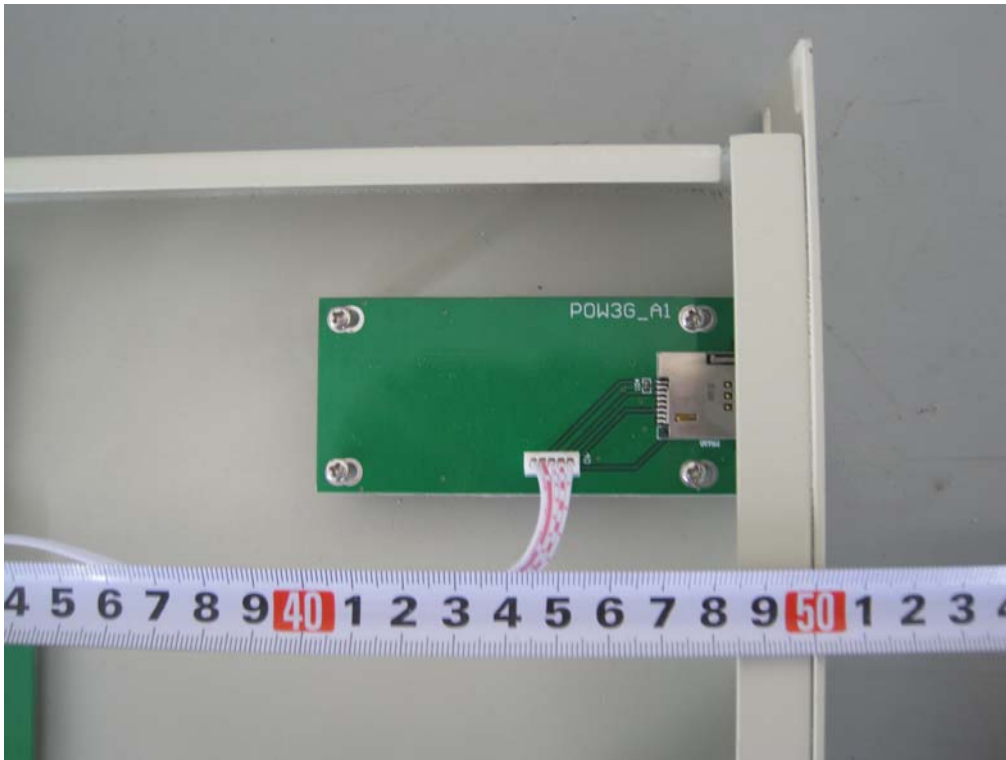



SIEMIC, Inc.

Accessing global markets

Title: RF Test Report for DSRC Road-Side Units
Model: DP268
To: FCC 15.247:2009

Serial#: 1002879
Issue Date: Sep 17 2010
Page 51 of 73
www.siemic.com.cn

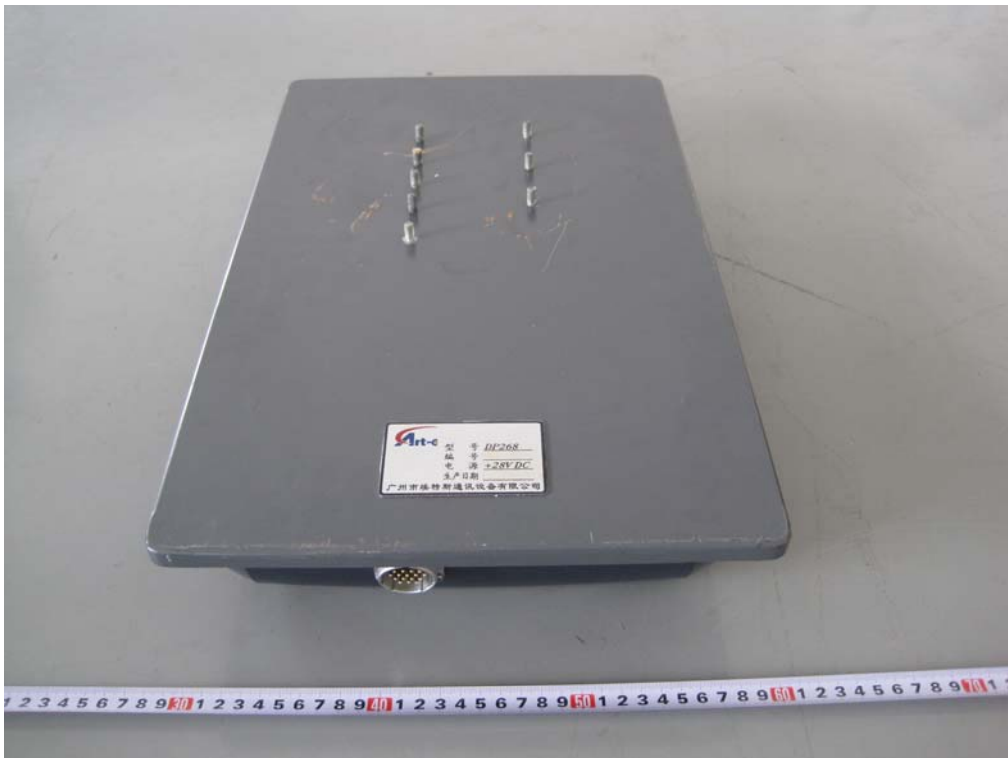
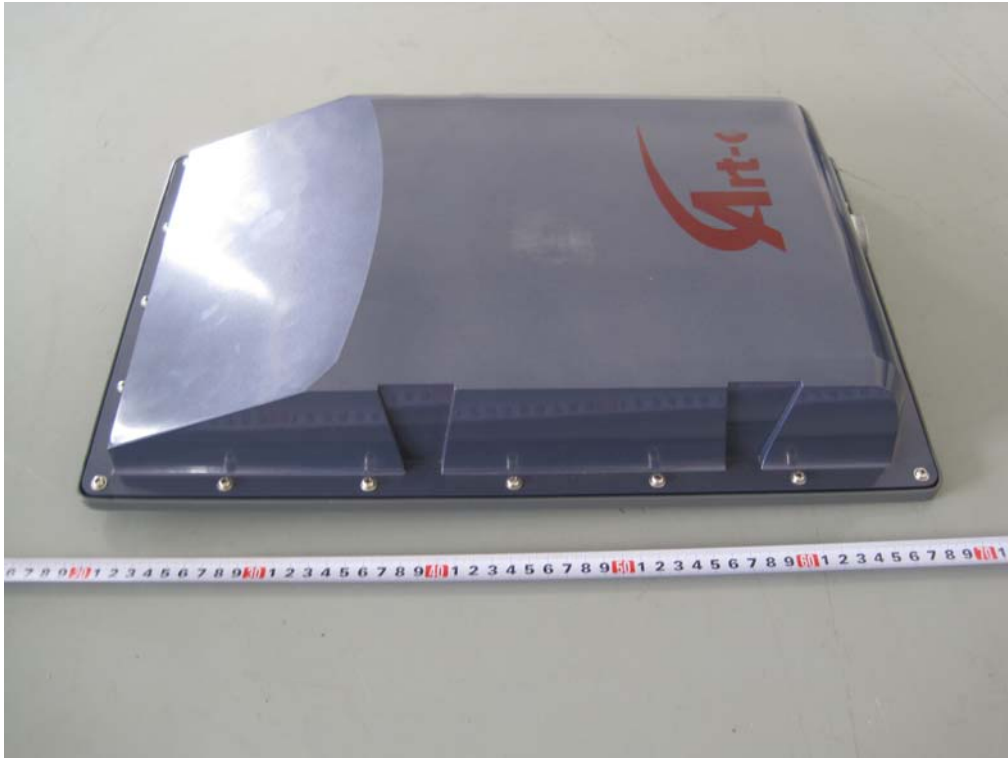



SIEMIC, INC.

Accessing global markets

Title: RF Test Report for DSRC Road-Side Units
Model: DP268
To: FCC 15.247:2009

Serial#: 1002879
Issue Date: Sep 17 2010
Page 52 of 73
www.siemec.com.cn

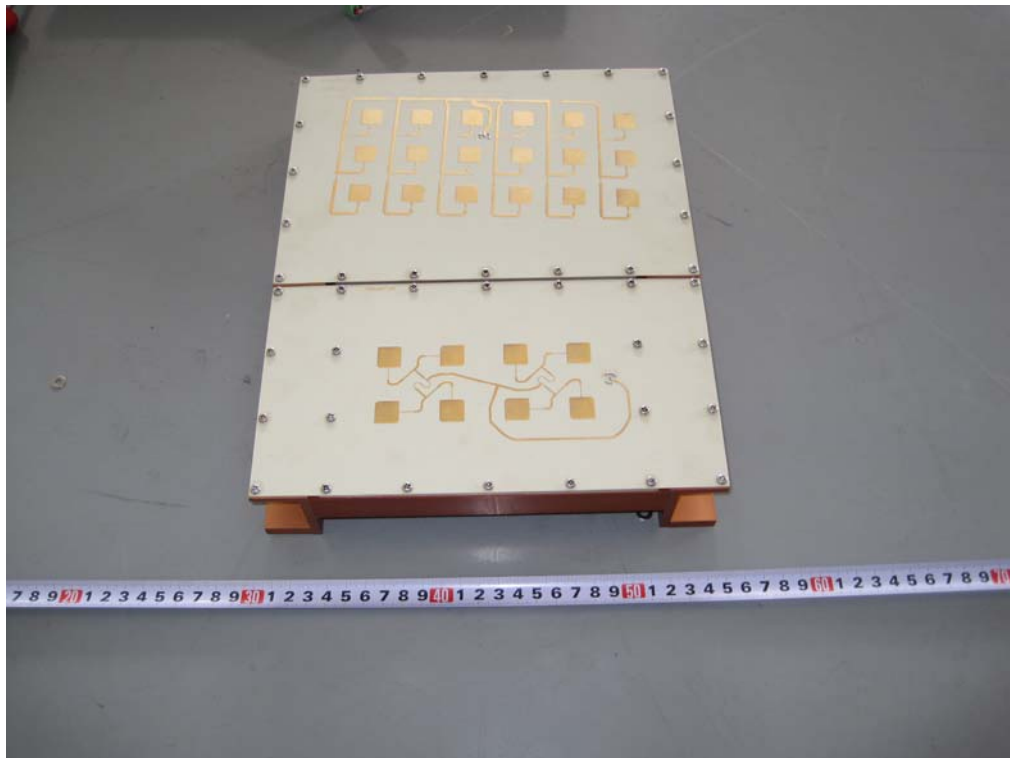



SIEMIC, INC.

Accessing global markets

Title: RF Test Report for DSRC Road-Side Units
Model: DP268
To: FCC 15.247:2009

Serial#: 1002879
Issue Date: Sep 17 2010
Page 53 of 73
www.siemac.com.cn

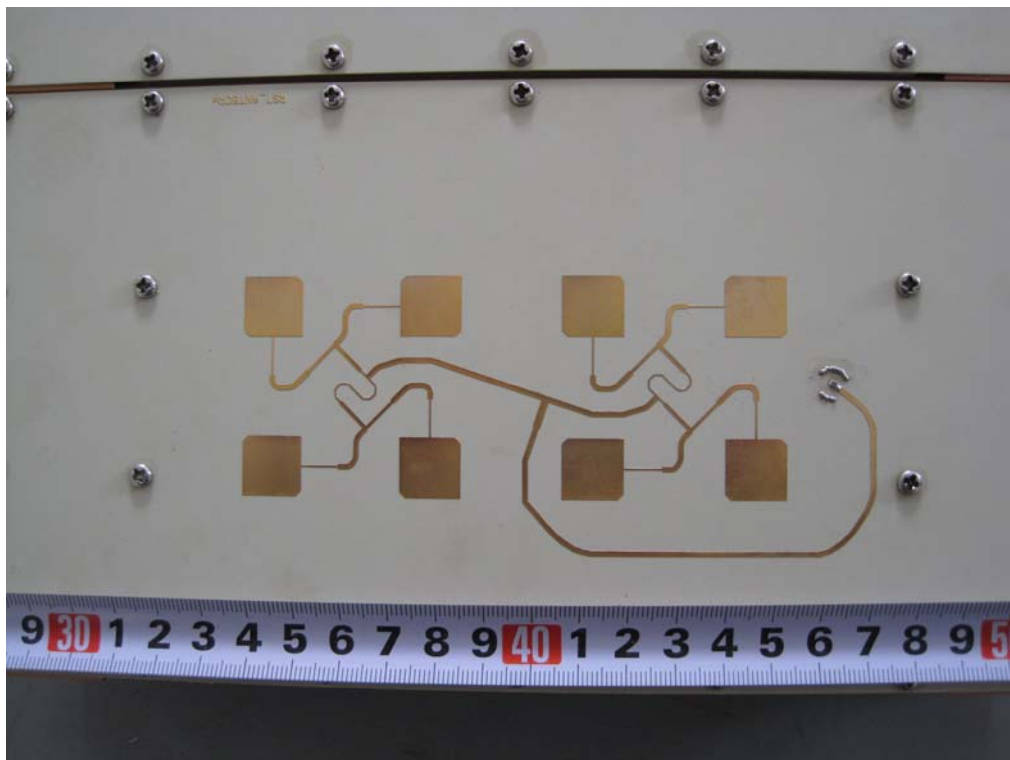
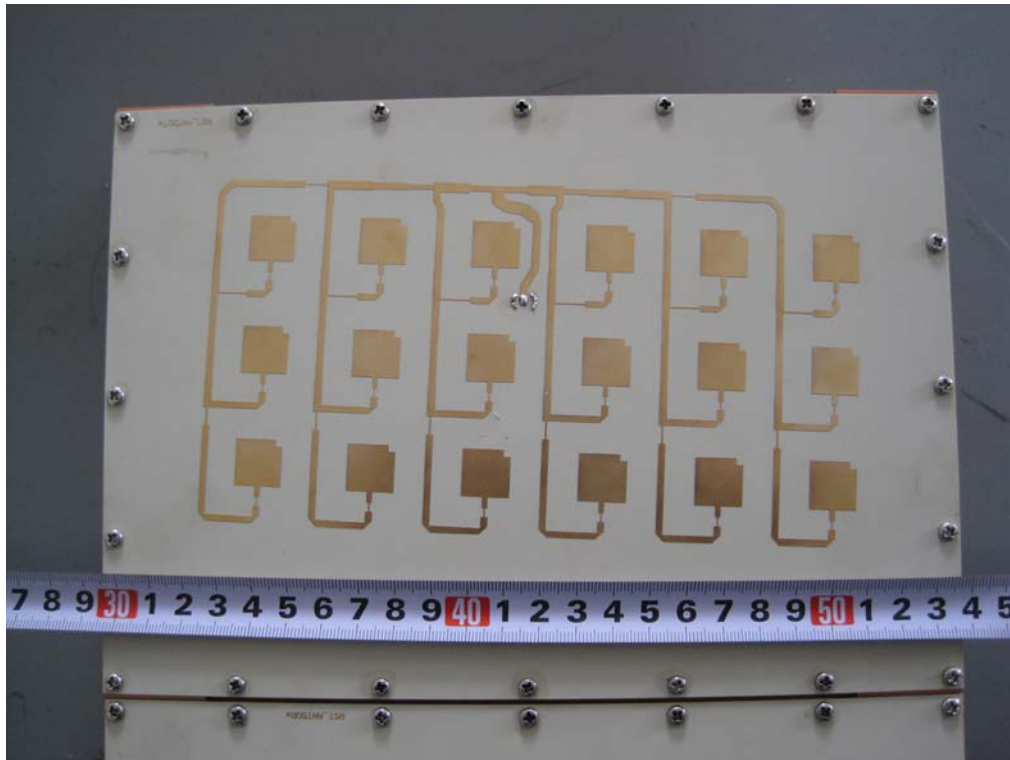



SIEMIC, INC.

Accessing global markets

Title: RF Test Report for DSRC Road-Side Units
Model: DP268
To: FCC 15.247:2009

Serial#: 1002879
Issue Date: Sep 17 2010
Page 54 of 73
www.siemac.com.cn

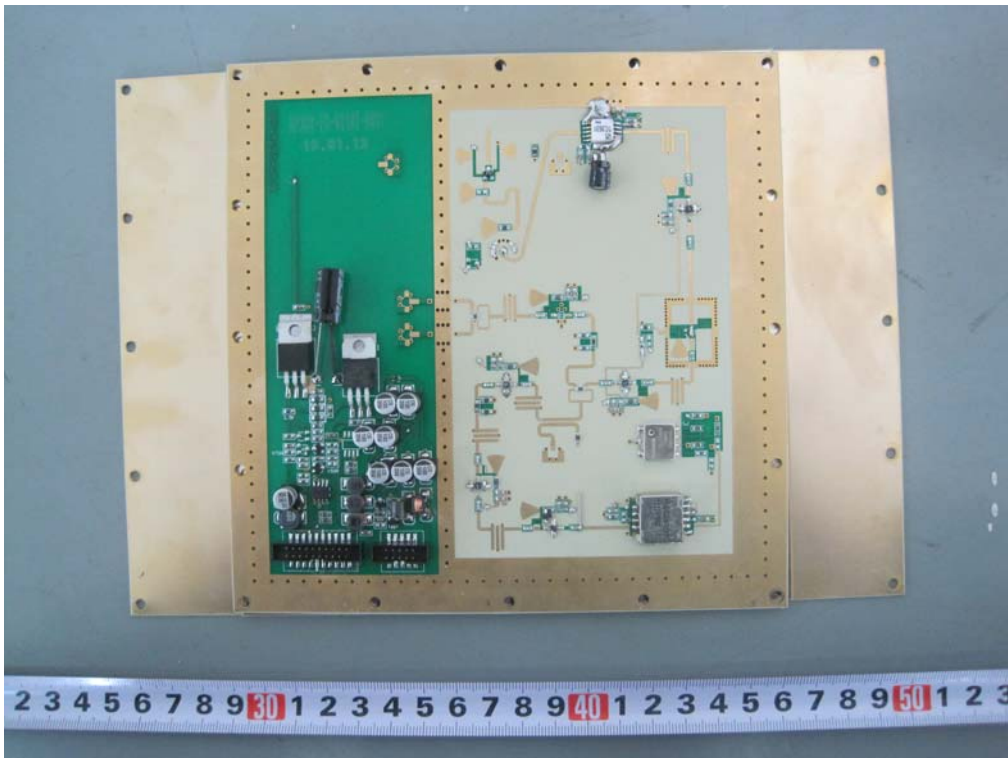
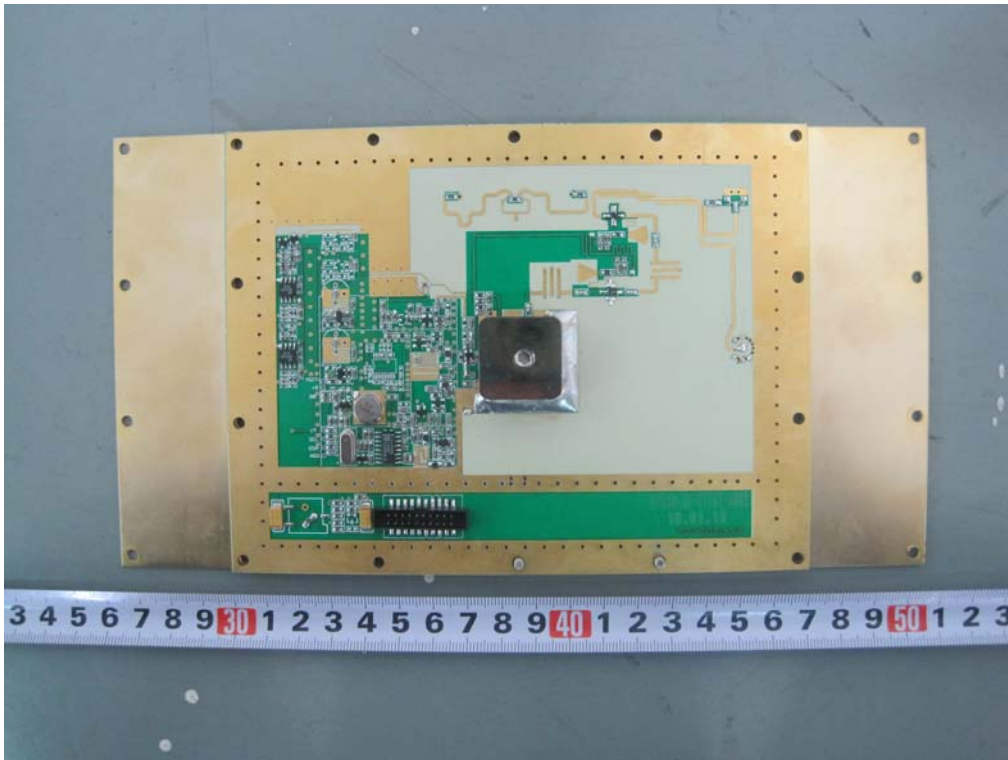

Annex B.ii Photograph 4: Test Setup Photo



Conducted Emissions Test Setup Front View



Conducted Emissions Test Setup Side View

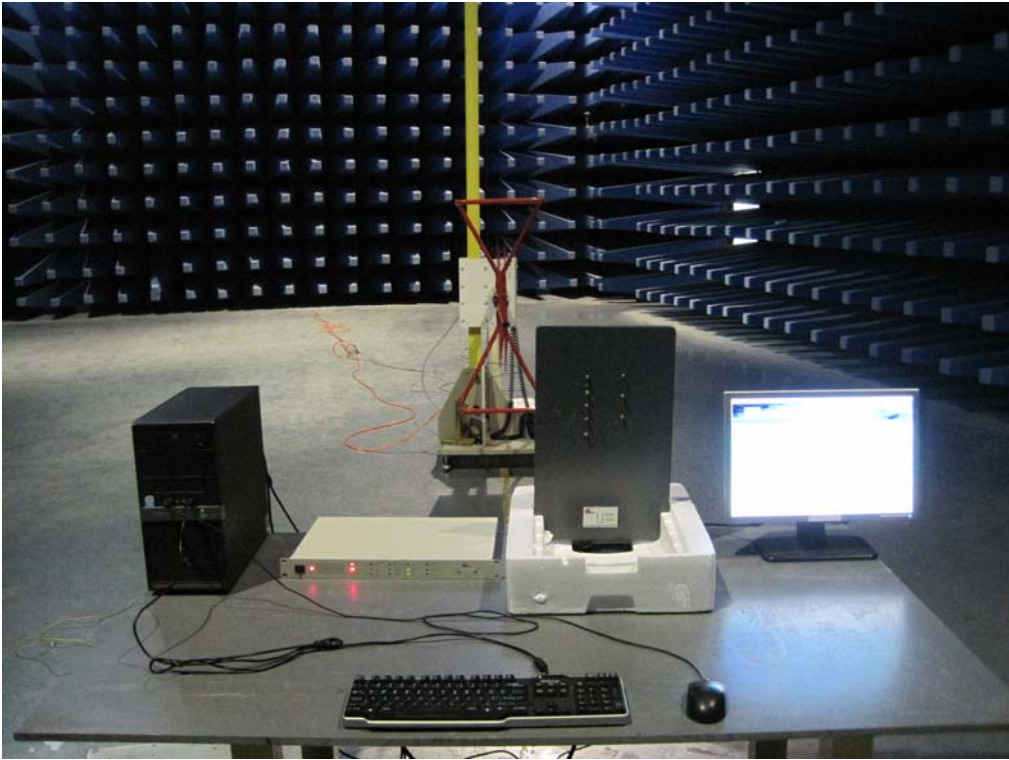

Radiated Spurious Emissions Test Setup (30MHz-1GHz)

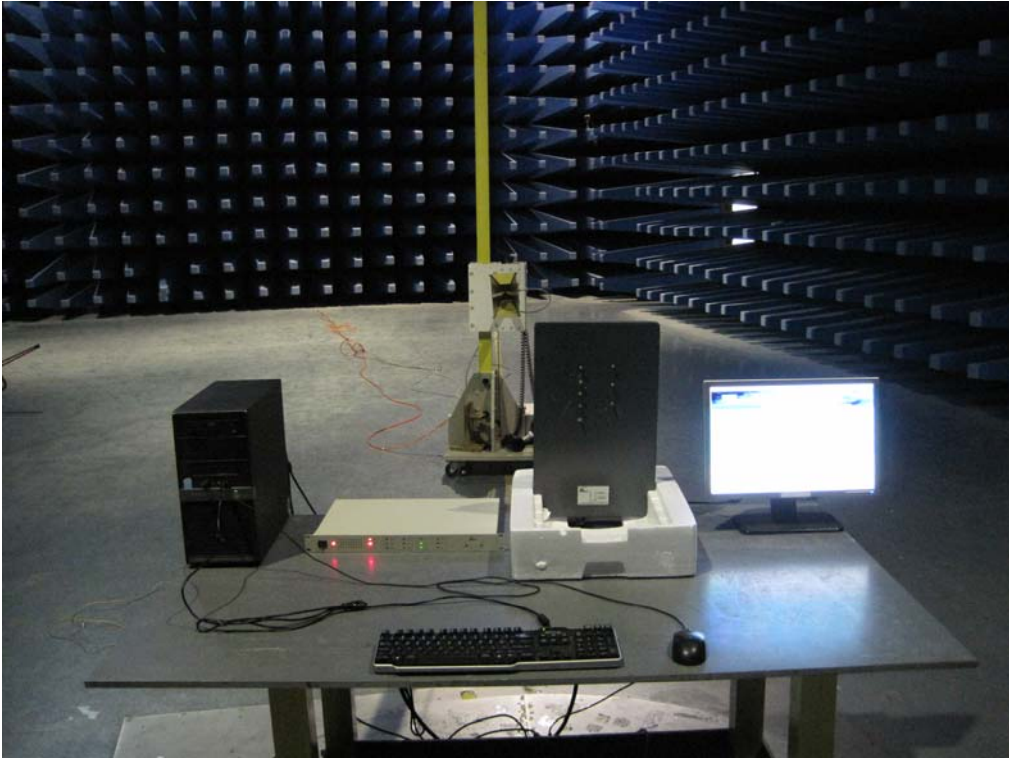

Radiated Spurious Emissions Test Setup (Above 1GHz)

Annex C. TEST SETUP AND SUPPORTING EQUIPMENT

EUT TEST CONDITIONS

Annex C. i. SUPPORTING EQUIPMENT DESCRIPTION

The following is a description of supporting equipment and details of cables used with the EUT.

Equipment Description (Including Brand Name)	Model & Serial Number	Cable Description (List Length, Type & Purpose)
Dell Monitor	SE198WFPf	VGA Cable 3m
Logitech Keyboard	Y-SU61	PS/2 Cable 2m
Logitech Mouse	N/A	PS/2 Cable 1m
Dell PC	DELL	Cable 1m

Block Configuration Diagram for Radiated Emission

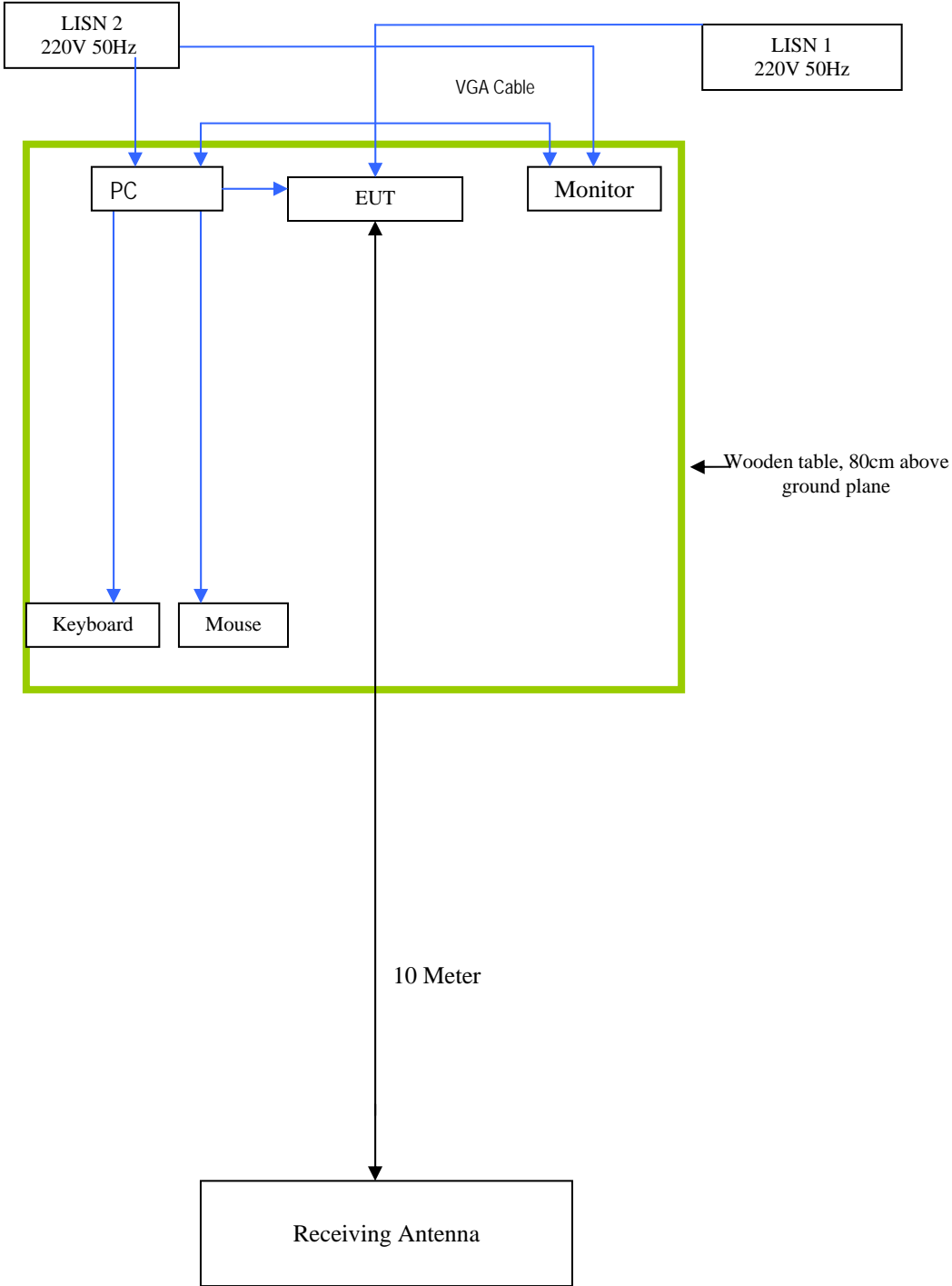

Block Configuration Diagram for Conducted Emission

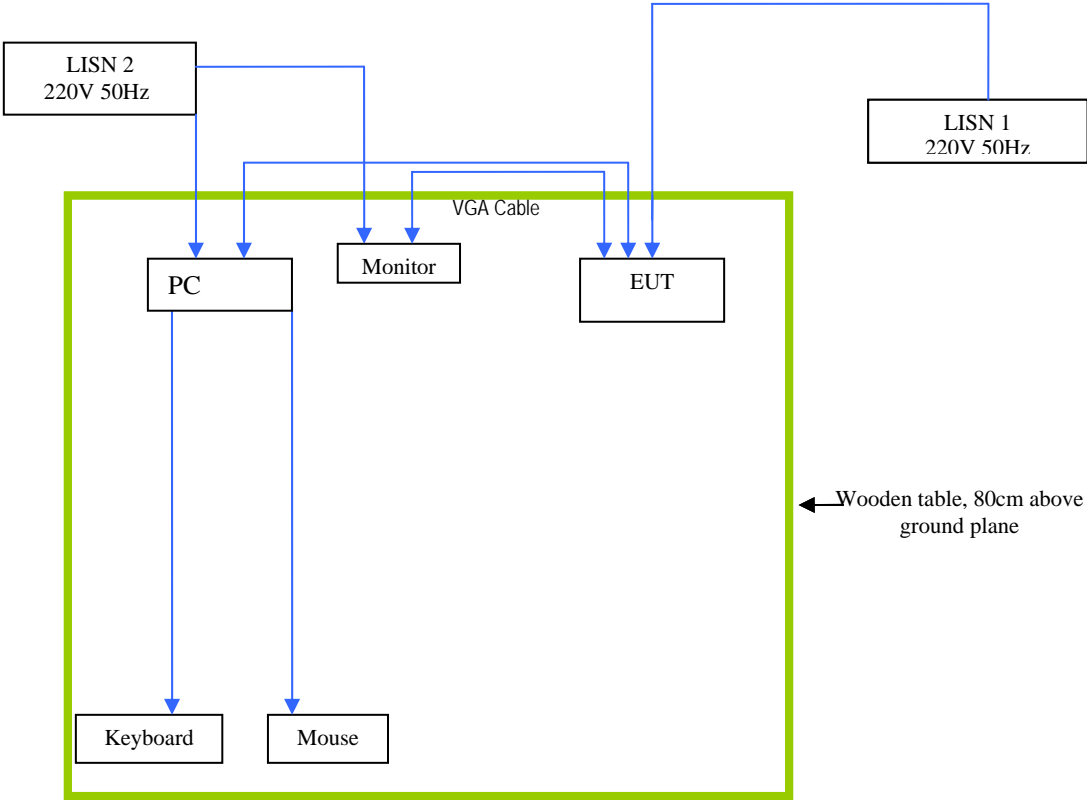

Annex C.ii. EUT OPERATING CONDITIONS

The following is the description of how the EUT is exercised during testing.

Test	Description Of Operation
Emissions	EUT was set to tansmit at highest RF power.



SIEMIC, INC.

Accessing global markets

Title: RF Test Report for DSRC Road-Side Units
Model: DP268
To: FCC 15.247.2009

Serial#: 1002879
Issue Date: Sep 17 2010
Page 61 of 73
www.siemac.com.cn

Annex D. USER MANUAL / BLOCK DIAGRAM / SCHEMATICS / PART LIST

Please see attachment

Annex E. SIEMIC ACCREDITATION CERTIFICATES

SIEMIC ACREDITATION DETAILS: A2LA Certificate Number: 2742.01

		THE AMERICAN ASSOCIATION FOR LABORATORY ACCREDITATION
ACCREDITED LABORATORY		
A2LA has accredited SIEMIC LABORATORIES San Jose, CA for technical competence in the field of Electrical Testing		
<small>This laboratory is accredited in accordance with the recognized International Standard ISO/IEC 17025:2005 <i>General Requirements for the Competence of Testing and Calibration Laboratories</i>. This accreditation demonstrates technical competence for a defined scope and the operation of a laboratory quality management system (refer to joint ISO-ILAC-IAF Communiqué dated 18 June 2005).</small>		
	Presented this 11th day of July 2008.  President For the Accreditation Council Certificate Number 2742.01 Valid to September 30, 2010	
<small>For the tests or types of tests to which this accreditation applies, please refer to the laboratory's Electrical Scope of Accreditation.</small>		

	THE AMERICAN ASSOCIATION FOR LABORATORY ACCREDITATION
ACCREDITED PRODUCT CERTIFICATION BODY	
A2LA has accredited SIEMIC INC. San Jose, CA for technical competence as a Product Certification Body	
<small>This product certification body is accredited in accordance with the recognized International Standard ISO/IEC Guide 65:1996 <i>General requirements for bodies operating product certification systems</i>. This accreditation demonstrates technical competence for a defined scope and the operation of a quality management system for a Telecommunications Certification Body (TCB) meeting FCC (U.S.), IDA (Singapore) and IC (Canada) requirements.</small>	
	Presented this 9 th day of January 2009.  President For the Accreditation Council Certificate Number: 2742.02 Valid to: September 30, 2010
<small>For the product certification schemes to which this accreditation applies, please refer to the certification body's Scope of Accreditation.</small>	



SIEMIC, INC.

Accessing global markets

Title: RF Test Report for DSRC Road-Side Units
Model: DP268
To: FCC 15.247:2009

Serial#: 1002879
Issue Date: Sep 17 2010
Page: 63 of 73
www.sieminc.com.cn

SIEMIC ACCREDITATION DETAILS: FCC Registration NO:986914





SIEMIC, Inc.

Accessing global markets

Title: RF Test Report for DSRC Road-Side Units
Model: DP268
To: FCC 15.247:2009

Serial#: 1002879
Issue Date: Sep 17 2010
Page: 64 of 73
www.sieminc.com.cn

SIEMIC ACCREDITATION DETAILS: FCC Listing, Registration NO:986914

FEDERAL COMMUNICATIONS COMMISSION

Laboratory Division
7435 Oakland Mills Road
Columbia, MD 21046

April 25, 2008

Registration Number: 986914

SIEMIC Nanjing (China) Laboratories
2-1 Longcang Avenue,
Yuhua Economic and Technology Development Park,
Nanjing, 210039
China

Attention: Leslie Bai

Re: Measurement facility located at 2-1 Longcang Avenue, Nanjing, China
Anechoic chamber (3 meters) and 3&10 meter OATS
Date of Listing: April 25, 2008

Dear Sir or Madam:

Your request for registration of the subject measurement facility has been reviewed and found to be in compliance with the requirements of Section 2.948 of the FCC rules. The information has, therefore, been placed on file and the name of your organization added to the list of facilities whose measurement data will be accepted in conjunction with applications for Certification under Parts 15 or 18 of the Commission's Rules. Please note that the file must be updated for any changes made to the facility and the registration must be renewed at least every three years.

Measurement facilities that have indicated that they are available to the public to perform measurement services on a fee basis may be found on the FCC website www.fcc.gov under E-Filing, OET Equipment Authorization Electronic Filing, Test Firms.

Sincerely,

Katie Hawkins
Electronics Engineer



SIEMIC, Inc.

Accessing global markets

Title: RF Test Report for DSRC Road-Side Units
Model: DP268
To: FCC 15.247:2009

Serial#: 1002879
Issue Date: Sep 17 2010
Page: 65 of 73
www.sieminc.com.cn

SIEMIC ACCREDITATION DETAILS: Industry of Canada Registration No. 4842



February 19, 2009

OUR FILE: 46405-4842
Submission No: 131645

SIEMIC NANJING (CHINA) LABORATORIES

2-1 Longcang Avenue
Yuhua Economic & Technology Dev. Park
Nanjing
China

Attention: Leslie Bai

Dear Sir/Madame:

The Bureau has received your application for the registration of a 3m/10m alternative test site. Be advised that the information received was satisfactory to Industry Canada. The following number(s) is now associated to the site(s) for which registration / renewal was sought (4842B-1). Please reference the appropriate site number in the body of test reports containing measurements performed on the site. In addition, please keep for your records the following information;

- Your primary code is: 4842

- The company number associated to the site(s) located at the above address is: 4842B

Furthermore, to obtain or renew a unique site number, the applicant shall demonstrate that the site has been accredited to ANSI C63.4-2003 or later. A scope of accreditation indicating the accreditation by a recognized accreditation body to ANSI C63.4-2003 shall be accepted. Please indicate in a letter the previous assigned site number if applicable and the type of site (example: 3 meter OATS or 3 meter chamber). If the test facility is not accredited to ANSI C63.4-2003 or later, the test facility shall submit test data demonstrating full compliance with the ANSI standard. The Bureau will evaluate the filing to determine if recognition shall be granted.

The frequency for re-validation of the test site and the information that is required to be filed or retained by the testing party shall comply with the requirements established by the accrediting organization. However, in all cases, test site re-validation shall occur on an interval not to exceed two years. There is no fee or form associated with an OATS filing. OATS submissions are encouraged to be submitted electronically to the Bureau using the following URL;

http://strategis.ic.gc.ca/epic/internet/inuceb-bhst.nsf/en/h_tt00052e.html.

If you have any questions, you may contact the Bureau by e-mail at certification_bureau@ic.gc.ca Please reference our file and submission number above for all correspondence.

Yours sincerely,

Joshua Laviolette
Foe: Wireless Laboratory Manager
Certification and Engineering Bureau
3701 Carling Ave., Building 94
P.O. Box 11490, Station "H"
Ottawa, Ontario K2H 8S2
Email: joshua.laviolette@ic.gc.ca
Tel. No. (613) 990-2681
Fax. No. (613) 990-4752



SIEMIC, INC.

Accessing global markets

Title: RF Test Report for DSRC Road-Side Units
Model: DP268
To: FCC 15.247:2009

Serial#: 1002879
Issue Date: Sep 17 2010
Page: 66 of 73
www.sieminc.com.cn

SIEMIC ACCREDITATION DETAILS: Japan RFT Accreditation No. MRF050927

RFT

Certificate

This is to certify that the
Quality Management System
of

SIEMIC , Inc.

**2206 Ringwood Avenue
San Jose, California 95131 U.S.A**

has been authorized to carry out Japan Specified Radio Equipment test by order and under supervision of RF Technologies Co., Ltd. according to Notification No.88 of Radio Law.

An assessment of the laboratory was conducted according to the "Procedure and Conditions for Appointments of 2.4GHz Band Low power data communications system that Bluetooth and Wireless LAN test with reference to ISO/IEC 17025 by an RF Technologies Co., Ltd. auditor.

Audit Report No. MRF050927

Kazuyuki Sarashina
Auditor
RF Technologies Co., Ltd.

Toshihiro Ikegami
President
RF Technologies Co., Ltd.

Audit Date
September 27th, 2005

Issued Date
October 5th, 2005

This Certificate is valid until **September 26th 2006 or next schedule audit.**

No:006 Registered Certification Body
RF Technologies Co., Ltd.
472, Nippa-cho, Kohoku-ku, Yokohama, 223-0057, Japan



SIEMIC ACCREDITATION DETAILS: Korea CAB from NIST: US0160



UNITED STATES DEPARTMENT OF COMMERCE
National Institute of Standards and Technology
Gaithersburg, Maryland 20899

October 1, 2008

Mr. Leslie Bai
SIEMIC, Inc.
2206 Ringwood Avenue
San Jose, CA 95131

Dear Mr. Bai:

NIST is pleased to inform you that your laboratory has been recognized by the Radio Research Agency (RRA) Korea Communications Commission (KCC) under the Asia Pacific Economic Cooperation for Telecommunications Equipment Mutual Recognition Arrangement (APEC Tel MRA). Your laboratory is now designated to act as a Conformity Assessment Body (CAB) under Appendix B, **Phase I** Procedures, of the APEC Tel MRA. The pertinent information about your laboratory's designation is as follows:

- CAB Name: SIEMIC, Inc.
- Physical Location: 2206 Ringwood Avenue, San Jose, CA 95131
- Identification No.: US0160
- Recognized Scope: **EMI:** KCC Notice 2008-39, RRL Notice 2008-3: CA Procedures for EMI KN22: Test Method for EMI
EMS: KCC Notice 2008-38, RRL Notice 2008-4: CA Procedures for EMS KN24, KN-61000-4-2, -4-3, -4-4, -4-5, -4-6, -4-8, -4-11: Test Method for EMS
Wireless: RRL Notice 2008-26, RRL Notice 2008-2, RRL Notice 2008-10, RRL Notice 2007-49, RRL Notice 2007-20, RRL Notice 2007-21, RRL Notice 2007-80, RRL Notice 2004-68
Wired: President Notice 20664, RRL Notice 2007-30, RRL Notice 2008-7 with attachments 1, 3, 5, 6
President Notice 20664, RRL Notice 2008-7 with attachment 4

You may submit test data to RRA/KCC to verify that the equipment to be imported into Korea satisfies the applicable requirements. The designation of your organization will remain in force as long as its accreditation for the designated scope remains valid and comply with the designation requirements.

Recognized CABs are listed on the NIST website at <http://ts.nist.gov/mra>. If you have any questions please contact Ramona Saar at (301) 975-5521 or ramona.saar@nist.gov.

Sincerely,

David F. Alderman
Group Leader, Standards Coordination and Conformity Group
Standards Services Division

Enclosure

cc: Ramona Saar





SIEMIC, Inc.

Accessing global markets

Title: RF Test Report for DSRC Road-Side Units
Model: DP268
To: FCC 15.247:2009

Serial#: 1002879
Issue Date: Sep 17 2010
Page: 68 of 73
www.sieminc.com.cn

SIEMIC ACCREDITATION DETAILS: Taiwan BSMI CAB Accreditation No. SL2-IN-E-1130R



UNITED STATES DEPARTMENT OF COMMERCE
National Institute of Standards and Technology
Gaithersburg, Maryland 20899-

May 3, 2006

Mr. Leslie Bai
SIEMIC Laboratories
2206 Ringwood Avenue
San Jose, CA 95131

Dear Mr. Bai:

I am pleased to inform you that your laboratory has been recognized by the Chinese Taipei's Bureau of Standards, Metrology, and Inspection (BSMI) under the Asia Pacific Economic Cooperation (APEC) Mutual Recognition Arrangement (MRA). Your laboratory is now designated to act as a Conformity Assessment Body (CAB) under Appendix B, **Phase I** Procedures, of the APEC Tel MRA. You may submit test data to BSMI to verify that the equipment to be imported into Chinese Taipei satisfies the applicable requirements. The designation of your organization will remain in force as long as its accreditation for the designated scope remains valid and comply with the designation requirements. The pertinent designation information is as follows:

- BSMI number: **SL2-IN-E-1130R** (Must be applied to the test reports)
- U.S Identification No: **US0160**
- Scope of Designation: **CNS 13438**
- Authorized signatory: **Mr. Leslie Bai**

The names of all recognized CABs will be posted on the NIST website at <http://ts.nist.gov/mra>. If you have any questions, please contact Mr. Dhillon at 301-975-5521. We appreciate your continued interest in our international conformity assessment activities.

Sincerely,

David F. Alderman
Group Leader, Standards Coordination and Conformity Group

cc: Jogindar Dhillon

NIST



SIEMIC, Inc.

Accessing global markets

Title: RF Test Report for DSRC Road-Side Units
Model: DP268
To: FCC 15.247:2009

Serial#: 1002879
Issue Date: Sep 17 2010
Page: 69 of 73
www.sieminc.com.cn

SIEMIC ACCREDITATION DETAILS: Taiwan NCC CAB ID: US0160



UNITED STATES DEPARTMENT OF COMMERCE
National Institute of Standards and Technology
Gaithersburg, Maryland 20899

March 16, 2009

Mr. Leslie Bai
SIEMIC, Inc.
2206 Ringwood Avenue
San Jose, CA 95131

Dear Mr. Bai:

NIST is pleased to inform you that your laboratory has been recognized by the National Communications Commission (NCC) for the requested scope expansion under the Asia Pacific Economic Cooperation for Telecommunications Equipment Mutual Recognition Arrangement (APEC Tel MRA). Your laboratory is designated to act as a Conformity Assessment Body (CAB) under Appendix B, **Phase I** Procedures, of the APEC Tel MRA. The pertinent information about your laboratory's designation is as follows:

CAB Name: SIEMIC, Inc.
Physical Location: 2206 Ringwood Avenue, San Jose, CA 95131
Identification No.: US0160
Current Scope: LP0002, PSTN01, ADSL01, ID0002, IS6100 and CNS 14336
Additional Scope: PLMN07

You may submit test data to NCC to verify that the equipment to be imported into China satisfies the applicable requirements. The designation of your organization will remain in force as long as its accreditation for the designated scope remains valid and comply with the designation requirements.

Recognized CABs are listed on the NIST website at <http://ts.nist.gov/mra>. If you have any questions please contact Ramona Saar at (301) 975-5521 or ramona.saar@nist.gov.

Sincerely,

David F. Alderman
Group Leader, Standards Coordination and Conformity Group
Standards Services Division

Enclosure

cc: Ramona Saar

NIST



SIEMIC, Inc.

Accessing global markets

Title: RF Test Report for DSRC Road-Side Units
Model: DP268
To: FCC 15.247:2009

Serial#: 1002879
Issue Date: Sep 17 2010
Page: 70 of 73
www.siemic.com.cn

SIEMIC ACCREDITATION DETAILS: Mexico NOM Recognition



CAMARA NACIONAL
DE LA INDUSTRIA
ELECTRONICA, DE
TELECOMUNICACIONES
E INFORMÁTICA

Laboratorio Valentín V. Rivero

México D.F. a 16 de octubre de 2006.

LESLIE BAI
DIRECTOR OF CERTIFICATION
SIEMIC LABORATORIES, INC.
ACCESSING GLOBAL MARKETS.
P R E S E N T E

En contestación a su escrito de fecha 5 de septiembre del año en curso, le comento que estamos muy interesados en su intención de firmar un Acuerdo de Reconocimiento Mutuo, para lo cual adjunto a este escrito encontrara el Acuerdo en idioma inglés y español prellenado de los cuales le pido sea revisado y en su caso corregido, para que si está de acuerdo poder firmarlo para mandarlo con las autoridades Mexicanas para su visto bueno y así poder ejercer dicho acuerdo.

Aprovecho este escrito para mencionarle que nuestro intermediario gestor será la empresa Isatel de México, S. A. de C. V., empresa que ha colaborado durante mucho tiempo con nosotros en lo relacionado a la evaluación de la conformidad y que cuenta con amplia experiencia en la gestión de la certificación de cumplimiento con Normas Oficiales Mexicanas de producto en México.

Me despido de usted enviándole un cordial saludo y esperando sus comentarios al Acuerdo que nos ocupa.

Atentamente:

Ing. Faustino Gomez Gonzalez
Gerente Técnico del Laboratorio de
CANIETI.

Calle 71
Hidrorená Condasa
06100 México, D.F.
Tel. 5264-0008 con 12 líneas
Fax 5264-0398
www.canieti.org



SIEMIC, Inc.

Accessing global markets

Title: RF Test Report for DSRC Road-Side Units
Model: DP268
To: FCC 15.247:2009

Serial#: 1002879
Issue Date: Sep 17 2010
Page: 71 of 73
www.siemic.com.cn

SIEMIC ACCREDITATION DETAILS: Hong Kong OFTA Recognition No. D23/16V



Your Ref 來函檔號 : D23/16 V
Our Ref 本局檔號 :

Telephone 電話 : (852) 2961 6320
Fax No 圖文傳真 : (852) 2838 5004
E-mail 電郵地址 : 20 July 2005

Mr. Leslie Bai
Director of Certification,
SIEMIC Laboratories
2206 Ringwood Avenue
San Jose, California 95131
USA

Dear Mr. Bai,

Application of Recognised Testing Agency (RTA)

Referring your submission of 28 June 2005 in relation to the application of RTA, I am pleased to inform you that OFTA has appointed SIEMIC Laboratories (SIEMIC) as a Recognised Testing Agency (RTA) :

Please note that, under the Hong Kong Telecommunications Equipment Evaluation and Certification (HKTEC) Scheme, SIEMIC is authorized to conduct evaluation tests on telecommunications equipment against the following HKTA specifications :

Scope of recognition (HKTA Specifications) :

1001, 1002, 1004, 1006, 1007, 1008
1010, 1015, 1016
1022, 1026, 1027, 1029
1030, 1031, 1032, 1033, 1034, 1035, 1039
1041, 1042, 1043, 1045, 1047, 1048
2001

You are requested to refer to and comply with the code of practice and guidelines for RTA as given in the Information Note OFTA I 411 "Recognised Testing Agency (RTA) for Conducting Evaluation Test of Telecommunications Equipment", which can be downloaded from OFTA's homepage at <http://www.ofta.gov.hk/tec/information-notes.html>.

If you have any queries, please do not hesitate to contact me.

Yours sincerely,

(K K Sin)
for Director-General
of Telecommunications

Office of the Telecommunications Authority
29/F Wu Chung House 213 Queen's Road East Wan Chai Hong Kong
電訊管理局
香港灣仔皇后大道東 213 號胡忠大廈 29 字樓

<http://www.ofta.gov.hk>



SIEMIC, Inc.

Accessing global markets

Title: RF Test Report for DSRC Road-Side Units
Model: DP268
To: FCC 15.247:2009

Serial#: 1002879
Issue Date: Sep 17 2010
Page: 72 of 73
www.sieminc.com.cn

SIEMIC ACCREDITATION DETAILS: OFTA CAB from NIST: US0160



UNITED STATES DEPARTMENT OF COMMERCE
National Institute of Standards and Technology
Gaithersburg, Maryland 20899

December 8, 2008

Mr. Leslie Bai
SIEMIC, Inc.
2206 Ringwood Avenue
San Jose, CA 95131

Dear Mr. Bai:

NIST is pleased to inform you that your laboratory has been recognized by the Office of the Telecommunications Authority (OFTA) under the Asia Pacific Economic Cooperation for Telecommunications Equipment Mutual Recognition Arrangement (APEC Tel MRA). Your laboratory is now designated to act as a Conformity Assessment Body (CAB) under Appendix B, **Phase I** Procedures, of the APEC Tel MRA. The pertinent information about your laboratory's designation is as follows:

CAB Name: SIEMIC, Inc.
Physical Location: 2206 Ringwood Avenue, San Jose, California 95131 USA
Identification No.: US0160
Recognized Scope: **Radio:** HKTA 1002, 1007, 1008, 1010, 1015, 1016, 1020, 1022, 1026, 1027, 1029, 1030, 1031, 1032, 1033, 1034, 1035, 1036, 1037, 1039, 1041, 1042, 1043, 1044, 1046, 1047, 1048, 1049, 1051
Telecom: HKTA 2011, 2012, 2013, 2014, 2017, 2018, 2022, 2024, 2026, 2027, 2028, 2029, 2030, 2031, 2032, 2033

You may submit test data to OFTA to verify that the equipment to be imported into Hong Kong satisfies the applicable requirements. The designation of your organization will remain in force as long as its accreditation for the designated scope remains valid and comply with the designation requirements.

Recognized CABs are listed on the NIST website at <http://ts.nist.gov/mra>. If you have any questions please contact Ramona Saar at (301) 975-5521 or ramona.saar@nist.gov.

Sincerely,

David F. Alderman
Group Leader, Standards Coordination and Conformity Group
Standards Services Division

Enclosure

cc: Ramona Saar

NIST



SIEMIC, Inc.

Accessing global markets

Title: RF Test Report for DSRC Road-Side Units
Model: DP268
To: FCC 15.247:2009

Serial#: 1002879
Issue Date: Sep 17 2010
Page: 73 of 73
www.sieminc.com.cn

SIEMIC ACCREDITATION DETAILS: Australia NATA Recognition



Leslie Bai
SIEMIC, Inc.
2206 Ringwood Avenue
San Jose, CA 95131

November 4, 2008

Under Australian government legislation, the Australian Communications and Media Authority (ACMA) has determined the National Association of Testing Authorities, Australia (NATA) as an accreditation body as per Section 409(1) of the Telecommunications Act 1997 (Cth). Pursuant to Section 409(2) of the Telecommunications Act 1997 (Cth), I am pleased to advise that your laboratory has been determined as a Recognised Testing Authority (RTA).

This determination has been made on the basis of your accreditation by A2LA accreditation no. 2742.01 and the Mutual Recognition Agreement between NATA and A2LA. It is effective from 11 July 2008. RTA status applies only to the following standards and is contingent upon their continued inclusion in your laboratory's scope of accreditation.

**AS/ACIF S002, AS/ACIF S003, AS/ACIF S004,
AS/ACIF S006, AS/ACIF S016, AS/ACIF S031,
AS/ACIF S038, AS/ACIF S041 and
AS/ACIF S043.2**

As an RTA, your laboratory has the following obligations:

1. the laboratory shall continue to meet all of the accreditation criteria of A2LA;
2. the authorised representative of the laboratory shall notify NATA of changes to the staff or operations of the laboratory which would affect the performance of the tests for which the laboratory has been determined;
3. compliance of equipment shall be reported on test reports bearing the A2LA logo/endorsement.

Current information on the Australian Communications and Media Authority and regulatory requirements for telecommunications products within Australia can be obtained from the ACMA's web-site at "<http://www.acma.gov.au>". Further information about NATA may be gained by visiting "<http://www.nata.asn.au>".

Please note that AS/ACIF S040 and New Zealand standards do not form part of the RTA scheme.

Your RTA listing will appear on the NATA website shortly.

Kind Regards

Chris Norton,
Senior Scientific Officer
Measurement Science and Technology
National Association of Testing Authorities (NATA)
71-73 Flemington Road
North Melbourne Vic 3051
Australia
Ph: +61 3 9329 1633 Fx: +61 3 9326 5148
E-Mail: Christopher.Norton@nata.asn.au
Internet: www.nata.asn.au