



Test Report No. 9212326108

Applicant: Stratasys Ltd.

Equipment Under Test:

Objet500 Material Cabinet

FCC ID: YH6-MATCAB

***From The Standards Institution
Of Israel
Industry Division
Electronics & Telematics Laboratory
EMC Branch***



***AClass Accreditation Services
Certificate Number: AT-1359***

**Test Report No.:** 9212326108

Page 1 of 20 pages

Title: Objet500 Material Cabinet

FCC ID: YH6-MATCAB

Model: RFID reader BRD-07000, antenna board BRD-03012

Applicant:	Stratasys Ltd.
Address:	2 Holzman St., Science Park, P.O.B 2496, Rehovot 76124, Israel
Sample for test selected by:	The customer
The date of test:	24 April, 25 June 2012

Description of Equipment Under Test (EUT):	Objet500 Material Cabinet
Model:	RFID reader BRD-07000, antenna board BRD-03012
Hardware version of radio unit	A
Software version of radio unit	1.1
Serial number:	NA
Manufactured by:	Stratasys Ltd.

Reference Documents:

- ❖ CFR 47 FCC: Rules and Regulations; Part 15. "Radio frequency devices";
Subpart B: "Unintentional radiators" (2009).
Section 15.109. Radiated emission limits.
Subpart C: "Intentional radiators" (2009),
Section 15.207. Conducted limits
Section 15.209. "Radiated emission limits, general requirements".

According to applicant declaration the name of the company and the EUT model noted on test results plots was changed as follows:

- 1) Company's name was changed from "Objet Ltd" to "Stratasys Ltd".
- 2) EUT name was changed from "Triplex Material Cabinet" to "Objet500 Material Cabinet"

This Test Report contains 20 pages and may be used only in full.	This Test Report applies only to the specimen tested and may not be applied to other specimens of the same product.
---	--



Test Report No.: 9212326108

Page 2 of 20 pages

Title: Objet500 Material Cabinet

FCC ID: YH6-MATCAB

Model: RFID reader BRD-07000, antenna board BRD-03012

1. Test summary

Parameter	FCC Part 15 Reference paragraph	Verdict
Radiated emission test.	Subpart C Section 15.209.	Comply
Radiated emission test.	Subpart B Section 15.109 class A	Comply
Conducted emissions test	Subpart C Section 15.207	Comply

Telematics Laboratory

January 2013

Name: Eng. Yuri Rozenberg
Position: Head of EMC Branch

Name: Michael Feldman
Position: Test Technician

Measurement uncertainty.

Were relevant, the following measurement uncertainty level have been estimated for tests performed on the EUT as specified in CISPR 16-4-2:

This uncertainty represents an expended uncertainty expressed at approximately the 95% confidence level using a coverage factor of k=2.

Test description	Expanded uncertainty
Conducted emissions from 150 kHz to 30 MHz	2 Uc (P) = ± 2.8 dB
Radiated emissions on the open field test site at 10 m measuring distance 30 MHz – 1.0 GHz	2 Uc (E) = ± 4.18 dB
at 3 m measuring distance 1.0 GHz – 18 GHz	2 Uc (E) = ± 4.47 dB



Test Report No.: 9212326108

Page 3 of 20 pages

Title: Objet500 Material Cabinet

FCC ID: YH6-MATCAB

Model: RFID reader BRD-07000, antenna board BRD-03012

Table of Contents

1. Test summary	2
2. EUT Description and operation	4
2.1. General description:	4
2.2. Potential emission sources:	8
2.3. EUT setup and operation:	8
3. Measurements, examinations and derived results	8
3.1. Location of the Test Site:	8
3.2. Test condition:	8
3.3. Initial visual check and functional test:	8
3.4. Radiated emission test.	9
3.5. Test of field strength emission from intentional radiator.	10
3.6. AC main conducted emissions test	13
3.7. Test of radiated emissions from unintentional radiator	16
4. Appendix 1. Test equipment used.	17
5. Appendix 2: Antenna Factor and Cable Loss	18

2. EUT Description and operation

2.1. General description:

* Note: the customer supplied all information in clause below.

The EUT is RFID transceiver on MSC board installed inside material resin cabinet of 3D printer. The cabinet contains two boards and eight antennas. Product's main functions are read and write data from material container protected by RFID identification tags attached to the resin material container. Its intended use is to identify the type of resin. The RFID unit voltage is 5V (produced from the main 24V). Through RS-232 interface the RFID MCU (PIC16F876A) gets commands: Number of channel, read or write etc. The RFID signal is generated by the RFID chip (HTRC11001). This RF signal from RFID chip is directed to a MUX chip that switches the RF energy to only one of the four channel antennas at certain time. RS-232 interface connected internally inside a 3D printer. The test was done by simulating all 8 channel antennas from two boards.

Transmit frequency:	125 kHz
Type of modulation:	AM
Antenna type:	Loop coil mfr. Objet mod. BRD-03012

The RFID and MSC board block diagrams are shown in Figures 1 and 2. The EUT's views are shown in photos below.

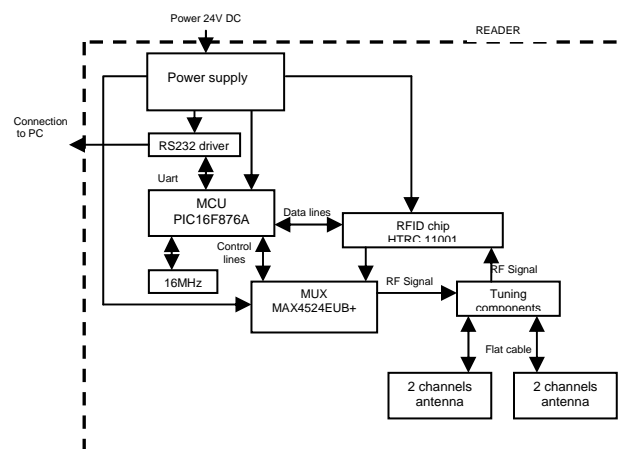

Figure 1. The RFID unit block-diagram.

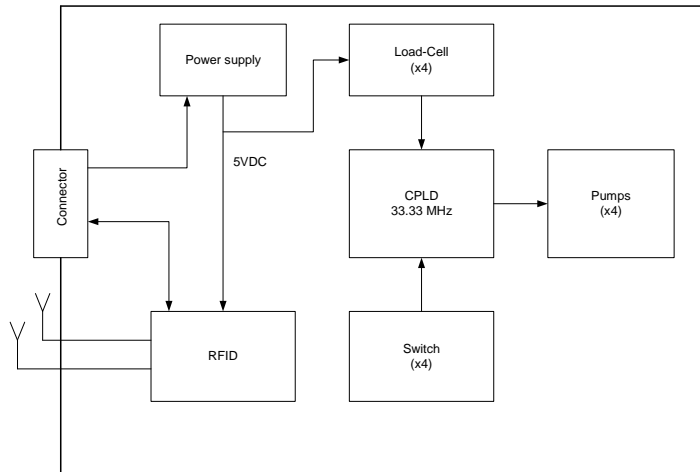

Figure 2. MSC board block diagram.

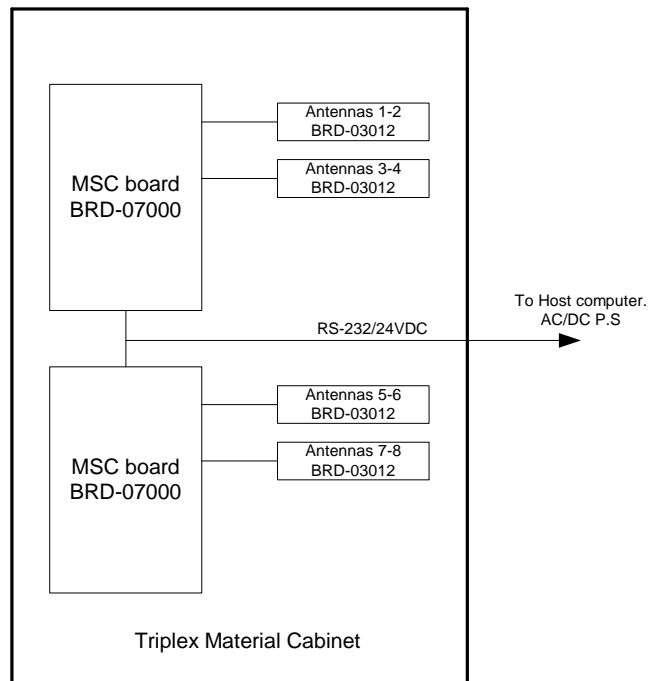

Figure 3. RE test setup block diagram.

Test Report No.: 9212326108

Page 6 of 20 pages

Title: Objet500 Material Cabinet

FCC ID: YH6-MATCAB

Model: RFID reader BRD-07000, antenna board BRD-03012



Photo 1. RE test setup.



Photo 2. RE test setup on OATS.



Test Report No.: 9212326108

Page 7 of 20 pages

Title: Objet500 Material Cabinet

FCC ID: YH6-MATCAB

Model: RFID reader BRD-07000, antenna board BRD-03012



Photo 3. RE test setup on OATS.

**Test Report No.:** 9212326108

Page 8 of 20 pages

Title: Objet500 Material Cabinet

FCC ID: YH6-MATCAB

Model: RFID reader BRD-07000, antenna board BRD-03012

2.2. Potential emission sources:

The potential emission sources are detailed in Table 1.

Table 1. Potential emission sources

Frequency	Location
125 kHz	RFID (derived from 16 MHz)
16 MHz crystal	RFID
33.3 MHz crystal	MSC board (CPLD)

2.3. EUT setup and operation:

Measurements were performed in continue transmittion mode by simulating all channel antennas and using Max Hold mode.

3. Measurements, examinations and derived results

3.1. Location of the Test Site:

Preliminary radiated test was conducted at the EMC laboratory of the Standards Institution of Israel in Tel-Aviv.

The final radiated emission test was conducted in an Open Area Test Site located at Kibbutz Native Halamed Hai in Emek HaEla, Israel.

3.2. Test condition:

Temperature: 24°C. Humidity: 63 %. Atmospheric pressure: 1012 mbar.

3.3. Initial visual check and functional test:

Initial visual check and brief built- in- test of the EUT was performed before testing.

- No external damages were found.
- The test on the EUT passed successfully.

**Test Report No.:** 9212326108

Page 9 of 20 pages

Title: Objet500 Material Cabinet

FCC ID: YH6-MATCAB

Model: RFID reader BRD-07000, antenna board BRD-03012

3.4. Radiated emission test.

3.4.1. General:

Per FCC Part 15 subpart B, C Sections 15.109, 15.209

3.4.2. Preliminary radiated emission tests:

Preliminary investigation measurements were performed up to tenth harmonic of fundamental in a semi-anechoic chamber at distance 3 meter. The EUT was setup in its typical configuration and operated in its various modes. For each mode of operation the frequency spectrum was monitored. EUT configuration, cable configuration and mode of operation, which produced the maximum level of emission, were documented. A list of frequencies to be tested was prepared.

3.4.3. Final measurements procedure:

The final radiated emission measurements were performed at the Open Area Test Site at 3 and 10m test distances. The EUT was operated as described above. The EUT was installed on a turn - table. Measurements were performed with active loop antenna at frequencies below 30 MHz and with Biconilog 30 MHz-2 GHz antenna above 30 MHz. The measurements were performed at each frequency that was founded previously at which the signal level was 10 dB below the limit or less. The levels were maximized by rotating turntable through 360° and changing antenna-to-EUT polarization from vertical to horizontal. The worse case result was noted in tables.

3.4.4. Radiated emission test results:

All received emissions from the RFID transmitter were found below FCC Part 15 Subpart C sections 15.209 and below FCC part 15.109 class A limit for digital part. Final result measurements are presented in table #2 in section 3.5.5 and table #3 section 3.7.

**Test Report No.: 9212326108****Page 10 of 20 pages****Title:** Objet500 Material Cabinet**FCC ID:** YH6-MATCAB**Model:** RFID reader BRD-07000, antenna board BRD-03012

3.5. Test of field strength emission from intentional radiator.

3.5.1. General:

Per FCC Part 15 Subpart C section 15.209 (a).

3.5.2. Requirements:

The RFID operation frequency is 125 kHz.

The average field strength emission from intentional radiators operated on this frequency shall comply with the limit of section 15.209 (a).

Emission frequency MHz	Specified Field Strength limit of Fundamental $\mu\text{V/m}@300\text{m}$	Calculated Field Strength limit $\text{dB}\mu\text{V/m}@3\text{m}$
0.125	2400/F	105.6

Note: The field strength limit was calculated with 40 dB/decade linear distance extrapolation factor.

The field strength of any unwanted emissions shall not exceed the general radiated emission limits in § 15.209.

3.5.3. Test procedure:

The test was conducted according to clause 15.209.

3.5.4. Test summary:

The tested unit meets the standard requirement.



Test Report No.: 9212326108

Page 11 of 20 pages

Title: Objet500 Material Cabinet

FCC ID: YH6-MATCAB

Model: RFID reader BRD-07000, antenna board BRD-03012

3.5.5. Test results:

Table # 2. Fundamental frequency test result

Carrier frequency MHz	Peak amplitude dBµV/m	Limit@ 3m dBµV/m
0.125	71.5	105.6

For recorded fundamental frequency result see plot #1. The received radiated emission result was found below the § 15.209 specified limit. Investigation scans of spurious emission present in plots #2 and #3

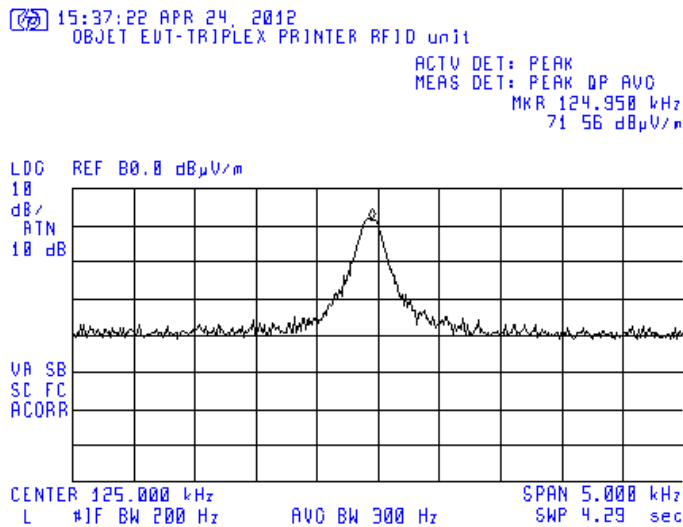

Plot # 1. Field strength of fundamental frequency 125 kHz.



Test Report No.: 9212326108

Page 12 of 20 pages

Title: Objet500 Material Cabinet

FCC ID: YH6-MATCAB

Model: RFID reader BRD-07000, antenna board BRD-03012

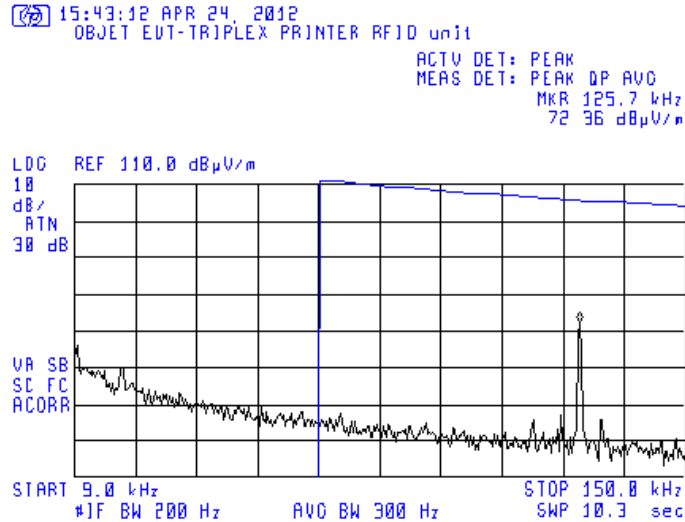

Plot # 2. Frequency scan 0.09 - 0.15 MHz. Test distance =3m.

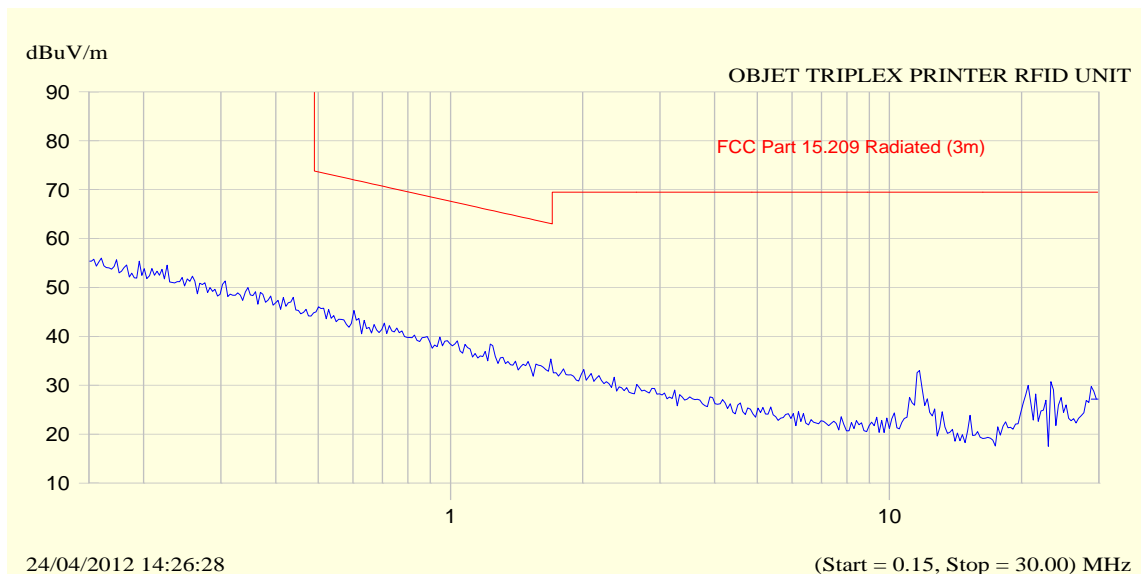

Plot # 3. Frequency scan 0.15 – 30 MHz. Test distance =3m.



Test Report No.: 9212326108

Page 13 of 20 pages

Title: Objet500 Material Cabinet

FCC ID: YH6-MATCAB

Model: RFID reader BRD-07000, antenna board BRD-03012

3.6. AC main conducted emissions test

Per FCC Part 15 subpart C Section 15.207

Test configuration:

The EUT was placed on a non-metallic table in a shielded room at a height of 80 cm from the floor and 40 cm from the vertical ground plane (wall) of the room.

3.6.1. **Test procedure:**

First, initial scans were performed. Final measurements were performed at the frequencies where emission exceeded the tolerance limit.

Test equipment (EMI receiver) setup was as follow:

Initial scan:

Detector type	Peak
Mode	Max hold
Bandwidth	9 kHz
Sweep time	>100 msec

Measurements:

Detector type	Quasi-peak (CISPR), Average
Bandwidth	9 kHz
Observation	>15 seconds

3.6.2. **Test results:**

All received emissions from EUT were found below FCC Part 15.207 limits (see plots ## 4, 5 below).

Test Report No.: 9212326108

Page 14 of 20 pages

Title: Objet500 Material Cabinet

FCC ID: YH6-MATCAB

Model: RFID reader BRD-07000, antenna board BRD-03012

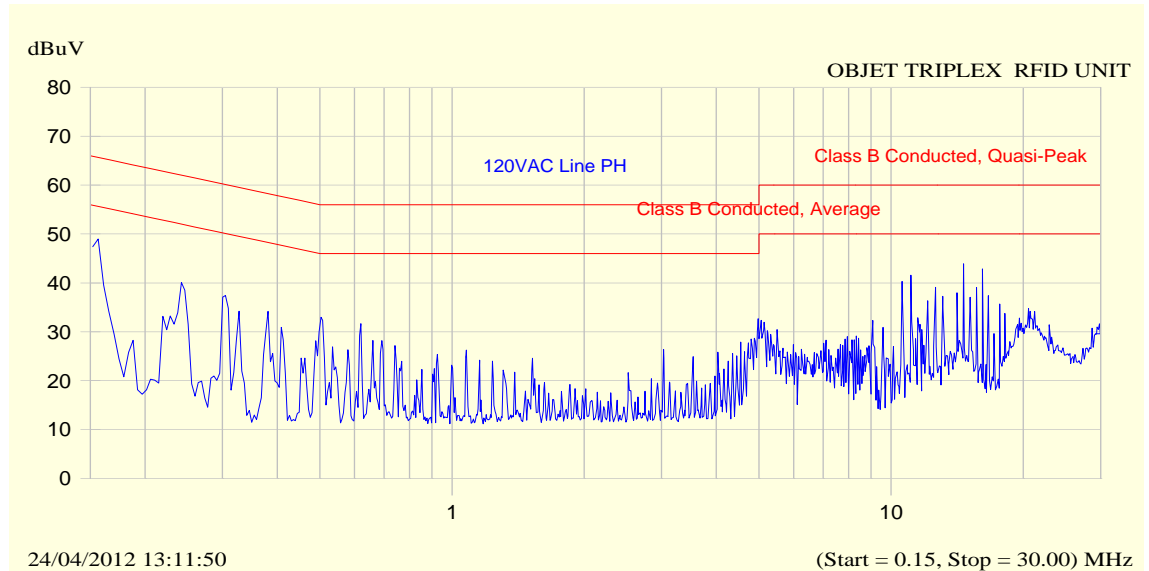

Frequency MHz	Peak dB μ V	QP dB μ V	QP Limit dB μ V	Margin dB	Avg dB μ V	Avg Limit dB μ V	Margin dB
0.155	51.6	49.9	65.7	-15.8	44.1	55.7	-11.6
0.307	40.1	37.8	60.1	-22.3	33.7	50.1	-16.4
10.602	41.2	40.1	60.0	-19.9	39.3	50.0	-10.7
11.107	42.4	41.7	60.0	-18.3	40.9	50.0	-9.1
14.640	43.8	43.2	60.0	-16.8	42.8	50.0	-7.2
16.155	42.9	41.7	60.0	-18.3	41.3	50.0	-8.7

Plot # 4. Tested line Phase

Test Report No.: 9212326108

Page 15 of 20 pages

Title: Objet500 Material Cabinet

FCC ID: YH6-MATCAB

Model: RFID reader BRD-07000, antenna board BRD-03012

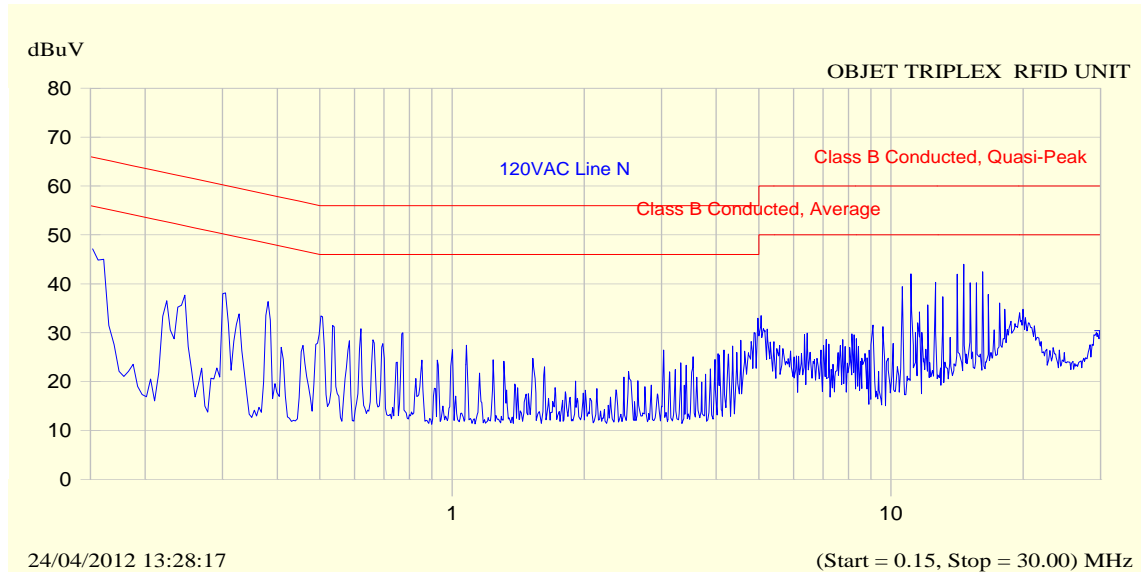

Frequency MHz	Peak dB μ V	QP dB μ V	QP Limit dB μ V	Margin dB	Avg dB μ V	Avg Limit dB μ V	Margin dB
0.155	52.2	50.4	65.7	-15.3	44.9	55.7	-10.8
0.307	40.1	37.7	60.1	-22.3	33.7	50.1	-16.4
10.602	40.1	39.5	60.0	-20.5	39.0	50.0	-11.0
11.107	42.7	41.7	60.0	-18.3	40.8	50.0	-9.2
14.641	44.3	43.3	60.0	-16.7	42.8	50.0	-7.2
16.155	43.0	42.1	60.0	-17.9	40.9	50.0	-9.1

Plot # 5. Tested line Neutral



Test Report No.: 9212326108

Page 16 of 20 pages

Title: Objet500 Material Cabinet

FCC ID: YH6-MATCAB

Model: RFID reader BRD-07000, antenna board BRD-03012

3.7. Test of radiated emissions from unintentional radiator

Per FCC Part 15 subpart B Section 15.109

3.7.1. Test procedure:

The EUT was on at normal performance.

First, initial scans were performed. Final measurements were performed according to clause 3.4.3.

Initial scan:

Detector type Peak
 Mode Max hold
 Bandwidth 120 kHz
 Sweep time >1 seconds/MHz

Measurements:

Detector type Quasi-peak (CISPR)
 Bandwidth 120 kHz
 Measurement time 20 seconds/MHz

3.7.2. Radiated emission test results:

All received emissions were found below FCC Part 15 class A limits and presented in table # 3 below.

**Table 3. Radiated emission test results
 Subpart B class A 10m distance.**

Frequency (MHz)	Antenna Polariz. V/H	Antenna Height (m)	Turn-table Angle (°)	Emission Level Note 1 dBµV/m	Limit @ 10 m dBµV/m	Margin (dB)	Results
45.5	V	1.0	269	30.1	39.0	-8.9	Complies
116.1	V	1.0	111	32.1	43.5	-11.4	Complies
139.4	V	1.0	288	33.7	43.5	-9.8	Complies
146.5	V	1.0	288	35.9	43.5	-7.6	Complies
153.9	V	1.0	160	37.7	43.5	-5.8	Complies
165.2	V	1.0	142	29.6	43.5	-13.9	Complies

Note 1: Emission level = E Reading (dBµV) + Cable loss (dB) + Antenna Factor (dB/m)
 For Cable Loss and Antenna Factor refer to Appendix 2

**Test Report No.:** 9212326108

Page 17 of 20 pages

Title: Objet500 Material Cabinet

FCC ID: YH6-MATCAB

Model: RFID reader BRD-07000, antenna board BRD-03012

4. Appendix 1. Test equipment used.

All measurements equipment is on SII calibration schedule with a recalibration interval not exceeding one year.

Instrument	MFR	Model	Serial No.	Due calibration date
EMI Receiver 9 kHz – 6.5 GHz	HP	8546A+85460 A	SII 4068	May 2013
Active Loop Antenna 10 kHz – 30 MHz	EMCO	6502	3283	Oct 2012
Antenna Biconilog 30 – 2000 MHz	Schaffner- Chase	CBL6112B	S/N 23181	Dec 2012
EMI Analyser 9 kHz - 26.5 GHz	HP	E7405A	SII 4944	March 2013
LISN 9 kHz – 30 MHz	FCC	LISN 250-32- 4-16	SII5023	Dec 2012
Transient limiter 0.009-200 MHz	HP	11947A	3107105	May 2013
Oscilloscope	HP	54610B	US37340682	April 2013
RF cable, 4m	Sucoflex	104PE	21328/4PE	Oct 2012
Temperature/Humidity cabinet	Heraeus	HC 4033	SII 4062	Jan 2013
Antenna Mast	R&S	HCM	100002	N/A
Metallic turntable	R&S	HCT12	100001	N/A
Positioning controller	R&S	HCC	100002	N/A

Test Report No.: 9212326108

Page 18 of 20 pages

Title: Objet500 Material Cabinet

FCC ID: YH6-MATCAB

Model: RFID reader BRD-07000, antenna board BRD-03012

5. Appendix 1: Antenna Factor and Cable Loss

Table 4. Cables #8 and #10 loss (10m cable + Mast).

Point	Frequency (MHz)	Cable Loss (dB)	Point	Frequency (MHz)	Cable Loss (dB)
1	30	0.53	21	1000	3.68
2	50	0.75	22	1100	3.82
3	100	1.08	23	1200	4.07
4	150	1.39	24	1300	4.24
5	200	1.61	25	1400	4.43
6	250	1.752	26	1500	4.6
7	300	2.00	27	1600	4.7
8	350	2.15	28	1700	4.85
9	400	2.26	29	1800	4.98
10	450	2.383	30	1900	5.19
11	500	2.52	31	2000	5.34
12	550	2.606	32	2100	5.51
13	600	2.75	33	2200	5.69
14	650	2.856	34	2300	5.89
15	700	3.06	35	2400	6.07
16	750	3.20	36	2500	6.22
17	800	3.27	37	2600	6.28
18	850	3.38	38	2700	6.41
19	900	3.46	39	2800	6.53
20	950	3.55	40	2900	6.84



Test Report No.: 9212326108

Page 19 of 20 pages

Title: Objet500 Material Cabinet

FCC ID: YH6-MATCAB

Model: RFID reader BRD-07000, antenna board BRD-03012

Table 5. Antenna Factor
For Biconilog Antenna, Model Number: CBL 6112D, S/N: 23181

No.	f / MHz)	AF / dB/m	f / MHz)	AF / dB/m	f / MHz)	AF / dB/m	f / MHz)	AF / dB/m
1	30	17.90	170	9.40	530	17.70	1040	22.20
2	32	16.70	175	9.00	540	18.25	1060	22.50
3	34	15.55	180	8.50	550	18.60	1080	22.50
4	36	14.35	185	8.45	560	14.45	1100	22.40
5	38	13.30	190	8.60	570	18.40	1120	22.60
6	40	12.20	195	8.85	580	18.50	1140	22.45
7	42	11.05	200	8.95	590	18.60	1160	22.50
8	44	9.95	205	8.80	600	18.60	1180	22.40
9	46	8.90	210	8.50	610	18.80	1200	22.80
10	48	8.05	215	8.20	620	18.99	1220	22.95
11	50	7.30	220	8.50	630	19.05	1240	23.10
12	52	6.80	225	9.00	640	19.23	1260	23.40
13	54	6.45	230	9.65	650	19.10	1280	23.35
14	56	6.00	235	10.30	660	19.13	1300	23.62
15	58	5.70	240	11.00	670	19.04	1320	23.64
16	60	5.45	245	11.60	680	19.00	1340	23.86
17	62	5.30	250	12.00	690	19.17	1360	23.95
18	64	5.20	255	12.45	700	19.28	1380	23.90
19	66	5.30	260	12.85	710	19.25	1400	24.45
20	68	5.30	265	12.50	720	19.45	1420	24.74
21	70	5.35	270	12.45	730	19.75	1440	24.93
22	72	5.50	275	12.40	740	19.95	1460	25.03
23	74	5.80	280	12.55	750	20.07	1480	25.45
24	76	6.00	285	12.65	760	19.85	1500	25.30
25	78	6.60	290	12.75	770	19.80	1520	25.25
26	80	6.70	295	12.95	780	19.85	1540	25.36
27	82	7.15	300	13.00	790	19.95	1560	25.58
28	84	7.60	310	13.35	800	20.05	1580	25.50
29	86	8.10	320	13.75	810	20.10	1600	25.65
30	88	8.50	330	13.85	820	20.35	1620	25.60
31	90	8.90	340	14.10	830	20.40	1640	25.70
32	92	9.20	350	14.50	840	20.35	1660	25.83
33	94	9.75	360	14.70	850	20.46	1680	25.97
34	96	9.95	370	14.90	860	20.39	1700	26.10
35	98	10.20	380	15.10	870	20.29	1720	26.25
36	100	10.50	390	15.45	880	20.24	1740	26.04
37	105	11.25	400	16.00	890	20.35	1760	26.14
38	110	11.70	410	16.40	900	20.55	1780	26.20
39	115	11.70	420	16.70	910	20.45	1800	26.40
40	120	11.80	430	16.35	920	20.60	1820	26.64
41	125	11.80	440	16.30	930	20.60	1840	26.86
42	130	11.70	450	16.30	940	20.66	1860	27.12
43	135	11.35	460	16.70	950	20.88	1880	27.00
44	140	10.95	470	17.05	960	21.11	1900	27.25
45	145	10.35	480	17.20	970	20.93	1920	27.36
46	150	10.05	490	17.30	980	21.03	1940	27.68
47	155	9.70	500	17.40	990	21.05	1960	27.10
48	160	9.70	510	17.50	1000	21.10	1980	27.06
49	165	9.45	520	17.60	1020	21.40	2000	27.25



Test Report No.: 9212326108

Page 20 of 20 pages

Title: Objet500 Material Cabinet

FCC ID: YH6-MATCAB

Model: RFID reader BRD-07000, antenna board BRD-03012

Antenna factor
Active Loop antenna mfr.EMCO mod. 6502 S/N 3424

Frequency (MHz)	Magnetic Antenna Factor (dBS/m)	Electric Antenna Factor (dB)
0.009	-31.46	20.07
0.010	-32.34	19.18
0.020	-36.15	15.38
0.050	-38.57	12.96
0.075	-38.78	12.75
0.100	-39.07	12.46
0.150	-39.07	12.45
0.250	-39.18	12.35
0.500	-39.29	12.24
0.750	-39.38	12.14
1.000	-39.57	11.95
2.000	-39.84	11.69
3.000	-40.09	11.44
4.000	-40.13	11.40
5.000	-40.24	11.28
10.000	-40.26	11.27
15.000	-40.70	10.83
20.000	-41.02	10.51
25.000	-41.94	9.59
30.000	-43.39	8.14

Cable Loss
Type: Sucoflex 104PE; Ser.No.21328/4PE; 4 m length

Point	Frequency (GHz)	Cable Loss (dB)
1	0.0-1.0	1.7
2	1.0- 3.5	3.2
3	3.5- 5.5	4.0
4	5.5 - 7.5	4.7
5	7.5 - 9.5	5.3
6	9.5 - 10.5	5.6
7	10.5 - 12.5	6.2
8	12.5 - 14.5	6.8
9	14.5 - 16.5	7.5
10	16.5 - 18.0	8.1