



# FCC Test Report

## FCC ID:YH5-8DTB37

**Product :** W8 Tablet

**Trade Name :** ***hipstreet***

**Model Number :** 8DTB37

**Serial Model :** N/A

**Report No. :** NTEK-2014NT0916405F3

**Prepared for**

Kobian Canada Inc.

560 Denison Street, Unit 5. Markham, Ontario, L3R 2M8. Canada

**Prepared by**

Shenzhen NTEK Testing Technology Co., Ltd.

1/F, Building E, Fenda Science Park, Sanwei Community, Xixiang Street,  
Bao'an District, Shenzhen P.R. China

Tel.: +86-0755-61156588 Fax.: +86-0755-61156599

Website: [www.ntek.org.cn](http://www.ntek.org.cn)

## TEST RESULT CERTIFICATION

**Applicant's name** ..... : Kobian Canada Inc.

Address ..... : 560 Denison Street, Unit 5.Markham, Ontario, L3R 2M8.Canada

**Manufacturer's Name** ..... : Kobian Canada Inc.

Address ..... : 560 Denison Street, Unit 5.Markham, Ontario, L3R 2M8.Canada

### Product description

Product name ..... : W8 Tablet

Model and/or type reference : 8DTB37

FCC Part15B:01 Oct.2013

**Standards** ..... : ANSI C63.4:2003

This device described above has been tested by NTEK, and the test results show that the equipment under test (EUT) is in compliance with Part 15 of FCC Rules. And it is applicable only to the tested sample identified in the report.

This report shall not be reproduced except in full, without the written approval of NTEK, this document may be altered or revised by NTEK, personal only, and shall be noted in the revision of the document.

**Date of Test** .....

Date (s) of performance of tests ..... : 16 Sep. 2014 ~25 Sep. 2014

Date of Issue..... : 25 Sep. 2014

Test Result..... : **Pass**

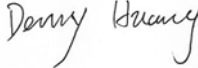
Testing Engineer :   
\_\_\_\_\_

Denny Huang

Technical Manager :   
\_\_\_\_\_

(Brown Lu)

Authorized Signatory :   
\_\_\_\_\_

(Bill Yao)

<b>Table of Contents</b>	<b>Page</b>
1 . TEST SUMMARY	4
1.1 TEST FACILITY	5
1.2 MEASUREMENT UNCERTAINTY	5
2 . GENERAL INFORMATION	6
2.1 GENERAL DESCRIPTION OF EUT	6
2.2 DESCRIPTION OF TEST SETUP	8
2.3 DESCRIPTION TEST PERIPHERAL AND EUT PERIPHERAL	9
2.4 MEASUREMENT INSTRUMENTS LIST	10
3 . EMC EMISSION TEST	11
3.1 CONDUCTED EMISSION MEASUREMENT	11
3.1.1 POWER LINE CONDUCTED EMISSION	11
3.1.2 TEST PROCEDURE	12
3.1.3 TEST SETUP	12
3.1.4 EUT OPERATING CONDITIONS	12
3.1.5 TEST RESULTS	13
3.2 RADIATED EMISSION MEASUREMENT	15
3.2.1 LIMITS OF RADIATED EMISSION MEASUREMENT	15
3.2.2 TEST PROCEDURE	15
3.2.3 TEST SETUP	16
3.2.4 EUT OPERATING CONDITIONS	17
3.2.5 TEST RESULTS	18
3.2.6 TEST RESULTS(1000~12400MHz)	21
4 . EUT TEST PHOTO	22

## 1. TEST SUMMARY

Test procedures according to the technical standards:

EMC Emission				
Standard	Test Item	Limit	Judgment	Remark
FCC Part15B:2013 ANSI C63.4: 2003	Conducted Emission	Class B	PASS	
	Radiated Emission	Class B	PASS	

**NOTE:**

- (1) 'N/A' denotes test is not applicable in this Test Report
- (2) For client's request and manual description, the test will not be executed.

1.1 TEST FACILITY

NTEK Testing Technology Co., Ltd

Add. : 1/F, Building E, Fenda Science Park, Sanwei Community, Xixiang Street, Bao'an District, Shenzhen P.R. China.

FCC Registration Number:238937; IC Registration Number:9270A-1

CNAS Registration Number:L5516

1.2 MEASUREMENT UNCERTAINTY

The reported uncertainty of measurement  $y \pm U$ , where expanded uncertainty  $U$  is based on a standard uncertainty multiplied by a coverage factor of  $k=2$ , providing a level of confidence of approximately **95** %.

A. Conducted Measurement :

Test Site	Method	Measurement Frequency Range	U , (dB)	NOTE
NTEKC01	ANSI	150 KHz ~ 30MHz	3.2	

B. Radiated Measurement :

Test Site	Method	Measurement Frequency Range	U , (dB)	NOTE
NTEKA01	ANSI	30MHz ~ 1000MHz	4.7	
		1GHz ~12.4GHz	5.0	

## 2. GENERAL INFORMATION

### 2.1 GENERAL DESCRIPTION OF EUT

Equipment	W8 Tablet	
Model Name	8DTB37	
Additional Model Number(s)	N/A	
Model Difference	N/A	
Product Description	The EUT is a W8 Tablet.	
	Connecting I/O port:	USB, DC in ,HDMI
	Operation Frequency:	BT:2402~2480 MHz WIFI: 802.11b/g/n(20MHz): 2412~2462MHz 802.11n(40MHz):2422~2452MHz
	Modulation Type:	BT(1Mbps): GFSK BT EDR(2Mbps): $\pi/4$ -DQPSK BT EDR(3Mbps): 8-DPSK WIFI: CCK/OFDM/DBPSK/DAPSK
	Based on the application, features, or specification exhibited in User's Manual, the EUT is considered as an ITE/Computing Device. More details of EUT technical specification, please refer to the User's Manual.	
Power Source	DC Voltage	
Adapter	Model:Inco Duplet Input: 100-240V,50/60 Hz,0.5A Output: 9.0V $\overline{\text{---}}$ , 2000mA	
Battery	DC 3.7V ,5000mAh	

### 2.1.1 DESCRIPTION OF TEST MODES

To investigate the maximum EMI emission characteristics generates from EUT, the test system was pre-scanning tested base on the consideration of following EUT operation mode or test configuration mode which possible have effect on EMI emission level. Each of these EUT operation mode(s) or test configuration mode(s) mentioned above was evaluated respectively.

Pretest Mode	Description
Mode 1	TF Card Playing+chagring
Mode 2	HDMI
Mode 3	Data Exchange
Mode 4	REC

For Conducted Test	
Final Test Mode	Description
Mode 1	TF Card Playing+chagring
Mode 2	HDMI
Mode 3	Data Exchange
Mode 4	REC

For Radiated Test	
Final Test Mode	Description
Mode 1	TF Card Playing+chagring
Mode 2	HDMI
Mode 3	Data Exchange
Mode 4	REC

Note: Final Test Mode: Through Pre-scan, find the mode 3 is the worse case. Only the worst case mode is recorded in the report.

### 2.2 DESCRIPTION OF TEST SETUP

RE

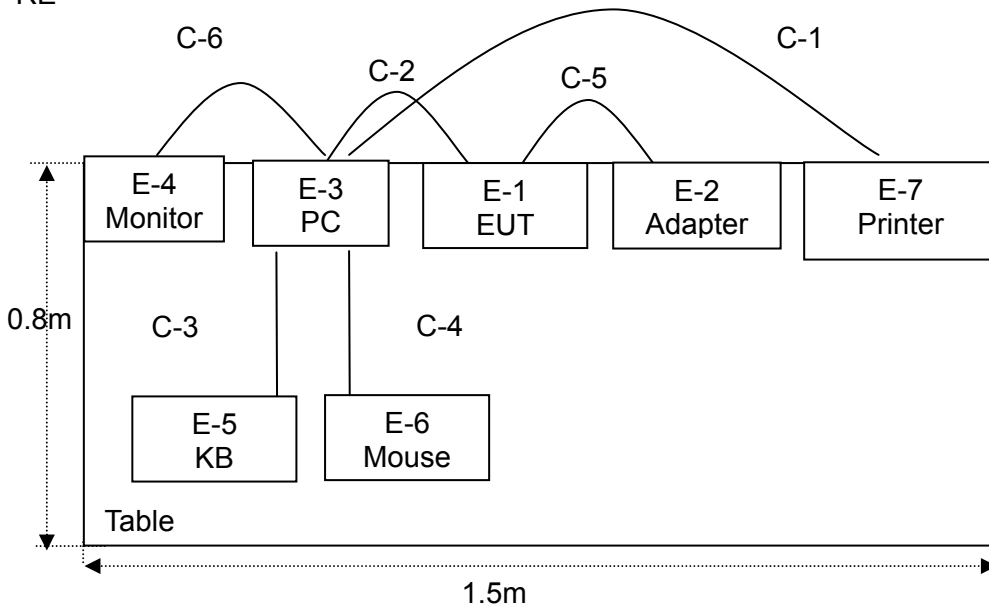

CE

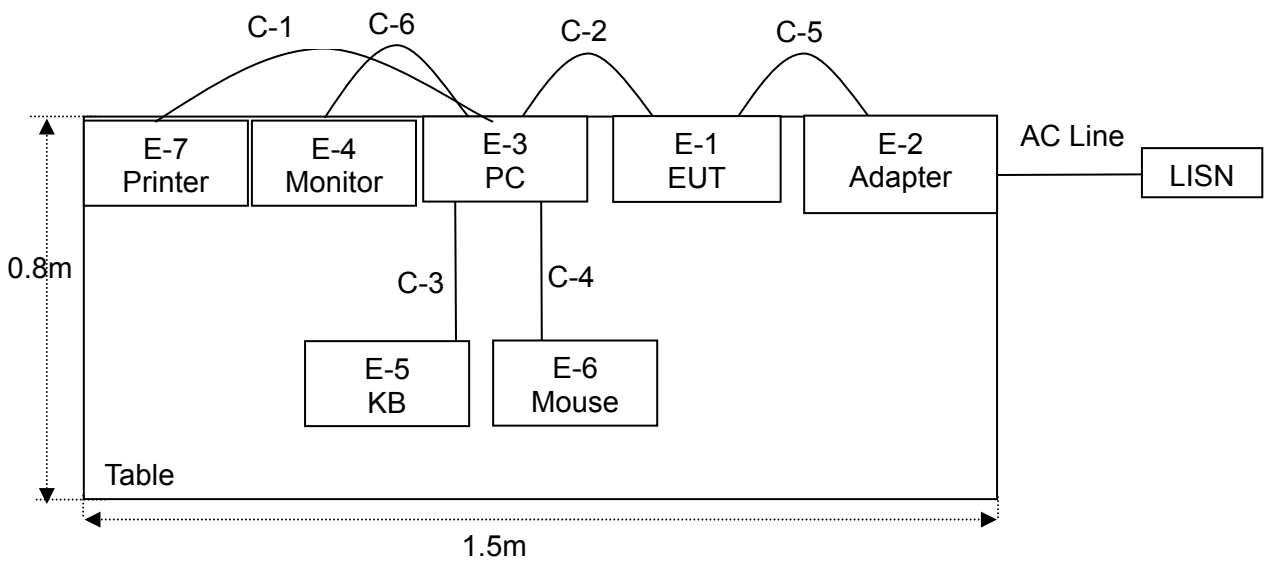



### 2.3 DESCRIPTION TEST PERIPHERAL AND EUT PERIPHERAL

The EUT has been tested as an independent unit together with other necessary accessories or support units. The following support units or accessories were used to form a representative test configuration during the tests.

Item	Equipment	Brand	Model/Type No.	Series No.	Note
E-1	W8 Tablet	<b>hipstreet</b>	8DTB37	N/A	EUT
E-2	ADAPTER	N/A	Inco Duplet	N/A	
E-3	Personal computer	DELL	FT4Y23X	34413561645	
E-4	Monitor	DELL	IN2020MB	cn-0y6mhx-74261-11f-67es	
E-5	Keyboard	DELL	SK-8185	OY526KUS	
E-6	Mouse	DELL	MS111-P	cn-011d3v-71581-11e-1th7	
E-7	Printer	Canon	L11121E	LBP2900	

Item	Shielded Type	Ferrite Core	Length	Note
C-1	NO	NO	1.2m	
C-2	NO	NO	1.0m	
C-3	NO	NO	1.0m	
C-4	NO	NO	1.0m	
C-5	NO	NO	1.0m	
C-6	NO	NO	1.0m	

**Note:**

- (1) The support equipment was authorized by Declaration of Confirmation.
- (2) For detachable type I/O cable should be specified the length in cm in 『Length』 column.
- (3) “YES” means “shielded” “with core”; “NO” means “unshielded” “without core”.

## 2.4 MEASUREMENT INSTRUMENTS LIST

### 2.4.1 CONDUCTED TEST SITE

Item	Kind of Equipment	Manufacturer	Type No.	Serial No.	Last calibration	Calibrated until	Calibration period
1	LISN	R&S	ENV216	101313	Jul. 06, 2014	Jul. 05, 2015	1 year
2	LISN	SCHWARZBECK	NNLK 8129	8129245	Dec. 25, 2013	Dec. 24, 2014	1 year
3	Pulse Limiter	SCHWARZBECK	VTSD 9561F	9716	Dec. 25, 2013	Dec. 24, 2014	1 year
4	50Ω Switch	ANRITSU CORP	MP59B	6200983704	Jul. 06, 2014	Jul. 05, 2015	1 year
5	Test Cable	N/A	C01	N/A	Jul. 06, 2014	Jul. 05, 2015	1 year
6	Test Cable	N/A	C02	N/A	Jul. 06, 2014	Jul. 05, 2015	1 year
7	Test Cable	N/A	C03	N/A	Jul. 06, 2014	Jul. 05, 2015	1 year
8	EMI Test Receiver	R&S	ESCI	101160	Jul. 06, 2014	Jul. 05, 2015	1 year
9	Passive Voltage Probe	ESH2-Z3	R&S	100196	Jul. 06, 2014	Jul. 05, 2015	1 year
10	Absorbing Clamp	R&S	MDS-21	100423	Jul. 08, 2014	Jul. 07, 2015	1 year

### 2.4.2 RADIATED TEST SITE

Item	Kind of Equipment	Manufacturer	Type No.	Serial No.	Last calibration	Calibrated until	Calibration period
1	Bilog Antenna	TESEQ	CBL6111D	31216	Jul. 06, 2014	Jul. 05, 2015	1 year
2	Test Cable	N/A	R-01	N/A	Dec. 25, 2013	Dec. 24, 2014	1 year
3	Test Cable	N/A	R-02	N/A	Dec. 25, 2013	Dec. 24, 2014	1 year
4	EMI Test Receiver	R&S	ESCI-7	101318	Jul. 06, 2014	Jul. 05, 2015	1 year
5	Antenna Mast	EM	SC100_1	N/A	N/A	N/A	N/A
6	Turn Table	EM	SC100	060531	N/A	N/A	N/A
7	50Ω Switch	Anritsu Corp	MP59B	6200983705	Jul. 06, 2014	Jul. 05, 2015	1 year
8	Spectrum Analyzer	Aglient	E4407B	MY45108040	Jul. 06, 2014	Jul. 05, 2015	1 year
9	Horn Antenna	EM	EM-AH-10180	2011071402	Jul. 06, 2014	Jul. 05, 2015	1 year
10	Amplifier	EM	EM-30180	060538	Jul. 06, 2014	Jul. 05, 2015	1 year
11	Loop Antenna	ARA	PLA-1030/B	1029	Jul. 06, 2014	Jul. 05, 2015	1 year

### 3. EMC EMISSION TEST

#### 3.1 CONDUCTED EMISSION MEASUREMENT

##### 3.1.1 POWER LINE CONDUCTED EMISSION (Frequency Range 150KHz-30MHz)

FREQUENCY (MHz)	Class A (dBuV)		Class B (dBuV)	
	Quasi-peak	Average	Quasi-peak	Average
0.15 -0.5	79.00	66.00	66 - 56 *	56 - 46 *
0.50 -5.0	73.00	60.00	56.00	46.00
5.0 -30.0	73.00	60.00	60.00	50.00

Note:

- (1) The tighter limit applies at the band edges.
- (2) The limit of " \* " marked band means the limitation decreases linearly with the logarithm of the frequency in the range.

The following table is the setting of the receiver

Receiver Parameters	Setting
Attenuation	10 dB
Start Frequency	0.15 MHz
Stop Frequency	30 MHz
IF Bandwidth	9 kHz

### 3.1.2 TEST PROCEDURE

- a. The EUT was placed 0.8 meters from the horizontal ground plane with EUT being connected to the power mains through a line impedance stabilization network (LISN). All other support equipments powered from additional LISN(s). The LISN provide 50 Ohm/ 50uH of coupling impedance for the measuring instrument.
- b. Interconnecting cables that hang closer than 40 cm to the ground plane shall be folded back and forth in the center forming a bundle 30 to 40 cm long.
- c. I/O cables that are not connected to a peripheral shall be bundled in the center. The end of the cable may be terminated, if required, using the correct terminating impedance. The overall length shall not exceed 1 m.
- d. LISN at least 80 cm from nearest part of EUT chassis.
- e. For the actual test configuration, please refer to the related Item –EUT Test Photos.

### 3.1.3 TEST SETUP

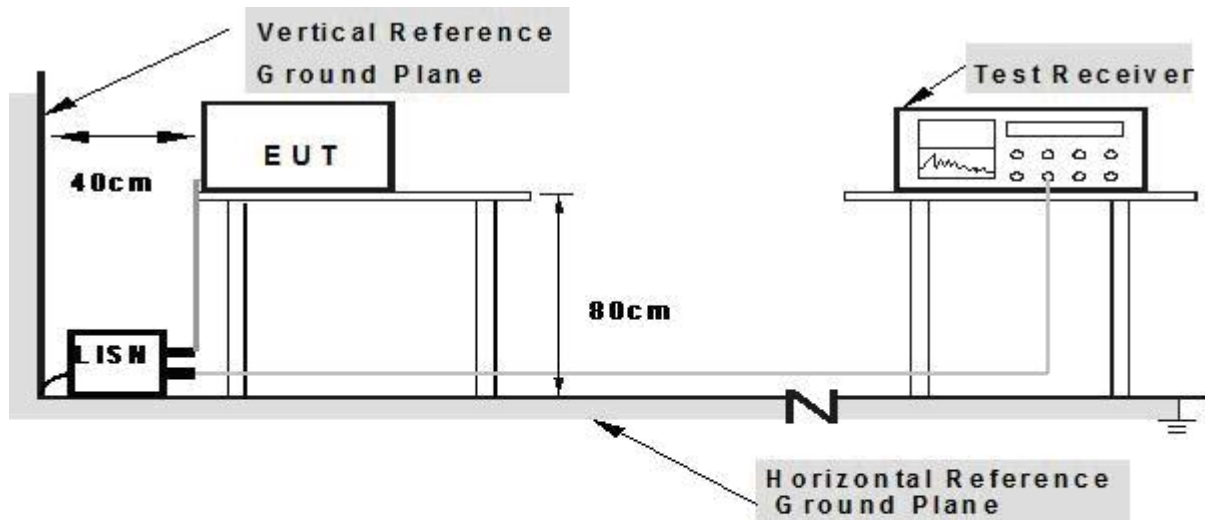

- Note: 1. Support units were connected to second LISN.**  
**2. Both of LISNs (AMN) are 80 cm from EUT and at least 80 from other units and other metal planes**

### 3.1.4 EUT OPERATING CONDITIONS

The EUT tested system was configured as the statements of 2.3 Unless otherwise a special operating condition is specified in the follows during the testing.

### 3.1.5 TEST RESULTS

EUT :	W8 Tablet	Model Name. :	8DTB37
Temperature :	26 °C	Relative Humidity :	54%
Pressure :	1010hPa	Test Date :	2014-09-20
Test Mode :	Mode 3	Phase :	L
Test Voltage :	DC 9V From ADAPTER AC 120V/60Hz		

Frequency (MHz)	Reading Level (dBμV)	Correct Factor (dB)	Measure-ment (dBμV)	Limits (dBμV)	Margin (dB)	Remark
0.1900	40.66	9.51	50.17	64.03	-13.86	QP
0.1900	19.65	9.51	29.16	54.03	-24.87	AVG
0.3300	33.99	9.50	43.49	59.45	-15.96	QP
0.3300	20.71	9.50	30.21	49.45	-19.24	AVG
0.4380	32.26	9.51	41.77	57.10	-15.33	QP
0.4380	18.04	9.51	27.55	47.10	-19.55	AVG
0.5340	30.12	9.51	39.63	56.00	-16.37	QP
0.5340	15.70	9.51	25.21	46.00	-20.79	AVG
2.9180	25.50	9.57	35.07	56.00	-20.93	QP
2.9180	11.66	9.57	21.23	46.00	-24.77	AVG
26.6020	35.20	10.15	45.35	60.00	-14.65	QP
26.6020	30.44	10.15	40.59	50.00	-9.41	AVG

Remark:

1. All readings are Quasi-Peak and Average values.
2. Factor = Insertion Loss + Cable Loss.

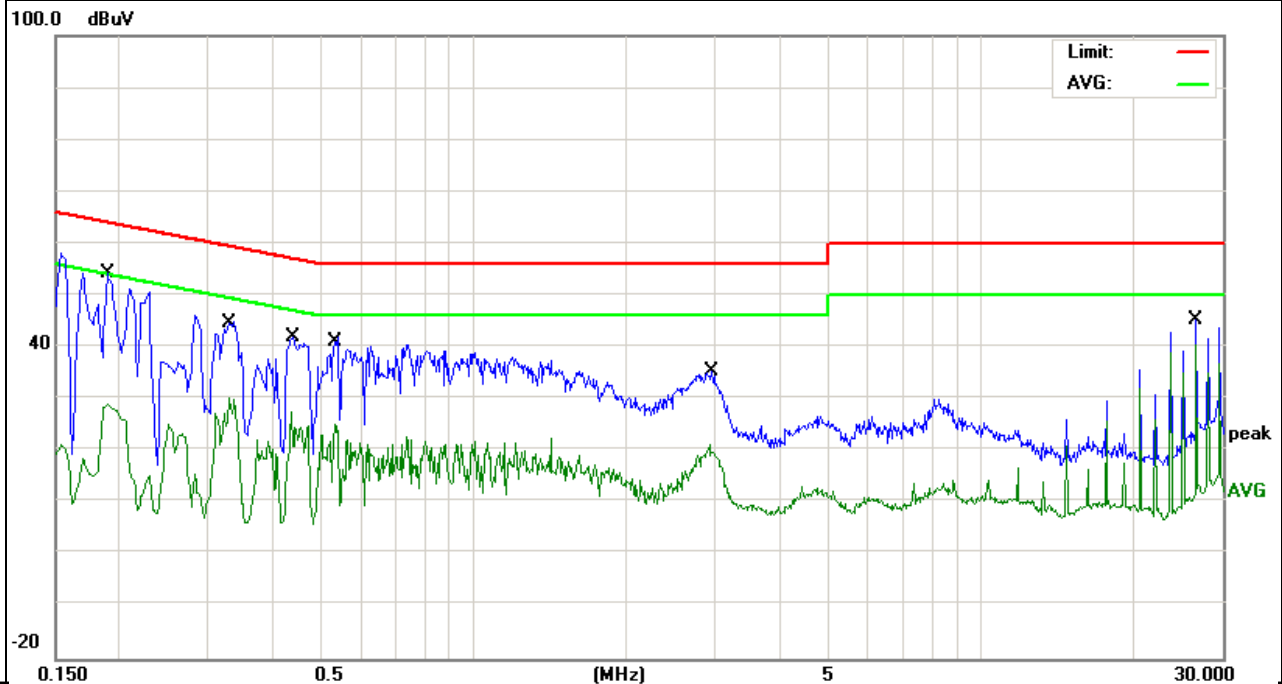

EUT :	W8 Tablet	Model Name. :	8DTB37
Temperature :	26 °C	Relative Humidity :	54%
Pressure :	1010hPa	Test Date :	2014-09-20
Test Mode :	Mode 3	Phase :	N
Test Voltage :	DC 9V From ADAPTER AC 120V/60Hz		

Frequency (MHz)	Reading Level (dBμV)	Correct Factor (dB)	Measure-ment (dBμV)	Limits (dBμV)	Margin (dB)	Remark
0.2020	40.72	9.50	50.22	63.52	-13.30	QP
0.2020	19.38	9.50	28.88	53.52	-24.64	AVG
0.3140	32.19	9.51	41.70	59.86	-18.16	QP
0.3140	18.15	9.51	27.66	49.86	-22.20	AVG
0.4780	31.15	9.53	40.68	56.37	-15.69	QP
0.4780	17.77	9.53	27.30	46.37	-19.07	AVG
2.8980	29.17	9.58	38.75	56.00	-17.25	QP
2.8980	9.72	9.58	19.30	46.00	-26.70	AVG
8.2979	22.88	9.70	32.58	60.00	-27.42	QP
8.2979	7.07	9.70	16.77	50.00	-33.23	AVG
26.6020	36.04	10.27	46.31	60.00	-13.69	QP
26.6020	32.25	10.27	42.52	50.00	-7.48	AVG

Remark:

1. All readings are Quasi-Peak and Average values.
2. Factor = Insertion Loss + Cable Loss.

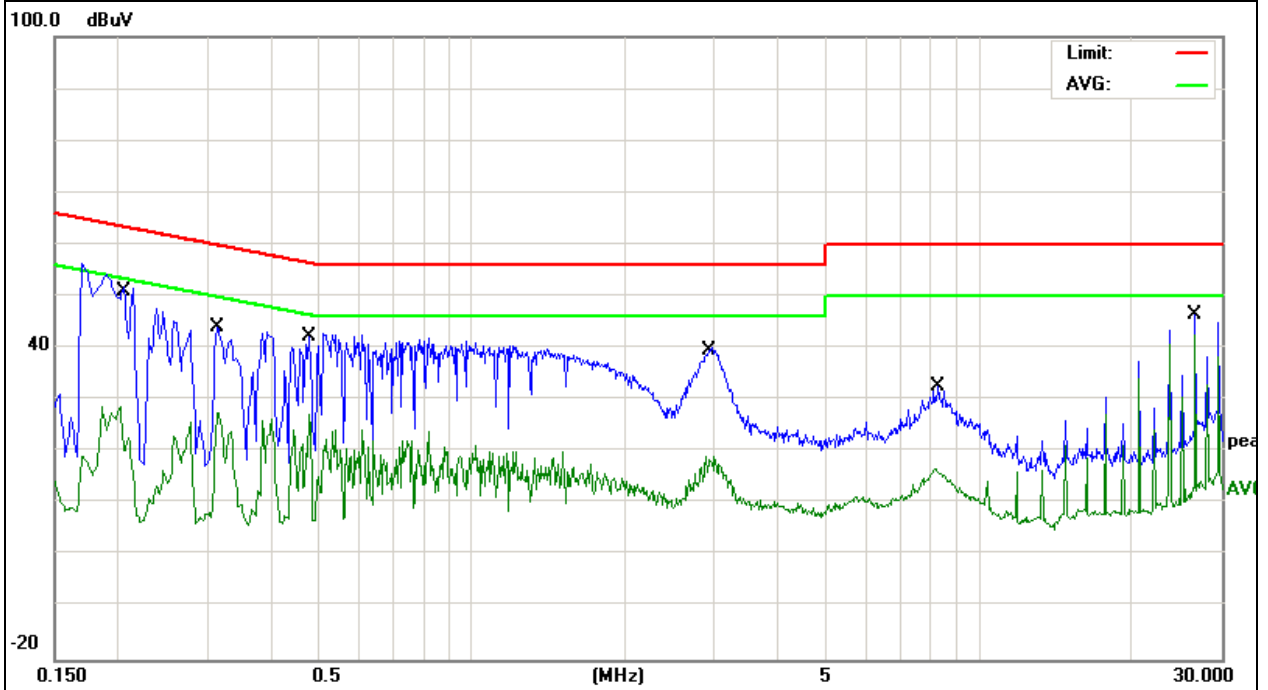

### 3.2 RADIATED EMISSION MEASUREMENT

#### 3.2.1 LIMITS OF RADIATED EMISSION MEASUREMENT

FREQUENCY (MHz)	Class A (at 10m)	Class B (at 3m)
	dBuV/m	dBuV/m
30 ~ 88	39.0	40.0
88 ~ 216	43.5	43.5
216 ~ 960	46.5	46.0
Above 960	49.5	54.0

Notes:

- (1) The limit for radiated test was performed according to as following:  
FCC PART 15B /ICES-003.
- (2) The tighter limit applies at the band edges.
- (3) Emission level (dBuV/m)=20log Emission level (uV/m).

#### 3.2.2 TEST PROCEDURE

##### Test Arrangement for Radiated Emissions up to 1 GHz

- a. The EUT was placed on the top of a rotating table 0.8 meters above the ground at an accredited test facility. The table was rotated 360 degrees to determine the position of the highest radiation.
- b. The EUT was set 3 meters away from the interference-receiving antenna, which was mounted on the top of a variable-height antenna tower.
- c. The antenna is a broadband antenna, and its height is varied from one meter to four meters above the ground to determine the maximum value of the field strength. Both horizontal and vertical polarizations of the antenna are set to make the measurement.
- d. For each suspected emission, the EUT was arranged to its worst case and then the antenna was tuned to heights from 1 meter to 4 meters and the rotatable table was turned from 0 degrees to 360 degrees to find the maximum reading.
- e. The test-receiver system was set to quasi-peak detect function and specified bandwidth with maximum hold mode when the test frequency is below 1 GHz.

Note: The resolution bandwidth and video bandwidth of test receiver/spectrum analyzer is 120kHz for quasi-peak detection (QP) at frequency below 1GHz.

##### Test Arrangement for Radiated Emissions above 1 GHz.

- a. The EUT was placed on the top of a rotating table 0.8 meters above the ground at an accredited chamber room. The table was rotated 360 degrees to determine the position of the highest radiation.
- b. The EUT was set 3 meters away from the interference-receiving antenna, which was mounted on the top of a variable-height antenna tower.
- c. The height of antenna can be varied from one meter to four meters, the height of adjustment depends on the EUT height and the antenna 3dB beamwidth both, to detect the maximum value of the field strength.Both horizontal and vertical polarizations of the antenna are set to make the measurement.
- d. For each suspected emission, the EUT was arranged to its worst case and then the antenna was tuned to heights and the rotatable table was turned from 0 degrees to 360 degrees to find

the maximum reading.

- e. The spectrum analyzer system was set to peak and average detect function and specified bandwidth with maximum hold mode when the test frequency is above 1 GHz

Note: For the hand-held device, the EUT should be measured for all 3 axes and only the worst case is recorded in the report

During the radiated emission test, the Spectrum Analyzer was set with the following configurations:

Frequency Band (MHz)	Function	Resolution bandwidth	Video Bandwidth
30 to 1000	QP	120 kHz	300 kHz
Above 1000	Peak	1 MHz	1 MHz
	Peak	1 MHz	10 Hz

### 3.2.3 TEST SETUP

#### (A) Radiated Emission Test Set-Up Frequency Below 1 GHz

For radiated emissions below 30MHz

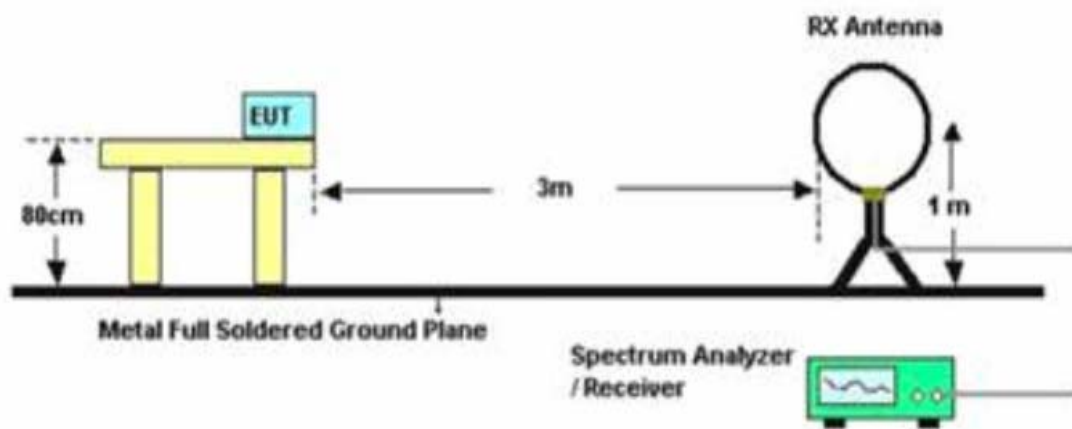



For Radiated Emission 30~1000MHz

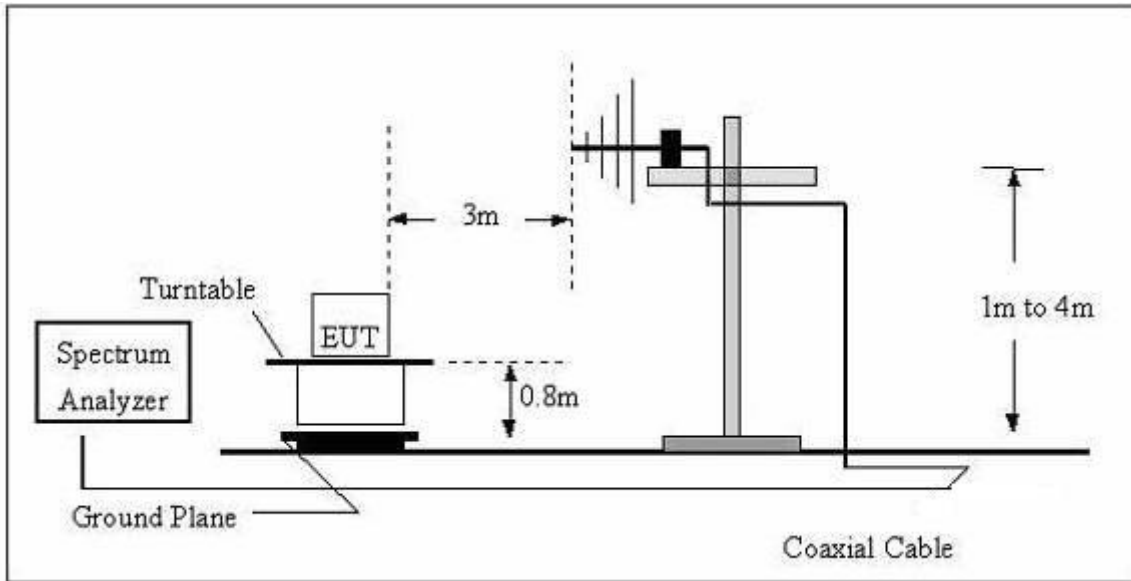

(B) Radiated Emission Test Set-Up Frequency Above 1GHz

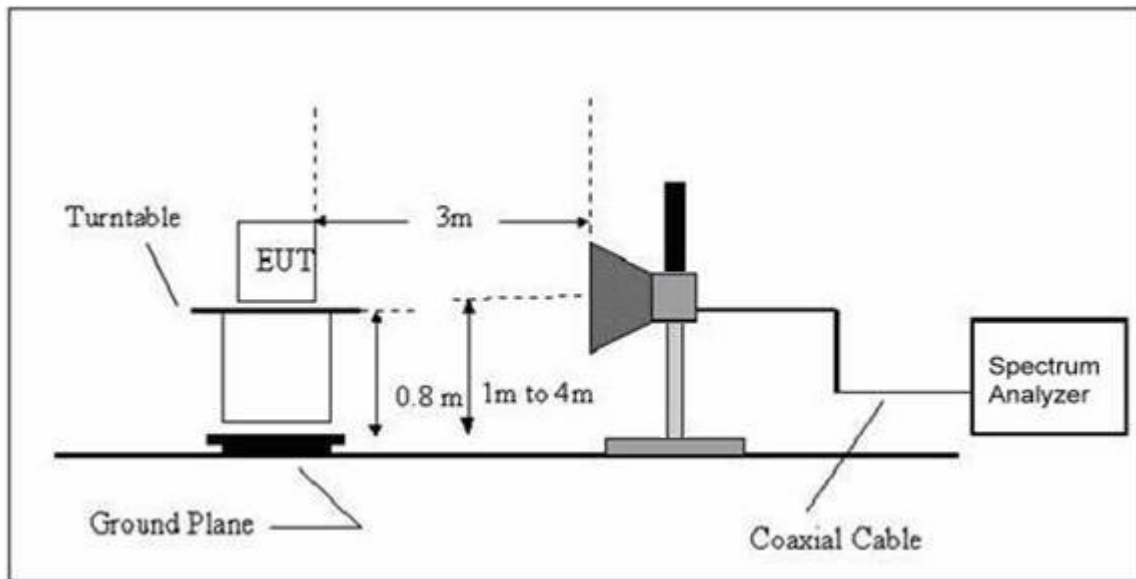

**3.2.4 EUT OPERATING CONDITIONS**

The EUT tested system was configured as the statements of **2.3** Unless otherwise a special operating condition is specified in the follows during the testing.

3.2.5 TEST RESULTS

TEST RESULTS (Below 30 MHz)

EUT :	W8 Tablet	Model Name :	8DTB37
Temperature :	20 °C	Relative Humidity :	48%
Pressure :	1010 hPa	Test Voltage :	---
Test Mode :	TX	Polarization :	---

Freq.	Reading	Limit	Margin	State
(MHz)	(dBuV/m)	(dBuV/m)	(dB)	P/F
--	--	--	--	P
--	--	--	--	P

**NOTE:**

The amplitude of spurious emissions which are attenuated by more than 20dB below the permissible value has no need to be reported.

Distance extrapolation factor =  $20 \log(\text{specific distance}/\text{test distance})$ (dB);

Limit line = specific limits(dBuv) + distance extrapolation factor.

TEST RESULTS (30~1000 MHz)

EUT :	W8 Tablet	Model Name :	8DTB37
Temperature :	24 °C	Relative Humidity :	54%
Pressure :	1010 hPa	Test Date :	2014-09-20
Test Mode :	Mode 3	Polarization :	Horizontal
Test Power :	DC 9V From ADAPTER AC 120V/60Hz		

Freq. (MHz)	Reading (dBuV)	Factor (dBuV)	Measurement (dBuV)	Limit (dBuV)	Over (dB)	Remark
51.6613	21.26	10.22	31.48	40.00	-8.52	QP
79.8002	23.55	5.85	29.40	40.00	-10.60	QP
172.5988	19.78	10.57	30.35	43.50	-13.15	QP
317.701	21.06	14.89	35.95	46.00	-10.05	QP
668.1422	7.60	23.91	31.51	46.00	-14.49	QP
922.5157	8.29	27.15	35.44	46.00	-10.56	QP

Remark:

Factor = Antenna Factor + Cable Loss - Amplifier.

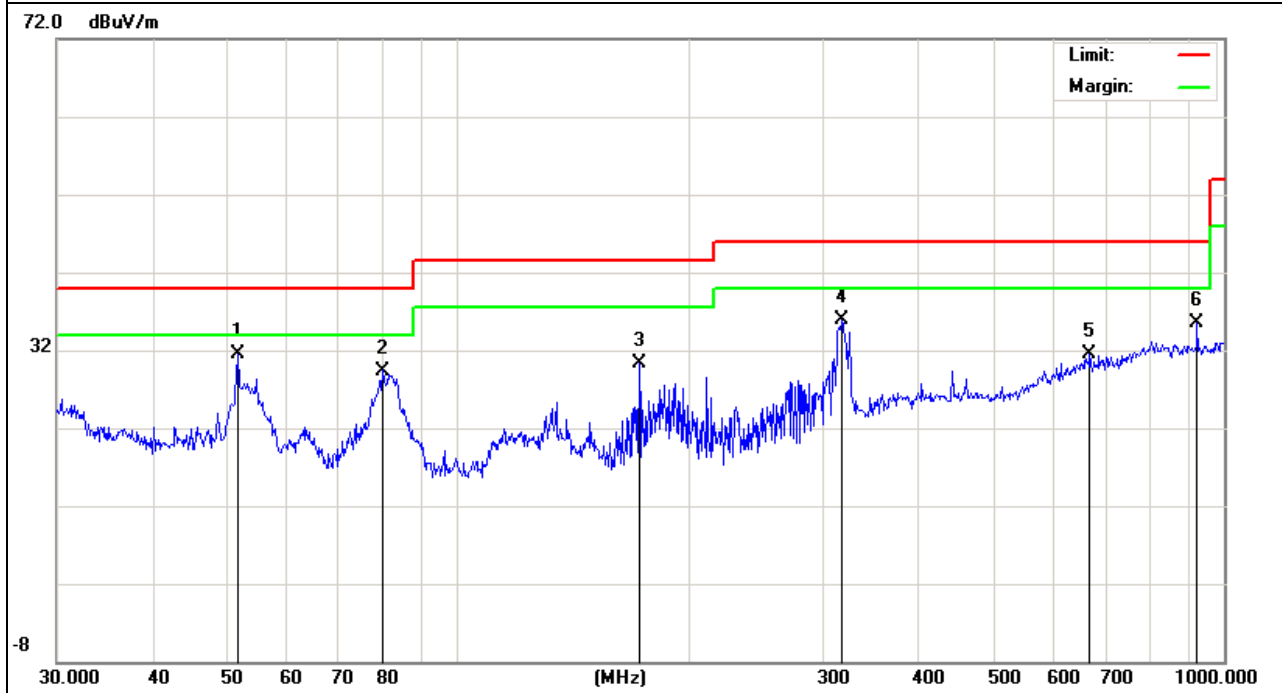

EUT :	W8 Tablet	Model Name :	8DTB37
Temperature :	24 °C	Relative Humidity :	54%
Pressure :	1010 hPa	Test Date :	2014-09-20
Test Mode :	Mode 3	Polarization :	Vertical
Test Power :	DC 9V From Notebook AC 120V/60Hz		

Freq. (MHz)	Reading (dBuV)	Factor (dBuV)	Measurement (dBuV)	Limit (dBuV)	Over (dB)	Remark
32.4059	14.94	18.11	33.05	40.00	-6.95	QP
48.6719	24.62	11.02	35.64	40.00	-4.36	QP
113.7142	25.09	10.75	35.84	43.50	-7.66	QP
134.5592	24.48	11.67	36.15	43.50	-7.35	QP
312.1792	16.19	14.66	30.85	46.00	-15.15	QP
900.1471	11.97	27.01	38.98	46.00	-7.02	QP

Remark:

1. All readings are Peak and Average values.
2. Factor = Antenna Factor + Cable Loss - Amplifier.
3. N/A means All Data have pass Limit

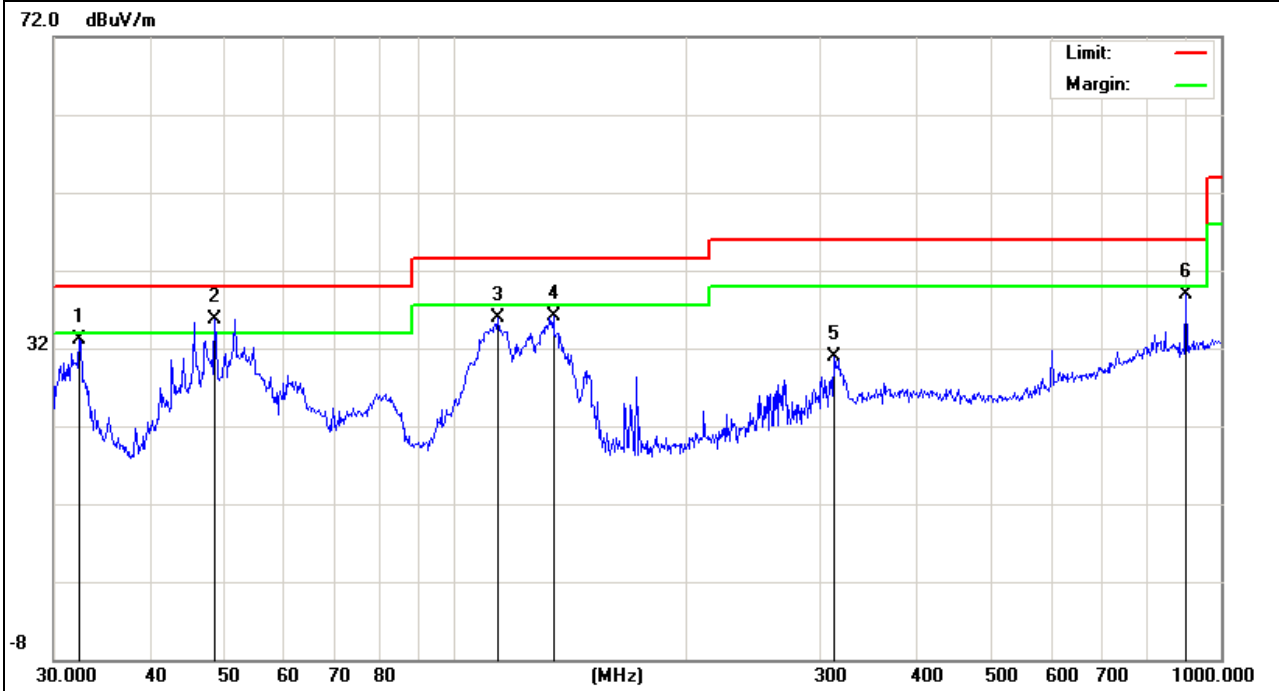

3.2.6 TEST RESULTS(1000~12400MHz)

Polar (H/V)	Frequency	Meter Reading	Factor	Emission Level	Limits	Margin	Remark
	(MHz)	(dBm)	(dB)	(dBm)	(dBm)	(dB)	
V	1112.888	63.82	-17.44	46.38	74	-27.62	peak
V	1112.888	41.42	-17.44	23.98	54	-30.02	AVG
V	1924.979	62.09	-12.47	49.62	74	-24.38	peak
V	1924.979	40.64	-12.47	28.17	54	-25.83	AVG
V	2250.365	61.63	-12.22	49.41	74	-24.59	peak
V	2250.365	39.04	-12.22	26.82	54	-27.18	AVG
V	2650.172	61.75	-10.95	50.80	74	-23.2	peak
V	2650.172	39.36	-10.95	28.41	54	-25.59	AVG
V	2850.26	61.01	-11.13	49.88	74	-24.12	peak
V	2850.26	41.00	-11.13	29.87	54	-24.13	AVG
V	3975.074	57.83	-5.15	52.68	74	-21.32	peak
V	3975.074	36.41	-5.15	31.26	54	-22.74	AVG
H	1313.378	58.65	-16.6	42.05	74	-31.95	peak
H	1313.378	38.46	-16.6	21.86	54	-32.14	AVG
H	1513.004	59.04	-15.67	43.37	74	-30.63	peak
H	1513.004	39.23	-15.67	23.56	54	-30.44	AVG
H	1924.893	57.41	-12.47	44.94	74	-29.06	peak
H	1924.893	36.84	-12.47	24.37	54	-29.63	AVG
H	2700.272	57.25	-10.78	46.47	74	-27.53	peak
H	2700.272	35.97	-10.78	25.19	54	-28.81	AVG
H	3788.057	53.89	-6.42	47.47	74	-26.53	peak
H	3788.057	32.29	-6.42	25.87	54	-28.13	AVG
H	4762.901	51.75	-2.72	49.03	74	-24.97	peak
H	4762.901	30.69	-2.72	27.97	54	-26.03	AVG

**Remark:**

Absolute Level= ReadingLevel+ Factor, Margin= Absolute Level - Limit

**4. EUT TEST PHOTO**

**Radiated Measurement Photos**

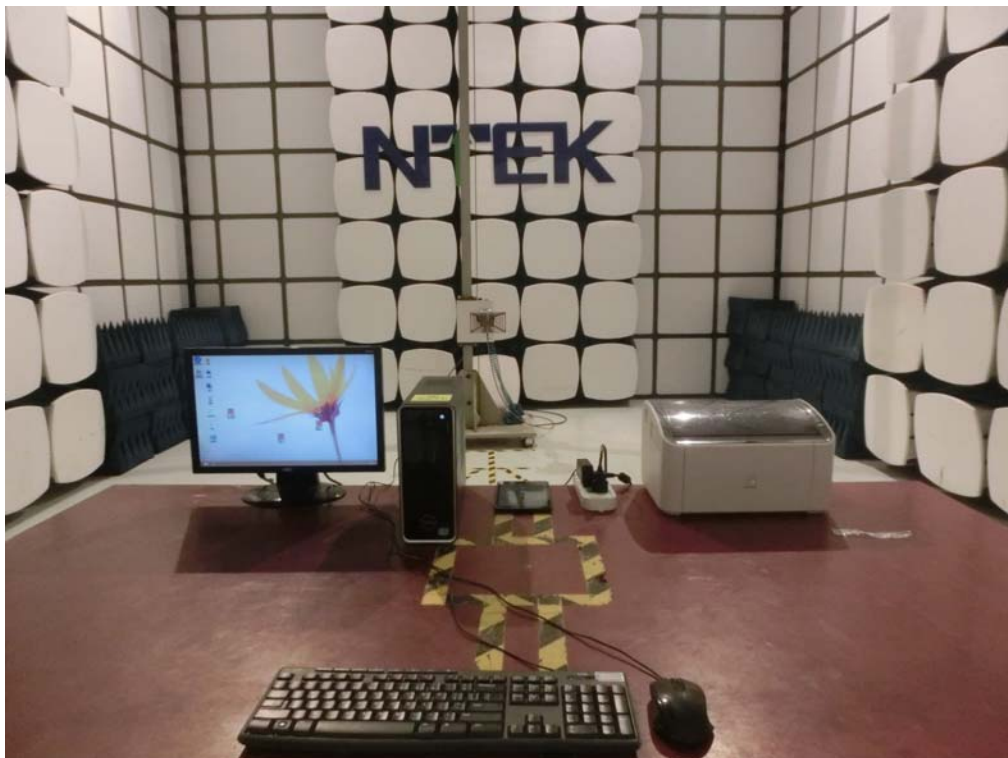

**Conducted Measurement Photos**

