



Shenzhen CTL Testing Technology Co., Ltd.
Tel: +86-755-89486194 Fax: +86-755-26636041

TEST REPORT

FCC Part 15.247 & RSS-210

Report Reference No.: CTL1401100055-WF

Compiled by

(position+printed name+signature) : File administrators Jacky Chen

Jacky Chen

Name of the organization performing the tests

Test Engineer Tracy Qi

Tracy Qi

(position+printed name+signature) :

Approved by

(position+printed name+signature) : Manager Tracy Qi

Tracy Qi

Date of issue: Jan. 21, 2014

Test Firm: Shenzhen CTL Testing Technology Co., Ltd.

Address : Floor 1-A, Baisha Technology Park, No.3011, Shahehexi Road, Nanshan District, Shenzhen, China 518055

Applicant's name: Kobian Canada Inc

Address : 560 Denison Street, Unit #5, Markham, Ontario, L3R 2M8, Canada

Test specification:

Standard : FCC Part 15.247: Operation within the bands 902–928 MHz, 2400–2483.5 MHz, and 5725–5850 MHz.

RSS-210 Issue 8 (2010): Licence-exempt Radio Apparatus (All Frequency Bands): Category I Equipment

TRF Originator: Shenzhen CTL Testing Technology Co., Ltd.

Master TRF: Dated 2014-01

Shenzhen CTL Testing Technology Co., Ltd. All rights reserved.

This publication may be reproduced in whole or in part for non-commercial purposes as long as the Shenzhen CTL Testing Technology Co., Ltd. is acknowledged as copyright owner and source of the material. Shenzhen CTL Testing Technology Co., Ltd. takes no responsibility for and will not assume liability for damages resulting from the reader's interpretation of the reproduced material due to its placement and context.

Test item description : HS-7DTB26-4GB

FCC ID: YH5-7DTB26

IC: 8012A-7DTB26

Trade Mark : Hipstreet

Model/Type reference : HS-7DTB26-4GB

Work frequency : 802.11b/g/n: 2412~2462MHz, 802.11n(40MHz): 2422~2452

Type of modulation : 802.11b DSSS, 802.11g/n: OFDM

Data Rate : 802.11b: 1/2/5.5/11 Mbps, 802.11g: 6/9/12/18/24/36/48/54 Mbps
802.11n: up to 150 Mbps

Antenna Gain : -0.5 dBi

Antenna type : Internal

Result : Positive

TEST REPORT

Test Report No. :	CTL1401100055-WF	Jan. 21, 2014
		Date of issue

Equipment under Test : **HS-7DTB26-4GB**

Model /Type : HS-7DTB26-4GB

Applicant : **Kobian Canada Inc**

Address : 560 Denison Street, Unit #5, Markham, Ontario, L3R 2M8, Canada

Manufacturer : **Wing Ming Electronics Limited**

Address : Suite 1306, A Block, Tianan Building, Renmin South Road, Louhu, Shenzhen, China

Test Result according to the standards on page 4:	Positive
--	-----------------

The test report merely corresponds to the test sample.
It is not permitted to copy extracts of these test result without the written permission of the test laboratory.

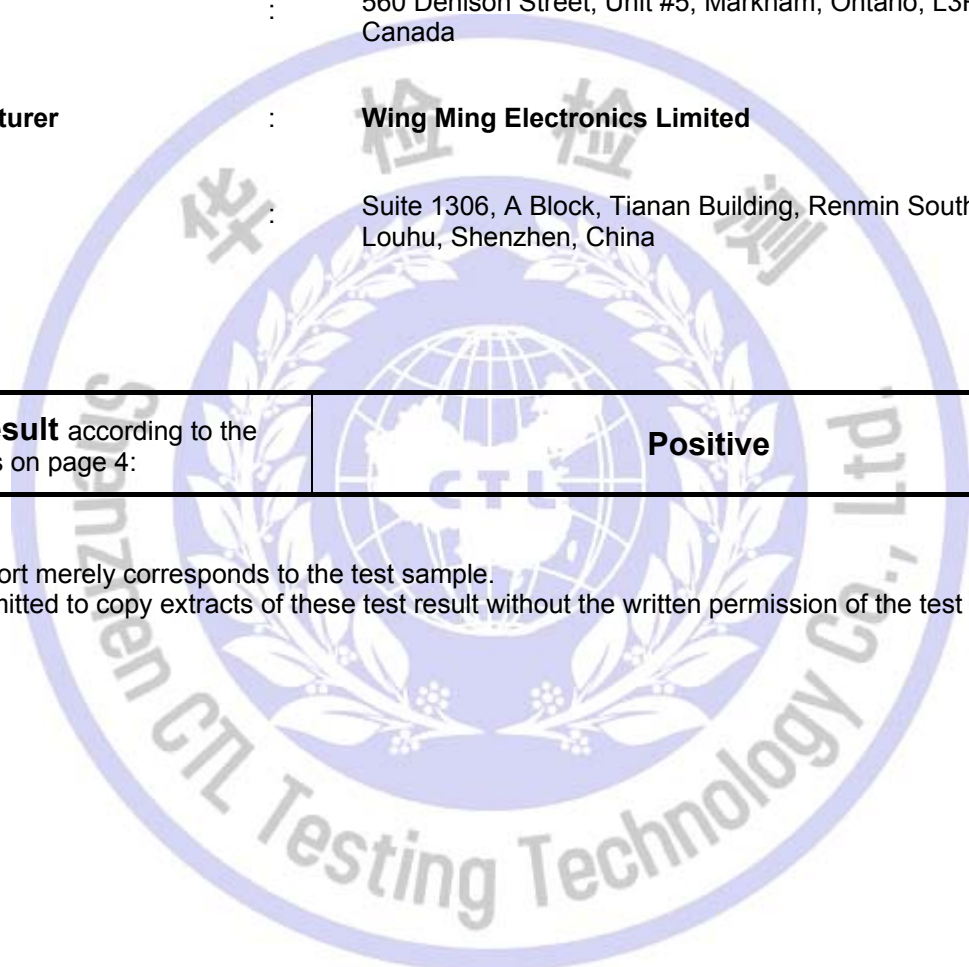

Contents

1.	<u>TEST STANDARDS.....</u>	4
2.	<u>SUMMARY</u>	5
2.1.	General Remarks	5
2.2.	Equipment Under Test	5
2.3.	Short description of the Equipment under Test (EUT)	5
2.4.	EUT operation mode	5
2.5.	EUT configuration	6
2.6.	NOTE	6
2.7.	Related Submittal(s) / Grant (s)	6
2.8.	Modifications	6
3.	<u>TEST ENVIRONMENT</u>	7
3.1.	Address of the test laboratory	7
3.2.	Test Facility	7
3.3.	Environmental conditions	7
3.4.	Configuration of Tested System	7
3.5.	Statement of the measurement uncertainty	8
3.6.	Equipments Used during the Test	8
3.7.	Summary of Test Result	9
4.	<u>TEST CONDITIONS AND RESULTS.....</u>	10
4.1.	Conducted Emissions Test	10
4.2.	Radiated Emission Test	13
4.3.	6dB and 99% Bandwidth Measurement	21
4.4.	Maximum Peak Output Power	37
4.5.	Band Edge Measurement	38
4.6.	Power Spectral Density Measurement	55
4.7.	Spurious RF Conducted Emission	64
4.8.	Operation Frequency Range of 20dB Bandwidth	72
4.9.	Antenna Requirement	77
4.10.	RF Exposure	78
5.	<u>TEST SETUP PHOTOS OF THE EUT</u>	79
6.	<u>EXTERNAL AND INTERNAL PHOTOS OF THE EUT</u>	81

1. TEST STANDARDS

The tests were performed according to following standards:

[FCC Part 15.247](#): Frequency Hopping, Direct Spread Spectrum and Hybrid Systems that are in operation within the bands of 902-928 MHz, 2400-2483.5 MHz, and 5725-5850 MHz.

[RSS-210 Issue 8 \(2010\)](#): Licence-exempt Radio Apparatus (All Frequency Bands): Category I Equipment

[ANSI C63.10-2009](#): American National Standard for Testing Unlicensed Wireless Devices.

[ANSI C63.4-2009](#)

[KDB Publication No. 558074 D01 v03r01 Guidance on Measurements for Digital Transmission Systems](#)



2. SUMMARY

2.1. General Remarks

Date of receipt of test sample	:	Jan. 16, 2014
Testing commenced on	:	Jan. 17, 2014
Testing concluded on	:	Jan. 21, 2014

2.2. Equipment Under Test

Power supply system utilised

Power supply voltage	:	<input checked="" type="radio"/> 120V / 60 Hz	<input type="radio"/> 115V / 60Hz
		<input type="radio"/> 12 V DC	<input type="radio"/> 24 V DC
		<input checked="" type="radio"/> Other (specified in blank below)	

DC 3.7V from battery

Description of the test mode

IEEE 802.11b/g/n: Thirteen channels are provided to the EUT, but only eleventh channels used for USA.

Channel	Frequency(MHz)	Channel	Frequency(MHz)
1	2412	8	2447
2	2417	9	2452
3	2422	10	2457
4	2427	11	2462
5	2432		
6	2437		
7	2442		

2.3. Short description of the Equipment under Test (EUT)

The HS-7DTB26-4GB is a Tablet PC support wifi function.

For more details, refer to the user's manual of the EUT.

Serial number: Prototype

2.4. EUT operation mode

Test Mode:

- The EUT has been tested under normal operating condition.
- Test program used to control the EUT for staying in continuous transmitting and receiving mode is programmed. Channel low (2412MHz), mid (2442MHz) and high (2462MHz) with highest data rate are chosen for full testing.
- Test Mode:

Test Mode(TM)	Description	Remark
1	Transmitting	802.11 b
2	Transmitting	802.11 g
3	Transmitting	802.11 n HT20
4	Transmitting	802.11 n HT40

2.5. EUT configuration

The following peripheral devices and interface cables were connected during the measurement:

○ - supplied by the manufacturer

● - supplied by the lab

● Notebook PC

Manufacturer : DELL

Model No. : PP18L

2.6. NOTE

1. The EUT is an 802.11b/g/n Tablet PC, The functions of the EUT listed as below:

	Test Standards	Reference Report
WLAN 802.11b/g, 802.11n	FCC Part 15 Subpart C (Section15.247)	CTL1401100055-WF

2. The frequency bands used in this EUT are listed as follows:

Frequency Band(MHz)	2400-2483.5	5150-5350	5470-5725	5725-5850
802.11b	√	—	—	—
802.11g	√	—	—	—
802.11n(20MHz)	√	—	—	—
802.11n(40MHz)	√	—	—	—

3. The EUT incorporates a SISO function, Physically, the EUT provides two completed transmitter and two completed receivers.

Modulation Mode	TX Function
802.11b	1TX
802.11g	1TX
802.11n (20MHz)	1TX
802.11n (40MHz)	1TX

2.7. Related Submittal(s) / Grant (s)

This submittal(s) (test report) is intended for FCC ID: YH5-7DTB26 and IC: 8012A-7DTB26 filing to comply with of the FCC Part 15.247 and RSS-210 Rules.

2.8. Modifications

No modifications were implemented to meet testing criteria.

3. TEST ENVIRONMENT

3.1. Address of the test laboratory

Shenzhen CTL Testing Technology Co., Ltd.
 Floor 1-A, Baisha Technology Park, No. 3011, Shahexi Road, Nanshan, Shenzhen 518055 China.

The sites are constructed in conformance with the requirements of ANSI C63.7, ANSI C63.4 (2009) and CISPR Publication 22.

3.2. Test Facility

The test facility is recognized, certified, or accredited by the following organizations:

IC Registration No.: 9618B

The 3m alternate test site of Shenzhen CTL Testing Technology Co., Ltd. EMC Laboratory has been registered by Certification and Engineer Bureau of Industry Canada for the performance of with Registration No.: 9618B on November 13, 2013.

FCC-Registration No.: 970318

Shenzhen CTL Testing Technology Co., Ltd. EMC Laboratory has been registered and fully described in a report filed with the (FCC) Federal Communications Commission. The acceptance letter from the FCC is maintained in our files. Registration 970318, December 19, 2013.

3.3. Environmental conditions

During the measurement the environmental conditions were within the listed ranges:

Temperature:	<u>15-35 ° C</u>
Humidity:	<u>30-60 %</u>
Atmospheric pressure:	<u>950-1050mbar</u>

3.4. Configuration of Tested System

Fig. 2-1 Configuration of Tested System

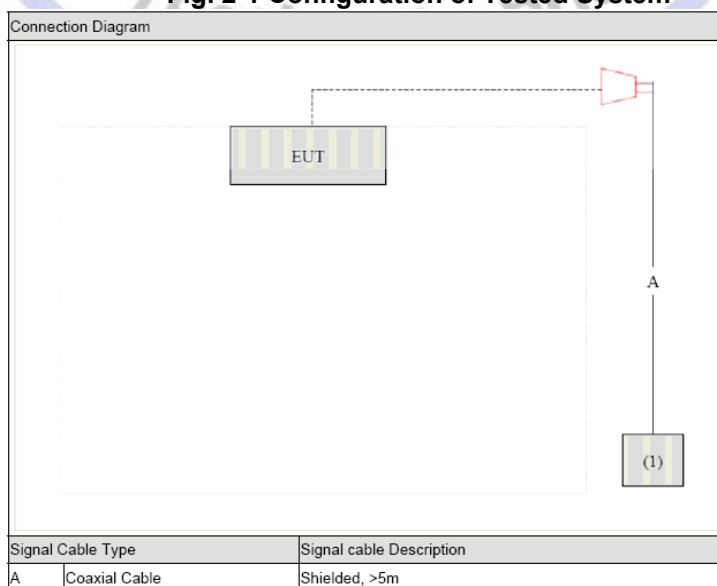

3.5. Statement of the measurement uncertainty

The data and results referenced in this document are true and accurate. The reader is cautioned that there may be errors within the calibration limits of the equipment and facilities. The measurement uncertainty was calculated for all measurements listed in this test report acc. to CISPR 16 - 4 „Specification for radio disturbance and immunity measuring apparatus and methods – Part 4: Uncertainty in EMC Measurements“ and is documented in the Shenzhen CTL Testing Technology Co., Ltd. quality system acc. to DIN EN ISO/IEC 17025. Furthermore, component and process variability of devices similar to that tested may result in additional deviation. The manufacturer has the sole responsibility of continued compliance of the device.

Hereafter the best measurement capability for CTL laboratory is reported:

Test	Range	Measurement Uncertainty	Notes
Radiated Emission	30~1000MHz	4.10dB	(1)
Radiated Emission	1~26.5GHz	4.32dB	(1)
Conducted Disturbance	0.15~30MHz	3.20dB	(1)

This uncertainty represents an expanded uncertainty expressed at approximately the 95% confidence level using a coverage factor of k=2.

3.6. Equipments Used during the Test

Test Equipment	Manufacturer	Model No.	Serial No.	Calibration Date	Calibration Due Date
Bilog Antenna	Sunol Sciences Corp.	JB1	A061713	2013/07/12	2014/07/11
EMI Test Receiver	R&S	ESCI	103710	2013/07/10	2014/07/09
Spectrum Analyzer	Agilent	E4407B	MY45108355	2013/07/06	2014/07/05
Controller	EM Electronics	Controller EM 1000	N/A	2013/07/06	2014/07/05
Horn Antenna	Sunol Sciences Corp.	DRH-118	A062013	2013/07/12	2014/07/11
Horn Antenna	SCHWARZBECK	BBHA9170	1562	2013/07/12	2014/07/11
Active Loop Antenna	SCHWARZBECK	FMZB1519	1519-037	2013/07/12	2014/07/11
LISN	R&S	ENV216	101316	2013/07/10	2014/07/09
LISN	SCHWARZBECK	NSLK8127	8127687	2013/07/10	2014/07/09
Microwave Preamplifier	HP	8349B	3155A00882	2013/07/10	2014/07/09
Amplifier	HP	8447D	3113A07663	2013/07/10	2014/07/09
Transient Limiter	Com-Power	LIT-153	532226	2013/07/10	2014/07/09
Radio Communication Tester	R&S	CMU200	3655A03522	2013/07/06	2014/07/05
Temperature/Humidity Meter	zhicheng	ZC1-2	22522	2013/07/10	2014/07/09
SIGNAL GENERATOR	HP	8647A	3200A00852	2013/07/10	2014/07/09
Wideband Peak Power Meter	Anritsu	ML2495A	220.23.35	2013/07/06	2014/07/05
Climate Chamber	ESPEC	EL-10KA	A20120523	2013/07/06	2014/07/05
High-Pass Filter	K&L	9SH10-2700/X12750-O/O	/	2013/07/06	2014/07/05
High-Pass Filter	K&L	41H10-1375/U12750-O/O	/	2013/07/06	2014/07/05

3.7. Summary of Test Result

FCC PART 15/ RSS-210		
FCC Part 15.207 / RSS-Gen Section 7.7.2	AC Power Conducted Emission	PASS
FCC Part 15.247(a)(2) / RSS-210 Annex A8.2	6dB Bandwidth	PASS
RSS-Gen Section 4.6.1	99% Bandwidth	PASS
FCC Part 15.247(d) / RSS-210 Annex A8.5	Spurious RF Conducted Emission	PASS
FCC Part 15.247(b) / RSS-210 Annex A8.4	Maximum Peak Output Power	PASS
FCC Part 15.247(e) / RSS-210 Annex A8.2	Power Spectral Density	PASS
FCC Part 15.109/ 15.205/ 15.209 / RSS-Gen Table 2&5&6	Radiated Emissions	PASS
FCC Part 15.247(d) / RSS-210 Annex A8.5	Band Edge Compliance of RF Emission	PASS
FCC Part 15.203/15.247 (b)	Antenna Requirement	PASS

Remark: The measurement uncertainty is not included in the test result.

Preliminary tests were performed in different data rate to find the worst radiated emission. The data rate shown in the table below is the worst-case rate with respect to the specific test item. Investigation has been done on all the possible configurations for searching the worst cases. The following table is a list of the test modes shown in this test report.

Test Items	Mode	Data Rate	Channel
AC Power Conducted Emission	Normal Link	11 Mbps	1
Maximum Peak Conducted Output Power Power Spectral Density 6dB Bandwidth Spurious RF conducted emission	11b/DSSS	11 Mbps	1/6/11
	11g/OFDM	54 Mbps	1/6/11
	11n(20MHz)/OFDM	65Mbps	1/6/11
	11n(40MHz)/OFDM	150Mbps	3/6/9
Radiated Emission 30MHz~1GHz	11b/DSSS	11 Mbps	1/6/11
	11g/OFDM	54 Mbps	1/6/11
	11n(20MHz)/OFDM	65Mbps	1/6/11
	11n(40MHz)/OFDM	150Mbps	3/6/9
Radiated Emission 1GHz~10th Harmonic	11b/DSSS	11 Mbps	1/6/11
	11g/OFDM	54 Mbps	1/6/11
	11n(20MHz)/OFDM	65Mbps	1/6/11
	11n(40MHz)/OFDM	150Mbps	3/6/9
Band Edge Compliance of RF Emission	11b/DSSS	11 Mbps	1/11
	11g/OFDM	54 Mbps	1/11
	11n(20MHz)/OFDM	65Mbps	1/11
	11n(40MHz)/OFDM	150Mbps	3/9

Note1: According exploratory test, EUT will have maximum output power in those data rate, so those data rate were used for all test.

4. TEST CONDITIONS AND RESULTS

4.1. Conducted Emissions Test

TEST CONFIGURATION

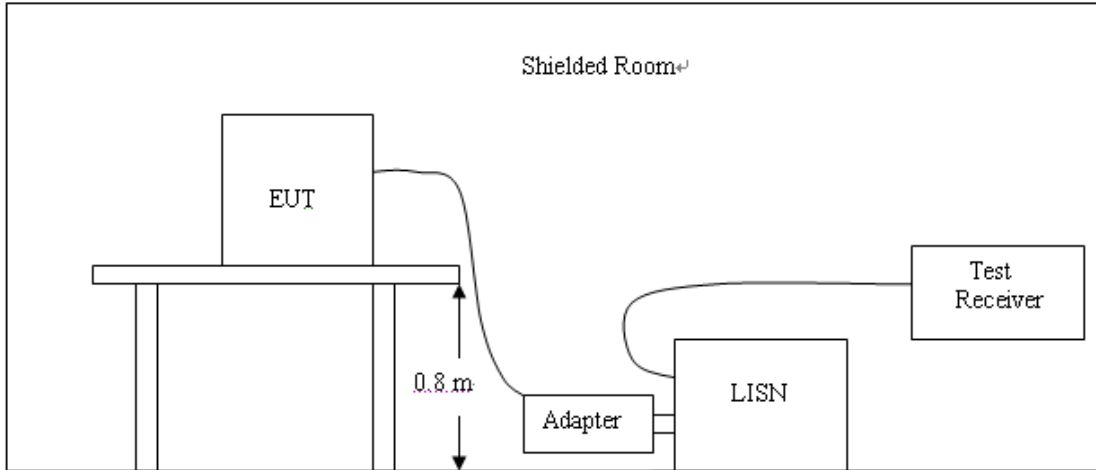

TEST PROCEDURE

For unintentional device, according to § 15.107(a) Line Conducted Emission Limits is as following:

Frequency (MHz)	Maximum RF Line Voltage (dBµV)			
	CLASS A		CLASS B	
	Q.P.	Ave.	Q.P.	Ave.
0.15 - 0.50	79	66	66-56*	56-46*
0.50 - 5.00	73	60	56	46
5.00 - 30.0	73	60	60	50

* Decreasing linearly with the logarithm of the frequency

For intentional device, according to §15.207(a) Line Conducted Emission Limit is same as above table.

1. Please follow the guidelines in ANSI C63.4-2009.
2. The EUT was placed 0.4 meter from the conducting wall of the shielding room was kept at least 80 centimeters from any other grounded conducting surface.
3. Connect EUT to the power mains through a line impedance stabilization network (LISN).
4. All the support units are connecting to the other LISN.
5. The LISN provides 50 ohm coupling impedance for the measuring instrument.
6. The FCC states that a 50 ohm, 50 microhenry LISN should be used.
7. Both sides of AC line were checked for maximum conducted interference.
8. The frequency range from 150 kHz to 30 MHz was searched.
9. Set the test-receiver system to Peak Detect Function and specified bandwidth with Maximum Hold Mode.

The RBW/VBW for 150KHz to 30MHz: 9KHz

TEST RESULTS

SCAN TABLE: "Voltage (9K-30M) FIN"

Short Description: 150K-30M Voltage

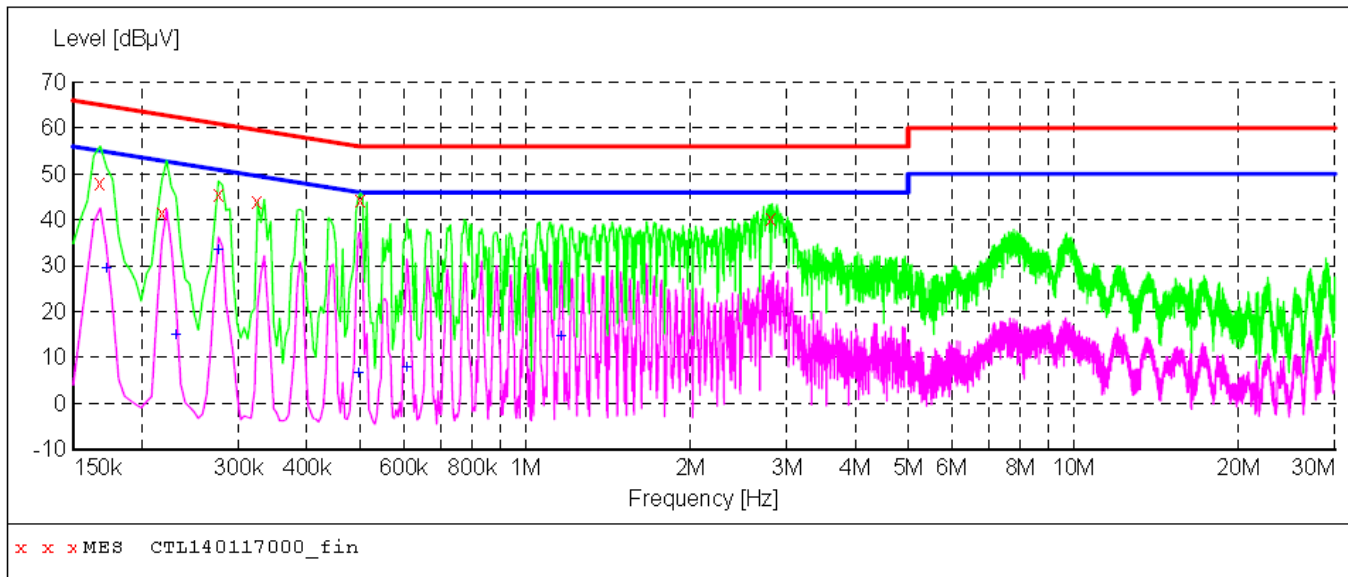

MEASUREMENT RESULT: "CTL140117000_fin"

1/17/2014 9:43AM

Frequency MHz	Level dBµV	Transd dB	Limit dBµV	Margin dB	Detector	Line	PE
0.168000	48.00	9.8	65	17.1	QP	N	GND
0.217500	41.40	9.8	63	21.5	QP	N	GND
0.276000	45.60	9.8	61	15.3	QP	N	GND
0.325000	44.00	9.8	61	17.0	QP	N	GND
0.501000	44.20	9.8	56	11.8	QP	N	GND
2.818500	40.40	9.9	56	15.6	QP	N	GND

MEASUREMENT RESULT: "CTL140117000_fin2"

1/17/2014 9:35AM

Frequency MHz	Level dBµV	Transd dB	Limit dBµV	Margin dB	Detector	Line	PE
0.172500	29.60	9.8	55	25.2	AV	N	GND
0.231000	15.00	9.8	52	37.4	AV	N	GND
0.276000	33.60	9.8	51	17.3	AV	N	GND
0.496500	6.60	9.8	46	39.5	AV	N	GND
0.609000	7.80	9.8	46	38.2	AV	N	GND
1.162500	14.70	9.8	46	31.3	AV	N	GND

SCAN TABLE: "Voltage (9K-30M) FIN"

Short Description: 150K-30M Voltage

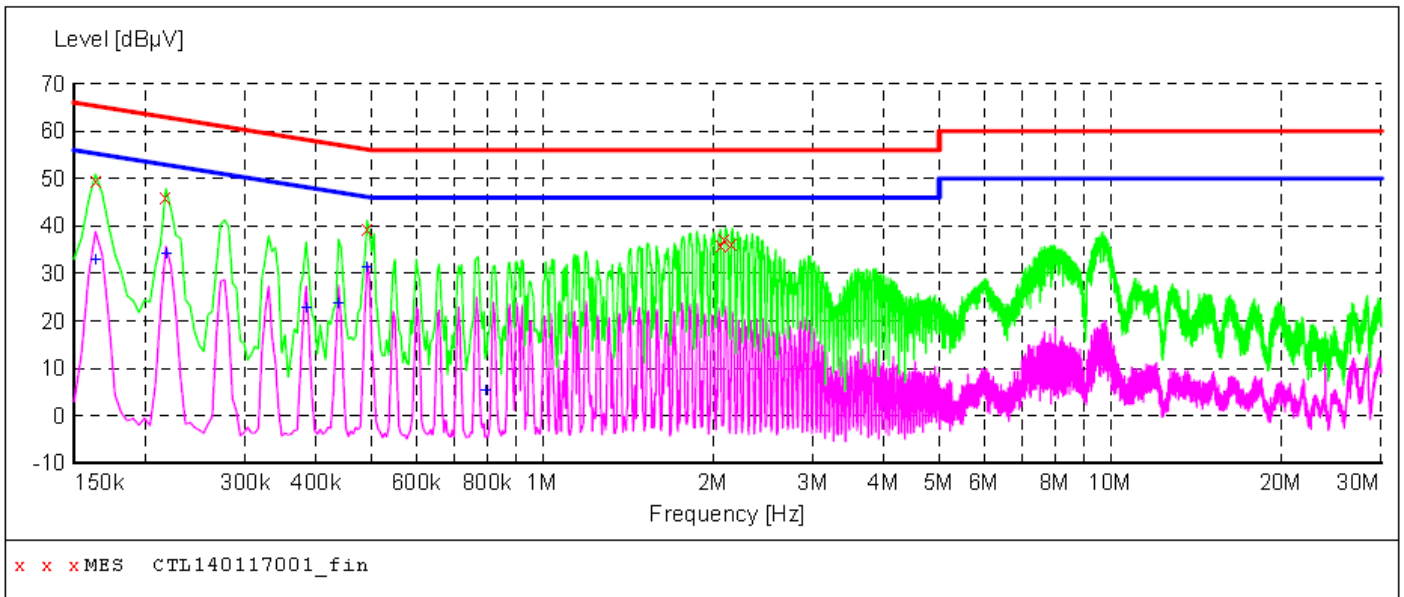

MEASUREMENT RESULT: "CTL140117001_fin"

1/17/2014 9:41AM

Frequency MHz	Level dBµV	Transd dB	Limit dBµV	Margin dB	Detector	Line	PE
0.163500	49.50	9.8	65	15.8	QP	L1	GND
0.217500	46.20	9.8	63	16.7	QP	L1	GND
0.492000	39.50	9.8	56	16.6	QP	L1	GND
2.071500	36.00	9.8	56	20.0	QP	L1	GND
2.094000	37.20	9.8	56	18.8	QP	L1	GND
2.152500	36.30	9.9	56	19.7	QP	L1	GND

MEASUREMENT RESULT: "CTL140117001_fin2"

1/17/2014 9:41AM

Frequency MHz	Level dBµV	Transd dB	Limit dBµV	Margin dB	Detector	Line	PE
0.163500	32.90	9.8	55	22.4	AV	L1	GND
0.217500	34.00	9.8	53	18.9	AV	L1	GND
0.384000	22.80	9.8	48	25.4	AV	L1	GND
0.438000	23.80	9.8	47	23.3	AV	L1	GND
0.492000	31.20	9.8	46	14.9	AV	L1	GND
0.793500	5.40	9.8	46	40.6	AV	L1	GND

4.2. Radiated Emission Test

TEST CONFIGURATION

(A) Radiated Emission Test Set-Up, Frequency Below 30MHz

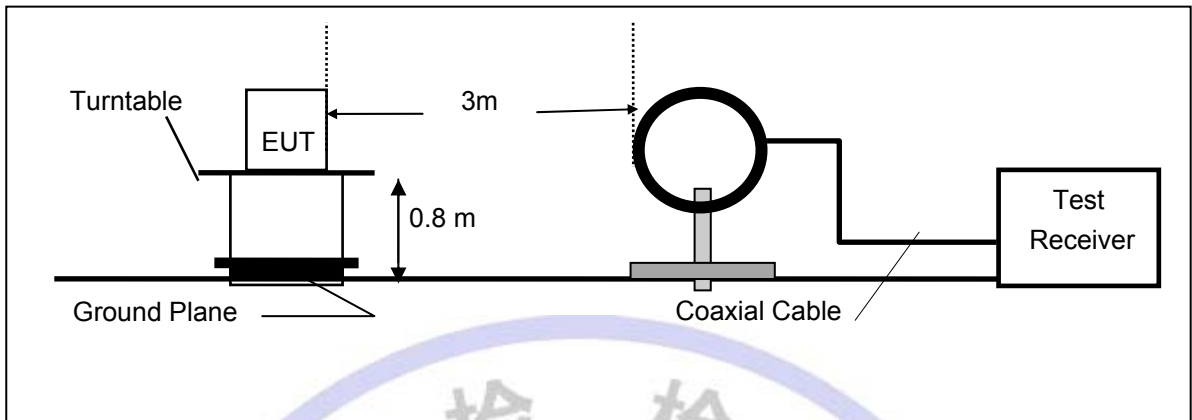

(B) Radiated Emission Test Set-Up, Frequency Below 1000MHz

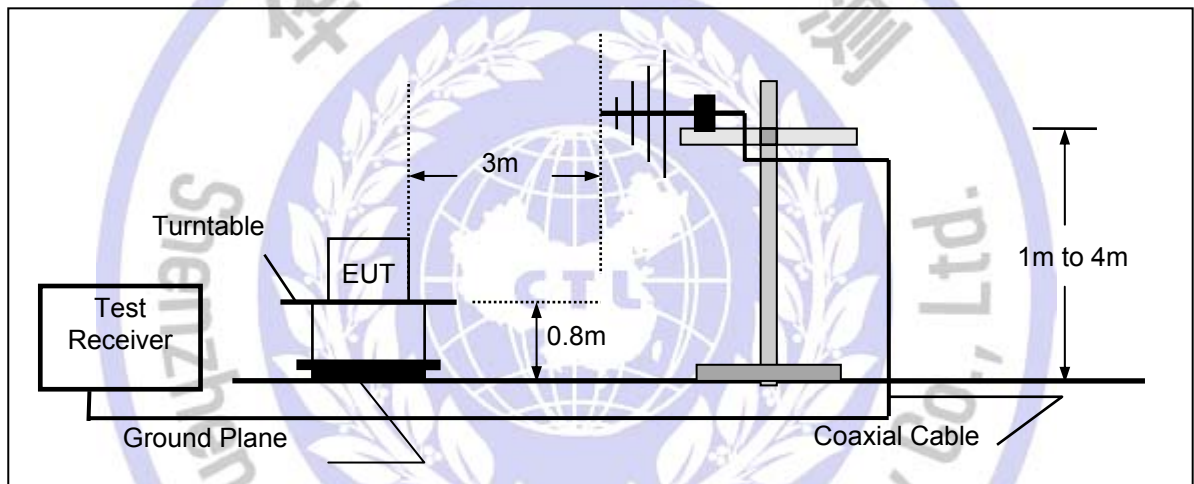

(C) Radiated Emission Test Set-Up, Frequency above 1000MHz

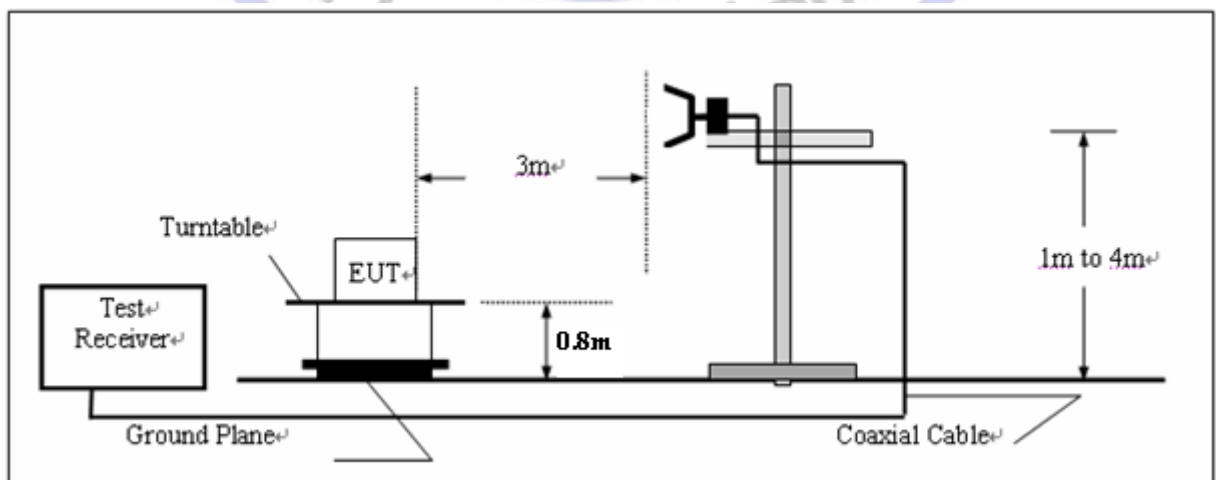

FIELD STRENGTH CALCULATION

The field strength is calculated by adding the Antenna Factor and Cable Factor and subtracting the Amplifier Gain and Duty Cycle Correction Factor(if any) from the measured reading. The basic equation with a sample calculation is as follows:

$$FS = RA + AF + CL - AG$$

Where FS = Field Strength	CL = Cable Attenuation Factor (Cable Loss)
RA = Reading Amplitude	AG = Amplifier Gain
AF = Antenna Factor	

TEST PROCEDURE

1. The testing follows FCC KDB Publication No. 558074 (Measurement Guidelines of DTS), the EUT was setup according to ANSI C63.4: and tested according to ANSI C63.10 for compliance to FCC 47CFR 15.247 requirements.
2. The EUT was placed on a turn table which is 0.8m above ground plane.
3. Maximum procedure was performed by raising the receiving antenna from 1m to 4m and rotating the turn table from 0° to 360° to acquire the highest emissions from EUT
4. And also, each emission was to be maximized by changing the polarization of receiving antenna both horizontal and vertical.
5. Span = wide enough to fully capture the emission being measured; RBW = 1 MHz for f > 1 GHz, 120 kHz for f < 1 GHz; VBW ≥ RBW; Sweep = auto; Detector function = peak; Trace = max hold.
6. Repeat above procedures until all frequency measurements have been completed.

Note:

When doing emission measurement above 1GHz, the horn antenna will be bended down a little (as horn antenna has the narrow beamwidth) in order to keeping the antenna in the “cone of radiation” of EUT. The 3dB beamwidth is 60 degrees for H-plane and 90 degrees for E-plane.

LIMIT

For unintentional device, according to § 15.109(a), except for Class A digital devices, the field strength of radiated emissions from unintentional radiators at a distance of 3 meters shall not exceed the following values:

Frequency (MHz)	Distance (Meters)	Radiated (dBµV/m)	Radiated (µV/m)
30-88	3	40.0	100
88-216	3	43.5	150
216-960	3	46.0	200
Above 960	3	54.0	500

For intentional device, according to § 15.209(a), the general requirement of field strength of radiated emissions from intentional radiators at a distance of 3 meters shall not exceed the above table. According to § 15.247(d), in any 100kHz bandwidth outside the frequency band in which the EUT is operating, the radio frequency power that is produced by the intentional radiator shall be at least 20dB below that in the 100kHz bandwidth within the band that contains the highest level of desired power.

TEST RESULTS

802.11b

CH	Antenna	Frequency (MHz)	Reading Level (dBuV/m)	Factor (dB)	Measure Level (dBuV/m)	Limit (dBuV/m)	Margin (dB)	Detector
1	V	2412.0	74.7	30.8	105.5	Fundamental	/	PK
	V	322.5	15.9	14.8	30.7	46	-15.3	QP
	V	510.0	15.0	19.7	34.7	46	-11.3	QP
	V	3200.0	43.8	-0.6	43.2	54(note3)	-10.8	PK
	V	4825.0	47.5	2.6	50.1	54(note3)	-3.9	PK
	V	7239.0	51.2	8.1	59.3	74	-13.9	PK
	V	7236.0	44.2	8.5	52.7	54	-1.3	AV
	H	24000.0	59.1	-8.9	50.2	54(note3)	-3.8	PK
6	V	2437.0	71.3	31.2	102.5	Fundamental	/	PK
	V	327.1	13.3	15.2	28.5	46	-17.5	QP
	V	573.6	13.1	21.2	34.3	46	-11.7	QP
	V	3200.0	43.2	-0.6	42.6	54(note3)	-11.4	PK
	V	4876.0	49.2	2.8	52.0	54(note3)	-2.0	PK
	V	7315.5	53.3	8.8	62.1	74	-11.9	PK
	V	7311.0	43.9	8.8	52.7	54	-1.3	AV
	H	24000.0	59.1	-8.9	50.2	54(note3)	-3.8	PK
11	V	2462.0	70.3	30.9	101.2	Fundamental	/	PK
	V	326.3	12.6	14.9	27.5	46	-18.5	QP
	H	582.0	12.9	21.2	34.1	46	-11.9	QP
	V	3200.0	44.1	-0.6	43.5	54(note3)	-10.5	PK
	V	4927.0	45.1	3.0	48.1	54(note3)	-5.9	PK
	V	7383.5	50.8	8.9	59.7	74	-14.3	PK
	V	7386.0	43.4	8.9	52.3	54	-1.7	AV
	H	24000.0	59.1	-8.9	50.2	54(note3)	-3.8	PK

Note: 1. Measure Level = Reading Level + Factor.

2. The test trace is same as the ambient noise and the test results which are attenuated more than 20 dB below the permissible value limit (the test frequency range: 9kHz~30MHz, 18GHz~25GHz), therefore no data appear in the report.

3. This limit applies for using average detector, if the test result on peak is lower than average limit, then average measurement needn't be performed.

802.11g

CH	Antenna	Frequency (MHz)	Reading Level (dBuV/m)	Factor (dB)	Measure Level (dBuV/m)	Limit (dBuV/m)	Margin (dB)	Detector
1	V	2411.9	69.3	31.9	101.2	Fundamental	/	PK
	H	255.8	13.4	15.7	29.1	46	-17.9	QP
	H	523.4	13.9	21.3	35.2	46	-10.8	QP
	V	3200	50.0	-13.4	36.6	54(note3)	-17.4	PK
	V	4824.0	43.3	2.6	45.9	54(note3)	-8.1	PK
	V	7236.0	36.7	8.9	45.6	54	-8.4	AV
	V	7239.0	50.2	8.9	59.1	74	-14.9	PK
	H	24000.0	59.1	-8.9	50.2	54(note3)	-3.8	PK
6	V	2437.0	70.1	31.2	101.3	Fundamental	/	PK
	V	332.6	12.7	14.8	27.5	46	-18.5	QP
	V	595.9	13.8	21.2	35.0	46	-11.0	QP
	V	3200.0	42.5	-0.6	41.9	54(note3)	-12.1	PK
	V	4876.0	45.6	2.8	48.4	54(note3)	-5.6	PK
	V	7298.5	44.2	8.8	53.0	54(note3)	-1.0	PK
	H	24000.0	59.1	-8.9	50.2	54(note3)	-3.8	PK
11	V	2462.3	70.6	30.9	101.5	Fundamental	/	PK
	H	582.7	13.7	21.2	34.9	46	-11.1	QP
	V	281.2	12.5	14.7	27.2	46	-18.8	QP
	V	3200.0	42.7	-0.6	42.1	54(note3)	-11.9	PK
	V	4927.0	45.9	3.0	48.9	54(note3)	-5.1	PK
	V	7386.0	37.4	8.9	46.3	54	-7.7	AV
	V	7392.0	51.8	8.9	60.7	74	-13.3	PK
H	24000.0	59.1	-8.9	50.2	54(note3)	-3.8	PK	

Note: 1. Measure Level = Reading Level + Factor.

2. The test trace is same as the ambient noise and the test results which are attenuated more than 20 dB below the permissible value limit (the test frequency range: 9kHz~30MHz, 18GHz~25GHz), therefore no data appear in the report.

3. This limit applies for using average detector, if the test result on peak is lower than average limit, then average measurement needn't be performed.

802.11n(20MHz)

CH	Antenna	Frequency (MHz)	Reading Level (dBuV/m)	Factor (dB)	Measure Level (dBuV/m)	Limit (dBuV/m)	Margin (dB)	Detector
1	V	2412.1	69.5	30.7	100.5	Fundamental	/	PK
	H	592.2	14.1	21.2	35.3	46	-10.7	QP
	H	312.2	12.5	15.1	27.6	46	-18.4	QP
	V	3200.0	42.4	-0.6	41.8	54(note3)	-12.2	PK
	V	4824.0	42.3	2.6	44.9	54(note3)	-9.1	PK
	V	7236.0	33.6	8.9	42.5	54	-11.5	AV
	V	7239.0	46.2	8.9	55.1	74	-18.9	PK
	H	24000.0	59.1	-8.9	50.2	54(note3)	-3.8	PK
6	V	2437.0	69.3	31.2	100.5	Fundamental	/	PK
	H	563.3	13.8	21.2	35.0	46	-11.0	QP
	H	342.6	13.2	16.0	29.2	46	-16.8	QP
	V	3200.0	42.5	-0.6	41.9	54(note3)	-12.1	PK
	V	4876.0	45.5	2.8	48.3	54(note3)	-5.7	PK
	V	7307.0	54.6	8.8	63.4	74	-10.6	PK
	V	7310.6	41.0	8.8	49.8	54	-4.2	AV
	H	24000.0	59.1	-8.9	50.2	54(note3)	-3.8	PK
11	V	2462.0	70.3	30.9	101.2	Fundamental	/	PK
	H	302.4	13.7	14.7	28.4	46	-17.6	QP
	H	551.2	13.5	21.2	34.7	46	-11.3	QP
	V	3200.0	43.2	-0.6	42.6	54(note3)	-11.4	PK
	V	4924.0	42.7	3.0	45.7	54(note3)	-8.3	PK
	V	7375.0	50.1	9.0	59.0	74	-15.0	PK
	V	7378.3	34.0	9.0	42.9	54	-11.1	AV
	H	24000.0	59.1	-8.9	50.2	54(note3)	-3.8	PK

Note: 1. Measure Level = Reading Level + Factor.

2. The test trace is same as the ambient noise and the test results which are attenuated more than 20 dB below the permissible value limit (the test frequency range: 9kHz~30MHz, 18GHz~25GHz), therefore no data appear in the report.

3. This limit applies for using average detector, if the test result on peak is lower than average limit, then average measurement needn't be performed.

802.11n(40MHz)

CH	Antenna	Frequency (MHz)	Reading Level (dBuV/m)	Factor (dB)	Measure Level (dBuV/m)	Limit (dBuV/m)	Margin (dB)	Detector
3	V	2423.6	65.4	31.8	97.2	Fundamental	/	PK
	H	345.2	14.2	16.0	30.2	46	-15.8	QP
	H	561.0	14.4	21.2	35.6	46	-10.3	QP
	V	3200.0	42.5	-0.6	41.9	54(note3)	-12.1	PK
	V	4844.0	41.5	2.6	44.2	54(note3)	-9.8	PK
	V	7290.0	44.5	8.8	53.3	54(note3)	-0.7	PK
	H	24000.0	59.1	-8.9	50.2	54(note3)	-3.8	PK
6	V	2437.0	64.7	31.2	95.9	Fundamental	/	PK
	H	293.2	12.9	14.8	27.7	46	-18.3	QP
	H	556.3	13.2	21.2	34.4	46	-11.2	QP
	V	3200.0	42.1	-0.6	41.5	54(note3)	-12.5	PK
	V	4874.0	41.6	2.8	44.4	54(note3)	-9.6	PK
	V	7349.2	32.0	9.0	40.9	54	-13.1	AV
	V	7358.0	46.6	9.0	55.6	74	-18.4	PK
9	H	24000.0	59.1	-8.9	50.2	54(note3)	-3.8	PK
	V	2453.6	64.7	30.9	95.6	Fundamental	/	PK
	H	582.7	14.5	21.2	35.7	46	-10.7	QP
	H	298.4	13.2	14.8	28.0	46	-17.8	QP
	V	3200.0	42.6	-0.6	42.0	54(note3)	-12.0	PK
	V	4904.0	41.9	2.9	44.8	54(note3)	-9.2	PK
	V	7349.4	32.2	9.0	41.2	54	-12.8	AV
V	7349.5	45.6	9.0	54.5	74	-19.5	PK	
H	24000.0	59.1	-8.9	50.2	54(note3)	-3.8	PK	

Note: 1. Measure Level = Reading Level + Factor.

2. The test trace is same as the ambient noise and the test results which are attenuated more than 20 dB below the permissible value limit (the test frequency range: 9kHz~30MHz, 18GHz~25GHz), therefore no data appear in the report.

3. This limit applies for using average detector, if the test result on peak is lower than average limit, then average measurement needn't be performed.

The worst case of Radiated Emission below 1GHz:

SWEEP TABLE: "test (30M-1G)"

Short Description:		Field Strength			
Start	Stop	Detector	Meas. Time	IF Bandw.	Transducer
Frequency 30.0 MHz	Frequency 1.0 GHz	MaxPeak	300.0 ms	120 kHz	JB1

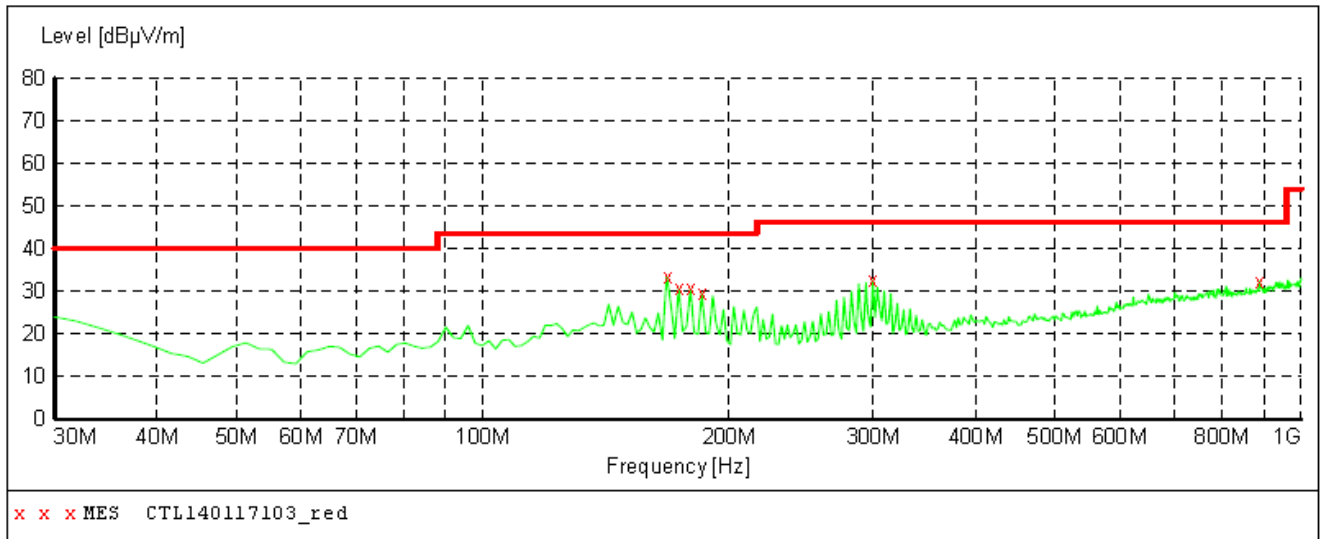

MEASUREMENT RESULT: "CTL140117103_red"

1/17/2014 8:51AM

Frequency MHz	Level dBµV/m	Transd dB	Limit dBµV/m	Margin dB	Det.	Height cm	Azimuth deg	Polarization
167.740000	33.40	13.7	43.5	10.1	---	0.0	0.00	HORIZONTAL
173.560000	30.60	13.3	43.5	12.9	---	0.0	0.00	HORIZONTAL
179.380000	30.60	13.3	43.5	12.9	---	0.0	0.00	HORIZONTAL
185.200000	29.60	13.4	43.5	13.9	---	0.0	0.00	HORIZONTAL
299.660000	32.60	15.4	46.0	13.4	---	0.0	0.00	HORIZONTAL
889.420000	32.30	25.9	46.0	13.7	---	0.0	0.00	HORIZONTAL



SWEEP TABLE: "test (30M-1G)"

Short Description:		Field Strength			
Start	Stop	Detector	Meas. Time	IF Bandw.	Transducer
Frequency	Frequency				
30.0 MHz	1.0 GHz	MaxPeak	300.0 ms	120 kHz	JB1

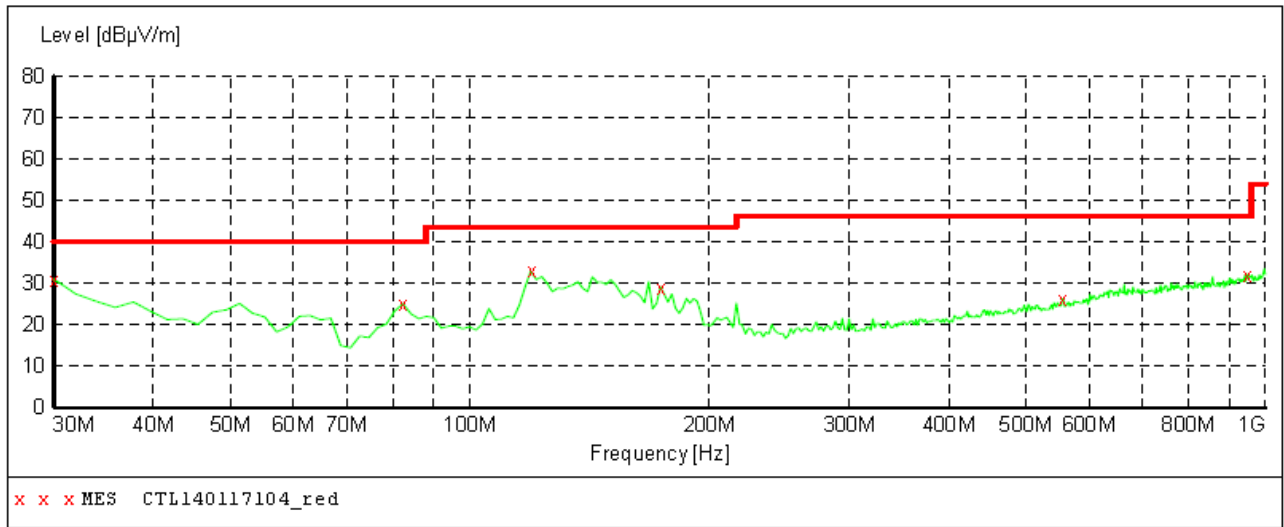

MEASUREMENT RESULT: "CTL140117104_red"

1/17/2014 8:53AM

Frequency MHz	Level dBµV/m	Transd dB	Limit dBµV/m	Margin dB	Det.	Height cm	Azimuth deg	Polarization
30.000000	30.90	21.1	40.0	9.1	---	0.0	0.00	VERTICAL
82.380000	25.00	9.0	40.0	15.0	---	0.0	0.00	VERTICAL
119.240000	32.90	15.2	43.5	10.6	---	0.0	0.00	VERTICAL
173.560000	29.00	13.3	43.5	14.5	---	0.0	0.00	VERTICAL
555.740000	26.20	21.1	46.0	19.8	---	0.0	0.00	VERTICAL
947.620000	32.10	26.6	46.0	13.9	---	0.0	0.00	VERTICAL



4.3. 6dB and 99% Bandwidth Measurement

TEST CONFIGURATION

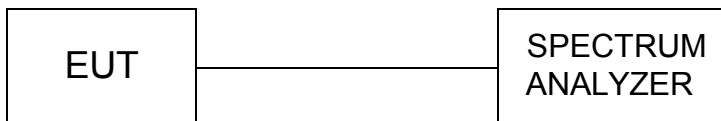

TEST PROCEDURE

1. The testing follows FCC KDB Publication No. 558074 (Measurement Guidelines of DTS).
2. The RF output of EUT was connected to the spectrum analyzer by a low loss cable.
3. Make the measurement with the spectrum analyzer's resolution bandwidth (RBW) = 100 kHz. In order to make an accurate measurement, set the span greater than RBW. The 6 dB bandwidth must be greater than 500 kHz.
4. The marker-delta reading at this point is the 6 dB bandwidth of the emission.

LIMIT

For digital modulation systems, the minimum 6 dB bandwidth shall be at least 500 kHz.

TEST RESULTS

Product	:	HS-7DTB26-4GB
Test Item	:	6dB Occupied Bandwidth
Test Mode	:	Mode 1: Transmit by 802.11b

Channel No.	Frequency (MHz)	Occupied Bandwidth 6dB/99% (kHz)	Limit (kHz)	Result
01	2412	9100/15100	500	Pass
06	2437	9200/15100	500	Pass
11	2462	9300/15000	500	Pass

Channel 01 (2412MHz)



*RBW 100 kHz Delta 3 [T1]
VBW 300 kHz -6.32 dB
SWT 5 ms 5.000000000 MHz

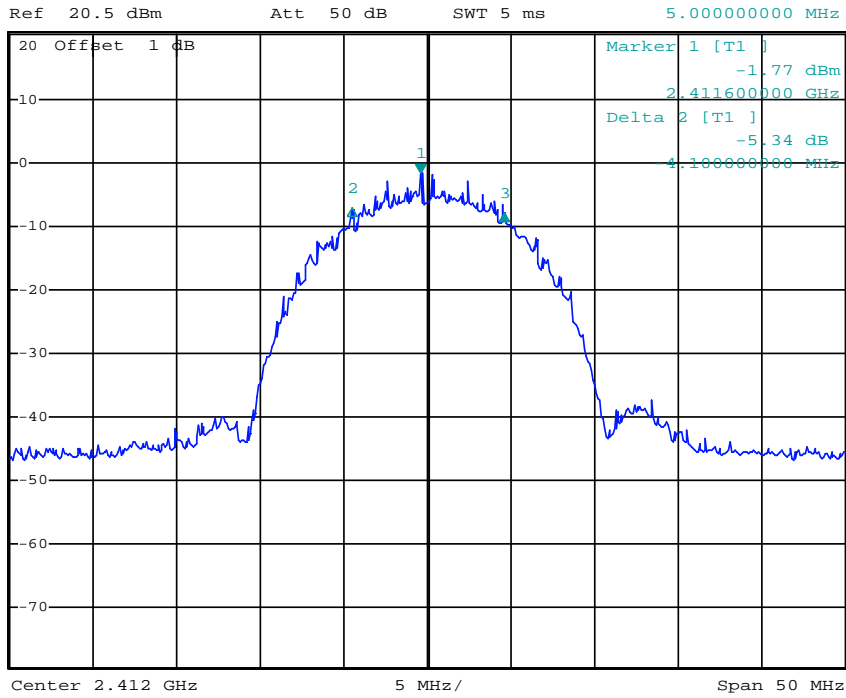

Date: 17.JAN.2014 15:19:43



*RBW 100 kHz Marker 1 [T1]
*VBW 300 kHz 5.46 dBm
SWT 5 ms 2.412300000 GHz

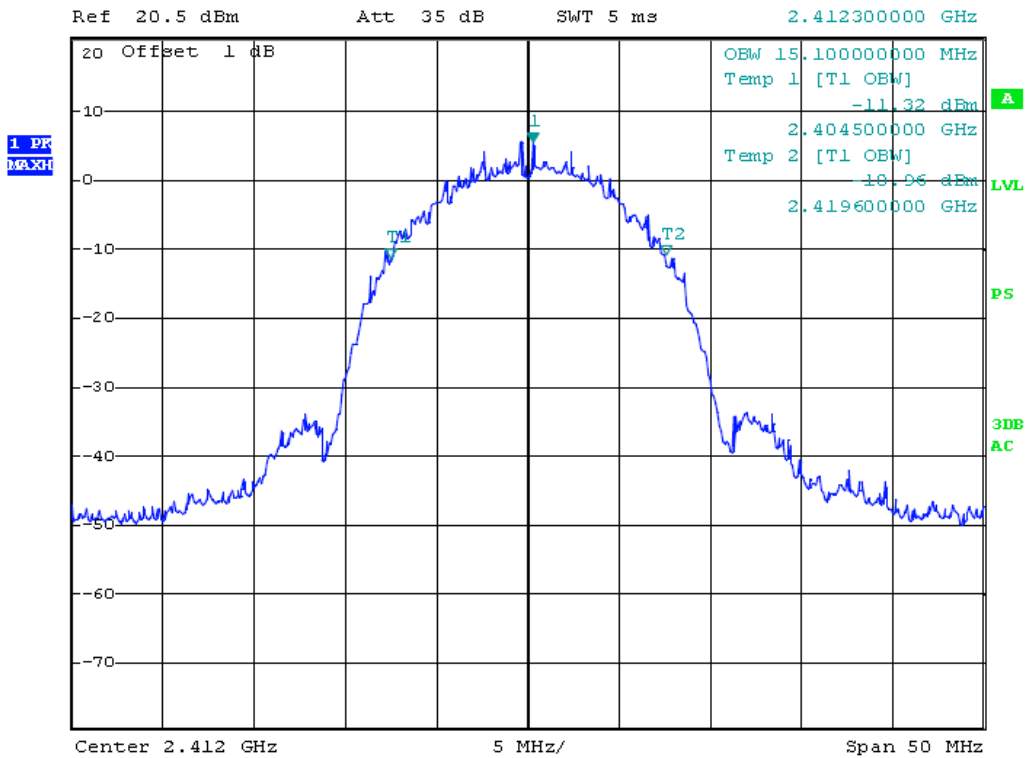

Channel 06 (2437MHz)



*RBW 100 kHz Delta 3 [T1]
VBW 300 kHz -6.55 dB
Ref 20.5 dBm Att 50 dB SWT 5 ms 4.400000000 MHz

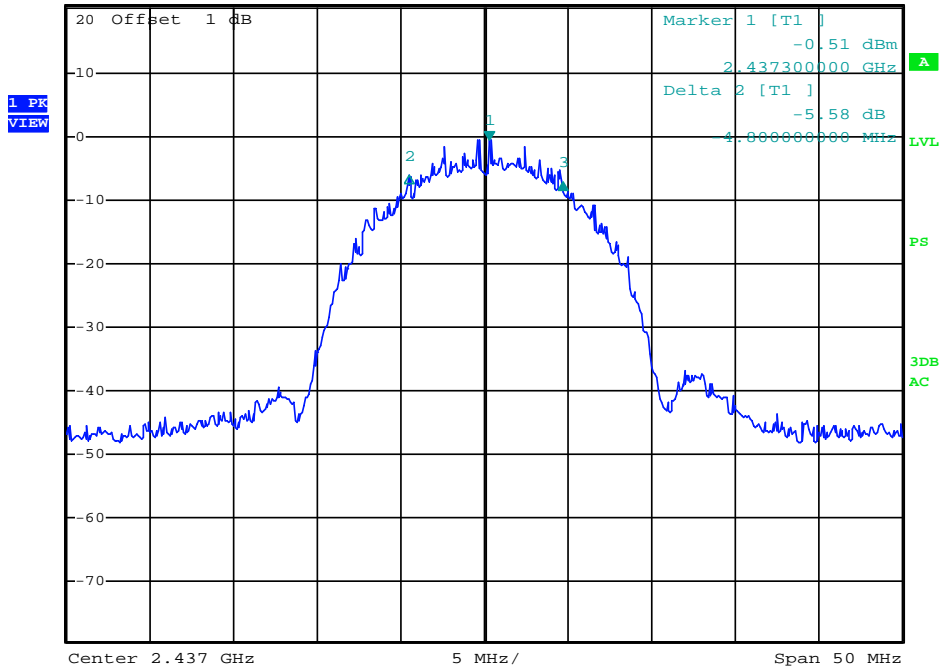

Date: 17.JAN.2014 15:18:46



*RBW 100 kHz Marker 1 [T1]
*VBW 300 kHz -5.61 dBm
Ref 20.5 dBm Att 35 dB SWT 500 ms 2.436400000 GHz

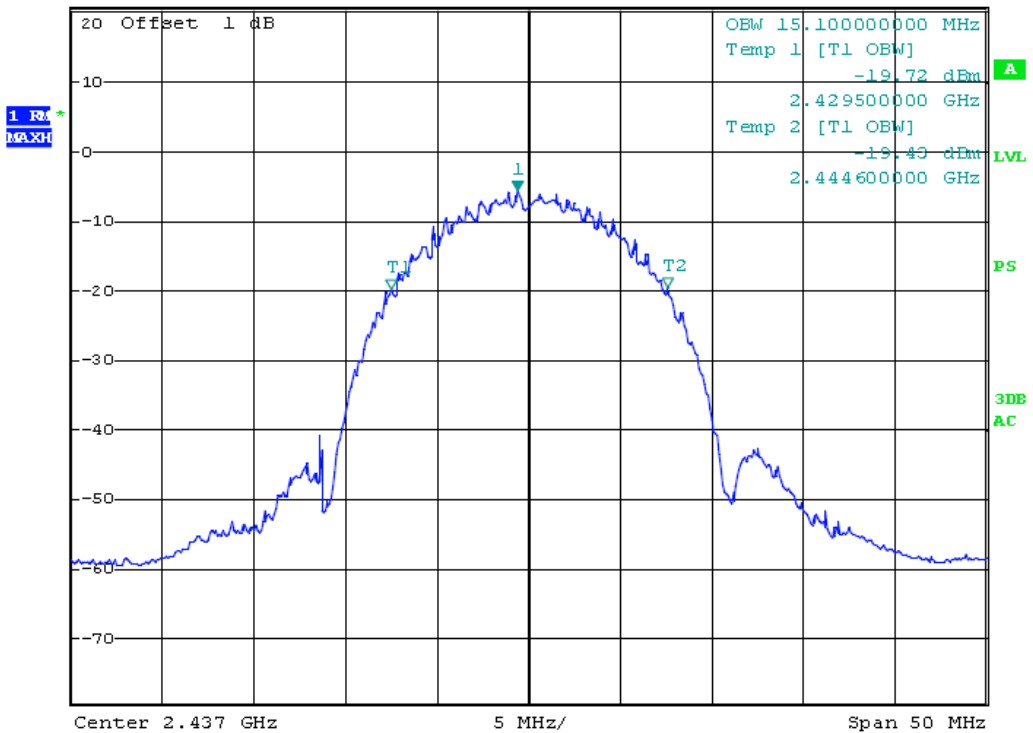

Channel 11 (2462MHz)

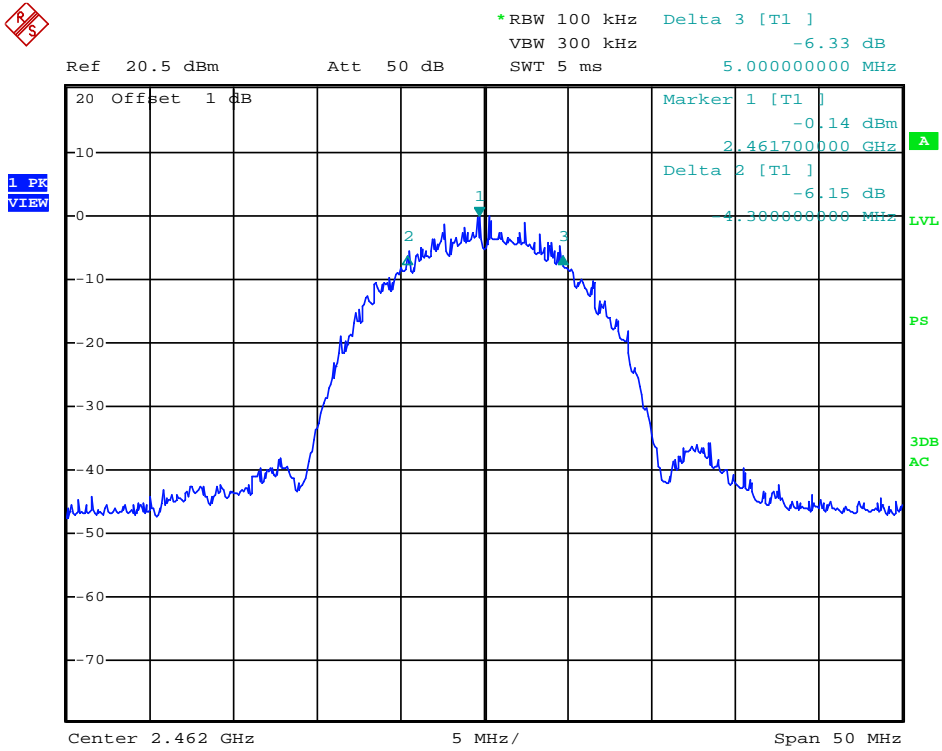

Date: 17.JAN.2014 15:17:52

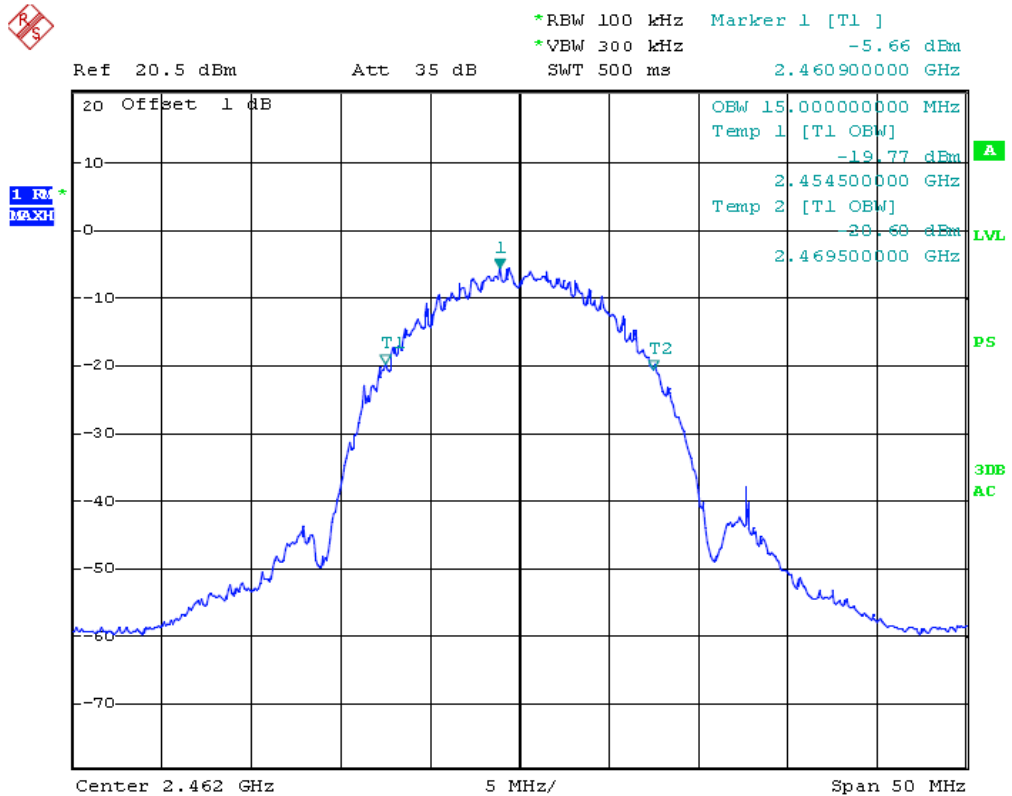

Product	:	HS-7DTB26-4GB
Test Item	:	6dB Occupied Bandwidth
Test Mode	:	Mode 2: Transmit by 802.11g

Channel No.	Frequency (MHz)	Occupied Bandwidth 6dB/99% (kHz)	Limit (kHz)	Result
01	2412	16600/16400	500	Pass
06	2437	16600/16400	500	Pass
11	2462	16600/16400	500	Pass

Channel 01 (2412MHz)

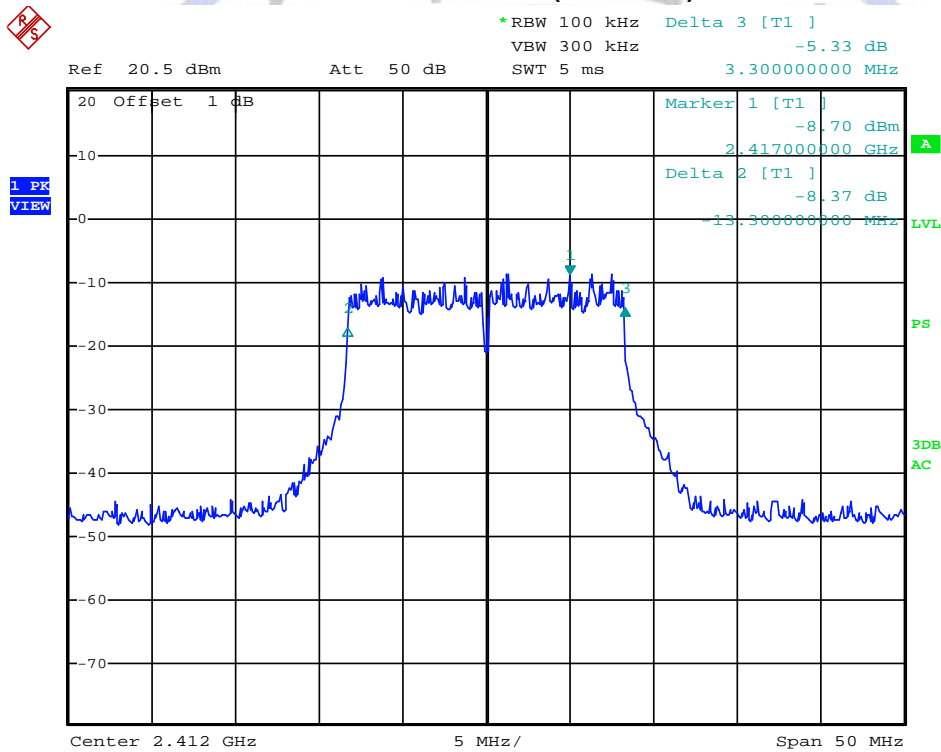

Date: 17.JAN.2014 15:21:29



*RBW 100 kHz Marker 1 [T1]
*VBW 300 kHz -13.93 dBm
SWT 500 ms 2.404500000 GHz

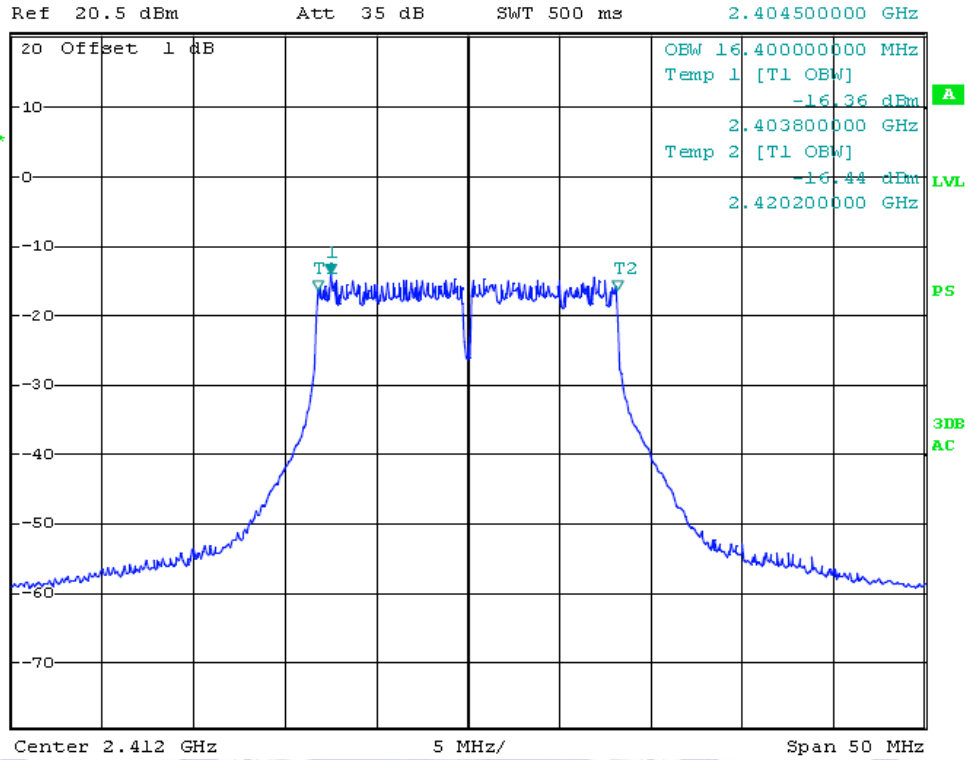

Channel 06 (2437MHz)

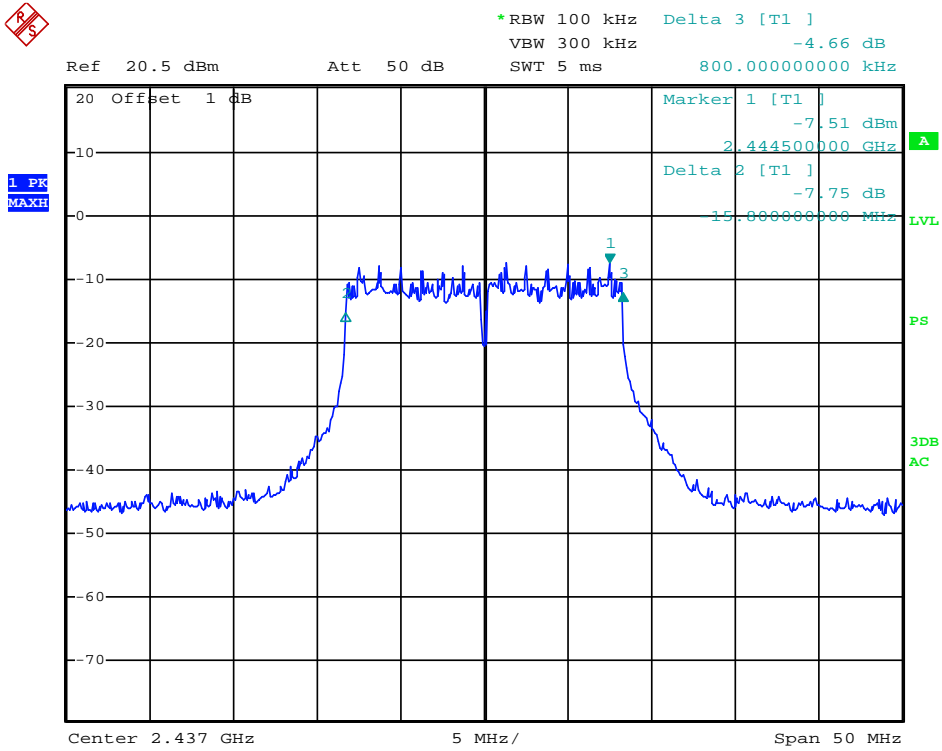

Date: 17.JAN.2014 15:22:14

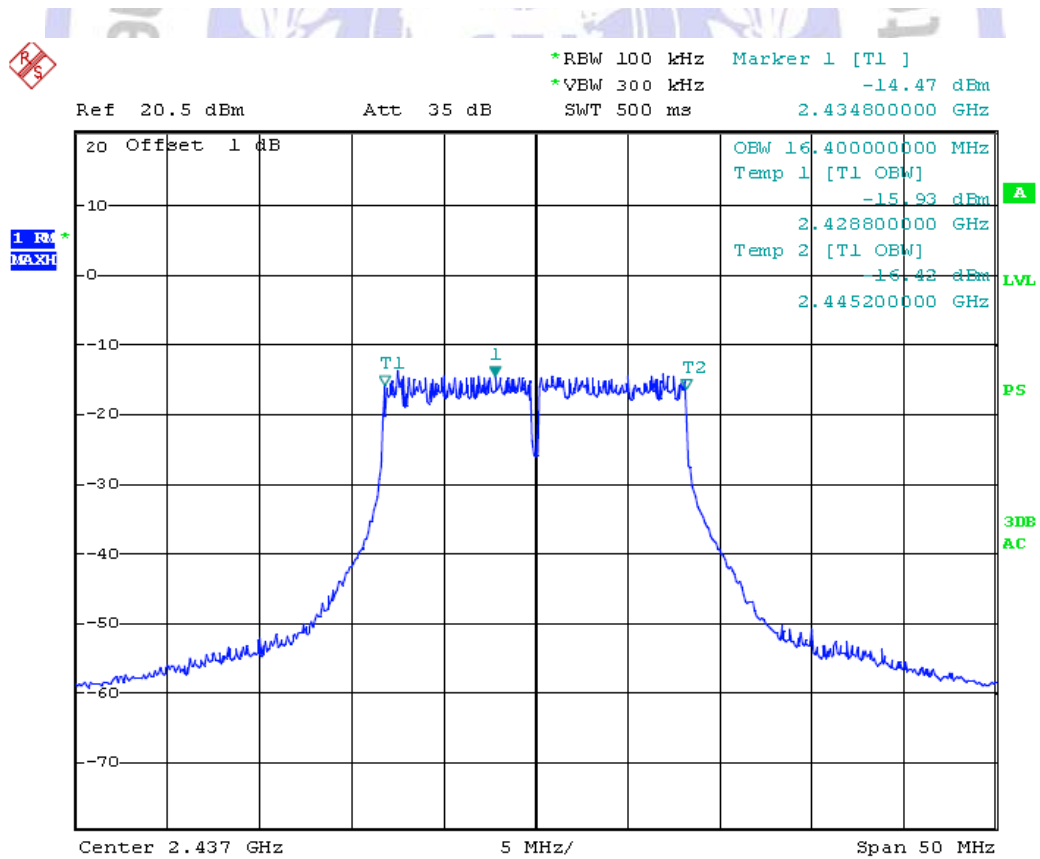

Channel 11 (2462MHz)

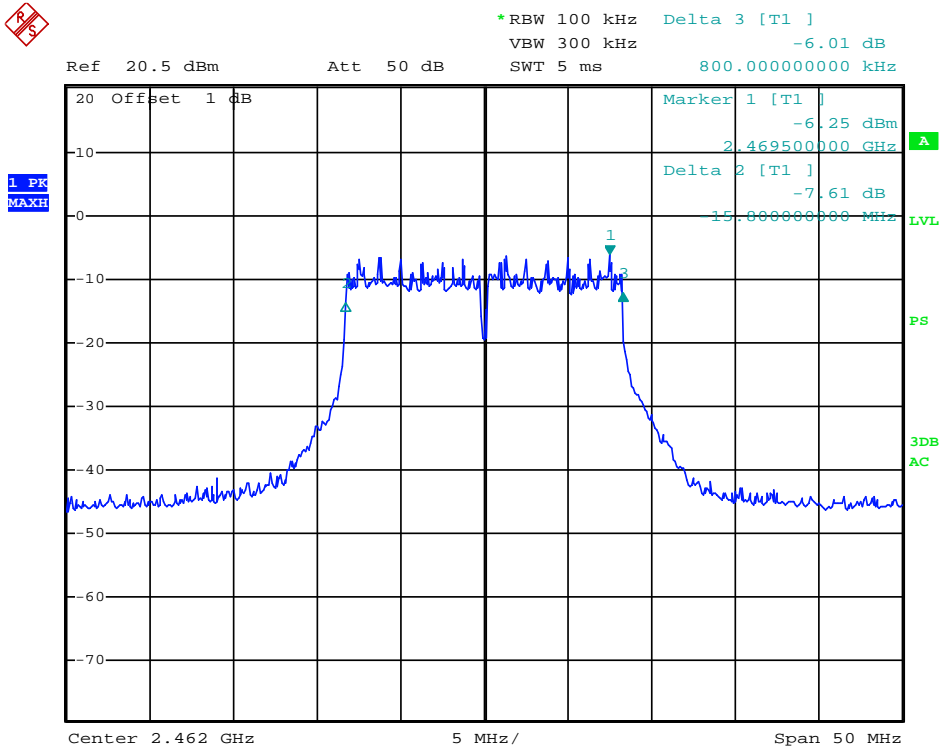

Date: 17.JAN.2014 15:23:10

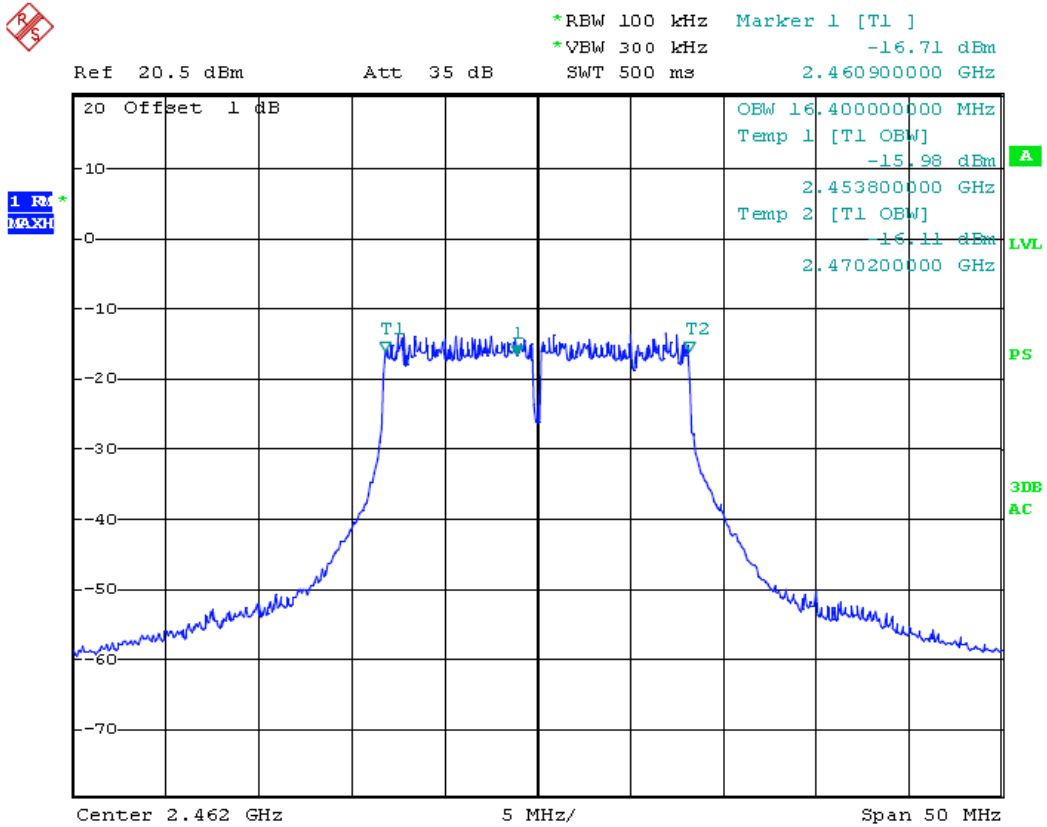

Product	:	HS-7DTB26-4GB
Test Item	:	6dB Occupied Bandwidth
Test Mode	:	Mode 3: Transmit by 802.11n (20MHz)

Channel No.	Frequency (MHz)	Occupied Bandwidth 6dB/99% (kHz)	Limit (kHz)	Result
01	2412	17700/17700	500	Pass
06	2437	17700/17700	500	Pass
11	2462	17800/17800	500	Pass

Channel 01 (2412MHz)

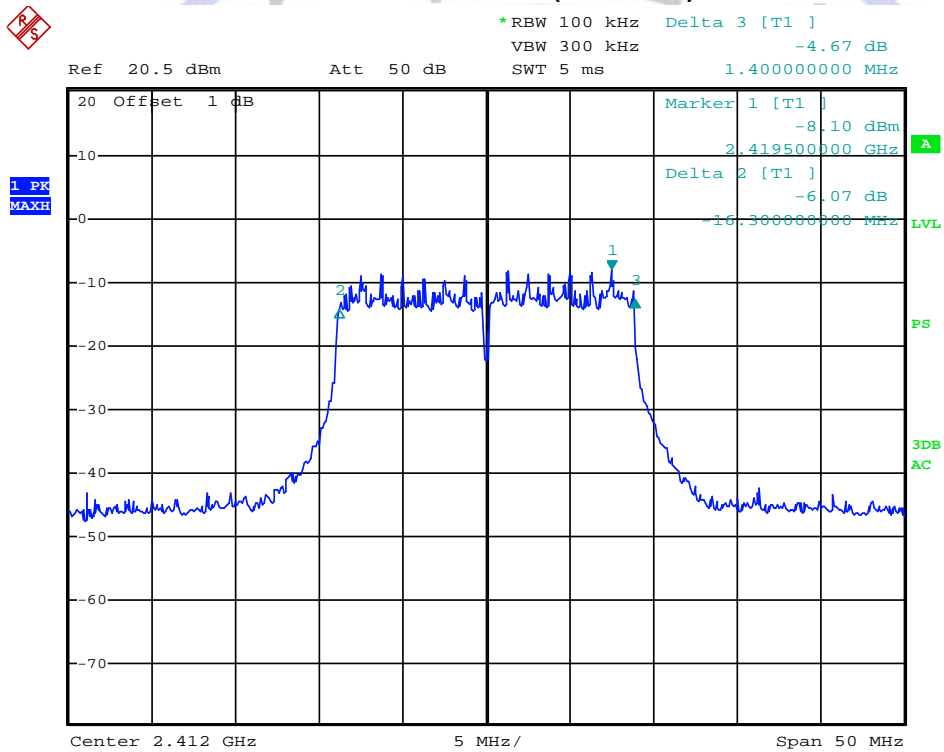

Date: 17.JAN.2014 15:25:23



*RBW 100 kHz Marker 1 [T1]
*VBW 300 kHz -14.53 dBm
SWT 500 ms 2.418300000 GHz

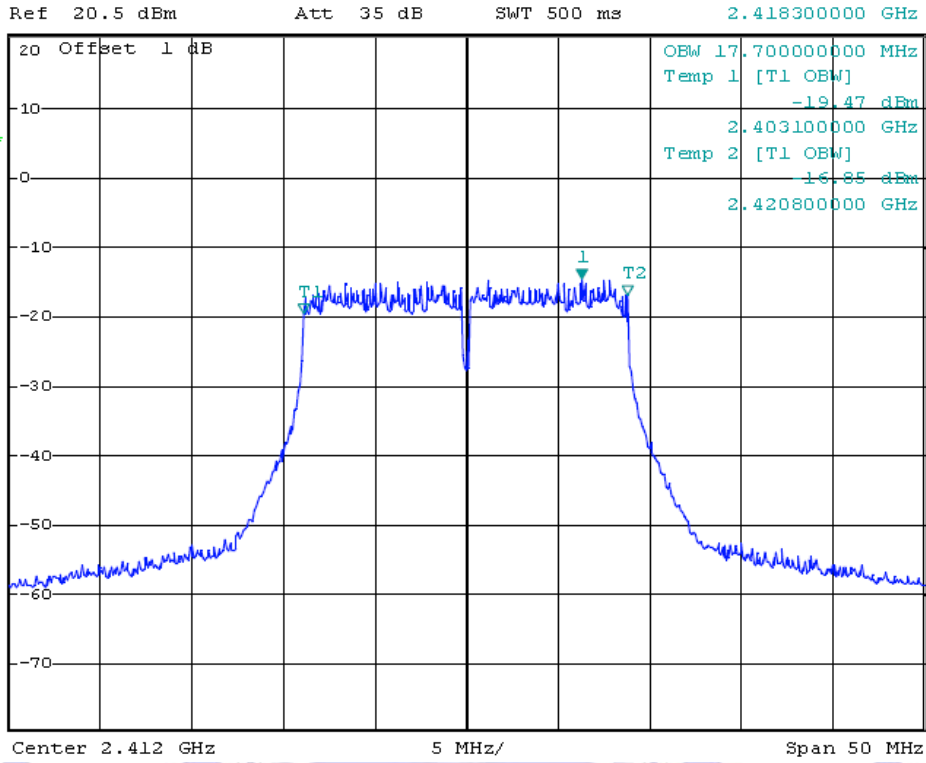

Channel 06 (2437MHz)

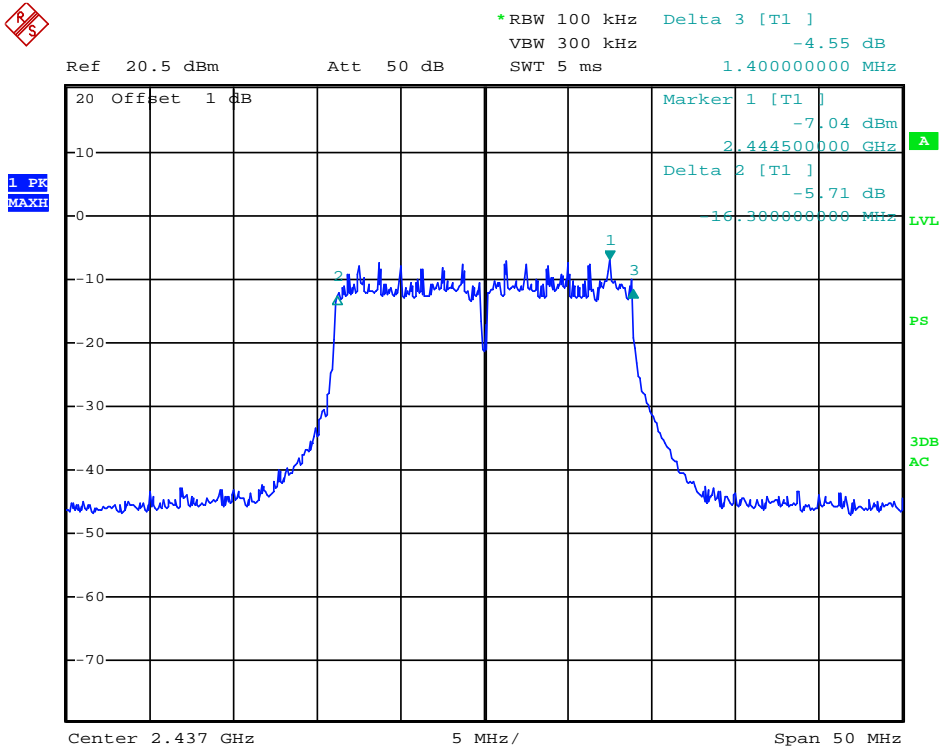

Date: 17.JAN.2014 15:24:43

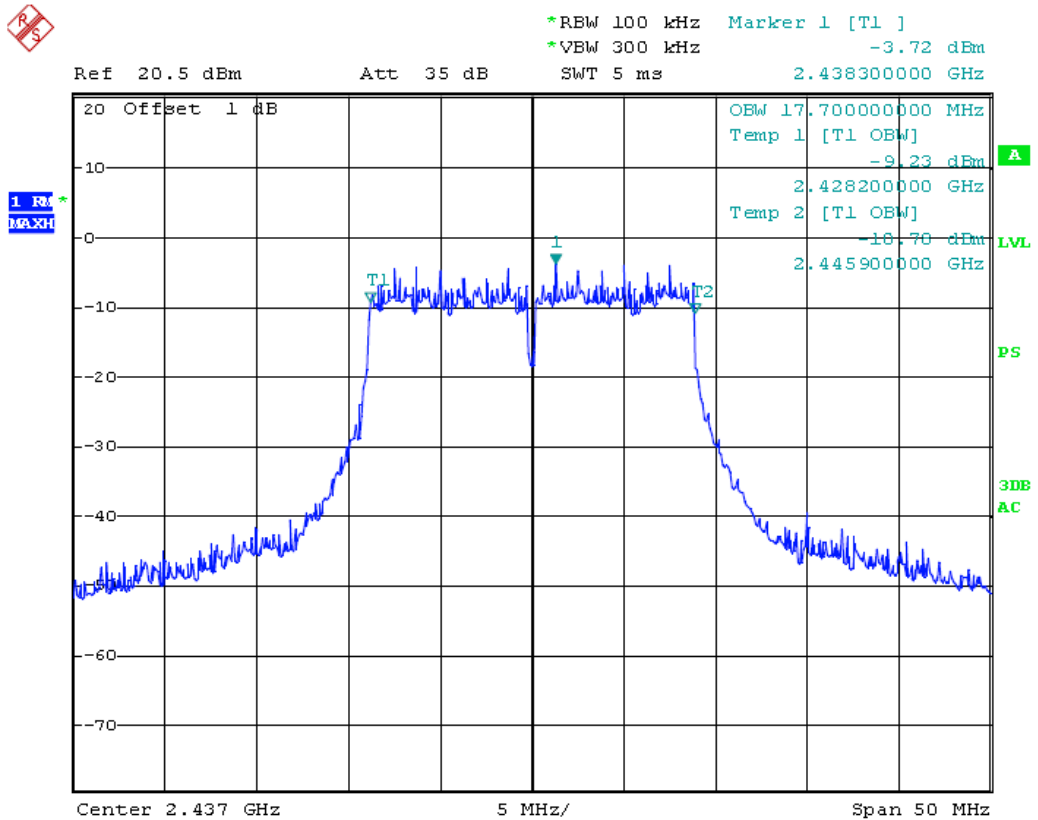

Channel 11 (2462MHz)

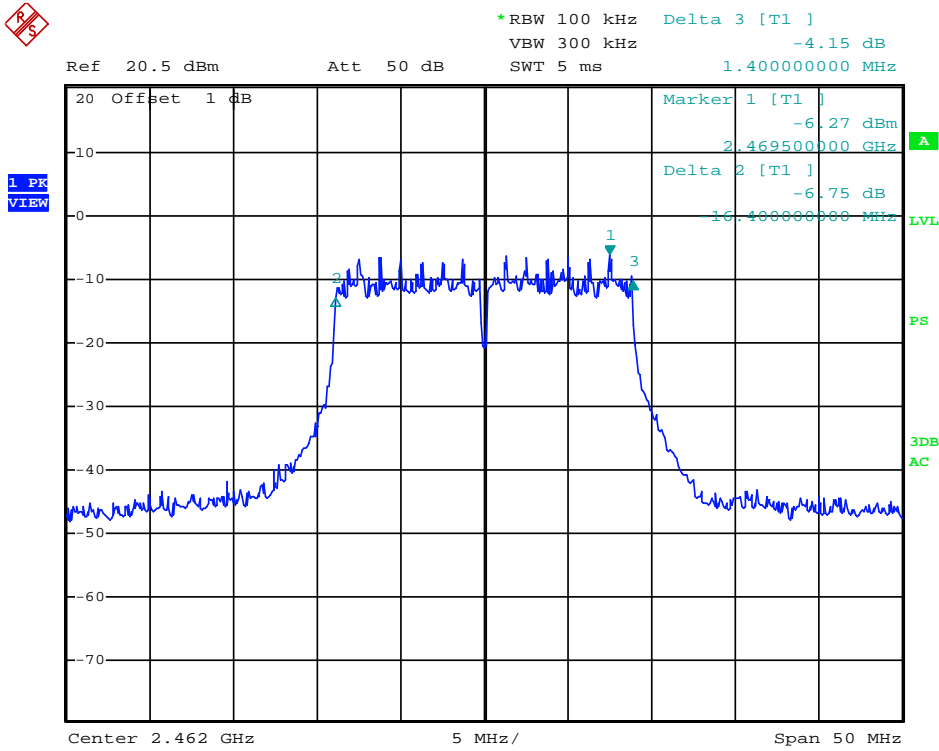

Date: 17.JAN.2014 15:23:55

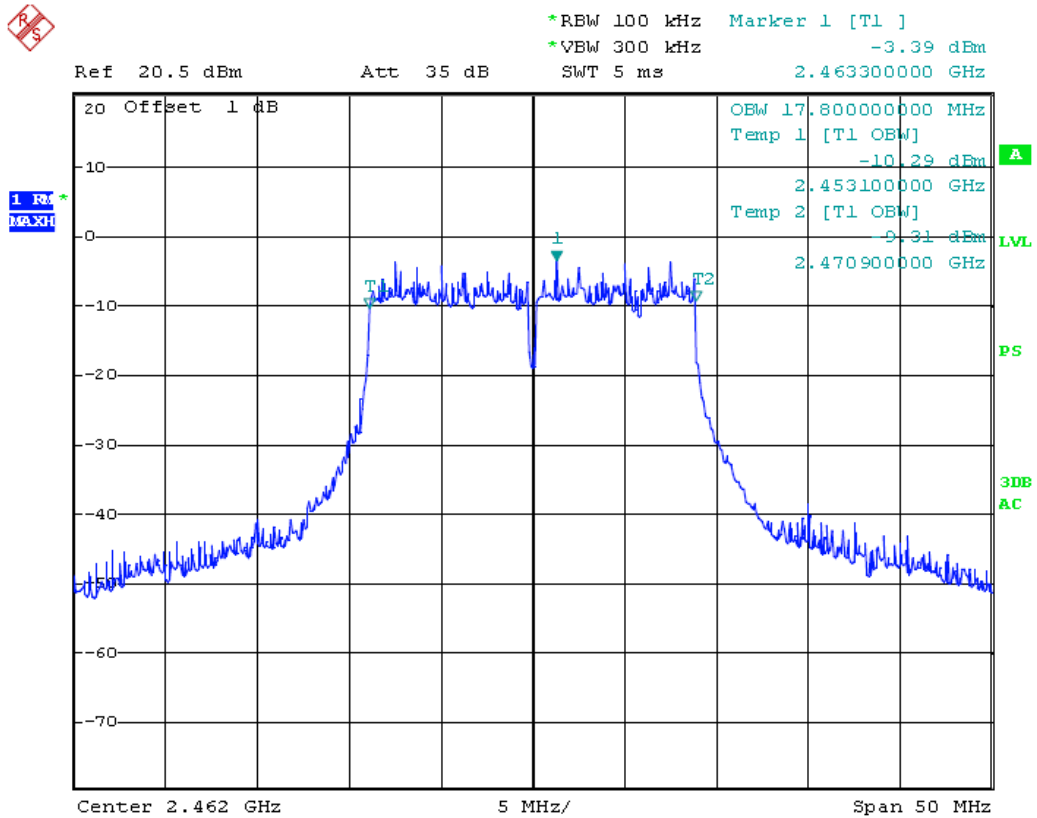

Product	:	HS-7DTB26-4GB
Test Item	:	6dB Occupied Bandwidth
Test Mode	:	Mode 4: Transmit by 802.11n (40MHz)

Channel No.	Frequency (MHz)	Occupied Bandwidth 6dB/99% (kHz)	Limit (kHz)	Result
03	2422	36100/36200	500	Pass
06	2437	36000/36000	500	Pass
09	2452	36000/36000	500	Pass

Channel 03 (2422MHz)

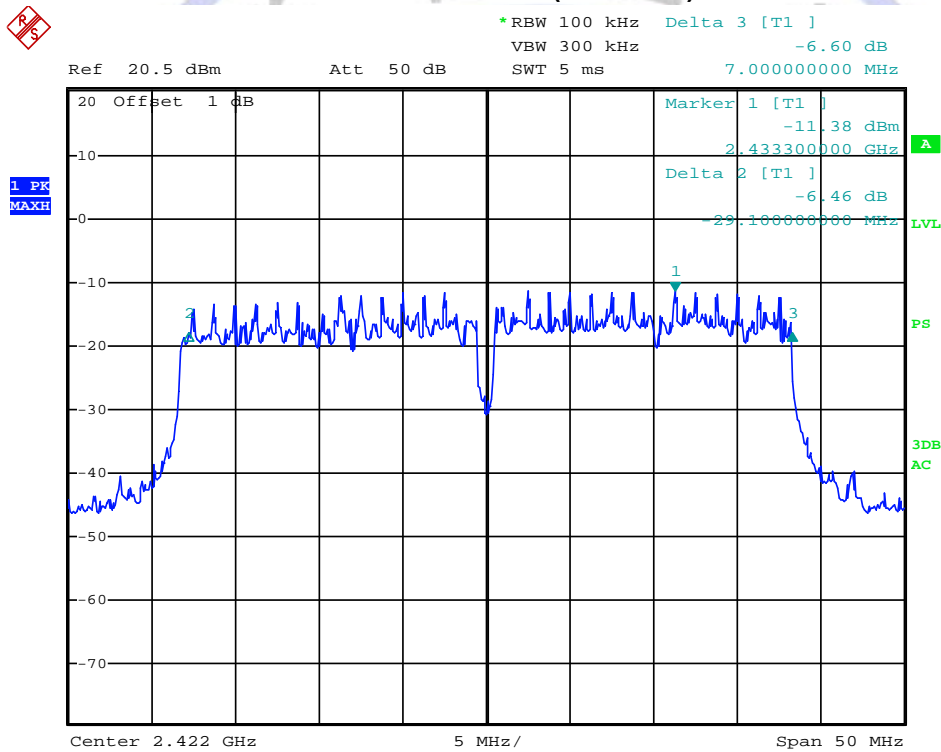

Date: 17.JAN.2014 15:26:46



*RBW 100 kHz Marker 1 [T1]
*VBW 300 kHz -8.83 dBm
SWT 10 ms 2.417000000 GHz

Ref 20.5 dBm Att 35 dB

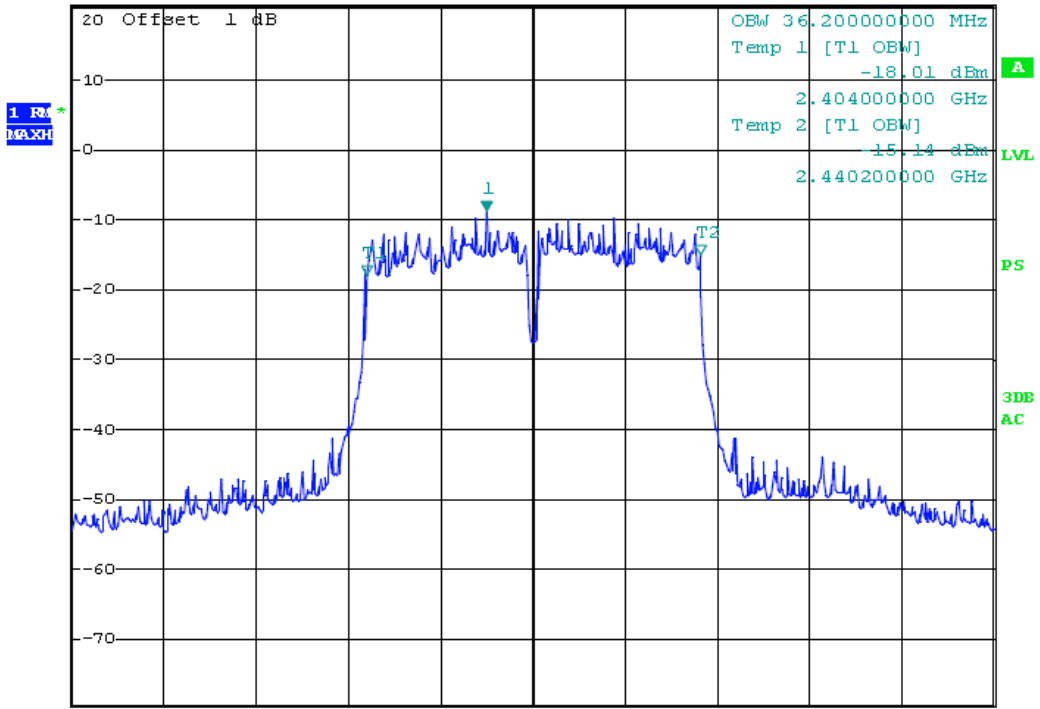

Center 2.422 GHz 10 MHz/ Span 100 MHz



Channel 06 (2437MHz)

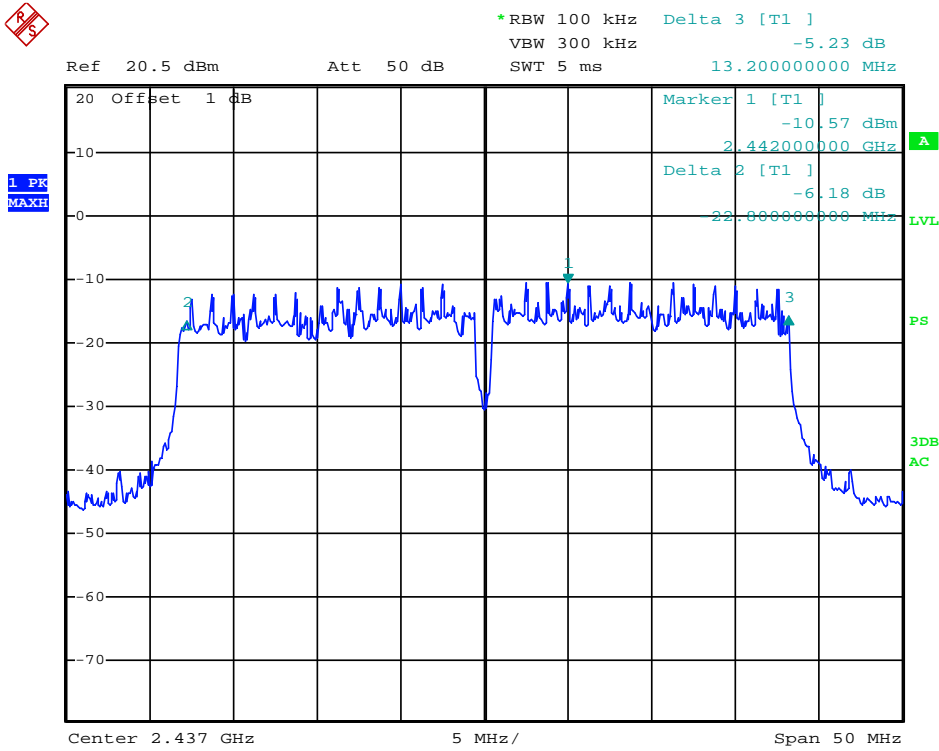

Date: 17.JAN.2014 15:27:52

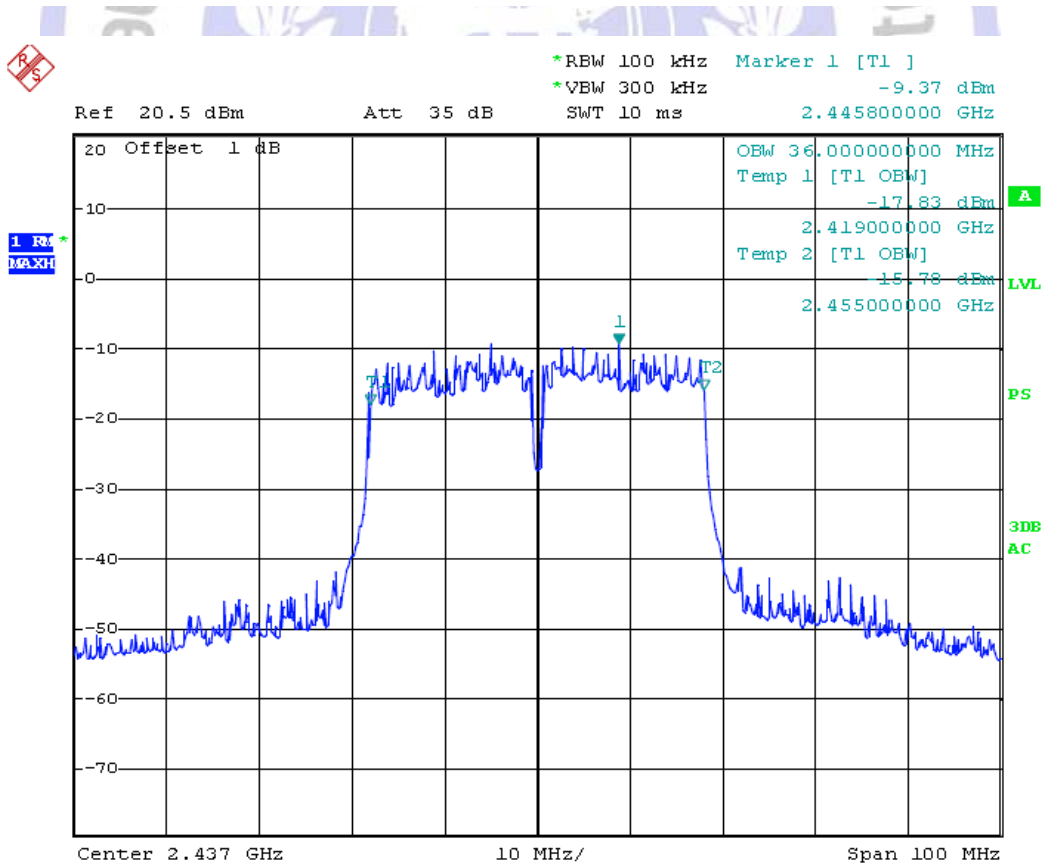

Channel 09 (2452MHz)

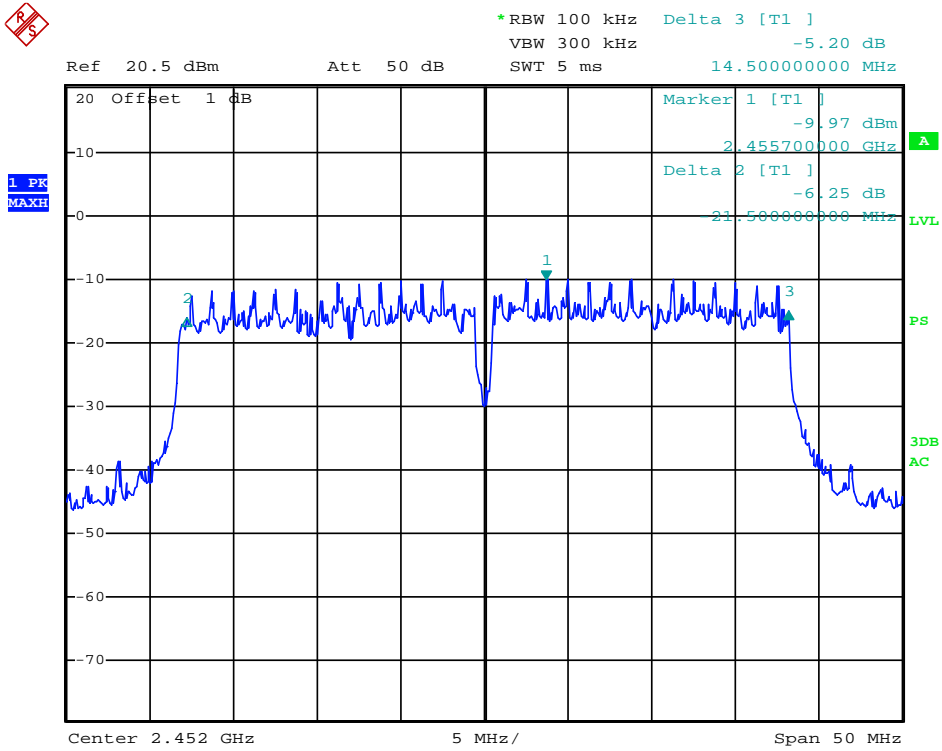

Date: 17.JAN.2014 15:28:42

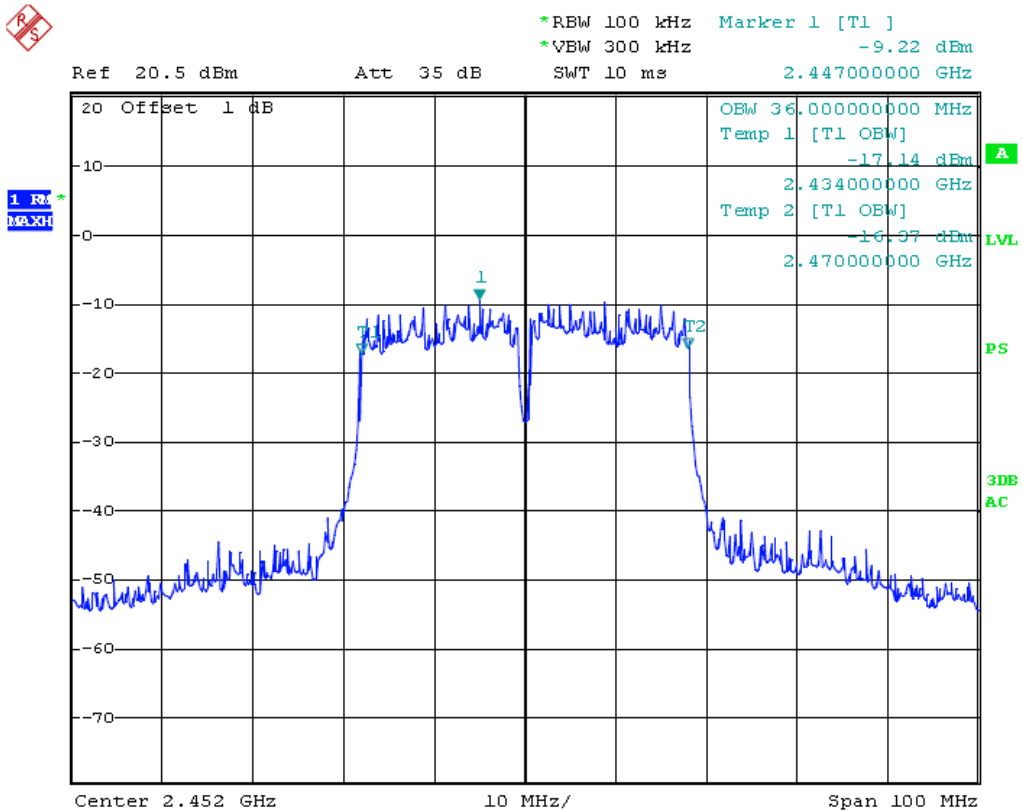

4.4. Maximum Peak Output Power

TEST CONFIGURATION

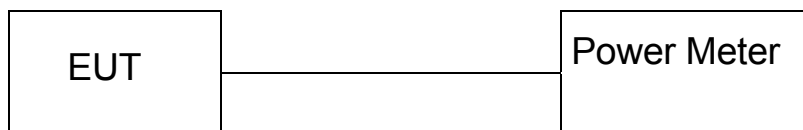

TEST PROCEDURE

According to C63.10 -2009 and KDB558074, The EUT was directly connected to the power meter / spectrum analyzer and antenna output port as show in the block diagram as TEST CONFIGURATION shows.

Use the wideband power meter to test peak power and record the result.

LIMIT

The Peak Output Power Measurement limits are 30dBm.

TEST RESULTS

Mode	Channel	Peak Power Output (dBm)	Peak Power Limit (dBm)	PASS / FAIL
802.11b	1	9.52	30	PASS
	6	9.05	30	PASS
	11	9.22	30	PASS
802.11g	1	9.26	30	PASS
	6	8.98	30	PASS
	11	9.45	30	PASS
802.11n HT20	1	9.17	30	PASS
	6	9.12	30	PASS
	11	9.05	30	PASS
802.11n HT40	3	8.46	30	PASS
	6	8.36	30	PASS
	9	8.29	30	PASS

Note: The test results including the cable lose.

4.5. Band Edge Measurement

TEST CONFIGURATION

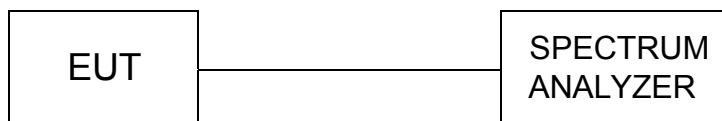

TEST PROCEDURE

The band edge compliance of RF radiated emission should be measured by following the guidance in ANSI C63.10 and FCC KDB Publication No. 558074 (Measurement Guidelines of DTS) with respect to maximizing the emission by rotating the EUT, measuring the emission while the EUT is situated in three orthogonal planes (if appropriate), adjusting the measurement antenna height and polarization etc. Set RBW=100kHz and VBM= 300KHz to measure the peak field strength and set RBW to 1MHz and VBW to 10Hz to measure the average radiated field strength.

The conducted RF band edge was measured by using a spectrum analyzer. Set span wide enough to capture the highest in-band emission and the emission at the band edge. Set RBW and VBW to 100 kHz, to measure the conducted peak band edge.

Connect the spectrum analyzer to the EUT using an appropriate RF cable connected to the EUT output. Configure the spectrum analyzer settings as described below (be sure to enter all losses between the unlicensed wireless device output and the spectrum analyzer).

- Span: Set Span for minimum 50 MHz - Reference Level: 110 dB μ V (corrected for gains and losses of test antenna factor, preamp gain and cable loss) - Attenuation: 10 dB
- Sweep Time: Coupled - Resolution Bandwidth: Up to and including 1 GHz = \geq 100 kHz
- Resolution Bandwidth: Above 1 GHz = 1 MHz - Video Bandwidth: Below 1 GHz = 300 kHz
- Video Bandwidth: Up to and including 1 GHz = \geq 3 MHz for peak and 10 Hz for average
- Detector: Peak

Place a marker at the end of the restricted band closest to the transmit frequency to show compliance. Also measure any emissions in the restricted bands. Save the spectrum analyzer plot. Repeat for each power and modulation for lowest and highest channel.

LIMIT

1. Below -20dB of the highest emission level in operating band.
2. Fall in the restricted bands listed in section 15.205. The maximum permitted average field strength is listed in section 15.209(see Section 15.205(c)).

Frequency (MHz)	Limit Average (dB μ v/m)	Limit Peak (dB μ v/m)
Below 2390 or Above 2483.5	54	74

TEST RESULTS

Limit: FCC_Part15.209_RE(3m)	Margin: 0
Probe: BBHA 9120D_499(1-18GHz)	Polarity: Horizontal
EUT: Tablet	Power: By Battery
Note: Mode 1: Transmit at channel 2412MHz by 802.11b	

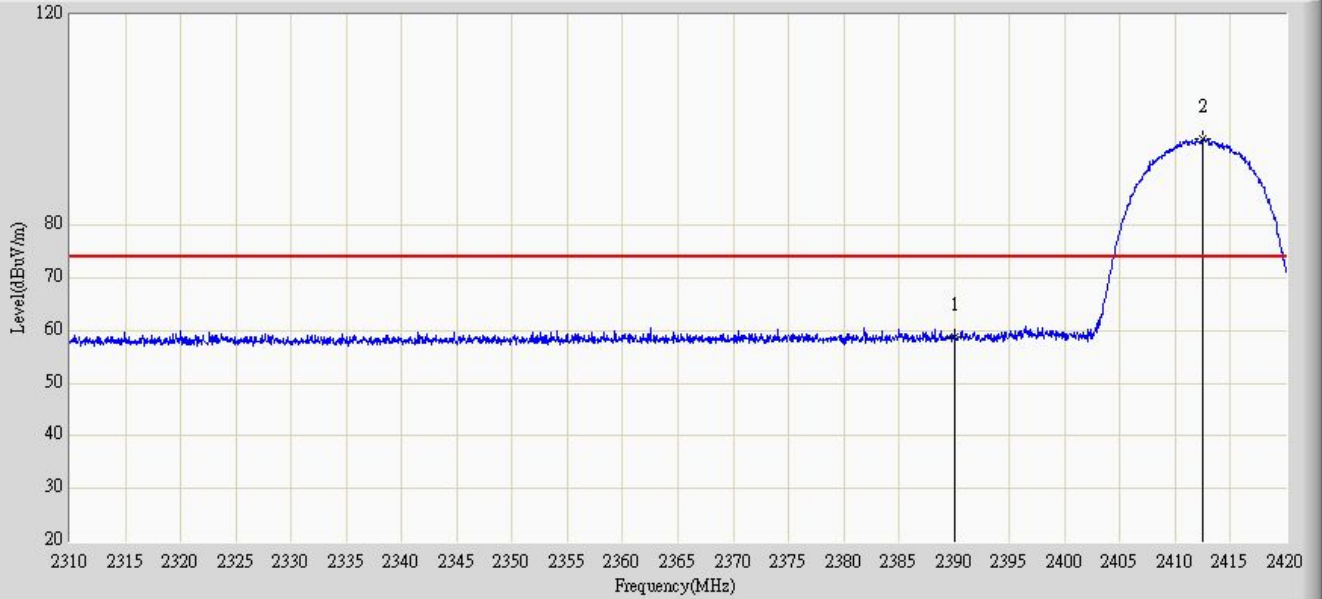

No	Flag	Mark	Frequency (MHz)	Measure Level (dBuV/m)	Reading Level (dBuV)	Over Limit (dB)	Limit (dBuV/m)	Factor	Type
1			2390.000	58.862	28.512	-15.138	74.000	30.350	PK
2		*	2412.520	96.312	65.908	N/A	N/A	30.404	PK

Limit: FCC_Part15.209_RE(3m)	Margin: 0
Probe: BBHA 9120D_499(1-18GHz)	Polarity: Horizontal
EUT: Tablet	Power: By Battery
Note: Mode 1: Transmit at channel 2412MHz by 802.11b	

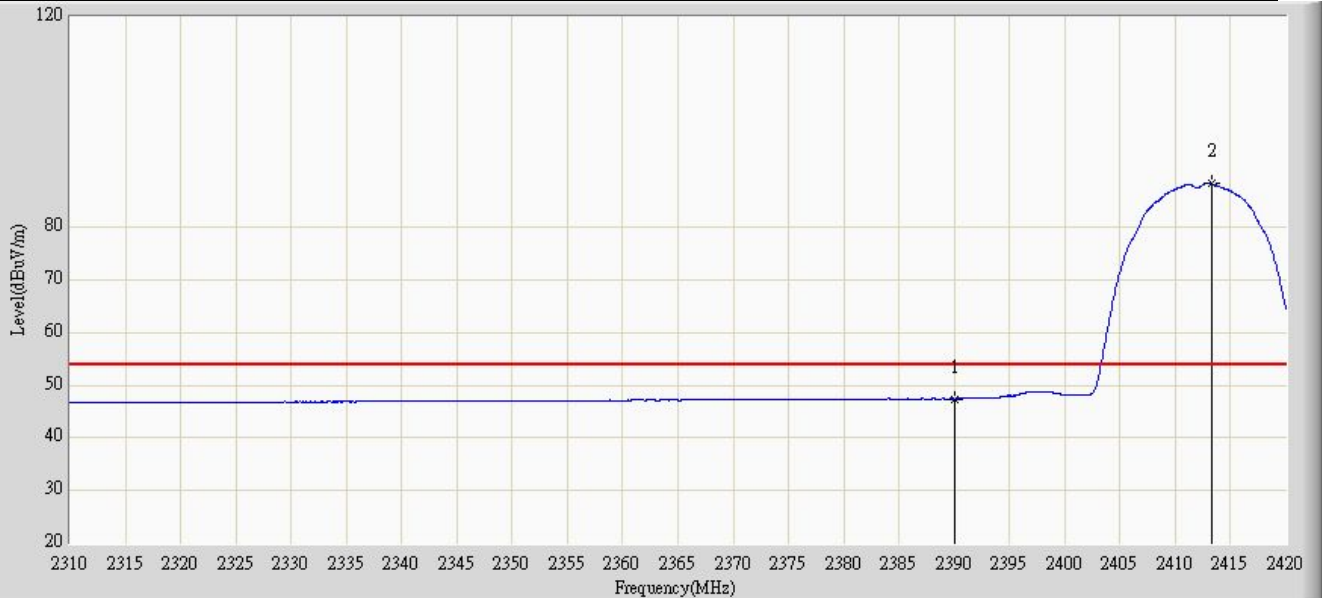

No	Flag	Mark	Frequency (MHz)	Measure Level (dBuV/m)	Reading Level (dBuV)	Over Limit (dB)	Limit (dBuV/m)	Factor	Type
1			2390.000	47.427	17.077	-6.573	54.000	30.350	AV
2		*	2413.290	88.252	57.846	N/A	N/A	30.406	AV

Limit: FCC_Part15.209_RE(3m)	Margin: 0
Probe: BBHA 9120D_499(1-18GHz)	Polarity: Vertical
EUT: Tablet	Power: By Battery
Note: Mode 1: Transmit at channel 2412MHz by 802.11b	

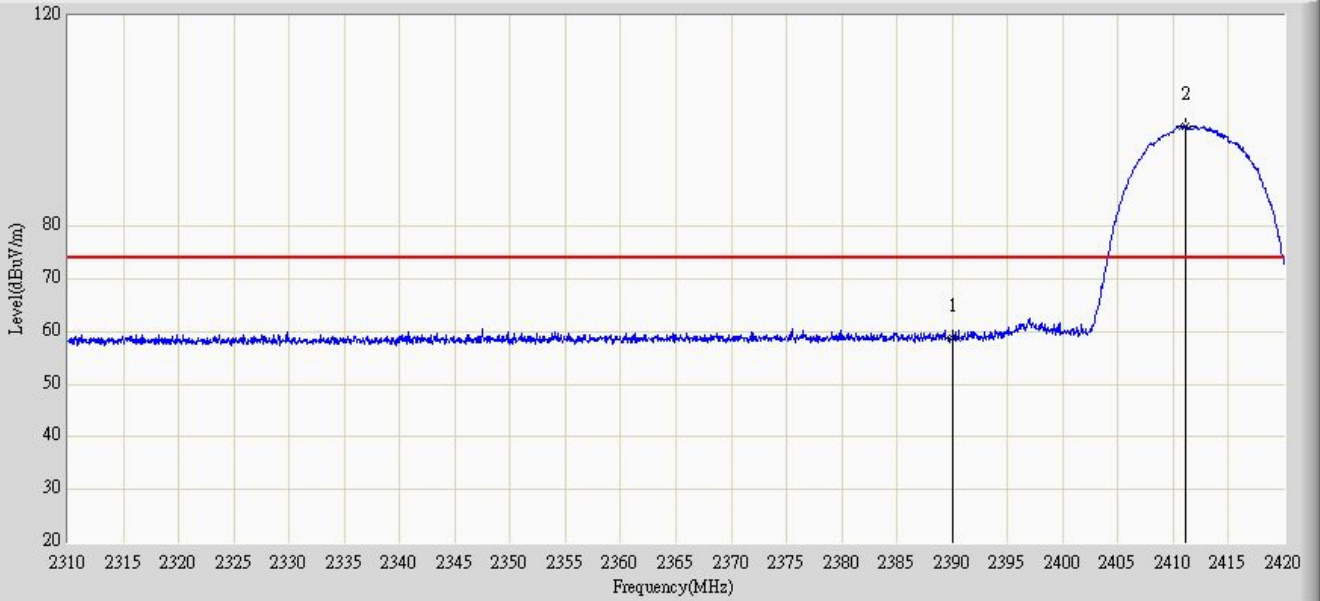

No	Flag	Mark	Frequency (MHz)	Measure Level (dBuV/m)	Reading Level (dBuV)	Over Limit (dB)	Limit (dBuV/m)	Factor	Type
1			2390.000	58.676	28.326	-15.324	74.000	30.350	PK
2		*	2411.145	99.093	68.693	N/A	N/A	30.400	PK

Limit: FCC_Part15.209_RE(3m)	Margin: 0
Probe: BBHA 9120D_499(1-18GHz)	Polarity: Vertical
EUT: Tablet	Power: By Battery
Note: Mode 1: Transmit at channel 2412MHz by 802.11b	

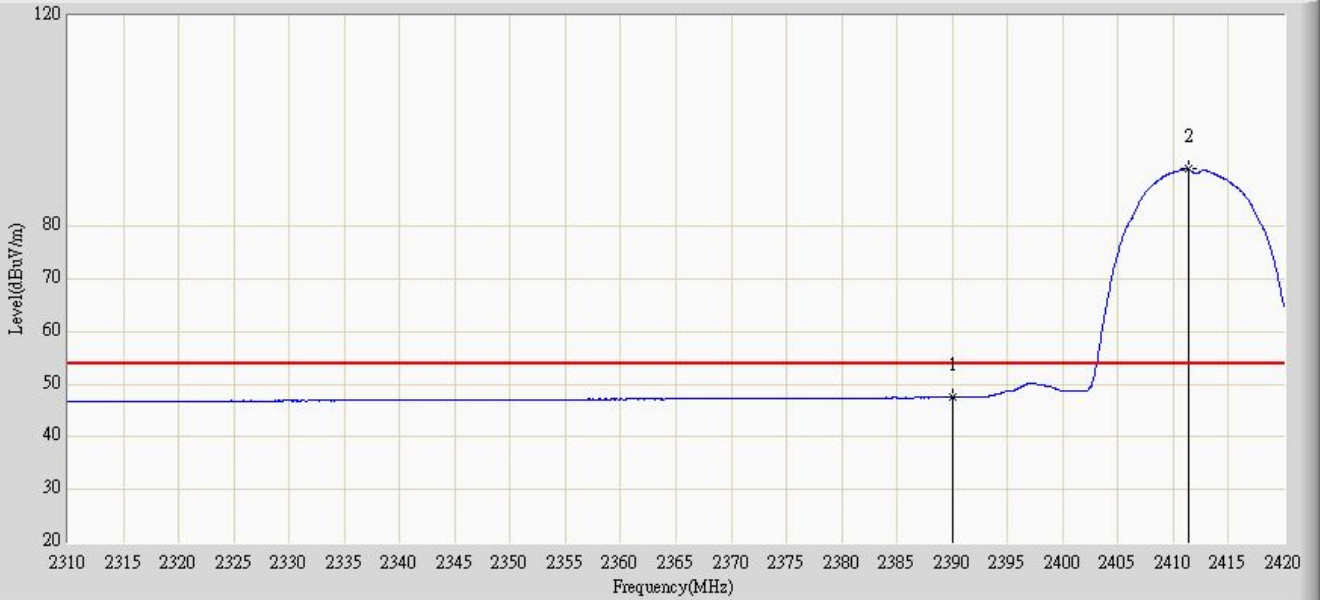

No	Flag	Mark	Frequency (MHz)	Measure Level (dBuV/m)	Reading Level (dBuV)	Over Limit (dB)	Limit (dBuV/m)	Factor	Type
1			2390.000	47.514	17.164	-6.486	54.000	30.350	AV
2		*	2411.365	90.880	60.479	N/A	N/A	30.401	AV

Limit: FCC_Part15.209_RE(3m)	Margin: 0
Probe: BBHA 9120D_499(1-18GHz)	Polarity: Horizontal
EUT: Tablet	Power: By Battery
Note: Mode 1: Transmit at channel 2462MHz by 802.11b	

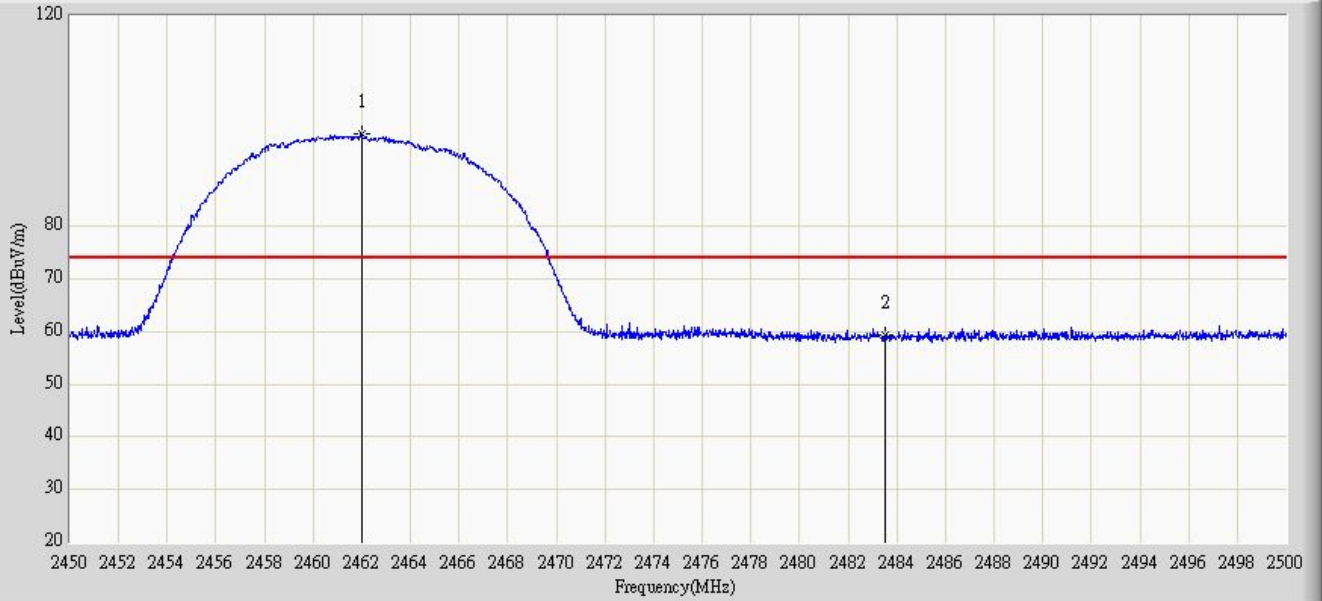

No	Flag	Mark	Frequency (MHz)	Measure Level (dBuV/m)	Reading Level (dBuV)	Over Limit (dB)	Limit (dBuV/m)	Factor	Type
1		*	2461.975	97.522	66.987	N/A	N/A	30.535	PK
2			2483.500	59.445	28.853	-14.555	74.000	30.592	PK

Limit: FCC_Part15.209_RE(3m)	Margin: 0
Probe: BBHA 9120D_499(1-18GHz)	Polarity: Horizontal
EUT: Tablet	Power: By Battery
Note: Mode 1: Transmit at channel 2462MHz by 802.11b	

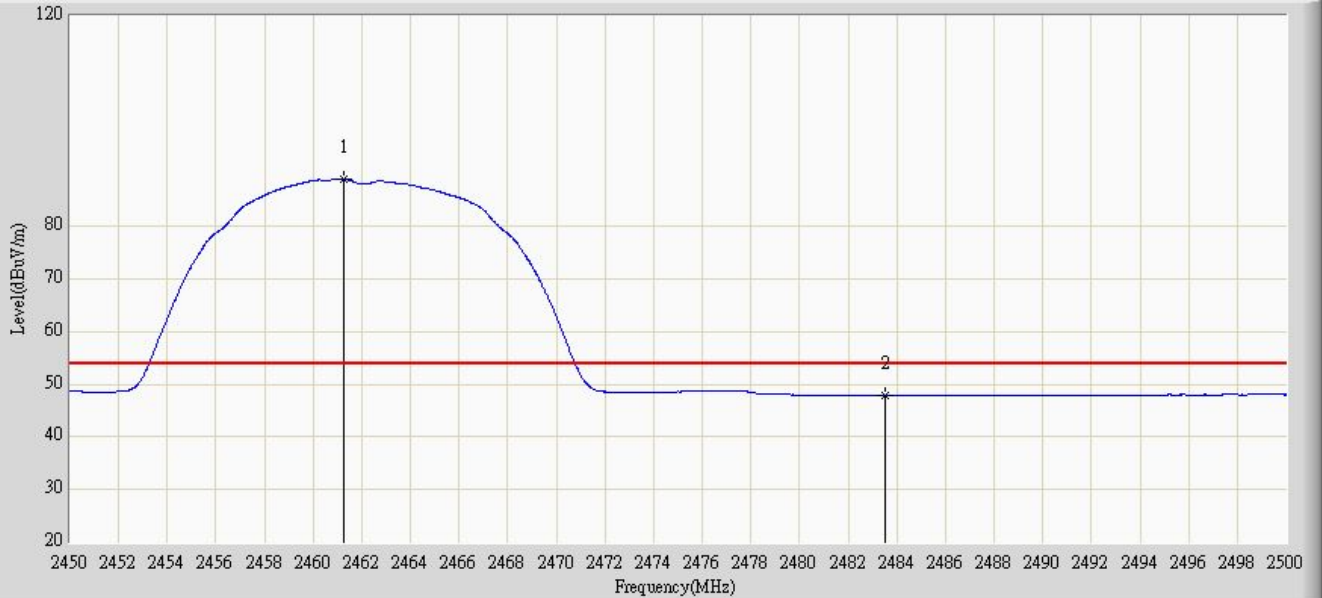

No	Flag	Mark	Frequency (MHz)	Measure Level (dBuV/m)	Reading Level (dBuV)	Over Limit (dB)	Limit (dBuV/m)	Factor	Type
1		*	2461.250	88.941	58.408	N/A	N/A	30.533	AV
2			2483.500	47.832	17.240	-6.168	54.000	30.592	AV

Limit: FCC_Part15.209_RE(3m)	Margin: 0
Probe: BBHA 9120D_499(1-18GHz)	Polarity: Vertical
EUT: Tablet	Power: By Battery
Note: Mode 1: Transmit at channel 2462MHz by 802.11b	

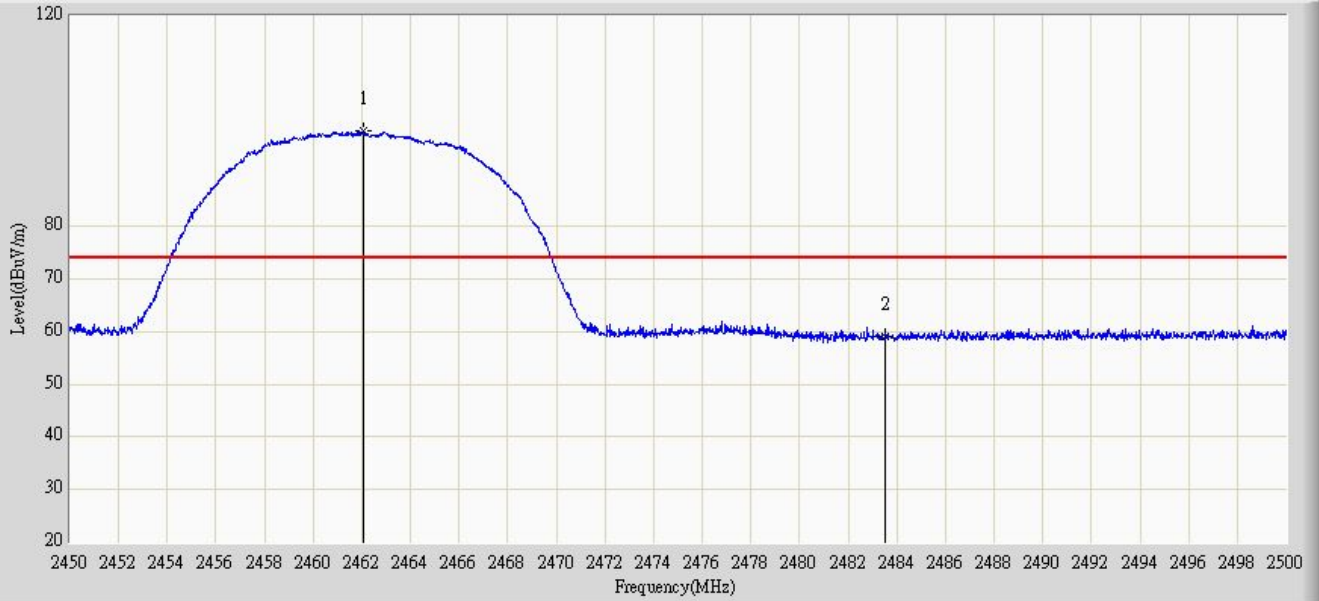

No	Flag	Mark	Frequency (MHz)	Measure Level (dBuV/m)	Reading Level (dBuV)	Over Limit (dB)	Limit (dBuV/m)	Factor	Type
1		*	2462.050	98.180	67.645	N/A	N/A	30.535	PK
2			2483.500	58.954	28.362	-15.046	74.000	30.592	PK

Limit: FCC_Part15.209_RE(3m)	Margin: 0
Probe: BBHA 9120D_499(1-18GHz)	Polarity: Vertical
EUT: Tablet	Power: By Battery
Note: Mode 1: Transmit at channel 2462MHz by 802.11b	

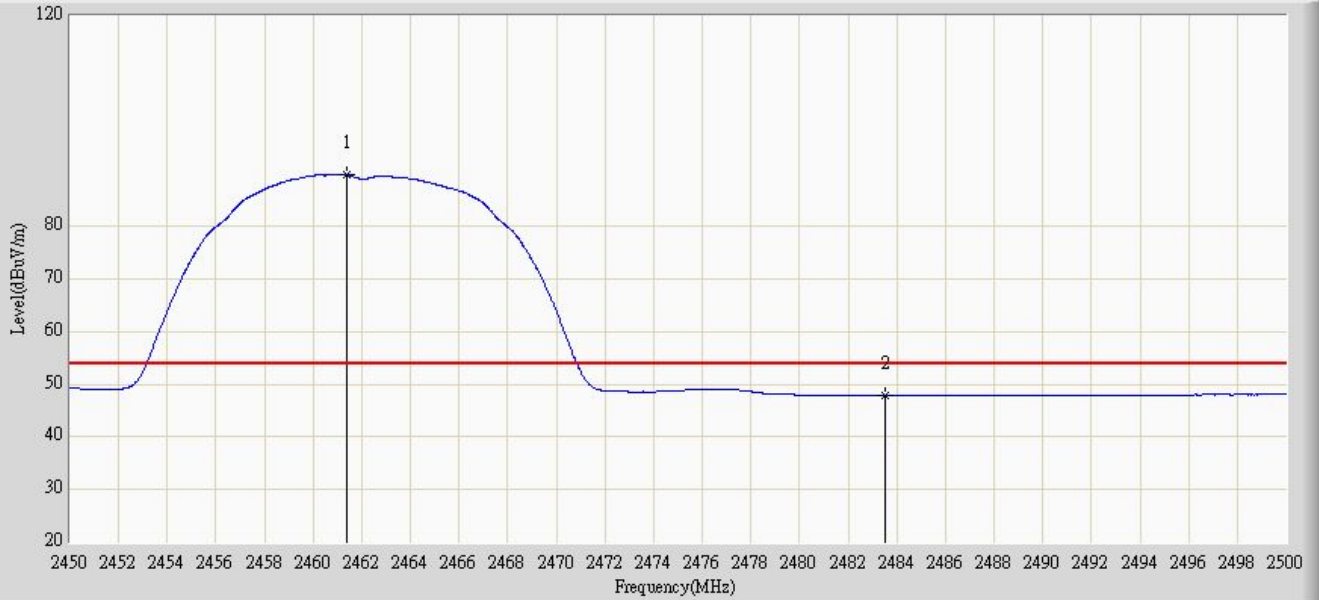

No	Flag	Mark	Frequency (MHz)	Measure Level (dBuV/m)	Reading Level (dBuV)	Over Limit (dB)	Limit (dBuV/m)	Factor	Type
1		*	2461.400	89.782	59.249	N/A	N/A	30.533	AV
2			2483.500	47.878	17.286	-6.122	54.000	30.592	AV

Limit: FCC_Part15.209_RE(3m)	Margin: 0
Probe: BBHA 9120D_499(1-18GHz)	Polarity: Horizontal
EUT: Tablet	Power: By Battery
Note: Mode 2: Transmit at channel 2412MHz by 802.11g	

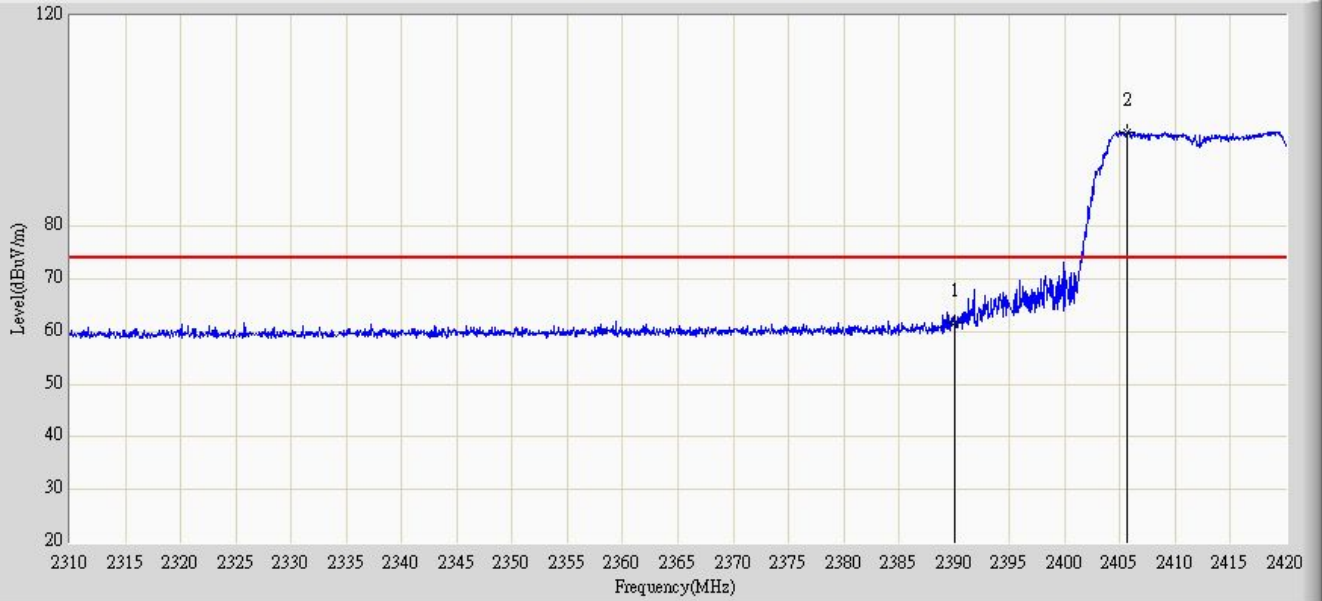

No	Flag	Mark	Frequency (MHz)	Measure Level (dBuV/m)	Reading Level (dBuV)	Over Limit (dB)	Limit (dBuV/m)	Factor	Type
1			2390.000	61.588	31.238	-12.412	74.000	30.350	PK
2		*	2405.590	97.808	67.420	N/A	N/A	30.388	PK

Limit: FCC_Part15.209_RE(3m)	Margin: 0
Probe: BBHA 9120D_499(1-18GHz)	Polarity: Horizontal
EUT: Tablet	Power: By Battery
Note: Mode 2: Transmit at channel 2412MHz by 802.11g	

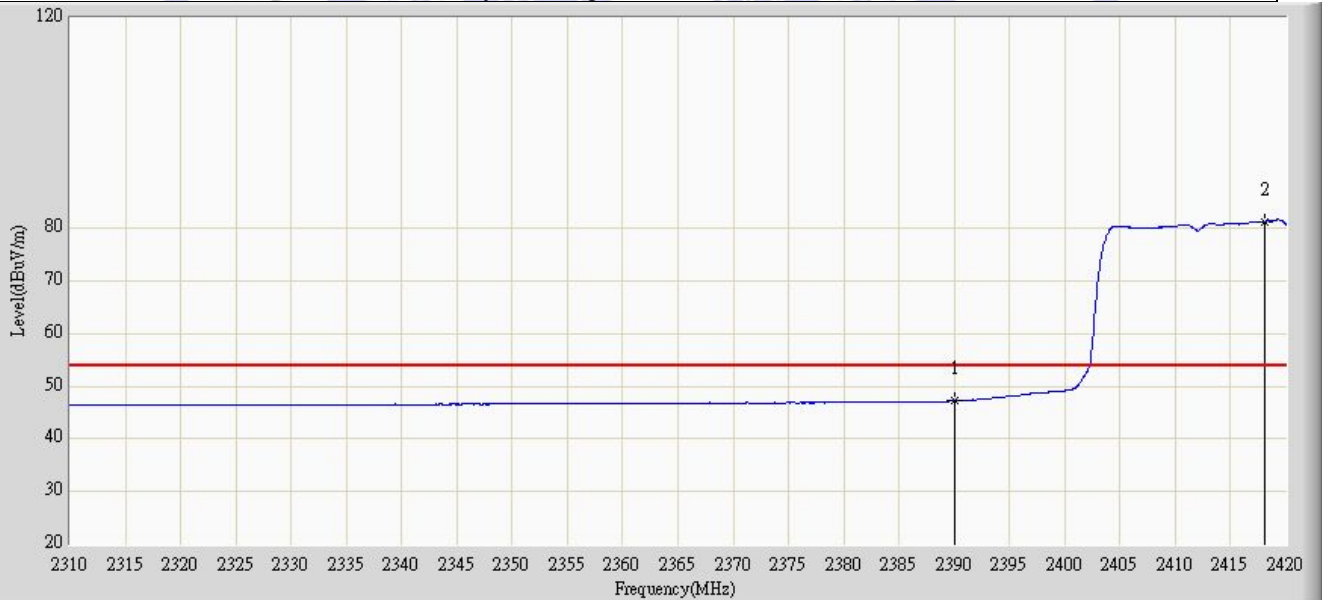

No	Flag	Mark	Frequency (MHz)	Measure Level (dBuV/m)	Reading Level (dBuV)	Over Limit (dB)	Limit (dBuV/m)	Factor	Type
1			2390.000	47.204	16.854	-6.796	54.000	30.350	AV
2		*	2418.130	81.347	50.928	N/A	N/A	30.420	AV

Limit: FCC_Part15.209_RE(3m)	Margin: 0
Probe: BBHA 9120D_499(1-18GHz)	Polarity: Vertical
EUT: Tablet	Power: By Battery
Note: Mode 2: Transmit at channel 2412MHz by 802.11g	

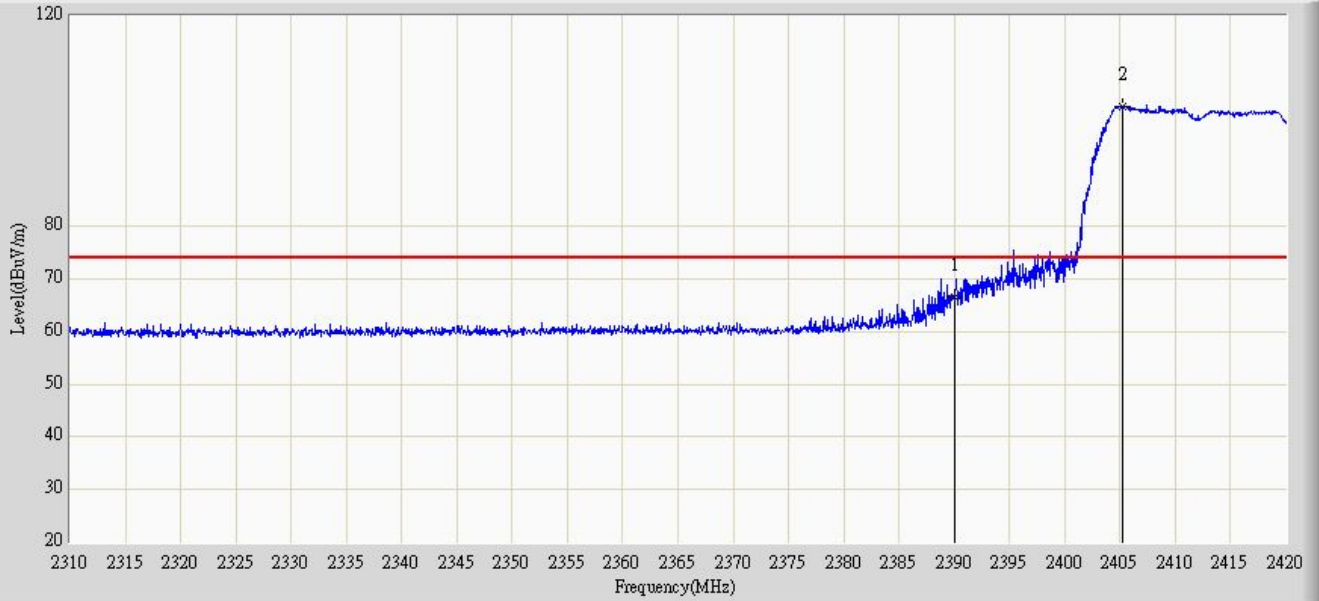

No	Flag	Mark	Frequency (MHz)	Measure Level (dBuV/m)	Reading Level (dBuV)	Over Limit (dB)	Limit (dBuV/m)	Factor	Type
1			2390.000	66.646	36.296	-7.354	74.000	30.350	PK
2		*	2405.260	102.819	72.432	N/A	N/A	30.388	PK

Limit: FCC_Part15.209_RE(3m)	Margin: 0
Probe: BBHA 9120D_499(1-18GHz)	Polarity: Vertical
EUT: Tablet	Power: By Battery
Note: Mode 2: Transmit at channel 2412MHz by 802.11g	

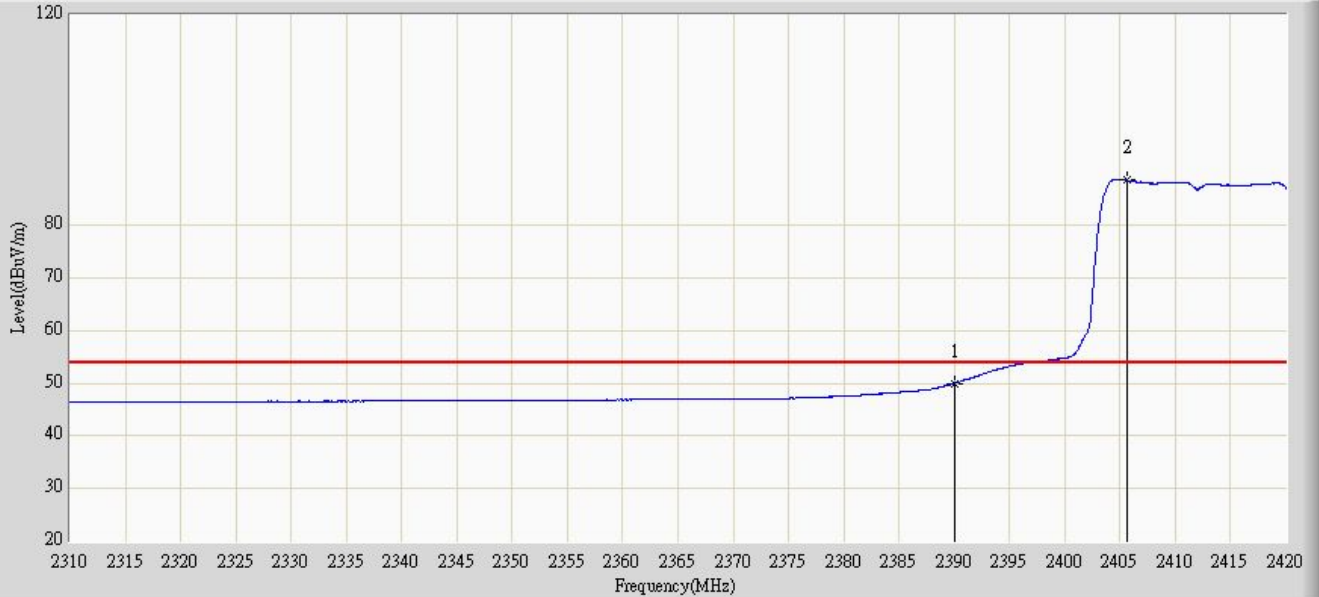

No	Flag	Mark	Frequency (MHz)	Measure Level (dBuV/m)	Reading Level (dBuV)	Over Limit (dB)	Limit (dBuV/m)	Factor	Type
1			2390.000	49.990	19.640	-4.010	54.000	30.350	AV
2		*	2405.590	88.591	58.203	N/A	N/A	30.388	AV

Limit: FCC_Part15.209_RE(3m)	Margin: 0
Probe: BBHA 9120D_499(1-18GHz)	Polarity: Horizontal
EUT: Tablet	Power: By Battery
Note: Mode 2: Transmit at channel 2462MHz by 802.11g	

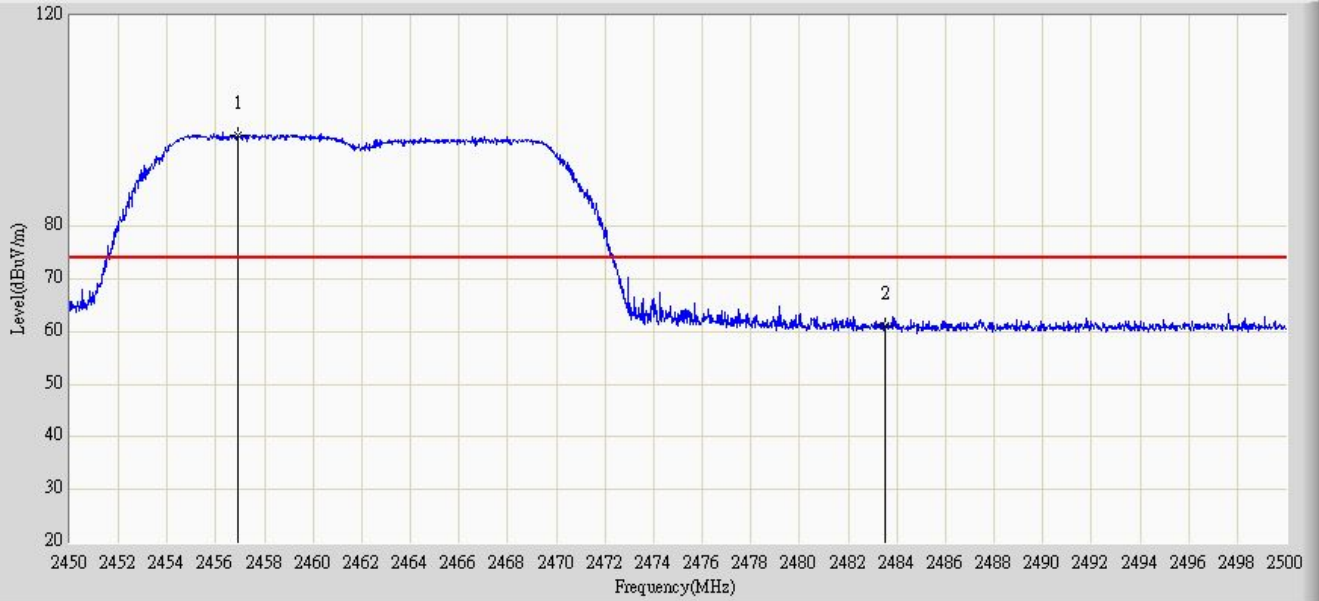

No	Flag	Mark	Frequency (MHz)	Measure Level (dBuV/m)	Reading Level (dBuV)	Over Limit (dB)	Limit (dBuV/m)	Factor	Type
1		*	2456.900	97.264	66.744	N/A	N/A	30.521	PK
2			2483.500	61.192	30.600	-12.808	74.000	30.592	PK

Engineer:	
Site: AC5	Time: 2012/08/13 - 10:07
Limit: FCC_Part15.209_RE(3m)	Margin: 0
Probe: BBHA 9120D_499(1-18GHz)	Polarity: Horizontal
EUT: Tablet	Power: By Battery
Note: Mode 2: Transmit at channel 2462MHz by 802.11g	

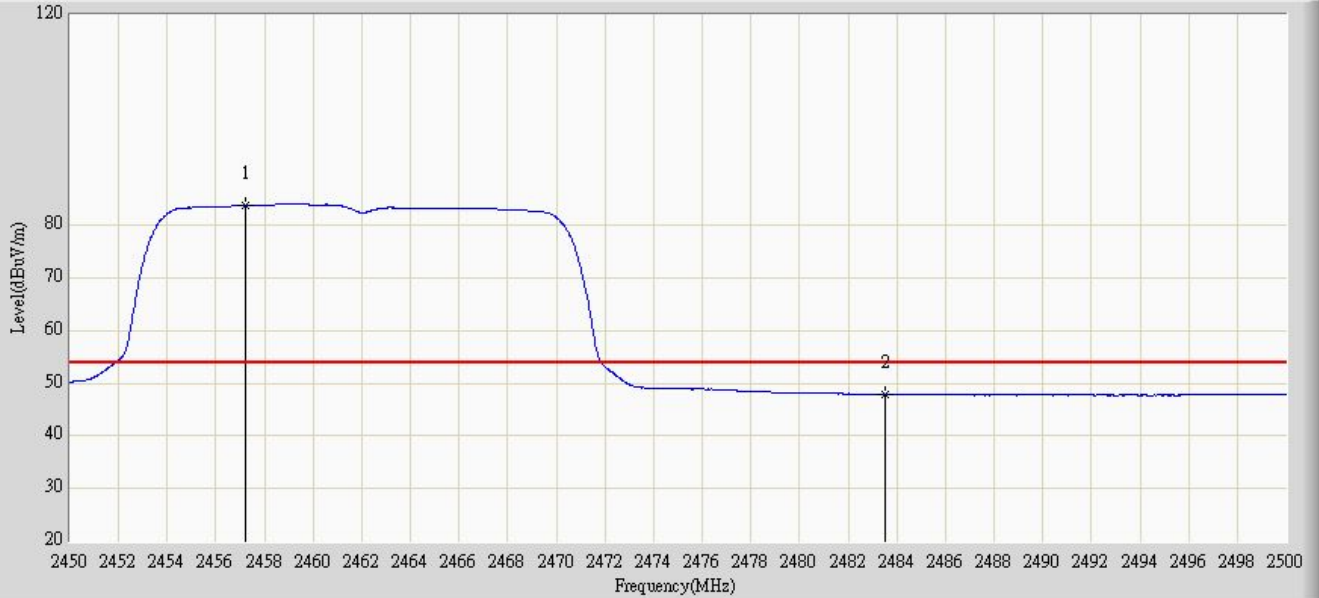

No	Flag	Mark	Frequency (MHz)	Measure Level (dBuV/m)	Reading Level (dBuV)	Over Limit (dB)	Limit (dBuV/m)	Factor	Type
1		*	2457.225	83.822	53.301	N/A	N/A	30.521	AV
2			2483.500	47.937	17.345	-6.063	54.000	30.592	AV

Limit: FCC_Part15.209_RE(3m)	Margin: 0
Probe: BBHA 9120D_499(1-18GHz)	Polarity: Vertical
EUT: Tablet	Power: By Battery
Note: Mode 2: Transmit at channel 2462MHz by 802.11g	

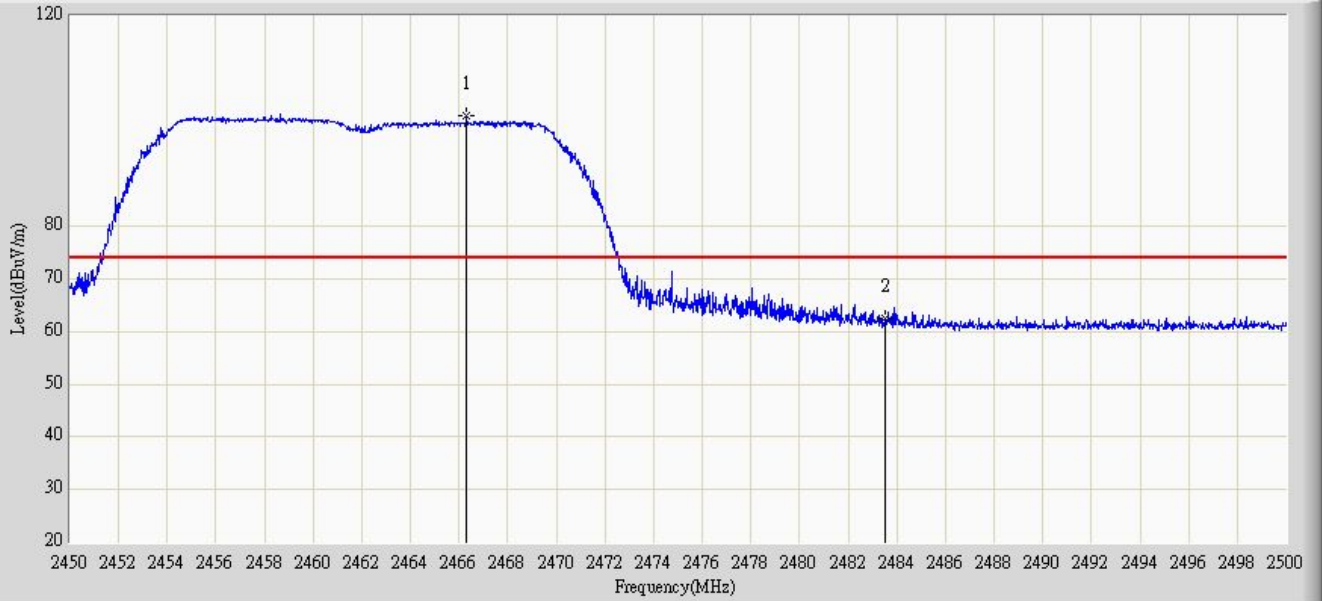

No	Flag	Mark	Frequency (MHz)	Measure Level (dBuV/m)	Reading Level (dBuV)	Over Limit (dB)	Limit (dBuV/m)	Factor	Type
1		*	2466.300	101.027	70.481	N/A	N/A	30.546	PK
2			2483.500	62.544	31.952	-11.456	74.000	30.592	PK

Limit: FCC_Part15.209_RE(3m)	Margin: 0
Probe: BBHA 9120D_499(1-18GHz)	Polarity: Vertical
EUT: Tablet	Power: By Battery
Note: Mode 2: Transmit at channel 2462MHz by 802.11g	

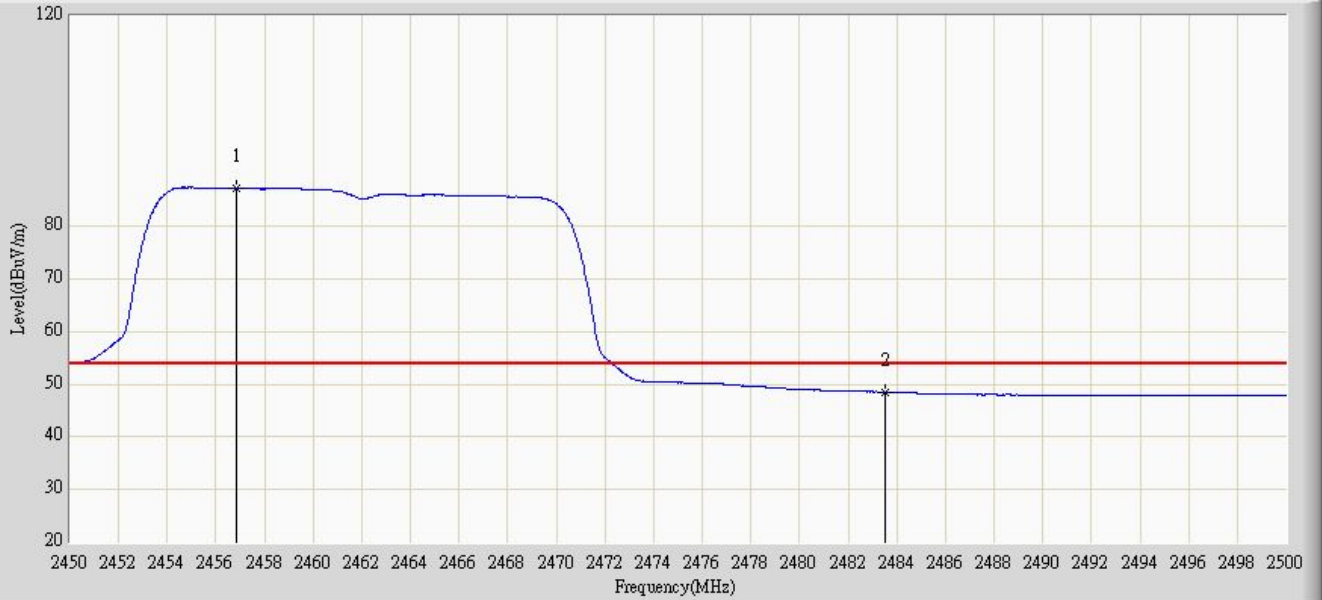

No	Flag	Mark	Frequency (MHz)	Measure Level (dBuV/m)	Reading Level (dBuV)	Over Limit (dB)	Limit (dBuV/m)	Factor	Type
1		*	2456.825	87.238	56.718	N/A	N/A	30.521	AV
2			2483.500	48.528	17.936	-5.472	54.000	30.592	AV

Limit: FCC_Part15.209_RE(3m)	Margin: 0
Probe: BBHA 9120D_499(1-18GHz)	Polarity: Horizontal
EUT: Tablet	Power: By Battery
Note: Mode 3: Transmit at channel 2412MHz by 802.11n(20)	

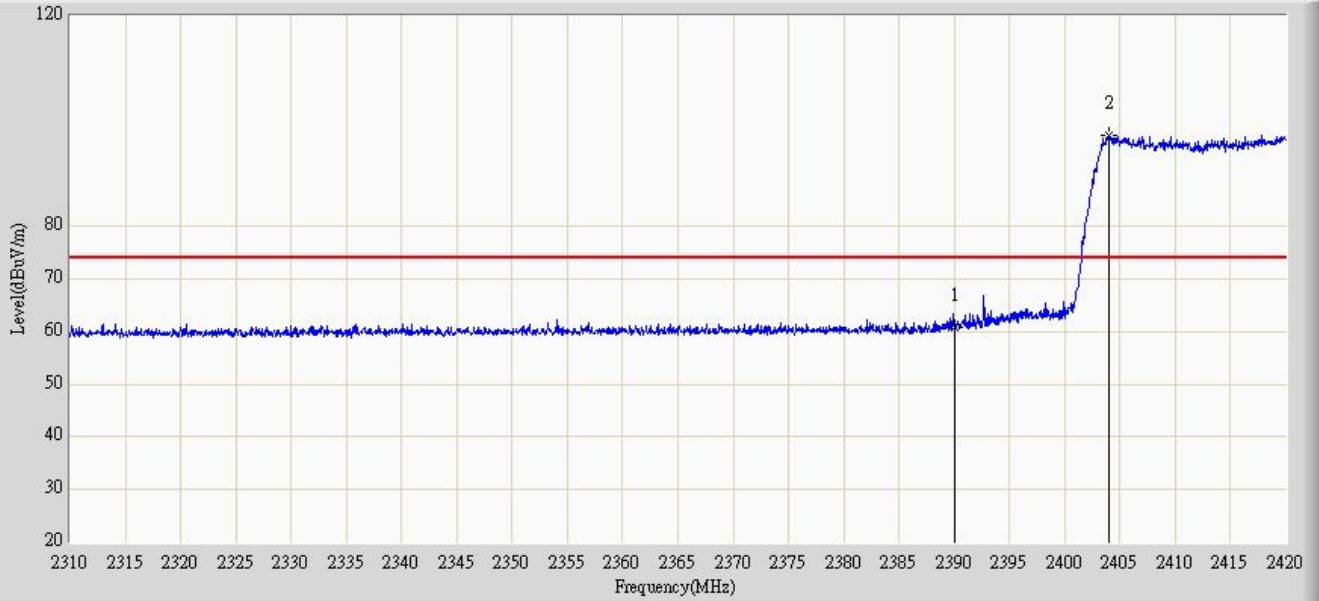

No	Flag	Mark	Frequency (MHz)	Measure Level (dBuV/m)	Reading Level (dBuV)	Over Limit (dB)	Limit (dBuV/m)	Factor	Type
1			2390.000	60.818	30.468	-13.182	74.000	30.350	PK
2		*	2404.050	97.209	66.825	N/A	N/A	30.384	PK

Limit: FCC_Part15.209_RE(3m)	Margin: 0
Probe: BBHA 9120D_499(1-18GHz)	Polarity: Horizontal
EUT: Tablet	Power: By Battery
Note: Mode 3: Transmit at channel 2412MHz by 802.11n(20)	

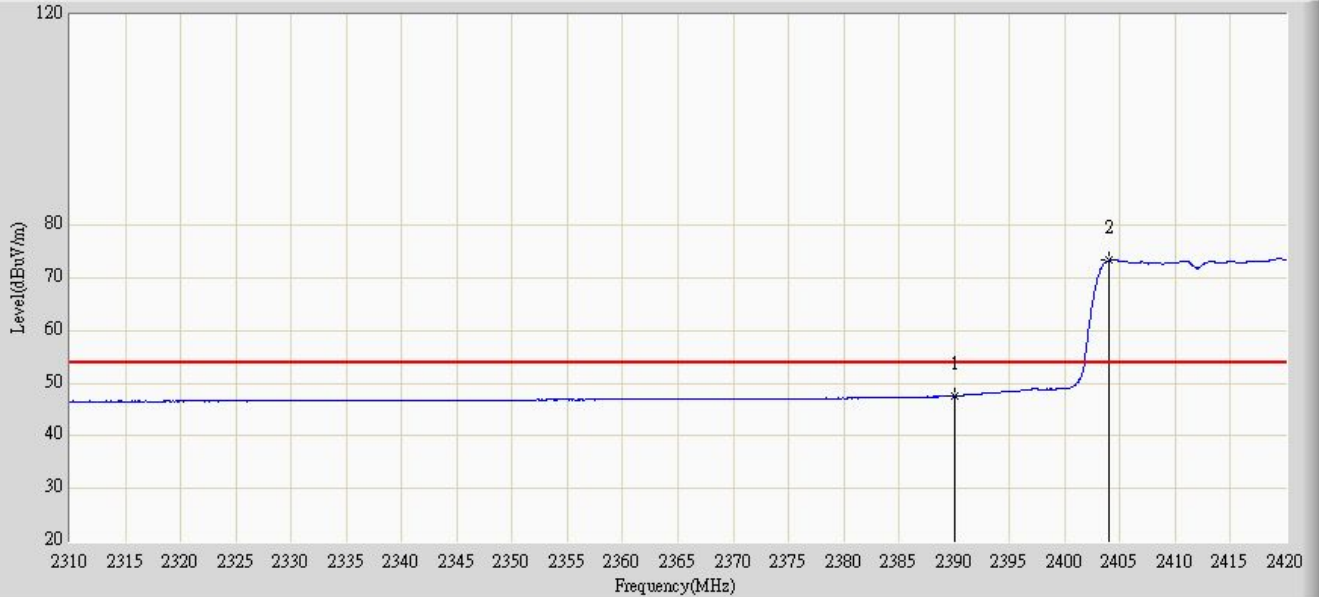

No	Flag	Mark	Frequency (MHz)	Measure Level (dBuV/m)	Reading Level (dBuV)	Over Limit (dB)	Limit (dBuV/m)	Factor	Type
1			2390.000	47.600	17.250	-6.400	54.000	30.350	AV
2		*	2404.050	73.357	42.973	N/A	N/A	30.384	AV

Limit: FCC_Part15.209_RE(3m)	Margin: 0
Probe: BBHA 9120D_499(1-18GHz)	Polarity: Vertical
EUT: Tablet	Power: By Battery
Note: Mode 3: Transmit at channel 2412MHz by 802.11n(20)	

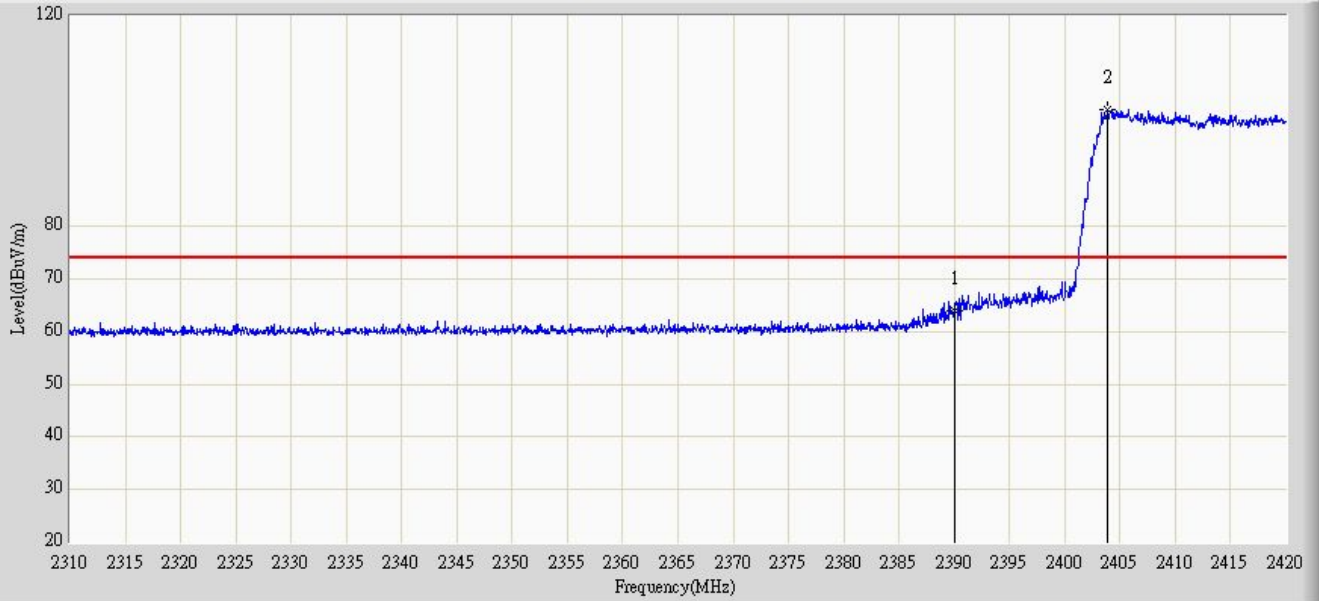

No	Flag	Mark	Frequency (MHz)	Measure Level (dBuV/m)	Reading Level (dBuV)	Over Limit (dB)	Limit (dBuV/m)	Factor	Type
1			2390.000	64.071	33.721	-9.929	74.000	30.350	PK
2		*	2403.885	102.224	71.840	N/A	N/A	30.384	PK

Limit: FCC_Part15.209_RE(3m)	Margin: 0
Probe: BBHA 9120D_499(1-18GHz)	Polarity: Vertical
EUT: Tablet	Power: By Battery
Note: Mode 3: Transmit at channel 2412MHz by 802.11n(20)	

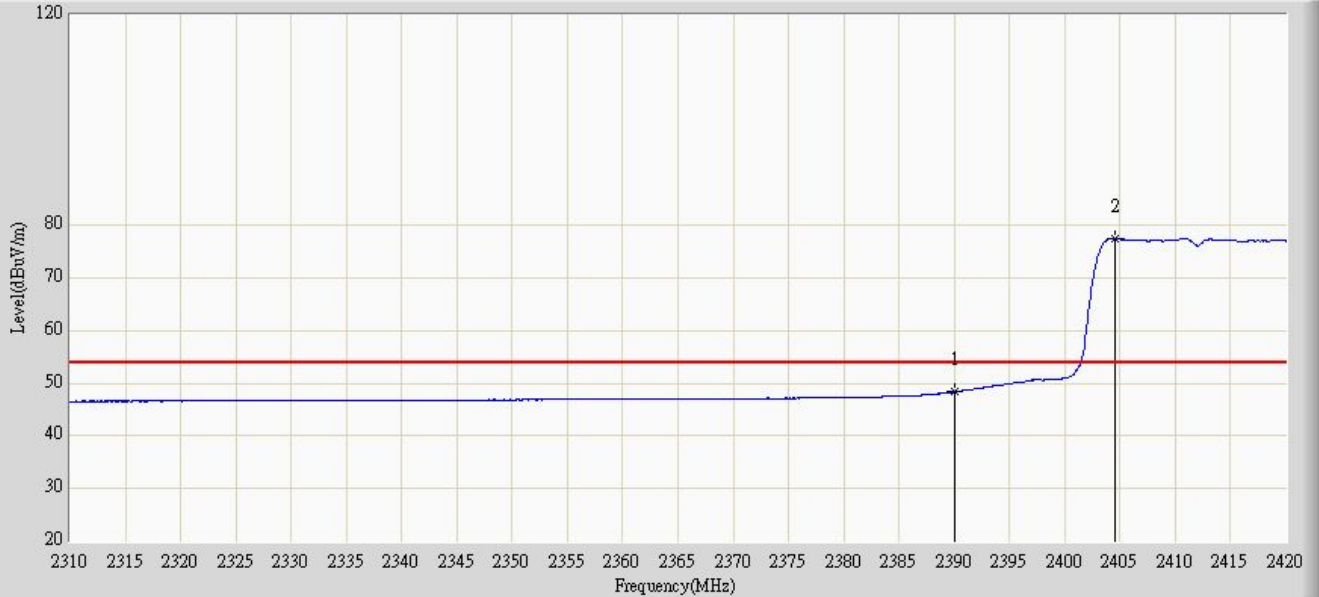

No	Flag	Mark	Frequency (MHz)	Measure Level (dBuV/m)	Reading Level (dBuV)	Over Limit (dB)	Limit (dBuV/m)	Factor	Type
1			2390.000	48.384	18.034	-5.616	54.000	30.350	AV
2		*	2404.545	77.489	47.103	N/A	N/A	30.385	AV

Limit: FCC_Part15.209_RE(3m)	Margin: 0
Probe: BBHA 9120D_499(1-18GHz)	Polarity: Horizontal
EUT: Tablet	Power: By Battery
Note: Mode 3: Transmit at channel 2462MHz by 802.11n(20)	

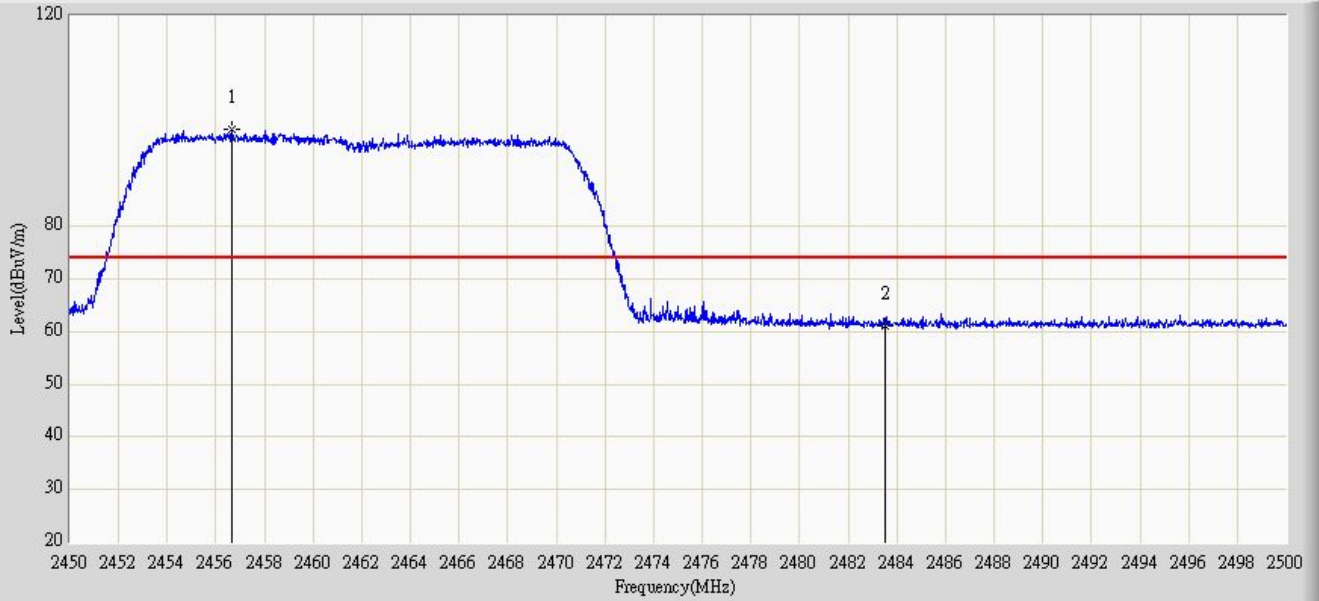

No	Flag	Mark	Frequency (MHz)	Measure Level (dBuV/m)	Reading Level (dBuV)	Over Limit (dB)	Limit (dBuV/m)	Factor	Type
1		*	2456.675	98.533	68.013	N/A	N/A	30.519	PK
2			2483.500	60.952	30.360	-13.048	74.000	30.592	PK

Limit: FCC_Part15.209_RE(3m)	Margin: 0
Probe: BBHA 9120D_499(1-18GHz)	Polarity: Horizontal
EUT: Tablet	Power: By Battery
Note: Mode 3: Transmit at channel 2462MHz by 802.11n(20)	

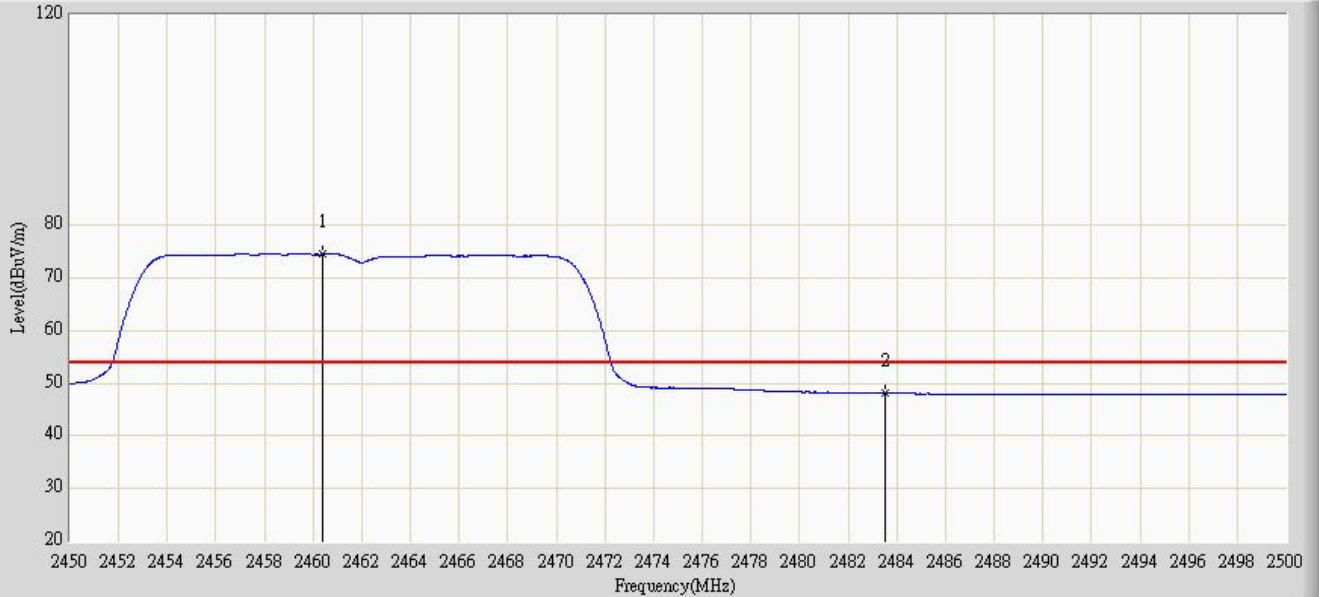

No	Flag	Mark	Frequency (MHz)	Measure Level (dBuV/m)	Reading Level (dBuV)	Over Limit (dB)	Limit (dBuV/m)	Factor	Type
1		*	2460.400	74.523	43.993	N/A	N/A	30.530	AV
2			2483.500	48.151	17.559	-5.849	54.000	30.592	AV

Limit: FCC_Part15.209_RE(3m)	Margin: 0
Probe: BBHA 9120D_499(1-18GHz)	Polarity: Vertical
EUT: Tablet	Power: By Battery
Note: Mode 3: Transmit at channel 2462MHz by 802.11n(20)	

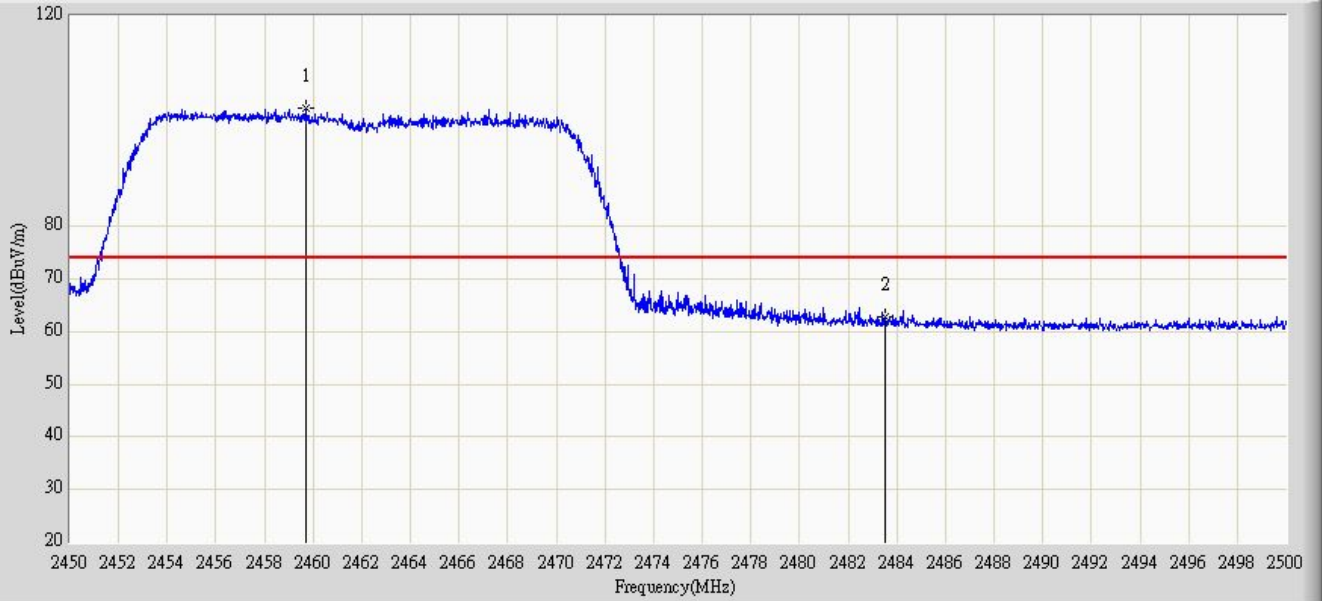

No	Flag	Mark	Frequency (MHz)	Measure Level (dBuV/m)	Reading Level (dBuV)	Over Limit (dB)	Limit (dBuV/m)	Factor	Type
1		*	2459.725	102.497	71.969	N/A	N/A	30.529	PK
2			2483.500	62.872	32.280	-11.128	74.000	30.592	PK

Limit: FCC_Part15.209_RE(3m)	Margin: 0
Probe: BBHA 9120D_499(1-18GHz)	Polarity: Vertical
EUT: Tablet	Power: By Battery
Note: Mode 3: Transmit at channel 2462MHz by 802.11n(20)	

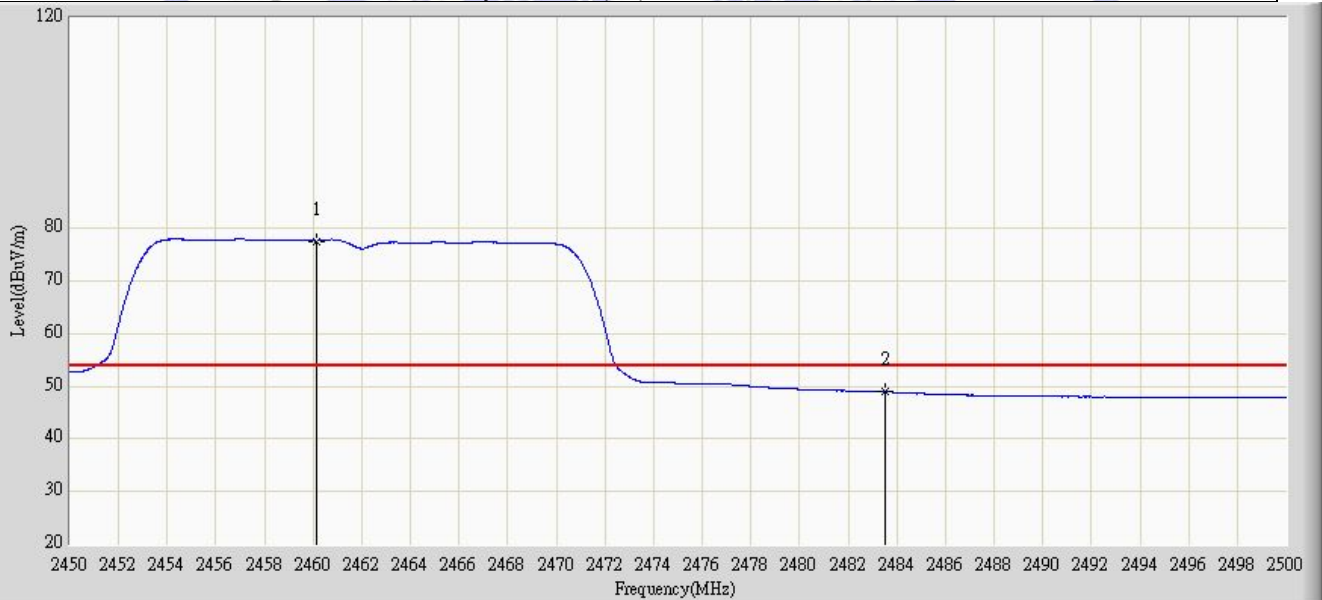

No	Flag	Mark	Frequency (MHz)	Measure Level (dBuV/m)	Reading Level (dBuV)	Over Limit (dB)	Limit (dBuV/m)	Factor	Type
1		*	2460.150	77.609	47.079	N/A	N/A	30.530	AV
2			2483.500	48.976	18.384	-5.024	54.000	30.592	AV

Limit: FCC_Part15.209_RE(3m)	Margin: 0
Probe: BBHA 9120D_499(1-18GHz)	Polarity: Horizontal
EUT: Tablet	Power: By Battery
Note: Mode 4: Transmit at channel 2422MHz by 802.11n(40)	

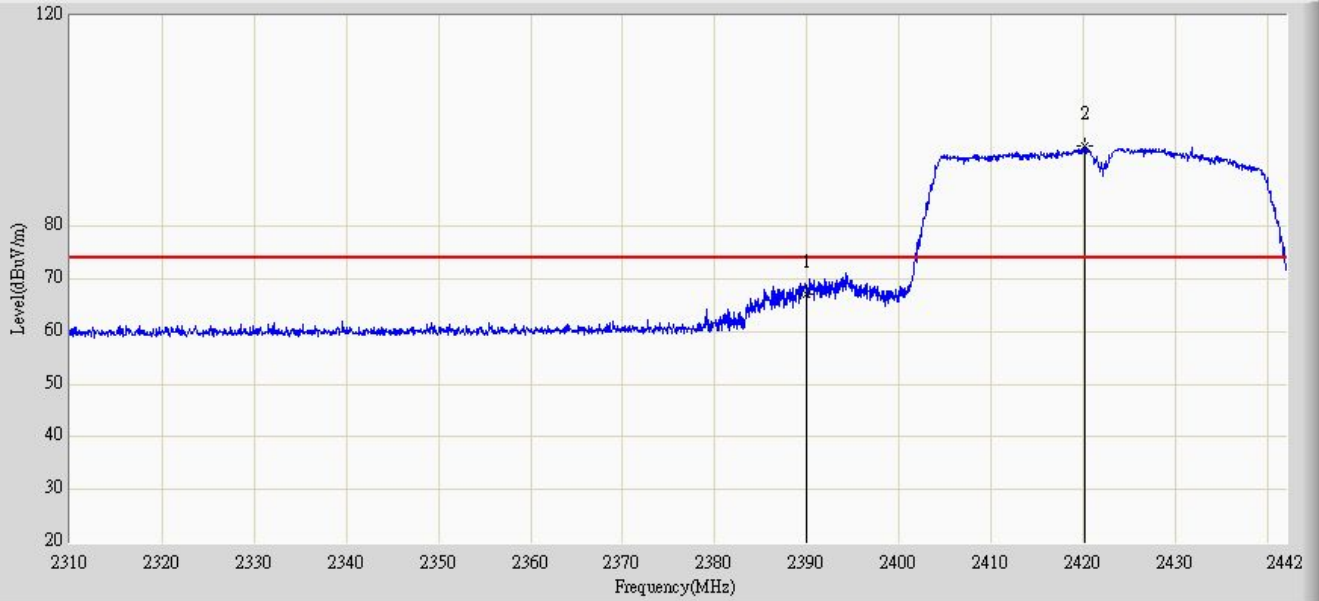

No	Flag	Mark	Frequency (MHz)	Measure Level (dBuV/m)	Reading Level (dBuV)	Over Limit (dB)	Limit (dBuV/m)	Factor	Type
1			2390.000	67.109	36.759	-6.891	74.000	30.350	PK
2		*	2420.088	95.365	64.940	N/A	N/A	30.425	PK

Limit: FCC_Part15.209_RE(3m)	Margin: 0
Probe: BBHA 9120D_499(1-18GHz)	Polarity: Horizontal
EUT: Tablet	Power: By Battery
Note: Mode 4: Transmit at channel 2422MHz by 802.11n(40)	

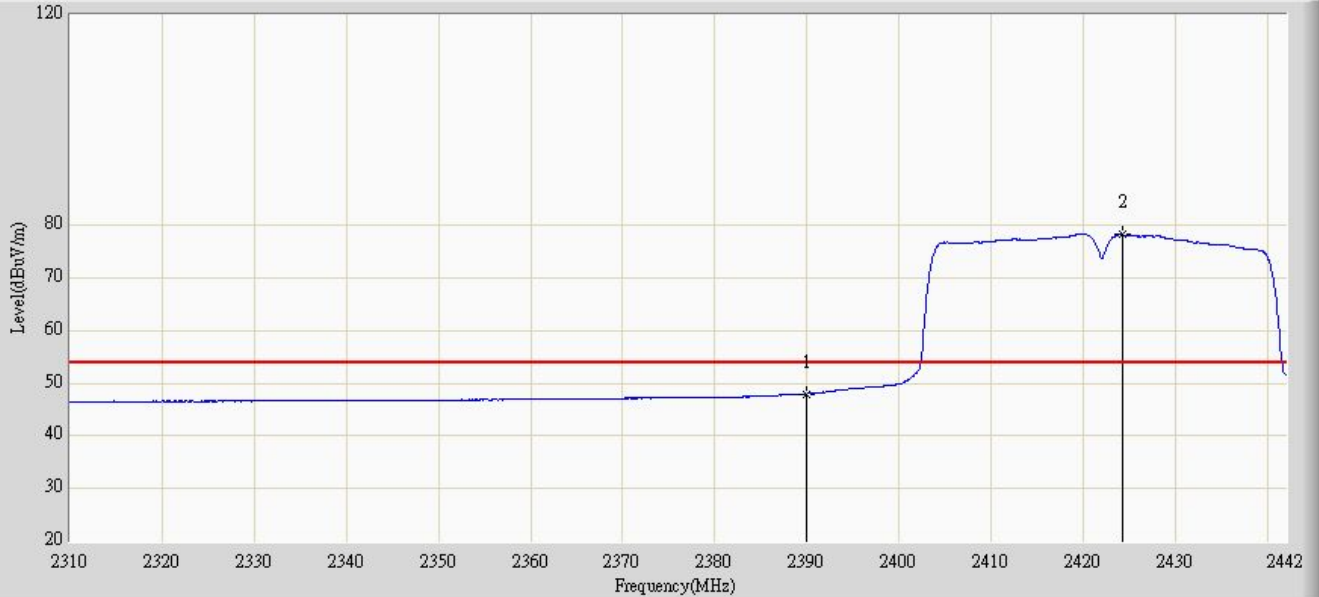

No	Flag	Mark	Frequency (MHz)	Measure Level (dBuV/m)	Reading Level (dBuV)	Over Limit (dB)	Limit (dBuV/m)	Factor	Type
1			2390.000	48.014	17.664	-5.986	54.000	30.350	AV
2		*	2424.246	78.236	47.800	N/A	N/A	30.435	AV

Limit: FCC_Part15.209_RE(3m)	Margin: 0
Probe: BBHA 9120D_499(1-18GHz)	Polarity: Vertical
EUT: Tablet	Power: By Battery
Note: Mode 4: Transmit at channel 2422MHz by 802.11n(40)	

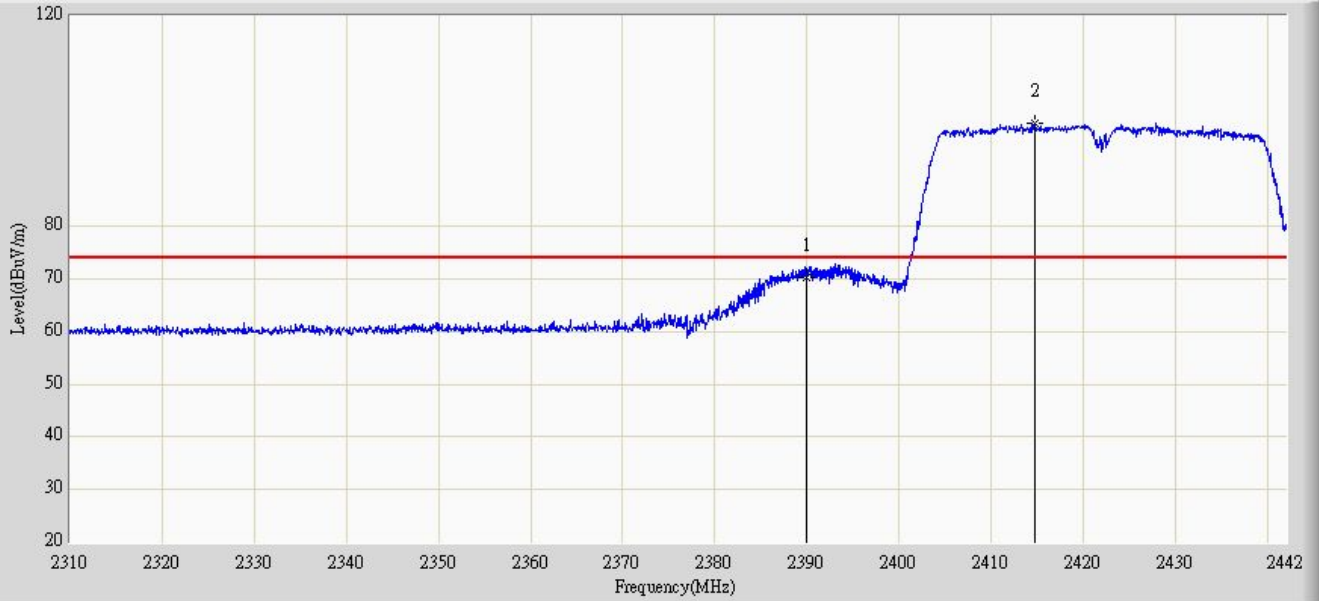

No	Flag	Mark	Frequency (MHz)	Measure Level (dBuV/m)	Reading Level (dBuV)	Over Limit (dB)	Limit (dBuV/m)	Factor	Type
1			2390.000	70.244	39.894	-3.756	74.000	30.350	PK
2		*	2414.676	99.600	69.190	N/A	N/A	30.409	PK

Limit: FCC_Part15.209_RE(3m)	Margin: 0
Probe: BBHA 9120D_499(1-18GHz)	Polarity: Vertical
EUT: Tablet	Power: By Battery
Note: Mode 4: Transmit at channel 2422MHz by 802.11n(40)	

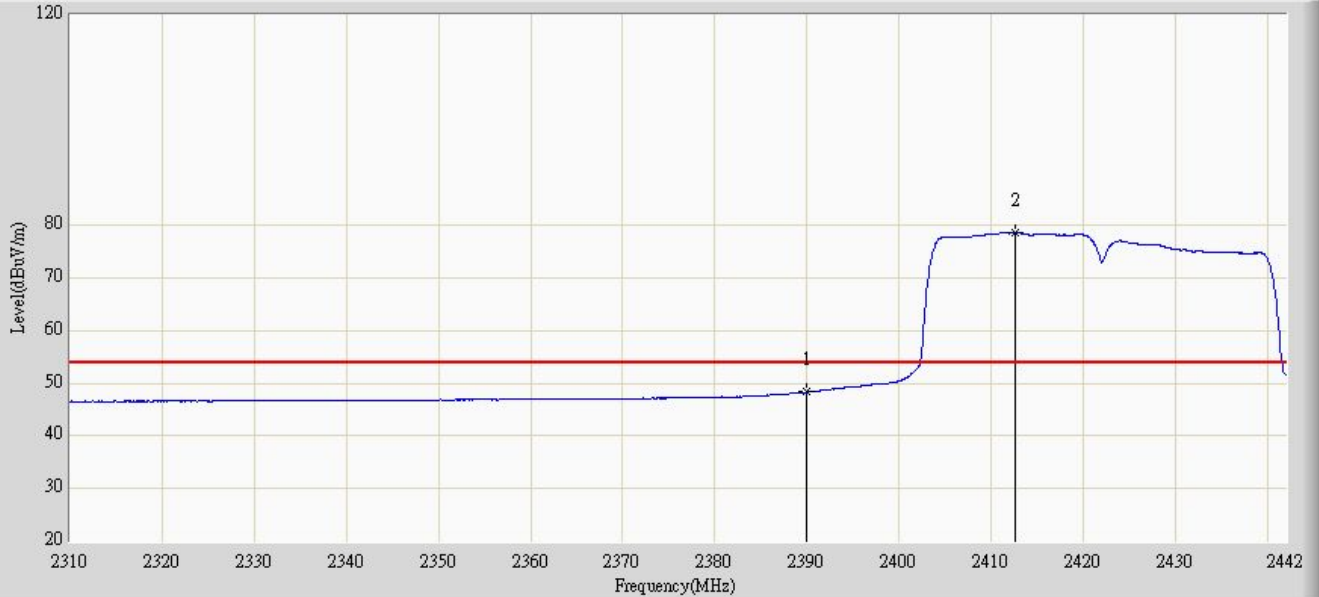

No	Flag	Mark	Frequency (MHz)	Measure Level (dBuV/m)	Reading Level (dBuV)	Over Limit (dB)	Limit (dBuV/m)	Factor	Type
1			2390.000	48.307	17.957	-5.693	54.000	30.350	AV
2		*	2412.564	78.630	48.226	N/A	N/A	30.404	AV

Limit: FCC_Part15.209_RE(3m)	Margin: 0
Probe: BBHA 9120D_499(1-18GHz)	Polarity: Horizontal
EUT: Tablet	Power: By Battery
Note: Mode 4: Transmit at channel 2452MHz by 802.11n(40)	

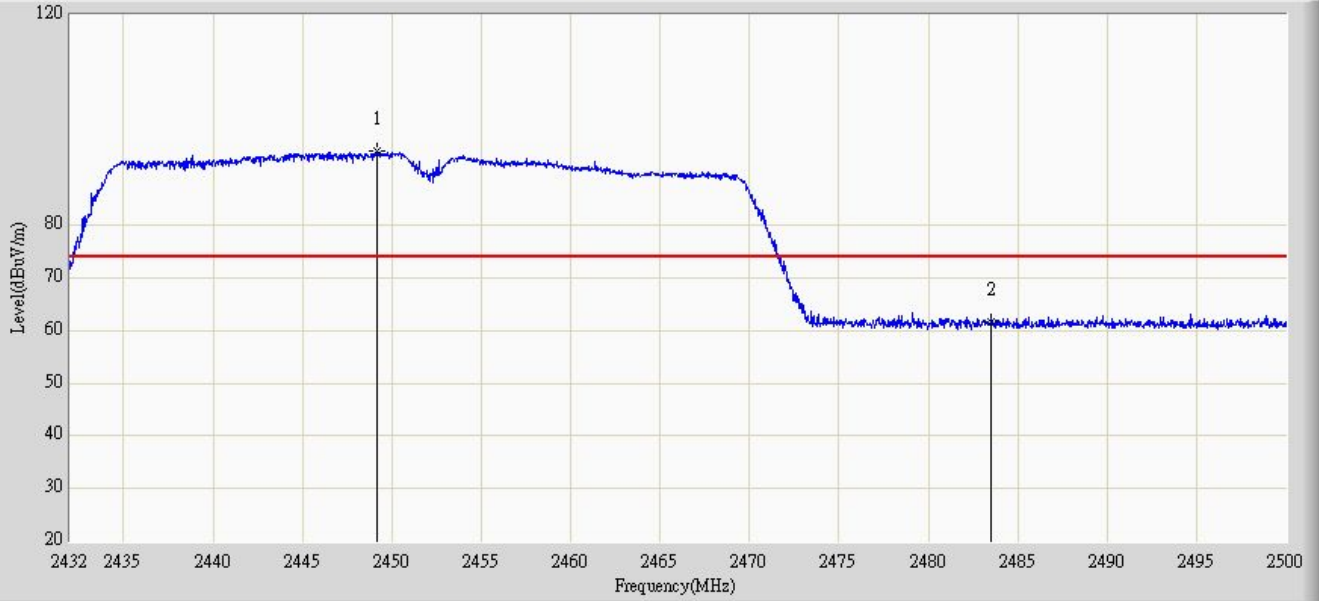

No	Flag	Mark	Frequency (MHz)	Measure Level (dBuV/m)	Reading Level (dBuV)	Over Limit (dB)	Limit (dBuV/m)	Factor	Type
1		*	2449.136	94.126	63.628	N/A	N/A	30.498	PK
2			2483.500	61.675	31.083	-12.325	74.000	30.592	PK

Limit: FCC_Part15.209_RE(3m)	Margin: 0
Probe: BBHA 9120D_499(1-18GHz)	Polarity: Horizontal
EUT: Tablet	Power: By Battery
Note: Mode 4: Transmit at channel 2452MHz by 802.11n(40)	

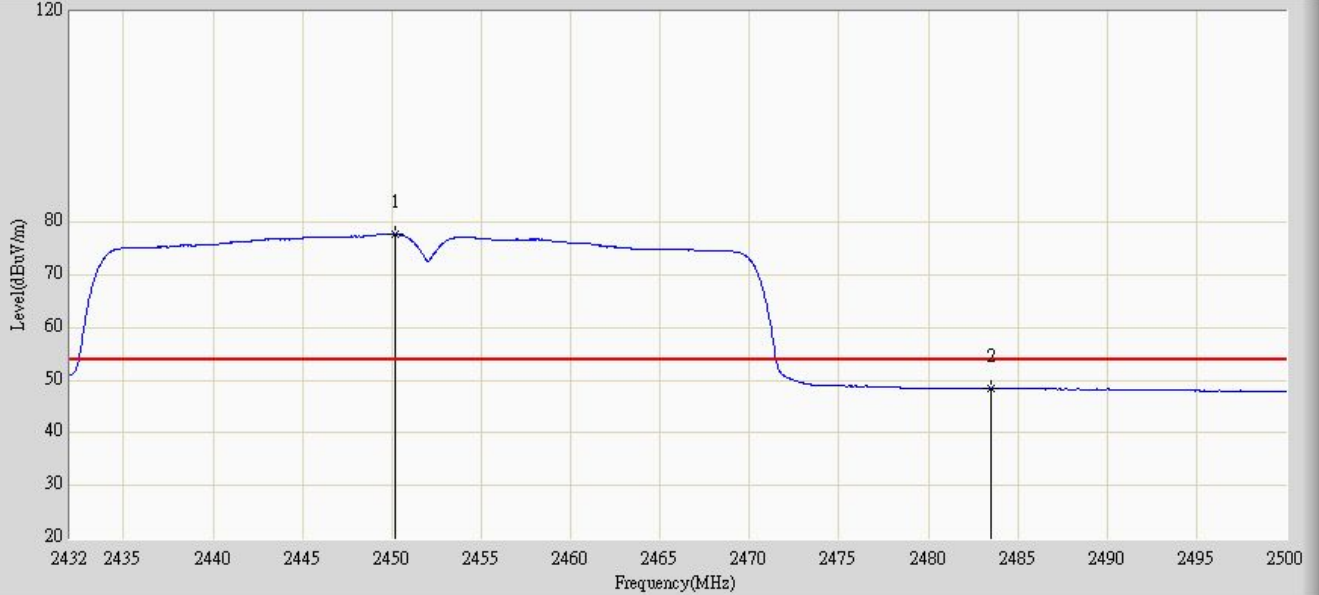

No	Flag	Mark	Frequency (MHz)	Measure Level (dBuV/m)	Reading Level (dBuV)	Over Limit (dB)	Limit (dBuV/m)	Factor	Type
1		*	2450.156	77.748	47.247	N/A	N/A	30.500	AV
2			2483.500	48.473	17.881	-5.527	54.000	30.592	AV

Limit: FCC_Part15.209_RE(3m)	Margin: 0
Probe: BBHA 9120D_499(1-18GHz)	Polarity: Vertical
EUT: Tablet	Power: By Battery
Note: Mode 4: Transmit at channel 2452MHz by 802.11n(40)	

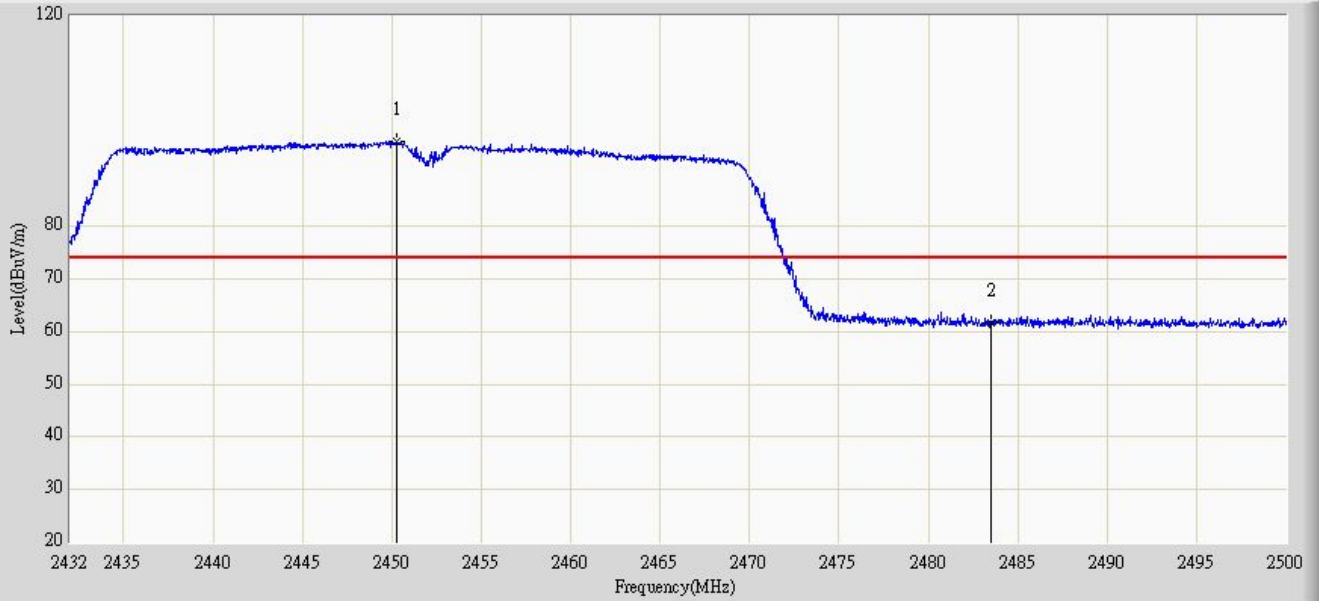

No	Flag	Mark	Frequency (MHz)	Measure Level (dBuV/m)	Reading Level (dBuV)	Over Limit (dB)	Limit (dBuV/m)	Factor	Type
1		*	2450.258	96.040	65.539	N/A	N/A	30.502	PK
2			2483.500	61.620	31.028	-12.380	74.000	30.592	PK

Limit: FCC_Part15.209_RE(3m)	Margin: 0
Probe: BBHA 9120D_499(1-18GHz)	Polarity: Vertical
EUT: Tablet	Power: By Battery
Note: Mode 4: Transmit at channel 2452MHz by 802.11n(40)	

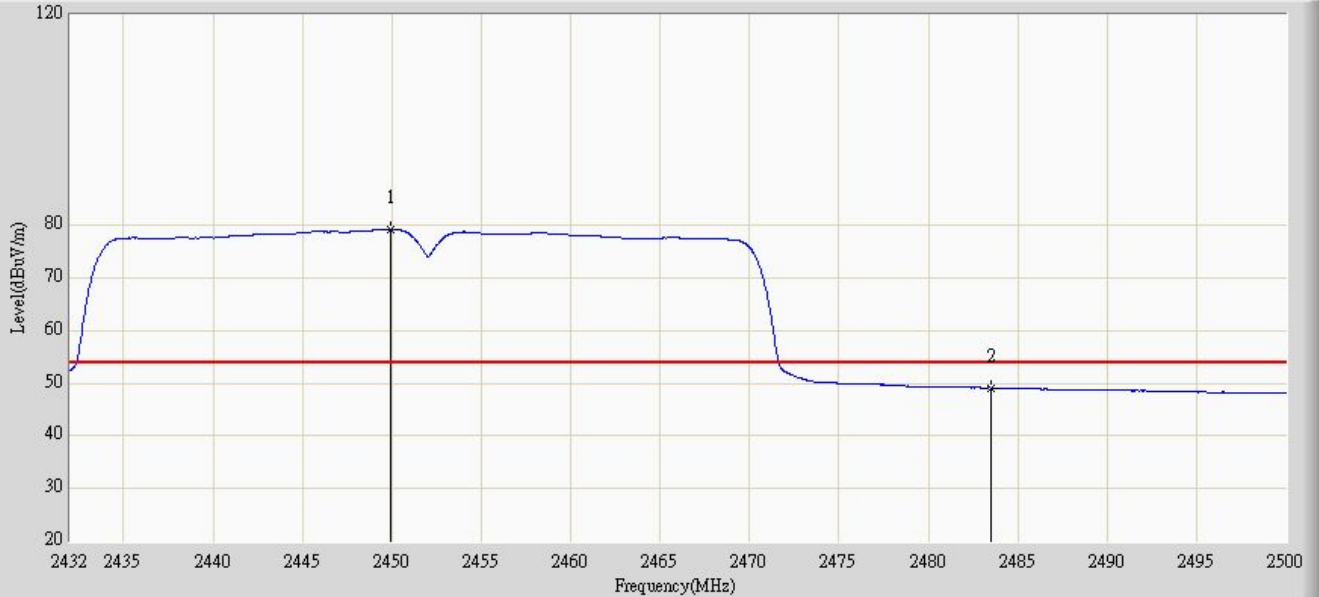

No	Flag	Mark	Frequency (MHz)	Measure Level (dBuV/m)	Reading Level (dBuV)	Over Limit (dB)	Limit (dBuV/m)	Factor	Type
1		*	2449.952	79.247	48.747	N/A	N/A	30.500	AV
2			2483.500	49.149	18.557	-4.851	54.000	30.592	AV

4.6. Power Spectral Density Measurement

TEST CONFIGURATION



TEST PROCEDURE

The EUT was tested according to KDB558074 D01 v03r01 for compliance to FCC 47CFR 15.247 requirements. Set RBW= 3 kHz, VBW ≥ 10KHz, SPAN to 1.5 times greater than the EBW,.

LIMIT

For digitally modulated systems, the power spectral density conducted from the intentional radiator to the antenna shall not be greater than 8 dBm in any 3 kHz band during any time interval of continuous transmission.

TEST RESULTS

Product	:	HS-7DTB26-4GB
Test Item	:	Power Spectral Density
Test Mode	:	Mode 1: Transmit by 802.11b

Channel No.	Frequency (MHz)	Measurement PSD (dBm/3KHz)	Limit (dBm/3KHz)	Result
01	2412	-16.49	8	Pass
06	2437	-15.46	8	Pass
11	2462	-14.70	8	Pass

Channel 01 (2412MHz)

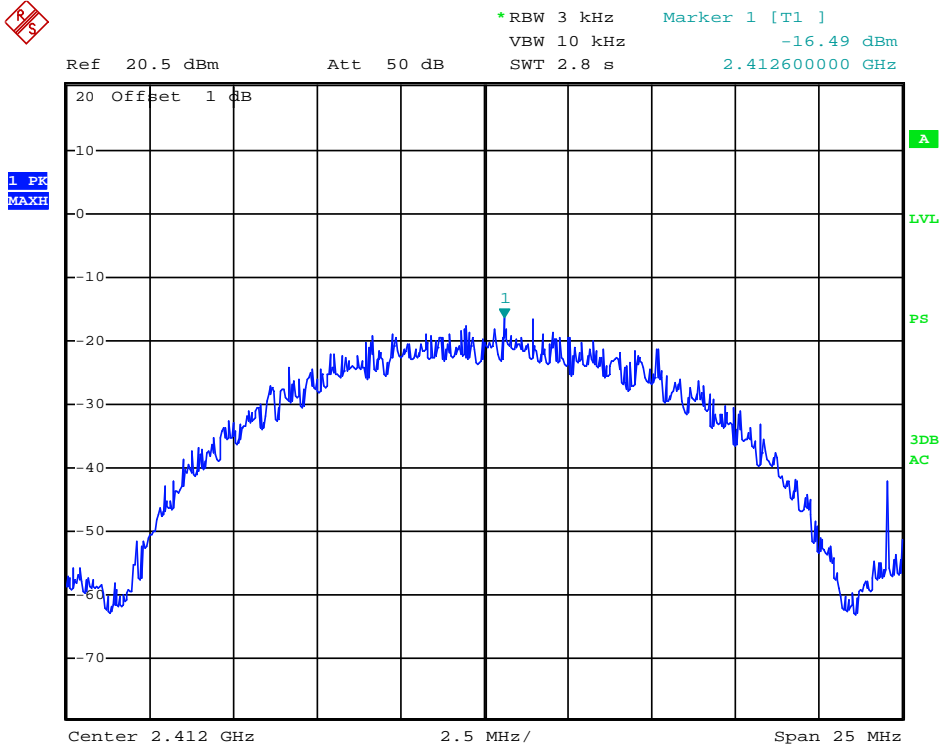

Date: 17.JAN.2014 15:35:45

Channel 06 (2437MHz)

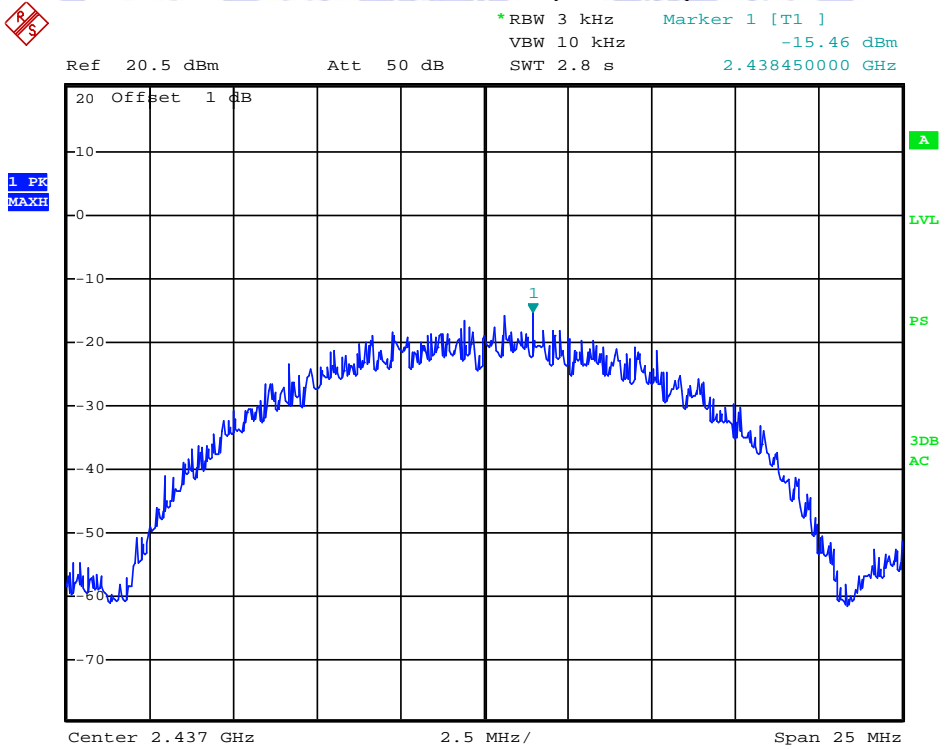

Date: 17.JAN.2014 15:36:58

Channel 11 (2462MHz)

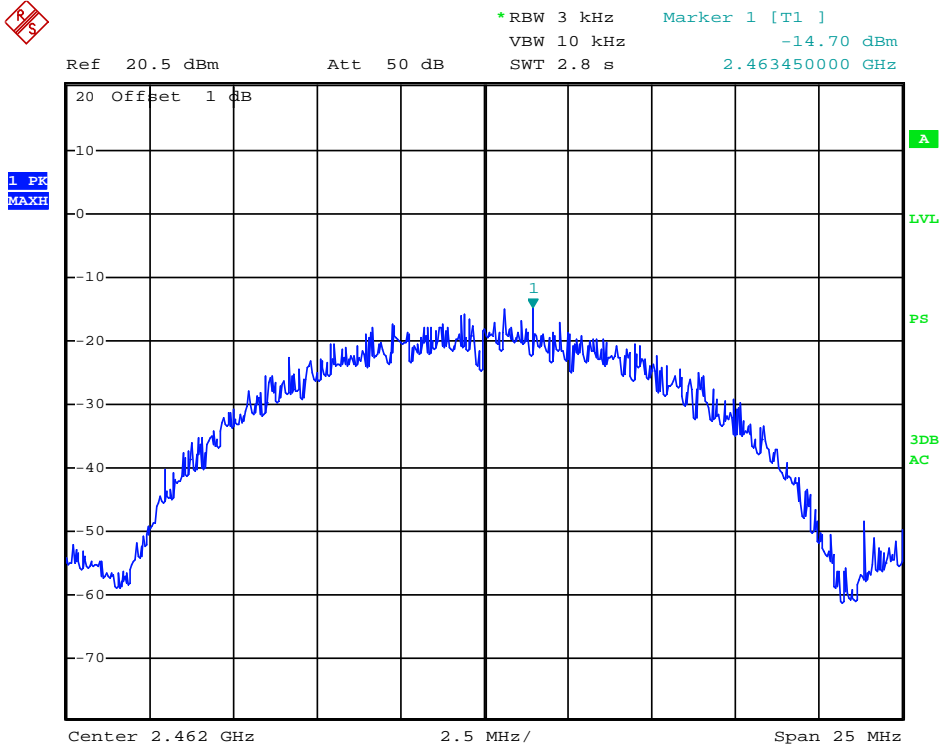

Date: 17.JAN.2014 15:37:22



Product	:	HS-7DTB26-4GB
Test Item	:	Power Spectral Density
Test Mode	:	Mode 2: Transmit by 802.11g

Channel No.	Frequency (MHz)	Measurement PSD (dBm/3KHz)	Limit (dBm/3KHz)	Result
01	2412	-24.96	8	Pass
06	2437	-23.65	8	Pass
11	2462	-22.57	8	Pass

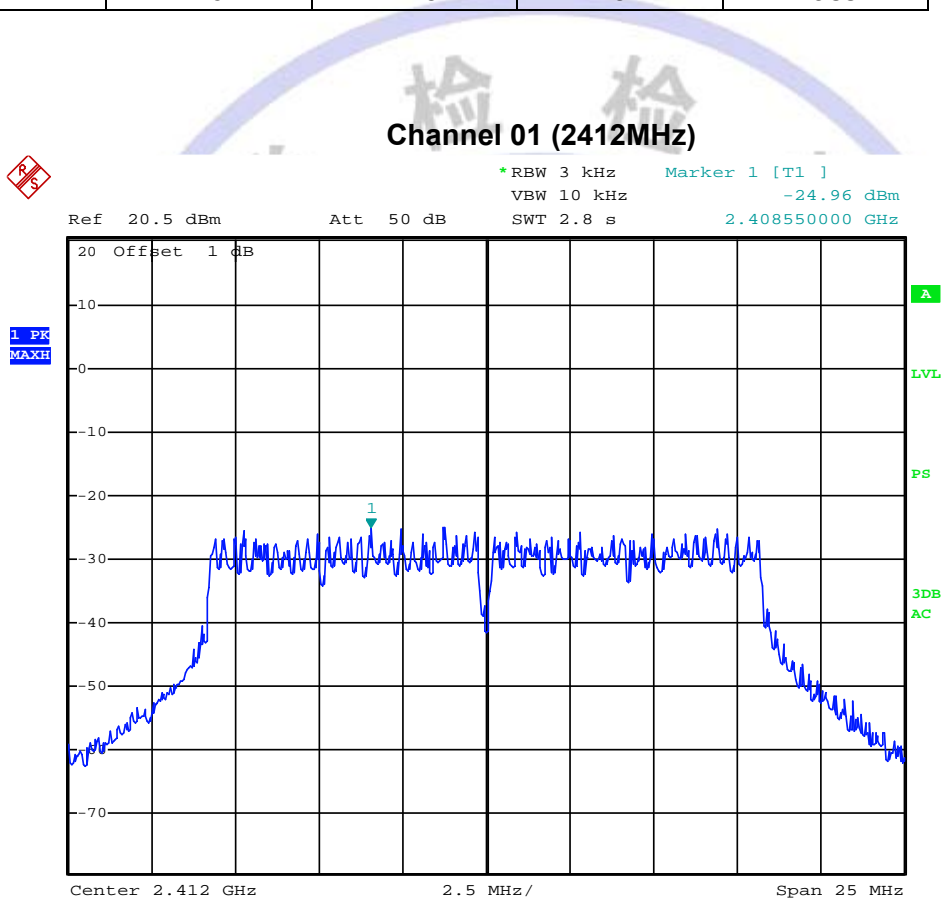

Date: 17.JAN.2014 15:35:05

Channel 06 (2437MHz)

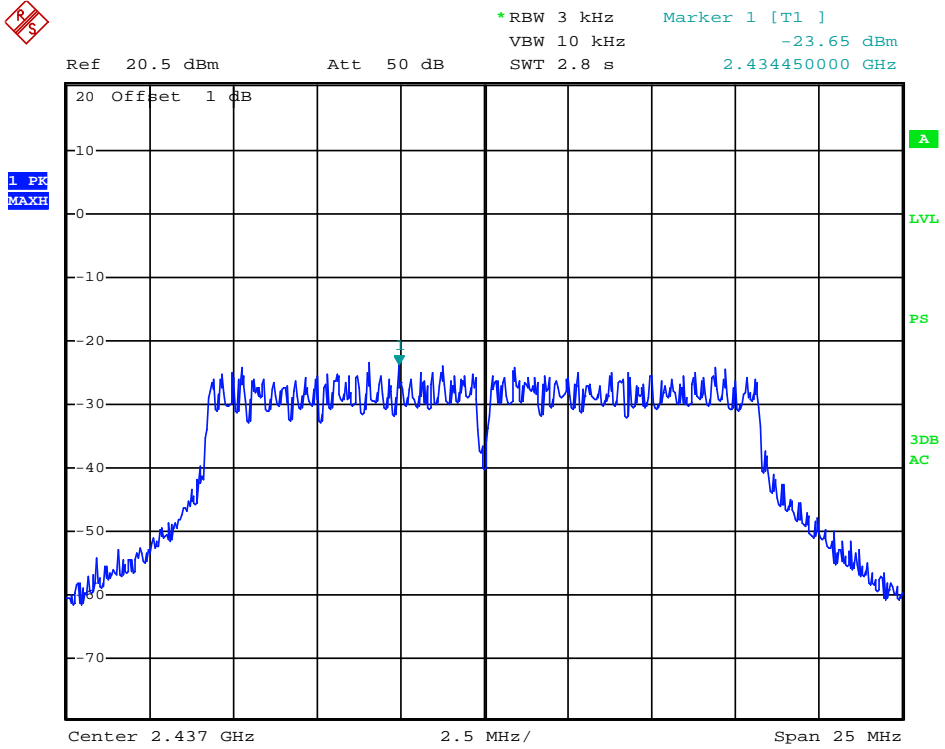

Date: 17.JAN.2014 15:34:38



Channel 11 (2462MHz)

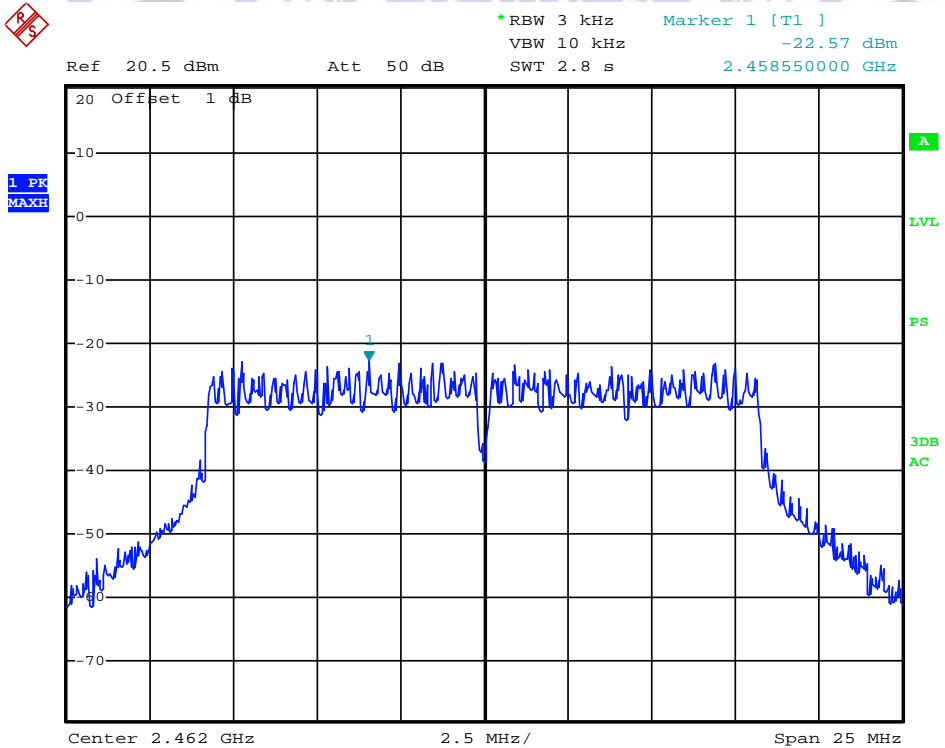

Date: 17.JAN.2014 15:33:56

Product	:	HS-7DTB26-4GB
Test Item	:	Power Spectral Density
Test Mode	:	Mode 3: Transmit by 802.11n (20MHz)

Channel No.	Frequency (MHz)	Measurement PSD (dBm/3KHz)	Limit (dBm/3KHz)	Result
01	2412	-23.63	8	Pass
06	2437	-22.87	8	Pass
11	2462	-21.33	8	Pass

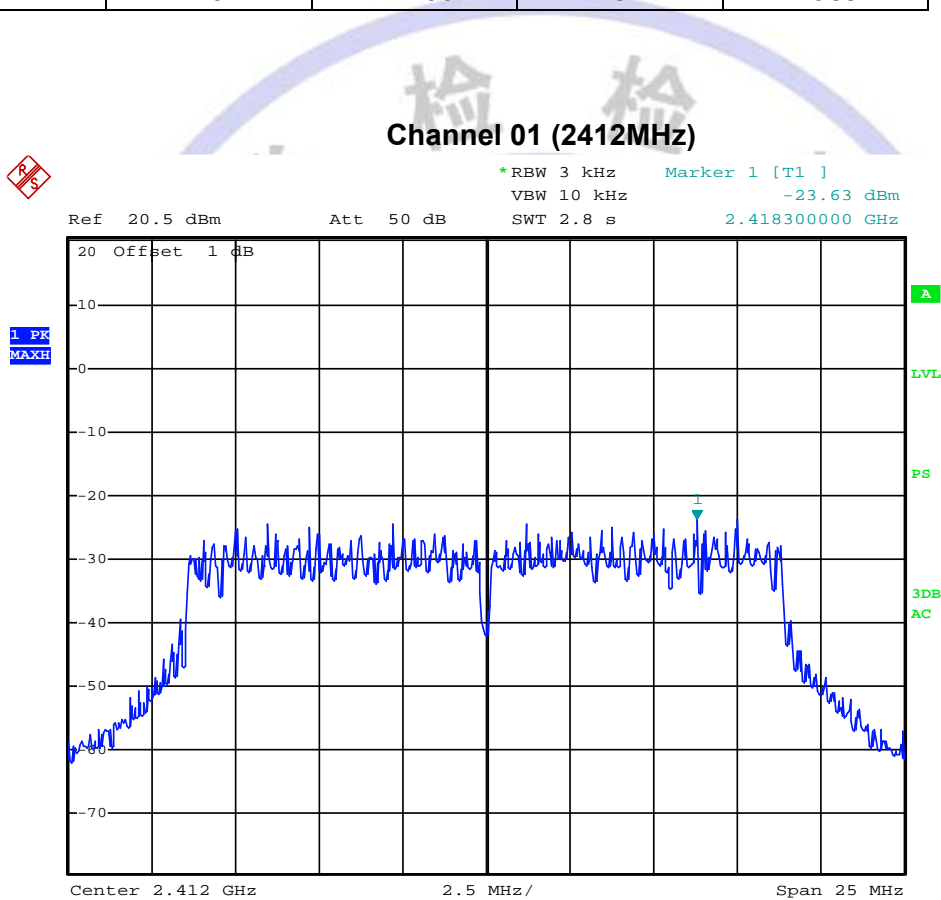

Date: 17.JAN.2014 15:32:31

Channel 06 (2437MHz)

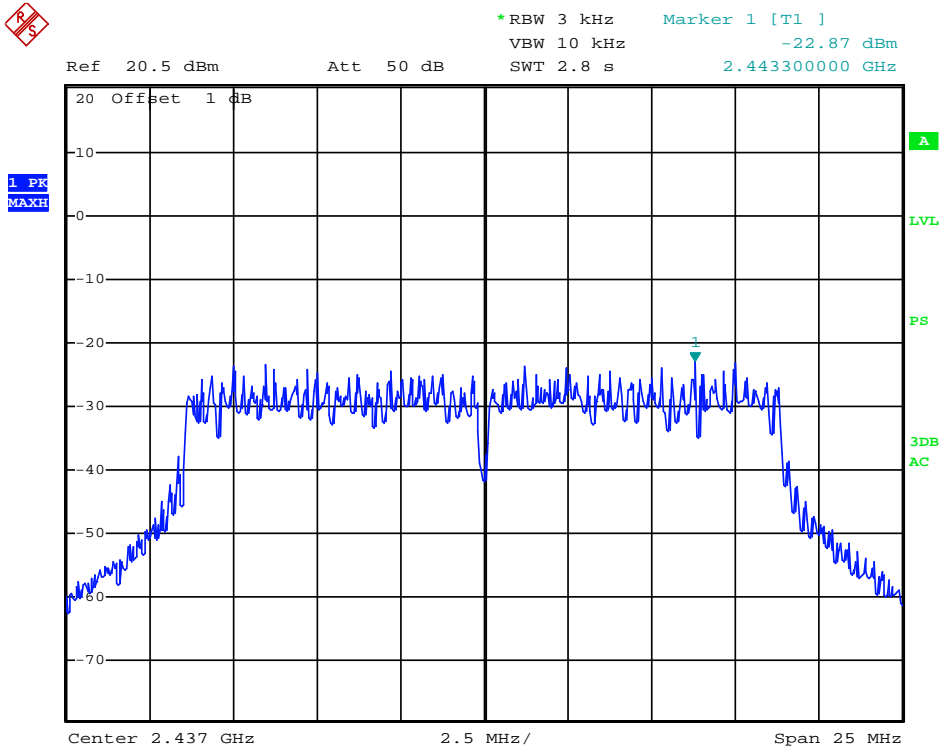

Date: 17.JAN.2014 15:32:55



Channel 11 (2462MHz)

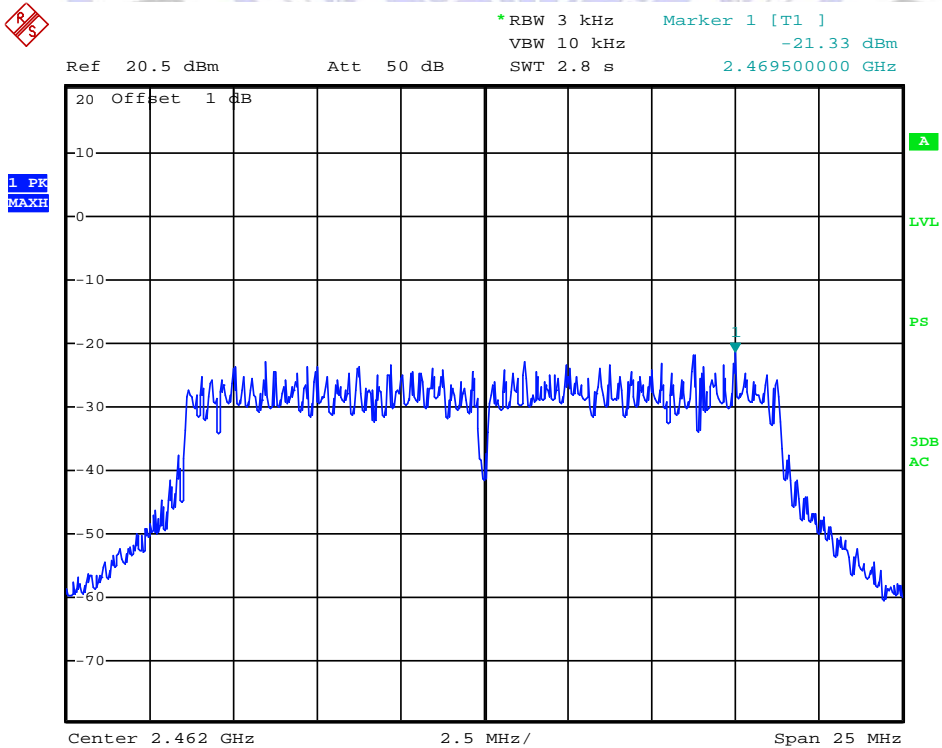

Date: 17.JAN.2014 15:33:21

Product	:	HS-7DTB26-4GB
Test Item	:	Power Spectral Density
Test Mode	:	Mode 4: Transmit by 802.11n (40MHz)

Channel No.	Frequency (MHz)	Measurement PSD (dBm/3KHz)	Limit (dBm/3KHz)	Result
03	2422	-25.87	8	Pass
06	2437	-26.11	8	Pass
09	2452	-25.23	8	Pass

Channel 03 (2422MHz)

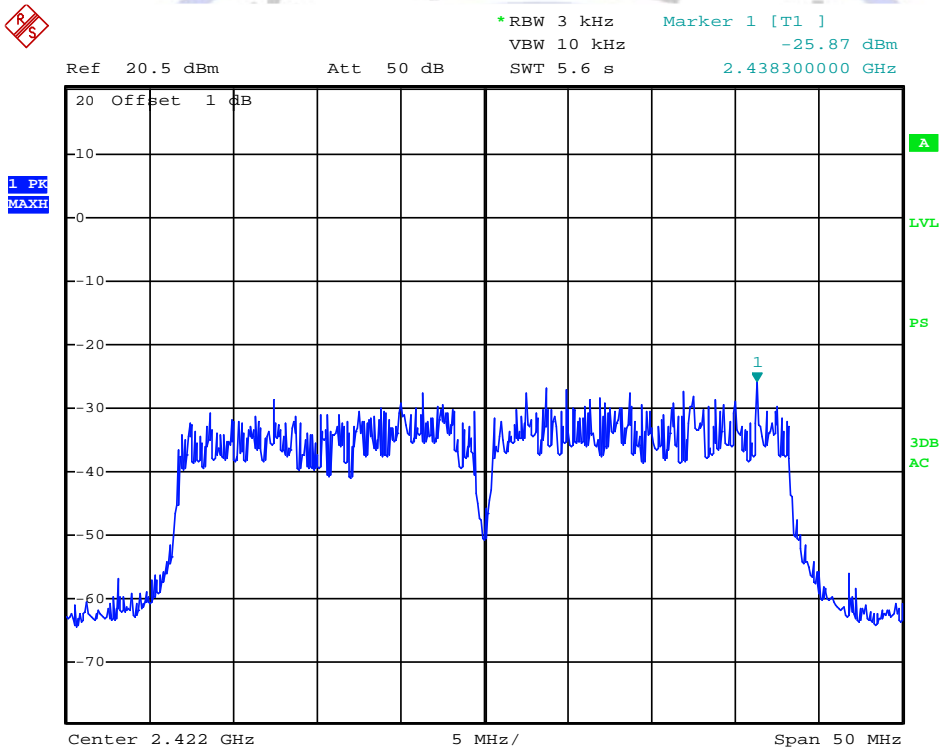

Date: 17.JAN.2014 15:31:51

Channel 06 (2437MHz)

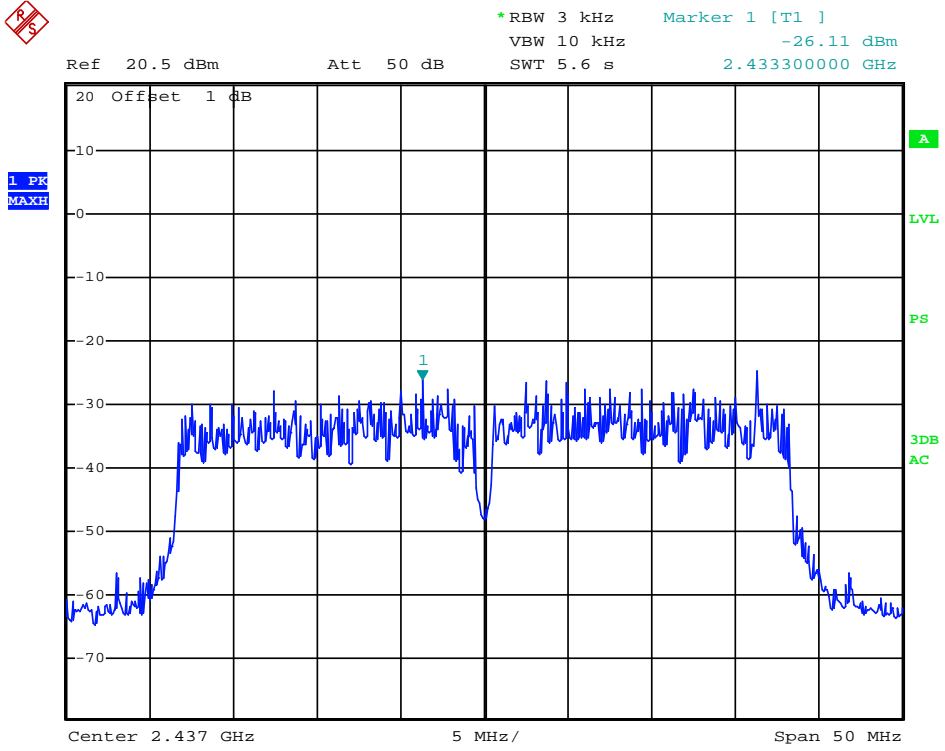

Date: 17.JAN.2014 15:31:19



Channel 09 (2452MHz)

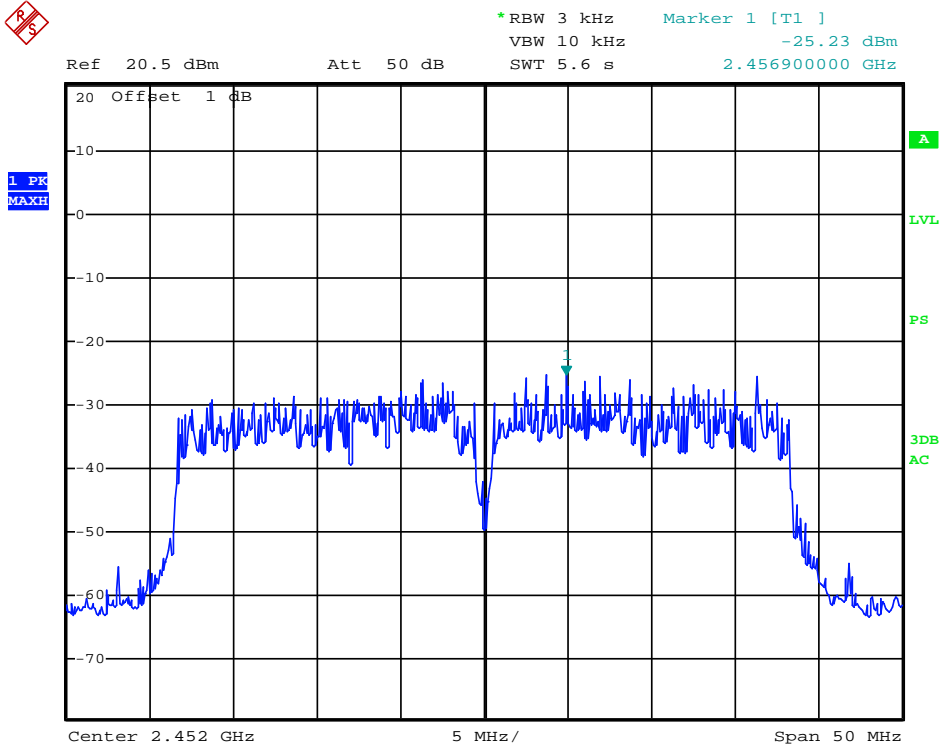

Date: 17.JAN.2014 15:30:41

4.7. Spurious RF Conducted Emission

TEST CONFIGURATION

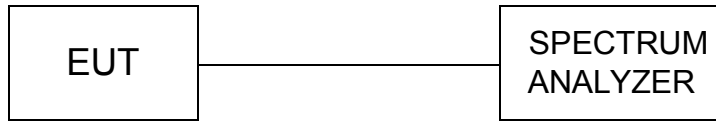

TEST PROCEDURE

The EUT was tested according to KDB558074 D01 v03r01 for compliance to FCC 47CFR 15.247 requirements.

The Spurious RF conducted emissions compliance of RF radiated emission should be measured by following the guidance in ANSI C63.10-2009 with respect to maximizing the emission by rotating the EUT, measuring the emission while the EUT is situated in three orthogonal planes (if appropriate), adjusting the measurement antenna height and polarization etc. Set RBW=100kHz and VBM= 300kHz to measure the peak field strength , and measure frequency range from 30MHz to 26.5GHz.

LIMIT

In any 100 kHz bandwidth outside the frequency band in which the spread spectrum or digitally modulated intentional radiator is operating, the radio frequency power that is produced by the intentional radiator shall be at least 20 dB below that in the 100 kHz bandwidth within the band that contains the highest level of the desired power, based on either an RF conducted or a radiated measurement, provided the transmitter demonstrates compliance with the peak conducted power limits.

TEST RESULTS

Product	:	HS-7DTB26-4GB
Test Item	:	RF Antenna Conducted Spurious
Test Mode	:	Mode 1: Transmit by 802.11b

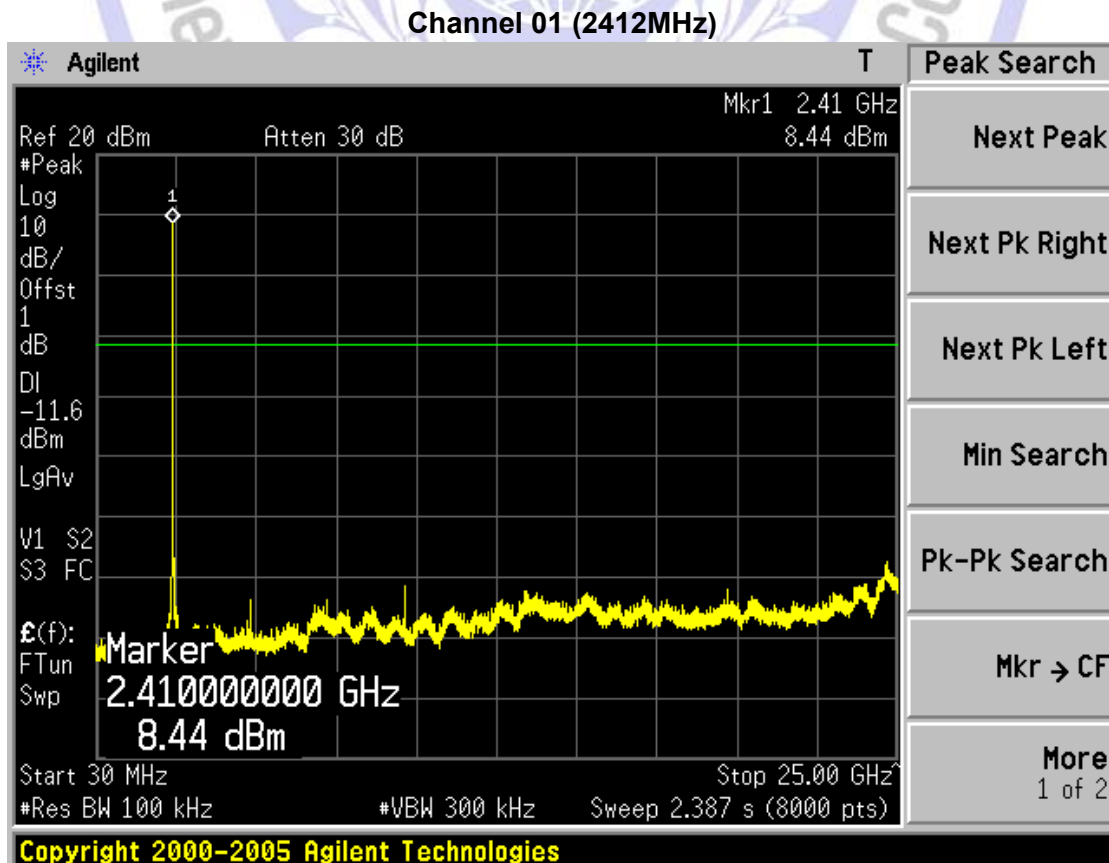

Channel 06 (2437MHz)

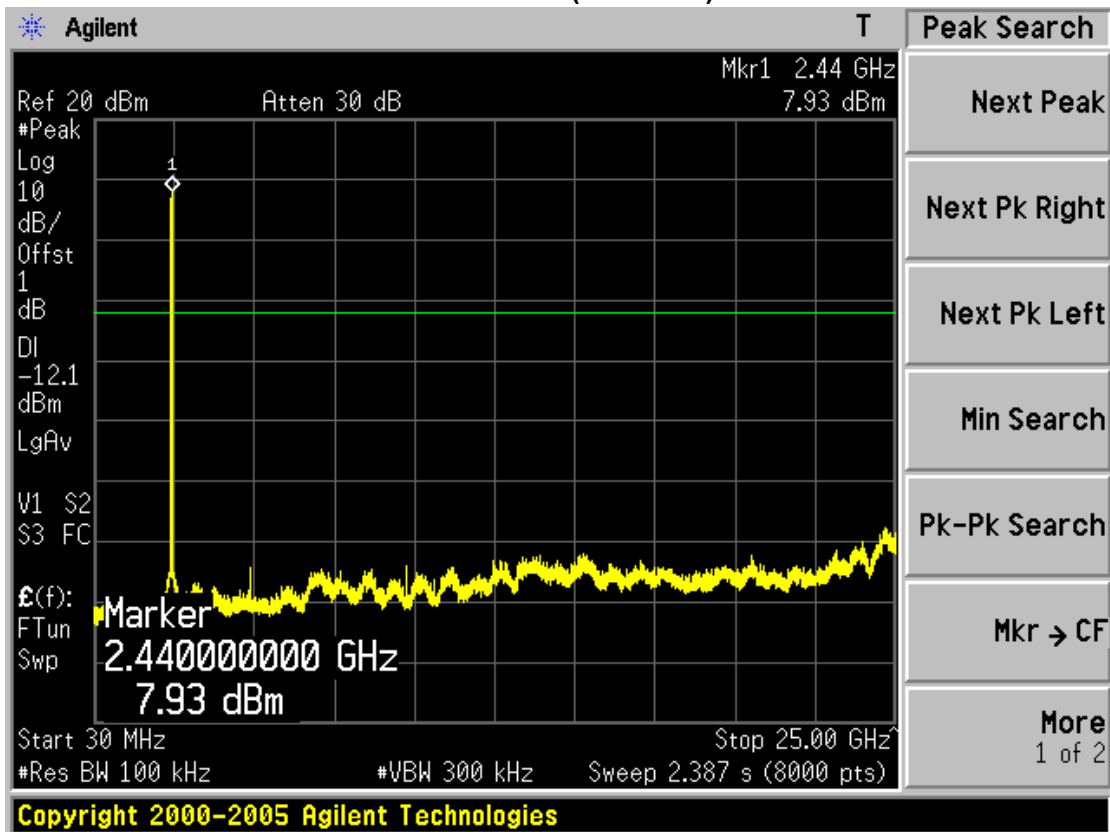

Channel 11 (2462MHz)

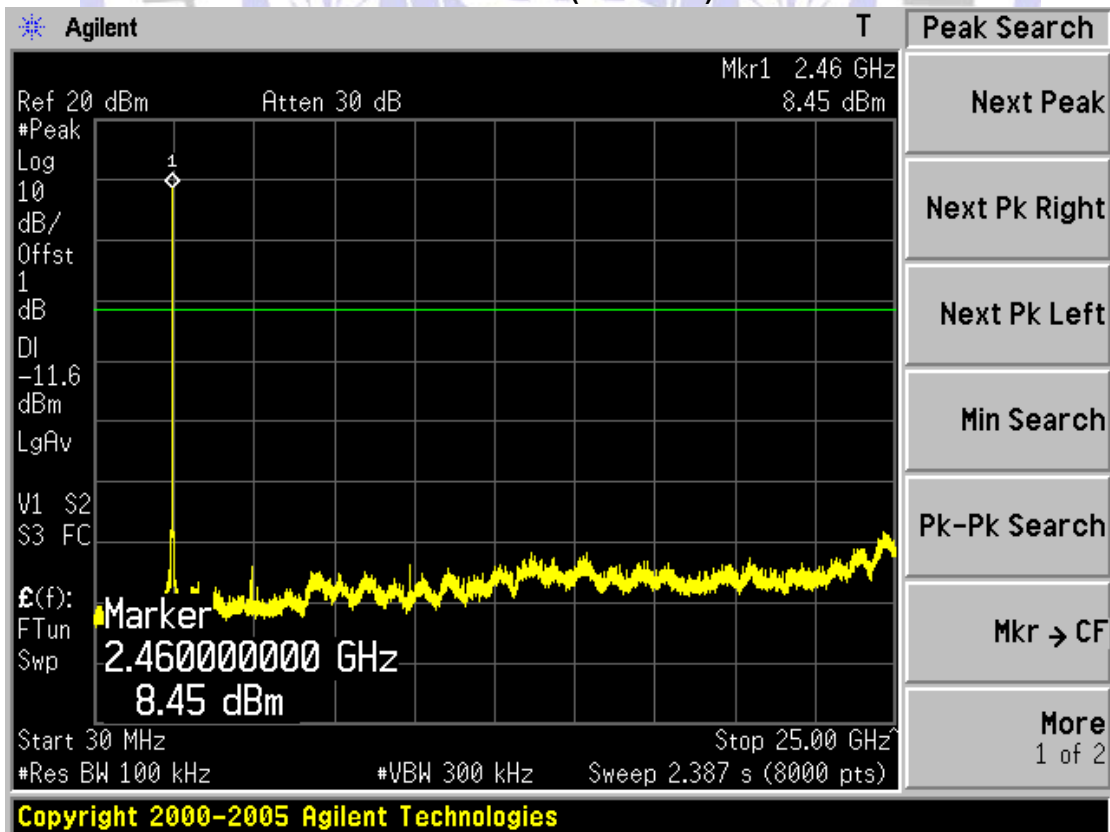

Product	:	HS-7DTB26-4GB
Test Item	:	RF Antenna Conducted Spurious
Test Mode	:	Mode 2: Transmit by 802.11g

Channel 01 (2412MHz)

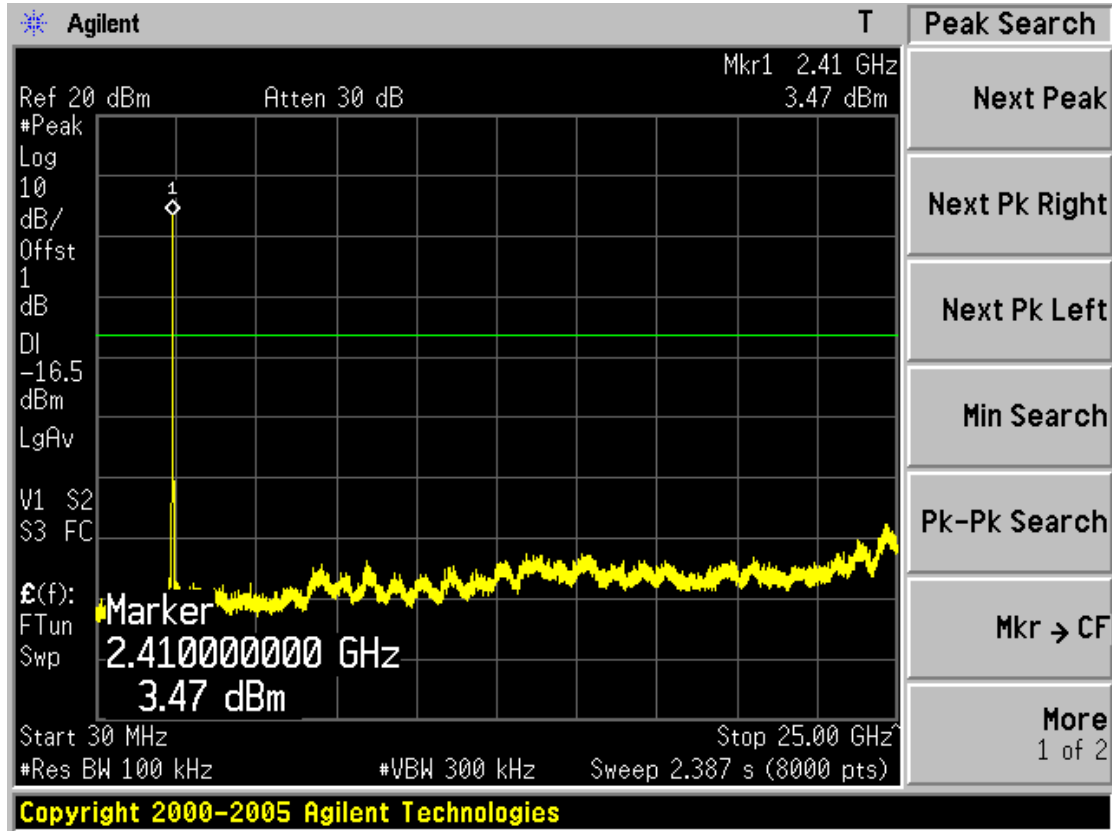

Channel 06 (2437MHz)

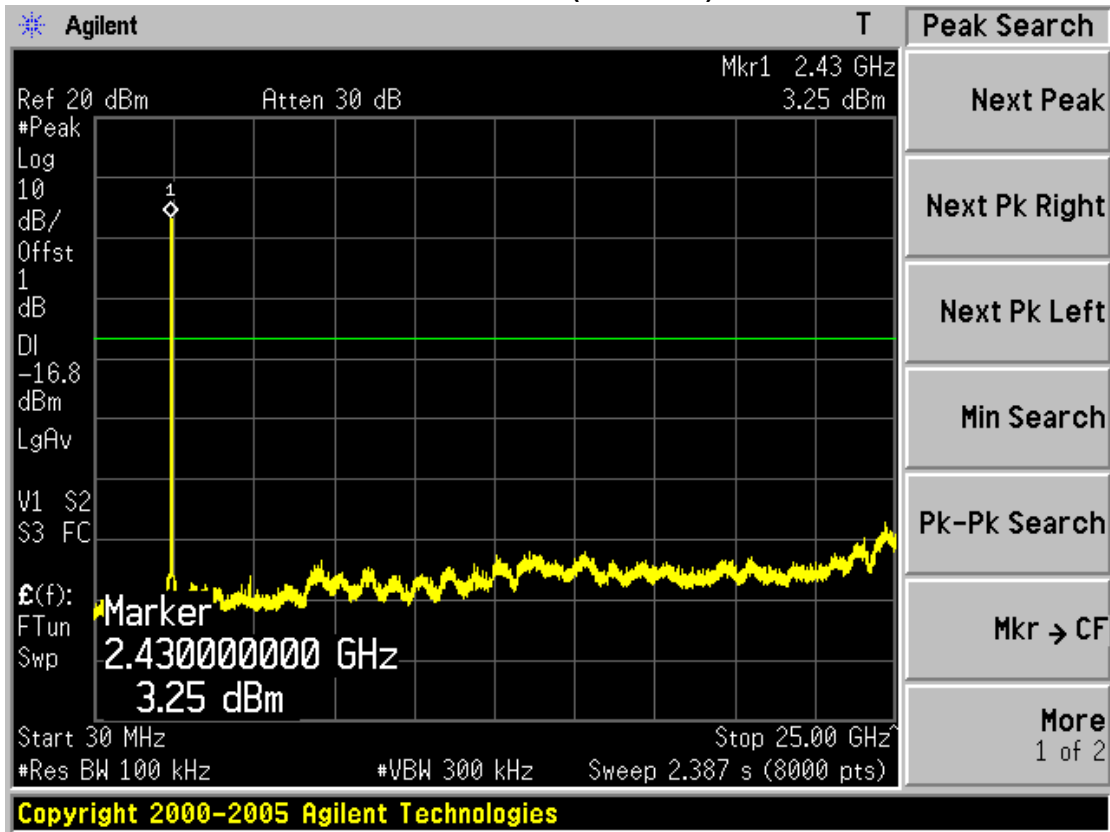

Channel 11 (2462MHz)

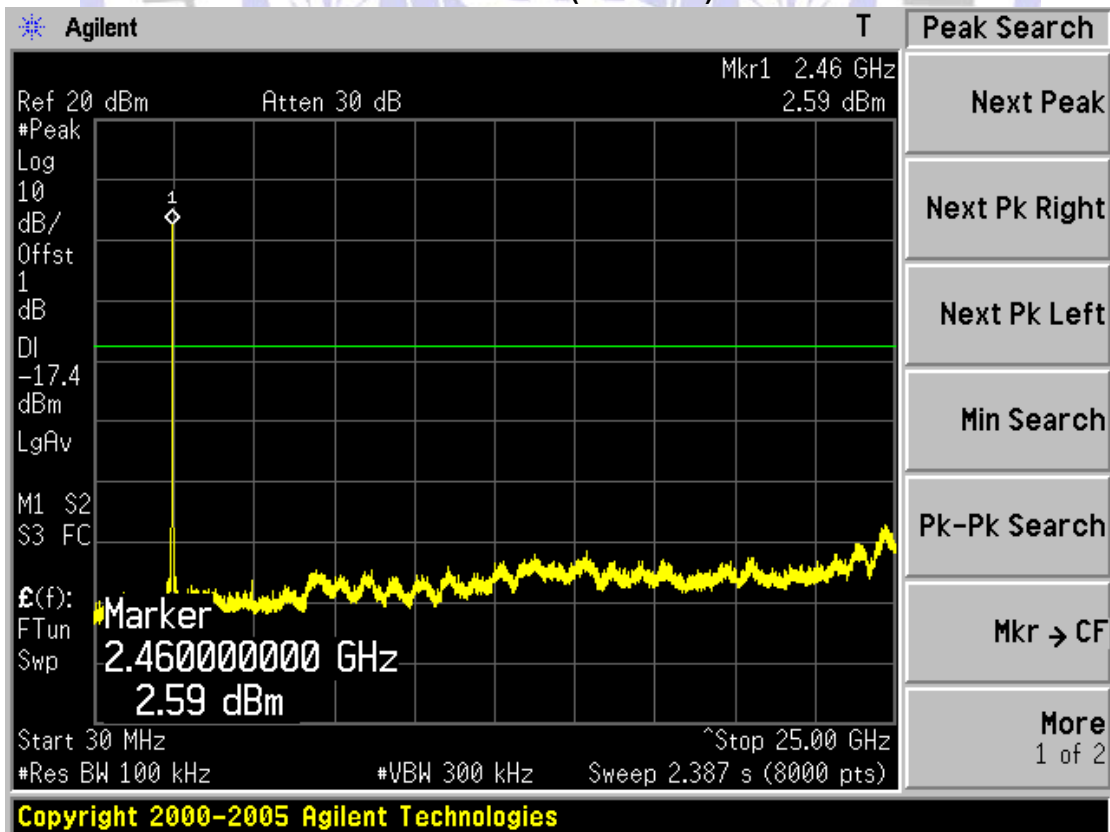

Product	:	HS-7DTB26-4GB
Test Item	:	RF Antenna Conducted Spurious
Test Mode	:	Mode 3: Transmit by 802.11n (20MHz)

Channel 01 (2412MHz)

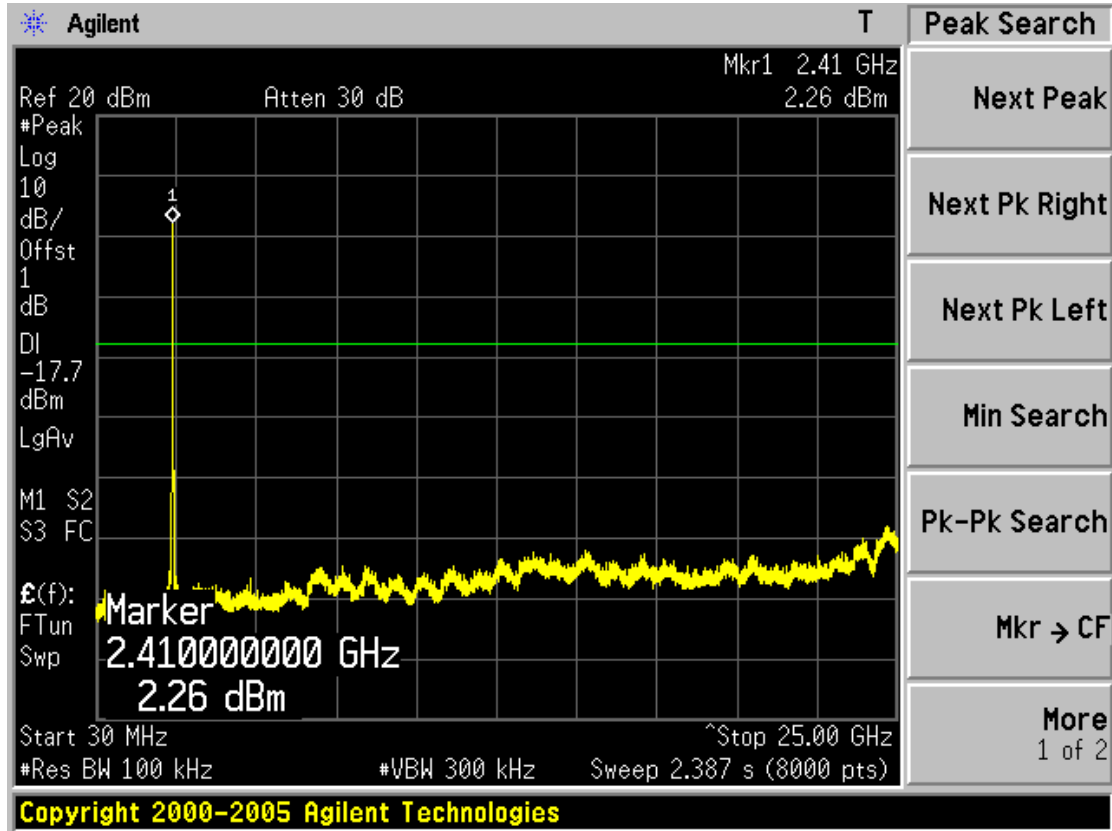

Channel 06 (2437MHz)

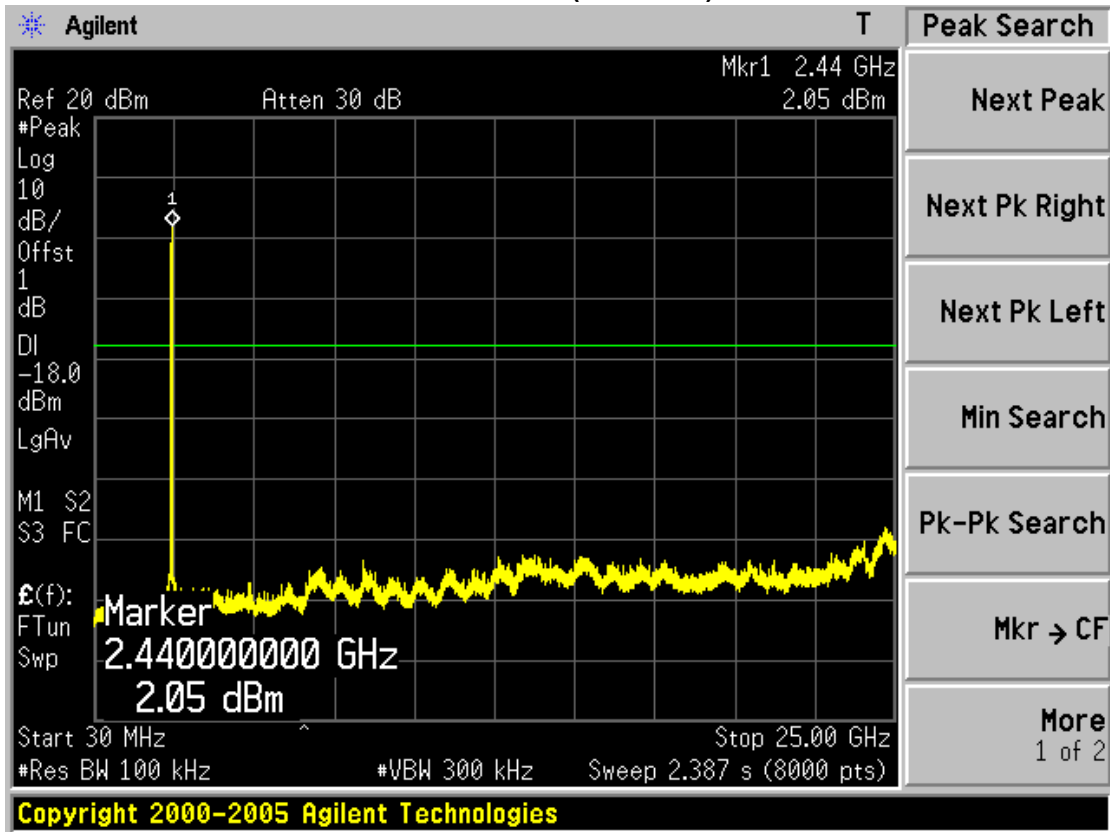

Channel 11 (2462MHz)

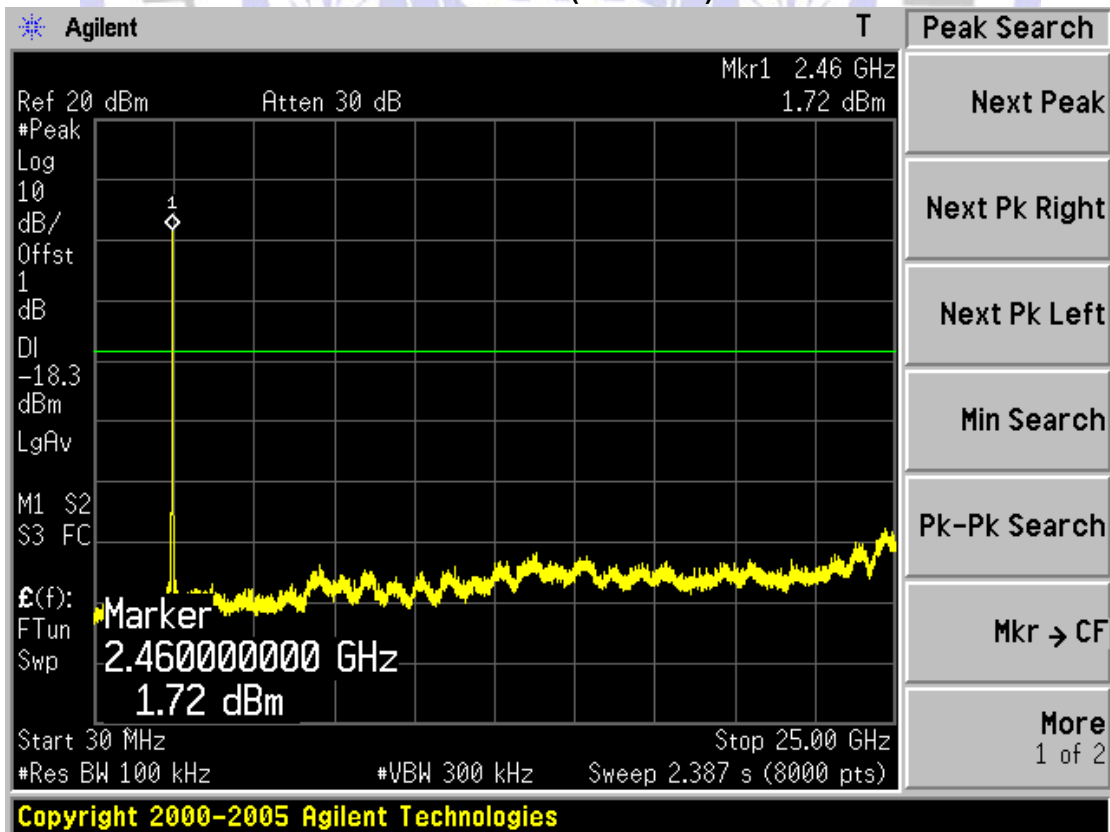

Product	:	HS-7DTB26-4GB
Test Item	:	RF Antenna Conducted Spurious
Test Mode	:	Mode 4: Transmit by 802.11n (40MHz)

Channel 03 (2422MHz)

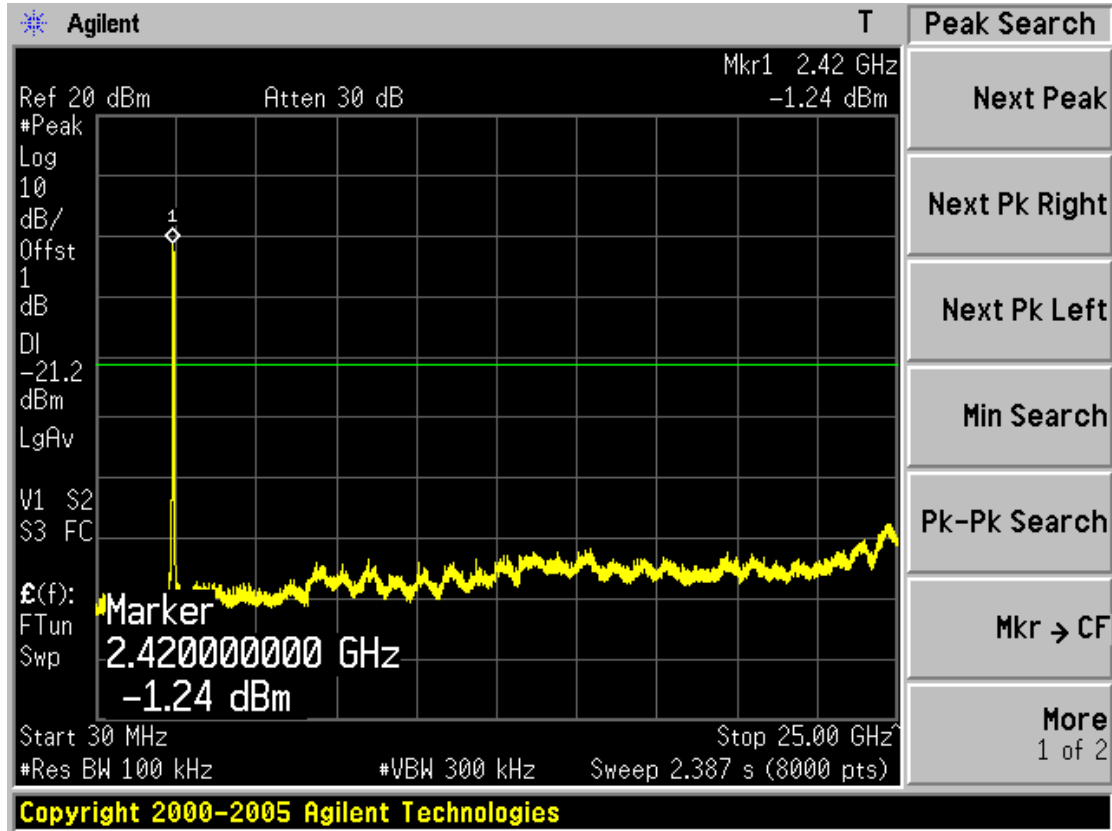

Channel 06 (2437MHz)

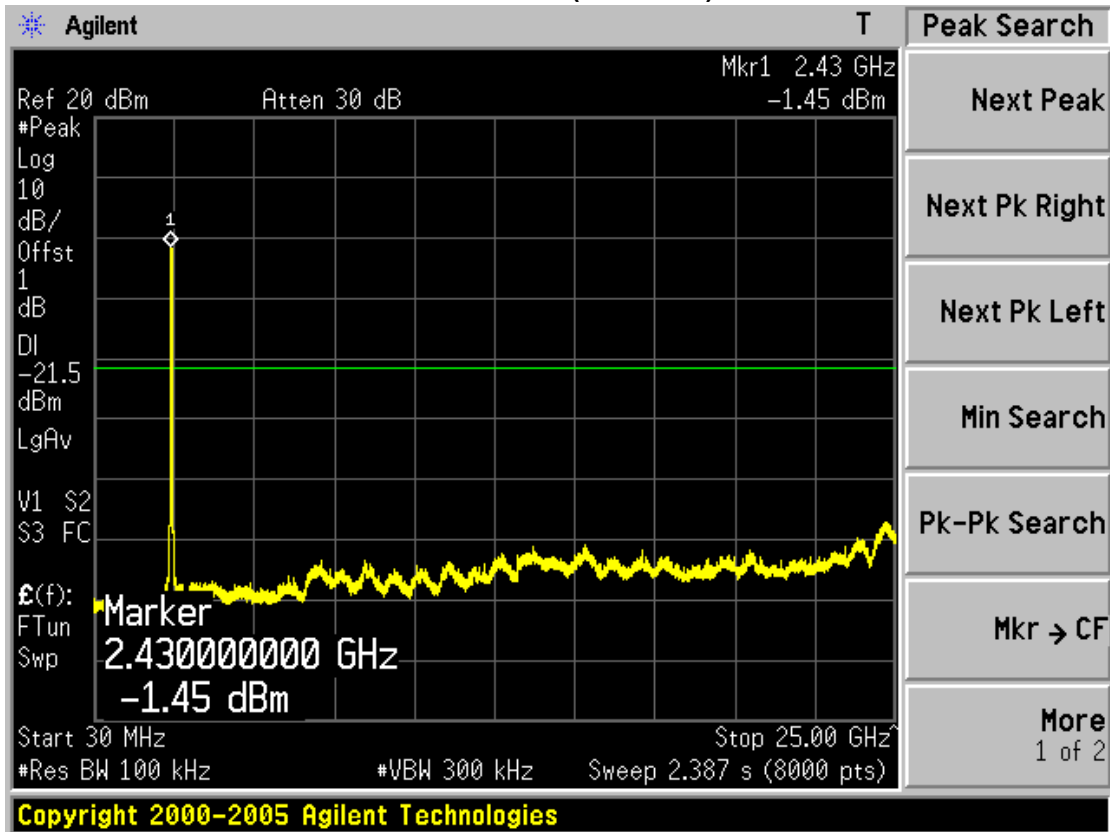

Channel 09 (2452MHz)

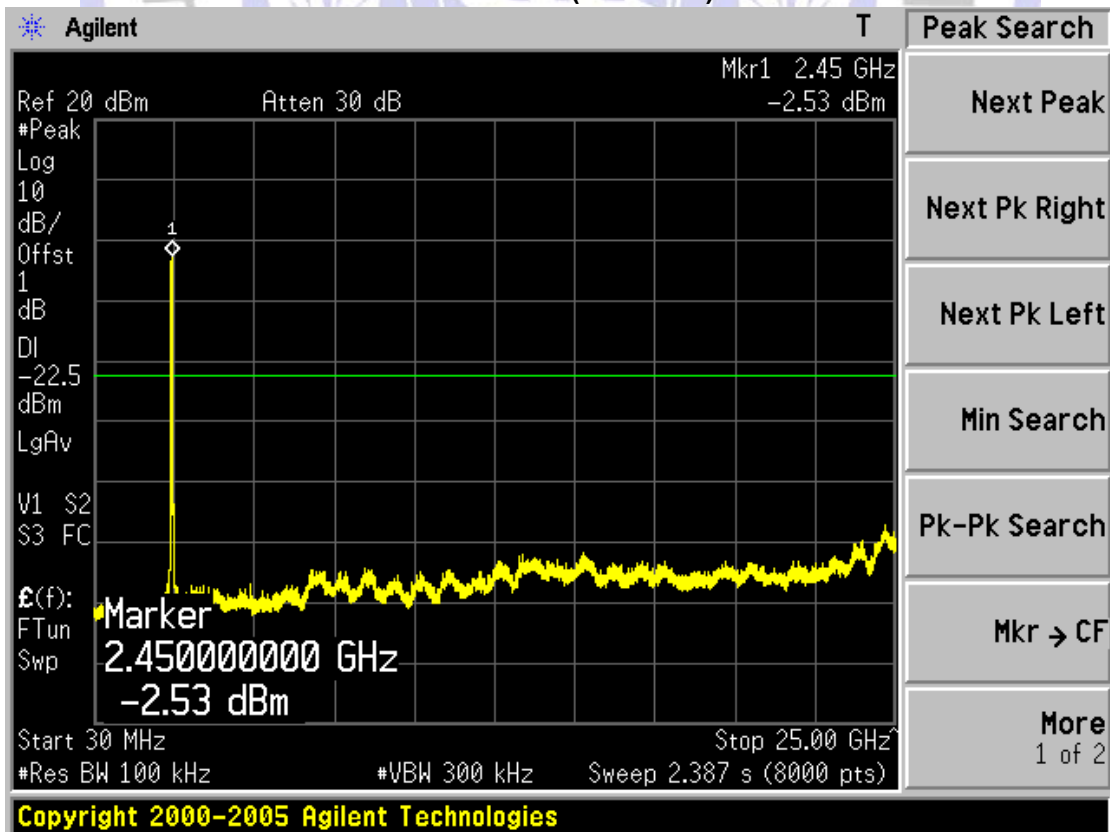

4.8. Operation Frequency Range of 20dB Bandwidth

TEST CONFIGURATION

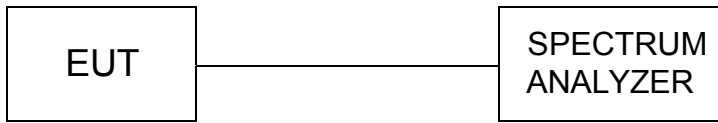

TEST PROCEDURE

The EUT was tested according to KDB558074 D01 v03r01 for compliance to FCC 47CFR 15.247 requirements. Set RBW = 100 kHz, Span greater than RBW.

LIMIT

20 dB bandwidth of the emission is contained within the operation frequency band.

TEST RESULT

Product	: HS-7DTB26-4GB
Test Item	: Operation Frequency Range of 20dB Bandwidth
Test Mode	: Mode 1: Transmit by 802.11b

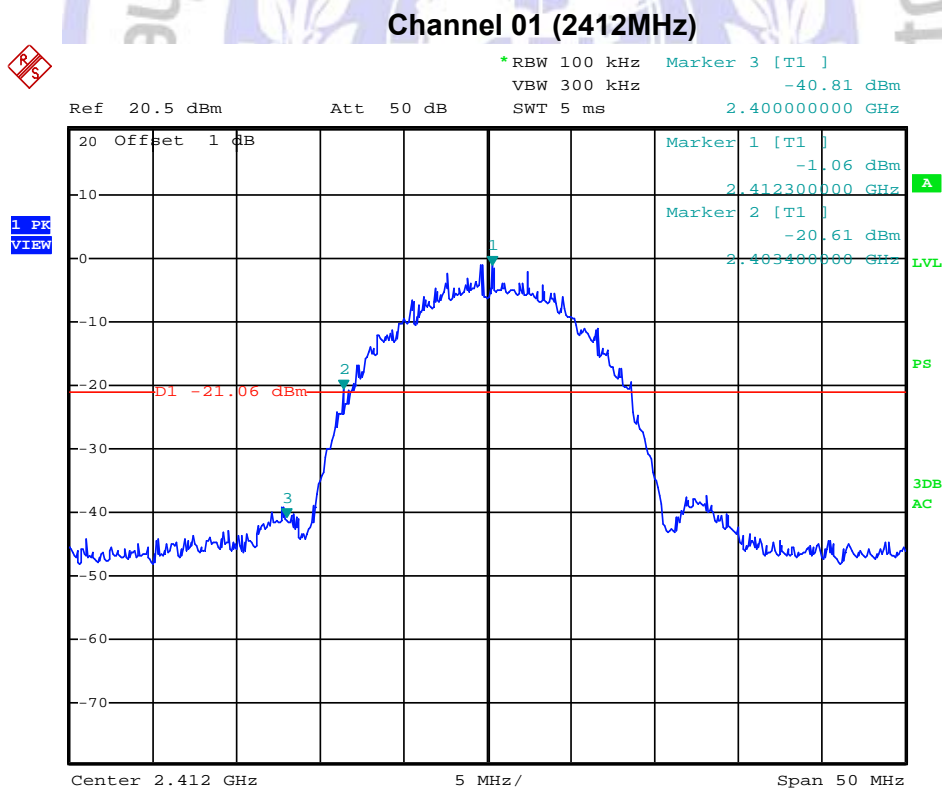

Date: 17.JAN.2014 15:15:46

Channel 11 (2462MHz)

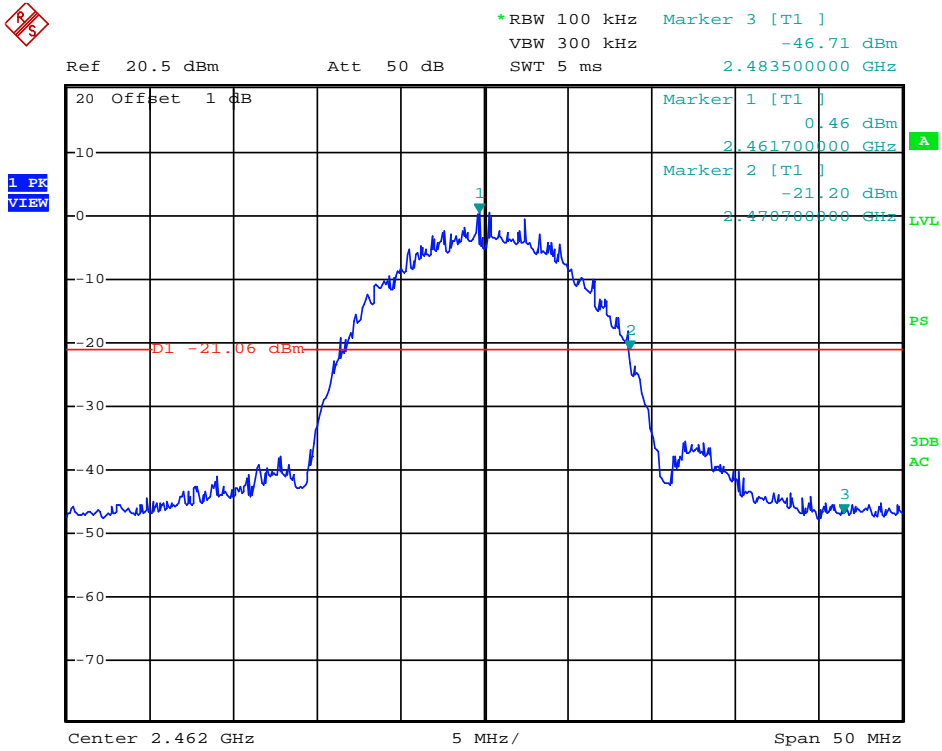

Date: 17.JAN.2014 15:16:35



Product	: HS-7DTB26-4GB
Test Item	: Operation Frequency Range of 20dB Bandwidth
Test Mode	: Mode 2: Transmit by 802.11g

Channel 01 (2412MHz)

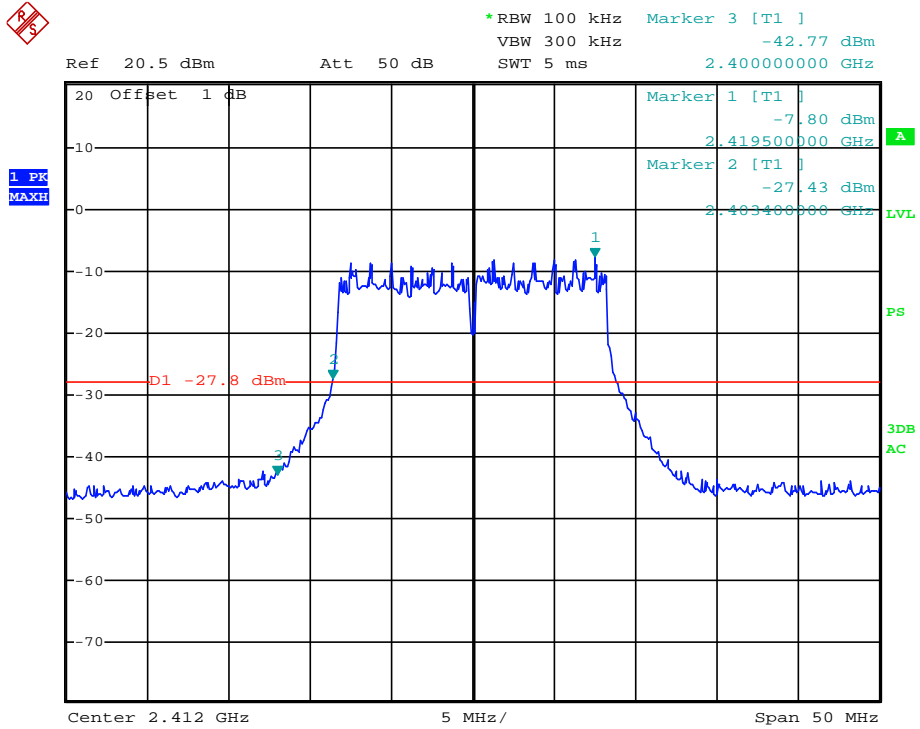

Date: 17.JAN.2014 15:14:22

Channel 11 (2462MHz)

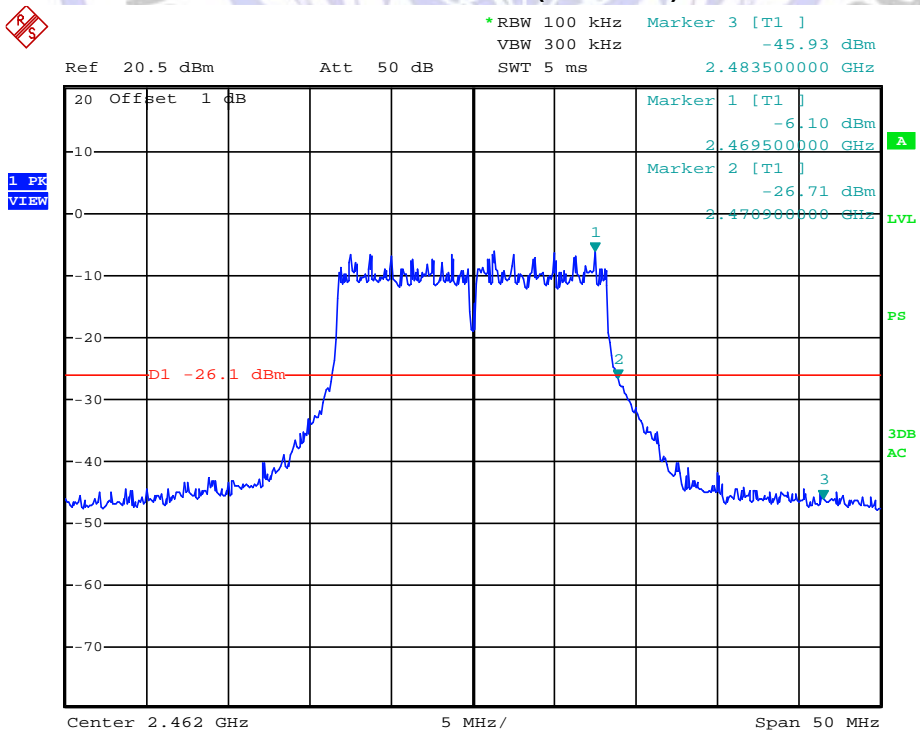

Date: 17.JAN.2014 15:11:30

Product	: HS-7DTB26-4GB
Test Item	: Operation Frequency Range of 20dB Bandwidth
Test Mode	: Mode 3: Transmit by 802.11n (20MHz)

Channel 01 (2412MHz)

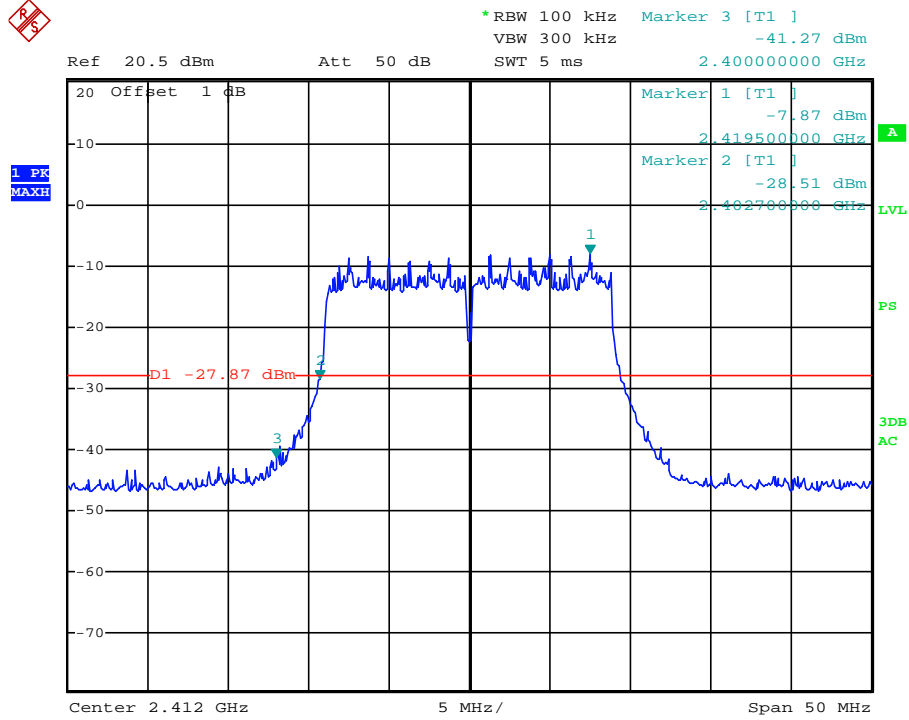

Date: 17.JAN.2014 15:08:02

Channel 11 (2462MHz)

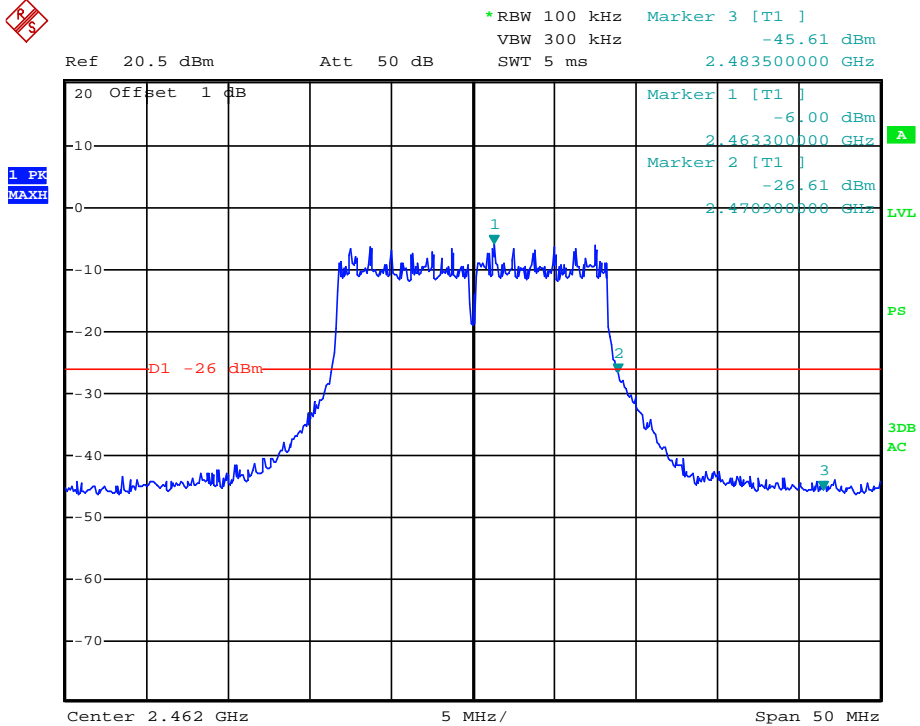

Date: 17.JAN.2014 15:10:35

Product	:	HS-7DTB26-4GB
Test Item	:	Operation Frequency Range of 20dB Bandwidth
Test Mode	:	Mode 4: Transmit by 802.11n (40MHz)

Channel 03 (2422MHz)

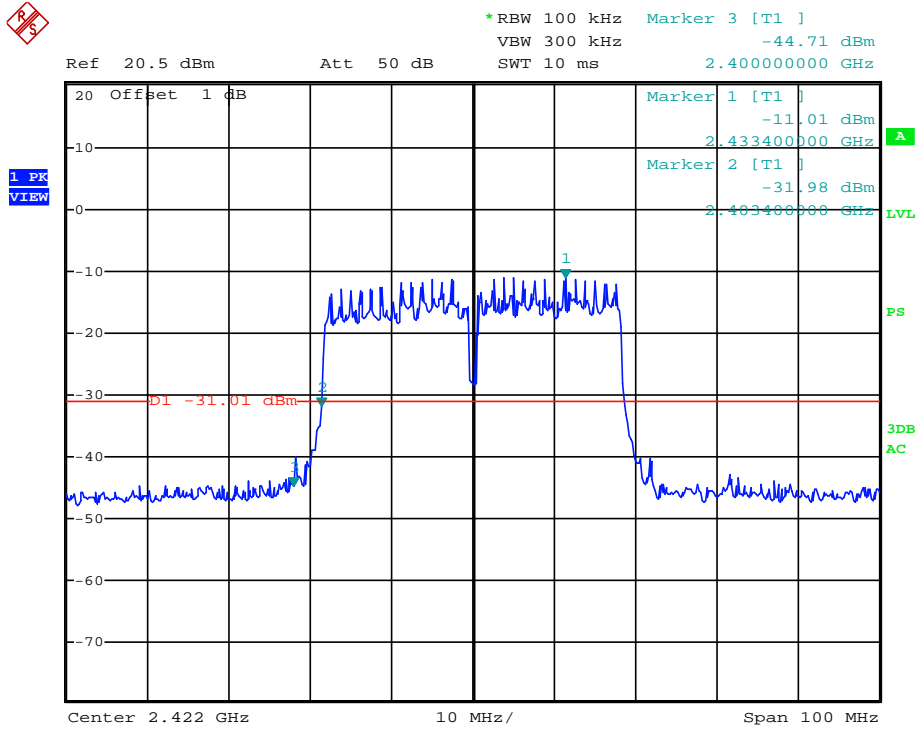

Date: 17.JAN.2014 15:06:34

Channel 09 (2452MHz)

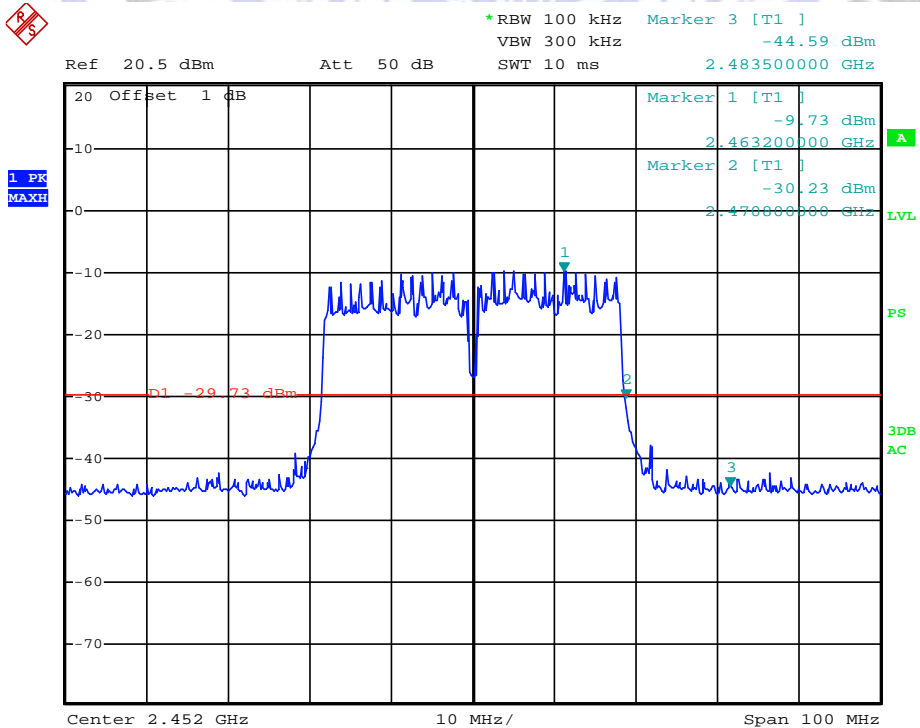

Date: 17.JAN.2014 15:05:21

4.9. Antenna Requirement

STANDARD APPLICABLE

For intentional device, according to FCC 47 CFR Section 15.203, an intentional radiator shall be designed to ensure that no antenna other than that furnished by the responsible party shall be used with the device.

And according to FCC 47 CFR Section 15.247 (c), if transmitting antennas of directional gain greater than 6dBi are used, the power shall be reduced by the amount in dB that the directional gain of the antenna exceeds 6dBi.

Refer to statement below for compliance.

The manufacturer may design the unit so that the user can replace a broken antenna, but the use of a standard antenna jack or electrical connector is prohibited. Further, this requirement does not apply to intentional radiators that must be professionally installed.

ANTENNA CONNECTED CONSTRUCTION

The directional gains of antenna used for transmitting is -0.5 dBi, and the antenna connector is designed with permanent attachment and no consideration of replacement. Please see EUT photo for details.



4.10. RF Exposure

STANDARD APPLICABLE

According to § 1.1307 (b)(1), system operating under the provisions of this section shall be operated in a manner that ensure that the public is not exposed to radio frequency energy level in excess of the Commission’s guideline.

This is a portable device. Per KDB 447498 D01 v05, the device used distance is 5mm from body.

LIMIT

LIMITS FOR MAXIMUM PERMISSIBLE EXPOSURE (MPE)

Frequency Range (MHz)	Electric Field Strength (V/m)	Magnetic Field Strength (A/m)	Power Density (mW/cm ²)	Average Time (Minutes)
(A) Limits for Occupational/ Control Exposures				
300-1500	--	--	F/300	6
1500-100,000	--	--	5	6
(B) Limits for General Population/ Uncontrolled Exposures				
300-1500	--	--	F/1500	6
1500-100,000	--	--	1	30

F= Frequency in MHz

MEASUREMENT RESULTS

Per KDB 447498 D01 V05

This is a bluetooth function and the Max peak output power is 9.52 dBm (8.95 mW) lower than low threshold 10 mW in general population category.

The SAR measurement is not necessary.

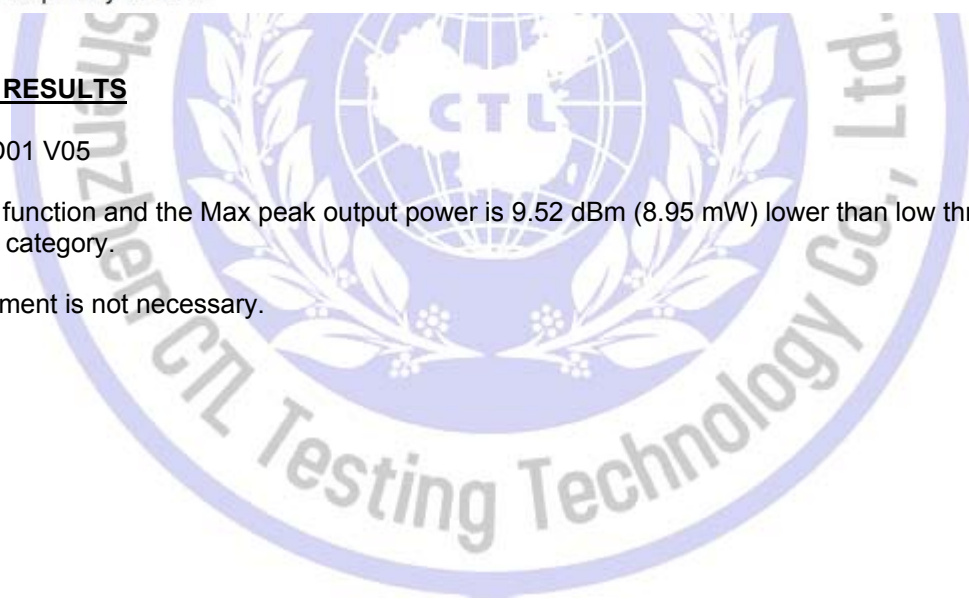

5. Test Setup Photos of the EUT

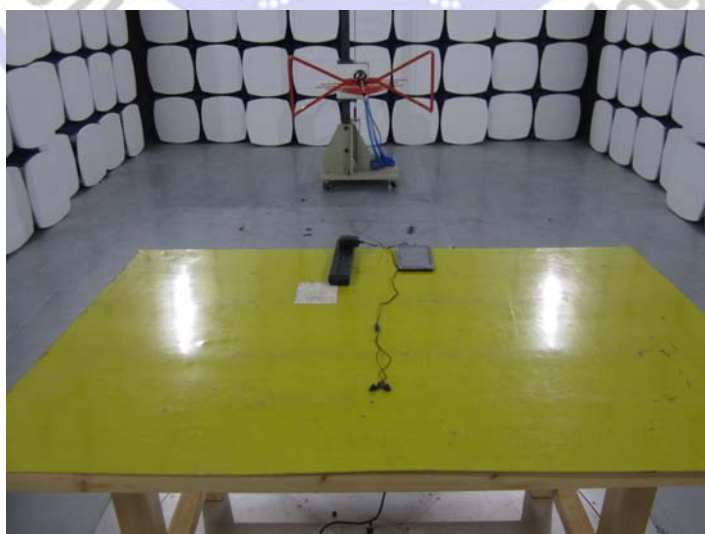
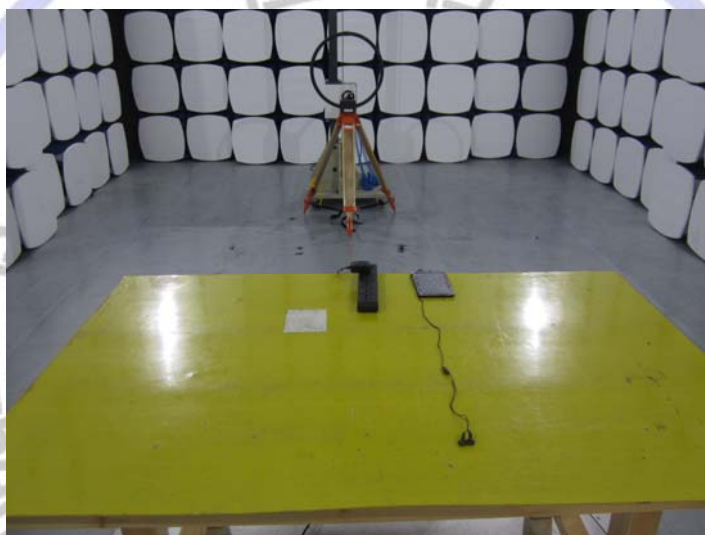



6. External and Internal Photos of the EUT

External Photos of EUT





Internal Photos of EUT



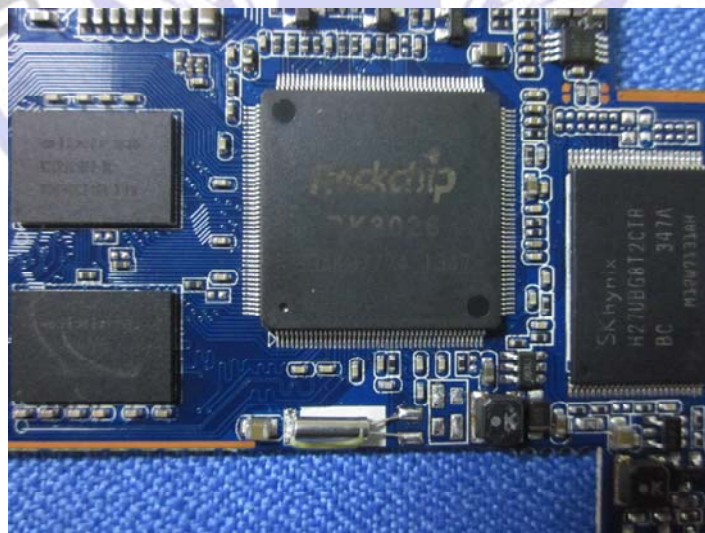
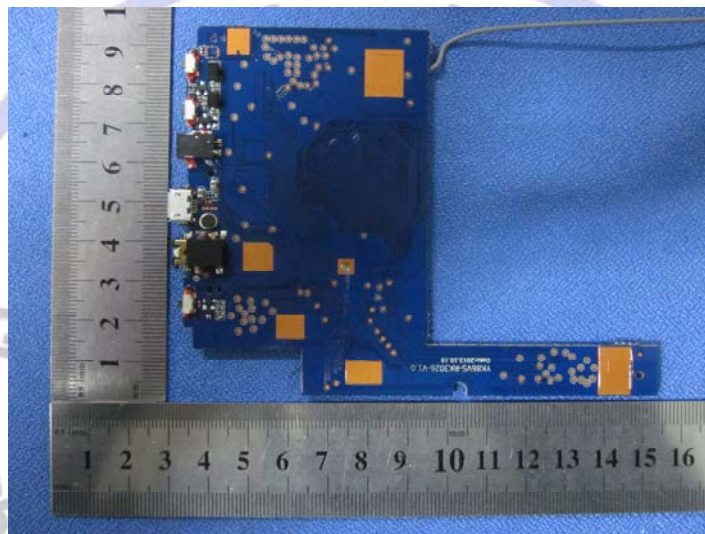
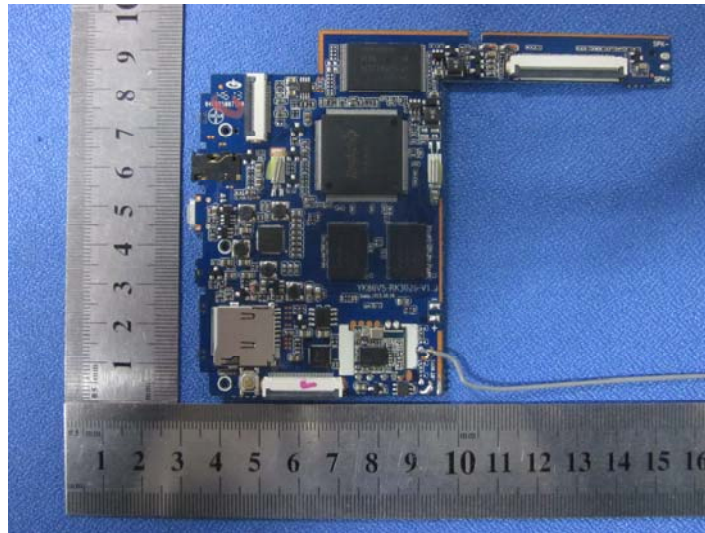

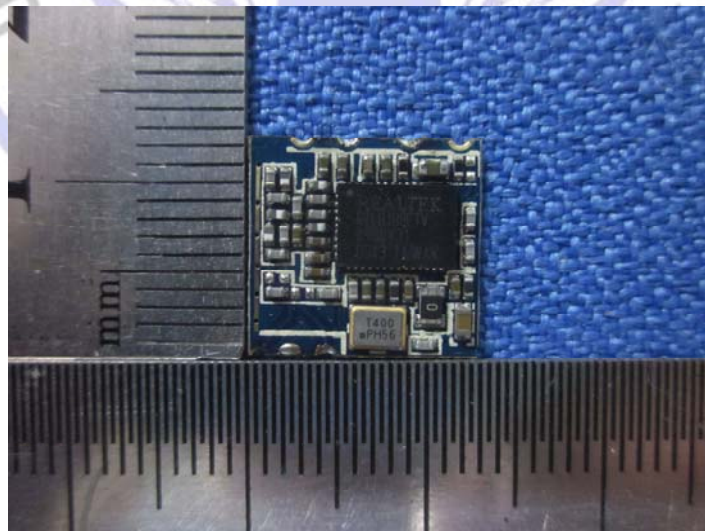
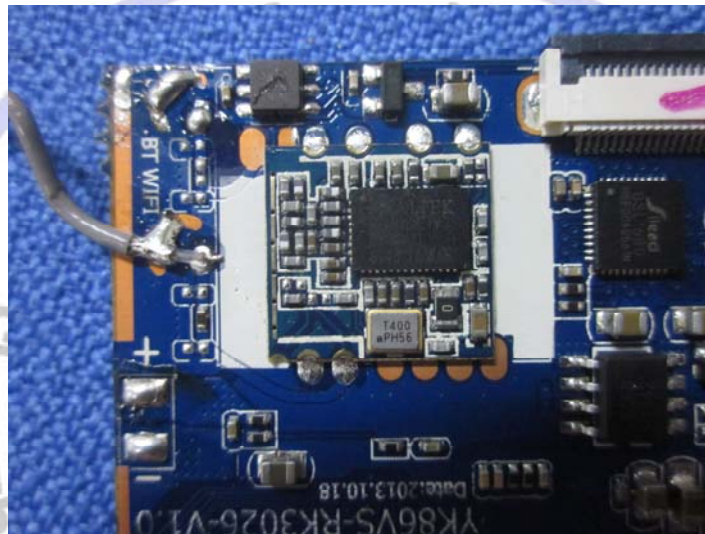

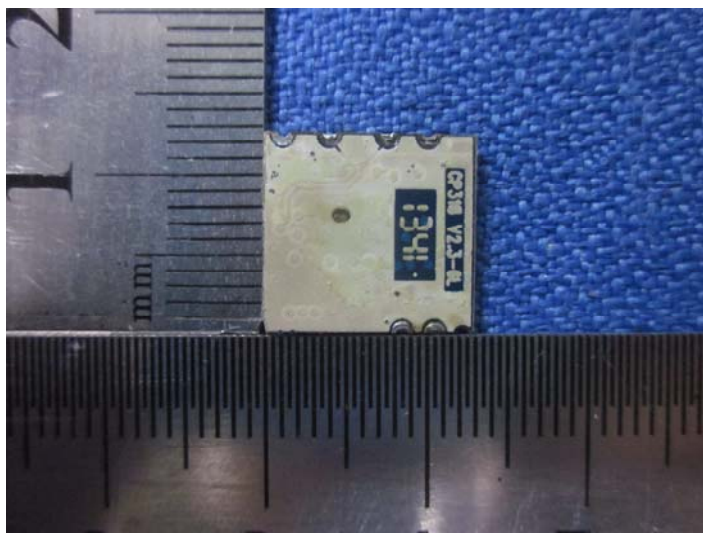

.....End of Report.....

