

FCC TEST REPORT

For

Kobian Canada Inc.

Tablet PC

Model No.: HS-10DTB8

Prepared for : Kobian Canada Inc.  
Address : 560 Denison Street, Unit #5, Markham, Ontario L3R 2M8, Canada

Prepared by : Shenzhen LCS Compliance Testing Laboratory Ltd.  
Address : 1/F., Xingyuan Industrial Park, Tongda Road, Bao'an Avenue,  
Bao'an District, Shenzhen, Guangdong, China

Date of receipt of test sample : September 16, 2013  
Number of tested samples : 1  
Serial number : Prototype  
Date of Test : September 16, 2013 - September 26, 2013  
Date of Report : September 26, 2013

**FCC TEST REPORT**  
**FCC CFR 47 PART 15 C(15.247): 2012**

**Report Reference No. .... : LCS130916347F**

Date of Issue ..... : September 26, 2013

**Testing Laboratory Name..... : Shenzhen LCS Compliance Testing Laboratory Ltd.**

Address ..... : 1/F., Xingyuan Industrial Park, Tongda Road, Bao'an Avenue,  
 Bao'an District, Shenzhen, Guangdong, China

Testing Location/ Procedure..... : Full application of Harmonised standards   
 Partial application of Harmonised standards   
 Other standard testing method

**Applicant's Name..... : Kobian Canada Inc.**

Address ..... : 560 Denison Street, Unit #5, Markham, Ontario L3R 2M8,  
 Canada

**Test Specification**

Standard ..... : FCC CFR 47 PART 15 C(15.247): 2012 / RSS-210 Issue 8/  
 RSS-Gen Issue 3

**Test Report Form No..... : LCSEMC-1.0**

TRF Originator ..... : Shenzhen LCS Compliance Testing Laboratory Ltd.

Master TRF ..... : Dated 2011-03

**Shenzhen LCS Compliance Testing Laboratory Ltd. All rights reserved.**

This publication may be reproduced in whole or in part for non-commercial purposes as long as the Shenzhen LCS Compliance Testing Laboratory Ltd. is acknowledged as copyright owner and source of the material. Shenzhen LCS Compliance Testing Laboratory Ltd. takes no responsibility for and will not assume liability for damages resulting from the reader's interpretation of the reproduced material due to its placement and context.

**Test Item Description. .... : Tablet PC**

Trade Mark ..... : hipstreet

Model/ Type reference..... : HS-10DTB8

Ratings ..... : DC 3.7V by battery(5000mAh)  
 Recharge Voltage: DC 5V

Result ..... : **Positive**

**Compiled by:**

*Leo Lee*

**Supervised by:**

*Fox Zhang*

**Approved by:**

*Gavin Liang*

Leo Lee/ File administrators

Fox Zhang/ Technique principal

Gavin Liang/ Manager

## FCC -- TEST REPORT

|  |  |
|--|--|
| <b>Test Report No. : LCS130916347F</b> | <u>September 26, 2013</u><br>Date of issue |
|--|--|

|                          |  |
|--------------------------|--|
| Type / Model.....        | : HS-10DTB8  |
| EUT.....                 | : Tablet PC  |
| <b>Applicant.....</b>    | <b>: Kobian Canada Inc.</b>  |
| Address.....             | : 560 Denison Street, Unit #5, Markham, Ontario L3R 2M8, Canada                                      |
| Telephone.....           | : /  |
| Fax.....                 | : /  |
| <b>Manufacturer.....</b> | <b>: KINTECH</b>   |
| Address.....             | : 2F, 2 Building, Anda Electron Industrial Zone, Chongqing Road,<br>Fuyong Town, Shenzhen, P.R.China |
| Telephone.....           | : /  |
| Fax.....                 | : /  |
| <b>Factory.....</b>      | <b>: KINTECH</b>   |
| Address.....             | : 2F, 2 Building, Anda Electron Industrial Zone, Chongqing Road,<br>Fuyong Town, Shenzhen, P.R.China |
| Telephone.....           | : /  |
| Fax.....                 | : /  |

|                    |                 |
|--------------------|-----------------|
| <b>Test Result</b> | <b>Positive</b> |
|--------------------|-----------------|

The test report merely corresponds to the test sample.

It is not permitted to copy extracts of these test result without the written permission of the test laboratory.

## TABLE OF CONTENTS

|   |           |
|---|-----------|
| <b>1. GENERAL INFORMATION .....</b>                         | <b>5</b>  |
| 1.1. DESCRIPTION OF DEVICE (EUT) .....                      | 5         |
| 1.2. HOST SYSTEM CONFIGURATION LIST AND DETAILS .....       | 6         |
| 1.3. EXTERNAL I/O CABLE .....                               | 6         |
| 1.4. DESCRIPTION OF TEST FACILITY .....                     | 7         |
| 1.5. STATEMENT OF THE MEASUREMENT UNCERTAINTY .....         | 7         |
| 1.6. MEASUREMENT UNCERTAINTY .....                          | 7         |
| 1.7. DESCRIPTION OF TEST MODES .....                        | 8         |
| <b>2. TEST METHODOLOGY .....</b>                            | <b>9</b>  |
| 2.1. EUT CONFIGURATION .....                                | 9         |
| 2.2. EUT EXERCISE .....                                     | 9         |
| 2.3. GENERAL TEST PROCEDURES .....                          | 9         |
| <b>3. SYSTEM TEST CONFIGURATION .....</b>                   | <b>10</b> |
| 3.1. JUSTIFICATION .....                                    | 10        |
| 3.2. EUT EXERCISE SOFTWARE .....                            | 10        |
| 3.3. SPECIAL ACCESSORIES .....                              | 10        |
| 3.4. BLOCK DIAGRAM/SCHEMATICS .....                         | 10        |
| 3.5. EQUIPMENT MODIFICATIONS .....                          | 10        |
| 3.6. TEST SETUP .....                                       | 10        |
| <b>4. SUMMARY OF TEST RESULTS.....</b>                      | <b>11</b> |
| <b>5. TEST RESULT .....</b>                                 | <b>12</b> |
| 5.1. MAXIMUM CONDUCTED OUTPUT POWER MEASUREMENT .....       | 12        |
| 5.2. POWER SPECTRAL DENSITY MEASUREMENT .....               | 14        |
| 5.3. 6 dB SPECTRUM BANDWIDTH MEASUREMENT .....              | 22        |
| 5.4. OCCUPIED BANDWIDTH .....                               | 30        |
| 5.5. RADIATED EMISSIONS MEASUREMENT.....                    | 38        |
| 5.6. CONDUCTED SPURIOUS EMISSIONS AND BAND EDGES TEST ..... | 51        |
| 5.7. POWER LINE CONDUCTED EMISSIONS .....                   | 62        |
| 5.8. ANTENNA REQUIREMENTS .....                             | 64        |
| <b>6. LIST OF MEASURING EQUIPMENTS.....</b>                 | <b>65</b> |
| <b>7. MANUFACTURER/ APPROVAL HOLDER DECLARATION .....</b>   | <b>66</b> |

## 1. GENERAL INFORMATION

### 1.1. Description of Device (EUT)

|                       |  |
|-----------------------|--|
| EUT                   | : Tablet PC  |
| Model Number          | : HS-10DTB8  |
| Power Supply          | : DC 3.7V by battery(5000mAh)<br>Recharge Voltage: DC 5V   |
| Frequency Range       | : 2412.00-2462.00MHz   |
| Channel Spacing       | : 5MHz   |
| Channel Number        | : 11 Channels for 20MHz Bandwidth<br>7 Channels for 40MHz Bandwidth  |
| Modulation Technology | : IEEE 802.11b: DSSS(CCK,DQPSK,DBPSK)<br>IEEE 802.11g: OFDM(64QAM, 16QAM, QPSK, BPSK)<br>IEEE 802.11n: OFDM (64QAM, 16QAM,QPSK,BPSK) |
| Data Rates            | : IEEE 802.11b: 1-11Mbps<br>IEEE 802.11g: 6-54Mbps<br>IEEE 802.11n: MCS0-MCS15   |
| Antenna Type And Gain | : Integral antenna, 2.0dBi(Max.)   |

### 1.2. Host System Configuration List and Details

| Manufacturer | Description | Model | Serial Number | Certificate |
|--------------|-------------|-------|---------------|-------------|
| Lenovo       | Notebook    | B470  | WB05067151    | DOC         |

### 1.3. External I/O Cable

| Cable Description | Length (M) | From/Port | To |
|-------------------|------------|-----------|----|
| --                | --         | --        | -- |

## 1.4. Description of Test Facility

### Site Description

#### EMC Lab.

: Accredited by CNAS, June 04, 2010

The Certificate Registration Number. is L4595.

Accredited by FCC, July 14, 2011

The Certificate Registration Number. is 899208.

Accredited by Industry Canada, May. 02, 2011

The Certificate Registration Number. is 9642A-1

## 1.5. Statement of The Measurement Uncertainty

The data and results referenced in this document are true and accurate. The reader is cautioned that there may be errors within the calibration limits of the equipment and facilities. The measurement uncertainty was calculated for all measurements listed in this test report acc. To CISPR 16 – 4 “Specification for radio disturbance and immunity measuring apparatus and methods – Part 4: Uncertainty in EMC Measurements” and is documented in the LCS quality system acc. To DIN EN ISO/IEC 17025. Furthermore, component and process variability of devices similar to that tested may result in additional deviation. The manufacturer has the sole responsibility of continued compliance of the device.

## 1.6. Measurement Uncertainty

| Test Item              | Frequency Range | Uncertainty         | Note |
|------------------------|-----------------|---------------------|------|
| Radiation Uncertainty  | 9KHz~30MHz      | $\pm 3.10\text{dB}$ | (1)  |
|                        | 30MHz~200MHz    | $\pm 2.96\text{dB}$ | (1)  |
|                        | 200MHz~1000MHz  | $\pm 3.10\text{dB}$ | (1)  |
|                        | 1GHz~26.5GHz    | $\pm 3.80\text{dB}$ | (1)  |
|                        | 26.5GHz~40GHz   | $\pm 3.90\text{dB}$ | (1)  |
| Conduction Uncertainty | 150kHz~30MHz    | $\pm 1.63\text{dB}$ | (1)  |
| Power disturbance      | 30MHz~300MHz    | $\pm 1.60\text{dB}$ | (1)  |

(1). This uncertainty represents an expanded uncertainty expressed at approximately the 95% confidence level using a coverage factor of  $k=2$ .

## 1.7. Description Of Test Modes

The EUT has been tested under operating condition.

This test was performed with EUT in X, Y, Z position and the worse case was found when EUT in Y position.

Worst-case mode and channel used for 150kHz-30 MHz power line conducted emissions was the mode and channel with the highest output power, that was determined to be 802.11b mode(Low Channel).

Worst-case mode and channel used for 9kHz-1000 MHz radiated emissions was the mode and channel with the highest output power, that was determined to be 802.11b mode(Low Channel).

Worst-Case data rates were utilized from preliminary testing of the Chipset, worst-case data rates used during the testing are as follows:

802.11b Mode : 1 Mbps, DSSS.

802.11g Mode : 6 Mbps, OFDM.

802.11n Mode HT20:.MCS0, OFDM.

802.11n Mode HT40:.MCS8, OFDM.

### Channel List & Frequency

#### 802.11b/g/n(HT20)

| Frequency Band | Channel No. | Frequency(MHz) | Channel No. | Frequency(MHz) |
|----------------|-------------|----------------|-------------|----------------|
| 2412~2462MHz   | 1           | 2412           | 7           | 2442           |
|                | 2           | 2417           | 8           | 2447           |
|                | 3           | 2422           | 9           | 2452           |
|                | 4           | 2427           | 10          | 2457           |
|                | 5           | 2432           | 11          | 2462           |
|                | 6           | 2437           | --          | --             |

#### 802.11n(HT40)

| Frequency Band | Channel No. | Frequency(MHz) | Channel No. | Frequency(MHz) |
|----------------|-------------|----------------|-------------|----------------|
| 2412~2462MHz   | 1           | --             | 7           | 2442           |
|                | 2           | --             | 8           | 2447           |
|                | 3           | 2422           | 9           | 2452           |
|                | 4           | 2427           | 10          | --             |
|                | 5           | 2432           | 11          | --             |
|                | 6           | 2437           | --          | --             |



## 2. TEST METHODOLOGY

All measurements contained in this report were conducted with ANSI C63.4-2003, American National Standard for Methods of Measurement of Radio-Noise Emissions from Low-Voltage Electrical and Electronic Equipment in the range of 9 kHz to 40 GHz.

The radiated testing was performed at an antenna-to-EUT distance of 3 meters. All radiated and conducted emissions measurement was performed at Shenzhen LCS Compliance Testing Laboratory Ltd..

### 2.1. EUT Configuration

The EUT configuration for testing is installed on RF field strength measurement to meet the Commissions requirement and operating in a manner that intends to maximize its emission characteristics in a continuous normal application.

### 2.2. EUT Exercise

The EUT was operated in the engineering mode to fix the TX frequency that was for the purpose of the measurements.

According to FCC's request, Test Procedure KDB558074 D01 DTS Meas. Guidance v03r01 is required to be used for this kind of FCC 15.247 digital modulation device.

According to its specifications, the EUT must comply with the requirements of the Section 15.203, 15.205, 15.207, 15.209 and 15.247 under the FCC Rules Part 15 Subpart C and RSS-210.

### 2.3. General Test Procedures

#### 2.3.1 Conducted Emissions

The EUT is placed on the turntable, which is 0.8 m above ground plane. According to the requirements in Section 13.1.4.1 of ANSI C63.4 Conducted emissions from the EUT measured in the frequency range between 0.15 MHz and 30MHz using Quasi-peak and average detector modes.

#### 2.3.2 Radiated Emissions

The EUT is placed on a turn table, which is 0.8 m above ground plane. The turntable shall rotate 360 degrees to determine the position of maximum emission level. EUT is set 3m away from the receiving antenna, which varied from 1m to 4m to find out the highest emission. And also, each emission was to be maximized by changing the polarization of receiving antenna both horizontal and vertical. In order to find out the maximum emissions, exploratory radiated emission measurements were made according to the requirements in Section 13.1.4.1 of ANSI C63.4

### 3. SYSTEM TEST CONFIGURATION

#### 3.1. Justification

The system was configured for testing in a continuous transmit condition.

#### 3.2. EUT Exercise Software

N/A

#### 3.3. Special Accessories

N/A

#### 3.4. Block Diagram/Schematics

Please refer to the related document

#### 3.5. Equipment Modifications

Shenzhen LCS Compliance Testing Laboratory Ltd. has not done any modification on the EUT.

#### 3.6. Test Setup

Please refer to the test setup photo.

## 4. SUMMARY OF TEST RESULTS

| Applied Standard: FCC Part 15 Subpart C & RSS-210 |          |   |           |
|---|----------|---|-----------|
| FCC Rules   | IC Rules | Description of Test                       | Result    |
| §15.247(b)  | A8.4     | Maximum Conducted Output Power            | Compliant |
| §15.247(e)  | A8.2(b)  | Power Spectral Density                    | Compliant |
| §15.247(a)(2)                                     | A8.2(a)  | 6dB Bandwidth                             | Compliant |
| §15.247(a)  | A8.2(a)  | Occupied Bandwidth                        | Compliant |
| §15.209,<br>§15.247(d)                            | A8.5     | Radiated and Conducted Spurious Emissions | Compliant |
| §15.205   | A8.5     | Emissions at Restricted Band              | Compliant |
| §15.207(a)  | RSS-Gen  | Conducted Emissions                       | Compliant |
| §15.203   | RSS-Gen  | Antenna Requirements                      | Compliant |
| §15.247(i)§<br>2.1093                             | RSS-102  | RF Exposure                               | Compliant |

## 5. TEST RESULT

### 5.1. Maximum Conducted Output Power Measurement

#### 5.1.1. Standard Applicable

According to §15.247(b) & A8.4: For systems using digital modulation in the 2400-2483.5 MHz and 5725-5850 MHz band, the limit for maximum peak conducted output power is 30dBm. The limit has to be reduced by the amount in dB that the gain of the antenna exceeds 6dBi. In case of point-to-point operation, the limit has to be reduced by 1dB for every 3dB that the directional gain of the antenna exceeds 6dBi.

Systems operating in the 5725-5850 MHz band that are used exclusively for fixed, point-to-point operations may employ transmitting antennas with directional gain greater than 6dBi without any corresponding reduction in transmitter peak output power.

#### 5.1.2. Measuring Instruments

Please refer to section 6 of equipments list in this report.

#### 5.1.3. Test Procedures

The transmitter output (antenna port) was connected to the power meter.

#### 5.1.4. Test Setup Layout

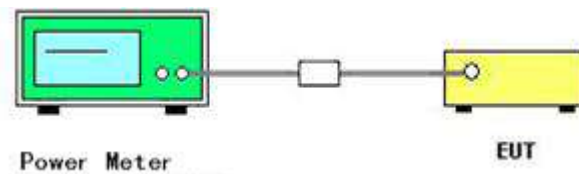

#### 5.1.5. EUT Operation during Test

The EUT was programmed to be in continuously transmitting mode.

5.1.6. Test Result of Maximum Conducted Output Power

|               |      |                |             |
|---------------|------|----------------|-------------|
| Temperature   | 25°C | Humidity       | 60%         |
| Test Engineer | Tree | Configurations | 802.11b/g/n |

802.11b

| Channel | Frequency (MHz) | Conducted Peak Power (dBm) | Max. Limit (dBm) | Result   |
|---------|-----------------|----------------------------|------------------|----------|
| 1       | 2412            | 7.43                       | 30               | Complies |
| 6       | 2437            | 7.31                       | 30               | Complies |
| 11      | 2462            | 7.25                       | 30               | Complies |

802.11g

| Channel | Frequency (MHz) | Conducted Peak Power (dBm) | Max. Limit (dBm) | Result   |
|---------|-----------------|----------------------------|------------------|----------|
| 1       | 2412            | 7.34                       | 30               | Complies |
| 6       | 2437            | 7.25                       | 30               | Complies |
| 11      | 2462            | 7.06                       | 30               | Complies |

802.11n HT20

| Channel | Frequency (MHz) | Conducted Peak Power (dBm) | Max. Limit (dBm) | Result   |
|---------|-----------------|----------------------------|------------------|----------|
| 1       | 2412            | 6.57                       | 30               | Complies |
| 6       | 2437            | 6.48                       | 30               | Complies |
| 11      | 2462            | 6.39                       | 30               | Complies |

802.11n HT40

| Channel | Frequency (MHz) | Conducted Peak Power (dBm) | Max. Limit (dBm) | Result   |
|---------|-----------------|----------------------------|------------------|----------|
| 3       | 2422            | 5.49                       | 30               | Complies |
| 6       | 2437            | 5.37                       | 30               | Complies |
| 9       | 2452            | 5.21                       | 30               | Complies |

## 5.2. Power Spectral Density Measurement

### 5.2.1. Standard Applicable

According to §15.247(e) & A8.2(b): For digitally modulated systems, the power spectral density conducted from the intentional radiator to the antenna shall not be greater than 8 dBm in any 3 kHz band during any time interval of continuous transmission.

### 5.2.2. Measuring Instruments

Please refer to section 6 of equipments list in this report.

### 5.2.3. Test Procedures

1. The transmitter was connected directly to a Spectrum Analyzer through a directional couple.
2. The power was monitored at the coupler port with a Spectrum Analyzer. The power level was set to the maximum level.
3. Set the RBW = 3 kHz.
4. Set the VBW  $\geq 3 \times$  RBW
5. Set the span to 1.5 times the DTS channel bandwidth.
6. Detector = peak.
7. Sweep time = auto couple.
8. Trace mode = max hold.
9. Allow trace to fully stabilize.
10. Use the peak marker function to determine the maximum power level in any 3 kHz band segment within the fundamental EBW.

### 5.2.4. Test Setup Layout

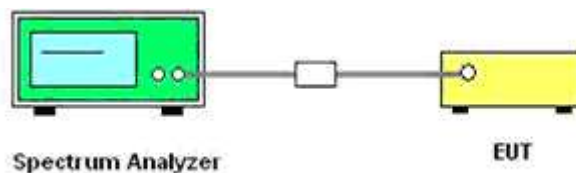

### 5.2.5. EUT Operation during Test

The EUT was programmed to be in continuously transmitting mode.

## 5.2.6. Test Result of Power Spectral Density

|               |      |                |             |
|---------------|------|----------------|-------------|
| Temperature   | 25°C | Humidity       | 60%         |
| Test Engineer | Tree | Configurations | 802.11b/g/n |

## 802.11b

| Channel | Frequency (MHz) | Power Density (dBm/3KHz) | Max. Limit (dBm/3KHz) | Result   |
|---------|-----------------|--------------------------|-----------------------|----------|
| 1       | 2412            | -16.93                   | 8                     | Complies |
| 6       | 2437            | -18.38                   | 8                     | Complies |
| 11      | 2462            | -18.92                   | 8                     | Complies |

## 802.11g

| Channel | Frequency (MHz) | Power Density (dBm/3KHz) | Max. Limit (dBm/3KHz) | Result   |
|---------|-----------------|--------------------------|-----------------------|----------|
| 1       | 2412            | -18.43                   | 8                     | Complies |
| 6       | 2437            | -19.64                   | 8                     | Complies |
| 11      | 2462            | -19.93                   | 8                     | Complies |

## 802.11n HT20

| Channel | Frequency (MHz) | Power Density (dBm/3KHz) | Max. Limit (dBm/3KHz) | Result   |
|---------|-----------------|--------------------------|-----------------------|----------|
| 1       | 2412            | -20.23                   | 8                     | Complies |
| 6       | 2437            | -21.43                   | 8                     | Complies |
| 11      | 2462            | -21.69                   | 8                     | Complies |

## 802.11n HT40

| Channel | Frequency (MHz) | Power Density (dBm/3KHz) | Max. Limit (dBm/3KHz) | Result   |
|---------|-----------------|--------------------------|-----------------------|----------|
| 3       | 2422            | -15.94                   | 8                     | Complies |
| 6       | 2437            | -16.55                   | 8                     | Complies |
| 9       | 2452            | -17.27                   | 8                     | Complies |

802.11b power density

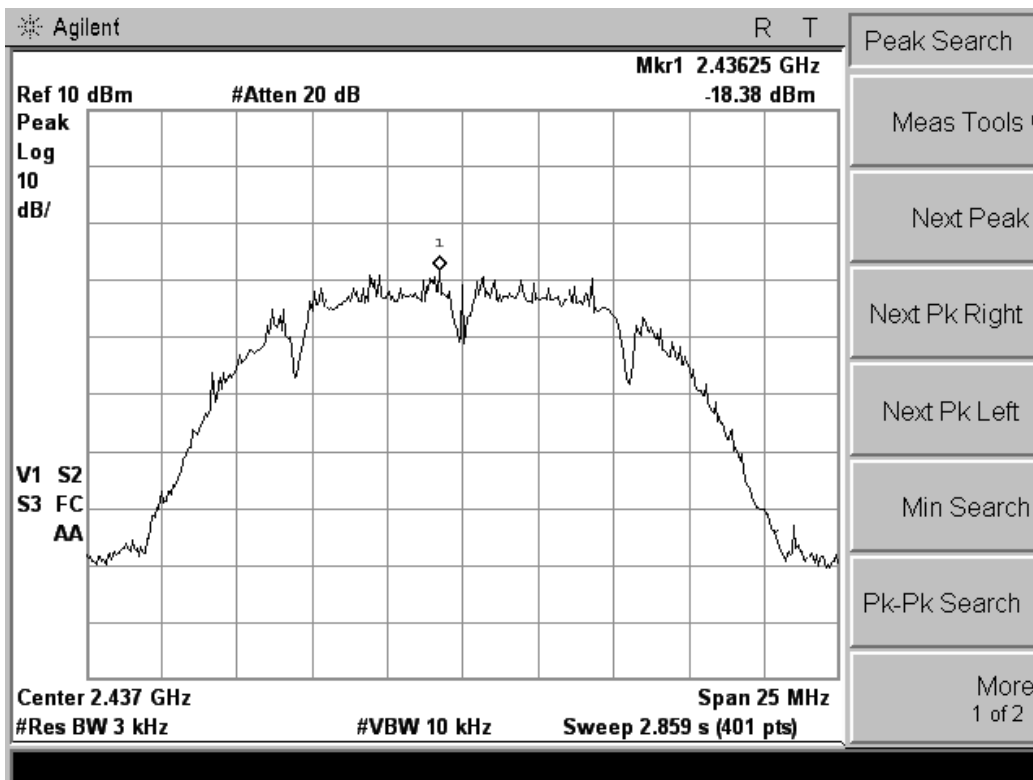
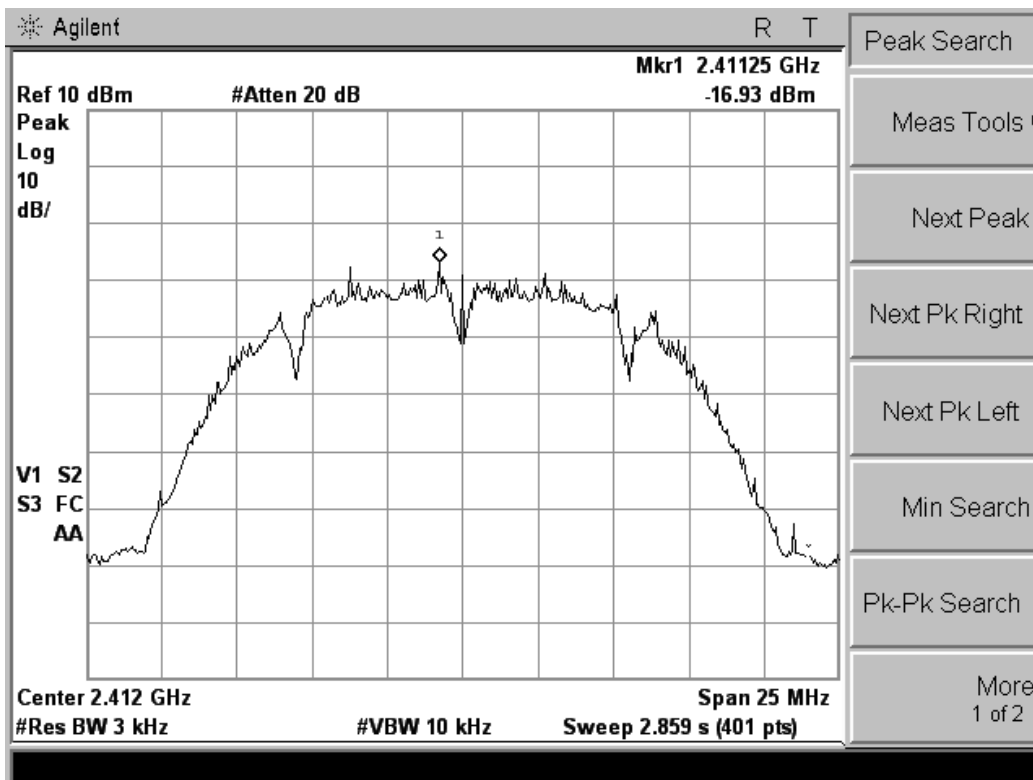



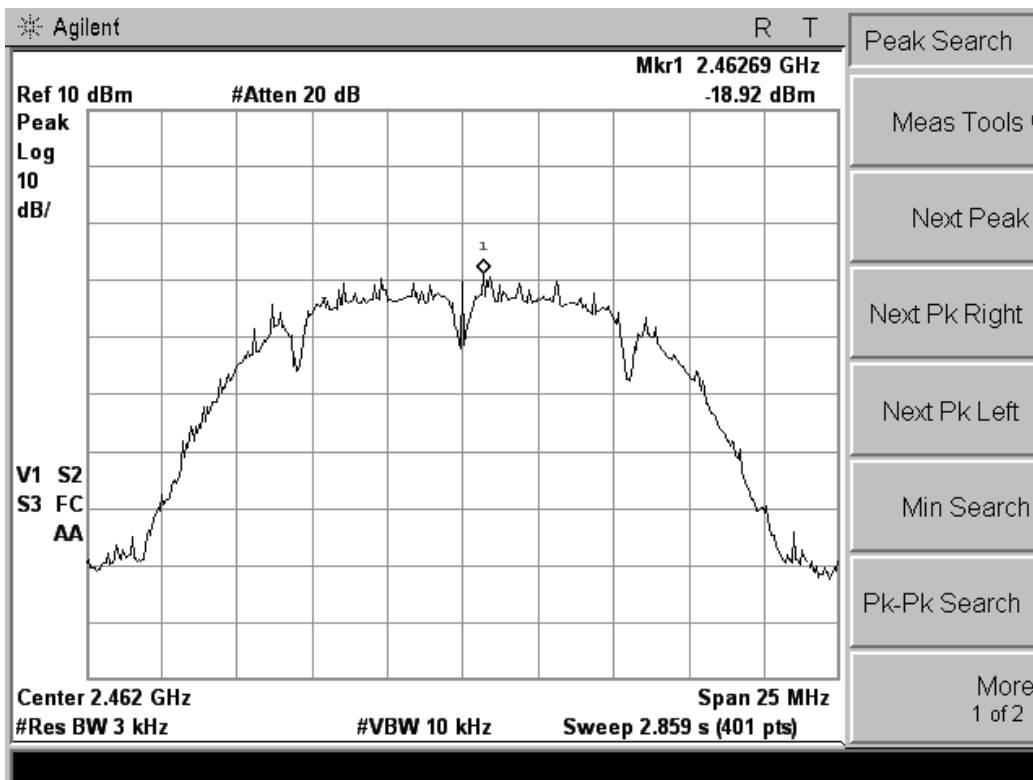

802.11g power density

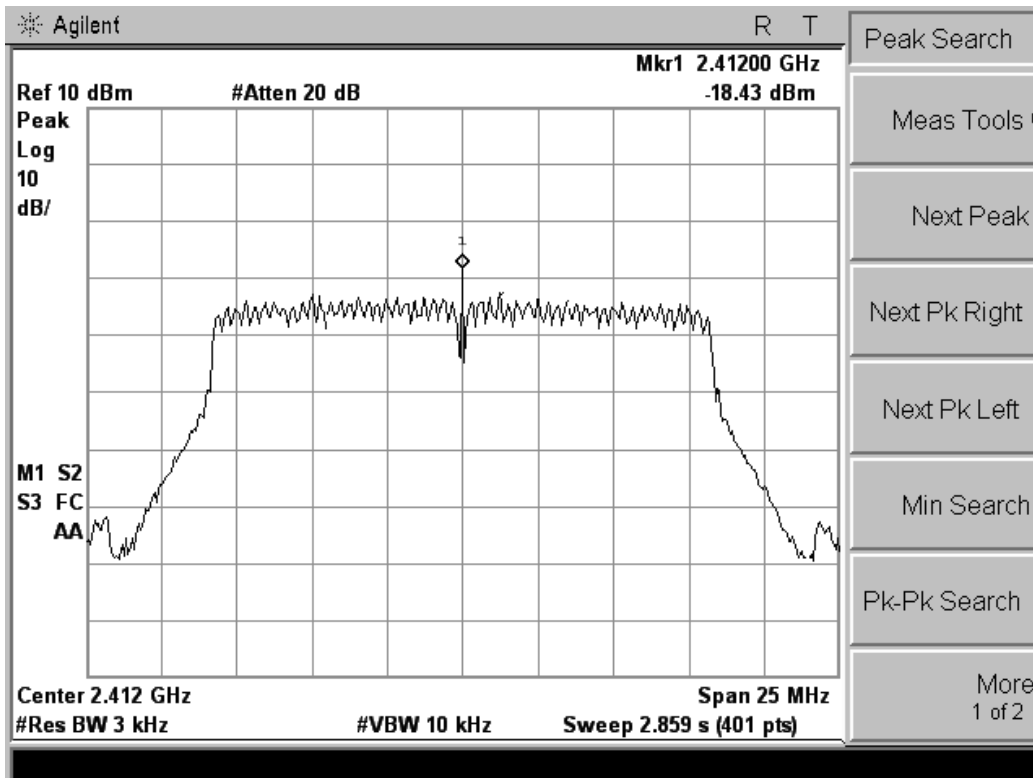

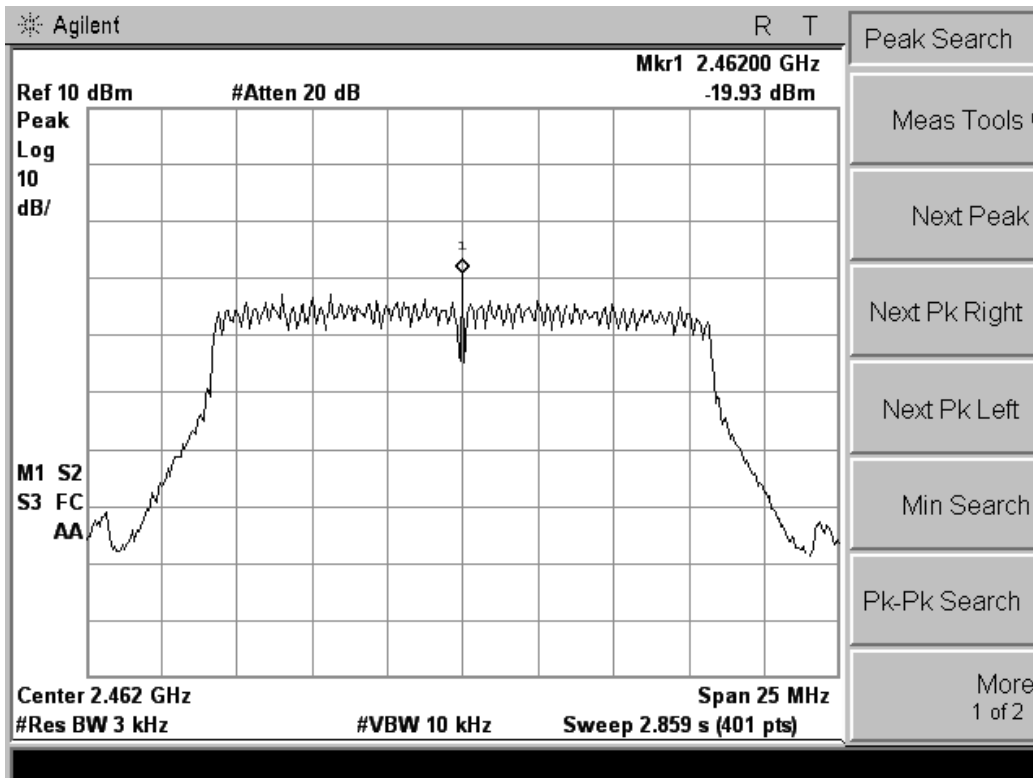
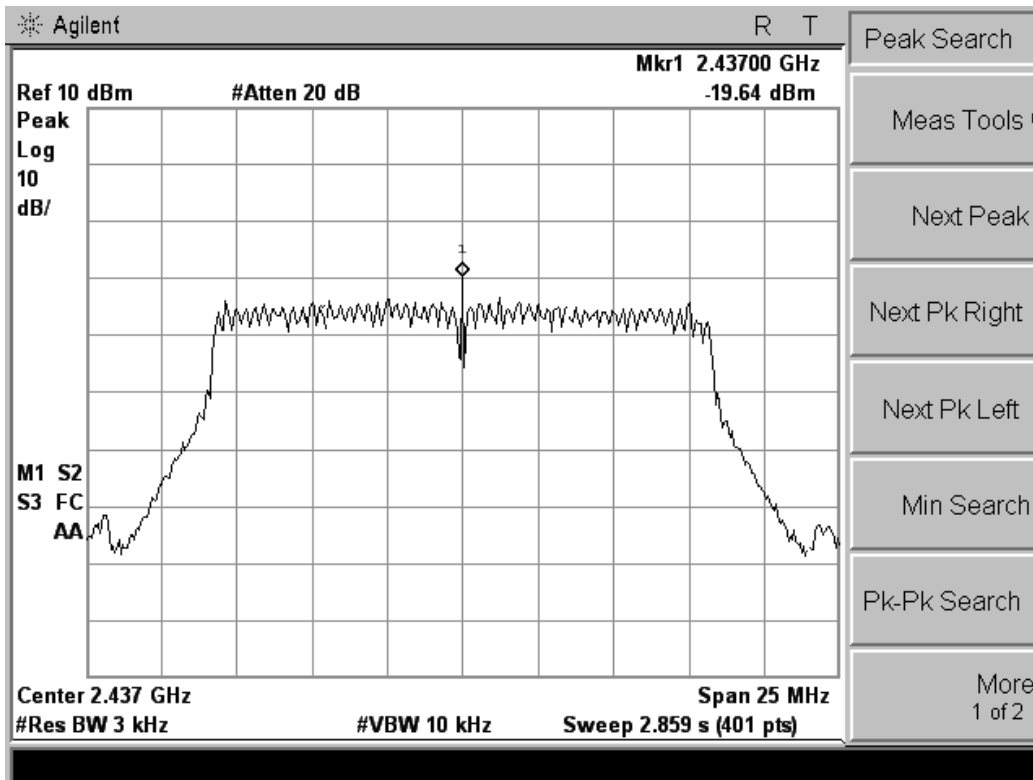

802.11n HT20 power density

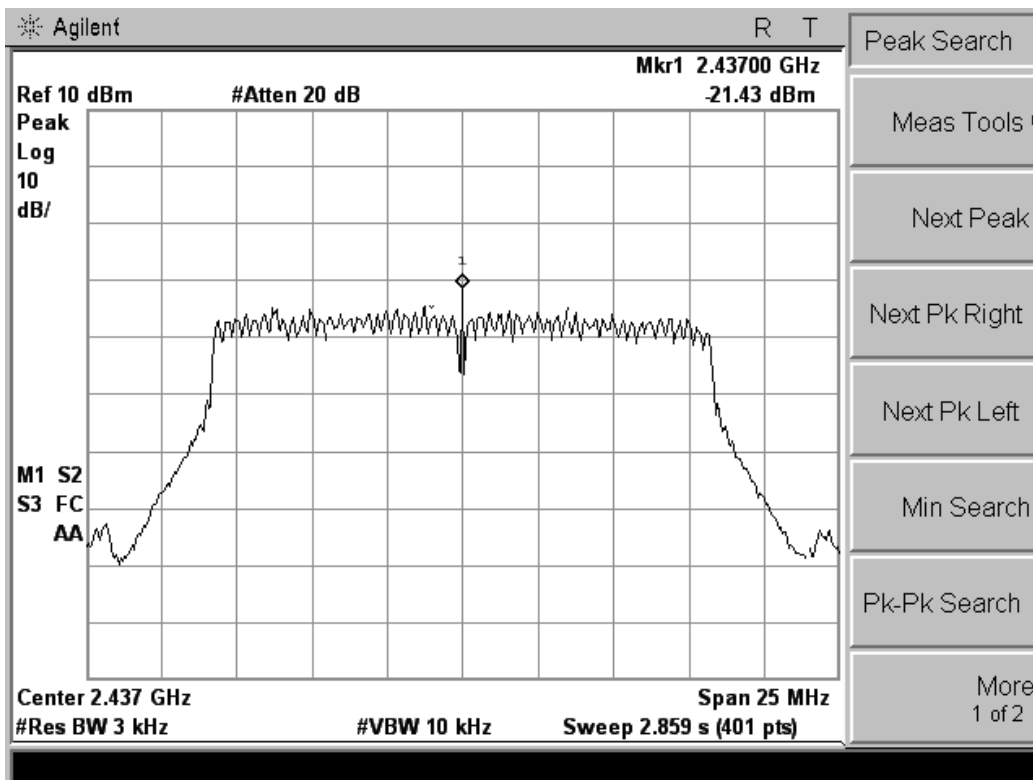
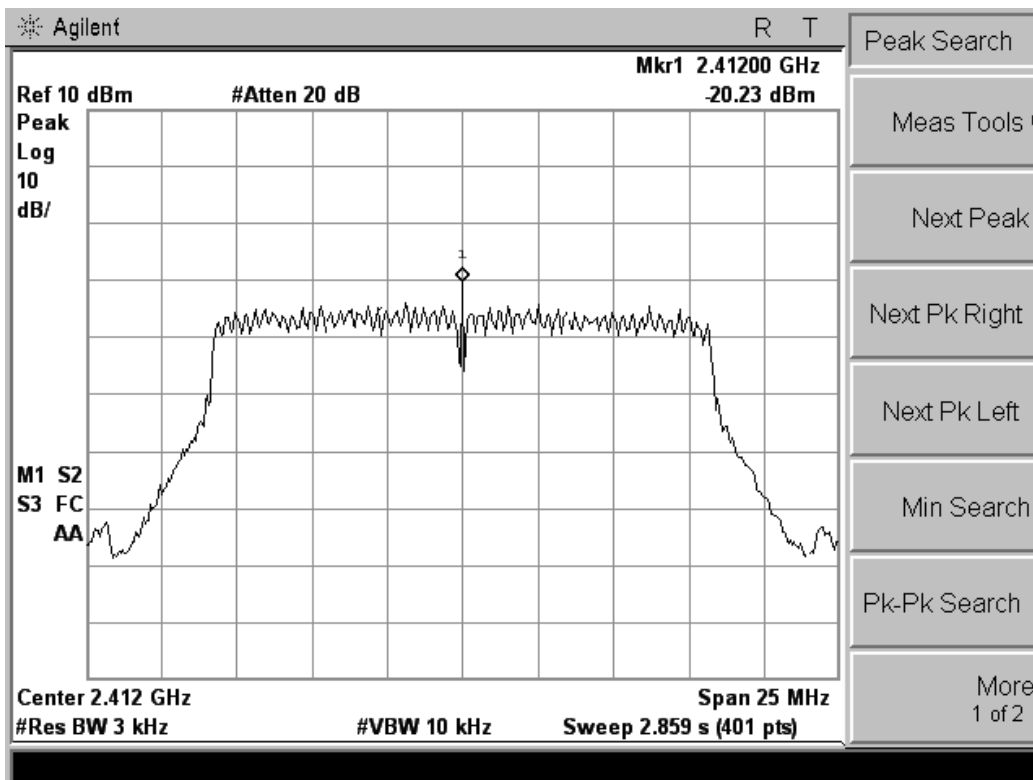

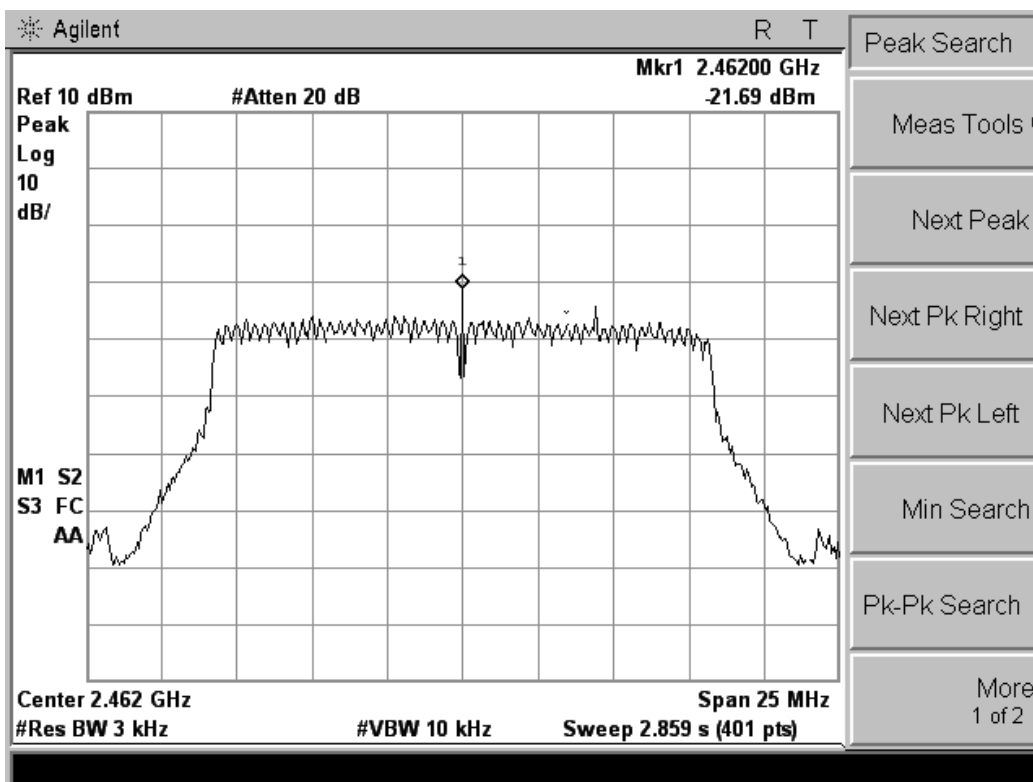

802.11n HT40 power density

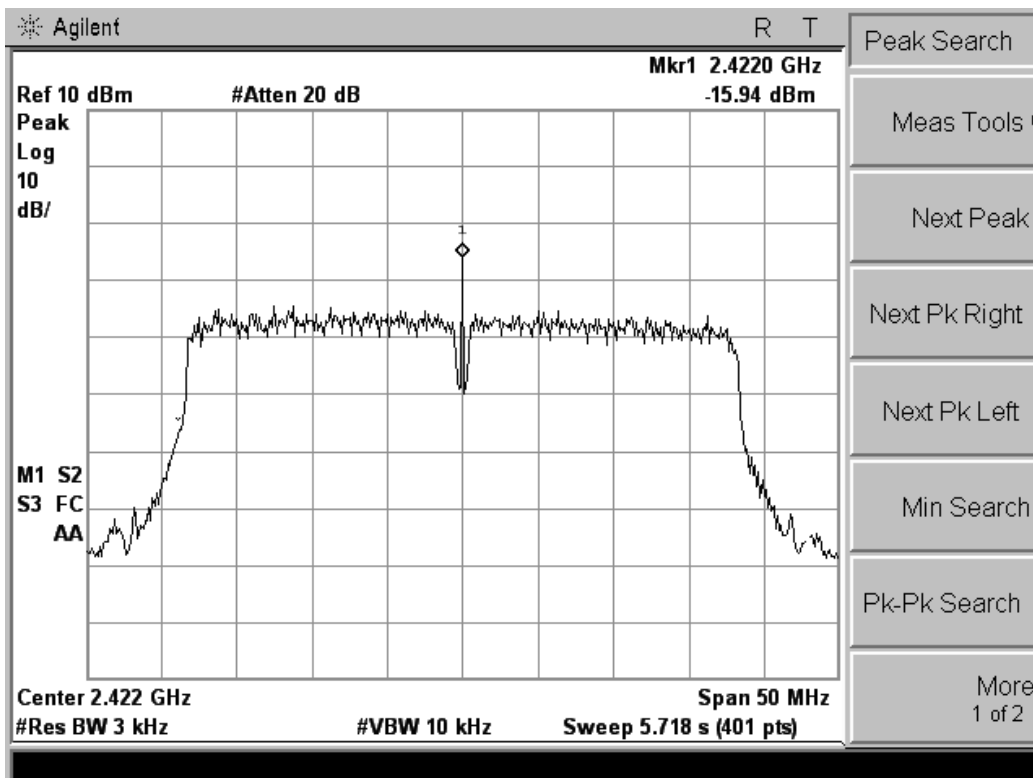

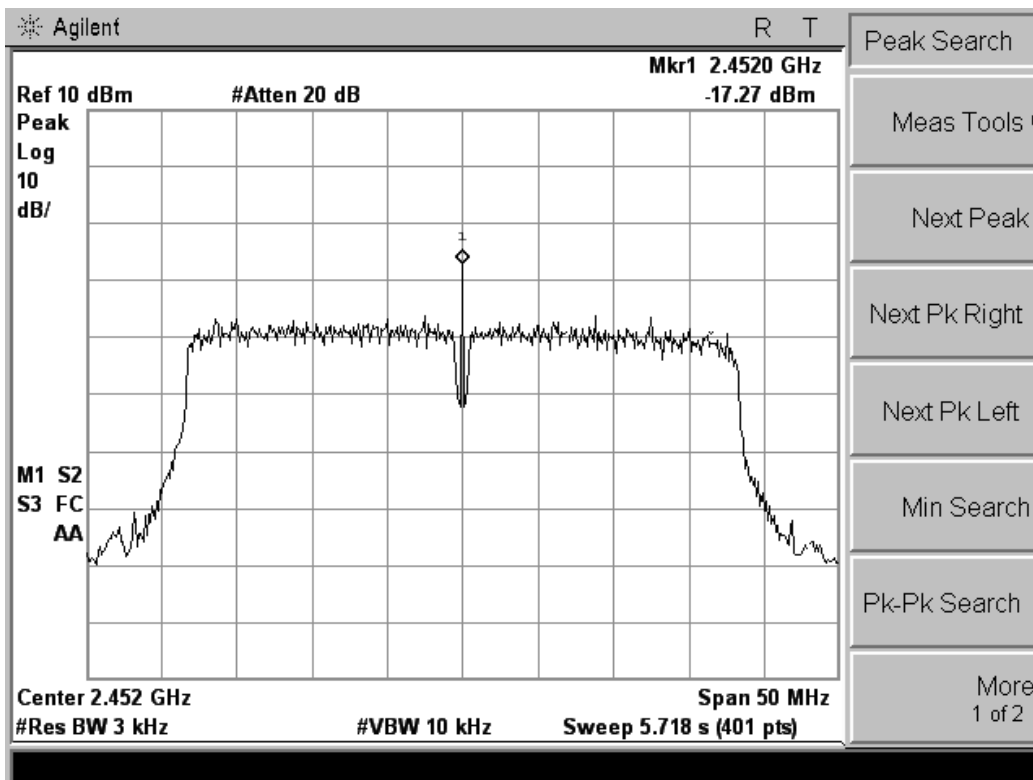
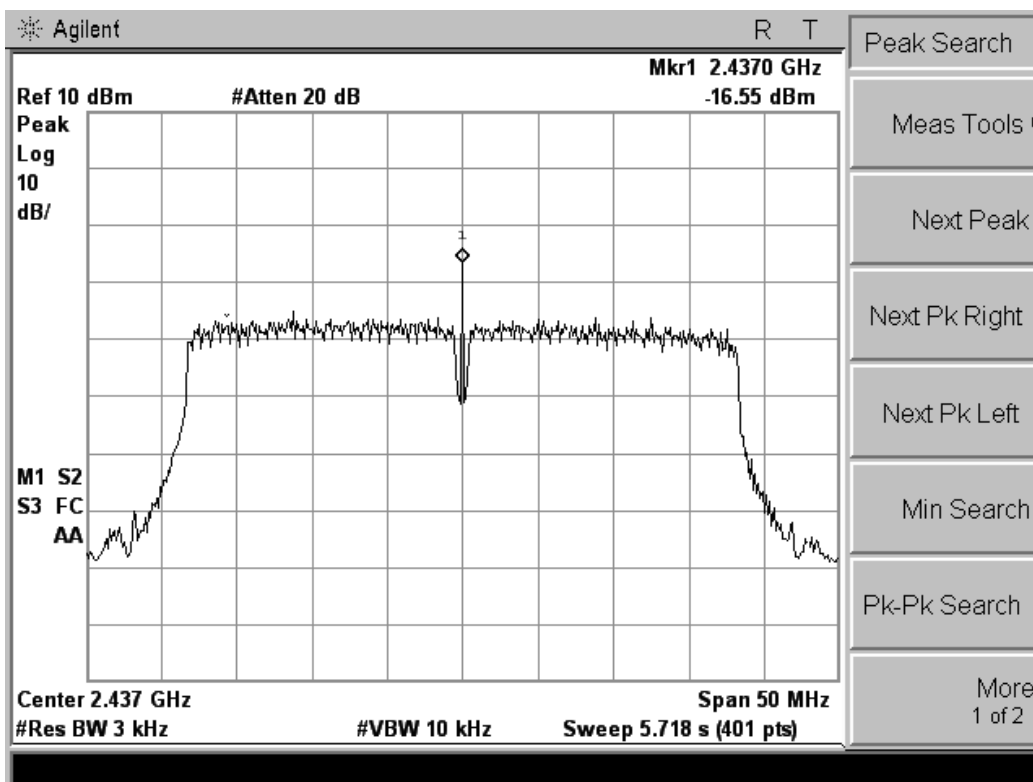

### 5.3. 6 dB Spectrum Bandwidth Measurement

#### 5.3.1. Standard Applicable

According to §15.247(a)(2) & A8.2(a): For digital modulation systems, the minimum 6 dB bandwidth shall be at least 500 kHz.

#### 5.3.2. Measuring Instruments and Setting

Please refer to section 6 of equipments list in this report. The following table is the setting of the Spectrum Analyzer.

|                    |          |
|--------------------|----------|
| Spectrum Parameter | Setting  |
| Attenuation        | Auto     |
| Span Frequency     | > RBW    |
| Detector           | Peak     |
| Trace              | Max Hold |
| Sweep Time         | 100ms    |

#### 5.3.3. Test Procedures

1. The transmitter output (antenna port) was connected to the spectrum analyser in peak hold mode.
2. The resolution bandwidth and the video bandwidth were set according to KDB558074.
3. Measured the spectrum width with power higher than 6dB below carrier.

#### 5.3.4. Test Setup Layout

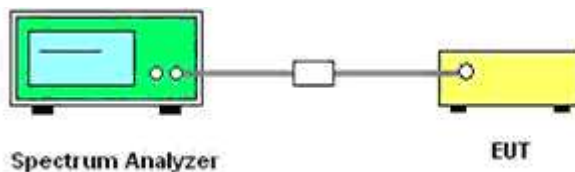

#### 5.3.5. EUT Operation during Test

The EUT was programmed to be in continuously transmitting mode.

#### 5.3.6. Test Result of 6dB Spectrum Bandwidth

|               |      |                |             |
|---------------|------|----------------|-------------|
| Temperature   | 25°C | Humidity       | 60%         |
| Test Engineer | Tree | Configurations | 802.11b/g/n |

802.11b

| Channel | Frequency | 6dB Bandwidth (MHz) | Min. Limit (kHz) | Result   |
|---------|-----------|---------------------|------------------|----------|
| 1       | 2412      | 11.132              | 500              | Complies |
| 6       | 2437      | 11.164              | 500              | Complies |
| 11      | 2462      | 11.183              | 500              | Complies |

802.11g

| Channel | Frequency | 6dB Bandwidth (MHz) | Min. Limit (kHz) | Result   |
|---------|-----------|---------------------|------------------|----------|
| 1       | 2412      | 16.330              | 500              | Complies |
| 6       | 2437      | 16.134              | 500              | Complies |
| 11      | 2462      | 16.131              | 500              | Complies |

802.11n HT20

| Channel | Frequency | 6dB Bandwidth (MHz) | Min. Limit (kHz) | Result   |
|---------|-----------|---------------------|------------------|----------|
| 1       | 2412      | 16.131              | 500              | Complies |
| 6       | 2437      | 16.323              | 500              | Complies |
| 11      | 2462      | 16.113              | 500              | Complies |

802.11n HT40

| Channel | Frequency | 6dB Bandwidth (MHz) | Min. Limit (kHz) | Result   |
|---------|-----------|---------------------|------------------|----------|
| 3       | 2422      | 35.268              | 500              | Complies |
| 6       | 2437      | 35.292              | 500              | Complies |
| 9       | 2452      | 35.324              | 500              | Complies |

802.11b channel, 6dB bandwidth

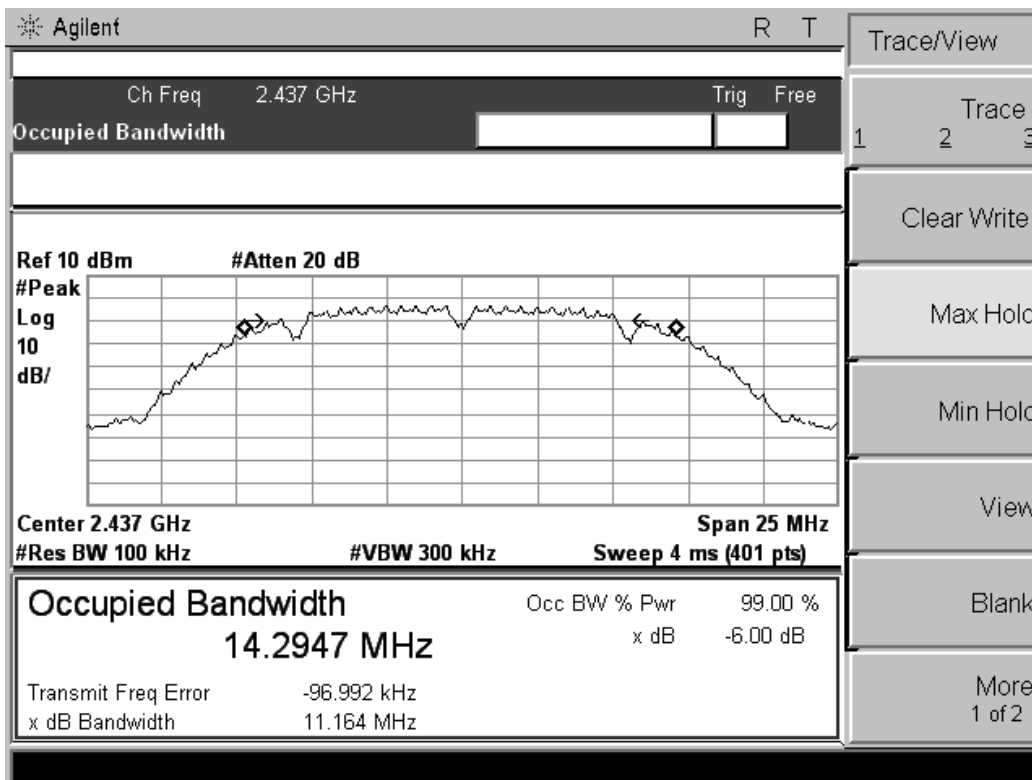
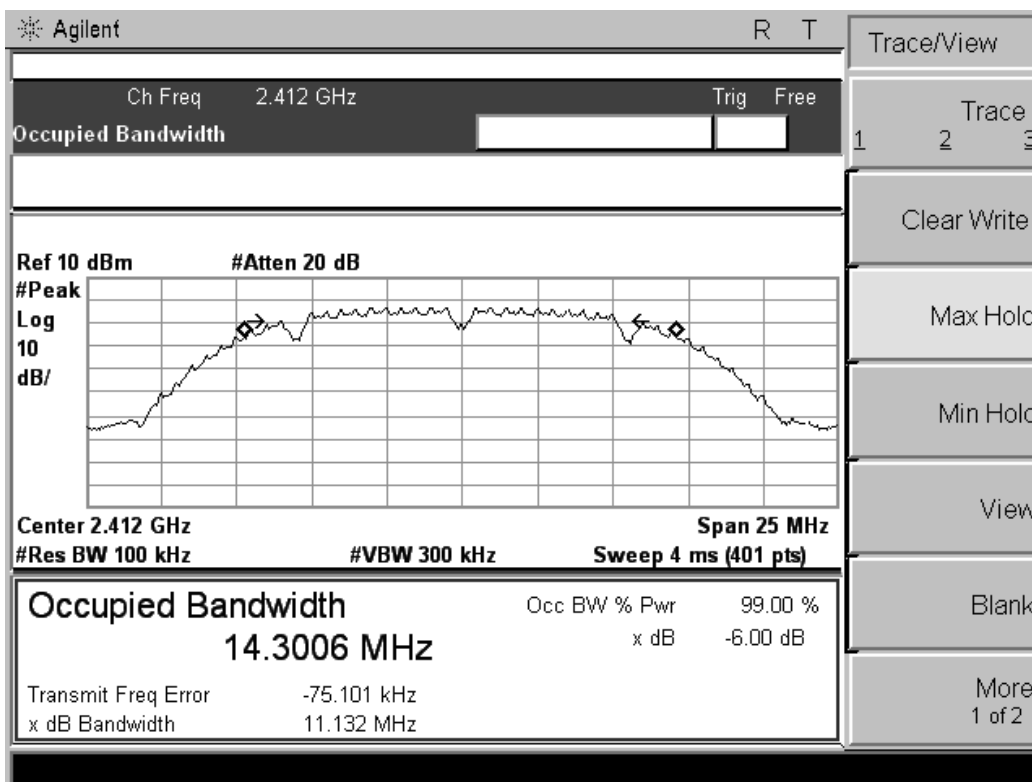



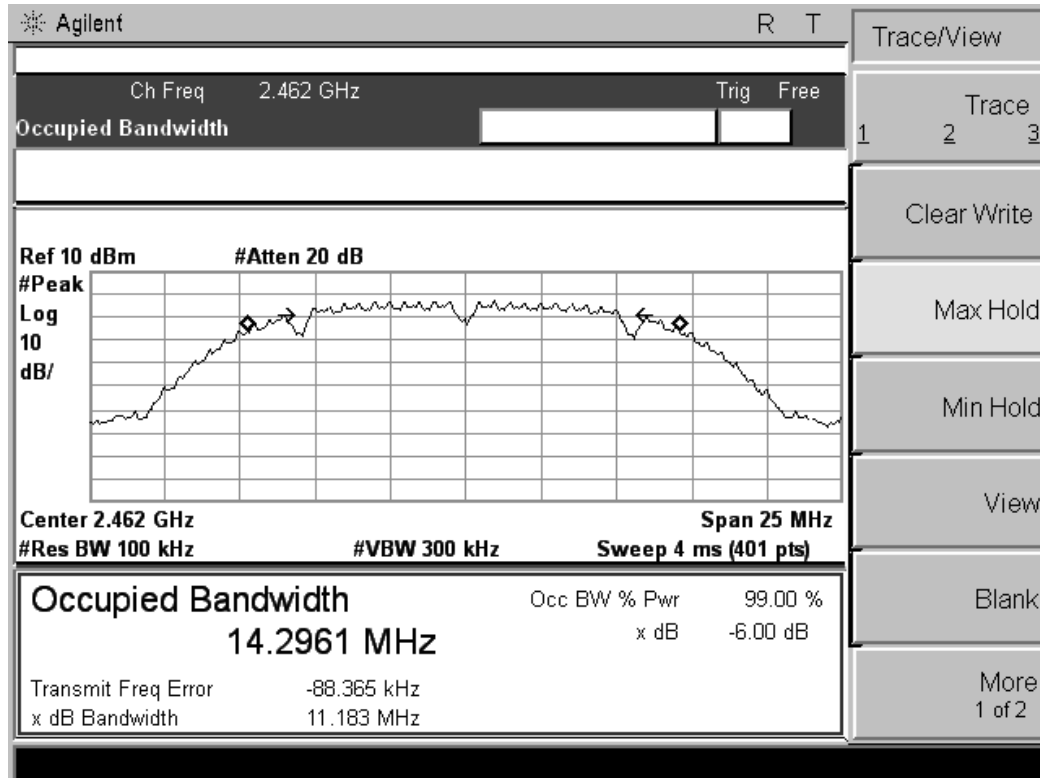

802.11g channel, 6dB bandwidth

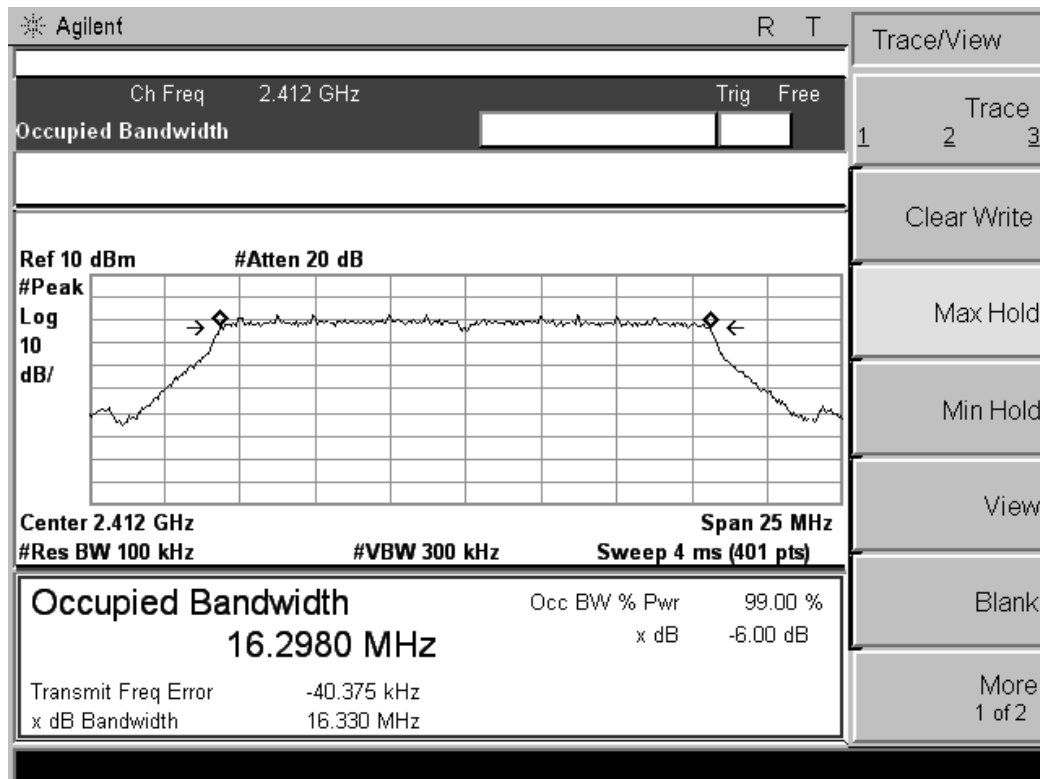

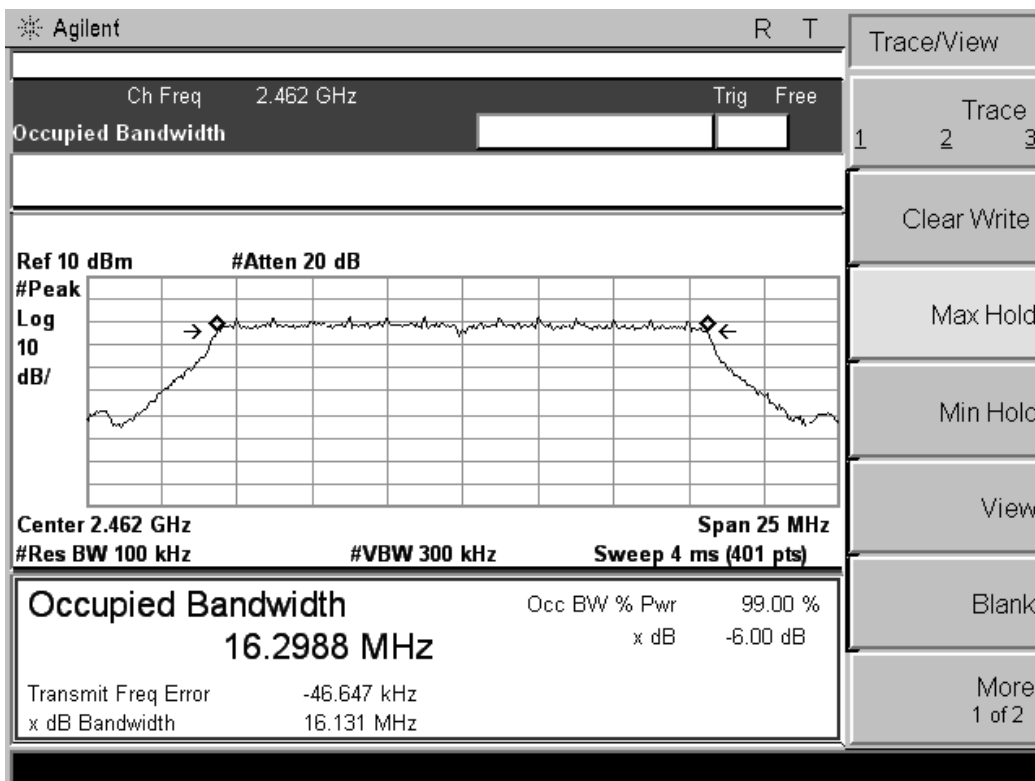
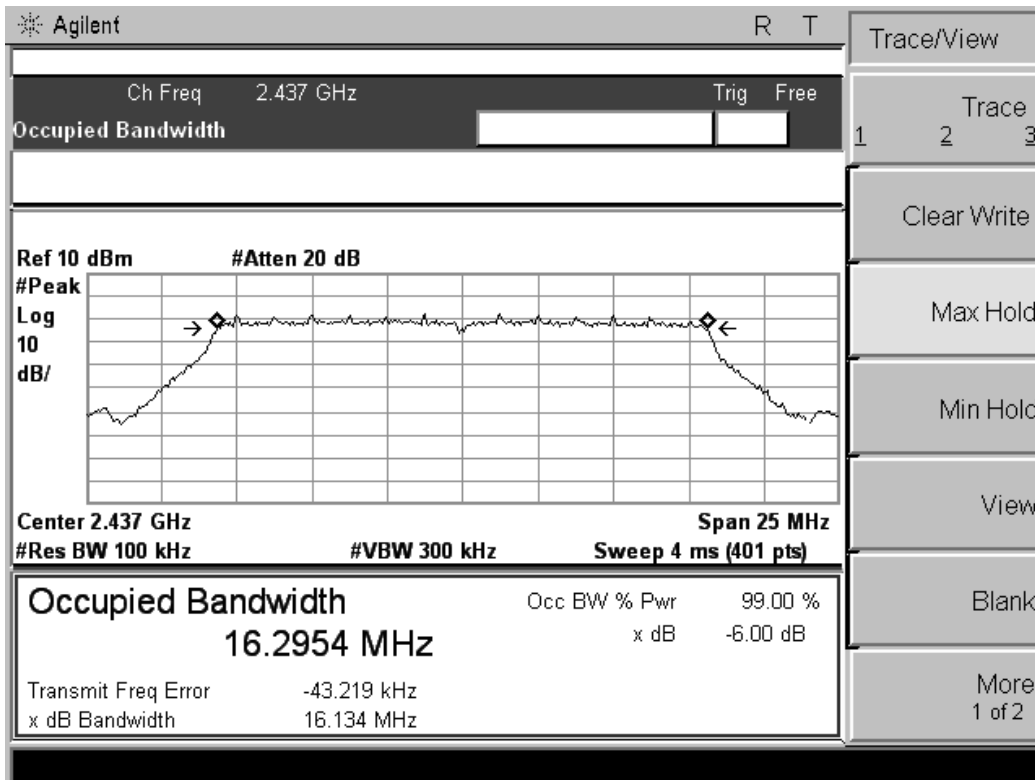

802.11n HT20 channel, 6dB bandwidth

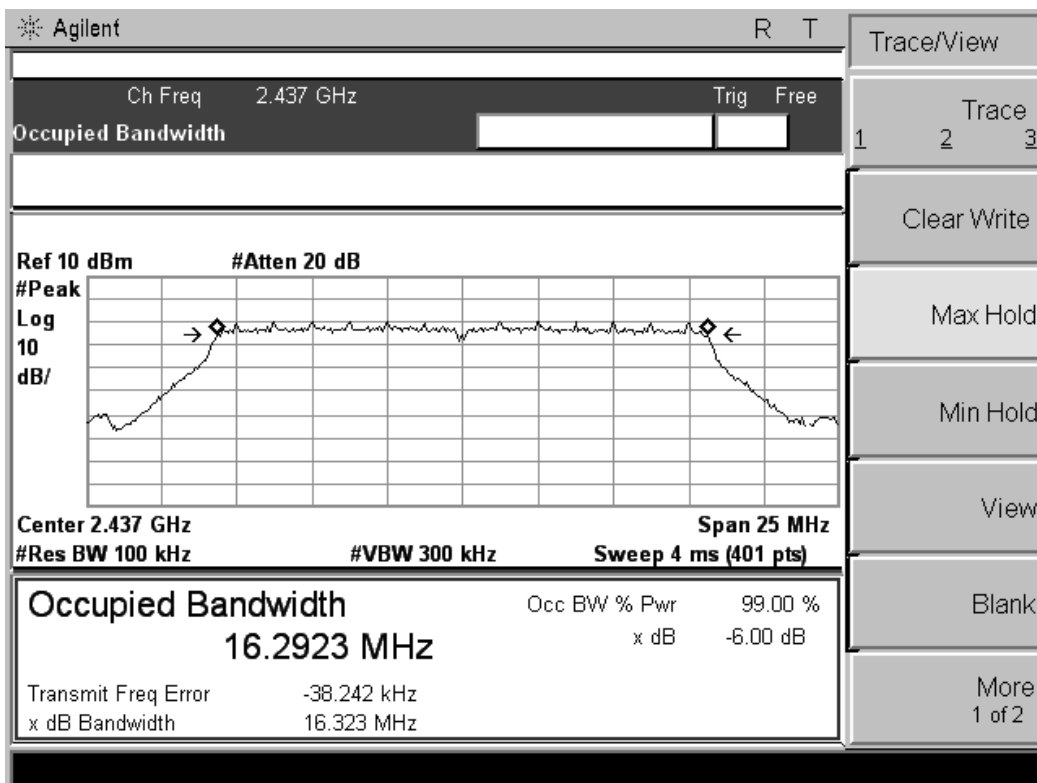
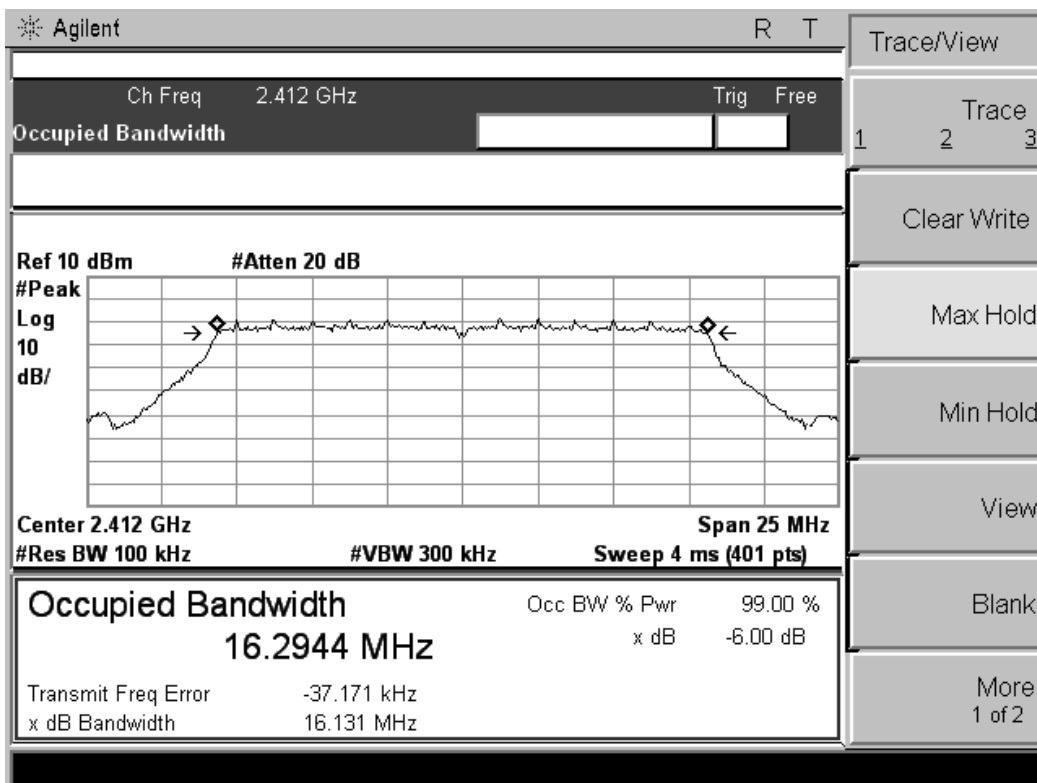

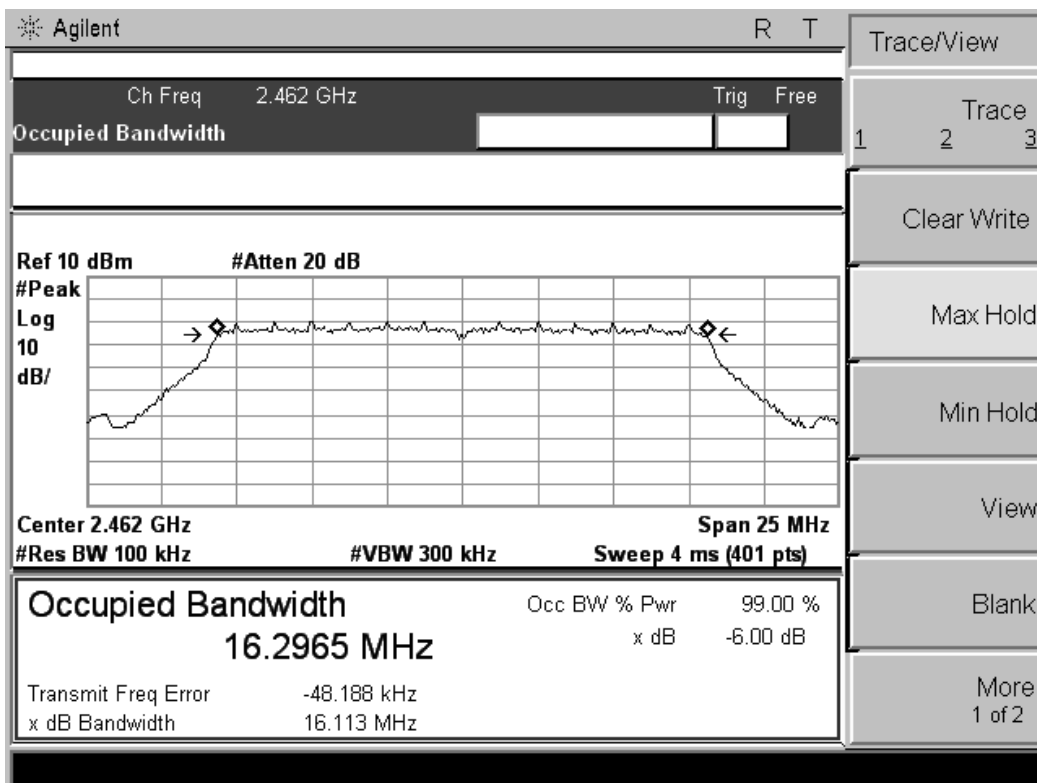

802.11n HT40 channel, 6dB bandwidth

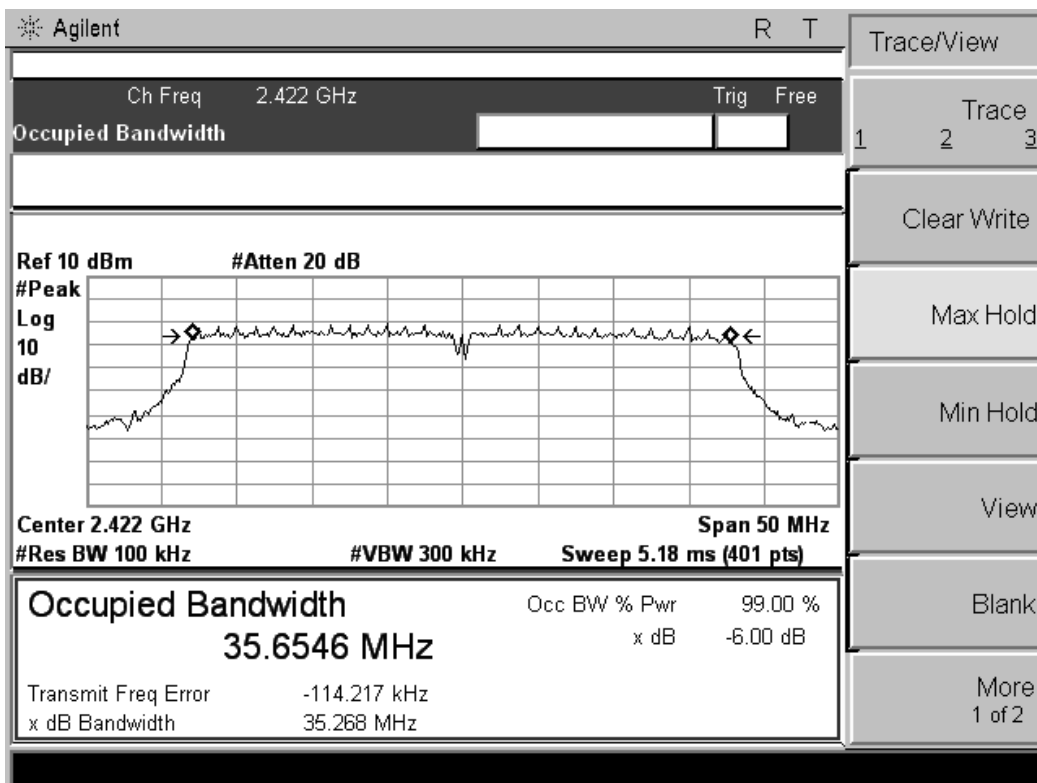

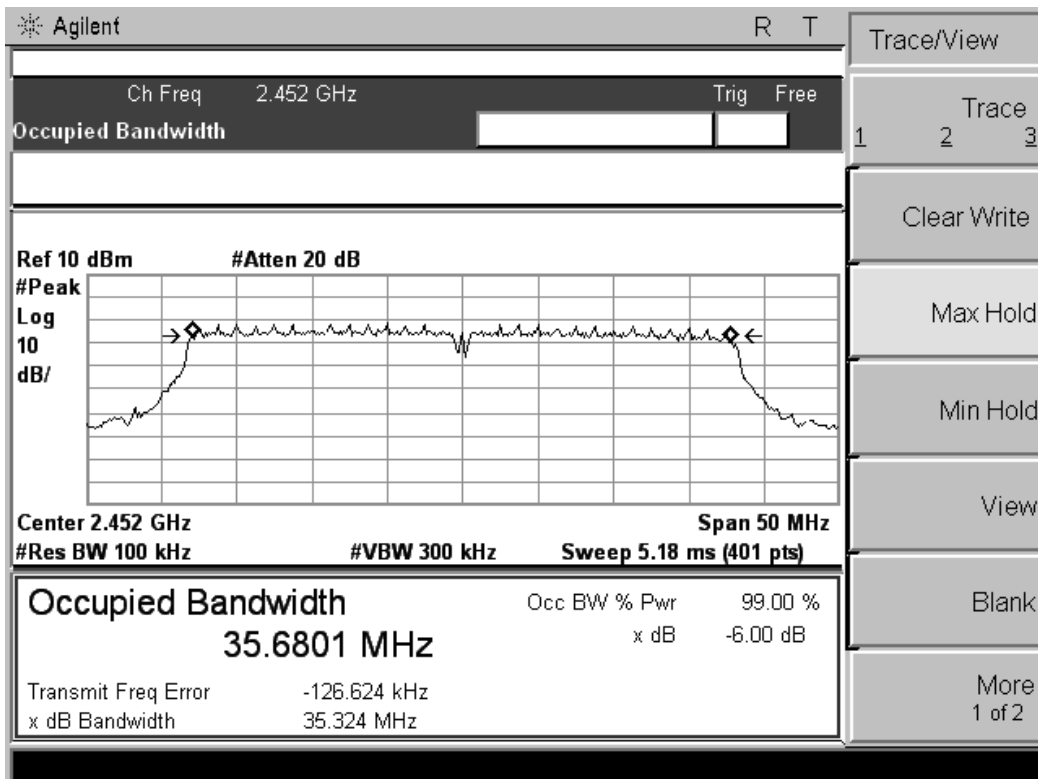
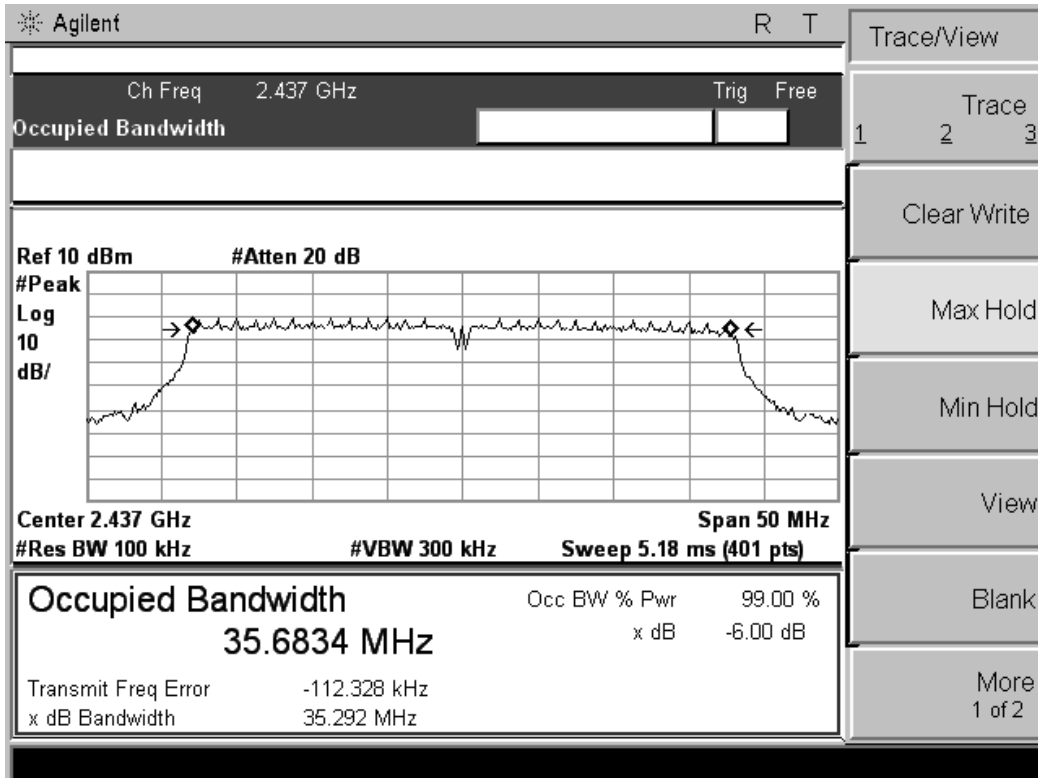

## 5.4. Occupied Bandwidth

### 5.4.1. Standard Applicable

According to §15.247(a) & A8.2(a): Operation under the provisions of this section is limited to frequency hopping and digitally modulated intentional radiators that comply with the following provisions:

For systems using digital modulation techniques, the EUT may operate in the 902-928 MHz, 2400-2483.5 MHz and 5725-5850 MHz bands. The minimum 6dB bandwidth shall be at least 500 kHz.

### 5.4.2. Measuring Instruments and Setting

Please refer to section 6 of equipments list in this report. The following table is the setting of the Spectrum Analyzer.

| Spectrum Parameter | Setting              |
|--------------------|----------------------|
| Attenuation        | Auto                 |
| Span Frequency     | > RBW                |
| RBW                | 1% to 3% of the band |
| VBW                | 3 times the RBW      |
| Detector           | Peak                 |
| Trace              | Max Hold             |
| Sweep Time         | 100ms                |

### 5

### 5.4.3. Test Procedures

The transmitter output is connected to the spectrum analyzer. The RBW is set to 1% to 3% of the bandwidth. The VBW is set to 3 times the RBW. The sweep time is coupled. The spectrum analyzer internal bandwidth measurement function is utilized.

### 5.4.4. Test Setup Layout

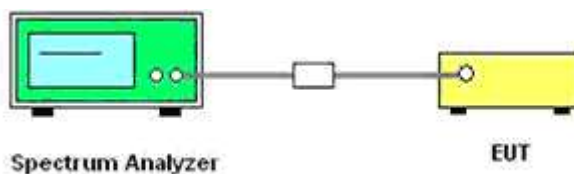

### 5.4.5. EUT Operation during Test

The EUT was programmed to be in continuously transmitting mode.

5.4.6. Test Result of 99% Occupied Bandwidth.

|               |      |                |             |
|---------------|------|----------------|-------------|
| Temperature   | 25°C | Humidity       | 60%         |
| Test Engineer | Tree | Configurations | 802.11b/g/n |

802.11b

| Channel | Frequency (MHz) | 99% OBW (MHz) |
|---------|-----------------|---------------|
| 1       | 2412            | 14.308        |
| 6       | 2437            | 14.305        |
| 11      | 2462            | 14.289        |

802.11g

| Channel | Frequency (MHz) | 99% OBW (MHz) |
|---------|-----------------|---------------|
| 1       | 2412            | 16.300        |
| 6       | 2437            | 16.298        |
| 11      | 2462            | 16.295        |

802.11n HT20

| Channel | Frequency (MHz) | 99% OBW (MHz) |
|---------|-----------------|---------------|
| 1       | 2412            | 16.289        |
| 6       | 2437            | 16.291        |
| 11      | 2462            | 16.305        |

802.11n HT40

| Channel | Frequency (MHz) | 99% OBW (MHz) |
|---------|-----------------|---------------|
| 3       | 2422            | 35.675        |
| 6       | 2437            | 35.656        |
| 9       | 2452            | 35.662        |

802.11b channel, 99% Occupied Bandwidth

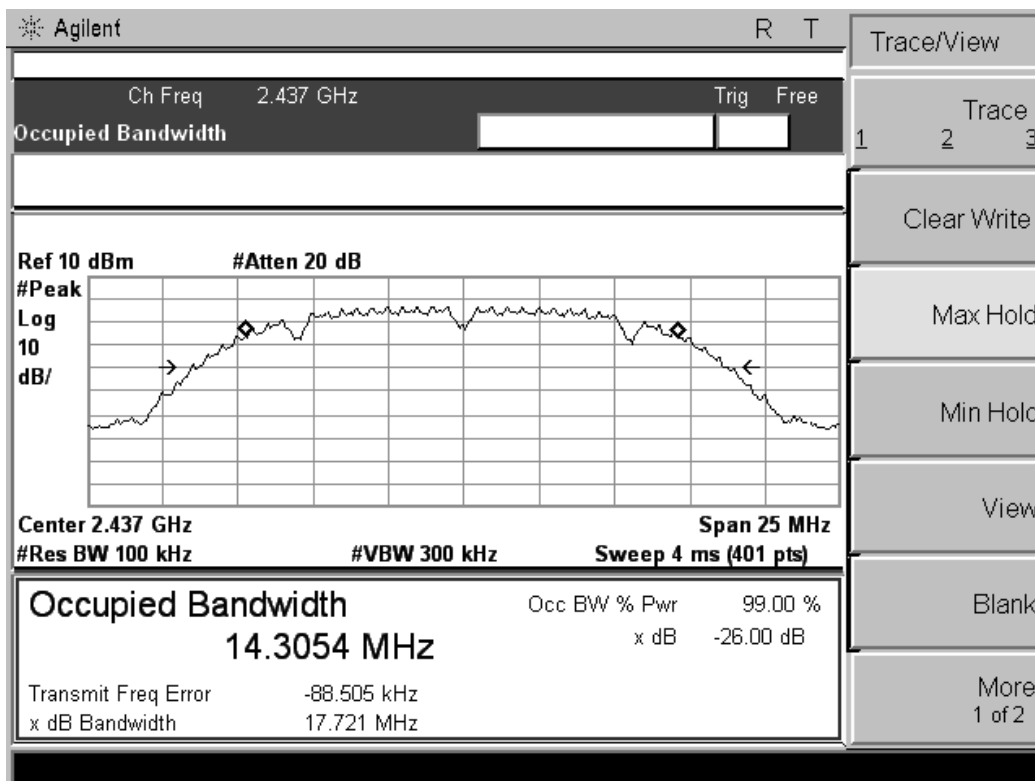
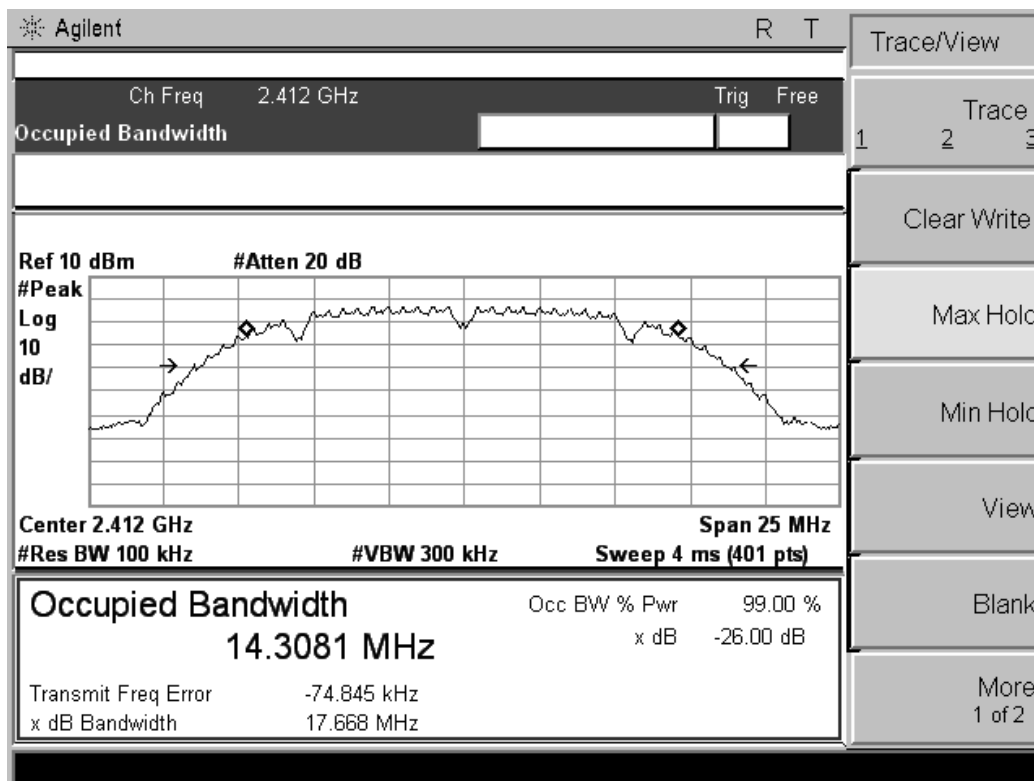



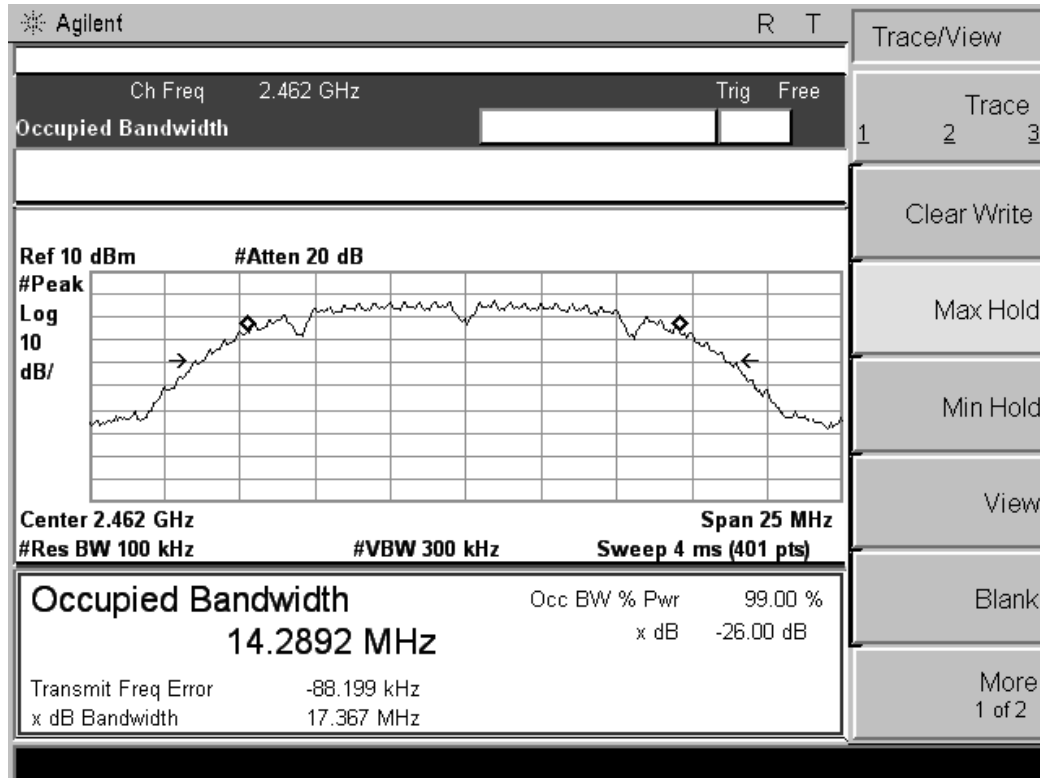

802.11g channel, 99% Occupied Bandwidth

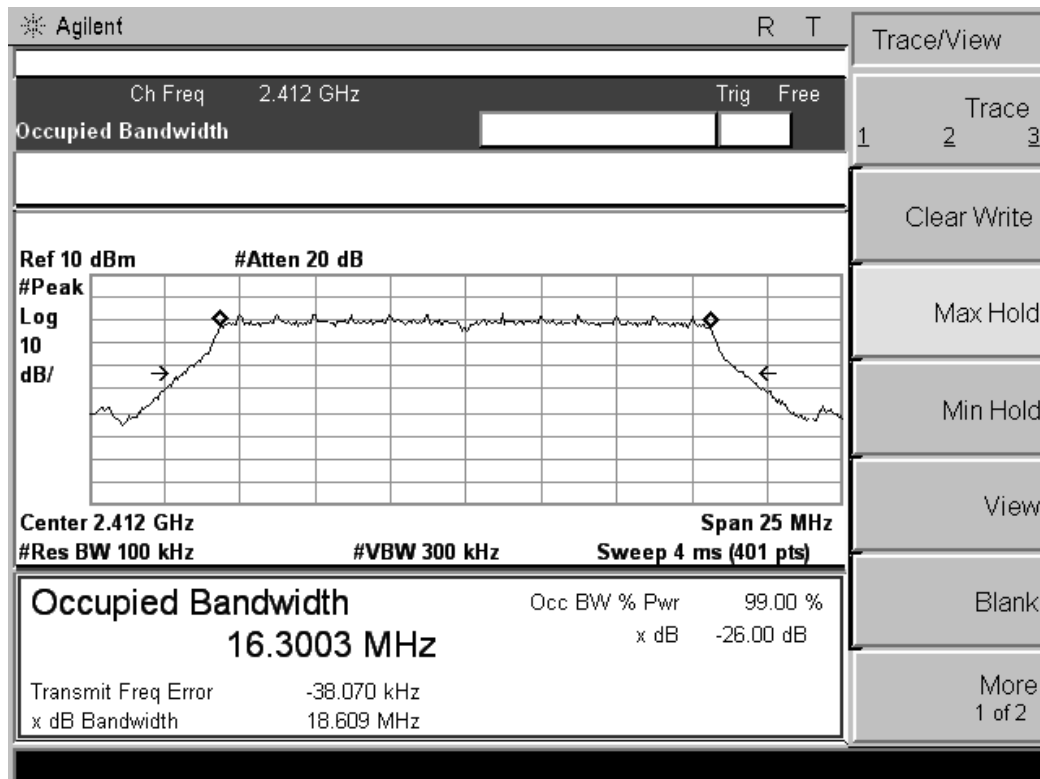

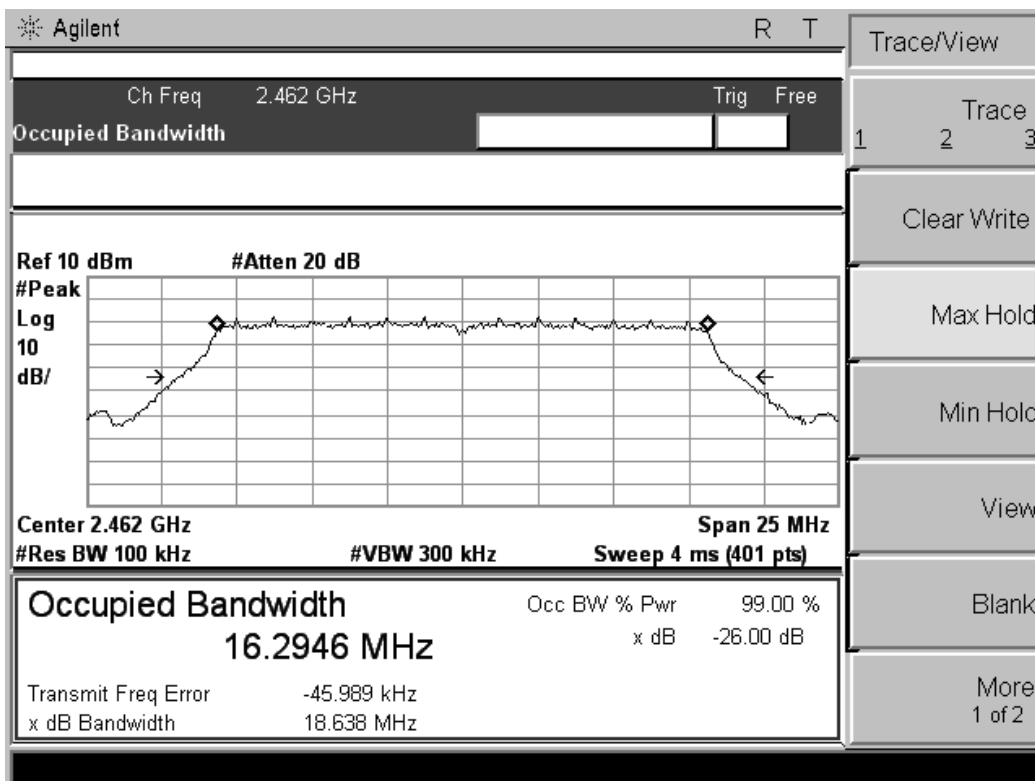
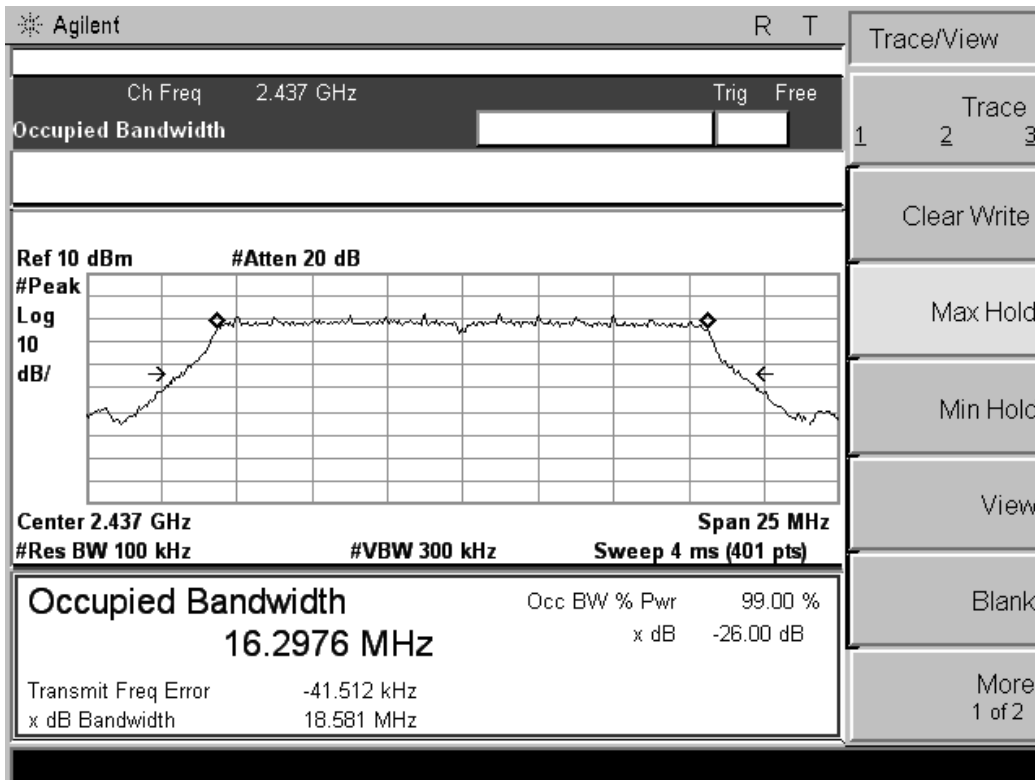

802.11n HT20 channel, 99% Occupied Bandwidth

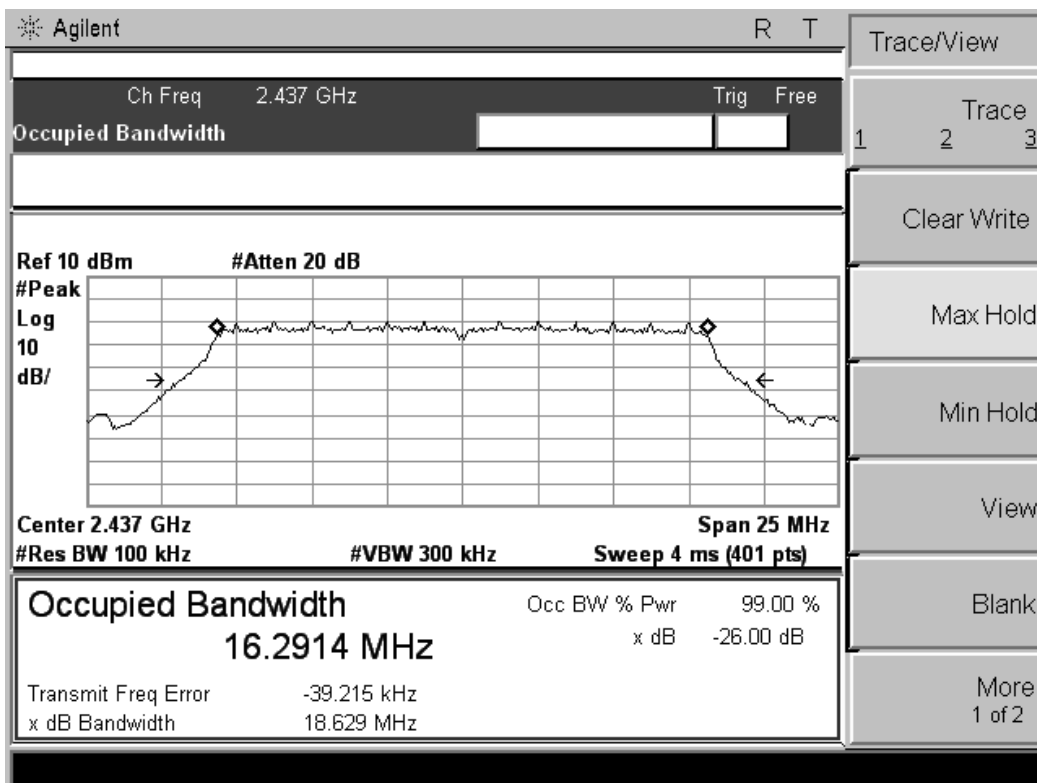
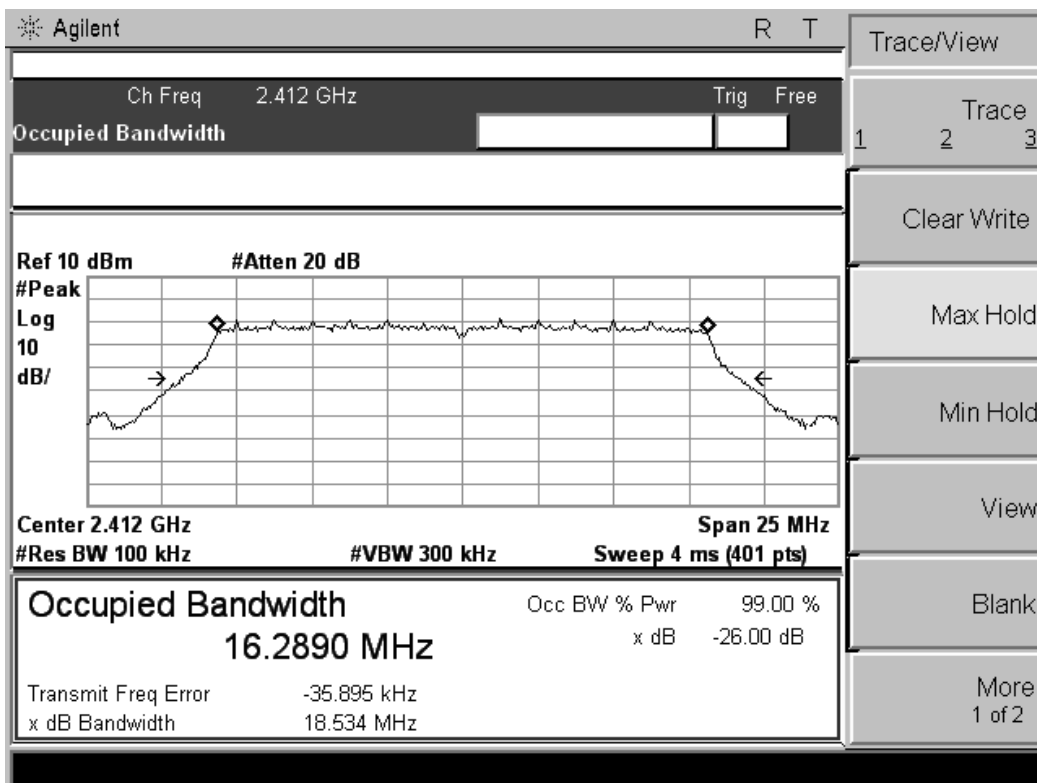

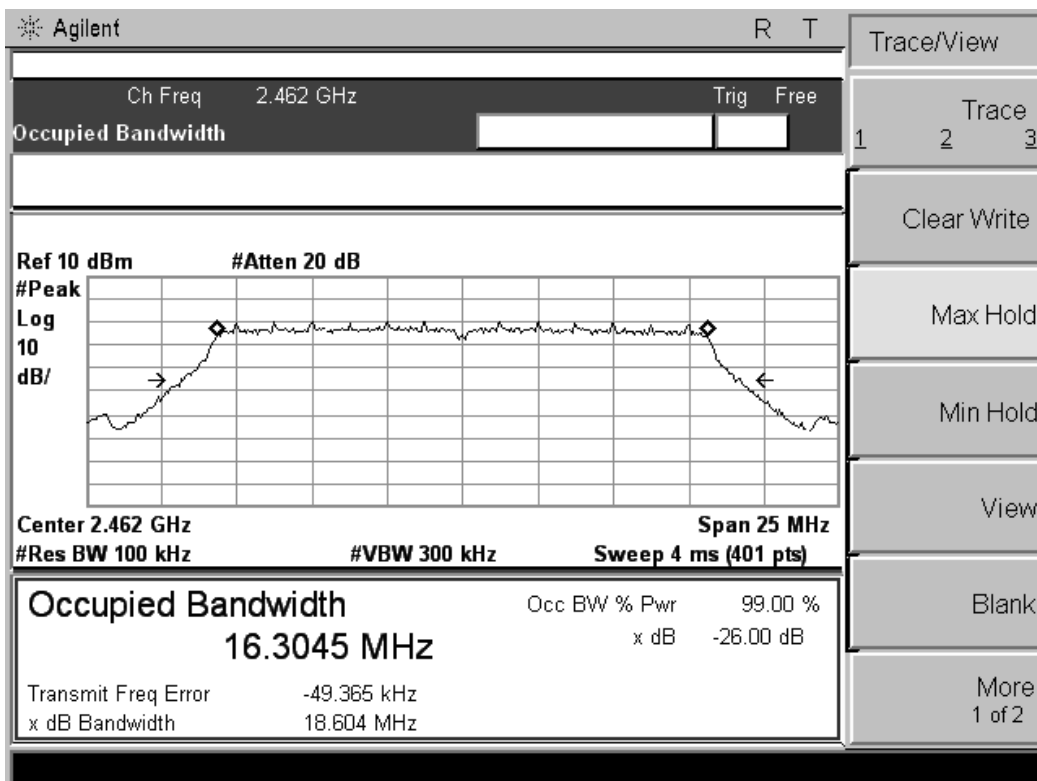

802.11n HT40 channel, 99% Occupied Bandwidth

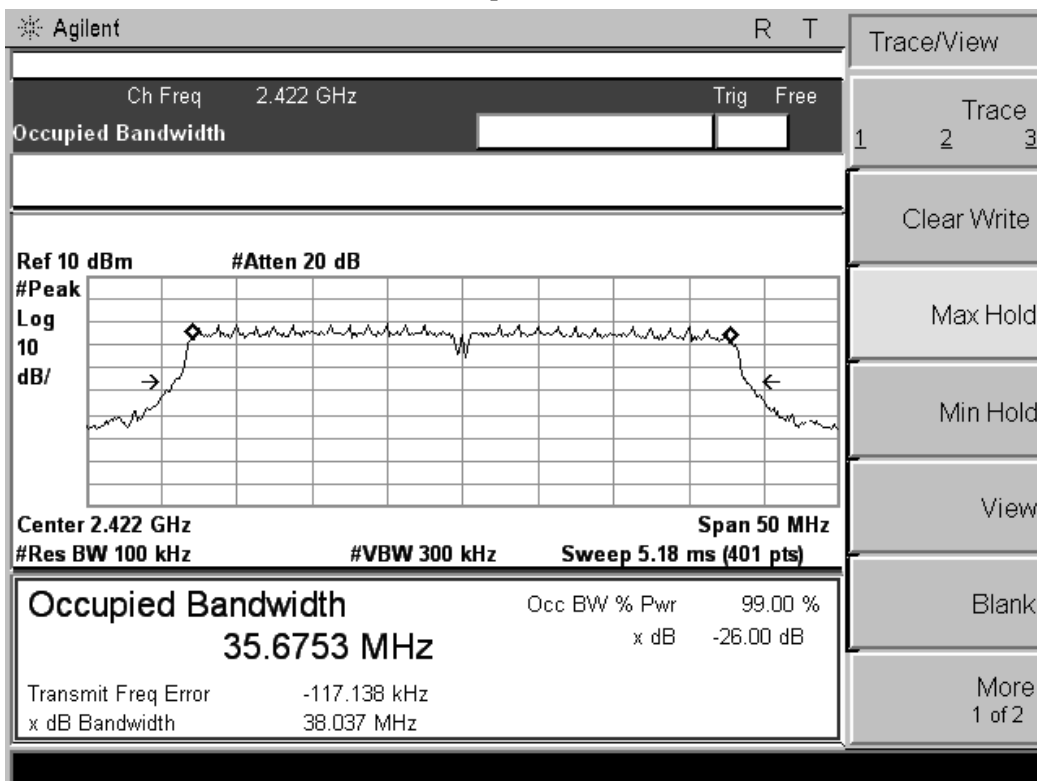

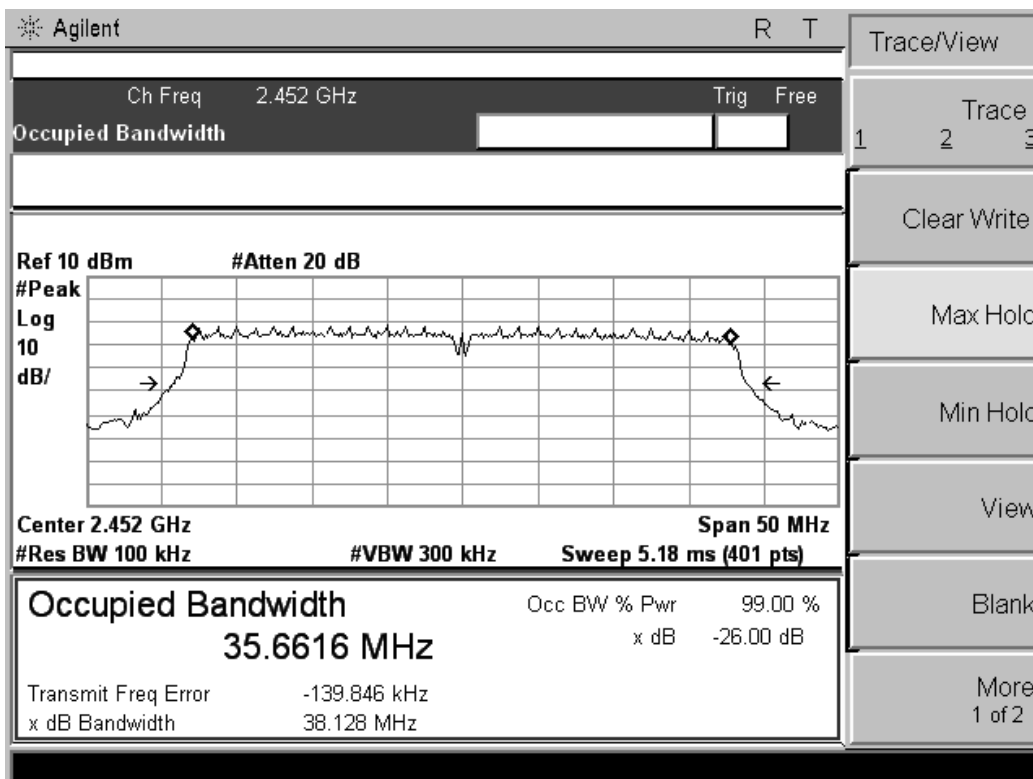
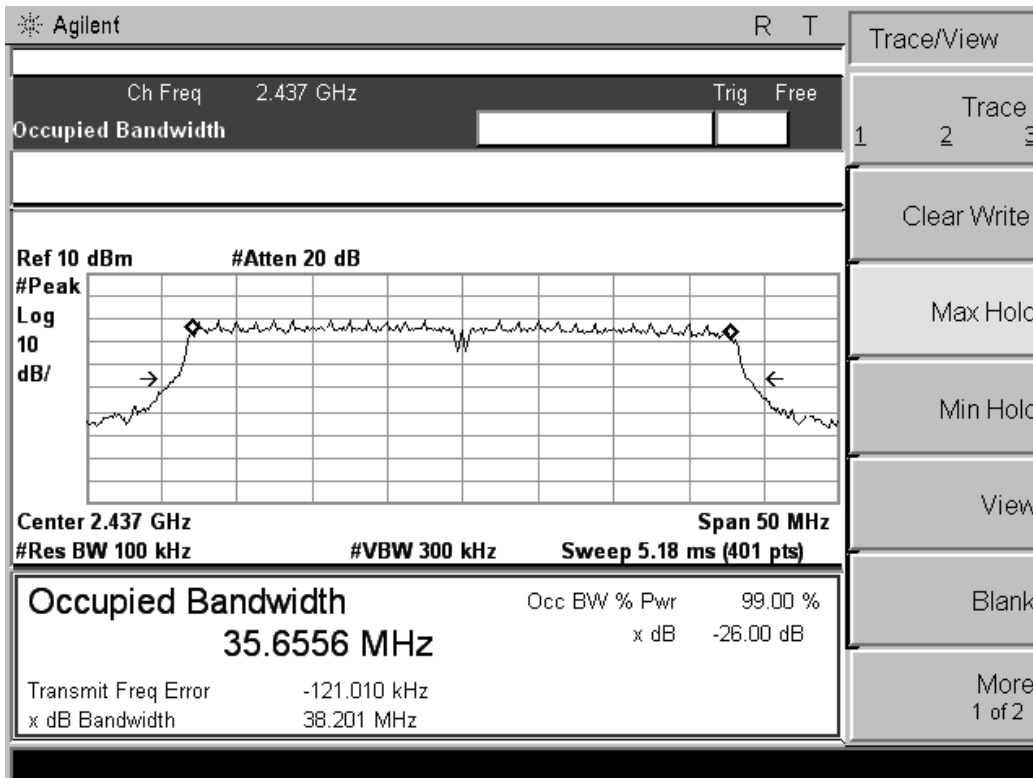

## 5.5. Radiated Emissions Measurement

### 5.5.1. Standard Applicable

According to §15.247 (d) & A8.5: 20dBc in any 100 kHz bandwidth outside the operating frequency band. In case the emission fall within the restricted band specified on 15.205(a), then the 15.209(a) limit in the table below has to be followed.

| Frequencies(MHz) | Field Strength(microvolts/meter) | Measurement Distance(meters) |
|------------------|----------------------------------|------------------------------|
| 0.009~0.490      | 2400/F(KHz)                      | 300                          |
| 0.490~1.705      | 24000/F(KHz)                     | 30                           |
| 1.705~30.0       | 30                               | 30                           |
| 30~88            | 100                              | 3                            |
| 88~216           | 150                              | 3                            |
| 216~960          | 200                              | 3                            |
| Above 960        | 500                              | 3                            |

### 5.5.2. Measuring Instruments and Setting

Please refer to section 6 of equipments list in this report. The following table is the setting of spectrum analyzer and receiver.

| Spectrum Parameter                        | Setting  |
|---|--|
| Attenuation                               | Auto   |
| Start Frequency                           | 1000 MHz                                       |
| Stop Frequency                            | 10th carrier harmonic                          |
| RB / VB (Emission in restricted band)     | 1MHz / 1MHz for Peak, 1 MHz / 10Hz for Average |
| RB / VB (Emission in non-restricted band) | 1MHz / 1MHz for Peak, 1 MHz / 10Hz for Average |

| Receiver Parameter     | Setting                          |
|------------------------|----------------------------------|
| Attenuation            | Auto                             |
| Start ~ Stop Frequency | 9kHz~150kHz / RB 200Hz for QP    |
| Start ~ Stop Frequency | 150kHz~30MHz / RB 9kHz for QP    |
| Start ~ Stop Frequency | 30MHz~1000MHz / RB 100kHz for QP |

### 5.5.3. Test Procedures

1. Configure the EUT according to ANSI C63.4. The EUT was placed on the top of the turntable 0.8 meter above ground. The phase center of the receiving antenna mounted on the top of a height-variable antenna tower was placed 3 meters far away from the turntable.
2. Power on the EUT and all the supporting units. The turntable was rotated by 360 degrees to determine the position of the highest radiation.
3. The height of the broadband receiving antenna was varied between one meter and four meters above ground to find the maximum emissions field strength of both horizontal and vertical polarization.

4. For each suspected emissions, the antenna tower was scan (from 1 m to 4 m) and then the turntable was rotated (from 0 degree to 360 degrees) to find the maximum reading
5. Set the test-receiver system to Peak or CISPR quasi-peak Detect Function with specified bandwidth under Maximum Hold Mode.
6. For emissions above 1GHz, use 1MHz VBW and RBW for peak reading. Then 1MHz RBW and 10Hz VBW for average reading in spectrum analyzer.
7. When the radiated emissions limits are expressed in terms of the average value of the emissions, and pulsed operation is employed, the measurement field strength shall be determined by averaging over one complete pulse train, including blanking intervals, as long as the pulse train does not exceed 0.1 seconds. As an alternative (provided the transmitter operates for longer than 0.1 seconds) or in cases where the pulse train exceeds 0.1 seconds, the measured field strength shall be determined from the average absolute voltage during a 0.1 second interval during which the field strength is at its maximum value.
8. If the emissions level of the EUT in peak mode was 3 dB lower than the average limit specified, then testing will be stopped and peak values of EUT will be reported, otherwise, the emissions which do not have 3 dB margin will be repeated one by one using the quasi-peak method for below 1GHz.
9. For testing above 1GHz, the emissions level of the EUT in peak mode was lower than average limit (that means the emissions level in peak mode also complies with the limit in average mode), then testing will be stopped and peak values of EUT will be reported, otherwise, the emissions will be measured in average mode again and reported.
10. In case the emission is lower than 30MHz, loop antenna has to be used for measurement and the recorded data should be QP measured by receiver. High – Low scan is not required in this case.

#### 5.5.4. Test Setup Layout

For radiated emissions below 30MHz

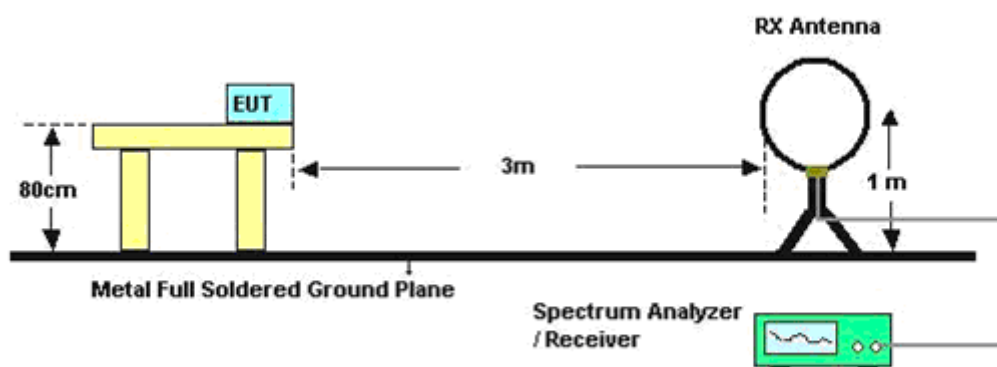

For radiated emissions above 30MHz

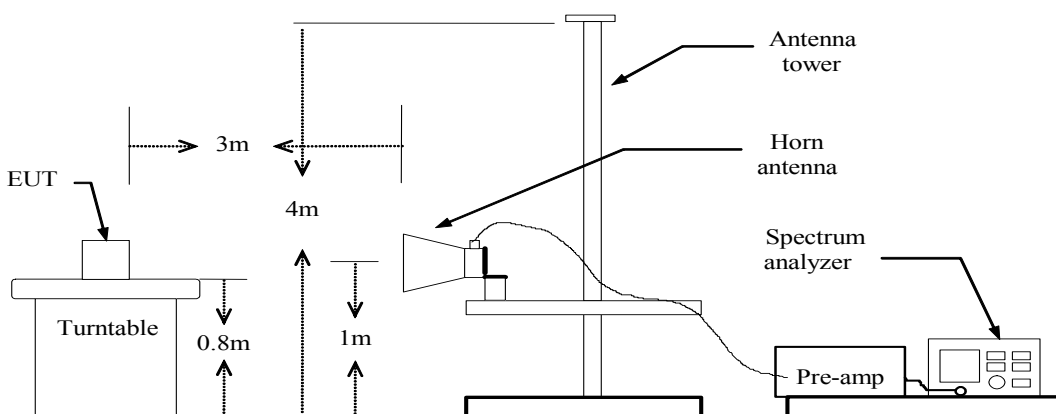
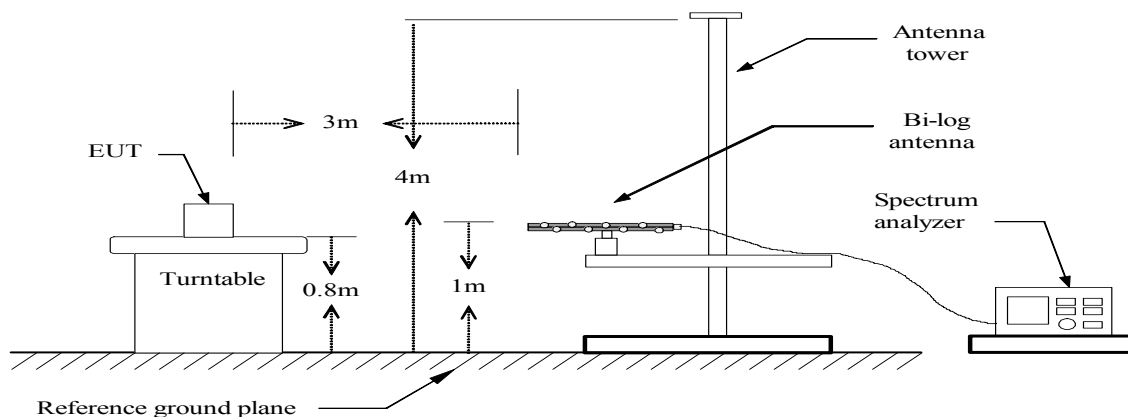

Above 10 GHz shall be extrapolated to the specified distance using an extrapolation factor of 20 dB/decade from 3m to 1.5m.

Distance extrapolation factor =  $20 \log (\text{specific distance [3m]} / \text{test distance [1.5m]})$  (dB);

Limit line = specific limits (dBuV) + distance extrapolation factor [6 dB].

5.5.5. EUT Operation during Test

The EUT was programmed to be in continuously transmitting mode.



5.5.6. Results of Radiated Emissions (9kHz~30MHz)

|               |      |                |             |
|---------------|------|----------------|-------------|
| Temperature   | 25°C | Humidity       | 60%         |
| Test Engineer | Tree | Configurations | 802.11b/g/n |

| Freq. (MHz) | Level (dBuV) | Over Limit (dB) | Over Limit (dBuV) | Remark   |
|-------------|--------------|-----------------|-------------------|----------|
| -           | -            | -               | -                 | See Note |

Note:

The amplitude of spurious emissions which are attenuated by more than 20 dB below the permissible value has no need to be reported.

Distance extrapolation factor = 40 log (specific distance / test distance) (dB);

Limit line = specific limits (dBuV) + distance extrapolation factor.

5.5.7. Results of Radiated Emissions (30MHz~1GHz)

|               |      |                |                  |
|---------------|------|----------------|------------------|
| Temperature   | 25°C | Humidity       | 60%              |
| Test Engineer | Tree | Configurations | 802.11b (Low CH) |

Test result for 802.11b (Low Channel)

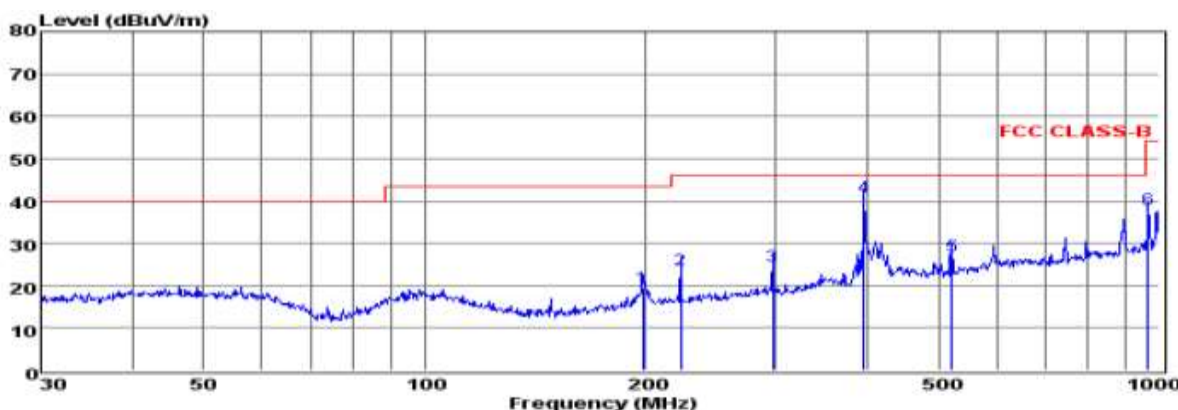

```

Env./Ins:      24°C/568
EUT:           Tablet PC
M/N:           HS-10DTB8
Power Rating:  DC 3.7V
Test Mode:     TX-2412(802.11b)
Operator:      Tree
Memo:
pol:           VERTICAL
    
```

|   | Freq   | Reading | CabLos | Antfac | Measured | Limit  | Over   | Remark |
|---|--------|---------|--------|--------|----------|--------|--------|--------|
|   | MHz    | dBuV    | dB     | dB/m   | dBuV/m   | dBuV/m | dB     |        |
| 1 | 197.89 | 8.27    | 0.84   | 10.57  | 19.68    | 43.50  | -23.82 | QP     |
| 2 | 222.95 | 11.63   | 0.95   | 11.33  | 23.91    | 46.00  | -22.09 | QP     |
| 3 | 297.22 | 10.52   | 1.12   | 13.01  | 24.65    | 46.00  | -21.35 | QP     |
| 4 | 396.24 | 24.70   | 1.30   | 14.97  | 40.97    | 46.00  | -5.03  | QP     |
| 5 | 520.89 | 8.48    | 1.47   | 16.97  | 26.92    | 46.00  | -19.08 | QP     |
| 6 | 965.54 | 14.52   | 1.88   | 21.52  | 37.92    | 54.00  | -16.08 | QP     |

Note: 1. All readings are Quasi-peak values.  
 2. Measured= Reading + Antenna Factor + Cable Loss  
 3. The emission that are 20db below the official limit are not reported

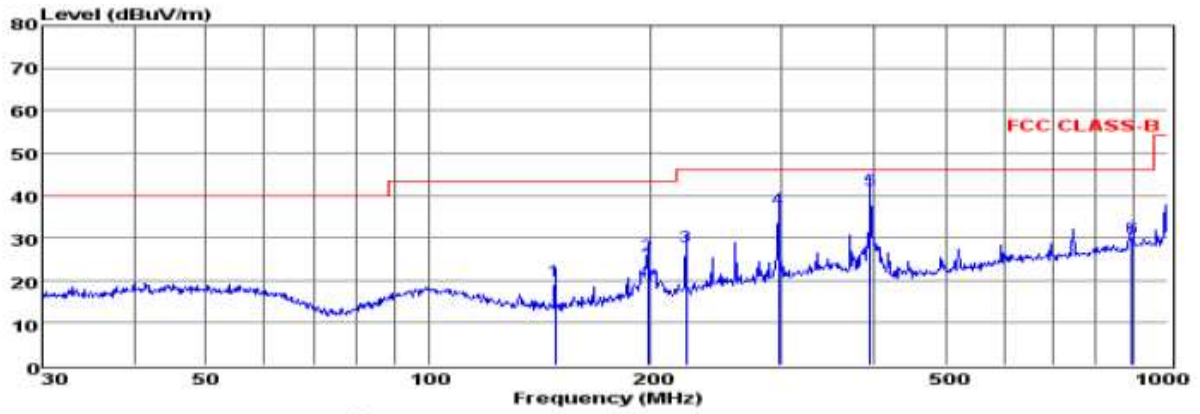

Env./Ins: 24 °C / 56%  
 EUT: Tablet PC  
 M/N: HS-10DTB8  
 Power Rating: DC 3.7V  
 Test Mode: TX-2412 (802.11b)  
 Operator: Tree  
 Memo:  
 pol: HORIZONTAL

|   | Freq   | Reading | CabLos | Antfac | Measured | Limit  | Over   | Remark |
|---|--------|---------|--------|--------|----------|--------|--------|--------|
|   | MHz    | dBuV    | dB     | dB/m   | dBuV/m   | dBuV/m | dB     |        |
| 1 | 148.44 | 10.75   | 0.86   | 8.25   | 19.86    | 43.50  | -23.64 | QP     |
| 2 | 197.89 | 14.41   | 0.84   | 10.57  | 25.82    | 43.50  | -17.68 | QP     |
| 3 | 222.95 | 15.78   | 0.95   | 11.33  | 28.06    | 46.00  | -17.94 | QP     |
| 4 | 297.22 | 22.61   | 1.12   | 13.01  | 36.74    | 46.00  | -9.26  | QP     |
| 5 | 396.24 | 25.01   | 1.30   | 14.97  | 41.28    | 46.00  | -4.72  | QP     |
| 6 | 893.86 | 7.18    | 1.84   | 21.03  | 30.05    | 46.00  | -15.95 | QP     |

Note: 1. All readings are Quasi-peak values.  
 2. Measured = Reading + Antenna Factor + Cable Loss  
 3. The emission that are 20db below the official limit are not reported

Note:

Pre-scan all mode and recorded the worst case results in this report (802.11b (Low Channel)).

Emission level (dBuV/m) = 20 log Emission level (uV/m).

Corrected Reading: Antenna Factor + Cable Loss + Read Level - Preamp Factor = Level.

## 5.5.8. Results for Radiated Emissions (Above 1GHz)

802.11b

Channel 1

| Freq. MHz | Reading dBuv | Ant. Fac. dB/m | Pre. Fac. dB | Cab. Loss dB | Measured dBuv/m | Limit dBuv/m | Margin dB | Remark  | Pol.       |
|-----------|--------------|----------------|--------------|--------------|-----------------|--------------|-----------|---------|------------|
| 4824.11   | 52.93        | 33.06          | 35.04        | 3.94         | 54.89           | 74           | -19.11    | Peak    | Horizontal |
| 4824.13   | 42.61        | 33.06          | 35.04        | 3.94         | 44.57           | 54           | -9.43     | Average | Horizontal |
| 4824.11   | 53.47        | 33.06          | 35.04        | 3.94         | 55.43           | 74           | -18.57    | Peak    | Vertical   |
| 4824.14   | 42.93        | 33.06          | 35.04        | 3.94         | 44.89           | 54           | -9.11     | Average | Vertical   |

Channel 6

| Freq. MHz | Reading dBuv | Ant. Fac. dB/m | Pre. Fac. dB | Cab. Loss dB | Measured dBuv/m | Limit dBuv/m | Margin dB | Remark  | Pol.       |
|-----------|--------------|----------------|--------------|--------------|-----------------|--------------|-----------|---------|------------|
| 4874.17   | 51.74        | 33.16          | 35.15        | 3.96         | 53.71           | 74           | -20.29    | Peak    | Horizontal |
| 4874.21   | 40.89        | 33.16          | 35.15        | 3.96         | 42.86           | 54           | -11.14    | Average | Horizontal |
| 4874.17   | 52.18        | 33.16          | 35.15        | 3.96         | 54.15           | 74           | -19.85    | Peak    | Vertical   |
| 4874.20   | 41.47        | 33.16          | 35.15        | 3.96         | 43.44           | 54           | -10.56    | Average | Vertical   |

Channel 11

| Freq. MHz | Reading dBuv | Ant. Fac. dB/m | Pre. Fac. dB | Cab. Loss dB | Measured dBuv/m | Limit dBuv/m | Margin dB | Remark  | Pol.       |
|-----------|--------------|----------------|--------------|--------------|-----------------|--------------|-----------|---------|------------|
| 4924.19   | 50.75        | 33.26          | 35.14        | 3.98         | 52.85           | 74           | -21.15    | Peak    | Horizontal |
| 4924.23   | 40.47        | 33.26          | 35.14        | 3.98         | 42.57           | 54           | -11.43    | Average | Horizontal |
| 4924.19   | 51.91        | 33.26          | 35.14        | 3.98         | 54.01           | 74           | -19.99    | Peak    | Vertical   |
| 4924.23   | 41.23        | 33.26          | 35.14        | 3.98         | 43.33           | 54           | -10.67    | Average | Vertical   |

802.11g

Channel 1

| Freq. MHz | Reading dBuv | Ant. Fac. dB/m | Pre. Fac. dB | Cab. Loss dB | Measured dBuv/m | Limit dBuv/m | Margin dB | Remark  | Pol.       |
|-----------|--------------|----------------|--------------|--------------|-----------------|--------------|-----------|---------|------------|
| 4824.41   | 51.89        | 33.06          | 35.04        | 3.94         | 53.85           | 74           | -20.15    | Peak    | Horizontal |
| 4824.45   | 40.76        | 33.06          | 35.04        | 3.94         | 42.72           | 54           | -11.28    | Average | Horizontal |
| 4824.43   | 52.55        | 33.06          | 35.04        | 3.94         | 54.51           | 74           | -19.49    | Peak    | Vertical   |
| 4824.46   | 41.39        | 33.06          | 35.04        | 3.94         | 43.35           | 54           | -10.65    | Average | Vertical   |

Channel 6

| Freq. MHz | Reading dBuv | Ant. Fac. dB/m | Pre. Fac. dB | Cab. Loss dB | Measured dBuv/m | Limit dBuv/m | Margin dB | Remark  | Pol.       |
|-----------|--------------|----------------|--------------|--------------|-----------------|--------------|-----------|---------|------------|
| 4874.27   | 50.71        | 33.16          | 35.15        | 3.96         | 52.68           | 74           | -21.32    | Peak    | Horizontal |
| 4874.31   | 39.64        | 33.16          | 35.15        | 3.96         | 41.61           | 54           | -12.39    | Average | Horizontal |
| 4874.29   | 51.62        | 33.16          | 35.15        | 3.96         | 53.59           | 74           | -20.41    | Peak    | Vertical   |
| 4874.32   | 40.35        | 33.16          | 35.15        | 3.96         | 42.32           | 54           | -11.68    | Average | Vertical   |

Channel 11

| Freq. MHz | Reading dBuv | Ant. Fac. dB/m | Pre. Fac. dB | Cab. Loss dB | Measured dBuv/m | Limit dBuv/m | Margin dB | Remark  | Pol.       |
|-----------|--------------|----------------|--------------|--------------|-----------------|--------------|-----------|---------|------------|
| 4924.44   | 50.13        | 33.26          | 35.14        | 3.98         | 52.23           | 74           | -21.77    | Peak    | Horizontal |
| 4924.47   | 39.79        | 33.26          | 35.14        | 3.98         | 41.89           | 54           | -12.11    | Average | Horizontal |
| 4924.43   | 50.81        | 33.26          | 35.14        | 3.98         | 52.91           | 74           | -21.09    | Peak    | Vertical   |
| 4924.47   | 40.52        | 33.26          | 35.14        | 3.98         | 42.62           | 54           | -11.38    | Average | Vertical   |

802.11n HT20

Channel 1

| Freq. MHz | Reading dBuv | Ant. Fac. dB/m | Pre. Fac. dB | Cab. Loss dB | Measured dBuv/m | Limit dBuv/m | Margin dB | Remark  | Pol.       |
|-----------|--------------|----------------|--------------|--------------|-----------------|--------------|-----------|---------|------------|
| 4824.57   | 48.87        | 33.06          | 35.04        | 3.94         | 50.83           | 74           | -23.17    | Peak    | Horizontal |
| 4824.61   | 38.94        | 33.06          | 35.04        | 3.94         | 40.90           | 54           | -13.10    | Average | Horizontal |
| 4824.57   | 49.33        | 33.06          | 35.04        | 3.94         | 51.29           | 74           | -22.71    | Peak    | Vertical   |
| 4824.60   | 39.41        | 33.06          | 35.04        | 3.94         | 41.37           | 54           | -12.63    | Average | Vertical   |

Channel 6

| Freq. MHz | Reading dBuv | Ant. Fac. dB/m | Pre. Fac. dB | Cab. Loss dB | Measure d dBuv/m | Limit dBuv/m | Margin dB | Remark  | Pol.       |
|-----------|--------------|----------------|--------------|--------------|------------------|--------------|-----------|---------|------------|
| 4874.37   | 47.61        | 33.16          | 35.15        | 3.96         | 49.58            | 74           | -24.42    | Peak    | Horizontal |
| 4874.39   | 37.73        | 33.16          | 35.15        | 3.96         | 39.70            | 54           | -14.30    | Average | Horizontal |
| 4874.36   | 48.83        | 33.16          | 35.15        | 3.96         | 50.80            | 74           | -23.20    | Peak    | Vertical   |
| 4874.39   | 38.89        | 33.16          | 35.15        | 3.96         | 40.86            | 54           | -13.14    | Average | Vertical   |

Channel 11

| Freq. MHz | Reading dBuv | Ant. Fac. dB/m | Pre. Fac. dB | Cab. Loss dB | Measured dBuv/m | Limit dBuv/m | Margin dB | Remark  | Pol.       |
|-----------|--------------|----------------|--------------|--------------|-----------------|--------------|-----------|---------|------------|
| 4924.43   | 47.15        | 33.26          | 35.14        | 3.98         | 49.25           | 74           | -24.75    | Peak    | Horizontal |
| 4924.47   | 37.46        | 33.26          | 35.14        | 3.98         | 39.56           | 54           | -14.44    | Average | Horizontal |
| 4924.43   | 47.96        | 33.26          | 35.14        | 3.98         | 50.06           | 74           | -23.94    | Peak    | Vertical   |
| 4924.48   | 37.84        | 33.26          | 35.14        | 3.98         | 39.94           | 54           | -14.06    | Average | Vertical   |

## 802.11n HT40

## Channel 3

| Freq. MHz | Reading dBuV | Ant. Fac. dB/m | Pre. Fac. dB | Cab. Loss dB | Measured dBuV/m | Limit dBuV/m | Margin dB | Remark  | Pol.       |
|-----------|--------------|----------------|--------------|--------------|-----------------|--------------|-----------|---------|------------|
| 4844.51   | 46.11        | 33.06          | 35.04        | 3.94         | 48.07           | 74           | -25.93    | Peak    | Horizontal |
| 4844.54   | 36.97        | 33.06          | 35.04        | 3.94         | 38.93           | 54           | -15.07    | Average | Horizontal |
| 4844.51   | 46.58        | 33.06          | 35.04        | 3.94         | 48.54           | 74           | -25.46    | Peak    | Vertical   |
| 4844.54   | 37.34        | 33.06          | 35.04        | 3.94         | 39.30           | 54           | -14.70    | Average | Vertical   |

## Channel 6

| Freq. MHz | Reading dBuV | Ant. Fac. dB/m | Pre. Fac. dB | Cab. Loss dB | Measured dBuV/m | Limit dBuV/m | Margin dB | Remark  | Pol.       |
|-----------|--------------|----------------|--------------|--------------|-----------------|--------------|-----------|---------|------------|
| 4874.33   | 45.76        | 33.16          | 35.15        | 3.96         | 47.73           | 74           | -26.27    | Peak    | Horizontal |
| 4874.37   | 35.28        | 33.16          | 35.15        | 3.96         | 37.25           | 54           | -16.75    | Average | Horizontal |
| 4874.34   | 46.37        | 33.16          | 35.15        | 3.96         | 48.34           | 74           | -25.66    | Peak    | Vertical   |
| 4874.37   | 36.05        | 33.16          | 35.15        | 3.96         | 38.02           | 54           | -15.98    | Average | Vertical   |

## Channel 9

| Freq. MHz | Reading dBuV | Ant. Fac. dB/m | Pre. Fac. dB | Cab. Loss dB | Measured dBuV/m | Limit dBuV/m | Margin dB | Remark  | Pol.       |
|-----------|--------------|----------------|--------------|--------------|-----------------|--------------|-----------|---------|------------|
| 4904.57   | 45.13        | 33.26          | 35.14        | 3.98         | 47.23           | 74           | -26.77    | Peak    | Horizontal |
| 4904.61   | 35.34        | 33.26          | 35.14        | 3.98         | 37.44           | 54           | -16.56    | Average | Horizontal |
| 4904.56   | 45.96        | 33.26          | 35.14        | 3.98         | 48.06           | 74           | -25.94    | Peak    | Vertical   |
| 4904.61   | 35.87        | 33.26          | 35.14        | 3.98         | 37.97           | 54           | -16.03    | Average | Vertical   |

**Notes:**

1. Measuring frequencies from 9k~10th harmonic or 26.5GHz (which is less), No emission found between lowest internal used/generated frequency to 30MHz.
2. Radiated emissions measured in frequency range from 9k~10th harmonic or 40GHz (which is less) were made with an instrument using Peak detector mode.
3. Data of measurement within this frequency range shown " --- " in the table above means the reading of emissions are attenuated more than 20dB below the permissible limits or the field strength is too small to be measured.

## 5.5.9. Results of Band Edges Test (Radiated)

802.11b

Tx-2412

| Freq. MHz | Reading dBuV | Ant. Fac. dB/m | Pre. Fac. dB | Cab. Loss dB | Measured dBuV/m | Limit dBuV/m | Margin dB | Remark  | Pol.       |
|-----------|--------------|----------------|--------------|--------------|-----------------|--------------|-----------|---------|------------|
| 2361.78   | 44.85        | 32.89          | 35.16        | 3.51         | 46.09           | 74           | -27.91    | Peak    | Horizontal |
| 2361.81   | 35.67        | 32.90          | 35.16        | 3.51         | 36.92           | 54           | -17.08    | Average | Horizontal |
| 2400.00   | 49.16        | 32.92          | 35.16        | 3.54         | 50.46           | 74           | -23.54    | Peak    | Horizontal |
| 2399.99   | 37.23        | 32.92          | 35.16        | 3.54         | 38.53           | 54           | -15.47    | Average | Horizontal |
| 2361.86   | 45.11        | 32.89          | 35.16        | 3.51         | 46.35           | 74           | -27.65    | Peak    | Vertical   |
| 2361.89   | 34.89        | 32.90          | 35.16        | 3.51         | 36.14           | 54           | -17.86    | Average | Vertical   |
| 2400.00   | 48.75        | 32.92          | 35.16        | 3.54         | 50.05           | 74           | -23.95    | Peak    | Vertical   |
| 2399.99   | 37.12        | 32.92          | 35.16        | 3.54         | 38.42           | 54           | -15.58    | Average | Vertical   |

Tx-2462

| Freq. MHz | Reading dBuV | Ant. Fac. dB/m | Pre. Fac. dB | Cab. Loss dB | Measured dBuV/m | Limit dBuV/m | Margin dB | Remark  | Pol.       |
|-----------|--------------|----------------|--------------|--------------|-----------------|--------------|-----------|---------|------------|
| 2483.50   | 46.67        | 33.06          | 35.18        | 3.60         | 48.15           | 74           | -25.85    | Peak    | Horizontal |
| 2483.51   | 37.11        | 33.08          | 35.18        | 3.60         | 38.61           | 54           | -15.39    | Average | Horizontal |
| 2487.59   | 44.63        | 33.08          | 35.18        | 3.62         | 46.15           | 74           | -27.85    | Peak    | Horizontal |
| 2487.64   | 35.35        | 33.08          | 35.18        | 3.62         | 36.87           | 54           | -17.13    | Average | Horizontal |
| 2483.50   | 46.83        | 33.06          | 35.18        | 3.60         | 48.31           | 74           | -25.69    | Peak    | Vertical   |
| 2483.51   | 37.52        | 33.08          | 35.18        | 3.60         | 39.02           | 54           | -14.98    | Average | Vertical   |
| 2487.61   | 44.71        | 33.08          | 35.18        | 3.62         | 46.23           | 74           | -27.77    | Peak    | Vertical   |
| 2487.64   | 35.67        | 33.08          | 35.18        | 3.62         | 37.19           | 54           | -16.81    | Average | Vertical   |

802.11g

Tx-2412

| Freq. MHz | Reading dBuV | Ant. Fac. dB/m | Pre. Fac. dB | Cab. Loss dB | Measured dBuV/m | Limit dBuV/m | Margin dB | Remark  | Pol.       |
|-----------|--------------|----------------|--------------|--------------|-----------------|--------------|-----------|---------|------------|
| 2375.34   | 44.59        | 32.89          | 35.16        | 3.51         | 45.83           | 74           | -28.17    | Peak    | Horizontal |
| 2375.37   | 35.78        | 32.90          | 35.16        | 3.51         | 37.03           | 54           | -16.97    | Average | Horizontal |
| 2400.00   | 47.65        | 32.92          | 35.16        | 3.54         | 48.95           | 74           | -25.05    | Peak    | Horizontal |
| 2399.99   | 36.73        | 32.92          | 35.16        | 3.54         | 38.03           | 54           | -15.97    | Average | Horizontal |
| 2375.41   | 45.01        | 32.89          | 35.16        | 3.51         | 46.25           | 74           | -27.75    | Peak    | Vertical   |
| 2375.45   | 35.86        | 32.90          | 35.16        | 3.51         | 37.11           | 54           | -16.89    | Average | Vertical   |
| 2400.00   | 47.79        | 32.92          | 35.16        | 3.54         | 49.09           | 74           | -24.91    | Peak    | Vertical   |
| 2399.99   | 36.87        | 32.92          | 35.16        | 3.54         | 38.17           | 54           | -15.83    | Average | Vertical   |

Tx-2462

| Freq. MHz | Reading dBuV | Ant. Fac. dB/m | Pre. Fac. dB | Cab. Loss dB | Measured dBuV/m | Limit dBuV/m | Margin dB | Remark  | Pol.       |
|-----------|--------------|----------------|--------------|--------------|-----------------|--------------|-----------|---------|------------|
| 2483.50   | 46.48        | 33.06          | 35.18        | 3.60         | 47.96           | 74           | -26.04    | Peak    | Horizontal |
| 2483.51   | 36.32        | 33.08          | 35.18        | 3.60         | 37.82           | 54           | -16.18    | Average | Horizontal |
| 2490.11   | 44.21        | 33.08          | 35.18        | 3.62         | 45.73           | 74           | -28.27    | Peak    | Horizontal |
| 2490.13   | 34.46        | 33.08          | 35.18        | 3.62         | 35.98           | 54           | -18.02    | Average | Horizontal |
| 2483.50   | 46.65        | 33.06          | 35.18        | 3.60         | 48.13           | 74           | -25.87    | Peak    | Vertical   |
| 2483.51   | 36.74        | 33.08          | 35.18        | 3.60         | 38.24           | 54           | -15.76    | Average | Vertical   |
| 2489.97   | 44.45        | 33.08          | 35.18        | 3.62         | 45.97           | 74           | -28.03    | Peak    | Vertical   |
| 2490.01   | 34.39        | 33.08          | 35.18        | 3.62         | 35.91           | 54           | -18.09    | Average | Vertical   |



802.11n(HT20)

Tx-2412

| Freq. MHz | Reading dBuV | Ant. Fac. dB/m | Pre. Fac. dB | Cab. Loss dB | Measured dBuV/m | Limit dBuV/m | Margin dB | Remark  | Pol.       |
|-----------|--------------|----------------|--------------|--------------|-----------------|--------------|-----------|---------|------------|
| 2376.53   | 44.11        | 32.89          | 35.16        | 3.51         | 45.35           | 74           | -28.65    | Peak    | Horizontal |
| 2376.56   | 35.26        | 32.90          | 35.16        | 3.51         | 36.51           | 54           | -17.49    | Average | Horizontal |
| 2400.00   | 46.79        | 32.92          | 35.16        | 3.54         | 48.09           | 74           | -25.91    | Peak    | Horizontal |
| 2399.93   | 37.16        | 32.92          | 35.16        | 3.54         | 38.46           | 54           | -15.54    | Average | Horizontal |
| 2376.73   | 44.56        | 32.89          | 35.16        | 3.51         | 45.80           | 74           | -28.20    | Peak    | Vertical   |
| 2376.77   | 35.47        | 32.90          | 35.16        | 3.51         | 36.72           | 54           | -17.28    | Average | Vertical   |
| 2400.00   | 46.89        | 32.92          | 35.16        | 3.54         | 48.19           | 74           | -25.81    | Peak    | Vertical   |
| 2399.99   | 37.65        | 32.92          | 35.16        | 3.54         | 38.95           | 54           | -15.05    | Average | Vertical   |

Tx-2462

| Freq. MHz | Reading dBuV | Ant. Fac. dB/m | Pre. Fac. dB | Cab. Loss dB | Measured dBuV/m | Limit dBuV/m | Margin dB | Remark  | Pol.       |
|-----------|--------------|----------------|--------------|--------------|-----------------|--------------|-----------|---------|------------|
| 2483.50   | 45.73        | 33.06          | 35.18        | 3.60         | 47.21           | 74           | -26.79    | Peak    | Horizontal |
| 2483.51   | 35.61        | 33.08          | 35.18        | 3.60         | 37.11           | 54           | -16.89    | Average | Horizontal |
| 2488.97   | 44.32        | 33.08          | 35.18        | 3.62         | 45.84           | 74           | -28.16    | Peak    | Horizontal |
| 2489.02   | 34.64        | 33.08          | 35.18        | 3.62         | 36.16           | 54           | -17.84    | Average | Horizontal |
| 2483.50   | 46.13        | 33.06          | 35.18        | 3.60         | 47.61           | 74           | -26.39    | Peak    | Vertical   |
| 2483.53   | 36.54        | 33.08          | 35.18        | 3.60         | 38.04           | 54           | -15.96    | Average | Vertical   |
| 2489.01   | 44.68        | 33.08          | 35.18        | 3.62         | 46.20           | 74           | -27.80    | Peak    | Vertical   |
| 2489.04   | 34.79        | 33.08          | 35.18        | 3.62         | 36.31           | 54           | -17.69    | Average | Vertical   |

802.11n(HT40)

Tx-2422

| Freq. MHz | Reading dBuV | Ant. Fac. dB/m | Pre. Fac. dB | Cab. Loss dB | Measured dBuV/m | Limit dBuV/m | Margin dB | Remark  | Pol.       |
|-----------|--------------|----------------|--------------|--------------|-----------------|--------------|-----------|---------|------------|
| 2377.34   | 43.76        | 32.89          | 35.16        | 3.51         | 45.00           | 74           | -29.00    | Peak    | Horizontal |
| 2377.37   | 33.57        | 32.90          | 35.16        | 3.51         | 34.82           | 54           | -19.18    | Average | Horizontal |
| 2400.00   | 47.96        | 32.92          | 35.16        | 3.54         | 49.26           | 74           | -24.74    | Peak    | Horizontal |
| 2399.99   | 38.85        | 32.92          | 35.16        | 3.54         | 40.15           | 54           | -13.85    | Average | Horizontal |
| 2377.41   | 44.03        | 32.89          | 35.16        | 3.51         | 45.27           | 74           | -28.73    | Peak    | Vertical   |
| 2377.44   | 34.77        | 32.90          | 35.16        | 3.51         | 36.02           | 54           | -17.98    | Average | Vertical   |
| 2400.00   | 48.21        | 32.92          | 35.16        | 3.54         | 49.51           | 74           | -24.49    | Peak    | Vertical   |
| 2399.99   | 39.04        | 32.92          | 35.16        | 3.54         | 40.34           | 54           | -13.66    | Average | Vertical   |

Tx-2452

| Freq. MHz | Reading dBuV | Ant. Fac. dB/m | Pre. Fac. dB | Cab. Loss dB | Measured dBuV/m | Limit dBuV/m | Margin dB | Remark  | Pol.       |
|-----------|--------------|----------------|--------------|--------------|-----------------|--------------|-----------|---------|------------|
| 2483.50   | 46.75        | 33.06          | 35.18        | 3.60         | 48.23           | 74           | -25.77    | Peak    | Horizontal |
| 2483.54   | 36.37        | 33.08          | 35.18        | 3.60         | 37.87           | 54           | -16.13    | Average | Horizontal |
| 2491.26   | 44.33        | 33.08          | 35.18        | 3.62         | 45.85           | 74           | -28.15    | Peak    | Horizontal |
| 2491.29   | 33.17        | 33.08          | 35.18        | 3.62         | 34.69           | 54           | -19.31    | Average | Horizontal |
| 2483.50   | 47.16        | 33.06          | 35.18        | 3.60         | 48.64           | 74           | -25.36    | Peak    | Vertical   |
| 2483.53   | 36.69        | 33.08          | 35.18        | 3.60         | 38.19           | 54           | -15.81    | Average | Vertical   |
| 2491.33   | 44.45        | 33.08          | 35.18        | 3.62         | 45.97           | 74           | -28.03    | Peak    | Vertical   |
| 2491.37   | 33.32        | 33.08          | 35.18        | 3.62         | 34.84           | 54           | -19.16    | Average | Vertical   |

## 5.6. Conducted Spurious Emissions and Band Edges Test

### 5.6.1. Standard Applicable

According to §15.247 (d) & A8.5: In any 100 kHz bandwidth outside the frequency band in which the spread spectrum or digitally modulated intentional radiator is operating, the radio frequency power that is produced by the intentional radiator shall be at least 20 dB below that in the 100 kHz bandwidth within the band that contains the highest level of the desired power, based on either an RF conducted or a radiated measurement. Attenuation below the general limits specified in Section 15.209(a) is not required. In addition, radiated emissions which fall in the restricted bands, as defined in Section 15.205(a), must also comply with the radiated emission limits specified in Section 15.209(a) (see Section 15.205(c)).

### 5.6.2. Measuring Instruments and Setting

Please refer to section 6 of equipments list in this report. The following table is the setting of the spectrum analyzer.

| Spectrum Parameter                        | Setting       |
|---|---------------|
| Detector                                  | Peak          |
| Attenuation                               | Auto          |
| RB / VB (Emission in restricted band)     | 100KHz/300KHz |
| RB / VB (Emission in non-restricted band) | 100KHz/300KHz |

### 5.6.3. Test Procedures

The transmitter output is connected to a spectrum analyzer. The resolution bandwidth is set to 100 kHz. The video bandwidth is set to 100 kHz

The spectrum from 9kHz to 40GHz is investigated with the transmitter set to the lowest, middle, and highest channels.

Preliminary tests on individual chains, and on all chains with a combiner, were performed. The worst-case configuration was with a combiner, therefore final test were performed with all chains feeding a combiner.

### 5.6.4. Test Setup Layout

This test setup layout is the same as that shown in section 5.4.4.

### 5.6.5. EUT Operation during Test

The EUT was programmed to be in continuously transmitting mode.

5.6.6. Test Results of Conducted Spurious Emissions

802.11b

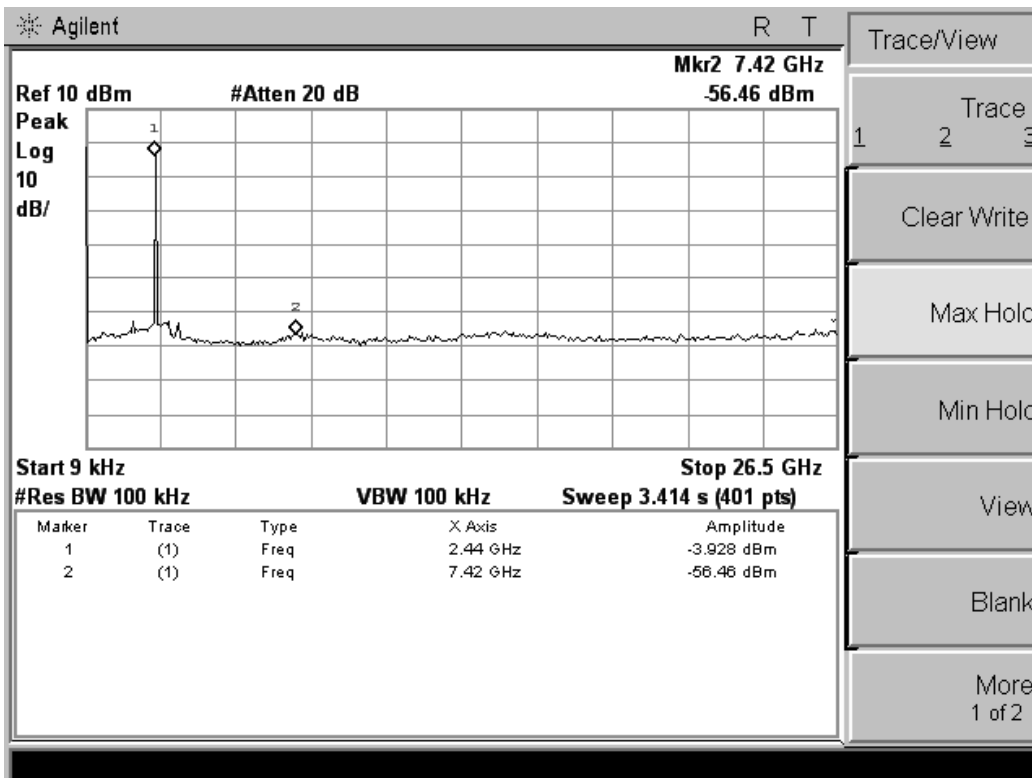
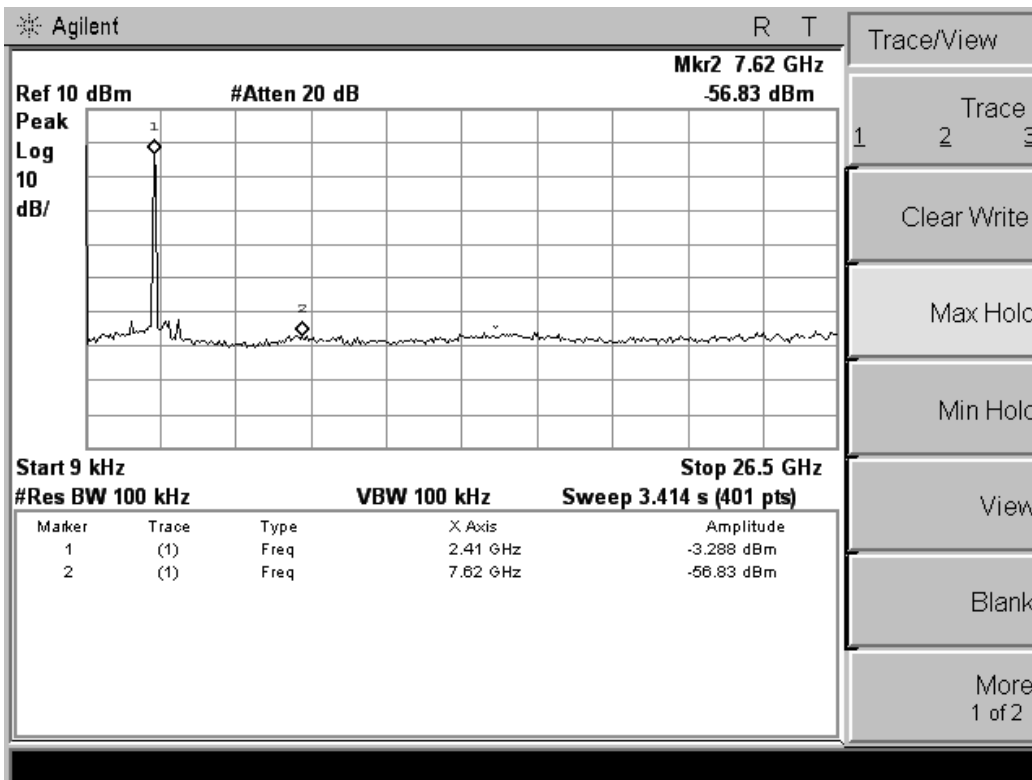

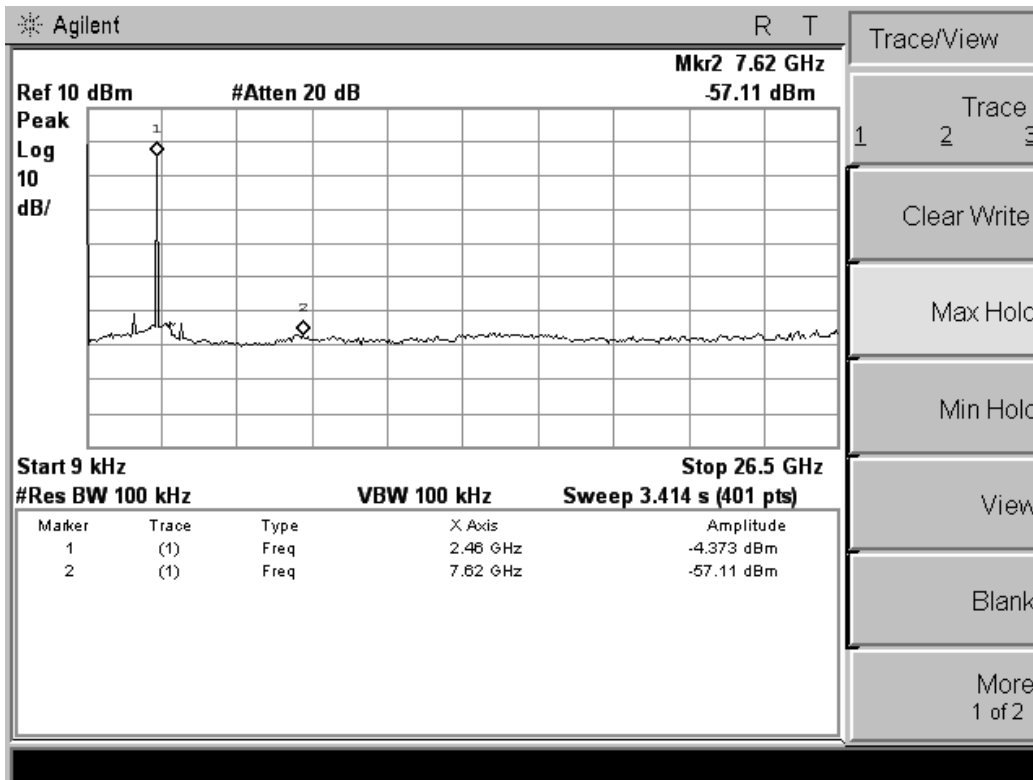

802.11g

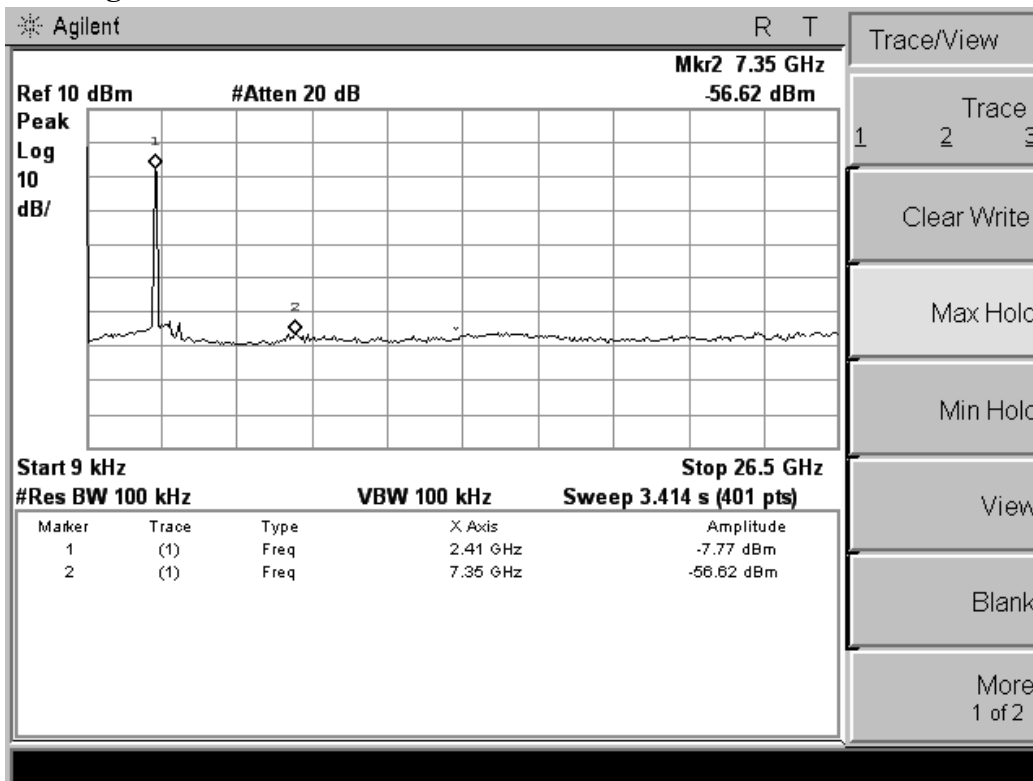

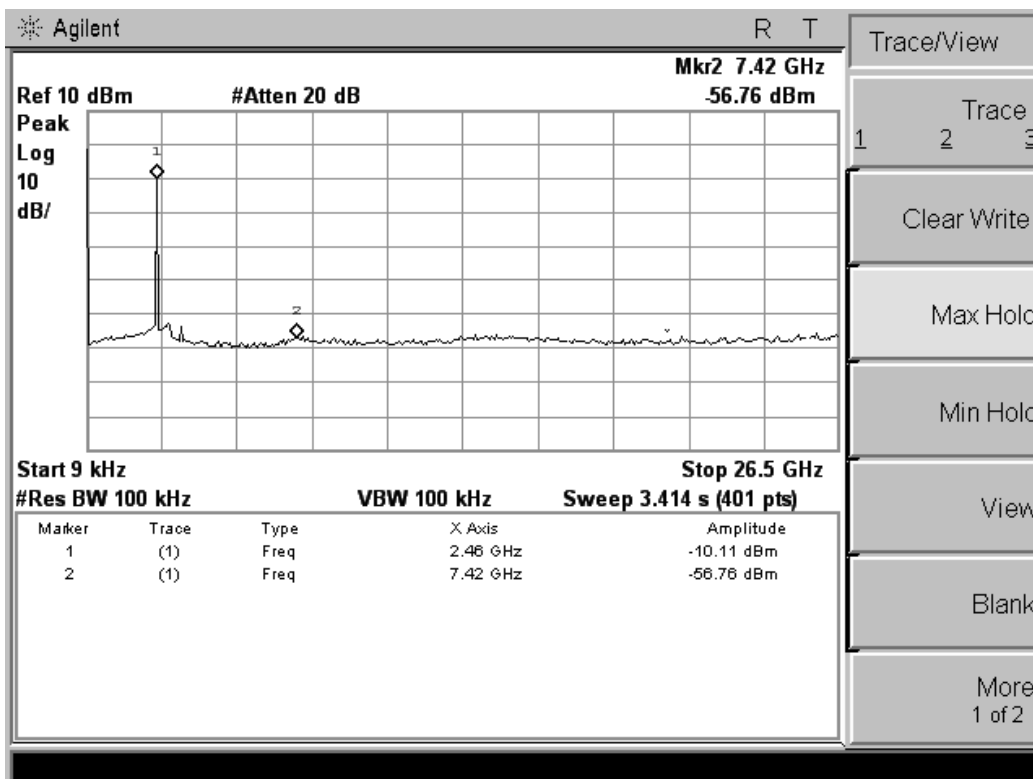
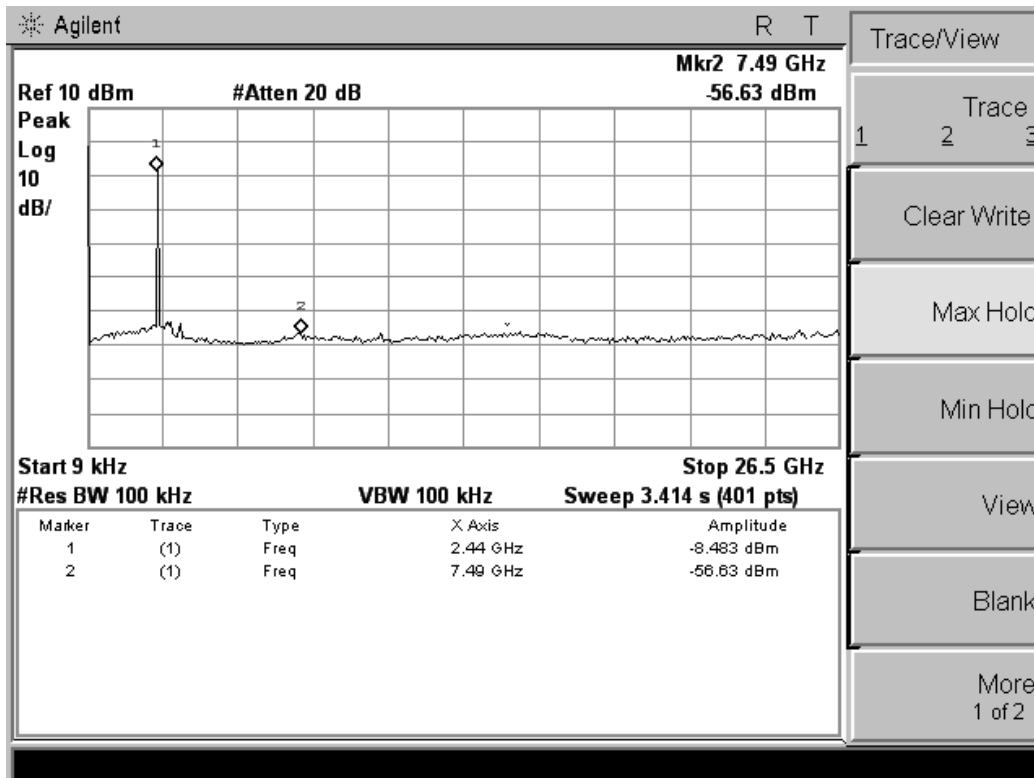

802.11n HT20

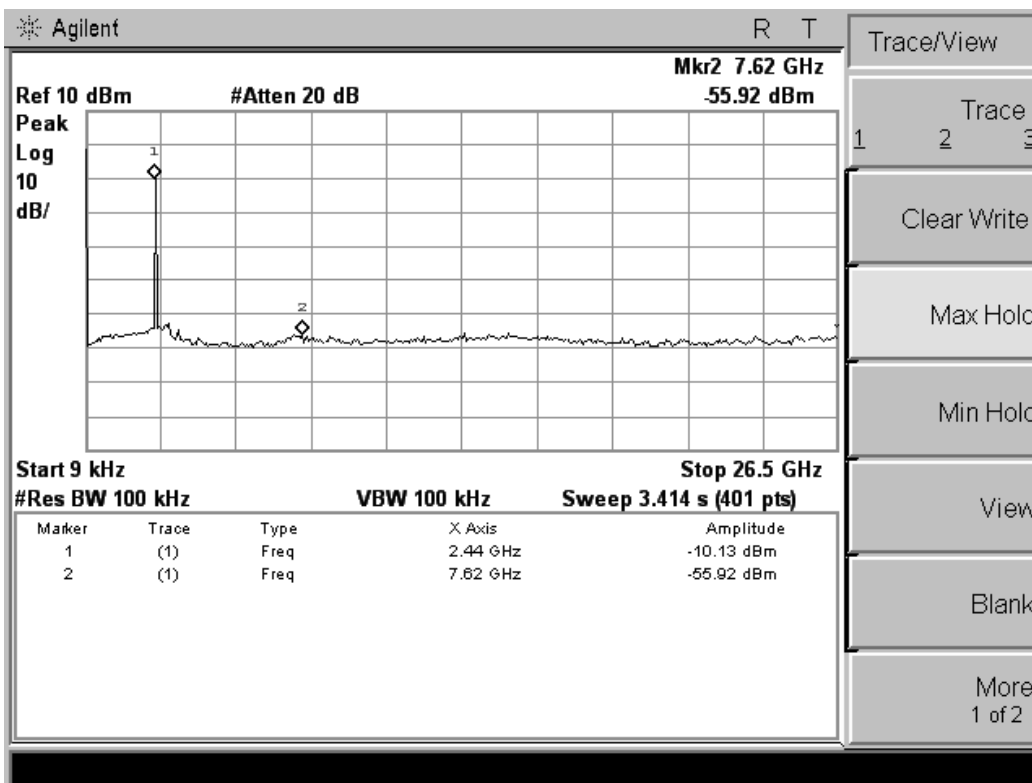
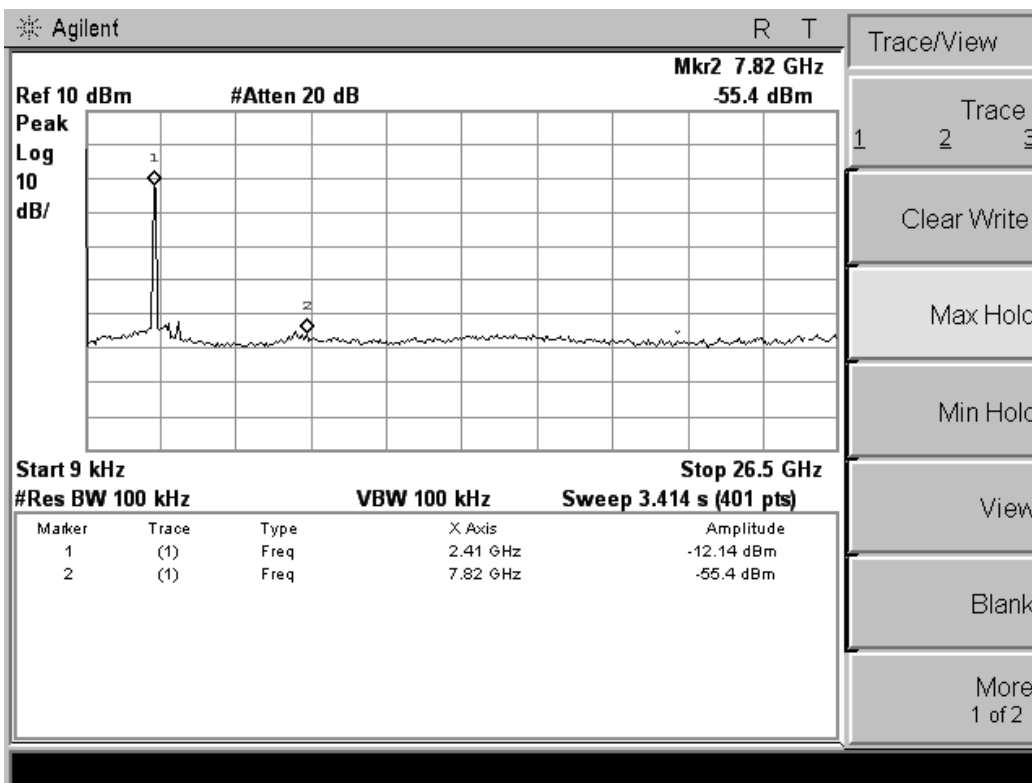

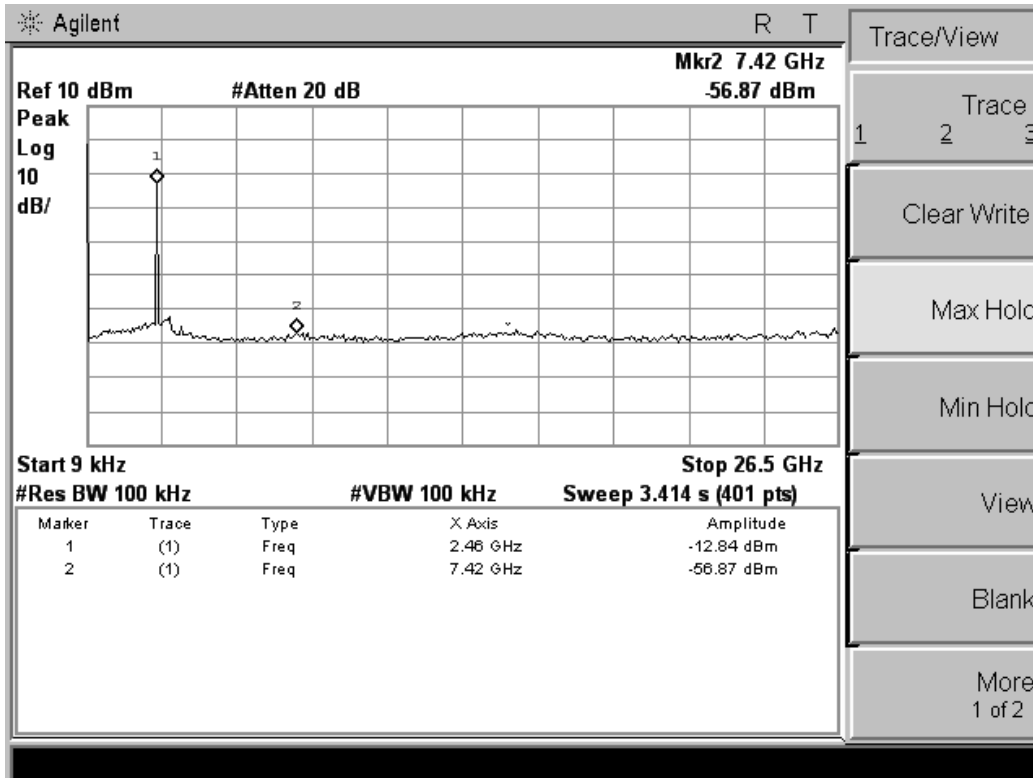

802.11n HT40

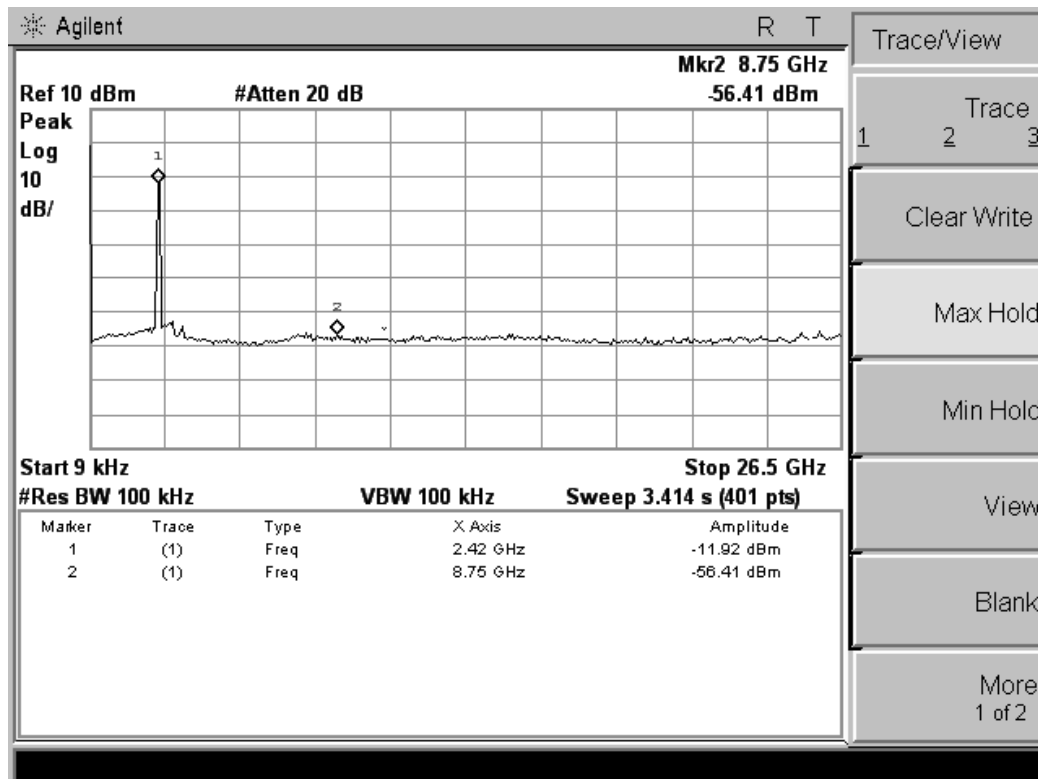



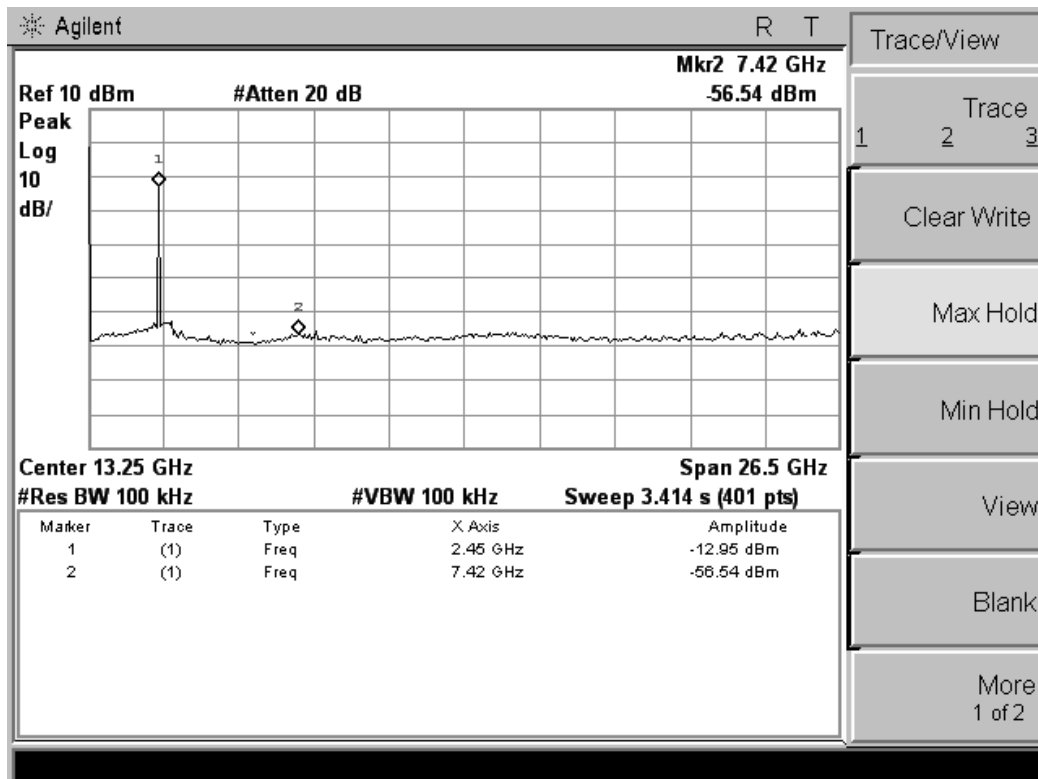
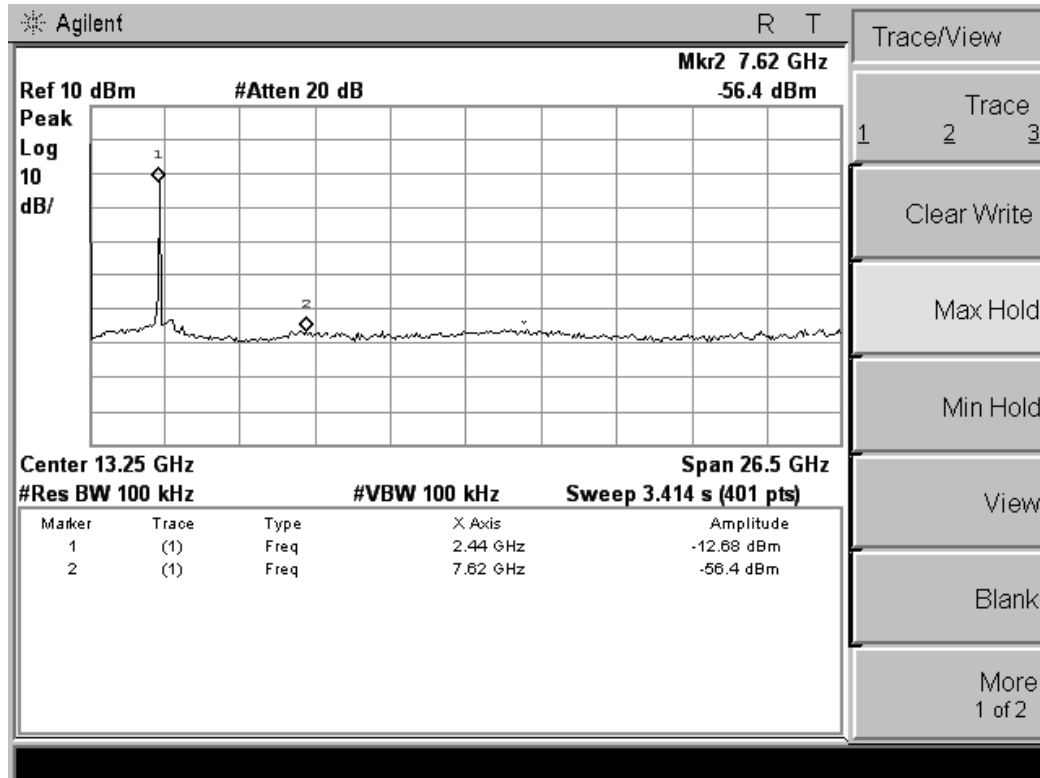

5.6.7. Test Results of Band Edges Test

802.11b

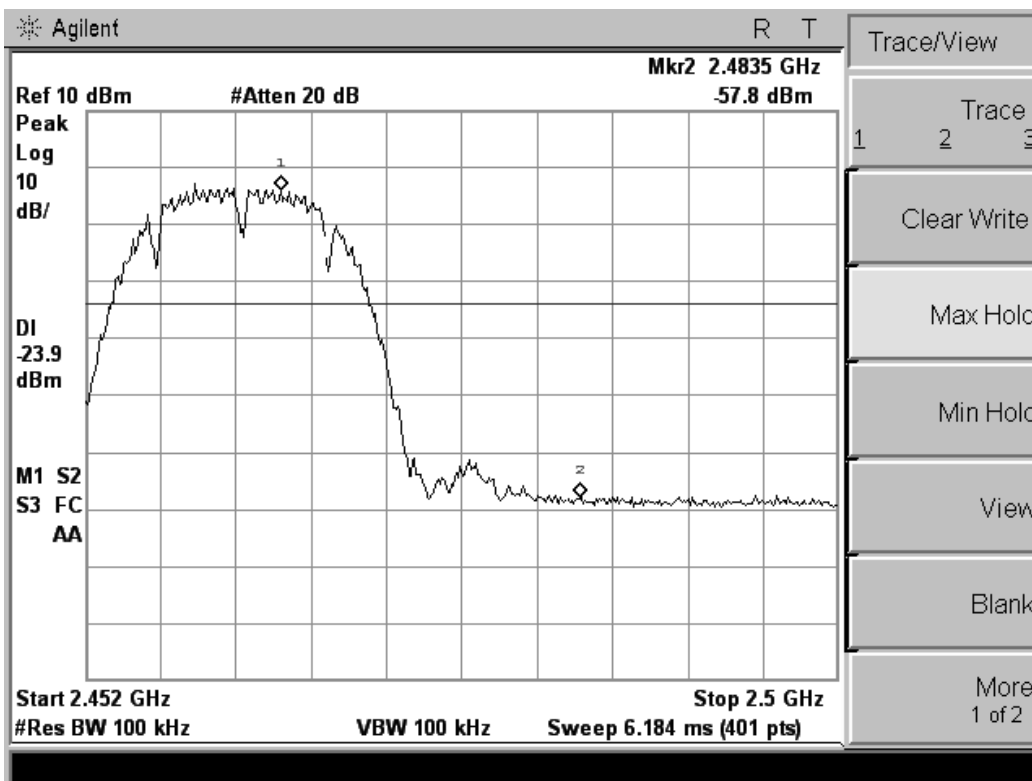
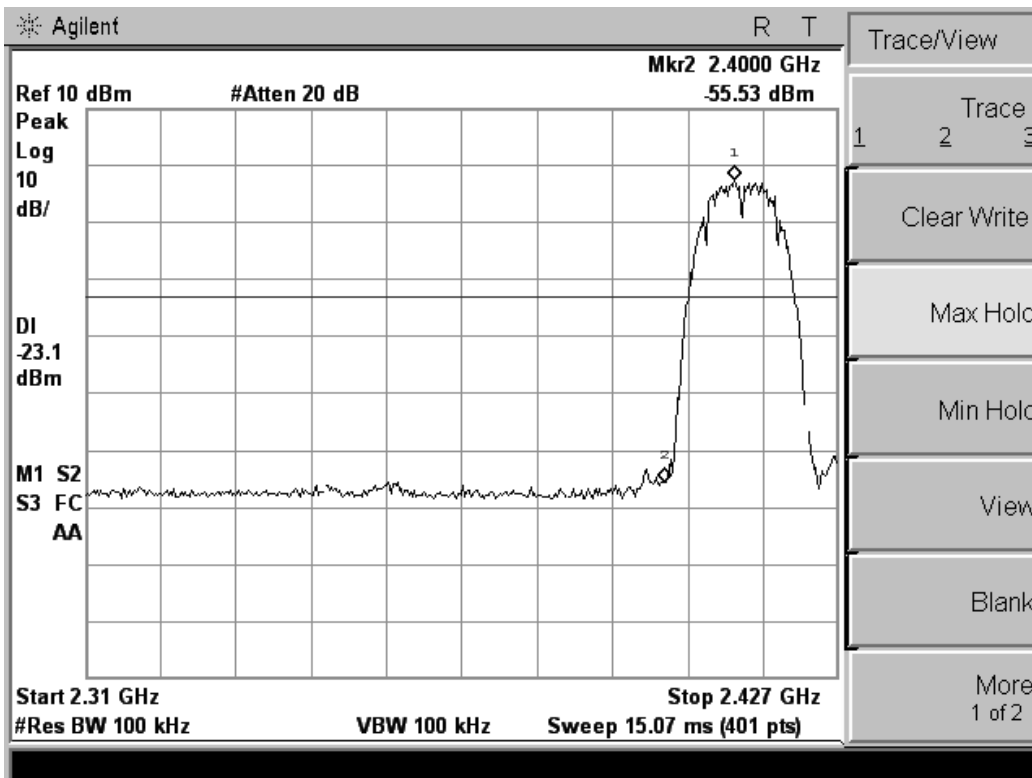

### 802.11g

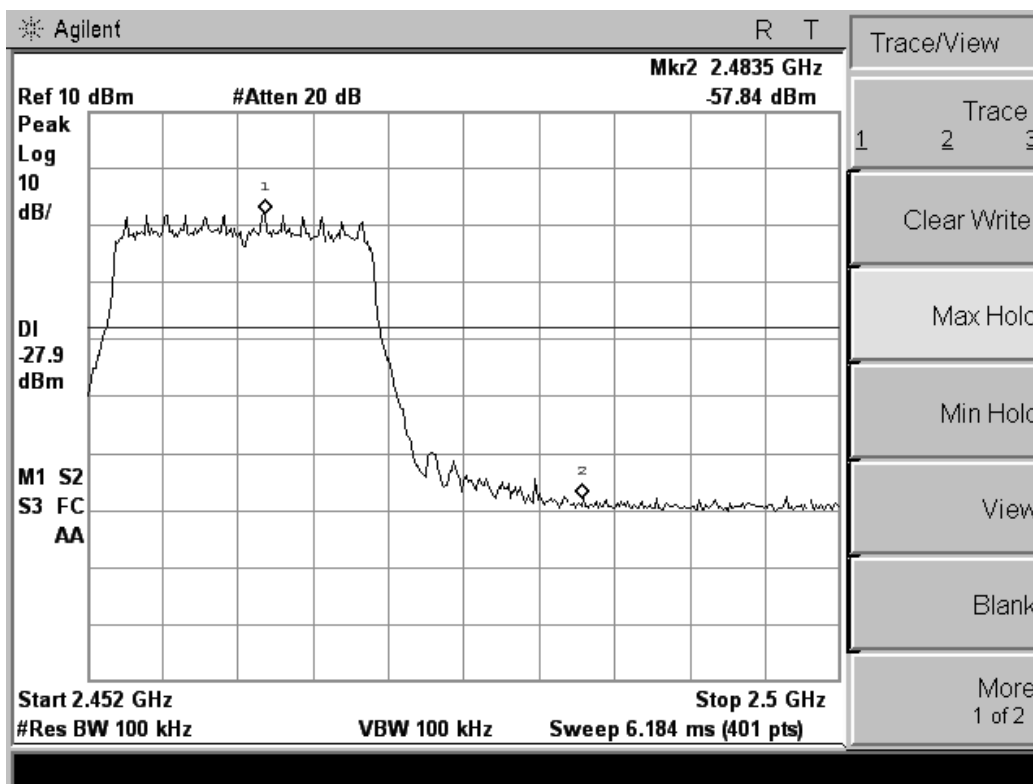
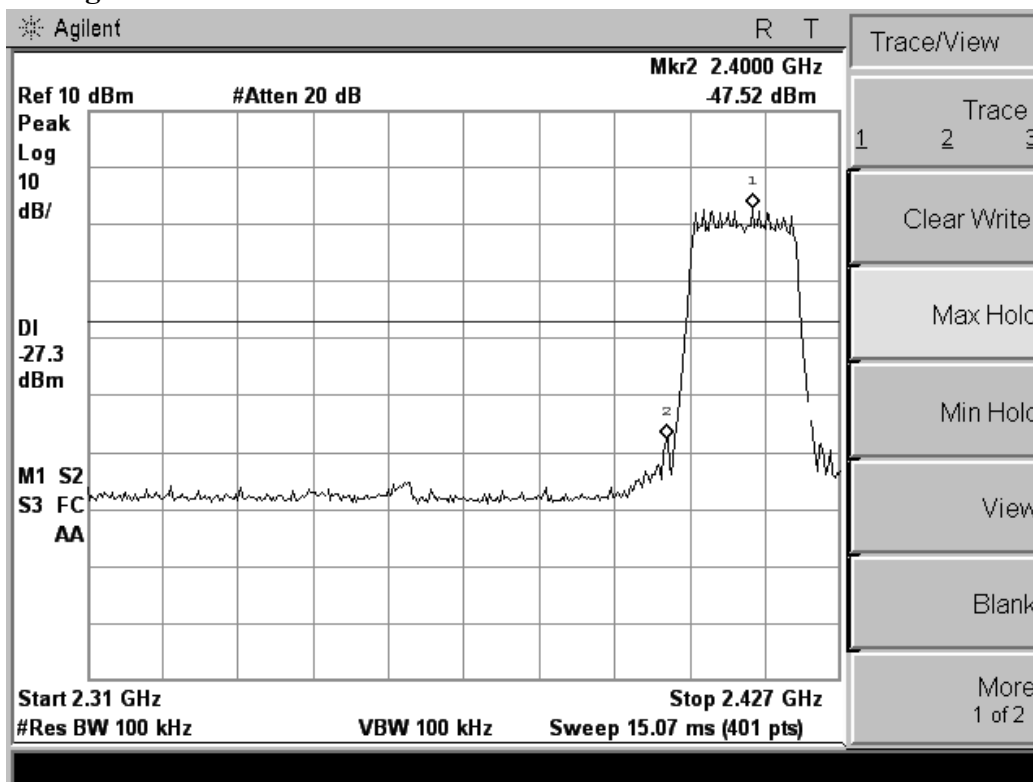

### 802.11n HT20

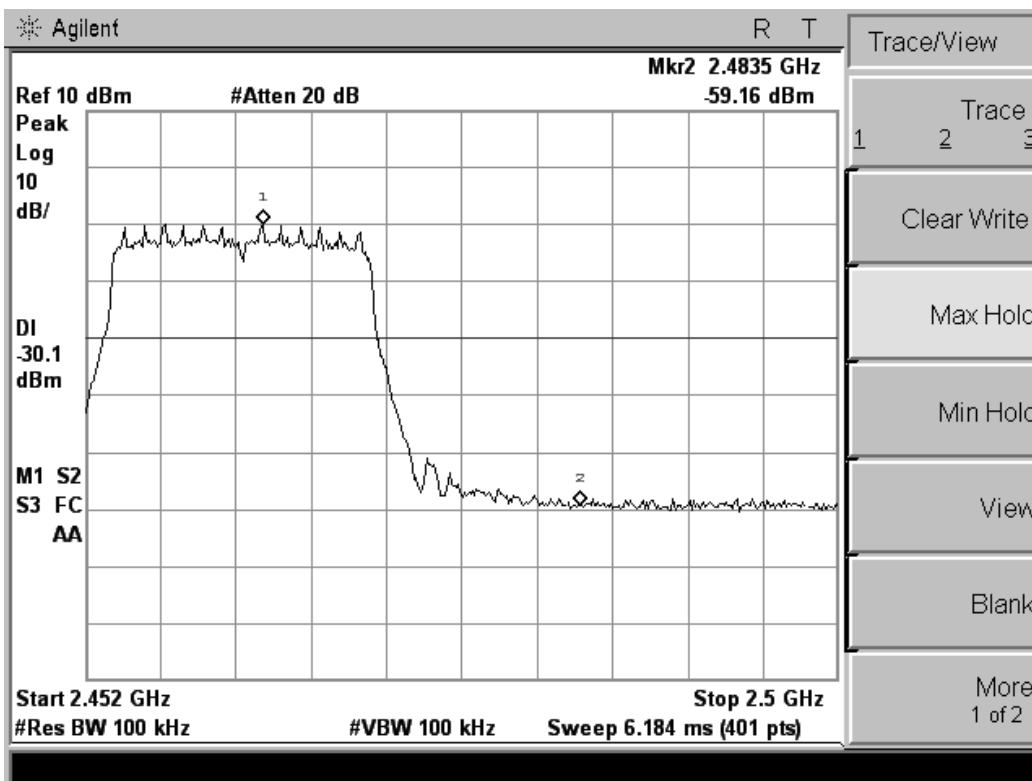
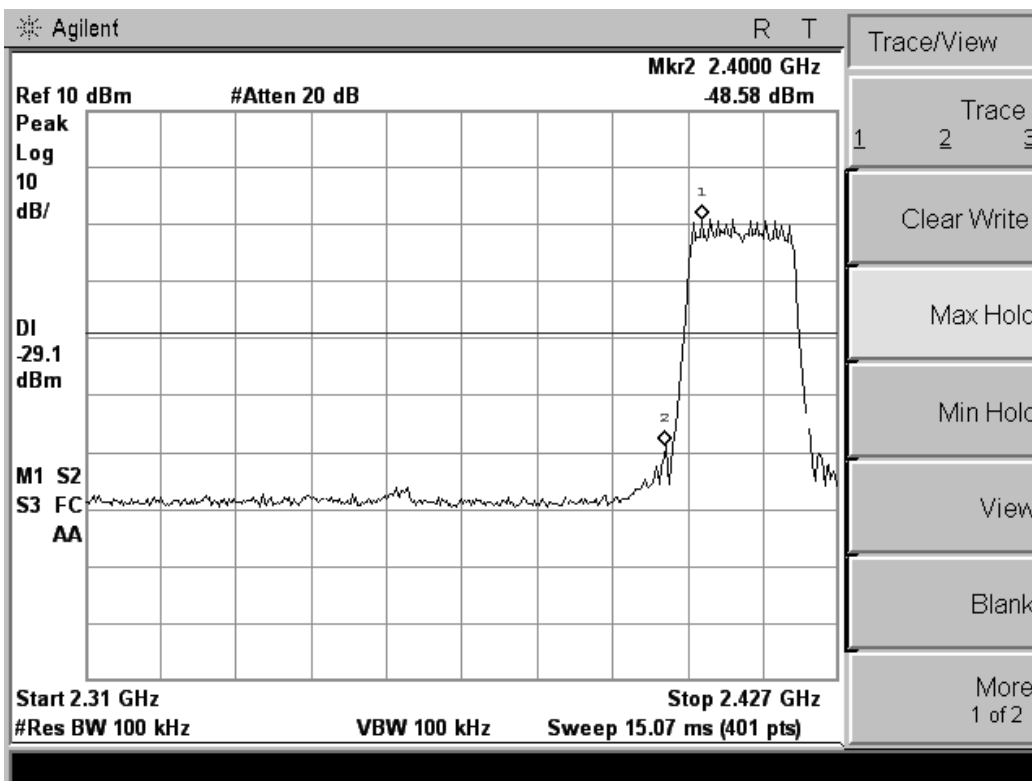

802.11n HT40

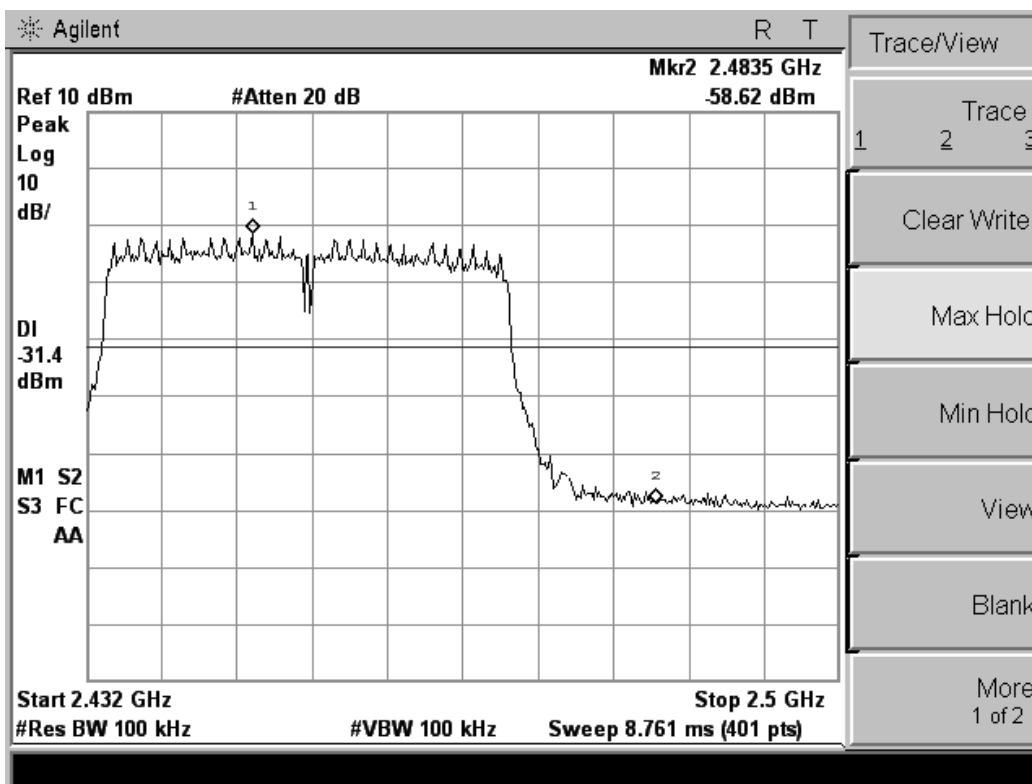
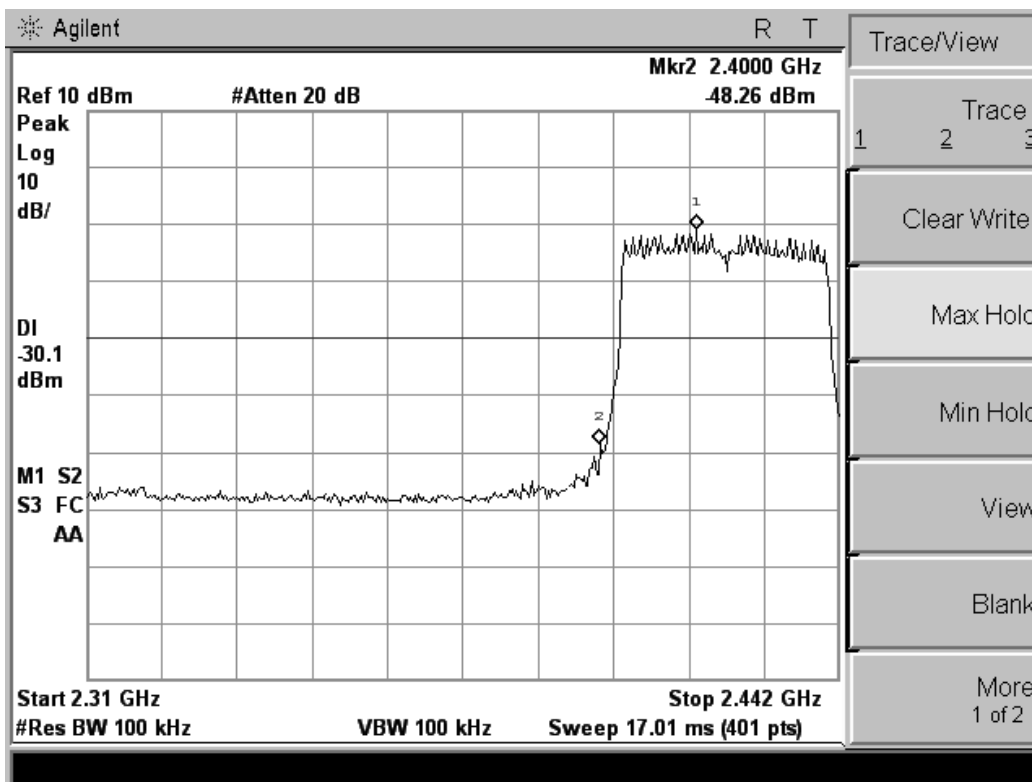

### 5.7. Power line conducted emissions

#### 5.7.1 Standard Applicable

According to §15.207 (a) or RSS-Gen: For an intentional radiator which is designed to be connected to the public utility (AC) power line, the radio frequency voltage that is conducted back onto the AC power line on any frequency or frequencies within the band 150 kHz to 30 MHz shall not exceed 250 microvolts (The limit decreases linearly with the logarithm of the frequency in the range 0.15 MHz to 0.50 MHz). The limits at specific frequency range is listed as follows:

| Frequency Range (MHz) | Limits (dBµV) |          |
|-----------------------|---------------|----------|
|                       | Quasi-peak    | Average  |
| 0.15 to 0.50          | 66 to 56      | 56 to 46 |
| 0.50 to 5             | 56            | 46       |
| 5 to 30               | 60            | 50       |

#### 5.7.2 Block Diagram of Test Setup

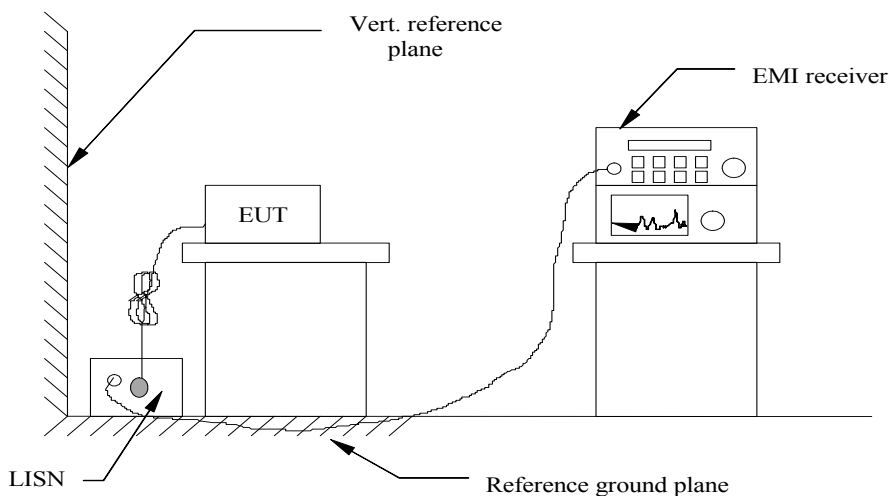

#### 5.7.3 Test Results

PASS.

The test data please refer to following page.

Test result for 802.11b (Low Channel)

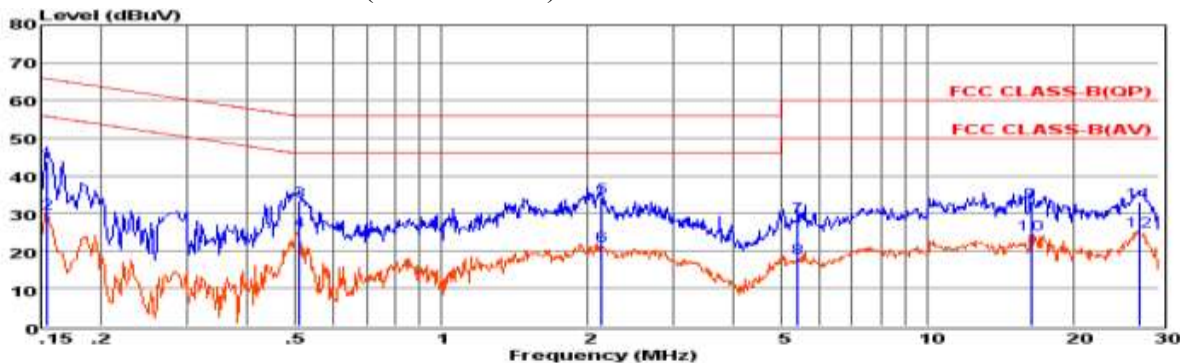

Env. Ins: 24\*/56%  
 EUT: Tablet PC  
 M/N: HS-10DTB8  
 Power Rating: AC 120V/60Hz  
 Test Mode: TX-2412(802.11b)  
 Operator: Tree  
 Memo:  
 Pol: NEUTRAL

|    | Freq  | Reading | LisnFac | CabLos | Measured | Limit | Over   | Remark  |
|----|-------|---------|---------|--------|----------|-------|--------|---------|
|    | MHz   | dBuV    | dB      | dB     | dBuV     | dBuV  | dB     |         |
| 1  | 0.15  | 33.95   | 9.69    | 0.02   | 43.66    | 65.74 | -22.08 | QP      |
| 2  | 0.15  | 20.43   | 9.69    | 0.02   | 30.14    | 55.74 | -25.60 | Average |
| 3  | 0.51  | 23.69   | 9.62    | 0.04   | 33.35    | 56.00 | -22.65 | QP      |
| 4  | 0.51  | 15.49   | 9.62    | 0.04   | 25.15    | 46.00 | -20.85 | Average |
| 5  | 2.13  | 24.47   | 9.63    | 0.05   | 34.15    | 56.00 | -21.85 | QP      |
| 6  | 2.13  | 11.67   | 9.63    | 0.05   | 21.35    | 46.00 | -24.65 | Average |
| 7  | 5.42  | 19.29   | 9.67    | 0.06   | 29.02    | 60.00 | -30.98 | QP      |
| 8  | 5.42  | 8.51    | 9.67    | 0.06   | 18.24    | 50.00 | -31.76 | Average |
| 9  | 16.31 | 23.06   | 9.75    | 0.11   | 32.92    | 60.00 | -27.08 | QP      |
| 10 | 16.31 | 14.58   | 9.75    | 0.11   | 24.44    | 50.00 | -25.56 | Average |
| 11 | 27.27 | 23.00   | 9.83    | 0.13   | 32.96    | 60.00 | -27.04 | QP      |
| 12 | 27.27 | 15.35   | 9.83    | 0.13   | 25.31    | 50.00 | -24.69 | Average |

Remarks: 1. Measured = Reading + Lisn Factor +Cable Loss.  
 2. The emission levels that are 20dB below the official limit are not reported.

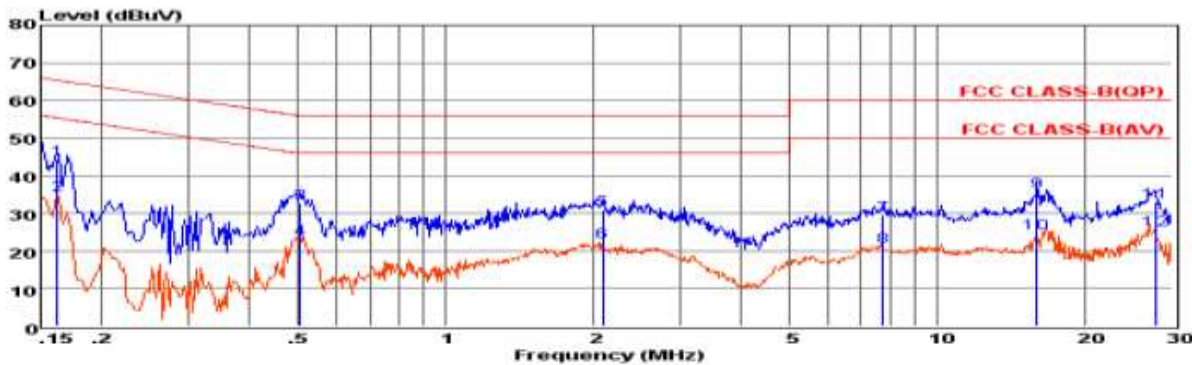

Env. Ins: 24\*/56%  
 EUT: Tablet PC  
 M/N: HS-10DTB8  
 Power Rating: AC 120V/60Hz  
 Test Mode: TX-2412(802.11b)  
 Operator: Tree  
 Memo:  
 Pol: LINE

|    | Freq  | Reading | LisnFac | CabLos | Measured | Limit | Over   | Remark  |
|----|-------|---------|---------|--------|----------|-------|--------|---------|
|    | MHz   | dBuV    | dB      | dB     | dBuV     | dBuV  | dB     |         |
| 1  | 0.16  | 34.58   | 9.59    | 0.02   | 44.19    | 65.34 | -21.15 | QP      |
| 2  | 0.16  | 25.27   | 9.59    | 0.02   | 34.88    | 55.34 | -20.46 | Average |
| 3  | 0.50  | 23.00   | 9.62    | 0.04   | 32.66    | 56.00 | -23.34 | QP      |
| 4  | 0.50  | 13.54   | 9.62    | 0.04   | 23.20    | 46.00 | -22.80 | Average |
| 5  | 2.09  | 21.27   | 9.64    | 0.05   | 30.96    | 56.00 | -25.04 | QP      |
| 6  | 2.09  | 12.72   | 9.64    | 0.05   | 22.41    | 46.00 | -23.59 | Average |
| 7  | 7.77  | 19.55   | 9.68    | 0.07   | 29.30    | 60.00 | -30.70 | QP      |
| 8  | 7.77  | 11.48   | 9.68    | 0.07   | 21.23    | 50.00 | -28.77 | Average |
| 9  | 15.97 | 25.89   | 9.72    | 0.11   | 35.72    | 60.00 | -24.28 | QP      |
| 10 | 15.97 | 14.81   | 9.72    | 0.11   | 24.64    | 50.00 | -25.36 | Average |
| 11 | 27.71 | 23.12   | 9.71    | 0.14   | 32.97    | 60.00 | -27.03 | QP      |
| 12 | 27.71 | 15.87   | 9.71    | 0.14   | 25.72    | 50.00 | -24.28 | Average |

Remarks: 1. Measured = Reading + Lisn Factor +Cable Loss.  
 2. The emission levels that are 20dB below the official limit are not reported.

\*\*\*Note: Pre-scan all mode and recorded the worst case results in this report (802.11b (Low Channel)).

## 5.8. Antenna Requirements

### 5.8.1. Standard Applicable

According to § 15.203 & RSS-Gen, an intentional radiator shall be designed to ensure that no antenna other than that furnished by the responsible party shall be used with the device.

### 5.8.2. Antenna Connector Construction

The integral antenna (which max. gain is 2.0dBi) is permanently attached and no consideration of replacement. Please see EUT photo for details.

### 5.8.3. Results: Compliance.



## 6. LIST OF MEASURING EQUIPMENTS

| Instrument                    | Manufacturer   | Model No.                        | Serial No.  | Characteristics | Cal Date     | Due Date     |
|-------------------------------|----------------|----------------------------------|-------------|-----------------|--------------|--------------|
| EMC Receiver                  | R&S            | ESCS 30                          | 100174      | 9kHz – 2.75GHz  | June 18,2013 | June 17,2014 |
| Signal analyzer               | Agilent        | E4448A(External mixers to 40GHz) | US44300469  | 9kHz-40GHz      | July 16,2013 | July 15,2014 |
| LISN                          | MESS Tec       | NNB-2/16Z                        | 99079       | 9KHz-30MHz      | June 18,2013 | June 17,2014 |
| LISN (Support Unit)           | EMCO           | 3819/2NM                         | 9703-1839   | 9KHz-30MHz      | June 18,2013 | June 17,2014 |
| RF Cable-CON                  | UTIFLEX        | 3102-26886-4                     | CB049       | 9KHz-30MHz      | June 18,2013 | June 17,2014 |
| ISN                           | SCHAFFNER      | ISN ST08                         | 21653       | 9KHz-30MHz      | June 18,2013 | June 17,2014 |
| 3m Semi Anechoic Chamber      | SIDT FRANKONIA | SAC-3M                           | 03CH03-HY   | 30M-1GHz<br>3m  | June 18,2013 | June 17,2014 |
| Amplifier                     | SCHAFFNER      | COA9231A                         | 18667       | 9kHz-2GHz       | June 18,2013 | June 17,2014 |
| Amplifier                     | Agilent        | 8449B                            | 3008A02120  | 1GHz-26.5GHz    | July 16,2013 | July 15,2014 |
| Amplifier                     | MITEQ          | AMF-6F-260400                    | 9121372     | 26.5GHz-40GHz   | July 16,2013 | July 15,2014 |
| Spectrum Analyzer             | Agilent        | E4407B                           | MY41440292  | 9k-26.5GHz      | July 16,2013 | July 15,2014 |
| Loop Antenna                  | R&S            | HFH2-Z2                          | 860004/001  | 9k-30MHz        | June 18,2013 | June 17,2014 |
| By-log Antenna                | SCHWARZBECK    | VULB9163                         | 9163-470    | 30MHz-1GHz      | June 10,2013 | June 09,2014 |
| Horn Antenna                  | EMCO           | 3115                             | 6741        | 1GHz-18GHz      | June 10,2013 | June 09,2014 |
| Horn Antenna                  | SCHWARZBECK    | BBHA9170                         | BBHA9170154 | 15GHz-40GHz     | June 10,2013 | June 09,2014 |
| RF Cable-R03m                 | Jye Bao        | RG142                            | CB021       | 30MHz-1GHz      | June 18,2013 | June 17,2014 |
| RF Cable-HIGH                 | SUHNER         | SUCOFLEX 106                     | 03CH03-HY   | 1GHz-40GHz      | June 18,2013 | June 17,2014 |
| Spectrum Meter                | R&S            | FSP 30                           | 100023      | 9kHz-30GHz      | July 16,2013 | July 15,2014 |
| Power Meter                   | R&S            | NRVS                             | 100444      | DC-40GHz        | June 18,2013 | June 17,2014 |
| Power Sensor                  | R&S            | NRV-Z51                          | 100458      | DC-30GHz        | June 18,2013 | June 17,2014 |
| Power Sensor                  | R&S            | NRV-Z32                          | 10057       | 30MHz-6GHz      | June 18,2013 | June 17,2014 |
| AC Power Source               | HPC            | HPA-500E                         | HPA-9100024 | AC 0~300V       | June 18,2013 | June 17,2014 |
| DC power Source               | GW             | GPC-6030D                        | C671845     | DC 1V-60V       | June 18,2013 | June 17,2014 |
| Temp. and Humidity            | Giant Force    | GTH-225-20-S                     | MAB0103-00  | N/A             | June 18,2013 | June 17,2014 |
| RF CABLE-1m                   | JYE Bao        | RG142                            | CB034-1m    | 20MHz-7GHz      | June 18,2013 | June 17,2014 |
| RF CABLE-2m                   | JYE Bao        | RG142                            | CB)35-2m    | 20MHz-1GHz      | June 18,2013 | June 17,2014 |
| Vector signal Generator       | R&S            | SMU200A                          | 102098      | 100kHz~6GHz     | June 18,2013 | June 17,2014 |
| Signal Generator              | R&S            | SMR40                            | 10016       | 10MHz~40GHz     | July 16,2013 | July 15,2014 |
| Universal Radio Communication | R&S            | CMU200                           | 112012      | N/A             | July 18,2013 | July 17,2014 |

Note: All equipment through GRGT EST calibration

### 7. MANUFACTURER/ APPROVAL HOLDER DECLARATION

The following series model(s):

|    |    |    |    |
|----|----|----|----|
| -- | -- | -- | -- |
|----|----|----|----|

Belong to the tested device:

Product description : Tablet PC

Model name : HS-10DTB8

Remark: No additional models were tested.

-----THE END OF REPORT-----