

FCC Test Report

Product Name	RRNM-IDG
Model No.	HUF7059
FCC ID.	YGOHUF7059

Applicant	Huf Hülbeck & Fürst GmbH & Co. KG
Address	Steeger Str. 17, 42551 Velbert, Germany

Date of Receipt	Dec. 14, 2016
Issued Date	Jan. 09, 2017
Report No.	16C0304R-RFUSP14V00
Report Version	V1.0



The test results relate only to the samples tested.

The test results shown in the test report are traceable to the national/international standard through the calibration of the equipment and evaluated measurement uncertainty herein.

This report must not be used to claim product endorsement by TAF or any agency of the government.

The test report shall not be reproduced without the written approval of DEKRA Testing and Certification Co., Ltd.

Test Report

Issued Date : Jan. 09, 2017

Report No. : 16C0304R-RFUSP14V00



Product Name	RRNM-IDG
Applicant	Huf Hülsbeck & Fürst GmbH & Co. KG
Address	Steger Str. 17, 42551 Velbert, Germany
Manufacturer	Huf Hülsbeck & Fürst GmbH & Co. KG
Model No.	HUF7059
FCC ID.	YGOHUF7059
EUT Rated Voltage	DC 3V(Power by Battery)
EUT Test Voltage	DC 3V(Power by Battery)
Trade Name	HUF
Applicable Standard	FCC CFR Title 47 Part 15 Subpart C: 2015 ANSI C63.4: 2014, ANSI C63.10: 2013
Test Result	Complied

Documented By :



(Senior Adm. Specialist / Genie Chang)

Tested By :



(Engineer / Tim Chen)

Approved By :



(Director / Vincent Lin)

TABLE OF CONTENTS

Description	Page
1. General Information	4
1.1. EUT Description.....	4
1.2. Operation Description	5
1.3. Tested System Details.....	6
1.4. Configuration of tested System	6
1.5. EUT Exercise Software	6
1.6. Test Facility	7
1.7. List of Test Equipment	8
2. Conducted Emission.....	9
2.1. Test Setup	9
2.2. Limits	10
2.3. Test Procedure	10
2.4. Test Specification	10
2.5. Uncertainty	10
2.6. Test Result	11
3. Radiated Emission.....	12
3.1. Test Setup	12
3.2. Limits	14
3.3. Test Procedure	15
3.4. Test Specification	15
3.5. Uncertainty	15
3.6. Test Result	16
4. Transmit time.....	28
4.1. Test Setup	28
4.2. Limits	28
4.3. Test Specification	28
4.4. Uncertainty	28
4.5. Test Result	29
5. Occupied Bandwidth.....	31
5.1. Test Setup	31
5.2. Limits	31
5.3. Test Specification	31
5.4. Uncertainty	31
5.5. Test Result	32

Attachment 1: EUT Test Photographs

Attachment 2: EUT Detailed Photographs

1. General Information

1.1. EUT Description

Product Name	RRNM-IDG
Trade Name	HUF
Model No.	HUF7059
FCC ID	YGOHUF7059
Frequency Range	433.2MHz, 434.64MHz
Number of Channels	2
Type of Modulation	FSK
Antenna Type	PCB loop antenna

Frequency of Each Channel:

Channel	Frequency	Channel	Frequency
Channel 1:	433.2 MHz	Channel 2:	434.64 MHz

Note:

1. The EUT is a RRNM-IDG with a built-in 433.2MHz, 434.64MHz transceiver.
2. The antenna of EUT is conform to FCC 15.203
3. These tests are conducted on a sample for the purpose of demonstrating compliance with Part 15 Subpart C Paragraph 15.231.
4. The radiation measurements are performed in X, Y, Z axis positioning. Only the worst case is shown in the report.

Test Mode	Mode 1: Transmit
-----------	------------------

1.3. Tested System Details

The types for all equipments, plus descriptions of all cables used in the tested system (including inserted cards) are:

Product	Manufacturer	Model No.	Serial No.	FCC ID	Power Cord
N/A					

Signal Cable Type	Signal cable Description
N/A	

1.4. Configuration of tested System

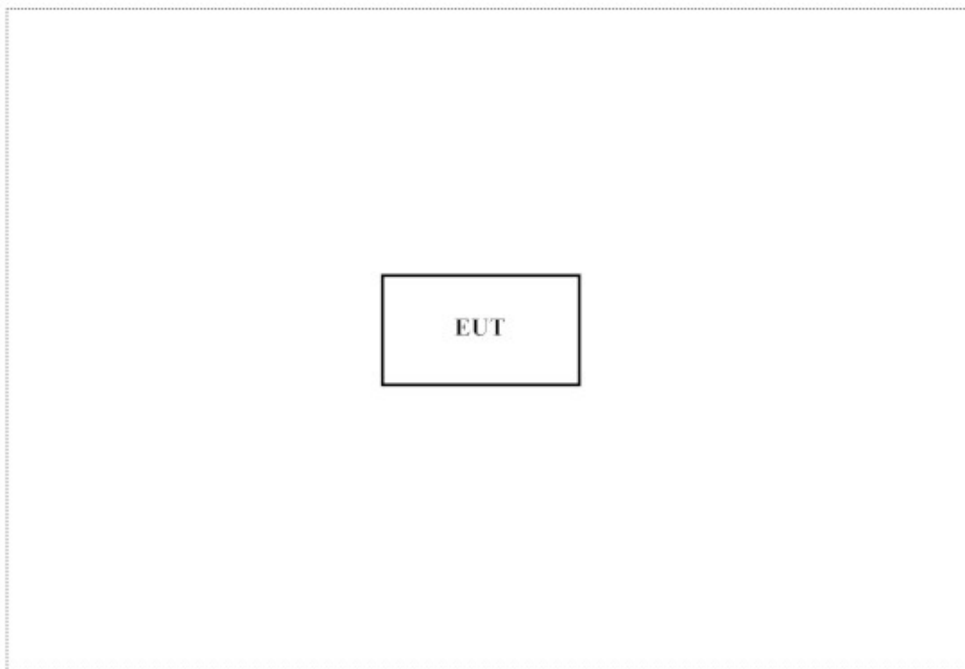

1.5. EUT Exercise Software

1	Setup the EUT as shown in section 1.4.
2	Push the button, start transmit continually.
3	Verify that the EUT works properly.

1.6. Test Facility

Ambient conditions in the laboratory:

Items	Required (IEC 68-1)	Actual
Temperature (°C)	15-35	20-35
Humidity (%RH)	25-75	30-65
Barometric pressure (mbar)	860-1060	950-1000

The related certificate for our laboratories about the test site and management system can be downloaded from DEKRA Corporation's Web Site: <http://www.dekra.com.tw/english/about/certificates.aspx?bval=5>

The address and introduction of DEKRA Corporation's laboratories can be founded in our Web site: http://www.dekra.com.tw/index_en.aspx

Site Description: File on
Federal Communications Commission
FCC Engineering Laboratory
7435 Oakland Mills Road
Columbia, MD 21046
Registration Number: 92195

Site Name: DEKRA Testing and Certification Co., Ltd.
Site Address: No.5-22, Ruishukeng Linkou Dist., New Taipei City
24451, Taiwan, R.O.C.
TEL: 886-2-8601-3788 / FAX : 886-2-8601-3789
E-Mail : info.tw@dekra.com

FCC Accreditation Number: TW1014

1.7. List of Test Equipment

For Conducted measurements /CB3/SR8

	Equipment	Manufacturer	Model No.	Serial No.	Cali. Data	Due. Data
X	Spectrum Analyzer	R&S	FSV30	103466	2016/12/14	2017/12/13
	Power Meter	Anritsu	ML2495A	6K00003357	2016/6/23	2017/6/22
	Pulse power sensor	Anritsu	MA2411B	0846193	2016/6/23	2017/6/22
	EMI Test Receiver	R&S	ESCS 30	100369	2016/10/13	2017/10/12
	LISN	R&S	ESH3-Z5	836679/017	2016/1/7	2017/1/6
	LISN	R&S	ENV216	100097	2016/1/7	2017/1/6
	Coaxial Cable	QTK(Arnist)	RG 400	LC018-RG	2016/6/25	2017/6/24

For Radiated measurements /Site3/CB8

	Equipment	Manufacturer	Model No.	Serial No.	Cali. Data	Due. Data
X	Spectrum Analyzer	R&S	FSP40	100170	2016/1/5	2017/1/4
X	Loop Antenna	Teseq	HLA6121	37133	2016/3/18	2017/3/17
X	Bi-Log Antenna	Schaffner Chase	CBL6112B	2707	2016/6/11	2017/6/10
X	Horn Antenna	ETS-Lindgren	3117	00135205	2016/4/6	2017/4/5
	Horn Antenna	Schwarzbeck	BBHA9170	9170430	2016/1/11	2017/1/10
X	Pre-Amplifier	QTK	AP/0100A	CHM/0901069	2016/6/23	2017/6/22
X	Pre-Amplifier	EMCI	EMC012630SE	980210	2016/1/26	2017/1/24
	Pre-Amplifier	NARDA WE	DBL-1840N506	013	2016/9/30	2017/9/29
	Filter	MicroTRON	BRM50701	019	2016/11/2	2017/11/1
X	EMI Test Receiver	R&S	ESR26	101385	2016/9/29	2017/9/28
X	Coaxial Cable	QTK(Arnist)	SUCOFLEX 106	L1606-015C	2016/6/23	2017/6/22
X	EMI Test Receiver	R&S	ESCS 30	838251/001	2016/7/21	2017/7/20
X	Coaxial Cable	QTK(Arnist)	RG 214	LC003-RG	2016/6/16	2017/6/15
X	Coaxial signal switch	Anritsu	MP59B	6201415889	2016/6/16	2017/6/15

Note:

1. All equipments are calibrated every one year.
2. The test instruments marked with "X" are used to measure the final test results.
3. Test Software version : QuieTek EMI 2.0 V2.1.113.

2. Conducted Emission

2.1. Test Setup

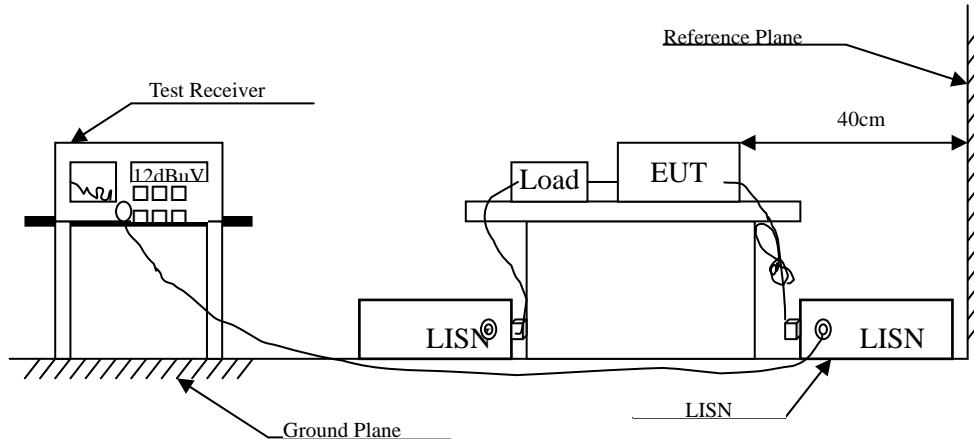

2.2. Limits

FCC Part 15 Subpart C Paragraph 15.207 Limits (dBuV)		
Frequency MHz	QP	AV
0.15 - 0.50	66-56	56-46
0.50-5.0	56	46
5.0 - 30	60	50

Remarks : In the above table, the tighter limit applies at the band edges.

2.3. Test Procedure

The EUT and simulators are connected to the main power through a line impedance stabilization network (L.I.S.N.). This provides a 50 ohm /50uH coupling impedance for the measuring equipment. The peripheral devices are also connected to the main power through a LISN that provides a 50ohm/50uH coupling impedance with 50ohm termination. (Please refers to the block diagram of the test setup and photographs.)

Both sides of A.C. line are checked for maximum conducted interference. In order to find the maximum emission, the relative positions of equipment and all of the interface cables must be changed according to ANSI C63.10: 2009 on conducted measurement.

Conducted emissions were investigated over the frequency range from 0.15MHz to 30MHz using a receiver bandwidth of 9kHz.

2.4. Test Specification

According to FCC Part 15 Subpart C Paragraph 15.231

2.5. Uncertainty

± 2.26 dB

2.6. Test Result

Owing to the DC operation of EUT, this test item is not performed.

3. Radiated Emission

3.1. Test Setup

Radiated Emission Under 30MHz

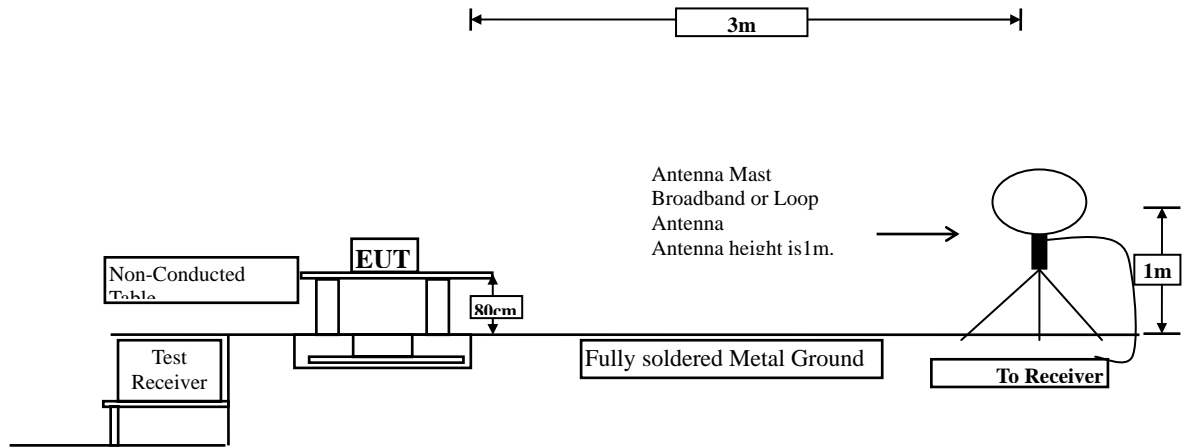

Radiated Emission Below 1GHz

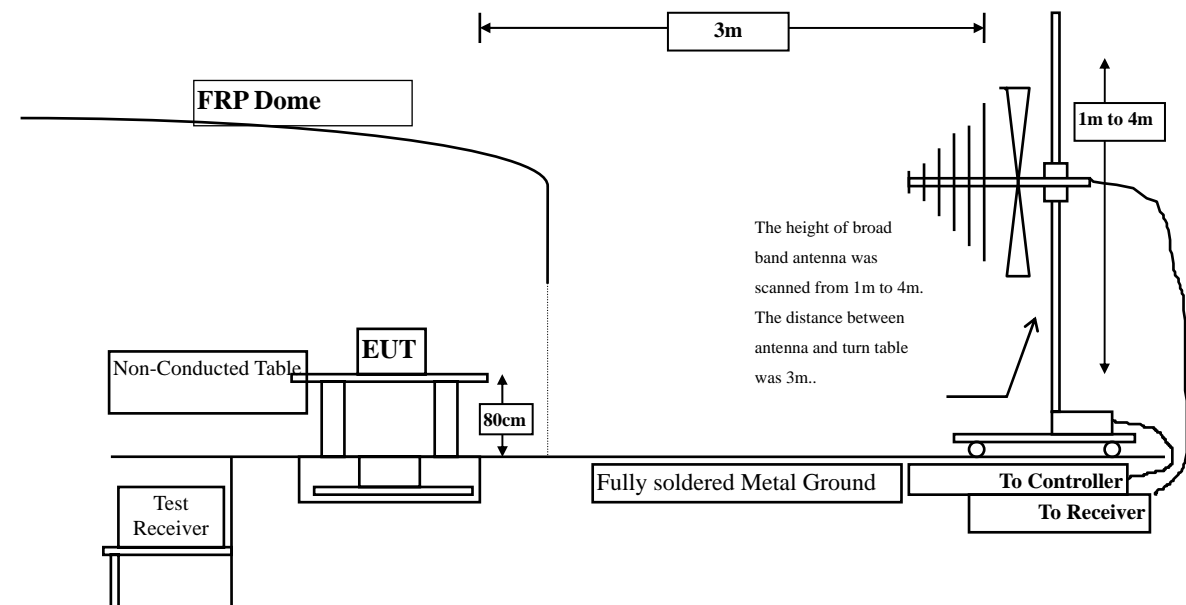

Radiated Emission Above 1GHz

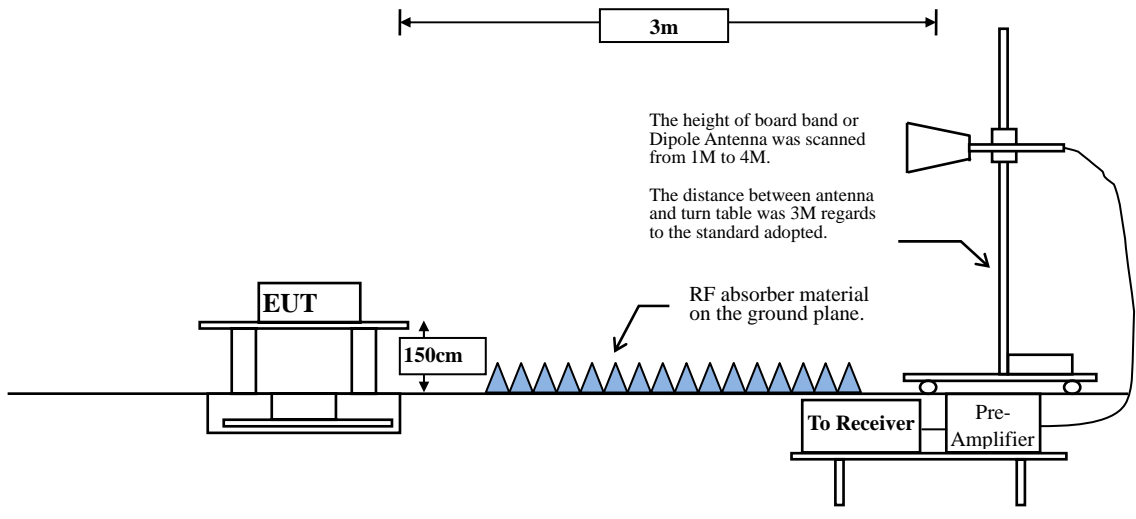

3.2. Limits

➤ Fundamental and Harmonics Emission Limits

Fundamental Frequency MHz	Field Strength of Fundamental	Field Strength of Spurious Emission
40.66-40.70	2250	225
70-130	1250	125
130-174	1250-3750	125-375
174-260	3750	375
260-470	3750-12500	375-1250
above 470	12500	1250

- Remarks :
1. RF Voltage (dBuV) = 20 log RF Voltage (uV)
 2. Distance refers to the distance in meters between the measuring instrument antenna and the closed point of any part of the device or system.
 3. The emission limit in this paragraph is based on measurement instrumentation employing an average detector.

➤ Spurious electric field strength limits

FCC Part 15 Subpart C Paragraph 15.209 Limits			
Frequency MHz	uV/m	dBuV/m	Measurement distance (meter)
0.009-0.490	2400/F(kHz)	See Remark ¹	300
0.490-1.705	24000/F(kHz)	See Remark ¹	30
1.705-30	30	29.5	30
30-88	100	40	3
88-216	150	43.5	3
216-960	200	46	3
Above 960	500	54	3

- Remarks :
1. RF Voltage (dBuV) = 20 log RF Voltage (uV)
 2. In the Above Table, the tighter limit applies at the band edges.
 3. Distance refers to the distance in meters between the measuring instrument antenna and the closed point of any part of the device or system.

3.3. Test Procedure

Measuring the frequency range below 1GHz, the EUT is placed on a turn table which is 0.8 meter above ground, when measuring the frequency range above 1GHz, the EUT is placed on a turn table which is 1.5 meter above ground.

The EUT was positioned such that the distance from antenna to the EUT was 3 meters.

The turn table can rotate 360 degrees to determine the position of the maximum emission level.

The antenna can move up and down between 1 meter and 4 meters to find out the maximum emission level.

Both horizontal and vertical polarization of the antenna are set on measurement. In order to find the maximum emission, all of the interface cables must be manipulated according to ANSI C63.10, 2013 on radiated measurement.

On the field strength of fundamental and harmonics, the limits shown are based on measuring equipment employing an average detector function. As an alternative, compliance with the limits may be based on the use of measurement instrumentation with a CISPR quasi-peak detector.

On the field strength of spurious electric, on any frequency or frequencies below or equal to 1000 MHz, the limits shown are based on measuring equipment employing a quasi-peak detector function and on any frequency or frequencies above 1000 MHz the radiated limits shown are based upon the use of measurement instrumentation employing an average detector function.

When average radiated emission measurement are included emission measurement below 1000 MHz, there also is a limit on the radio frequency emissions, as measured using instrumentation with a peak detector function, corresponding to 20 dB above the maximum permitted average limit.

The bandwidth The resolution bandwidth below 30MHz setting on the field strength meter is 9kHz and below 1GHz setting on the field strength meter is 120 kHz and above 1GHz is 1MHz.

3.4. Test Specification

According to FCC Part 15 Subpart C Paragraph 15.231

3.5. Uncertainty

± 4.08 dB above 1GHz

± 4.22 dB below 1GHz

3.6. Test Result

Product	RRNM-IDG		
Test Item	Fundamental Radiated Emission		
Test Mode	Mode 1: Transmit (433.2MHz)		
Date of Test	2016/12/27	Test Site	No.3 OATS

Fundamental Power (X-Line)

Peak Detector:

Frequency MHz	Correct Factor dB	Reading Level dBuV	Measurement Level dBuV/m	Margin dB	Limit dBuV/m
------------------	-------------------------	--------------------------	--------------------------------	--------------	-----------------

Horizontal

433.200	-9.011	86.820	77.809	-22.991	100.800
---------	--------	--------	--------	---------	---------

Vertical

433.200	-9.011	78.100	69.089	-31.711	100.800
---------	--------	--------	--------	---------	---------

Average Detector:

Frequency MHz	Correct Factor dB	Reading Level dBuV	Measurement Level dBuV/m	Margin dB	Limit dBuV/m
------------------	-------------------------	--------------------------	--------------------------------	--------------	-----------------

Horizontal

433.200	-9.011	86.000	76.989	-3.811	80.800
---------	--------	--------	--------	--------	--------

Vertical

433.200	-9.011	77.300	68.289	-12.511	80.800
---------	--------	--------	--------	---------	--------

Note:

1. Measurement Level = Reading Level + Correct Factor
2. Average Limit=20log(41.667(433.2)-7083.333)=80.80 dBuV 、 Peak Limit=100.80 dBuV

Product	RRNM-IDG		
Test Item	Fundamental Radiated Emission		
Test Mode	Mode 1: Transmit (433.2MHz)		
Date of Test	2016/12/27	Test Site	No.3 OATS

Fundamental Power (Y-Line)

Peak Detector:

Frequency MHz	Correct Factor dB	Reading Level dBuV	Measurement Level dBuV/m	Margin dB	Limit dBuV/m
------------------	-------------------------	--------------------------	--------------------------------	--------------	-----------------

Horizontal

433.200	-9.011	83.460	74.449	-26.351	100.800
---------	--------	--------	--------	---------	---------

Vertical

433.200	-9.011	89.410	80.399	-20.401	100.800
---------	--------	--------	--------	---------	---------

Average Detector:

Frequency MHz	Correct Factor dB	Reading Level dBuV	Measurement Level dBuV/m	Margin dB	Limit dBuV/m
------------------	-------------------------	--------------------------	--------------------------------	--------------	-----------------

Horizontal

433.200	-9.011	82.600	73.589	-7.211	80.800
---------	--------	--------	--------	--------	--------

Vertical

433.200	-9.011	88.600	79.589	-1.211	80.800
---------	--------	--------	--------	--------	--------

Note:

1. Measurement Level = Reading Level + Correct Factor
2. Average Limit=20log(41.667(433.2)-7083.333)=80.80 dBuV 、 Peak Limit=100.80 dBuV

Product	RRNM-IDG		
Test Item	Fundamental Radiated Emission		
Test Mode	Mode 1: Transmit (433.2MHz)		
Date of Test	2016/12/27	Test Site	No.3 OATS

Fundamental Power (Z-Line)

Peak Detector:

Frequency MHz	Correct Factor dB	Reading Level dBuV	Measurement Level dBuV/m	Margin dB	Limit dBuV/m
------------------	-------------------------	--------------------------	--------------------------------	--------------	-----------------

Horizontal

433.200	-9.011	84.900	75.889	-24.911	100.800
---------	--------	--------	--------	---------	---------

Vertical

433.200	-9.011	90.040	81.029	-19.771	100.800
---------	--------	--------	--------	---------	---------

Average Detector:

Frequency MHz	Correct Factor dB	Reading Level dBuV	Measurement Level dBuV/m	Margin dB	Limit dBuV/m
------------------	-------------------------	--------------------------	--------------------------------	--------------	-----------------

Horizontal

433.200	-9.011	84.080	75.069	-5.731	80.800
---------	--------	--------	--------	--------	--------

Vertical

433.200	-9.011	89.210	80.199	-0.601	80.800
---------	--------	--------	--------	--------	--------

Note:

1. Measurement Level = Reading Level + Correct Factor
2. Average Limit=20log(41.667(433.2)-7083.333)=80.80 dBuV 、 Peak Limit=100.80 dBuV

Product	RRNM-IDG		
Test Item	Fundamental Radiated Emission		
Test Mode	Mode 1: Transmit (434.64MHz)		
Date of Test	2016/12/27	Test Site	No.3 OATS

Fundamental Power (X-Line)

Peak Detector:

Frequency MHz	Correct Factor dB	Reading Level dBuV	Measurement Level dBuV/m	Margin dB	Limit dBuV/m
------------------	-------------------------	--------------------------	--------------------------------	--------------	-----------------

Horizontal

434.640	-8.977	87.760	78.783	-22.057	100.840
---------	--------	--------	--------	---------	---------

Vertical

434.640	-8.977	78.370	69.393	-31.447	100.840
---------	--------	--------	--------	---------	---------

Average Detector:

Frequency MHz	Correct Factor dB	Reading Level dBuV	Measurement Level dBuV/m	Margin dB	Limit dBuV/m
------------------	-------------------------	--------------------------	--------------------------------	--------------	-----------------

Horizontal

434.640	-8.977	86.880	77.903	-2.937	80.840
---------	--------	--------	--------	--------	--------

Vertical

434.640	-8.977	77.500	68.523	-12.317	80.840
---------	--------	--------	--------	---------	--------

Note:

1. Measurement Level = Reading Level + Correct Factor
2. Average Limit=20log(41.667(434.64)-7083.333)=80.84 dBuV 、 Peak Limit=100.84 dBuV

Product	RRNM-IDG		
Test Item	Fundamental Radiated Emission		
Test Mode	Mode 1: Transmit (434.64MHz)		
Date of Test	2016/12/27	Test Site	No.3 OATS

Fundamental Power (Y-Line)

Peak Detector:

Frequency MHz	Correct Factor dB	Reading Level dBuV	Measurement Level dBuV/m	Margin dB	Limit dBuV/m
------------------	-------------------------	--------------------------	--------------------------------	--------------	-----------------

Horizontal

434.640	-8.977	83.400	74.423	-26.417	100.840
---------	--------	--------	--------	---------	---------

Vertical

434.640	-8.977	90.780	81.803	-19.037	100.840
---------	--------	--------	--------	---------	---------

Average Detector:

Frequency MHz	Correct Factor dB	Reading Level dBuV	Measurement Level dBuV/m	Margin dB	Limit dBuV/m
------------------	-------------------------	--------------------------	--------------------------------	--------------	-----------------

Horizontal

434.640	-8.977	82.600	73.623	-7.217	80.840
---------	--------	--------	--------	--------	--------

Vertical

434.640	-8.977	89.240	80.263	-0.577	80.840
---------	--------	--------	--------	--------	--------

Note:

1. Measurement Level = Reading Level + Correct Factor
2. Average Limit=20log(41.667(434.64)-7083.333)=80.84 dBuV 、 Peak Limit=100.84 dBuV

Product	RRNM-IDG		
Test Item	Fundamental Radiated Emission		
Test Mode	Mode 1: Transmit (434.64MHz)		
Date of Test	2016/12/27	Test Site	No.3 OATS

Fundamental Power (Z-Line)

Peak Detector:

Frequency MHz	Correct Factor dB	Reading Level dBuV	Measurement Level dBuV/m	Margin dB	Limit dBuV/m
------------------	-------------------------	--------------------------	--------------------------------	--------------	-----------------

Horizontal

434.640	-8.977	84.380	75.403	-25.437	100.840
---------	--------	--------	--------	---------	---------

Vertical

434.640	-8.977	89.120	80.143	-20.697	100.840
---------	--------	--------	--------	---------	---------

Average Detector:

Frequency MHz	Correct Factor dB	Reading Level dBuV	Measurement Level dBuV/m	Margin dB	Limit dBuV/m
------------------	-------------------------	--------------------------	--------------------------------	--------------	-----------------

Horizontal

434.640	-8.977	83.390	74.413	-6.427	80.840
---------	--------	--------	--------	--------	--------

Vertical

434.640	-8.977	88.100	79.123	-1.717	80.840
---------	--------	--------	--------	--------	--------

Note:

1. Measurement Level = Reading Level + Correct Factor
2. Average Limit=20log(41.667(434.64)-7083.333)=80.84 dBuV 、 Peak Limit=100.84 dBuV

Product	RRNM-IDG		
Test Item	Harmonic Radiated Emission		
Test Mode	Mode 1: Transmit (433.2MHz)		
Date of Test	2016/12/23	Test Site	CB8

Frequency MHz	Correct Factor dB	Reading Level dBuV	Measurement Level dBuV/m	Margin dB	Limit dBuV/m
Horizontal					
Peak					
1299.600	-11.526	43.620	32.095	-41.905	74.000
1732.800	-9.481	39.290	29.810	-44.190	74.000
2166.000	-7.150	28.290	21.140	-52.860	74.000
2599.200	-6.316	36.460	30.145	-43.855	74.000
3032.400	-5.735	38.760	33.025	-40.975	74.000
3465.600	-5.616	30.840	25.223	-48.777	74.000
3898.800	-5.301	34.900	29.599	-44.401	74.000
4332.000	-4.344	31.560	27.216	-46.784	74.000
Average					
--					54.000

Note:

1. All Readings below 1GHz are Quasi-Peak, above 1GHz are performed with peak and/or average measurements as necessary.
2. Peak measurements: RBW = 1MHz, VBW = 3 MHz, Sweep: Auto.
3. Average measurements: RBW = 1MHz, VBW = 10 Hz, Sweep: Auto.
4. Measurement Level = Reading Level + Correct Factor.
5. Correct Factor = Antenna factor + Cable loss – Amplifier gain.
6. The average measurement was not performed when the peak measured data under the limit of average detection.
7. The emission levels of other frequencies are very lower than the limit and not show in test report.

Product	RRNM-IDG		
Test Item	Harmonic Radiated Emission		
Test Mode	Mode 1: Transmit (433.2MHz)		
Date of Test	2016/12/23	Test Site	CB8

Frequency MHz	Correct Factor dB	Reading Level dBuV	Measurement Level dBuV/m	Margin dB	Limit dBuV/m
Vertical Peak					
1299.600	-11.526	45.540	34.015	-39.985	74.000
1732.800	-9.481	39.690	30.210	-43.790	74.000
2166.000	-7.150	28.040	20.890	-53.110	74.000
2599.200	-6.316	37.720	31.405	-42.595	74.000
3032.400	-5.735	38.790	33.055	-40.945	74.000
3465.600	-5.616	29.520	23.903	-50.097	74.000
3898.800	-5.301	35.640	30.339	-43.661	74.000
4332.000	-4.344	30.710	26.366	-47.634	74.000
Average					
--					54.000

Note:

1. All Readings below 1GHz are Quasi-Peak, above 1GHz are performed with peak and/or average measurements as necessary.
2. Peak measurements: RBW = 1MHz, VBW = 3 MHz, Sweep: Auto.
3. Average measurements: RBW = 1MHz, VBW = 10 Hz, Sweep: Auto.
4. Measurement Level = Reading Level + Correct Factor.
5. Correct Factor = Antenna factor + Cable loss – Amplifier gain.
6. The average measurement was not performed when the peak measured data under the limit of average detection.
7. The emission levels of other frequencies are very lower than the limit and not show in test report.

Product	RRNM-IDG		
Test Item	Harmonic Radiated Emission		
Test Mode	Mode 1: Transmit (434.64MHz)		
Date of Test	2016/12/23	Test Site	CB8

Frequency MHz	Correct Factor dB	Reading Level dBuV	Measurement Level dBuV/m	Margin dB	Limit dBuV/m
Horizontal					
Peak					
1303.920	-11.518	43.020	31.501	-42.499	74.000
1738.560	-9.437	37.880	28.444	-45.556	74.000
2173.200	-7.137	28.330	21.193	-52.807	74.000
2607.840	-6.301	35.040	28.740	-45.260	74.000
3042.480	-5.734	38.620	32.886	-41.114	74.000
3477.120	-5.609	30.260	24.650	-49.350	74.000
3911.760	-5.293	37.260	31.967	-42.033	74.000
4364.400	-4.264	31.010	26.746	-47.254	74.000
Average					
--					54.000

Note:

- All Readings below 1GHz are Quasi-Peak, above 1GHz are performed with peak and/or average measurements as necessary.
- Peak measurements: RBW = 1MHz, VBW = 3 MHz, Sweep: Auto.
- Average measurements: RBW = 1MHz, VBW = 10 Hz, Sweep: Auto.
- Measurement Level = Reading Level + Correct Factor.
- Correct Factor = Antenna factor + Cable loss – Amplifier gain.
- The average measurement was not performed when the peak measured data under the limit of average detection.
- The emission levels of other frequencies are very lower than the limit and not show in test report.

Product	RRNM-IDG		
Test Item	Harmonic Radiated Emission		
Test Mode	Mode 1: Transmit (434.64MHz)		
Date of Test	2016/12/23	Test Site	CB8

Frequency MHz	Correct Factor dB	Reading Level dBuV	Measurement Level dBuV/m	Margin dB	Limit dBuV/m
Vertical					
Peak					
1303.920	-11.518	46.300	34.781	-39.219	74.000
1738.560	-9.437	47.960	38.524	-35.476	74.000
2173.200	-7.137	27.770	20.633	-53.367	74.000
2607.840	-6.301	34.240	27.940	-46.060	74.000
3042.480	-5.734	40.260	34.526	-39.474	74.000
3477.120	-5.609	29.050	23.440	-50.560	74.000
3911.760	-5.293	38.310	33.017	-40.983	74.000
4346.400	-4.304	30.820	26.516	-47.484	74.000
Average					
--					54.000

Note:

1. All Readings below 1GHz are Quasi-Peak, above 1GHz are performed with peak and/or average measurements as necessary.
2. Peak measurements: RBW = 1MHz, VBW = 3 MHz, Sweep: Auto.
3. Average measurements: RBW = 1MHz, VBW = 10 Hz, Sweep: Auto.
4. Measurement Level = Reading Level + Correct Factor.
5. Correct Factor = Antenna factor + Cable loss – Amplifier gain.
6. The average measurement was not performed when the peak measured data under the limit of average detection.
7. The emission levels of other frequencies are very lower than the limit and not show in test report.

Product	RRNM-IDG		
Test Item	General Radiated Emission		
Test Mode	Mode 1: Transmit (433.2MHz)		
Date of Test	2016/12/23	Test Site	No.3 OATS

Frequency MHz	Correct Factor dB	Reading Level dBuV	Measurement Level dBuV/m	Margin dB	Limit dBuV/m
Horizontal					
Quasi-Peak					
459.261	-6.472	24.161	17.689	-28.311	46.000
569.509	-4.422	27.115	22.693	-23.307	46.000
714.466	-2.139	23.764	21.625	-24.375	46.000
795.014	-1.104	26.966	25.862	-20.138	46.000
866.443	-0.031	42.807	42.776	-3.224	46.000
933.731	0.802	25.507	26.309	-19.691	46.000
Vertical					
Quasi-Peak					
451.821	-6.590	25.562	18.972	-27.028	46.000
534.830	-5.213	24.391	19.178	-26.822	46.000
682.247	-2.711	23.944	21.233	-24.767	46.000
782.594	-1.197	23.038	21.841	-24.159	46.000
866.383	-0.032	33.851	33.819	-12.181	46.000
953.561	1.027	21.814	22.841	-23.159	46.000

Note:

- All Readings below 1GHz are Quasi-Peak, above 1GHz are performed with peak and/or average measurements as necessary.
- Peak measurements: RBW = 1MHz, VBW = 3 MHz, Sweep: Auto.
- Average measurements: RBW = 1MHz, VBW = 10 Hz, Sweep: Auto.
- Measurement Level = Reading Level + Correct Factor.
- Correct Factor = Antenna factor + Cable loss – Amplifier gain.
- The average measurement was not performed when the peak measured data under the limit of average detection.
- The emission levels of other frequencies are very lower than the limit and not show in test report.
- No emission found between lowest internal used/generated frequency to 30MHz.

Product	RRNM-IDG		
Test Item	General Radiated Emission		
Test Mode	Mode 1: Transmit (434.64MHz)		
Date of Test	2016/12/23	Test Site	No.3 OATS

Frequency MHz	Correct Factor dB	Reading Level dBuV	Measurement Level dBuV/m	Margin dB	Limit dBuV/m
Horizontal					
Quasi-Peak					
428.302	-7.124	24.632	17.508	-28.492	46.000
565.819	-4.518	25.773	21.255	-24.745	46.000
679.787	-2.749	26.310	23.561	-22.439	46.000
768.135	-1.305	25.333	24.029	-21.971	46.000
869.233	0.008	40.928	40.936	-5.064	46.000
934.991	0.816	24.584	25.400	-20.600	46.000
Vertical					
Quasi-Peak					
315.564	-9.807	26.966	17.160	-28.840	46.000
488.991	-6.017	25.891	19.874	-26.126	46.000
621.558	-3.467	22.195	18.728	-27.272	46.000
757.815	-1.385	22.039	20.655	-25.345	46.000
869.233	0.008	38.563	38.571	-7.429	46.000
937.451	0.843	26.758	27.601	-18.399	46.000

Note:

1. All Readings below 1GHz are Quasi-Peak, above 1GHz are performed with peak and/or average measurements as necessary.
2. Peak measurements: RBW = 1MHz, VBW = 3 MHz, Sweep: Auto.
3. Average measurements: RBW = 1MHz, VBW = 10 Hz, Sweep: Auto.
4. Measurement Level = Reading Level + Correct Factor.
5. Correct Factor = Antenna factor + Cable loss – Amplifier gain.
6. The average measurement was not performed when the peak measured data under the limit of average detection.
7. The emission levels of other frequencies are very lower than the limit and not show in test report.
8. No emission found between lowest internal used/generated frequency to 30MHz.

4. Transmit time

4.1. Test Setup

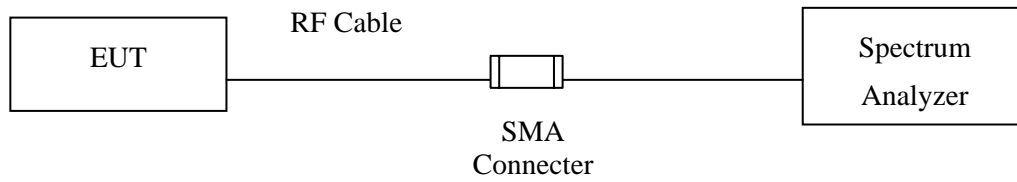

4.2. Limits

A manually operated transmitter shall employ a switch that will automatically deactivate the transmitter within not more than 5 seconds of being released.

A transmitter activated automatically shall cease transmission within 5 seconds after activation.

4.3. Test Specification

According to FCC Part 15 Subpart C Paragraph 15.231

4.4. Uncertainty

$\pm 2.31\text{ms}$

4.5. Test Result

Product RRNM-IDG
 Test Item Transmit time
 Test Site CB3
 Test Mode Mode 1: Transmit (433.2MHz)

Channel No.	Frequency (MHz)	Measurement Value (Sec)	Limit (Sec)	Result
1	433.2	1.9275	< 5	Pass

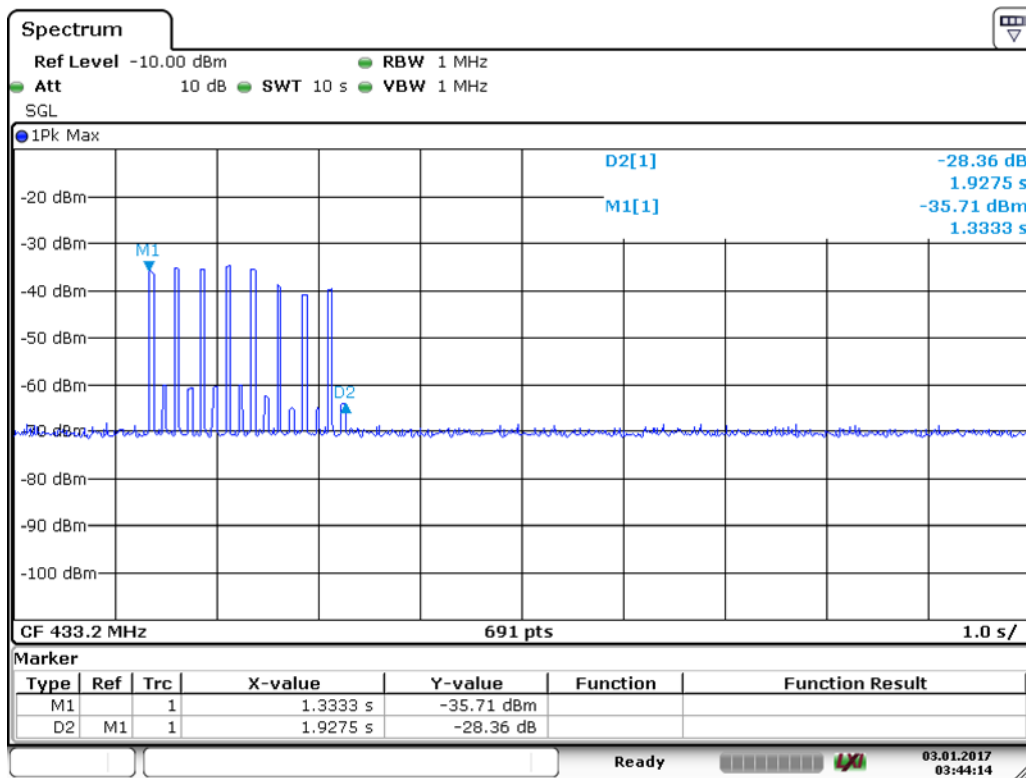

Date: 3.JAN.2017 03:44:14

Product RRNM-IDG
 Test Item Transmit time
 Test Site CB3
 Test Mode Mode 1: Transmit (434.64MHz)

Channel No.	Frequency (MHz)	Measurement Value (Sec)	Limit (Sec)	Result
2	434.64	1.9275	< 5	Pass

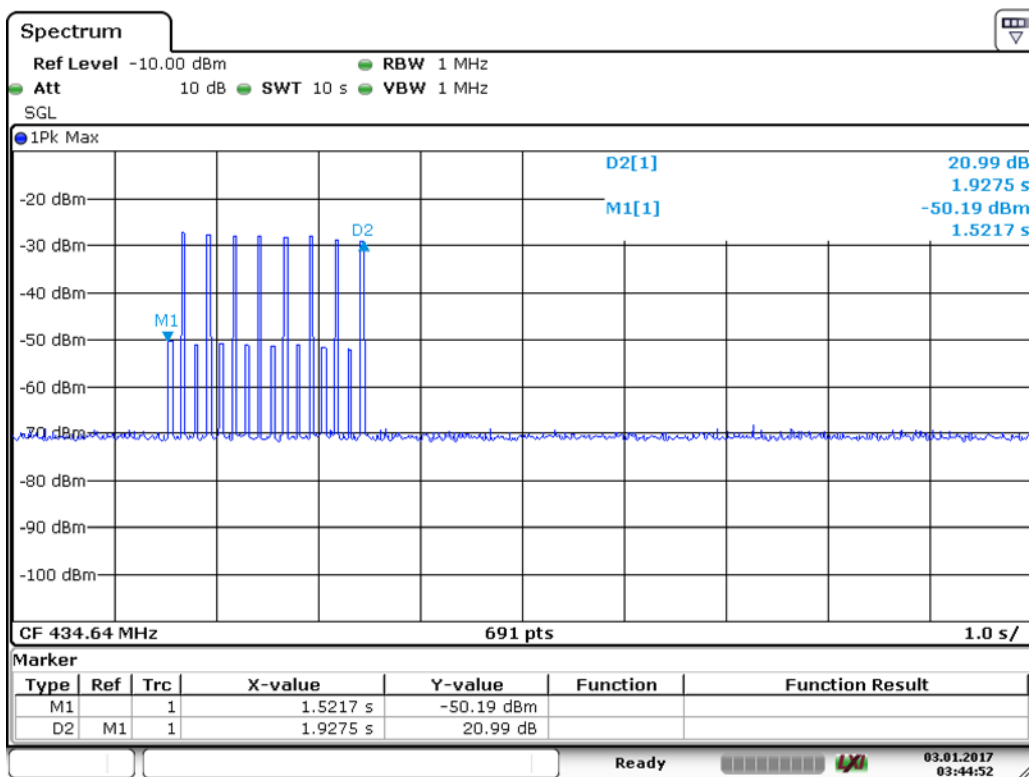

Date: 3. JAN.2017 03:44:52

5. Occupied Bandwidth

5.1. Test Setup

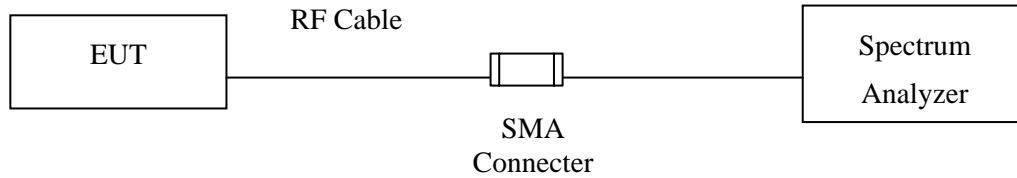

5.2. Limits

The bandwidth of the emission shall be no wider than 0.25% of the center frequency for devices operating above 70MHz and below 900MHz. For devices operating above 900MHz, the emission shall be no wider than 0.5% of the center frequency. Bandwidth is determined at the points 20 dB down from the modulated carrier

5.3. Test Specification

According to FCC Part 15 Subpart C Paragraph 15.231

5.4. Uncertainty

$\pm 283\text{Hz}$

5.5. Test Result

Product RRNM-IDG
 Test Item Occupied Bandwidth
 Test Site CB3
 Test Mode Mode 1: Transmit (433.2MHz)

Channel No.	Frequency (MHz)	Measurement Value (MHz)	Limit (MHz)	Result
1	433.2	0.0869	1.0830	Pass

Note: Limit = 433.2MHz * 0.25%= 1.083MHz

Figure Channel 1:

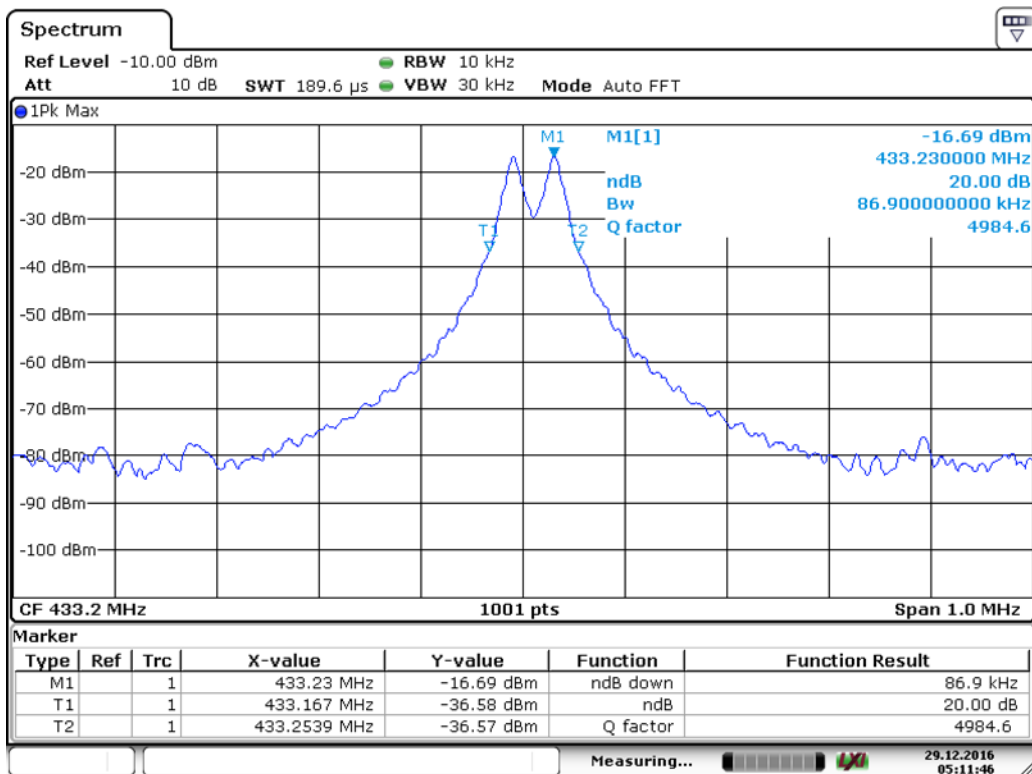

Date: 29.DEC.2016 05:11:47

Product RRNM-IDG
 Test Item Occupied Bandwidth
 Test Site CB3
 Test Mode Mode 1: Transmit (434.64MHz)

Channel No.	Frequency (MHz)	Measurement Value (MHz)	Limit (MHz)	Result
2	434.64	0.0869	1.0866	Pass

Note: Limit = 434.64MHz * 0.25%= 1.0866MHz

Figure Channel 2:

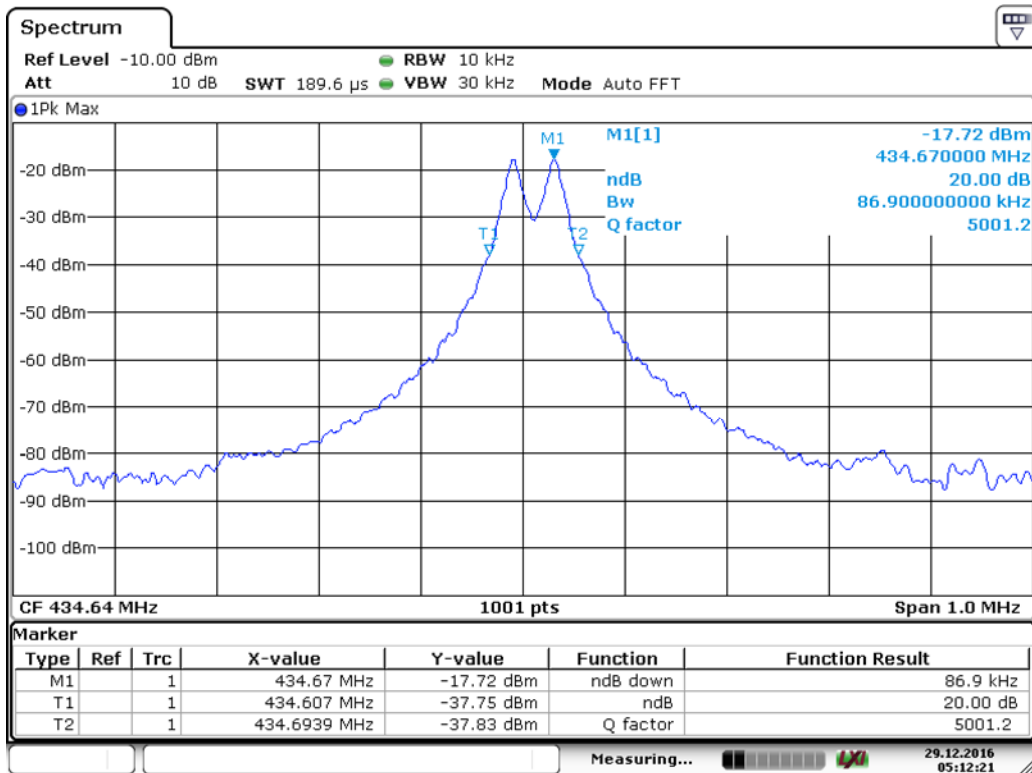

Date: 29.DEC.2016 05:12:21

Attachment 1 : EUT Test Photographs

Attachment 2 : EUT Detailed Photographs