



A D T

FCC TEST REPORT (15.407)

REPORT NO.: RF110607C27-1

MODEL NO.: SWW1890R /27, SWW1810R /27
(refer to item 3.1 for more details)

FCC ID: YG7ZRF32200

RECEIVED: Jun. 02, 2011

TESTED: Jun. 02 ~ Jun. 28, 2011

ISSUED: Jul. 07, 2011

APPLICANT: Zinwell Corporation

ADDRESS: 7F., No.512, Yuanshan Rd., Zhonghe Dist., New Taipei City 235, Taiwan (R.O.C.)

ISSUED BY: Bureau Veritas Consumer Products Services (H.K.) Ltd., Taoyuan Branch

LAB ADDRESS: No. 47, 14th Ling, Chia Pau Tsuen, Lin Kou Hsiang, Taipei Hsien 244, Taiwan, R.O.C.

TEST LOCATION: No. 19, Hwa Ya 2nd Rd, Wen Hwa Tsuen, Kwei Shan Hsiang, Taoyuan Hsien 333, Taiwan, R.O.C.

This test report consists of 64 pages in total. It may be duplicated completely for legal use with the approval of the applicant. It should not be reproduced except in full, without the written approval of our laboratory. The client should not use it to claim product certification, approval, or endorsement by TAF or any government agency. The test results in the report only apply to the tested sample.





TABLE OF CONTENTS

RELEASE CONTROL RECORD.....	4
1. CERTIFICATION.....	5
2. SUMMARY OF TEST RESULTS	6
2.1 MEASUREMENT UNCERTAINTY.....	6
3. GENERAL INFORMATION.....	7
3.1 GENERAL DESCRIPTION OF EUT	7
3.2 DESCRIPTION OF TEST MODES	9
3.2.1 CONFIGURATION OF SYSTEM UNDER TEST	10
3.2.2 TEST MODE APPLICABILITY AND TESTED CHANNEL DETAIL	11
3.3 GENERAL DESCRIPTION OF APPLIED STANDARDS	13
3.4 DESCRIPTION OF SUPPORT UNITS	13
4. TEST TYPES AND RESULTS	14
4.1 RADIATED EMISSION MEASUREMENT	14
4.1.1 LIMITS OF RADIATED EMISSION MEASUREMENT.....	14
4.1.2 LIMITS OF UNWANTED EMISSION OUT OF THE RESTRICTED BANDS	14
4.1.3 TEST INSTRUMENTS.....	15
4.1.4 TEST PROCEDURES	16
4.1.5 DEVIATION FROM TEST STANDARD.....	16
4.1.6 TEST SETUP	17
4.1.7 EUT OPERATING CONDITION.....	17
4.1.8 TEST RESULTS	18
4.2 CONDUCTED EMISSION MEASUREMENT	26
4.2.1 LIMITS OF CONDUCTED EMISSION MEASUREMENT	26
4.2.2 TEST INSTRUMENTS.....	26
4.2.3 TEST PROCEDURES	27
4.2.4 DEVIATION FROM TEST STANDARD.....	27
4.2.5 TEST SETUP	28
4.2.6 EUT OPERATING CONDITIONS	28
4.2.7 TEST RESULTS	29
4.3 MAXIMUM CONDUCTED OUTPUT POWER MEASUREMENT	35
4.3.1 LIMITS OF MAXIMUM CONDUCTED OUTPUT POWER MEASUREMENT.....	35
4.3.2 TEST INSTRUMENTS.....	35
4.3.3 TEST PROCEDURE.....	36
4.3.4 DEVIATION FROM TEST STANDARD.....	36
4.3.5 TEST SETUP	36
4.3.6 EUT OPERATING CONDITIONS	36



A D T

4.3.7	TEST RESULTS	37
4.4	PEAK POWER EXCURSION MEASUREMENT	40
4.4.1	LIMITS OF PEAK POWER EXCURSION MEASUREMENT	40
4.4.2	TEST INSTRUMENTS.....	40
4.4.3	TEST PROCEDURE.....	40
4.4.4	DEVIATION FROM TEST STANDARD.....	41
4.4.5	TEST SETUP	41
4.4.6	EUT OPERATING CONDITIONS	41
4.4.7	TEST RESULTS	42
4.5	PEAK POWER SPECTRAL DENSITY MEASUREMENT	46
4.5.1	LIMITS OF PEAK POWER SPECTRAL DENSITY MEASUREMENT	46
4.5.2	TEST INSTRUMENTS.....	46
4.5.3	TEST PROCEDURES	46
4.5.4	DEVIATION FROM TEST STANDARD.....	47
4.5.5	TEST SETUP	47
4.5.6	EUT OPERATING CONDITIONS	47
4.5.7	TEST RESULTS	48
4.6	FREQUENCY STABILITY.....	50
4.6.1	LIMITS OF FREQUENCY STABILITY MEASUREMENT	50
4.6.2	TEST INSTRUMENTS.....	50
4.6.3	TEST PROCEDURE.....	50
4.6.4	DEVIATION FROM TEST STANDARD.....	51
4.6.5	TEST SETUP	51
4.6.6	EUT OPERATING CONDITION.....	51
4.6.7	TEST RESULTS	52
4.7	BAND EDGES MEASUREMENT	53
4.7.1	TEST INSTRUMENTS.....	53
4.7.2	TEST PROCEDURE.....	53
4.7.3	EUT OPERATING CONDITION.....	53
4.7.4	TEST RESULTS	54
5.	PHOTOGRAPHS OF THE TEST CONFIGURATION.....	62
6.	INFORMATION ON THE TESTING LABORATORIES	63
7.	APPENDIX A - MODIFICATIONS RECORDERS FOR ENGINEERING CHANGES TO THE EUT BY THE LAB.....	64



A D T

RELEASE CONTROL RECORD

ISSUE NO.	REASON FOR CHANGE	DATE ISSUED
Original release	N/A	Jul. 07, 2011



1. CERTIFICATION

PRODUCT: Wireless HD Net Connect Receiver, Wireless HD AV Connect Receiver (refer to item 3.1 for more details)

MODEL: SWW1890R /27, SWW1810R /27 (refer to item 3.1 for more details)

BRAND: PHILIPS (refer to item 3.1 for more details)

APPLICANT: Zinwell Corporation

TEST SAMPLE: ENGINEERING SAMPLE

TESTED: Jun. 02 ~ Jun. 28, 2011

STANDARDS: **FCC Part 15, Subpart E (Section 15.407)**

ANSI C63.4-2003

ANSI C63.10-2009

The above equipment (model: SWW1890R /27, SWW1810R /27, WHD100R, WHD200R) has been tested by **Bureau Veritas Consumer Products Services (H.K.) Ltd., Taoyuan Branch**, and found compliance with the requirement of the above standards. The test record, data evaluation & Equipment Under Test (EUT) configurations represented herein are true and accurate accounts of the measurements of the sample's EMC characteristics under the conditions specified in this report.

PREPARED BY :  , DATE : Jul. 07, 2011
Joanna Wang / Senior Specialist

APPROVED BY :  , DATE : Jul. 07, 2011
Gary Chang / Assistant Manager

2. SUMMARY OF TEST RESULTS

The EUT has been tested according to the following specifications:

APPLIED STANDARD: FCC PART 15, SUBPART E (SECTION 15.407)			
STANDARD SECTION	TEST TYPE AND LIMIT	RESULT	REMARK
15.407(b)(5)	AC Power Conducted Emission	PASS	Meet the requirement of limit. Minimum passing margin is -10.73dB at 15.000MHz.
15.407(b)(1/2/3)(b)(5)	Electric Field Strength Spurious Emissions, 30MHz ~ 40000MHz	PASS	Meet the requirement of limit. Minimum passing margin is -1.9dB at 142.67MHz.
15.407(a)(1/2/3)	Peak Transmit Power	PASS	Meet the requirement of limit.
15.407(a)(6)	Peak Power Excursion	PASS	Meet the requirement of limit.
15.407(a)(1/2/3)	Peak Power Spectral Density	PASS	Meet the requirement of limit.
15.407(g)	Frequency Stability	PASS	Meet the requirement of limit.
15.203	Antenna Requirement	PASS	No antenna connector is used.

2.1 MEASUREMENT UNCERTAINTY

Where relevant, the following measurement uncertainty levels have been estimated for tests performed on the EUT as specified in CISPR 16-4-2:

MEASUREMENT	FREQUENCY	UNCERTAINTY
Conducted emissions	150kHz~30MHz	2.44 dB
Radiated emissions	30MHz ~ 200MHz	2.93dB
	200MHz ~1000MHz	2.95dB
	1GHz ~ 18GHz	2.26dB
	18GHz ~ 40GHz	1.94dB

This uncertainty represents an expanded uncertainty expressed at approximately the 95% confidence level using a coverage factor of $k = 2$.

3. GENERAL INFORMATION

3.1 GENERAL DESCRIPTION OF EUT

EUT	Wireless HD Net Connect Receiver, Wireless HD AV Connect Receiver (refer to NOTE for more details)
MODEL NO.	SWW1890R /27, SWW1810R /27 (refer to NOTE for more details)
FCC ID	YG7ZRF32200
POWER SUPPLY	5Vdc
MODULATION TECHNOLOGY	OFDM
TRANSFER RATE	100Kbps transmission, 1Gbps reception
OPERATING FREQUENCY	5180 ~ 5240MHz
NUMBER OF CHANNEL	4 for WHDI (20MHz) 2 for WHDI (40MHz)
OUTPUT POWER	40.7mW
ANTENNA TYPE	Printed antenna with 6.2dBi gain x 2 (1TX, 2RX) Chip antenna with 6.2dBi gain x 3 (3RX)
ANTENNA CONNECTOR	NA
I/O PORTS	Refer to user's manual
DATA CABLE	1.5m shielded HDMI cable with one core 1.0m IR cable without core
ACCESSORY DEVICES	Adapter

NOTE:

- The following models are provided to this EUT.

BRAND	MODEL	HDMI OUT	USB PORT	IR IN	DESCRIPTION
PHILIPS	SWW1890R /27	√	X	X	Wireless HD Net Connect Receiver
	SWW1810R /27	√	X	√	Wireless HD AV Connect Receiver
ZINWELL	WHD100R	√	√	X	Wireless HD Net Connect Receiver
	WHD200R	√	√	X	Wireless HD AV Connect Receiver

BRAND	PHILIPS		ZINWELL	
	MODEL	SWW1890R /27	SWW1810R /27	WHD100R
IR receiver	X	X	√	√
IR external board + IR extender board	X	√	X	X
IR Sensor Extender	X	√	X	X
Power Adapter	3.5mm DC Jack Output: 5Vdc, 2A	3.5mm DC Jack Output: 5Vdc, 2A	Mini USB Output: 5Vdc, 1.5A	Mini USB Output: 5Vdc, 1.5A
HDMI (Output) cable	With 1 core	With 1 core	With 1 core	With 1 core

2. The EUT is a Wireless HD Net Connect Receiver, Wireless HD AV Connect Receiver. The test data are separated into following test reports.

	TEST STANDARD	REFERENCE REPORT
WHDI (20MHz), WHDI (40MHz) (5745~5805MHz)	FCC Part 15, Subpart C (Section 15.247)	RF110607C27
WHDI (20MHz), WHDI (40MHz) (5180~5240MHz)	FCC Part 15, Subpart E (Section 15.407)	RF110607C27-1

3. The EUT incorporates a MIMO function. Physically, the EUT provides one completed transmitter and five receivers.

MODULATION MODE	TX FUNCTION
WHDI (20MHz)	1TX
WHDI (40MHz)	1TX

4. The frequency bands used in this EUT are listed as follows:

FREQUENCY BAND (MHz)	5180~5240	5745~5805
WHDI (20MHz)	√	√
WHDI (40MHz)	√	√

5. The EUT was powered by the following adapters:

ADAPTER 1 (FOR PHILIPS)	
BRAND	SINO-AMERICAN
MODEL	SA110C-05S-A
INPUT POWER	100-240Vac, 50-60Hz, 0.3A
OUTPUT POWER	5Vdc, 2A, 10W
POWER LINE	DC 1.5m shielded cable with one core

ADAPTER 2 (FOR ZINWELL)	
BRAND	SINO-AMERICAN
MODEL	SA110C-05S-A
INPUT POWER	100-240Vac, 50-60Hz, 0.3A
OUTPUT POWER	5Vdc, 1.5A, 7.5W
POWER LINE	DC 1.5m shielded USB cable with one core

6. The above EUT information is declared by manufacturer and for more detailed features description, please refer to the manufacturer's specifications or user's manual.



3.2 DESCRIPTION OF TEST MODES

4 channels are provided for WHDI (20MHz):

CHANNEL	FREQUENCY	CHANNEL	FREQUENCY
36	5180MHz	44	5220MHz
40	5200MHz	48	5240MHz

2 channels are provided for WHDI (40MHz):

CHANNEL	FREQUENCY	CHANNEL	FREQUENCY
38	5190MHz	46	5230MHz

3.2.1 CONFIGURATION OF SYSTEM UNDER TEST

TEST MODE A

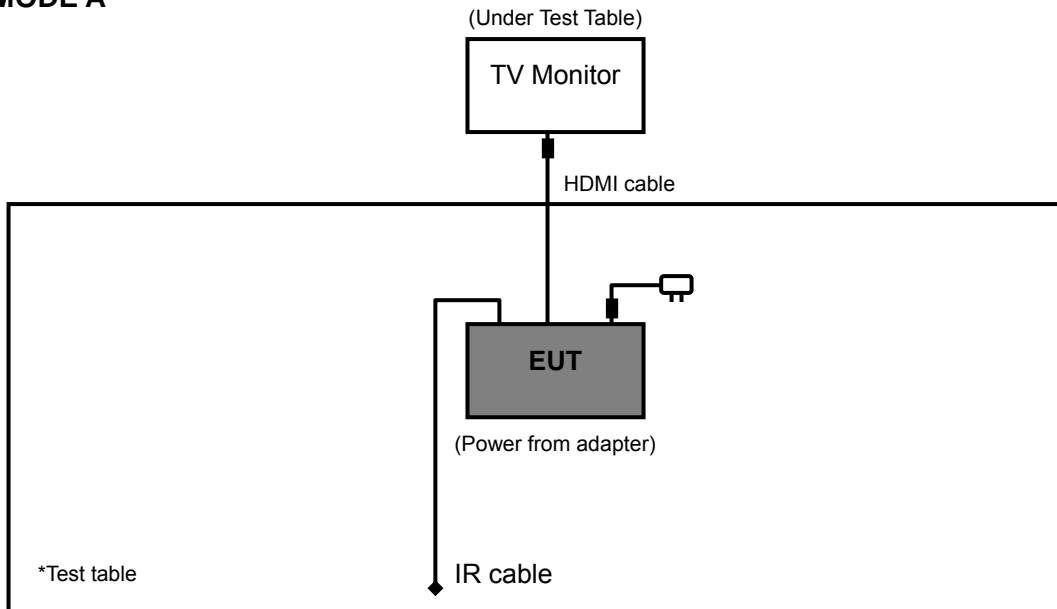

TEST MODE B, C

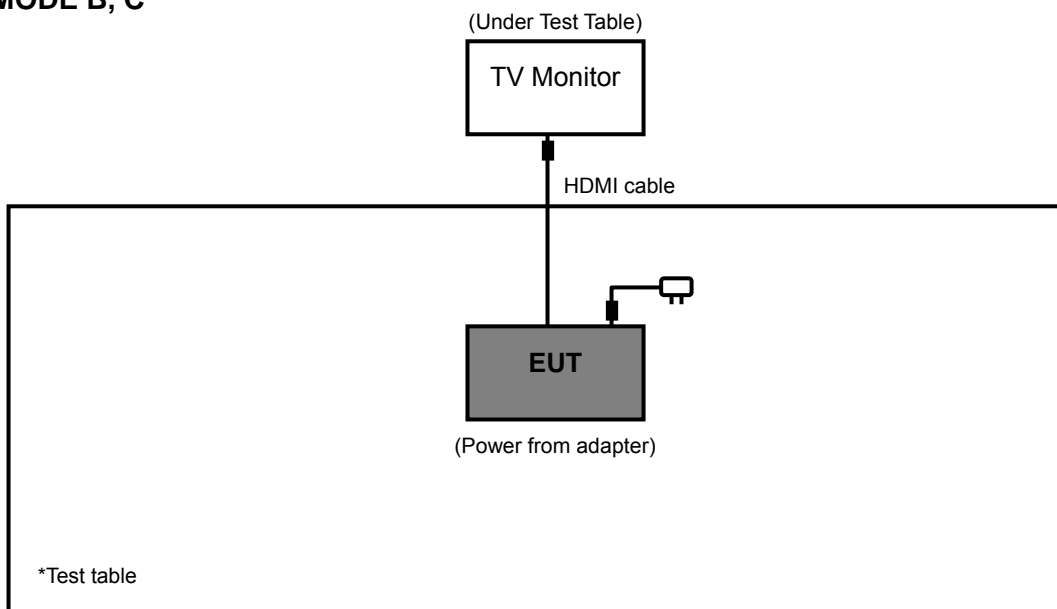

3.2.2 TEST MODE APPLICABILITY AND TESTED CHANNEL DETAIL

EUT CONFIGURE MODE	APPLICABLE TO				DESCRIPTION
	RE \geq 1G	RE<1G	PLC	APCM	
A	√	√	√	√	PHILIPS sample with IR cable
B	-	√	√	-	PHILIPS sample without IR cable
C	-	√	√	-	ZINWELL sample

Where **RE \geq 1G**: Radiated Emission above 1GHz **RE<1G**: Radiated Emission below 1GHz
PLC: Power Line Conducted Emission **APCM**: Antenna Port Conducted Measurement
NOTE: "-" means no effect.

RADIATED EMISSION TEST (ABOVE 1GHz):

- Pre-Scan has been conducted to determine the worst-case mode from all possible combinations between available modulations and antenna ports (if EUT with antenna diversity architecture).
- Following channel(s) was (were) selected for the final test as listed below.

EUT CONFIGURE MODE	MODE	AVAILABLE CHANNEL	TESTED CHANNEL	MODULATION TECHNOLOGY	DATA RATE (kbps)
A	WHDI (20MHz)	36 to 48	36, 40, 48	OFDM	100
A	WHDI (40MHz)	38 to 46	38, 46	OFDM	100

RADIATED EMISSION TEST (BELOW 1GHz):

- Pre-Scan has been conducted to determine the worst-case mode from all possible combinations between available modulations, data rates and antenna ports (if EUT with antenna diversity architecture).
- Following channel(s) was (were) selected for the final test as listed below.

EUT CONFIGURE MODE	MODE	AVAILABLE CHANNEL	TESTED CHANNEL	MODULATION TECHNOLOGY	DATA RATE (kbps)
A, B, C	WHDI (20MHz)	36 to 48	40	OFDM	100

POWER LINE CONDUCTED EMISSION TEST:

- Pre-Scan has been conducted to determine the worst-case mode from all possible combinations between available modulations, data rates and antenna ports (if EUT with antenna diversity architecture).
- Following channel(s) was (were) selected for the final test as listed below.

EUT CONFIGURE MODE	MODE	AVAILABLE CHANNEL	TESTED CHANNEL	MODULATION TECHNOLOGY	DATA RATE (kbps)
A, B, C	WHDI (20MHz)	36 to 48	40	OFDM	100

BANDEDGE MEASUREMENT:

- Pre-Scan has been conducted to determine the worst-case mode from all possible combinations between available modulations, data rates and antenna ports (if EUT with antenna diversity architecture).
- Following channel(s) was (were) selected for the final test as listed below.

EUT CONFIGURE MODE	MODE	AVAILABLE CHANNEL	TESTED CHANNEL	MODULATION TECHNOLOGY	DATA RATE (kbps)
A	WHDI (20MHz)	36 to 48	36, 48	OFDM	100
A	WHDI (40MHz)	38 to 46	38, 46	OFDM	100

ANTENNA PORT CONDUCTED MEASUREMENT:

- This item includes all test value of each mode, but only includes spectrum plot of worst value of each mode.
- Pre-Scan has been conducted to determine the worst-case mode from all possible combinations between available modulations, data rates and antenna ports (if EUT with antenna diversity architecture).
- Following channel(s) was (were) selected for the final test as listed below.

EUT CONFIGURE MODE	MODE	AVAILABLE CHANNEL	TESTED CHANNEL	MODULATION TECHNOLOGY	DATA RATE (kbps)
A	WHDI (20MHz)	36 to 48	36, 40, 48	OFDM	100
A	WHDI (40MHz)	38 to 46	38, 46	OFDM	100

TEST CONDITION:

APPLICABLE TO	ENVIRONMENTAL CONDITIONS	INPUT POWER	TESTED BY
RE≥1G	26deg. C, 68%RH, 1005 hPa,	120Vac, 60Hz	Frank Wang
RE<1G	26deg. C, 68%RH, 1005 hPa	120Vac, 60Hz	Frank Wang
PLC	25deg. C, 68%RH, 1000 hPa	120Vac, 60Hz	Sun Lin
APCM	26deg. C, 68%RH, 1003 hPa	120Vac, 60Hz	Frank Wang

3.3 GENERAL DESCRIPTION OF APPLIED STANDARDS

The EUT is a RF Product. According to the specifications of the manufacturer, it must comply with the requirements of the following standards:

FCC Part 15, Subpart E (15.407)

ANSI C63.4-2003

ANSI C63.10-2009

All test items have been performed and recorded as per the above standards.

NOTE: The EUT is also considered as a kind of computer peripheral, because the connection to computer is necessary for typical use. It has been verified to comply with the requirements of FCC Part 15, Subpart B, Class B (DoC). The test report has been issued separately.

3.4 DESCRIPTION OF SUPPORT UNITS

The EUT has been tested as an independent unit together with other necessary accessories or support units. The following support units or accessories were used to form a representative test configuration during the tests.

NO.	PRODUCT	BRAND	MODEL NO.	SERIAL NO.	FCC ID
1	TV MONITOR	SANYO	SMF32KE5	NA	NA

NO.	SIGNAL CABLE DESCRIPTION OF THE ABOVE SUPPORT UNITS
1	NA

NOTE:

1. All power cords of the above support units are non-shielded (1.8m).
2. Item 1 was under test table during test.

4. TEST TYPES AND RESULTS

4.1 RADIATED EMISSION MEASUREMENT

4.1.1 LIMITS OF RADIATED EMISSION MEASUREMENT

Emissions radiated outside of the specified bands, shall be according to the general radiated limits in 15.209 as following:

FREQUENCIES (MHz)	FIELD STRENGTH (microvolts/meter)	MEASUREMENT DISTANCE (meters)
0.009 ~ 0.490	2400/F(kHz)	300
0.490 ~ 1.705	24000/F(kHz)	30
1.705 ~ 30.0	30	30
30 ~ 88	100	3
88 ~ 216	150	3
216 ~ 960	200	3
Above 960	500	3

NOTE:

1. The lower limit shall apply at the transition frequencies.
2. Emission level (dBuV/m) = 20 log Emission level (uV/m).
3. As shown in 15.35(b), for frequencies above 1000MHz, the field strength limits are based on average detector, however, the peak field strength of any emission shall not exceed the maximum permitted average limits, specified above by more than 20dB under any condition of modulation.

4.1.2 LIMITS OF UNWANTED EMISSION OUT OF THE RESTRICTED BANDS

FREQUENCIES (MHz)	EIRP LIMIT (dBm)	EQUIVALENT FIELD STRENGTH AT 3m (dBµV/m) *NOTE 3
	PK	PK
5150 ~ 5350	-27	68.3
5470 ~ 5725	-27	68.3

NOTE: The following formula is used to convert the equipment isotropic radiated power (eirp) to field strength:

$$E = \frac{1000000\sqrt{30P}}{3} \mu\text{V/m, where P is the eirp (Watts).}$$

4.1.3 TEST INSTRUMENTS

DESCRIPTION & MANUFACTURER	MODEL NO.	SERIAL NO.	DATE OF CALIBRATION	DUE DATE OF CALIBRATION
Test Receiver ROHDE & SCHWARZ	ESCI	100424	Aug. 04, 2010	Aug. 03, 2011
Spectrum Analyzer ROHDE & SCHWARZ	FSP40	100041	Jul. 09, 2010	Jul. 08, 2011
BILOG Antenna SCHWARZBECK	VULB9168	9168-156	Apr. 12, 2011	Apr. 11, 2012
HORN Antenna SCHWARZBECK	BBHA 9120 D	9120D-209	Aug. 02, 2010	Aug. 01, 2011
HORN Antenna SCHWARZBECK	BBHA 9170	BBHA9170243	Dec. 27, 2010	Dec. 26, 2011
Preamplifier Agilent	8449B	3008A01910	Sep. 09, 2010	Sep. 08, 2011
Preamplifier Agilent	8447D	2944A10638	Nov. 03, 2010	Nov. 02, 2011
RF signal cable HUBER+SUHNNER	SUCOFLEX 104	295013/4 283403/4	Sep 03, 2010	Sep 03, 2011
RF signal cable Worken	8D-FB	Cable-HYCH9-01	Aug. 20, 2010	Aug. 19, 2011
Software	ADT_Radiated_ V7.6.15.9.2	NA	NA	NA
Antenna Tower EMCO	2070/2080	512.835.4684	NA	NA
Turn Table EMCO	2087-2.03	NA	NA	NA
Antenna Tower & Turn Table Controller EMCO	2090	NA	NA	NA
26GHz ~ 40GHz Amplifier	EM26400	07026401	Aug. 25, 2010	Aug. 24, 2011

NOTE: 1. The calibration interval of the above test instruments is 12 months and the calibrations are traceable to NML/ROC and NIST/USA.

2. The test was performed in HwaYa Chamber 9.

3. The horn antenna and HP preamplifier (model: 8449B) are used only for the measurement of emission frequency above 1GHz if tested.

4. The FCC Site Registration No. is 460141.

5. The IC Site Registration No. is IC 7450F-4.

4.1.4 TEST PROCEDURES

- a. The EUT was placed on the top of a rotating table 0.8 meters above the ground at a 3 meter semi-anechoic chamber. The table was rotated 360 degrees to determine the position of the highest radiation.
- b. The EUT was set 3 meters away from the interference-receiving antenna, which was mounted on the top of a variable-height antenna tower.
- c. The antenna is a broadband antenna, and its height is varied from one meter to four meters above the ground to determine the maximum value of the field strength. Both horizontal and vertical polarizations of the antenna are set to make the measurement.
- d. For each suspected emission, the EUT was arranged to its worst case and then the antenna was tuned to heights from 1 meter to 4 meters and the rotatable table was turned from 0 degrees to 360 degrees to find the maximum reading.
- e. The test-receiver system was set to Peak Detect Function and Specified Bandwidth with Maximum Hold Mode.
- f. If the emission level of the EUT in peak mode was 10dB lower than the limit specified, then testing could be stopped and the peak values of the EUT would be reported. Otherwise the emissions that did not have 10dB margin would be re-tested one by one using peak, quasi-peak or average method as specified and then reported in a data sheet.

NOTE:

1. The resolution bandwidth and video bandwidth of test receiver/spectrum analyzer is 120kHz for Peak detection (PK) and Quasi-peak detection (QP) at frequency below 1GHz.
2. The resolution bandwidth of test receiver/spectrum analyzer is 1MHz and video bandwidth is 3MHz for Peak detection at frequency above 1GHz.
3. The resolution bandwidth of test receiver/spectrum analyzer is 1MHz and the video bandwidth is 10Hz for Average detection (AV) at frequency above 1GHz.
4. All modes of operation were investigated and the worst-case emissions are reported.

4.1.5 DEVIATION FROM TEST STANDARD

No deviation.

4.1.6 TEST SETUP

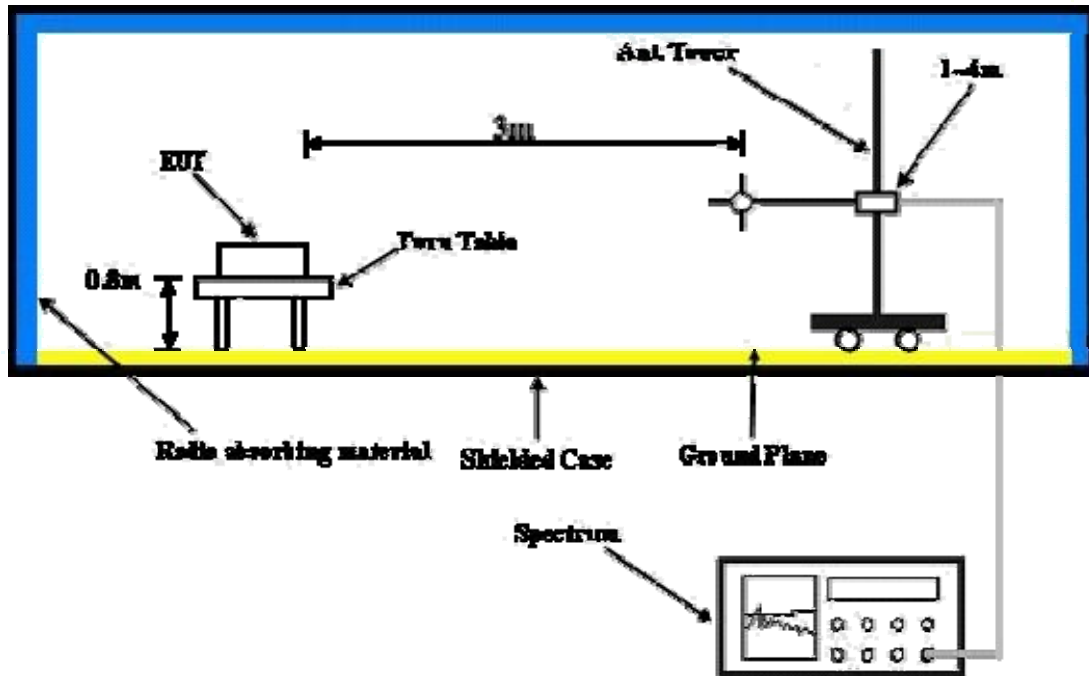

For the actual test configuration, please refer to the attached file (Test Setup Photo).

4.1.7 EUT OPERATING CONDITION

- a. Placed the EUT on the testing table.
- b. The EUT sent messages to the TV monitor, which is acted as a communication partner.

4.1.8 TEST RESULTS

ABOVE 1GHz WORST-CASE DATA: WHDI (20MHz)

EUT TEST CONDITION		MEASUREMENT DETAIL	
CHANNEL	Channel 36	FREQUENCY RANGE	1 ~ 40GHz
INPUT POWER	120Vac, 60 Hz	DETECTOR FUNCTION	Peak (PK) Average (AV)
ENVIRONMENTAL CONDITIONS	26deg. C, 68%RH 1005 hPa	TESTED BY	Frank Wang

ANTENNA POLARITY & TEST DISTANCE: HORIZONTAL AT 3 M								
NO.	FREQ. (MHz)	EMISSION LEVEL (dBuV/m)	LIMIT (dBuV/m)	MARGIN (dB)	ANTENNA HEIGHT (m)	TABLE ANGLE (Degree)	RAW VALUE (dBuV)	CORRECTION FACTOR (dB/m)
1	5150.00	48.8 PK	74.0	-25.2	1.08 H	262	10.30	38.50
2	5150.00	33.2 AV	54.0	-20.8	1.08 H	262	-5.30	38.50
3	*5180.00	110.6 PK			1.00 H	257	72.00	38.60
4	*5180.00	97.3 AV			1.00 H	262	58.70	38.60
5	#10360.00	61.7 PK	68.3	-6.6	1.06 H	65	12.80	48.90
ANTENNA POLARITY & TEST DISTANCE: VERTICAL AT 3 M								
NO.	FREQ. (MHz)	EMISSION LEVEL (dBuV/m)	LIMIT (dBuV/m)	MARGIN (dB)	ANTENNA HEIGHT (m)	TABLE ANGLE (Degree)	RAW VALUE (dBuV)	CORRECTION FACTOR (dB/m)
1	5150.00	48.2 PK	74.0	-25.8	1.25 V	345	9.70	38.50
2	5150.00	33.0 AV	54.0	-21.0	1.25 V	345	-5.50	38.50
3	*5180.00	107.3 PK			1.25 V	345	68.70	38.60
4	*5180.00	95.0 AV			1.25 V	345	56.40	38.60
5	#10360.00	60.6 PK	68.3	-7.7	1.04 V	324	11.70	48.90

- REMARKS:**
1. Emission level (dBuV/m) = Raw Value (dBuV) + Correction Factor (dB/m).
 2. Correction Factor (dB/m) = Antenna Factor (dB/m) + Cable Factor (dB).
 3. The other emission levels were very low against the limit.
 4. Margin value = Emission level – Limit value.
 5. “ * “: Fundamental frequency.
 6. “#“: The radiated frequency is out the restricted band.



A D T

EUT TEST CONDITION		MEASUREMENT DETAIL	
CHANNEL	Channel 40	FREQUENCY RANGE	1 ~ 40GHz
INPUT POWER	120Vac, 60 Hz	DETECTOR FUNCTION	Peak (PK) Average (AV)
ENVIRONMENTAL CONDITIONS	26deg. C, 68%RH 1005 hPa	TESTED BY	Frank Wang

ANTENNA POLARITY & TEST DISTANCE: HORIZONTAL AT 3 M								
NO.	FREQ. (MHz)	EMISSION LEVEL (dBuV/m)	LIMIT (dBuV/m)	MARGIN (dB)	ANTENNA HEIGHT (m)	TABLE ANGLE (Degree)	RAW VALUE (dBuV)	CORRECTION FACTOR (dB/m)
1	*5200.00	110.4 PK			1.04 H	218	71.80	38.60
2	*5200.00	96.8 AV			1.04 H	218	58.20	38.60
3	#10400.00	59.9 PK	68.3	-8.4	1.10 H	68	10.90	49.00
4	15600.00	53.7 PK	74.0	-20.3	1.00 H	240	4.50	49.20
5	15600.00	40.0 AV	54.0	-14.0	1.00 H	240	-9.20	49.20
ANTENNA POLARITY & TEST DISTANCE: VERTICAL AT 3 M								
NO.	FREQ. (MHz)	EMISSION LEVEL (dBuV/m)	LIMIT (dBuV/m)	MARGIN (dB)	ANTENNA HEIGHT (m)	TABLE ANGLE (Degree)	RAW VALUE (dBuV)	CORRECTION FACTOR (dB/m)
1	*5200.00	107.0 PK			1.04 V	335	68.40	38.60
2	*5200.00	94.6 AV			1.04 V	335	56.00	38.60
3	#10400.00	57.1 PK	68.3	-11.2	1.00 V	173	8.10	49.00
4	15600.00	52.6 PK	74.0	-21.4	1.00 V	312	3.40	49.20
5	15600.00	39.5 AV	54.0	-14.5	1.00 V	312	-9.70	49.20

- REMARKS:**
1. Emission level (dBuV/m) = Raw Value (dBuV) + Correction Factor (dB/m).
 2. Correction Factor (dB/m) = Antenna Factor (dB/m) + Cable Factor (dB).
 3. The other emission levels were very low against the limit.
 4. Margin value = Emission level – Limit value.
 5. “ * “: Fundamental frequency.
 6. “#”: The radiated frequency is out the restricted band.



A D T

EUT TEST CONDITION		MEASUREMENT DETAIL	
CHANNEL	Channel 48	FREQUENCY RANGE	1 ~ 40GHz
INPUT POWER	120Vac, 60 Hz	DETECTOR FUNCTION	Peak (PK) Average (AV)
ENVIRONMENTAL CONDITIONS	26deg. C, 68%RH 1005 hPa	TESTED BY	Frank Wang

ANTENNA POLARITY & TEST DISTANCE: HORIZONTAL AT 3 M								
NO.	FREQ. (MHz)	EMISSION LEVEL (dBuV/m)	LIMIT (dBuV/m)	MARGIN (dB)	ANTENNA HEIGHT (m)	TABLE ANGLE (Degree)	RAW VALUE (dBuV)	CORRECTION FACTOR (dB/m)
1	*5240.00	110.6 PK			1.00 H	225	72.00	38.60
2	*5240.00	96.8 AV			1.00 H	225	58.20	38.60
3	5350.00	44.7 PK	74.0	-29.3	1.10 H	224	6.00	38.70
4	5350.00	32.1 AV	54.0	-21.9	1.10 H	224	-6.60	38.70
5	#10480.00	58.8 PK	68.3	-9.5	1.00 H	67	9.50	49.30
ANTENNA POLARITY & TEST DISTANCE: VERTICAL AT 3 M								
NO.	FREQ. (MHz)	EMISSION LEVEL (dBuV/m)	LIMIT (dBuV/m)	MARGIN (dB)	ANTENNA HEIGHT (m)	TABLE ANGLE (Degree)	RAW VALUE (dBuV)	CORRECTION FACTOR (dB/m)
1	*5240.00	107.6 PK			1.03 V	342	69.00	38.60
2	*5240.00	95.0 AV			1.03 V	342	56.40	38.60
3	5350.00	43.4 PK	74.0	-30.6	1.03 V	342	4.70	38.70
4	5350.00	30.9 AV	54.0	-23.1	1.03 V	342	-7.80	38.70
5	#10480.00	56.6 PK	68.3	-11.7	1.00 V	171	7.30	49.30

- REMARKS:**
1. Emission level (dBuV/m) = Raw Value (dBuV) + Correction Factor (dB/m).
 2. Correction Factor (dB/m) = Antenna Factor (dB/m) + Cable Factor (dB).
 3. The other emission levels were very low against the limit.
 4. Margin value = Emission level – Limit value.
 5. “ * “: Fundamental frequency.
 6. “#”: The radiated frequency is out the restricted band.

WHDI (40MHz)

EUT TEST CONDITION		MEASUREMENT DETAIL	
CHANNEL	Channel 38	FREQUENCY RANGE	1 ~ 40GHz
INPUT POWER	120Vac, 60 Hz	DETECTOR FUNCTION	Peak (PK) Average (AV)
ENVIRONMENTAL CONDITIONS	25deg. C, 66%RH 1005 hPa	TESTED BY	Frank Wang

ANTENNA POLARITY & TEST DISTANCE: HORIZONTAL AT 3 M								
NO.	FREQ. (MHz)	EMISSION LEVEL (dBuV/m)	LIMIT (dBuV/m)	MARGIN (dB)	ANTENNA HEIGHT (m)	TABLE ANGLE (Degree)	RAW VALUE (dBuV)	CORRECTION FACTOR (dB/m)
1	5150.00	59.0 PK	74.0	-15.0	1.27 H	92	20.50	38.50
2	5150.00	40.8 AV	54.0	-13.2	1.27 H	92	2.30	38.50
3	*5190.00	106.4 PK			1.32 H	92	67.80	38.60
4	*5190.00	93.8 AV			1.32 H	92	55.20	38.60
5	#10380.00	61.8 PK	68.3	-6.5	1.40 H	242	12.80	49.00
ANTENNA POLARITY & TEST DISTANCE: VERTICAL AT 3 M								
NO.	FREQ. (MHz)	EMISSION LEVEL (dBuV/m)	LIMIT (dBuV/m)	MARGIN (dB)	ANTENNA HEIGHT (m)	TABLE ANGLE (Degree)	RAW VALUE (dBuV)	CORRECTION FACTOR (dB/m)
1	5150.00	54.9 PK	74.0	-19.1	1.09 V	144	16.40	38.50
2	5150.00	36.8 AV	54.0	-17.2	1.09 V	144	-1.70	38.50
3	*5190.00	103.9 PK			1.09 V	144	65.30	38.60
4	*5190.00	91.5 AV			1.09 V	144	52.90	38.60
5	#10380.00	60.9 PK	68.3	-7.4	1.30 V	75	11.90	49.00

- REMARKS:**
1. Emission level (dBuV/m) = Raw Value (dBuV) + Correction Factor (dB/m).
 2. Correction Factor (dB/m) = Antenna Factor (dB/m) + Cable Factor (dB).
 3. The other emission levels were very low against the limit.
 4. Margin value = Emission level – Limit value.
 5. “ * “: Fundamental frequency.
 6. “#”:The radiated frequency is out the restricted band.



A D T

EUT TEST CONDITION		MEASUREMENT DETAIL	
CHANNEL	Channel 46	FREQUENCY RANGE	1 ~ 40GHz
INPUT POWER	120Vac, 60 Hz	DETECTOR FUNCTION	Peak (PK) Average (AV)
ENVIRONMENTAL CONDITIONS	25deg. C, 66%RH 1005 hPa	TESTED BY	Frank Wang

ANTENNA POLARITY & TEST DISTANCE: HORIZONTAL AT 3 M								
NO.	FREQ. (MHz)	EMISSION LEVEL (dBuV/m)	LIMIT (dBuV/m)	MARGIN (dB)	ANTENNA HEIGHT (m)	TABLE ANGLE (Degree)	RAW VALUE (dBuV)	CORRECTION FACTOR (dB/m)
1	*5230.00	106.1 PK			1.21 H	100	67.50	38.60
2	*5230.00	93.5 AV			1.21 H	100	54.90	38.60
3	5350.00	44.9 PK	74.0	-29.1	1.21 H	100	6.20	38.70
4	5350.00	32.6 AV	54.0	-21.4	1.21 H	100	-6.10	38.70
5	#10460.00	61.1 PK	68.3	-7.2	1.29 H	239	11.90	49.20
ANTENNA POLARITY & TEST DISTANCE: VERTICAL AT 3 M								
NO.	FREQ. (MHz)	EMISSION LEVEL (dBuV/m)	LIMIT (dBuV/m)	MARGIN (dB)	ANTENNA HEIGHT (m)	TABLE ANGLE (Degree)	RAW VALUE (dBuV)	CORRECTION FACTOR (dB/m)
1	*5230.00	103.6 PK			1.10 V	142	65.00	38.60
2	*5230.00	91.1 AV			1.10 V	142	52.50	38.60
3	5350.00	43.3 PK	74.0	-30.7	1.10 V	142	4.60	38.70
4	5350.00	31.4 AV	54.0	-22.6	1.10 V	142	-7.30	38.70
5	#10460.00	60.8 PK	68.3	-7.5	1.28 V	61	11.60	49.20

- REMARKS:**
1. Emission level (dBuV/m) = Raw Value (dBuV) + Correction Factor (dB/m).
 2. Correction Factor (dB/m) = Antenna Factor (dB/m) + Cable Factor (dB).
 3. The other emission levels were very low against the limit.
 4. Margin value = Emission level – Limit value.
 5. “ * “: Fundamental frequency.
 6. “#”: The radiated frequency is out the restricted band.



A D T

BELOW 1GHz WORST-CASE DATA: WHDI (20MHz)

EUT TEST CONDITION		MEASUREMENT DETAIL	
CHANNEL	Channel 40	FREQUENCY RANGE	Below 1000MHz
INPUT POWER	120Vac, 60 Hz	DETECTOR FUNCTION	Quasi-Peak
ENVIRONMENTAL CONDITIONS	26deg. C, 68%RH 1005 hPa	TESTED BY	Frank Wang
TEST MODE	A		

ANTENNA POLARITY & TEST DISTANCE: HORIZONTAL AT 3 M								
NO.	FREQ. (MHz)	EMISSION LEVEL (dBuV/m)	LIMIT (dBuV/m)	MARGIN (dB)	ANTENNA HEIGHT (m)	TABLE ANGLE (Degree)	RAW VALUE (dBuV)	CORRECTION FACTOR (dB/m)
1	142.67	41.2 QP	43.5	-2.3	2.00 H	73	26.30	14.90
2	339.04	36.1 QP	46.0	-9.9	1.00 H	229	19.50	16.60
3	420.70	36.2 QP	46.0	-9.8	1.00 H	46	17.00	19.20
4	459.59	38.7 QP	46.0	-7.3	2.00 H	244	18.40	20.30
5	620.96	39.7 QP	46.0	-6.3	1.50 H	334	15.70	24.00
6	904.83	39.7 QP	46.0	-6.3	1.00 H	64	11.00	28.70
ANTENNA POLARITY & TEST DISTANCE: VERTICAL AT 3 M								
NO.	FREQ. (MHz)	EMISSION LEVEL (dBuV/m)	LIMIT (dBuV/m)	MARGIN (dB)	ANTENNA HEIGHT (m)	TABLE ANGLE (Degree)	RAW VALUE (dBuV)	CORRECTION FACTOR (dB/m)
1	142.67	40.4 QP	43.5	-3.1	1.00 V	61	25.50	14.90
2	399.31	41.0 QP	46.0	-5.0	2.00 V	10	22.40	18.60
3	459.59	37.9 QP	46.0	-8.1	1.00 V	88	17.60	20.30
4	500.42	39.0 QP	46.0	-7.0	1.00 V	97	17.60	21.40
5	620.96	31.9 QP	46.0	-14.1	1.50 V	310	7.90	24.00
6	881.50	33.1 QP	46.0	-12.9	1.00 V	136	4.70	28.40

- REMARKS:**
1. Emission level (dBuV/m) = Raw Value (dBuV) + Correction Factor (dB/m).
 2. Correction Factor (dB/m) = Antenna Factor (dB/m) + Cable Factor (dB).
 3. The other emission levels were very low against the limit.
 4. Margin value = Emission level – Limit value.



A D T

EUT TEST CONDITION		MEASUREMENT DETAIL	
CHANNEL	Channel 40	FREQUENCY RANGE	Below 1000MHz
INPUT POWER	120Vac, 60 Hz	DETECTOR FUNCTION	Quasi-Peak
ENVIRONMENTAL CONDITIONS	25deg. C, 63%RH 1005 hPa	TESTED BY	Frank Wang
TEST MODE	B		

ANTENNA POLARITY & TEST DISTANCE: HORIZONTAL AT 3 M								
NO.	FREQ. (MHz)	EMISSION LEVEL (dBuV/m)	LIMIT (dBuV/m)	MARGIN (dB)	ANTENNA HEIGHT (m)	TABLE ANGLE (Degree)	RAW VALUE (dBuV)	CORRECTION FACTOR (dB/m)
1	142.67	40.3 QP	43.5	-3.2	2.00 H	277	25.40	14.90
2	379.87	39.8 QP	46.0	-6.2	1.00 H	280	21.80	18.00
3	420.70	39.8 QP	46.0	-6.2	2.00 H	124	20.60	19.20
4	500.42	39.8 QP	46.0	-6.2	1.50 H	175	18.40	21.40
5	640.41	34.7 QP	46.0	-11.3	1.25 H	19	10.40	24.30
6	881.50	31.6 QP	46.0	-14.4	1.75 H	178	3.20	28.40

ANTENNA POLARITY & TEST DISTANCE: VERTICAL AT 3 M								
NO.	FREQ. (MHz)	EMISSION LEVEL (dBuV/m)	LIMIT (dBuV/m)	MARGIN (dB)	ANTENNA HEIGHT (m)	TABLE ANGLE (Degree)	RAW VALUE (dBuV)	CORRECTION FACTOR (dB/m)
1	31.84	27.7 QP	40.0	-12.3	1.00 V	10	14.80	12.90
2	142.67	32.0 QP	43.5	-11.5	1.00 V	181	17.10	14.90
3	379.87	35.8 QP	46.0	-10.2	1.00 V	307	17.80	18.00
4	500.42	36.8 QP	46.0	-9.2	1.00 V	148	15.40	21.40
5	580.13	32.3 QP	46.0	-13.7	1.50 V	349	9.10	23.20
6	881.50	31.6 QP	46.0	-14.4	1.25 V	217	3.20	28.40

- REMARKS:**
1. Emission level (dBuV/m) = Raw Value (dBuV) + Correction Factor (dB/m).
 2. Correction Factor (dB/m) = Antenna Factor (dB/m) + Cable Factor (dB).
 3. The other emission levels were very low against the limit.
 4. Margin value = Emission level – Limit value.



A D T

EUT TEST CONDITION		MEASUREMENT DETAIL	
CHANNEL	Channel 40	FREQUENCY RANGE	Below 1000MHz
INPUT POWER	120Vac, 60 Hz	DETECTOR FUNCTION	Quasi-Peak
ENVIRONMENTAL CONDITIONS	26deg. C, 68%RH 1005 hPa	TESTED BY	Frank Wang
TEST MODE	C		

ANTENNA POLARITY & TEST DISTANCE: HORIZONTAL AT 3 M								
NO.	FREQ. (MHz)	EMISSION LEVEL (dBuV/m)	LIMIT (dBuV/m)	MARGIN (dB)	ANTENNA HEIGHT (m)	TABLE ANGLE (Degree)	RAW VALUE (dBuV)	CORRECTION FACTOR (dB/m)
1	142.67	41.6 QP	43.5	-1.9	2.00 H	325	26.70	14.90
2	339.04	36.7 QP	46.0	-9.3	1.00 H	253	20.10	16.60
3	479.03	41.5 QP	46.0	-4.5	1.50 H	304	20.70	20.80
4	640.41	38.4 QP	46.0	-7.6	1.00 H	313	14.10	24.30
5	840.67	40.9 QP	46.0	-5.1	1.50 H	304	12.90	28.00
6	881.50	43.9 QP	46.0	-2.1	1.50 H	298	15.50	28.40

ANTENNA POLARITY & TEST DISTANCE: VERTICAL AT 3 M								
NO.	FREQ. (MHz)	EMISSION LEVEL (dBuV/m)	LIMIT (dBuV/m)	MARGIN (dB)	ANTENNA HEIGHT (m)	TABLE ANGLE (Degree)	RAW VALUE (dBuV)	CORRECTION FACTOR (dB/m)
1	142.67	41.1 QP	43.5	-2.4	1.50 V	337	26.20	14.90
2	420.70	39.4 QP	46.0	-6.6	1.00 V	148	20.20	19.20
3	479.03	40.7 QP	46.0	-5.3	1.00 V	10	19.90	20.80
4	599.58	32.8 QP	46.0	-13.2	1.50 V	280	9.10	23.70
5	840.67	36.8 QP	46.0	-9.2	1.00 V	256	8.80	28.00
6	881.50	35.9 QP	46.0	-10.1	1.00 V	244	7.50	28.40

- REMARKS:**
1. Emission level (dBuV/m) = Raw Value (dBuV) + Correction Factor (dB/m).
 2. Correction Factor (dB/m) = Antenna Factor (dB/m) + Cable Factor (dB).
 3. The other emission levels were very low against the limit.
 4. Margin value = Emission level – Limit value.

4.2 CONDUCTED EMISSION MEASUREMENT

4.2.1 LIMITS OF CONDUCTED EMISSION MEASUREMENT

FREQUENCY OF EMISSION (MHz)	CONDUCTED LIMIT (dB μ V)	
	Quasi-peak	Average
0.15 ~ 0.5	66 to 56	56 to 46
0.5 ~ 5	56	46
5 ~ 30	60	50

- NOTE:** 1. The lower limit shall apply at the transition frequencies.
 2. The limit decreases in line with the logarithm of the frequency in the range of 0.15 to 0.50MHz.
 3. All emanations from a class A/B digital device or system, including any network of conductors and apparatus connected thereto, shall not exceed the level of field strengths specified above.

4.2.2 TEST INSTRUMENTS

DESCRIPTION & MANUFACTURER	MODEL NO.	SERIAL NO.	DATE OF CALIBRATION	DUE DATE OF CALIBRATION
Test Receiver ROHDE & SCHWARZ	ESCS30	100289	Nov. 23, 2010	Nov. 22, 2011
RF signal cable Woken	5D-FB	Cable-HYCO2-01	Dec. 30, 2010	Dec. 29, 2011
LISN ROHDE & SCHWARZ	ESH2-Z5	100100	Jan. 06, 2011	Jan. 05, 2012
LISN ROHDE & SCHWARZ	ESH3-Z5	100311	Jul. 08, 2010	Jul. 07, 2011
V-LISN SCHWARZBECK	NNBL 8226-2	8226-142	Jul. 12, 2010	Jul. 11, 2011
LISN ROHDE & SCHWARZ	ENV216	100072	Jun. 10, 2011	Jun. 09, 2012
Software ADT	ADT_Cond_ V7.3.7	NA	NA	NA

- NOTE:** 1. The calibration interval of the above test instruments is 12 months and the calibrations are traceable to NML/ROC and NIST/USA.
 2. The test was performed in HwaYa Shielded Room 2.
 3. The VCCI Site Registration No. is C-2047.

4.2.3 TEST PROCEDURES

- a. The EUT was placed 0.4 meters from the conducting wall of the shielded room with EUT being connected to the power mains through a line impedance stabilization network (LISN). Other support units were connected to the power mains through another LISN. The two LISNs provide 50 ohm/ 50uH of coupling impedance for the measuring instrument.
- b. Both lines of the power mains connected to the EUT were checked for maximum conducted interference.
- c. The frequency range from 150kHz to 30MHz was searched. Emission levels under (Limit - 20dB) was not recorded.

NOTE: All modes of operation were investigated and the worst-case emissions are reported.

4.2.4 DEVIATION FROM TEST STANDARD

No deviation.

4.2.5 TEST SETUP

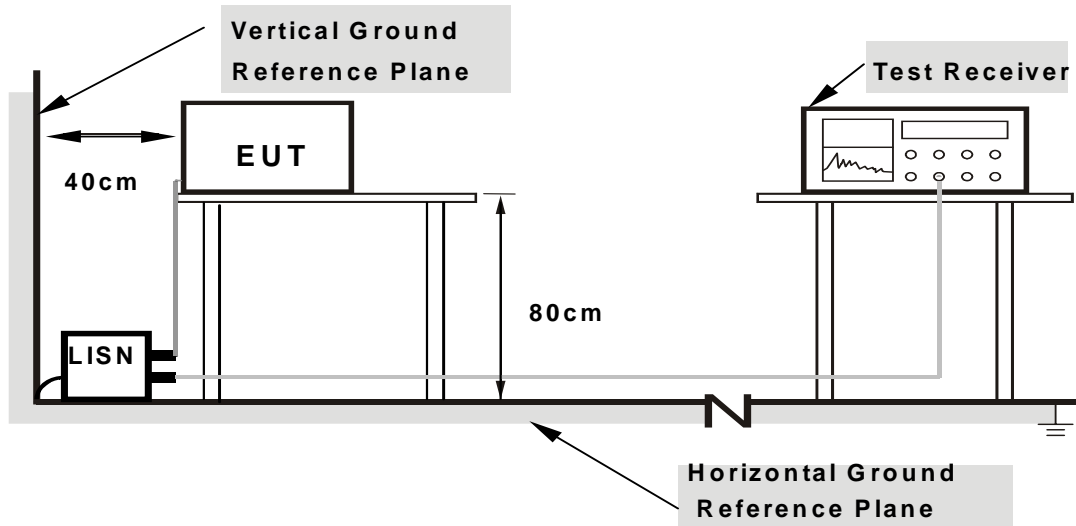

- Note:**
1. Support units were connected to second LISN.
 2. Both of LISNs (AMN) are 80 cm from EUT and at least 80 from other units and other metal planes

For the actual test configuration, please refer to the attached file (Test Setup Photo).

4.2.6 EUT OPERATING CONDITIONS

Same as 4.1.6.

4.2.7 TEST RESULTS

CONDUCTED WORST-CASE DATA :

6dB BANDWIDTH	9kHz	PHASE	Line 1
TEST MODE	A		

No	Freq. [MHz]	Corr. Factor (dB)	Reading Value		Emission Level		Limit		Margin	
			[dB (uV)]		[dB (uV)]		[dB (uV)]		(dB)	
			Q.P.	AV.	Q.P.	AV.	Q.P.	AV.	Q.P.	AV.
1	0.193	0.15	38.77	-	38.92	-	63.91	53.91	-24.99	-
2	0.259	0.16	37.24	-	37.40	-	61.45	51.45	-24.06	-
3	0.451	0.17	36.77	-	36.94	-	56.86	46.86	-19.92	-
4	0.545	0.17	36.90	-	37.07	-	56.00	46.00	-18.93	-
5	8.902	0.52	38.68	-	39.20	-	60.00	50.00	-20.80	-
6	16.199	0.93	44.46	-	45.39	-	60.00	50.00	-14.61	-

- REMARKS:**
1. Q.P. and AV. are abbreviations of quasi-peak and average individually.
 2. "-": The Quasi-peak reading value also meets average limit and measurement with the average detector is unnecessary.
 3. The emission levels of other frequencies were very low against the limit.
 4. Margin value = Emission level - Limit value
 5. Correction factor = Insertion loss + Cable loss
 6. Emission Level = Correction Factor + Reading Value.

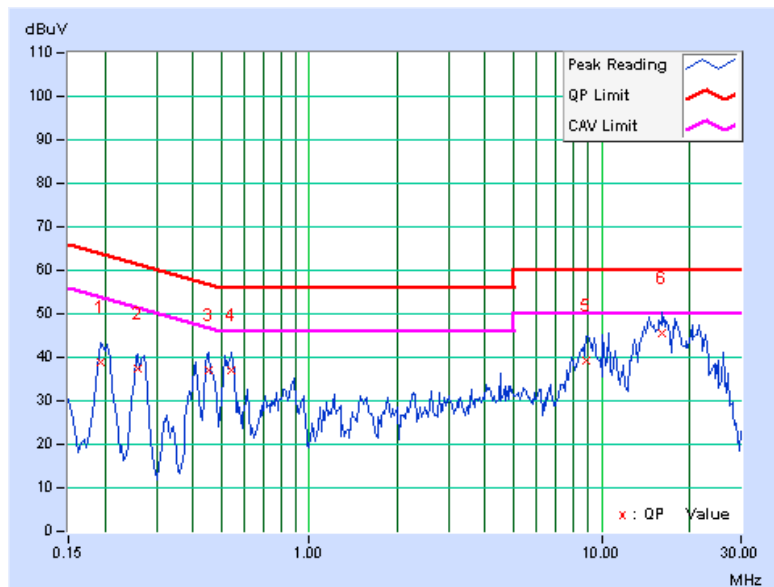



A D T

6dB BANDWIDTH	9kHz	PHASE	Line 2
TEST MODE	A		

No	Freq. [MHz]	Corr. Factor (dB)	Reading Value [dB (uV)]		Emission Level [dB (uV)]		Limit [dB (uV)]		Margin (dB)	
			Q.P.	AV.	Q.P.	AV.	Q.P.	AV.	Q.P.	AV.
1	0.201	0.17	41.10	-	41.27	-	63.58	53.58	-22.31	-
2	0.271	0.18	36.78	-	36.96	-	61.08	51.08	-24.13	-
3	0.447	0.19	36.97	-	37.16	-	56.93	46.93	-19.77	-
4	0.880	0.21	27.70	-	27.91	-	56.00	46.00	-28.09	-
5	15.000	0.73	47.69	-	48.42	-	60.00	50.00	-11.58	-
6	21.805	0.96	42.88	-	43.84	-	60.00	50.00	-16.16	-

- REMARKS:**
1. Q.P. and AV. are abbreviations of quasi-peak and average individually.
 2. "-": The Quasi-peak reading value also meets average limit and measurement with the average detector is unnecessary.
 3. The emission levels of other frequencies were very low against the limit.
 4. Margin value = Emission level - Limit value
 5. Correction factor = Insertion loss + Cable loss
 6. Emission Level = Correction Factor + Reading Value.

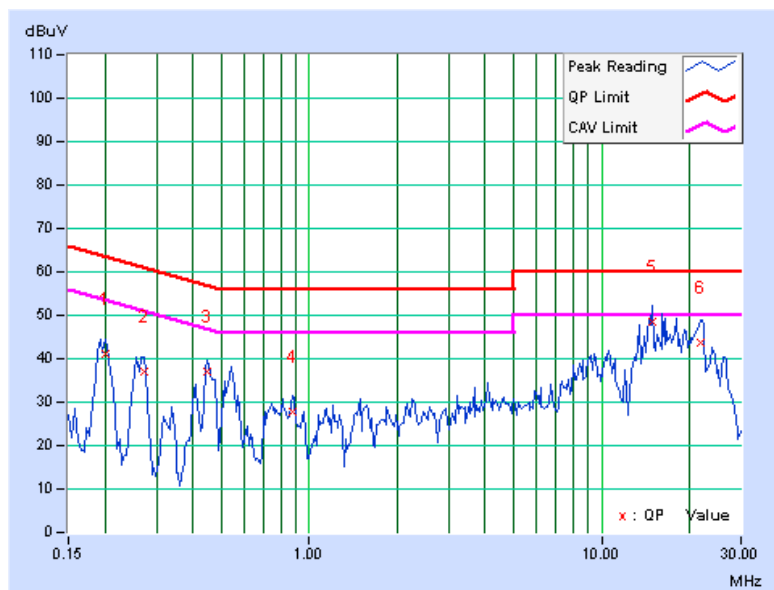



A D T

6dB BANDWIDTH	9kHz	PHASE	Line 1
TEST MODE	B		

No	Freq. [MHz]	Corr. Factor (dB)	Reading Value [dB (uV)]		Emission Level [dB (uV)]		Limit [dB (uV)]		Margin (dB)	
			Q.P.	AV.	Q.P.	AV.	Q.P.	AV.	Q.P.	AV.
1	0.189	0.15	41.23	-	41.38	-	64.08	54.08	-22.70	-
2	0.259	0.16	40.61	-	40.77	-	61.45	51.45	-20.69	-
3	0.459	0.17	38.70	-	38.87	-	56.72	46.72	-17.85	-
4	9.699	0.55	39.51	-	40.06	-	60.00	50.00	-19.94	-
5	15.004	0.87	47.53	-	48.40	-	60.00	50.00	-11.60	-
6	21.703	1.17	45.19	-	46.36	-	60.00	50.00	-13.64	-

- REMARKS:**
1. Q.P. and AV. are abbreviations of quasi-peak and average individually.
 2. "-": The Quasi-peak reading value also meets average limit and measurement with the average detector is unnecessary.
 3. The emission levels of other frequencies were very low against the limit.
 4. Margin value = Emission level - Limit value
 5. Correction factor = Insertion loss + Cable loss
 6. Emission Level = Correction Factor + Reading Value.

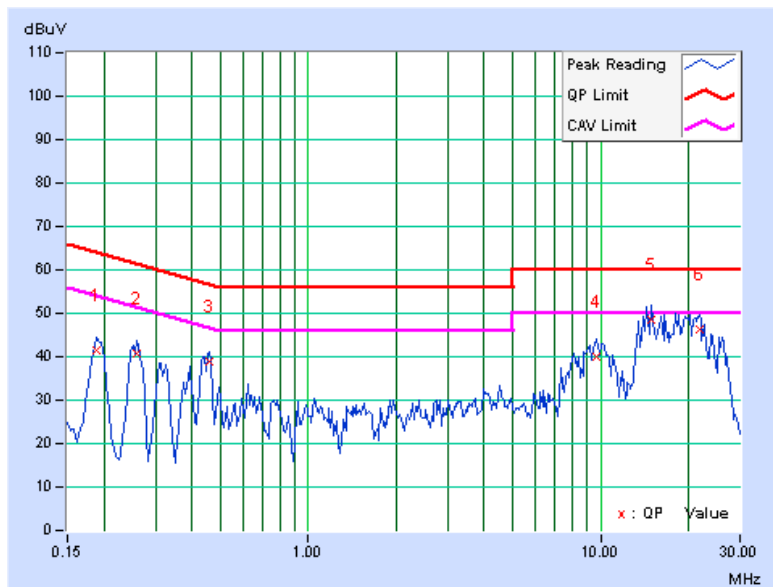



6dB BANDWIDTH	9kHz	PHASE	Line 2
TEST MODE	B		

No	Freq. [MHz]	Corr. Factor (dB)	Reading Value [dB (uV)]		Emission Level [dB (uV)]		Limit [dB (uV)]		Margin (dB)	
			Q.P.	AV.	Q.P.	AV.	Q.P.	AV.	Q.P.	AV.
1	0.189	0.17	42.36	-	42.53	-	64.08	54.08	-21.55	-
2	0.252	0.18	38.63	-	38.81	-	61.71	51.71	-22.90	-
3	0.392	0.19	34.46	-	34.65	-	58.02	48.02	-23.37	-
4	9.195	0.48	38.20	-	38.68	-	60.00	50.00	-21.32	-
5	15.000	0.73	47.87	-	48.60	-	60.00	50.00	-11.40	-
6	21.004	0.94	46.80	-	47.74	-	60.00	50.00	-12.26	-

- REMARKS:**
1. Q.P. and AV. are abbreviations of quasi-peak and average individually.
 2. "-": The Quasi-peak reading value also meets average limit and measurement with the average detector is unnecessary.
 3. The emission levels of other frequencies were very low against the limit.
 4. Margin value = Emission level - Limit value
 5. Correction factor = Insertion loss + Cable loss
 6. Emission Level = Correction Factor + Reading Value.

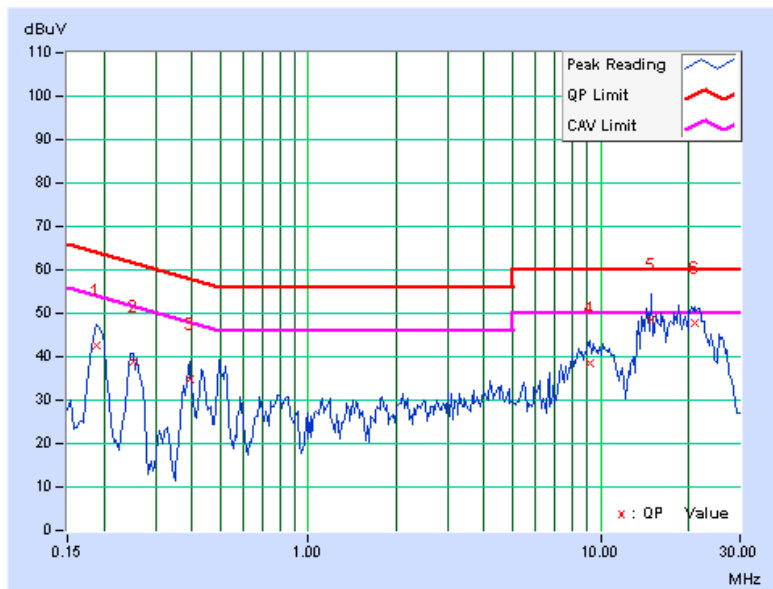



A D T

6dB BANDWIDTH	9kHz	PHASE	Line 1
TEST MODE	C		

No	Freq. [MHz]	Corr. Factor (dB)	Reading Value [dB (uV)]		Emission Level [dB (uV)]		Limit [dB (uV)]		Margin (dB)	
			Q.P.	AV.	Q.P.	AV.	Q.P.	AV.	Q.P.	AV.
1	0.193	0.15	42.79	-	42.94	-	63.91	53.91	-20.97	-
2	0.271	0.16	38.32	-	38.48	-	61.08	51.08	-22.61	-
3	0.451	0.17	34.82	-	34.99	-	56.86	46.86	-21.87	-
4	9.207	0.53	38.95	-	39.48	-	60.00	50.00	-20.52	-
5	15.000	0.87	46.23	-	47.10	-	60.00	50.00	-12.90	-
6	21.207	1.16	46.70	-	47.86	-	60.00	50.00	-12.14	-

- REMARKS:**
1. Q.P. and AV. are abbreviations of quasi-peak and average individually.
 2. "-": The Quasi-peak reading value also meets average limit and measurement with the average detector is unnecessary.
 3. The emission levels of other frequencies were very low against the limit.
 4. Margin value = Emission level - Limit value
 5. Correction factor = Insertion loss + Cable loss
 6. Emission Level = Correction Factor + Reading Value.

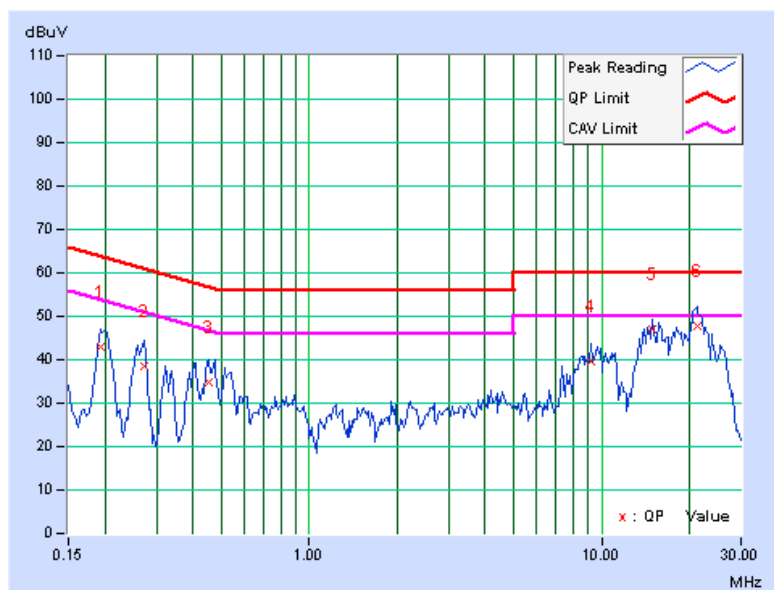



A D T

6dB BANDWIDTH	9kHz	PHASE	Line 2
TEST MODE	C		

No	Freq. [MHz]	Corr. Factor (dB)	Reading Value [dB (uV)]		Emission Level [dB (uV)]		Limit [dB (uV)]		Margin (dB)	
			Q.P.	AV.	Q.P.	AV.	Q.P.	AV.	Q.P.	AV.
1	0.193	0.17	43.25	-	43.42	-	63.91	53.91	-20.49	-
2	0.271	0.18	37.92	-	38.10	-	61.08	51.08	-22.99	-
3	0.451	0.19	36.30	-	36.49	-	56.86	46.86	-20.37	-
4	9.703	0.49	38.69	-	39.18	-	60.00	50.00	-20.82	-
5	15.000	0.73	48.54	-	49.27	-	60.00	50.00	-10.73	-
6	21.008	0.94	46.08	-	47.02	-	60.00	50.00	-12.98	-

- REMARKS:**
1. Q.P. and AV. are abbreviations of quasi-peak and average individually.
 2. "-": The Quasi-peak reading value also meets average limit and measurement with the average detector is unnecessary.
 3. The emission levels of other frequencies were very low against the limit.
 4. Margin value = Emission level - Limit value
 5. Correction factor = Insertion loss + Cable loss
 6. Emission Level = Correction Factor + Reading Value.

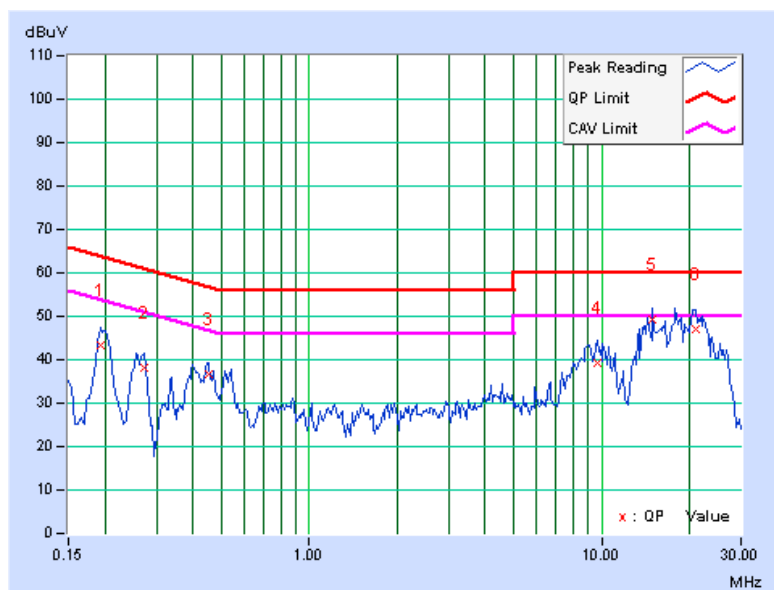

4.3 MAXIMUM CONDUCTED OUTPUT POWER MEASUREMENT

4.3.1 LIMITS OF MAXIMUM CONDUCTED OUTPUT POWER MEASUREMENT

FREQUENCY BAND	LIMIT
5.15 ~ 5.25GHz	The lesser of 50mW (17dBm) or 4dBm + 10logB

NOTE: Where B is the 26dB emission bandwidth in MHz.

4.3.2 TEST INSTRUMENTS

FOR POWER OUTPUT MEASUREMENT

DESCRIPTION & MANUFACTURER	MODEL NO.	SERIAL NO.	DATE OF CALIBRATION	DUE DATE OF CALIBRATION
High Speed Peak Power Meter	ML2495A	0824011	Aug. 02, 2010	Aug. 01, 2011
Power Sensor	MA2411B	0738171	Aug. 02, 2010	Aug. 01, 2011

NOTE: 1. The calibration interval of the above test instruments is 12 months and the calibrations are traceable to NML/ROC and NIST/USA.
 2. Measurement Bandwidth of ML2495A is 65MHz greater than 26dB bandwidth of emission.

FOR 26dB OCCUPIED BANDWIDTH

DESCRIPTION & MANUFACTURER	MODEL NO.	SERIAL NO.	DATE OF CALIBRATION	DUE DATE OF CALIBRATION
SPECTRUM ANALYZER R&S	FSP40	100040	Jul. 17, 2010	Jul. 16, 2011

NOTE: The calibration interval of the above test instruments is 12 months and the calibrations are traceable to NML/ROC and NIST/USA.

4.3.3 TEST PROCEDURE

FOR POWER OUTPUT MEASUREMENT

A power sensor was used on the output port of the EUT. A power meter was used to read the response of the power sensor. Record the power level.

FOR 26dB OCCUPIED BANDWIDTH

The transmitter output was connected to the spectrum analyzer through an attenuator. The bandwidth of the fundamental frequency was measured by spectrum analyzer with 300kHz RBW and 1MHz VBW. The 26dB bandwidth is defined as the total spectrum the power of which is higher than peak power minus 26dB.

4.3.4 DEVIATION FROM TEST STANDARD

No deviation.

4.3.5 TEST SETUP

FOR POWER OUTPUT MEASUREMENT

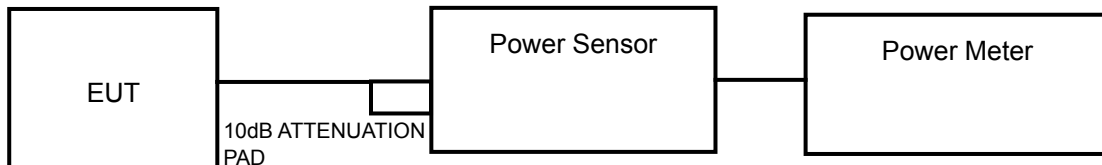

FOR 26dB OCCUPIED BANDWIDTH



4.3.6 EUT OPERATING CONDITIONS

The software provided by client to enable the EUT under transmission condition continuously at specific channel frequencies individually.

4.3.7 TEST RESULTS

POWER OUTPUT:

WHDI (20MHz)

CHANNEL	CHANNEL FREQUENCY (MHz)	PEAK POWER OUTPUT (mW)	PEAK POWER OUTPUT (dBm)	PEAK POWER LIMIT (dBm)	PASS/FAIL
36	5180	39.8	16.0	17	PASS
40	5200	40.7	16.1	17	PASS
48	5240	39.8	16.0	17	PASS

WHDI (40MHz)

CHANNEL	CHANNEL FREQUENCY (MHz)	PEAK POWER OUTPUT (mW)	PEAK POWER OUTPUT (dBm)	PEAK POWER LIMIT (dBm)	PASS/FAIL
38	5190	39.8	16.0	17	PASS
46	5230	40.7	16.1	17	PASS



A D T

26dB OCCUPIED BANDWIDTH:

WHDI (20MHz)

CHANNEL	CHANNEL FREQUENCY (MHz)	26dBc OCCUPIED BANDWIDTH (MHz)	PASS / FAIL
36	5180	19.69	PASS
40	5200	19.66	PASS
48	5240	19.48	PASS

CH 36

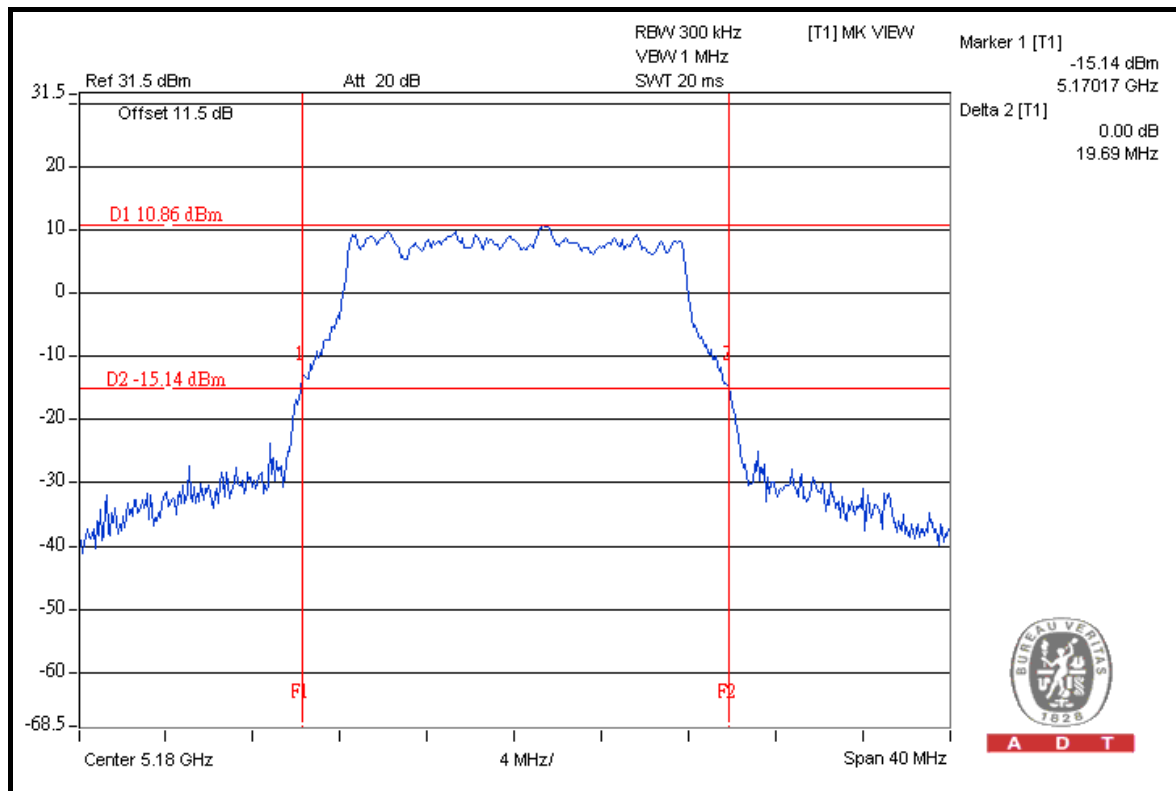



A D T

WHDI (40MHz)

CHANNEL	CHANNEL FREQUENCY (MHz)	26dBc OCCUPIED BANDWIDTH (MHz)	PASS / FAIL
38	5190	38.63	PASS
46	5230	38.75	PASS

CH 46

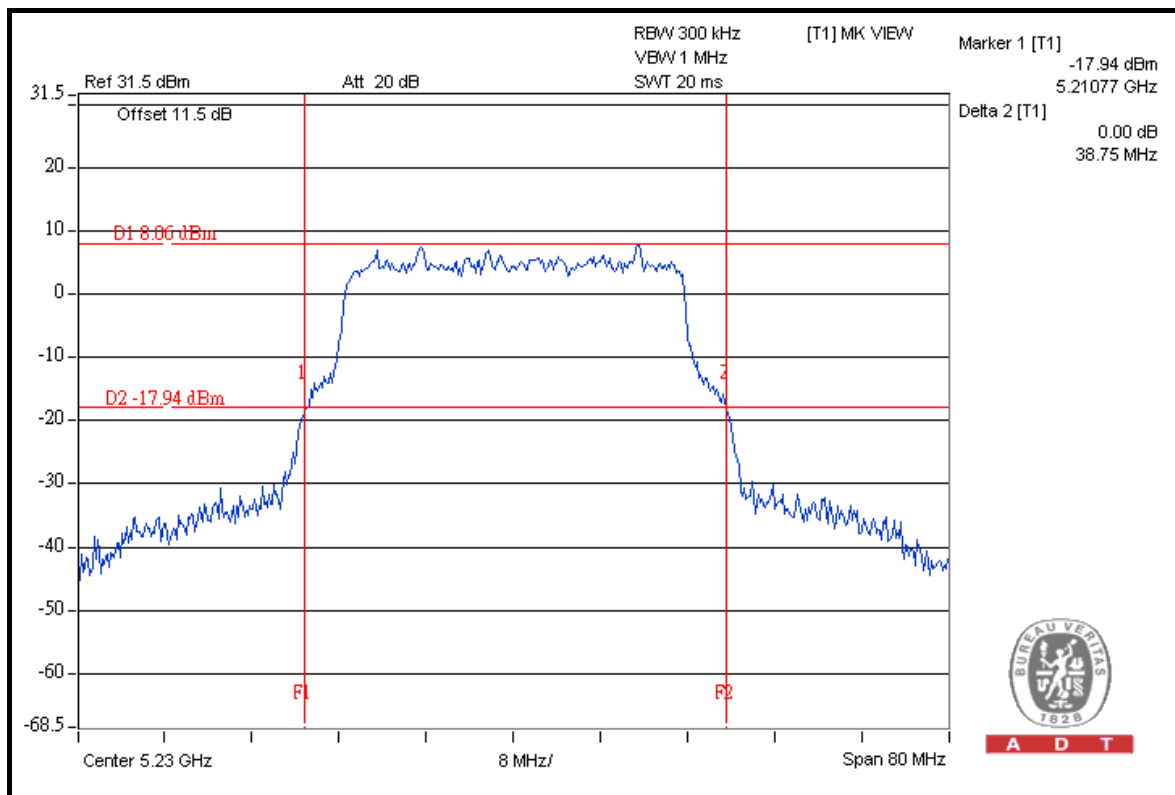

4.4 PEAK POWER EXCURSION MEASUREMENT

4.4.1 LIMITS OF PEAK POWER EXCURSION MEASUREMENT

FREQUENCY BAND	LIMIT
5.15 ~ 5.25GHz	13dB

4.4.2 TEST INSTRUMENTS

DESCRIPTION & MANUFACTURER	MODEL NO.	SERIAL NO.	DATE OF CALIBRATION	DUE DATE OF CALIBRATION
SPECTRUM ANALYZER R&S	FSP40	100040	Jul. 17, 2010	Jul. 16, 2011

NOTE: The calibration interval of the above test instruments is 12 months and the calibrations are traceable to NML/ROC and NIST/USA.

4.4.3 TEST PROCEDURE

- a. The transmitter output was connected to the spectrum analyzer.
- b. Set the spectrum bandwidth span to view the entire spectrum.
- c. Using peak detector and Max-hold function for Trace 1 (RB = 1MHz, VB = 3MHz) and 2 (RB = 1MHz, VB = 300kHz).
- d. The differences between Trace1 and Trace 2 in any 1MHz band at f1 to f2 range were recorded and showed to another trace.

4.4.4 DEVIATION FROM TEST STANDARD

No deviation.

4.4.5 TEST SETUP

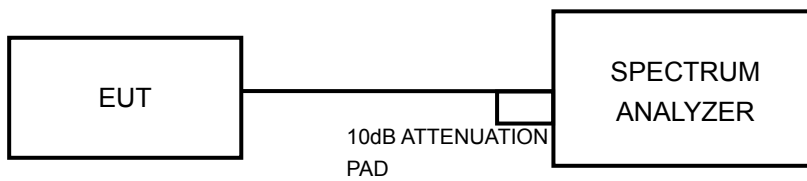

4.4.6 EUT OPERATING CONDITIONS

The software provided by client to enable the EUT under transmission condition continuously at specific channel frequencies individually.



A D T

4.4.7 TEST RESULTS

WHDI (20MHz)

CHANNEL	CHANNEL FREQUENCY (MHz)	PEAK POWER EXCURSION (dB)	PEAK to AVERAGE EXCURSION LIMIT (dB)	PASS/FAIL
36	5180	12.06	13	PASS
40	5200	12.17	13	PASS
48	5240	12.09	13	PASS



A D T

CH 40

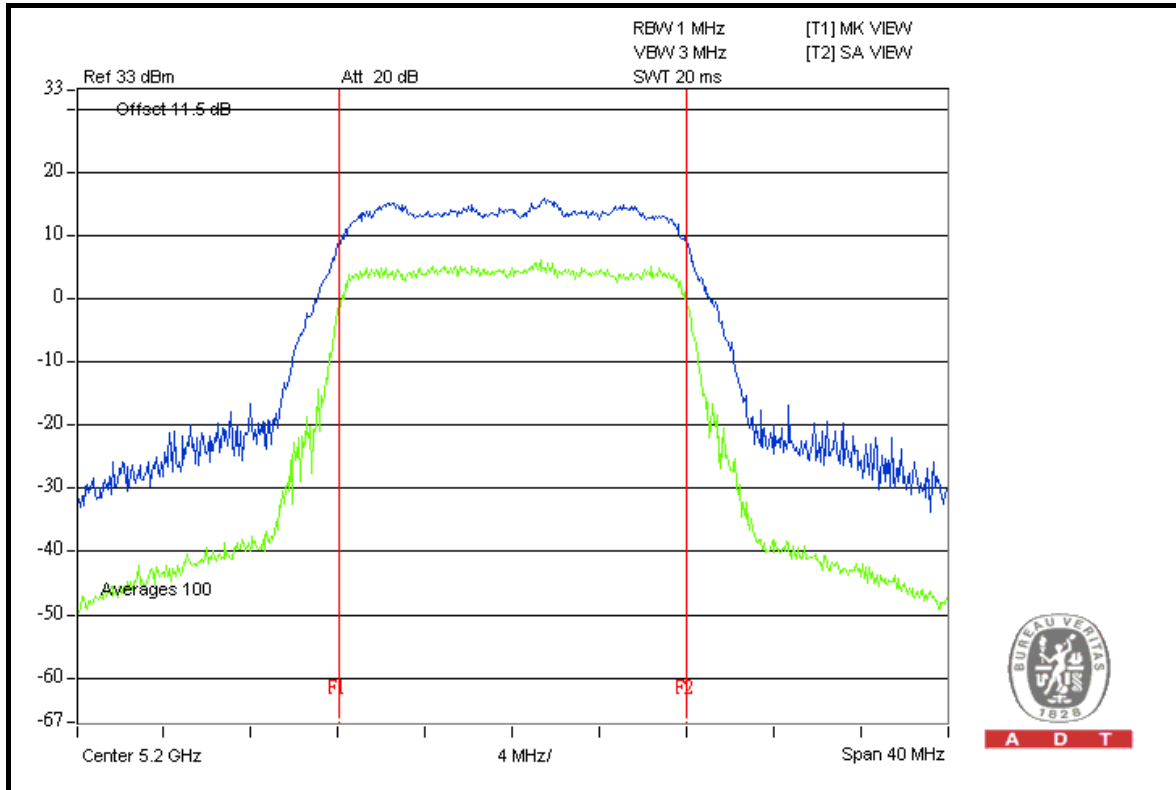

A D T

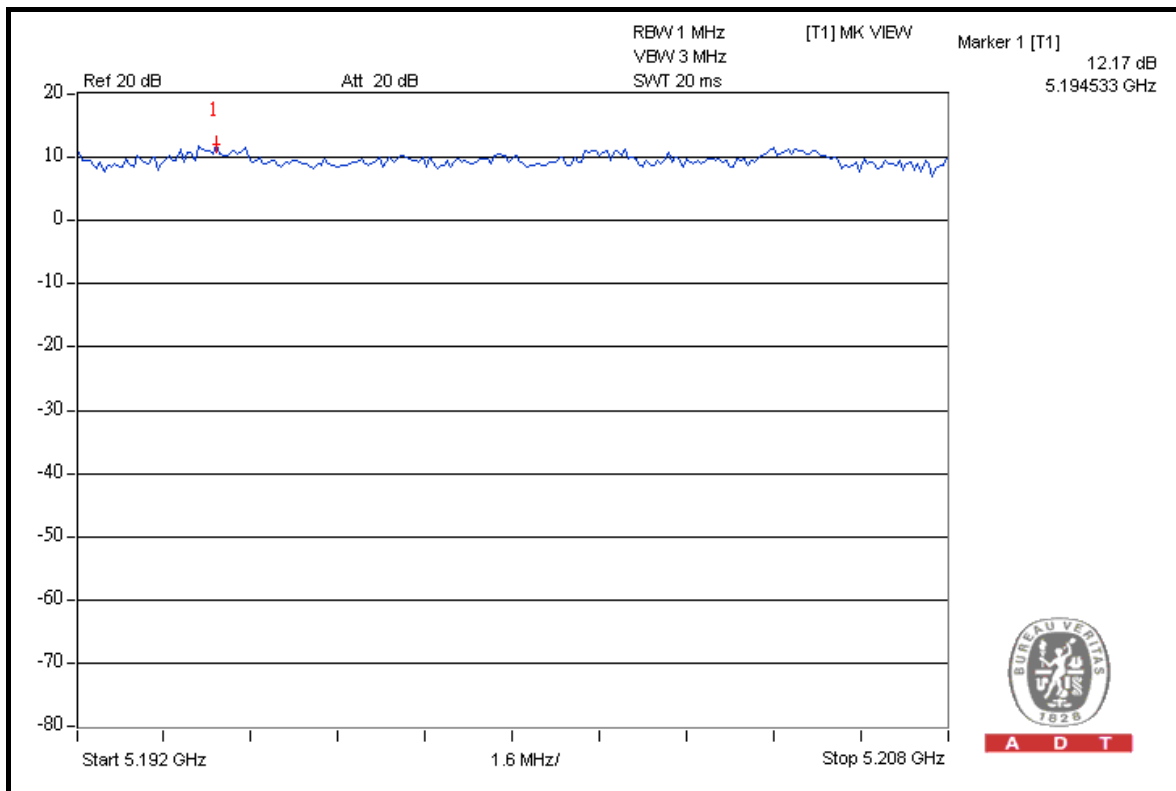

A D T



A D T

WHDI (40MHz)

CHANNEL	CHANNEL FREQUENCY (MHz)	PEAK POWER EXCURSION (dB)	PEAK to AVERAGE EXCURSION LIMIT (dB)	PASS/FAIL
38	5190	11.70	13	PASS
46	5230	11.73	13	PASS



A D T

CH 46

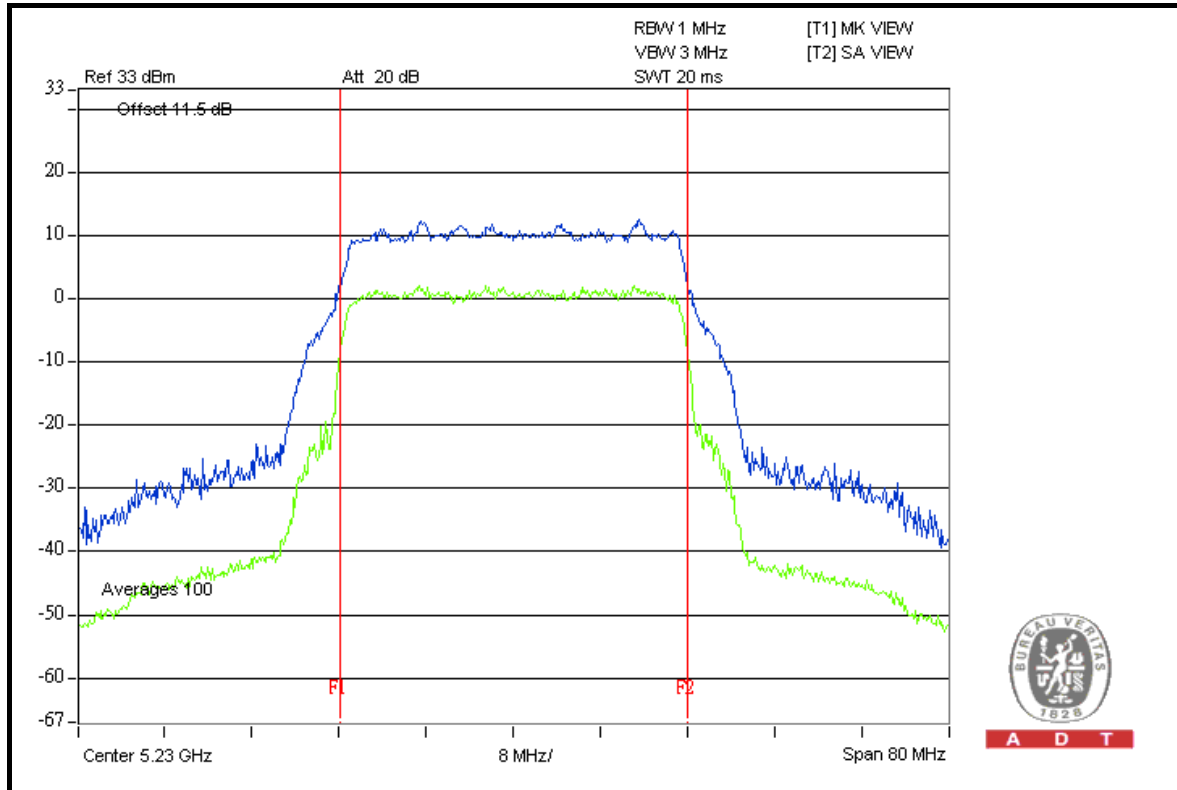

A D T

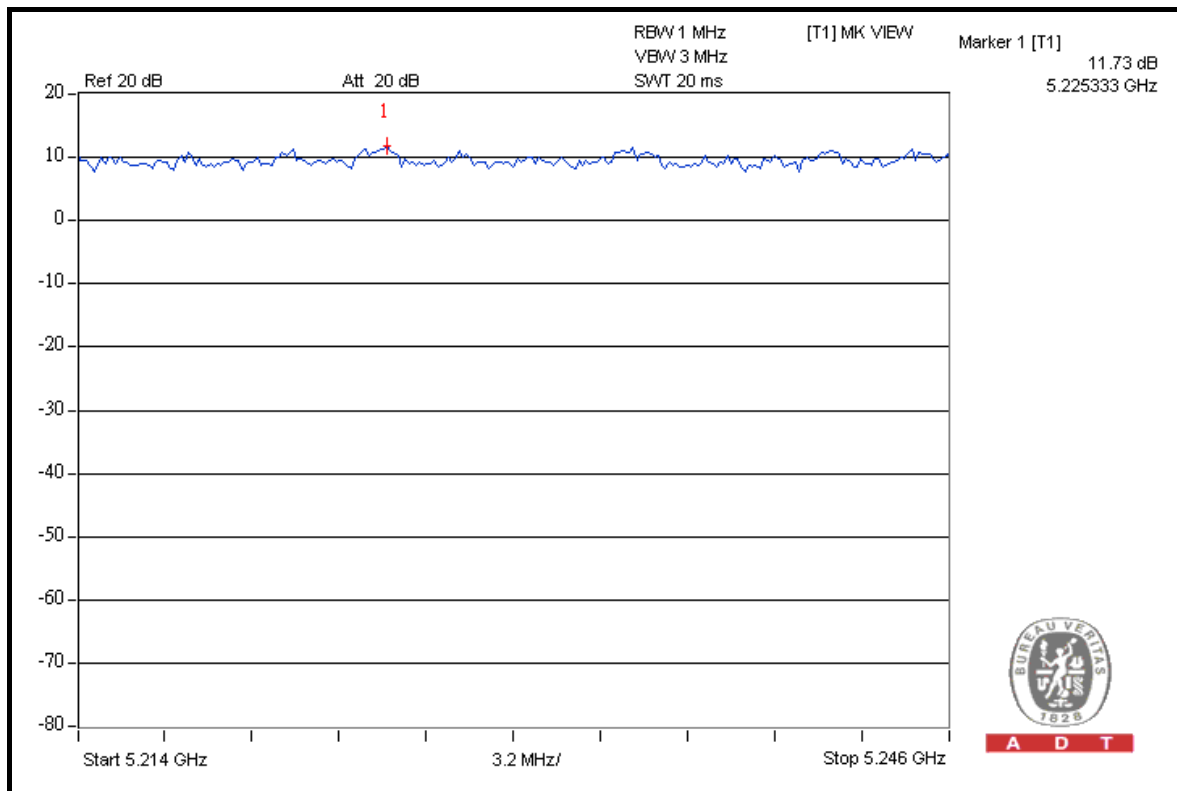

A D T

4.5 PEAK POWER SPECTRAL DENSITY MEASUREMENT

4.5.1 LIMITS OF PEAK POWER SPECTRAL DENSITY MEASUREMENT

FREQUENCY BAND	LIMIT
5.150 ~ 5.250GHz	4dBm

4.5.2 TEST INSTRUMENTS

DESCRIPTION & MANUFACTURER	MODEL NO.	SERIAL NO.	DATE OF CALIBRATION	DUE DATE OF CALIBRATION
SPECTRUM ANALYZER R&S	FSP40	100039	Jan. 11, 2011	Jan. 10, 2012

NOTE: The calibration interval of the above test instruments is 12 months and the calibrations are traceable to NML/ROC and NIST/USA.

4.5.3 TEST PROCEDURES

- a. The transmitter output was connected to the spectrum analyzer.
- b. Set RBW = 1MHz, VBW = 3MHz. The PPSD is the highest level found across the emission in any 1MHz band.

4.5.4 DEVIATION FROM TEST STANDARD

No deviation.

4.5.5 TEST SETUP

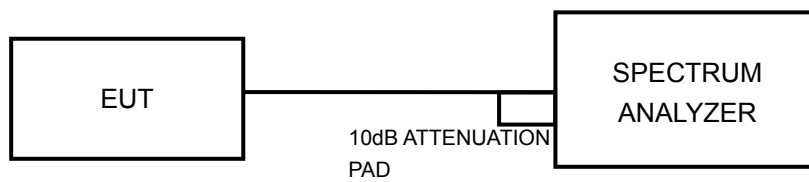

4.5.6 EUT OPERATING CONDITIONS

Same as 5.3.6.



A D T

4.5.7 TEST RESULTS

WHDI (20MHz)

CHANNEL	CHANNEL FREQUENCY (MHz)	RF POWER LEVEL IN 3 kHz BW (dBm)	MAXIMUM LIMIT (dBm)	PASS/FAIL
36	5180	3.7	4	PASS
40	5200	3.7	4	PASS
48	5240	3.7	4	PASS

CH 48

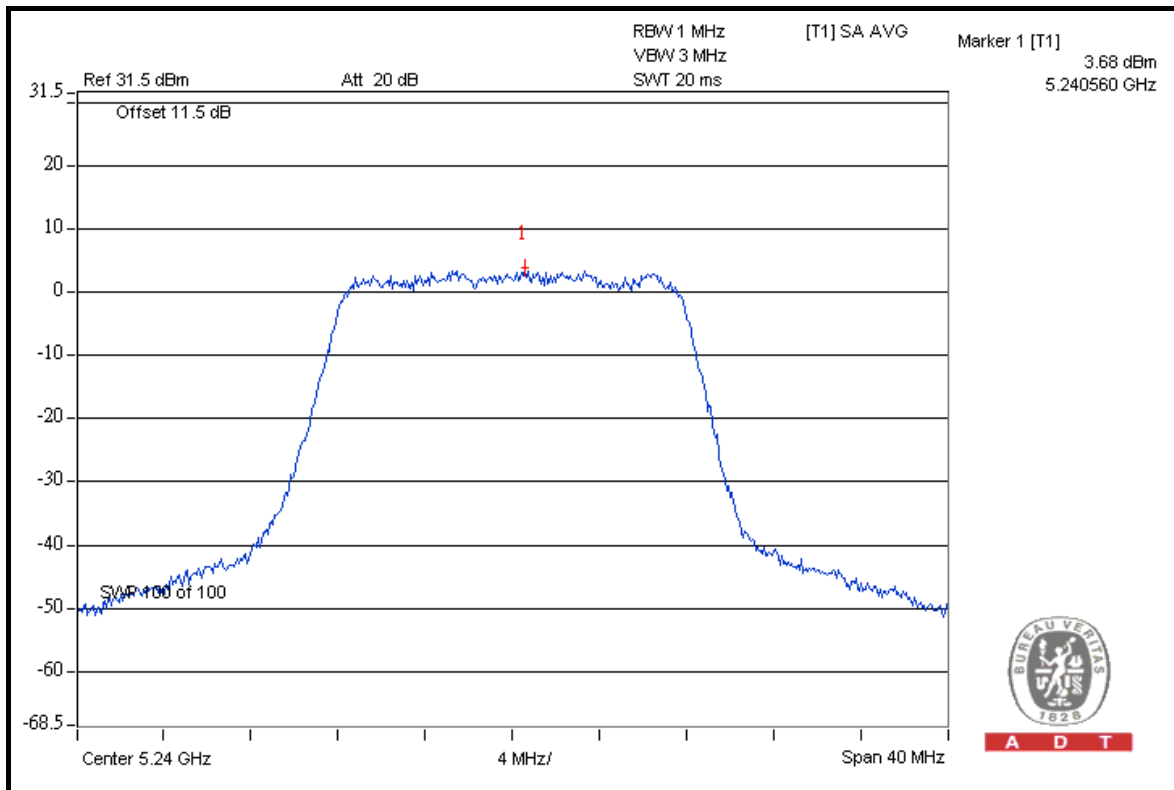



A D T

WHDI (40MHz)

CHANNEL	CHANNEL FREQUENCY (MHz)	RF POWER LEVEL IN 3 kHz BW (dBm)	MAXIMUM LIMIT (dBm)	PASS/FAIL
38	5190	0.6	4	PASS
46	5230	0.7	4	PASS

CH 46

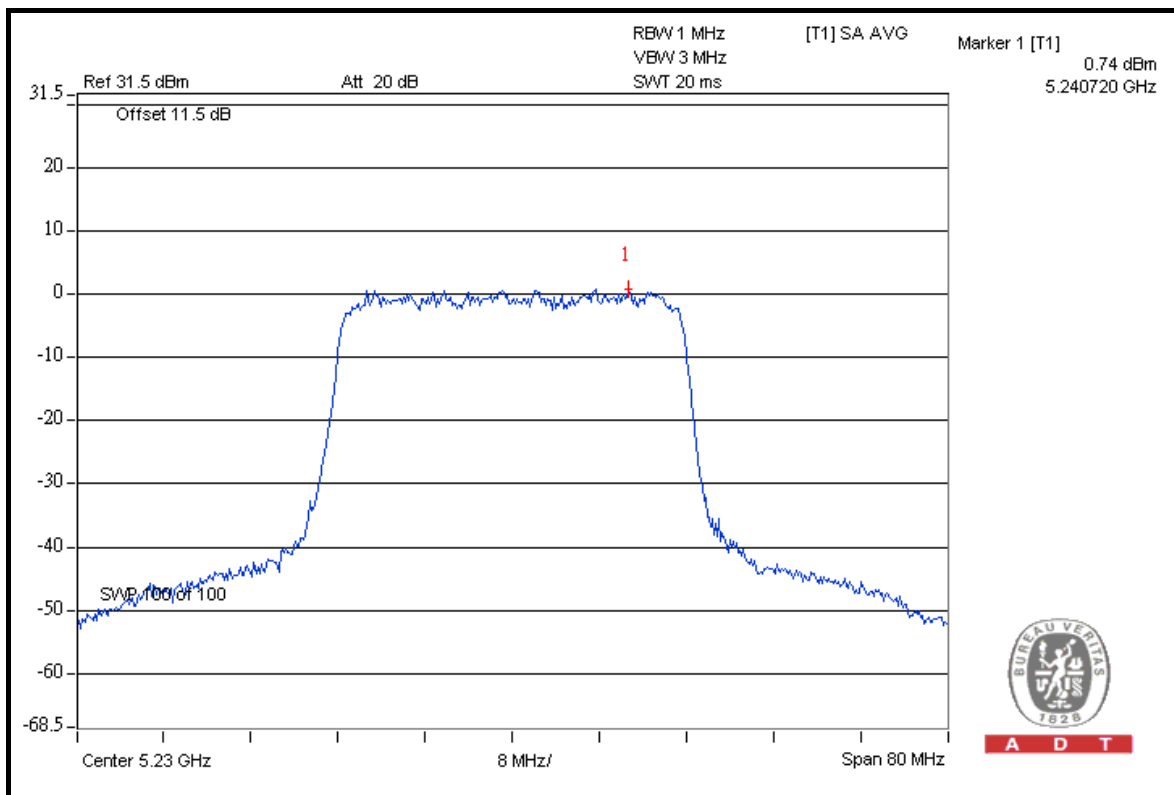

4.6 FREQUENCY STABILITY

4.6.1 LIMITS OF FREQUENCY STABILITY MEASUREMENT

The frequency tolerance of the carrier signal shall be maintained within the band of operation frequency over a temperature variation of –30 degrees to 55 degrees C at normal supply voltage, and for a variation in the primary supply voltage from 85% to 115% of the rated supply voltage at a temperature of 20 degrees C.

4.6.2 TEST INSTRUMENTS

DESCRIPTION & MANUFACTURER	MODEL NO.	SERIAL NO.	DATE OF CALIBRATION	DUE DATE OF CALIBRATION
SPECTRUM ANALYZER R&S	FSP40	100040	Jul. 17, 2010	Jul. 16, 2011
WIT STANDARD TEMPERATURE AND HUMIDITY CHAMBER	TH-4S-C	W981030	Jun. 15, 2011	Jun. 14, 2012

NOTE: The calibration interval of the above test instruments is 12 months and the calibrations are traceable to NML/ROC and NIST/USA.

4.6.3 TEST PROCEDURE

- a. The EUT was placed inside the environmental test chamber and powered by nominal DC voltage.
- b. Turn the EUT on and couple its output to a spectrum analyzer.
- c. Turn the EUT off and set the chamber to the highest temperature specified.
- d. Allow sufficient time (approximately 30 min) for the temperature of the chamber to stabilize, turn the EUT on and measure the operating frequency after 2, 5, and 10 minutes.
- e. Repeat step 2 and 3 with the temperature chamber set to the lowest temperature.
- f. The test chamber was allowed to stabilize at +20 degree C for a minimum of 30 minutes. The supply voltage was then adjusted on the EUT from 85% to 115% and the frequency record.

4.6.4 DEVIATION FROM TEST STANDARD

No deviation.

4.6.5 TEST SETUP

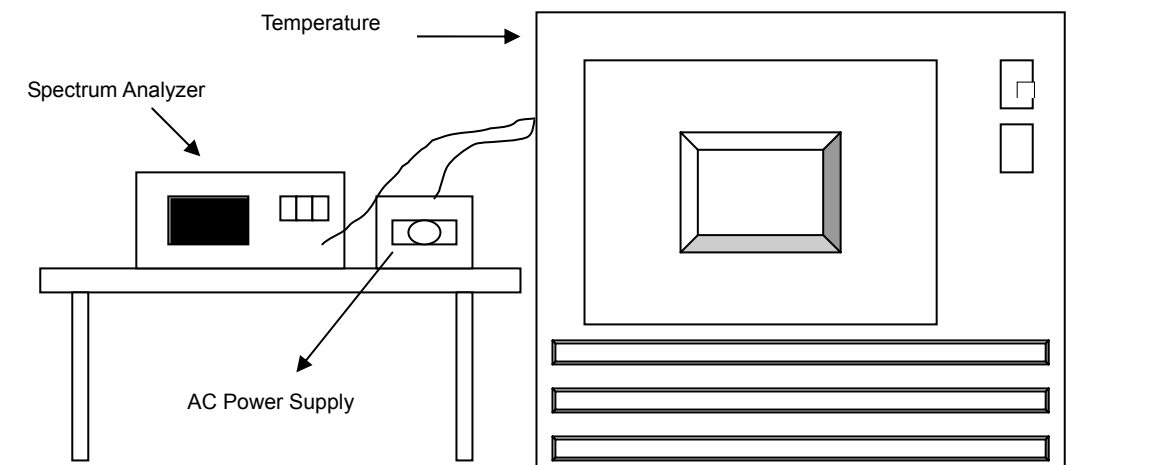

4.6.6 EUT OPERATING CONDITION

Same as Item 4.1.6.

4.6.7 TEST RESULTS

FREQUENCY STABILITY VERSUS TEMP.									
OPERATING FREQUENCY: 5200MHz									
TEMP. (°C)	POWER SUPPLY (Vdc)	0 MINUTE		2 MINUTE		5 MINUTE		10 MINUTE	
		Measured Frequency (MHz)	Frequency Drift (ppm)	Measured Frequency (MHz)	Frequency Drift (ppm)	Measured Frequency (MHz)	Frequency Drift (ppm)	Measured Frequency (MHz)	Frequency Drift (ppm)
55	110.0	5200.001782	0.343	5200.002160	0.415	5200.001835	0.353	5200.001956	0.376
50	110.0	5200.002051	0.394	5200.001817	0.349	5200.001873	0.360	5200.002540	0.488
40	110.0	5200.002853	0.549	5200.003056	0.588	5200.002995	0.576	5200.002944	0.566
30	110.0	5200.043032	8.275	5200.043400	8.346	5200.043010	8.271	5200.043226	8.313
20	110.0	5200.007195	1.384	5200.007350	1.413	5200.007388	1.421	5200.007450	1.433
10	110.0	5200.002651	0.510	5200.002924	0.562	5200.003052	0.587	5200.002739	0.527
0	110.0	5200.000691	0.133	5200.000883	0.170	5200.001075	0.207	5200.000862	0.166
-10	110.0	5200.007466	1.436	5200.007349	1.413	5200.007327	1.409	5200.007925	1.524
-20	110.0	5200.025243	4.854	5200.025443	4.893	5200.025316	4.868	5200.025747	4.951
-30	110.0	5200.039325	7.563	5200.039548	7.605	5200.039567	7.609	5200.039254	7.549

FREQUENCY STABILITY VERSUS VOLTAGE									
OPERATING FREQUENCY: 5200MHz									
TEMP. (°C)	POWER SUPPLY (Vdc)	0 MINUTE		2 MINUTE		5 MINUTE		10 MINUTE	
		Measured Frequency (MHz)	Frequency Drift (ppm)	Measured Frequency (MHz)	Frequency Drift (ppm)	Measured Frequency (MHz)	Frequency Drift (ppm)	Measured Frequency (MHz)	Frequency Drift (ppm)
20	93.5	5200.043361	8.339	5200.042993	8.268	5200.043280	8.323	5200.043275	8.322
	110.0	5200.007195	1.384	5200.007350	1.413	5200.007388	1.421	5200.007450	1.433
	126.5	5200.002892	0.556	5200.002722	0.523	5200.002711	0.521	5200.002931	0.564

4.7 BAND EDGES MEASUREMENT

4.7.1 TEST INSTRUMENTS

DESCRIPTION & MANUFACTURER	MODEL NO.	SERIAL NO.	DATE OF CALIBRATION	DUE DATE OF CALIBRATION
SPECTRUM ANALYZER R&S	FSP40	100040	Jul. 17, 2010	Jul. 16, 2011

NOTE: The calibration interval of the above test instruments is 12 months and the calibrations are traceable to NML/ROC and NIST/USA.

4.7.2 TEST PROCEDURE

The transmitter output was connected to the spectrum analyzer via a low lose cable. Set both RBW and VBW of spectrum analyzer to 1MHz and 3MHz with suitable frequency span including 100MHz bandwidth from band edge. The band edges was measured and recorded.

4.7.3 EUT OPERATING CONDITION

The software provided by client to enable the EUT under transmission condition continuously at specific channel frequencies individually.

4.7.4 TEST RESULTS

For signals in the restricted bands above and below the 5.15 to 5.25GHz allocated band a measurement was made of the amplitude of the spurious emissions with respect to the intentional signals. The relative amplitude, in dBc, was applied to the average and peak field strength of the intentional signal made on the OATS to calculate the field strength of the unintentional signals.

The spectrum plots (Peak RBW = 1MHz, VBW = 3MHz) are attached on the following pages.

WHDI (20MHz)

RESTRICT BAND (4500 ~ 5150 MHz)

FREQUENCY (MHz)	FUNDAMENTAL EMISSION (dBuV/m)	DELTA (dB)	MAXIMUM FIELD STRENGTH IN RESTRICT BAND (dBuV/m)	LIMIT (dBuV/m)
5180.00 (PK)	110.60	55.47	55.13	74.00
5180.00 (AV)	97.30	55.28	42.02	54.00

RESTRICT BAND (5350 ~ 5460 MHz)

FREQUENCY (MHz)	FUNDAMENTAL EMISSION (dBuV/m)	DELTA (dB)	MAXIMUM FIELD STRENGTH IN RESTRICT BAND (dBuV/m)	LIMIT (dBuV/m)
5240.00 (PK)	110.60	57.29	53.31	74.00
5240.00 (AV)	96.80	56.58	40.22	54.00

NOTE:

1. Delta = Amplitude between the peak of the fundamental and the peak of the band edge emission. Please check following 3 pages.
2. Maximum field strength in restrict band = Fundamental emission – Delta.



A D T

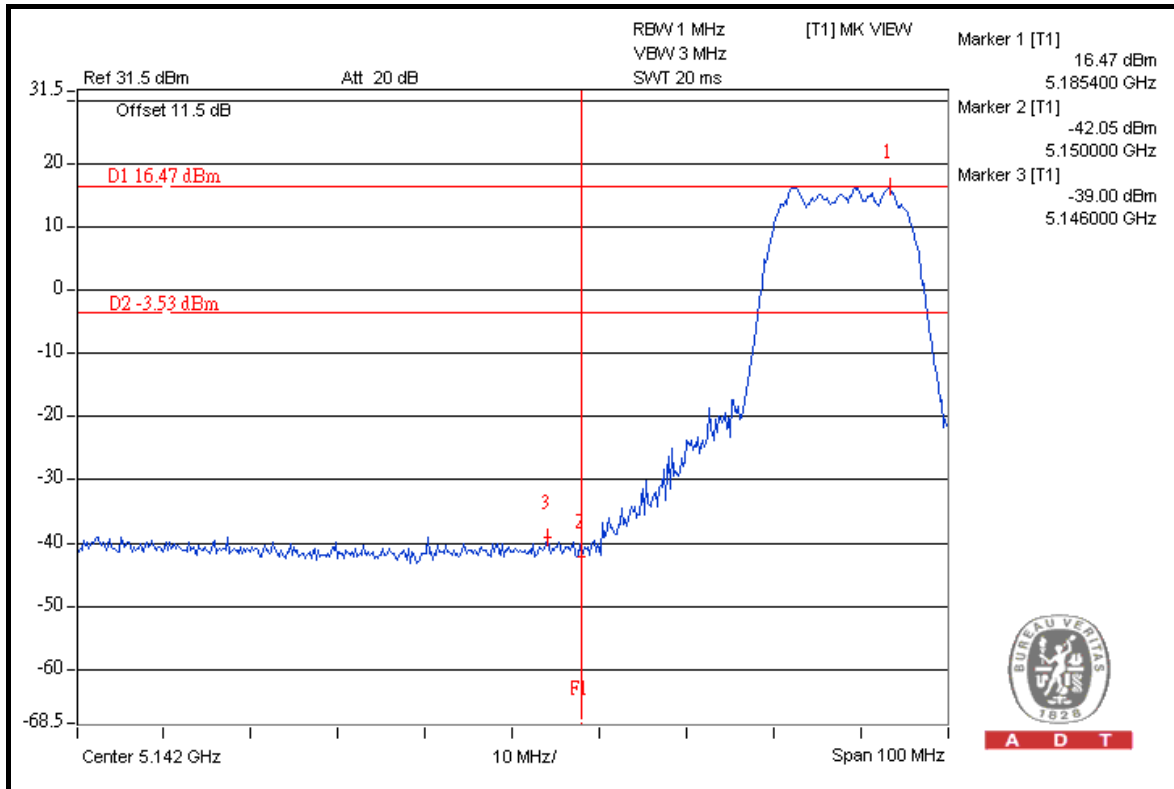

A D T

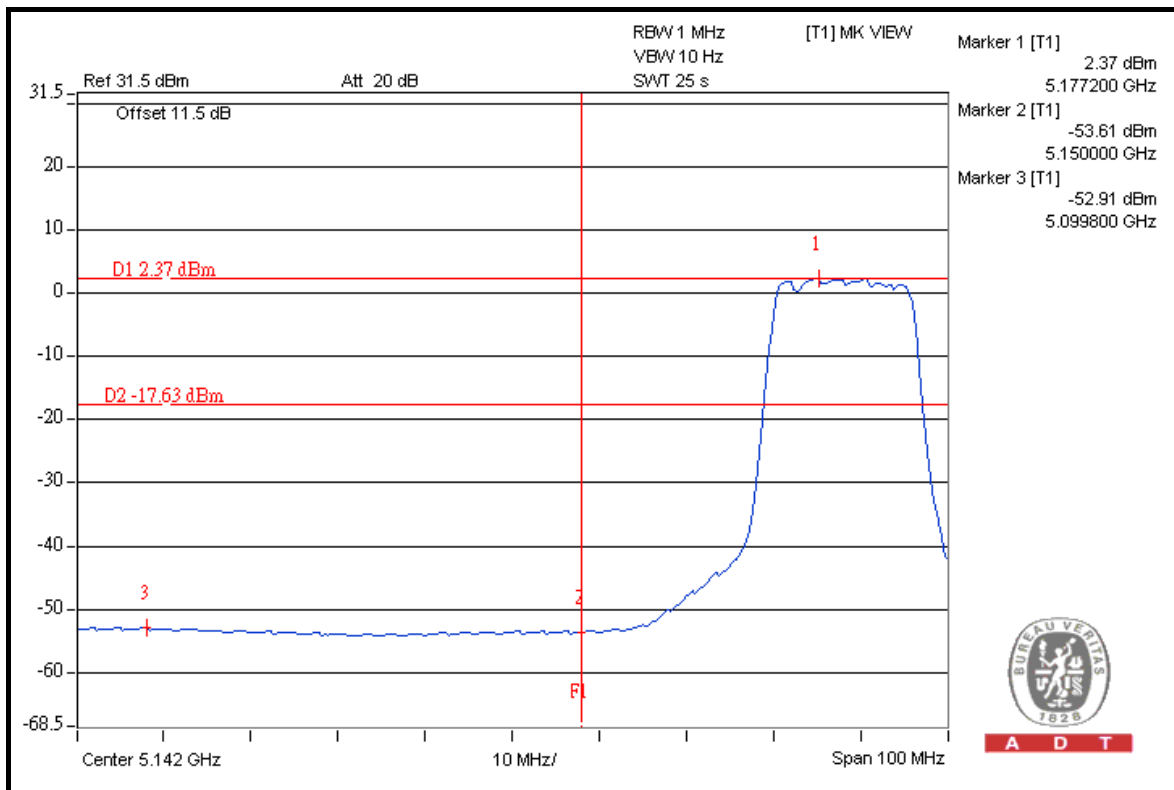

A D T



A D T

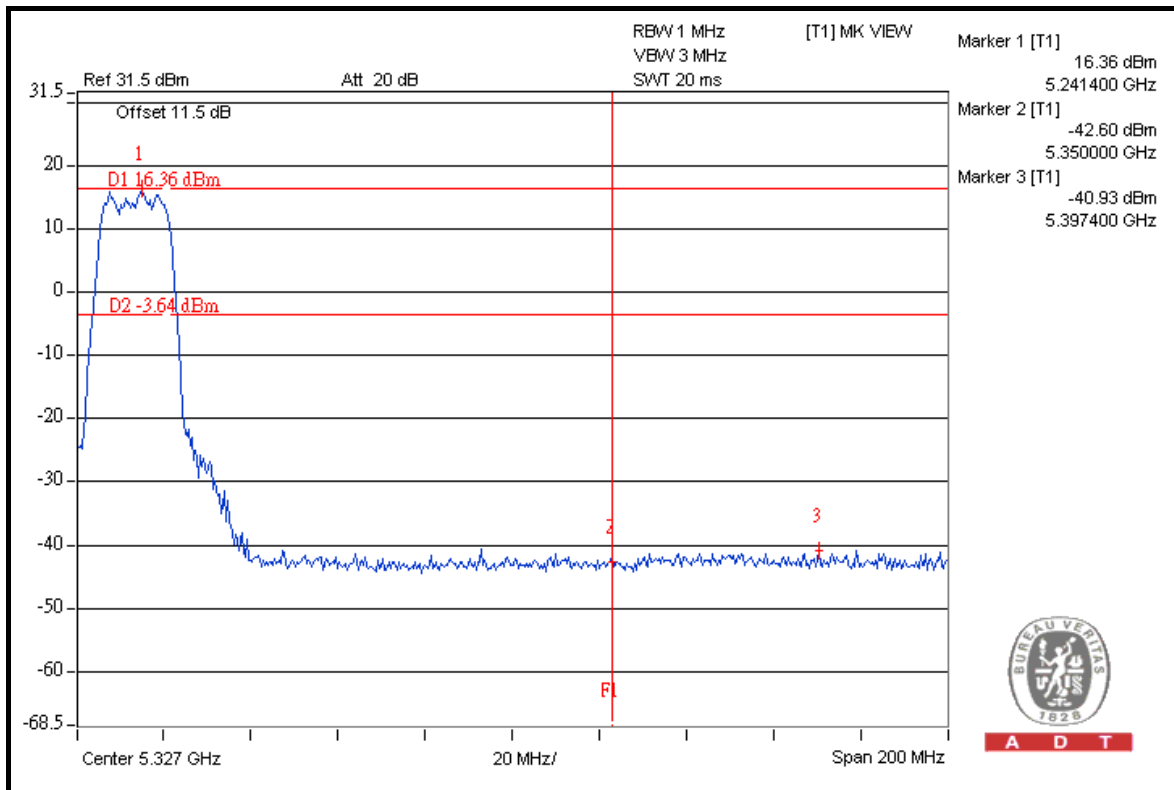
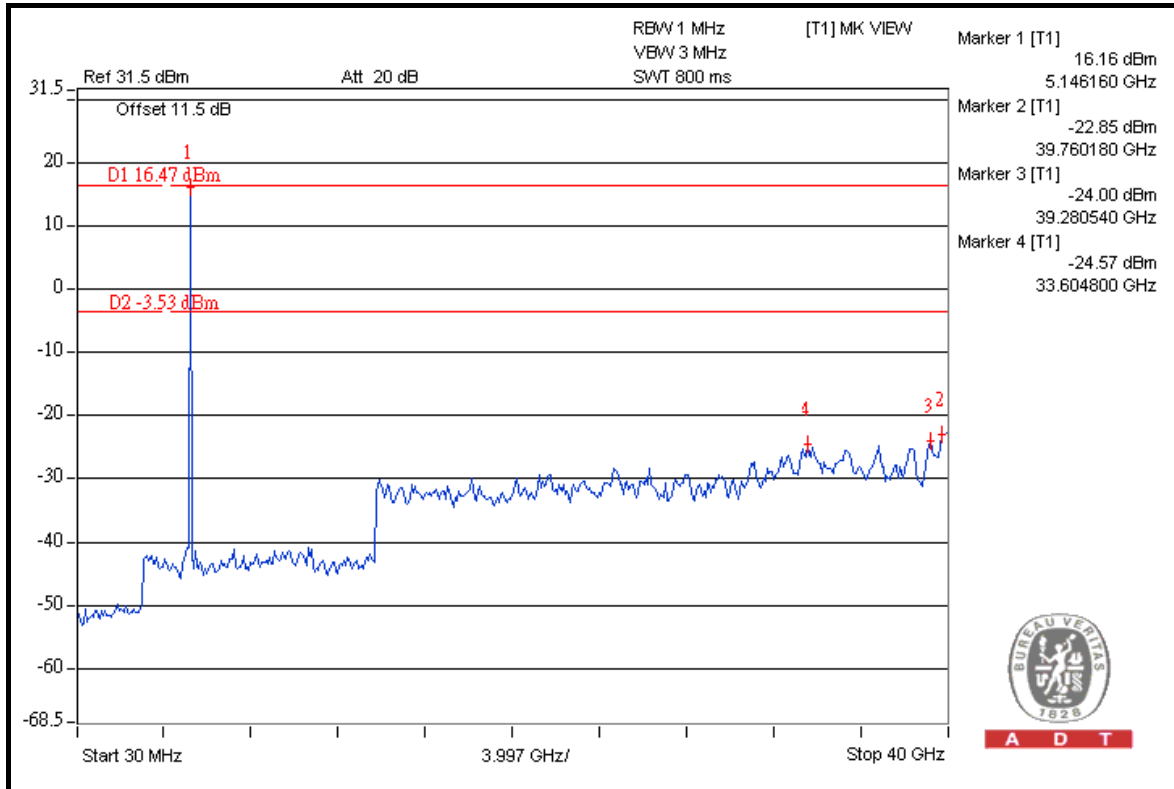



A D T

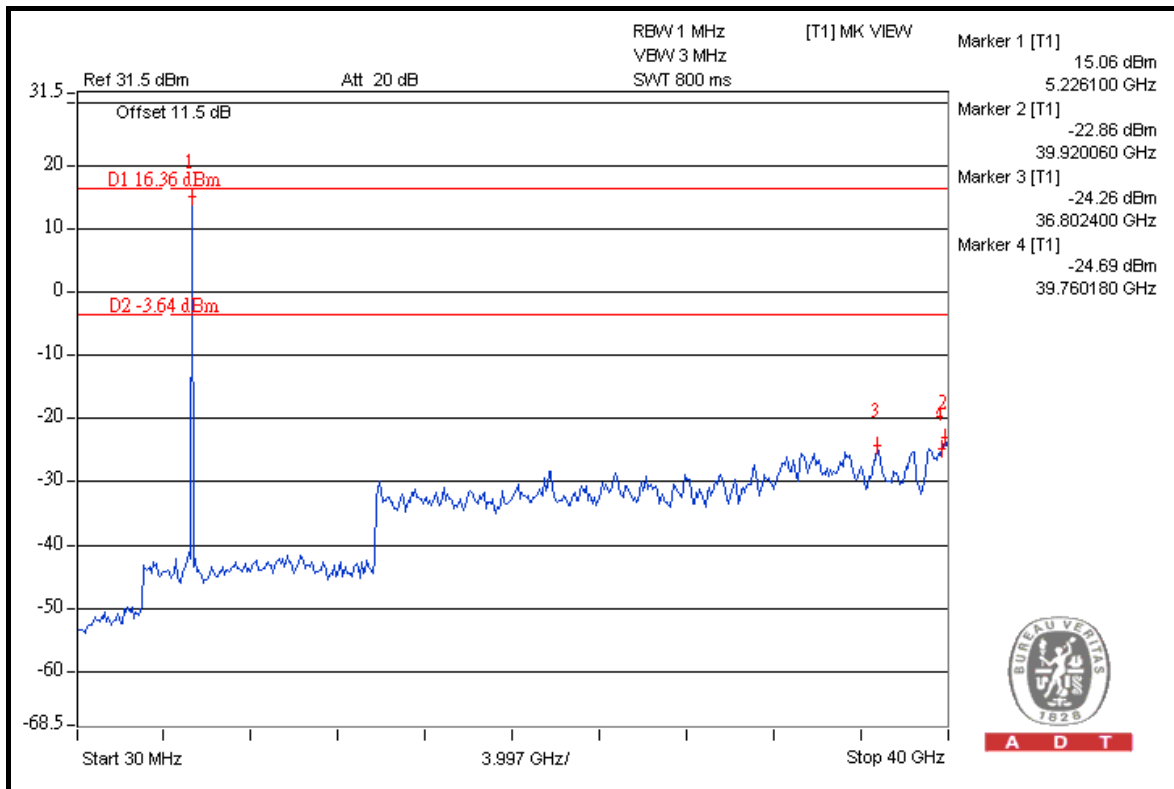
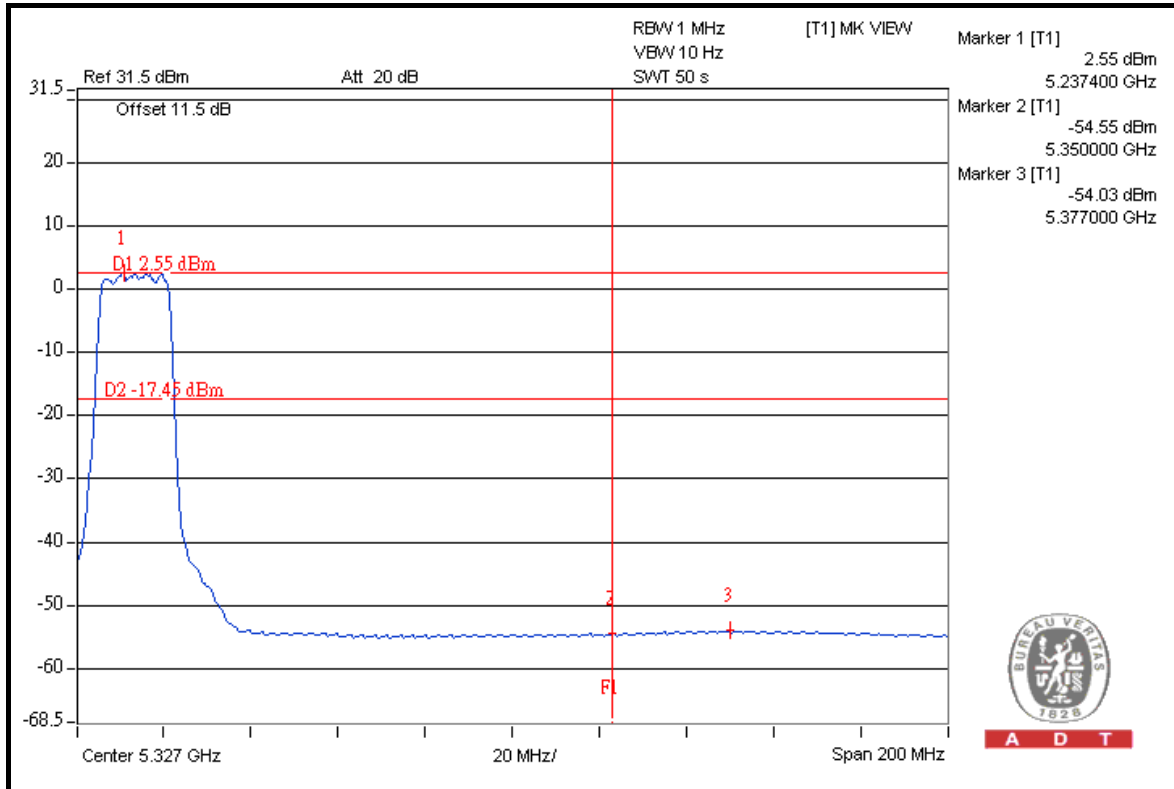

WHDI (40MHz)

RESTRICT BAND (4500 ~ 5150 MHz)

FREQUENCY (MHz)	FUNDAMENTAL EMISSION (dBuV/m)	DELTA (dB)	MAXIMUM FIELD STRENGTH IN RESTRICT BAND (dBuV/m)	LIMIT (dBuV/m)
5190.00 (PK)	106.40	46.79	59.61	74.00
5190.00 (AV)	93.80	51.32	42.48	54.00

RESTRICT BAND (5350 ~ 5460 MHz)

FREQUENCY (MHz)	FUNDAMENTAL EMISSION (dBuV/m)	DELTA (dB)	MAXIMUM FIELD STRENGTH IN RESTRICT BAND (dBuV/m)	LIMIT (dBuV/m)
5230.00 (PK)	106.10	53.88	52.22	74.00
5230.00 (AV)	93.50	54.36	39.14	54.00

NOTE:

- Delta = Amplitude between the peak of the fundamental and the peak of the band edge emission. Please check following 3 pages.
- Maximum field strength in restrict band = Fundamental emission – Delta.



A D T

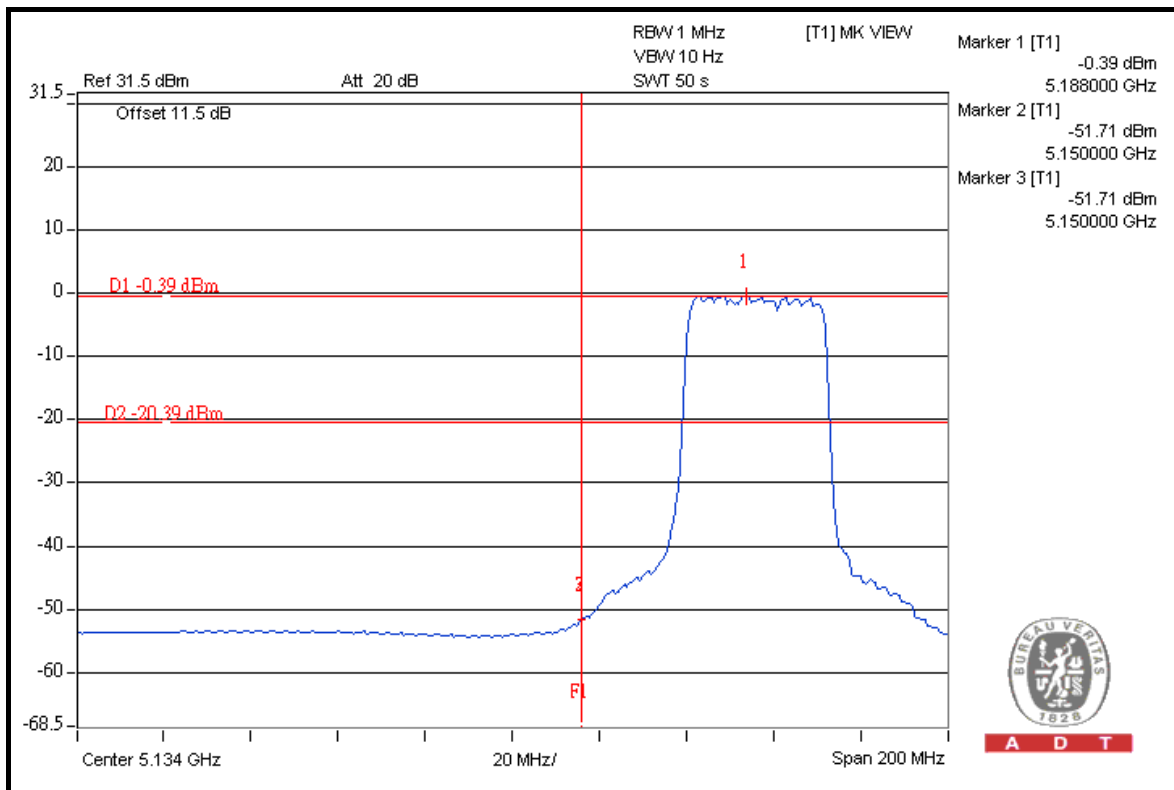
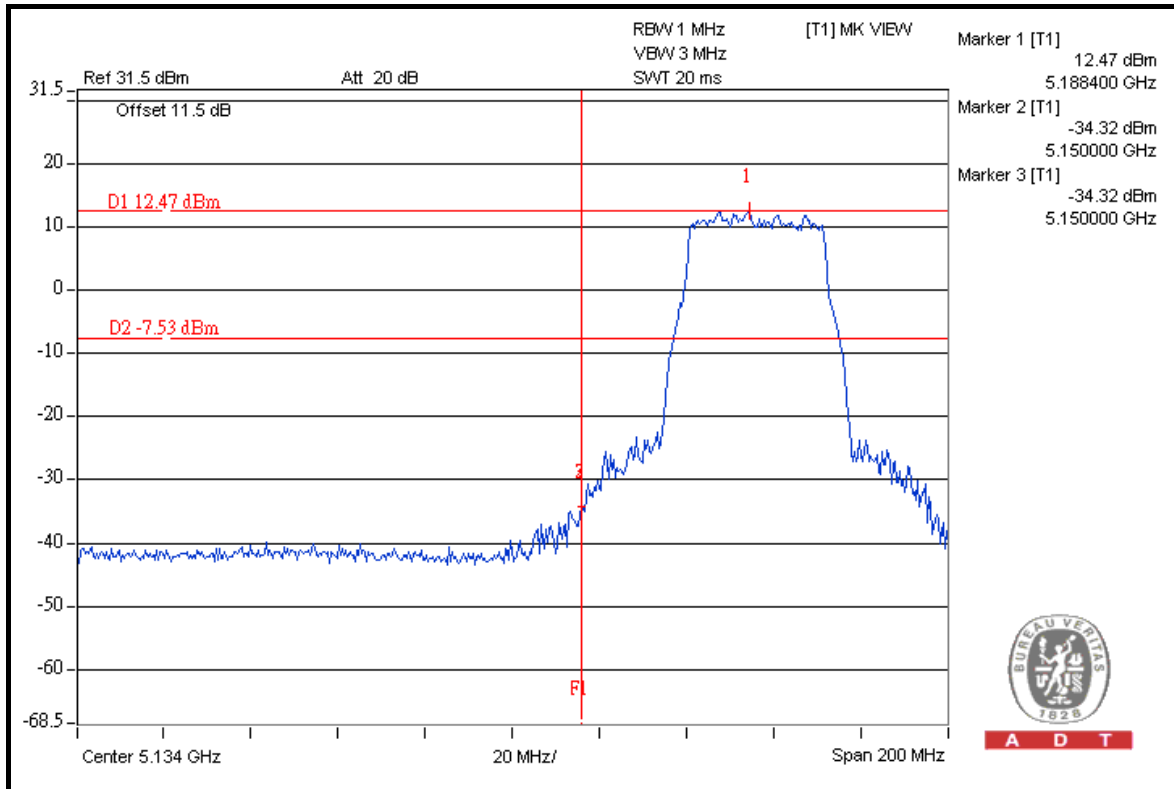



A D T

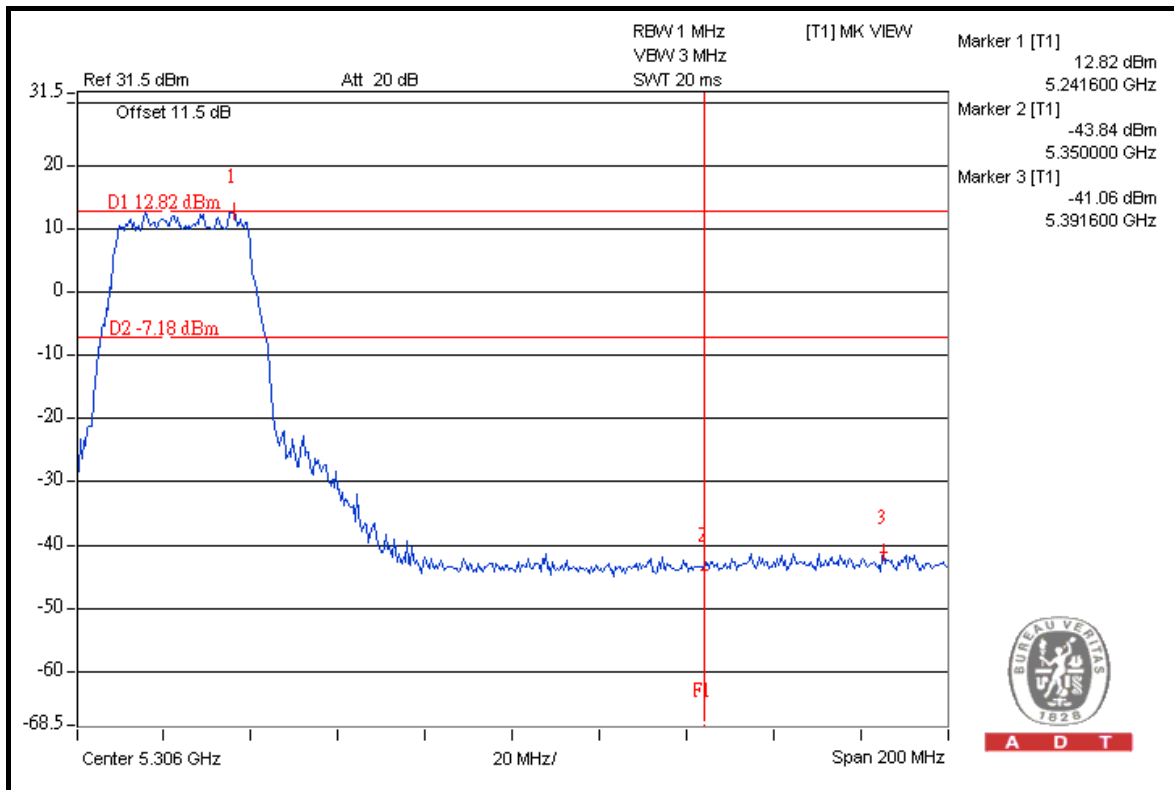
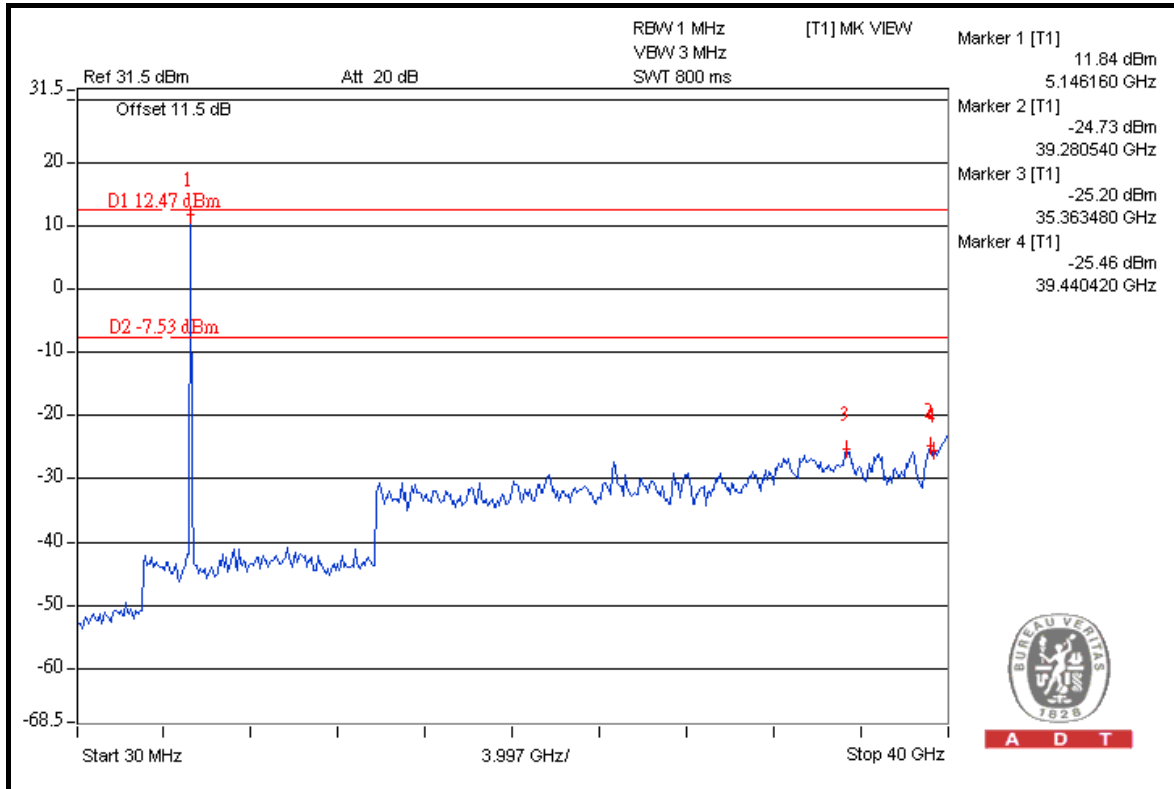



A D T

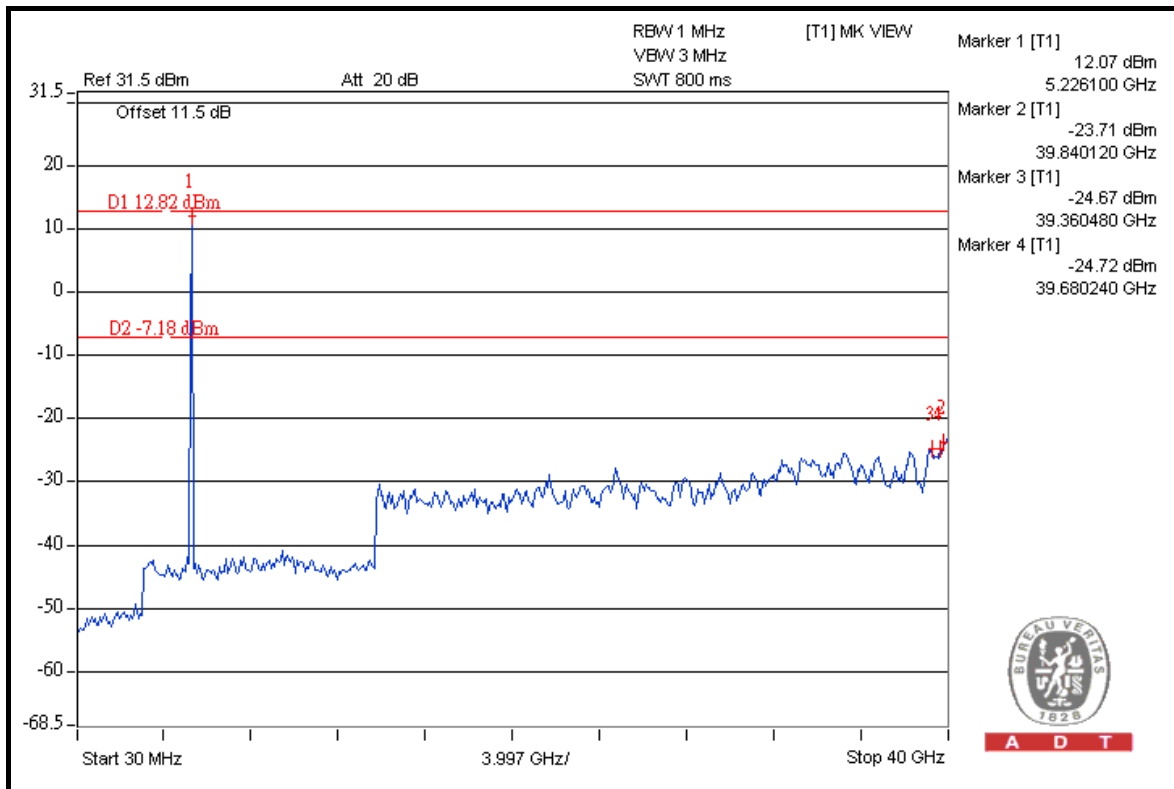
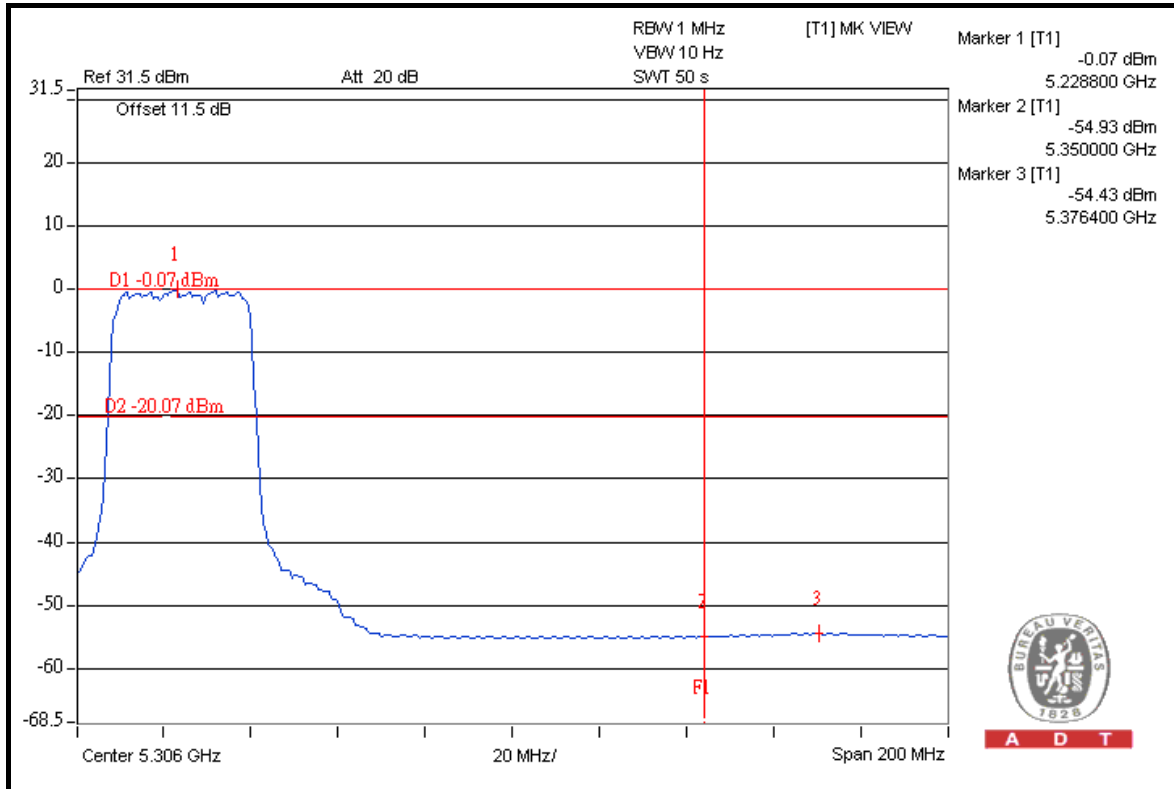

5. PHOTOGRAPHS OF THE TEST CONFIGURATION

Please refer to the attached file (Test Setup Photo).



6. INFORMATION ON THE TESTING LABORATORIES

We, Bureau Veritas Consumer Products Services (H.K.) Ltd., Taoyuan Branch, were founded in 1988 to provide our best service in EMC, Radio, Telecom and Safety consultation. Our laboratories are accredited and approved according to ISO/IEC 17025.

Copies of accreditation certificates of our laboratories obtained from approval agencies can be downloaded from our web site: <http://www.adt.com.tw/index.5.phtml>. If you have any comments, please feel free to contact us at the following:

Linko EMC/RF Lab

Tel: 886-2-26052180

Fax: 886-2-26051924

Hsin Chu EMC/RF Lab

Tel: 886-3-5935343

Fax: 886-3-5935342

Hwa Ya EMC/RF/Safety/Telecom Lab

Tel: 886-3-3183232

Fax: 886-3-3185050

Email: service.adt@tw.bureauveritas.com

Web Site: www.adt.com.tw

The address and road map of all our labs can be found in our web site also.

7. APPENDIX A - MODIFICATIONS RECORDERS FOR ENGINEERING CHANGES TO THE EUT BY THE LAB

No any modifications are made to the EUT by the lab during the test.

---END---