

## FCC Test Report

**Report No.:** RF110607C09S

**FCC ID:** YG7ZRF31200

**Test Model:** WHD200T

**Received Date:** Nov. 10, 2015

**Test Date:** Nov. 30, 2015 ~ Jun. 02, 2016

**Issued Date:** Jun. 02, 2016

**Applicant:** Zinwell Corporation

**Address:** 7F., No.512, Yuanshan Rd., Zhonghe Dist., New Taipei City 235, Taiwan  
(R.O.C.)

**Issued By:** Bureau Veritas Consumer Products Services (H.K.) Ltd., Taoyuan Branch

**Lab Address:** No. 47-2, 14th Ling, Chia Pau Vil., Lin Kou Dist., New Taipei City, Taiwan,  
R.O.C.

**Test Location:** No. 19, Hwa Ya 2nd Rd., Wen Hwa Vil., Kwei Shan Dist., Taoyuan City 33383,  
TAIWAN (R.O.C.)



This report is for your exclusive use. Any copying or replication of this report to or for any other person or entity, or use of our name or trademark, is permitted only with our prior written permission. This report sets forth our findings solely with respect to the test samples identified herein. The results set forth in this report are not indicative or representative of the quality or characteristics of the lot from which a test sample was taken or any similar or identical product unless specifically and expressly noted. Our report includes all of the tests requested by you and the results thereof based upon the information that you provided to us. You have 60 days from date of issuance of this report to notify us of any material error or omission caused by our negligence, provided, however, that such notice shall be in writing and shall specifically address the issue you wish to raise. A failure to raise such issue within the prescribed time shall constitute your unqualified acceptance of the completeness of this report, the tests conducted and the correctness of the report contents. Unless specifically mentioned, the uncertainty of measurement has been explicitly taken into account to declare the compliance or non-compliance to the specification. The report must not be used by the client to claim product certification, approval, or endorsement by TAF or any government agencies.



## Table of Contents

<b>Release Control Record</b> .....	<b>4</b>
<b>1 Certificate of Conformity</b> .....	<b>5</b>
<b>2 Summary of Test Results</b> .....	<b>6</b>
2.1 Measurement Uncertainty.....	6
2.2 Modification Record.....	6
<b>3 General Information</b> .....	<b>7</b>
3.1 General Description of EUT.....	7
3.2 Description of Test Modes.....	9
3.2.1 Test Mode Applicability and Tested Channel Detail.....	10
3.3 Duty Cycle of Test Signal.....	12
3.4 Description of Support Units.....	13
3.4.1 Configuration of System under Test.....	14
3.5 General Description of Applied Standards.....	15
<b>4 Test Types and Results</b> .....	<b>16</b>
4.1 Radiated Emission and Bandedge Measurement.....	16
4.1.1 Limits of Radiated Emission and Bandedge Measurement.....	16
4.1.2 Test Instruments.....	17
4.1.3 Test Procedures.....	19
4.1.4 Deviation from Test Standard.....	19
4.1.5 Test Set Up.....	20
4.1.6 EUT Operating Conditions.....	20
4.1.7 Test Results.....	21
4.2 Conducted Emission Measurement.....	32
4.2.1 Limits of Conducted Emission Measurement.....	32
4.2.2 Test Instruments.....	32
4.2.3 Test Procedures.....	33
4.2.4 Deviation from Test Standard.....	33
4.2.5 Test Setup.....	33
4.2.6 EUT Operating Conditions.....	33
4.2.7 Test Results.....	34
4.3 Transmit Power Measurement.....	38
4.3.1 Limits of Transmit Power Measurement.....	38
4.3.2 Test Setup.....	38
4.3.3 Test Instruments.....	38
4.3.4 Test Procedure.....	39
4.3.5 Deviation from Test Standard.....	39
4.3.6 EUT Operating Conditions.....	39
4.3.7 Test Result.....	40
4.4 Peak Power Spectral Density Measurement.....	44
4.4.1 Limits of Peak Power Spectral Density Measurement.....	44
4.4.2 Test Setup.....	44
4.4.3 Test Instruments.....	44
4.4.4 Test Procedures.....	44
4.4.5 Deviation from Test Standard.....	44
4.4.6 EUT Operating Conditions.....	44
4.4.7 Test Results.....	45
4.5 Frequency Stability.....	47
4.5.1 Limits of Frequency Stability Measurement.....	47
4.5.2 Test Setup.....	47
4.5.3 Test Instruments.....	47
4.5.4 Test Procedure.....	47
4.5.5 Deviation from Test Standard.....	47
4.5.6 EUT Operating Condition.....	47



4.5.7 Test Results .....	48
4.6 6dB Bandwidth Measurement .....	49
4.6.1 Limits of 6dB Bandwidth Measurement .....	49
4.6.2 Test Setup .....	49
4.6.3 Test Instruments .....	49
4.6.4 Test Procedure .....	49
4.6.5 Deviation from Test Standard .....	49
4.6.6 EUT Operating Condition .....	49
4.6.7 Test Results .....	50
<b>5 Pictures of Test Arrangements .....</b>	<b>51</b>
<b>Appendix – Information on the Testing Laboratories .....</b>	<b>52</b>



A D T

### Release Control Record

Issue No.	Description	Date Issued
RF110607C09S	Original release.	Jun. 02, 2016



# 1 Certificate of Conformity

**Product:** Wireless HD AV Connect Transmitter  
**Brand:** ZINWELL  
**Test Model:** WHD200T  
**Sample Status:** Engineering sample  
**Applicant:** Zinwell Corporation  
**Test Date:** Nov. 30, 2015 ~ Jun. 02, 2016  
**Standards:** 47 CFR FCC Part 15, Subpart E (Section 15.407)  
ANSI C63.10:2013

The above equipment has been tested by **Bureau Veritas Consumer Products Services (H.K.) Ltd., Taoyuan Branch**, and found compliance with the requirement of the above standards. The test record, data evaluation & Equipment Under Test (EUT) configurations represented herein are true and accurate accounts of the measurements of the sample's EMC characteristics under the conditions specified in this report.

**Prepared by :** Ivy Lin , **Date:** Jun. 02, 2016  
Ivy Lin / Specialist

**Approved by :** Ken Liu , **Date:** Jun. 02, 2016  
Ken Liu / Senior Manager

## 2 Summary of Test Results

47 CFR FCC Part 15, Subpart E (Section 15.407)			
FCC Clause	Test Item	Result	Remarks
15.207 15.407(b)(6)	AC Power Conducted Emissions	Pass	Meet the requirement of limit. Minimum passing margin is -7.41dB at 0.18906MHz.
15.407(b) (1/2/3/4/6)	Radiated Emissions & Band Edge Measurement	Pass	Meet the requirement of limit. Minimum passing margin is -0.9dB at 11020.00MHz.
15.407(a)(1/2 /3)	Max Average Transmit Power	Pass	Meet the requirement of limit.
15.407(a)(1/2 /3)	Peak Power Spectral Density	Pass	Meet the requirement of limit.
15.407(e)	6dB bandwidth	Pass	Meet the requirement of limit. (U-NII-3 Band only)
15.407(g)	Frequency Stability	Pass	Meet the requirement of limit.
15.203	Antenna Requirement	Pass	No antenna connector is used.

### 2.1 Measurement Uncertainty

Where relevant, the following measurement uncertainty levels have been estimated for tests performed on the EUT as specified in CISPR 16-4-2:

Measurement	Frequency	Expanded Uncertainty (k=2) (
-------------	-----------	------------------------------

### 3 General Information

#### 3.1 General Description of EUT

Product	Wireless HD AV Connect Transmitter
Brand	ZINWELL
Test Model	WHD200T
Status of EUT	Engineering sample
Power Supply Rating	5Vdc from adapter
Modulation Technology	OFDM
Operating Frequency	5190 ~ 5230MHz, 5270 ~ 5310MHz, 5510 ~ 5670MHz & 5755 ~ 5795MHz
Number of Channel	5190 ~ 5230MHz: 2 5270 ~ 5310MHz: 2 5510 ~ 5670MHz: 3 5755 ~ 5795MHz: 2
Output Power	5190 ~ 5230MHz: 79.230mW 5270 ~ 5310MHz: 76.296mW 5510 ~ 5670MHz: 75.531mW 5755 ~ 5795MHz: 83.853mW
Antenna Type	Printed antenna with 4.0dBi gain (TX) Printed antenna with 6.2dBi gain (RX)
Antenna Connector	N/A
Accessory Device	Adapter, Remote control (Brand: ZINWELL, Model: JX-9051)
Data Cable Supplied	1.55m shielded HDMI cable with 2 cores; 1.45m shielded IR out cable without core; 1m shielded USB cable with 1 core (used for adapter 2 & 5)

Note:

- This report is prepared for FCC class II permissive change. This report is issued as a supplementary report to BV ADT report no. RF110607C09R & RF110607C09R-1. The differences compared with the original report are listed below:
  - Updating standard to new rule version for all bands.
  - Adding new adapters (adapter 4 & 5).
  - Changing color.
  - Updating remote controller's brand & model.
  - Changing IR cable.
  - Removing brand: GEFEN, Model: EXT-WHD-1080P-LRS.

Therefore, all test items are re-tested in this report.
- The EUT incorporates a MIMO function. Physically, the EUT provides 4 completed transmitters and 4 receivers.

Modulation Mode	TX Function	Support
WHDI (40MHz)	4TX	Nss=4

3. The EUT consumes power from the following adapters. (Adapter 4 & 5 are new adapters)

Adapter 1	
Brand	SINO-AMERICAN
Model	SA110C-05S-A
Input Power	100-240Vac, 50-60Hz, 0.3A
Output Power	5Vdc, 2A, 10W
Power Line	1.5m shielded cable with 1 core

Adapter 2	
Brand	Asian Power Devices Inc.
Model	WA-10K05R
Input Power	100-240Vac, 50-60Hz, 0.3A Max.
Output Power	5Vdc, 2A

Adapter 3	
Brand	Asian Power Devices Inc.
Model	WA-10P05FU
Input Power	100-240Vac, 50-60Hz, 0.3A Max.
Output Power	5Vdc, 2A
Power Line	1.5m non-shielded cable with 1 core

Adapter 4	
Brand	Asian Power Devices Inc.
Model	WB-10E05FU
Input Power	100-240Vac, 50-60Hz, 0.4A Max.
Output Power	5Vdc/ 2A
Power Line	1.45m non-shielded cable with 1 core

Adapter 5	
Brand	Asian Power Devices Inc.
Model	WB-10E05R
Input Power	100-240Vac, 50-60Hz, 0.4A Max.
Output Power	5Vdc/ 2A

4. The above EUT information is declared by manufacturer and for more detailed features description, please refer to the manufacturer's specifications or user's manual.



### 3.2 Description of Test Modes

#### FOR 5190 ~ 5230 MHz

2 channels are provided for WHDI (40MHz):

Channel	Frequency	Channel	Frequency
38	5190 MHz	46	5230 MHz

#### FOR 5270 ~ 5310MHz

2 channels are provided for WHDI (40MHz):

Channel	Frequency	Channel	Frequency
54	5270 MHz	62	5310 MHz

#### FOR 5510 ~ 5670MHz

3 channels are provided for WHDI (40MHz):

Channel	Frequency	Channel	Frequency
102	5510 MHz	134	5670 MHz
110	5550 MHz		

#### FOR 5755 ~ 5795MHz

2 channels are provided for WHDI (40MHz):

Channel	Frequency	Channel	Frequency
151	5755MHz	159	5795MHz

### 3.2.1 Test Mode Applicability and Tested Channel Detail

EUT CONFIGURE MODE	APPLICABLE TO				DESCRIPTION
	RE $\geq$ 1G	RE<1G	PLC	APCM	
A	√	√	√	√	Adapter: WA-10P05FU
B	-	√	√	-	Adapter: WB-10E05R

Where **RE $\geq$ 1G**: Radiated Emission above 1GHz & Bandedge Measurement  
**RE<1G**: Radiated Emission below 1GHz  
**PLC**: Power Line Conducted Emission  
**APCM**: Antenna Port Conducted Measurement

**NOTE:**

1. The EUT had been pre-tested on the positioned of each 3 axis. The worst case was found when positioned on **Z-plane**.
2. "-" means no effect.

#### Radiated Emission Test (Above 1GHz):

- Pre-Scan has been conducted to determine the worst-case mode from all possible combinations between available modulations, data rates and antenna ports (if EUT with antenna diversity architecture).
- Following channel(s) was (were) selected for the final test as listed below.

EUT CONFIGURE MODE	MODE	FREQ. BAND (MHz)	AVAILABLE CHANNEL	TESTED CHANNEL	MODULATION TECHNOLOGY	DATA RATE (Mbps)
A	WHDI (40MHz)	5190-5230	38 to 46	38, 46	OFDM	1
A	WHDI (40MHz)	5270-5310	54 to 62	54, 62	OFDM	1
A	WHDI (40MHz)	5510-5670	102 to 134	102, 110, 134	OFDM	1
A	WHDI (40MHz)	5755-5795	151 to 159	151, 159	OFDM	1

#### Radiated Emission Test (Below 1GHz):

- Pre-Scan has been conducted to determine the worst-case mode from all possible combinations between available modulations, data rates and antenna ports (if EUT with antenna diversity architecture).
- Following channel(s) was (were) selected for the final test as listed below.

EUT CONFIGURE MODE	MODE	FREQ. BAND (MHz)	AVAILABLE CHANNEL	TESTED CHANNEL	MODULATION TECHNOLOGY	DATA RATE (Mbps)
A, B	WHDI (40MHz)	5190-5230, 5270-5310, 5510-5670, 5755-5795	38 to 46, 54 to 62, 102 to 134, 151 to 159	159	OFDM	1

**Power Line Conducted Emission Test:**

- Pre-Scan has been conducted to determine the worst-case mode from all possible combinations between available modulations, data rates and antenna ports (if EUT with antenna diversity architecture).
- Following channel(s) was (were) selected for the final test as listed below.

EUT CONFIGURE MODE	MODE	FREQ. BAND (MHz)	AVAILABLE CHANNEL	TESTED CHANNEL	MODULATION TECHNOLOGY	DATA RATE (Mbps)
A, B	WHDI (40MHz)	5190-5230, 5270-5310, 5510-5670, 5755-5795	38 to 46, 54 to 62, 102 to 134, 151 to 159	159	OFDM	1

**Antenna Port Conducted Measurement:**

- This item includes all test value of each mode, but only includes spectrum plot of worst value of each mode.
- Pre-Scan has been conducted to determine the worst-case mode from all possible combinations between available modulations, data rates and antenna ports (if EUT with antenna diversity architecture).
- Following channel(s) was (were) selected for the final test as listed below.

EUT CONFIGURE MODE	MODE	FREQ. BAND (MHz)	AVAILABLE CHANNEL	TESTED CHANNEL	MODULATION TECHNOLOGY	DATA RATE (Mbps)
A	WHDI (40MHz)	5190-5230	38 to 46	38, 46	OFDM	1
A	WHDI (40MHz)	5270-5310	54 to 62	54, 62	OFDM	1
A	WHDI (40MHz)	5510-5670	102 to 134	102, 110, 134	OFDM	1
A	WHDI (40MHz)	5755-5795	151 to 159	151, 159	OFDM	1

**Test Condition:**

APPLICABLE TO	ENVIRONMENTAL CONDITIONS	INPUT POWER	TESTED BY
RE≥1G	25deg. C, 65%RH	120Vac, 60Hz	Tank Wu
RE<1G	25deg. C, 65%RH	120Vac, 60Hz	Tank Wu
PLC	25deg. C, 65%RH	120Vac, 60Hz	Bayu Chen
APCM	25deg. C, 60%RH	120Vac, 60Hz	Antony Lee

### 3.3 Duty Cycle of Test Signal

Duty cycle of test signal is < 98 %, duty factor is required

Duty cycle =  $2.000/2.112 = 0.947$ , Duty factor =  $10 * \log(1/0.947) = 0.24$

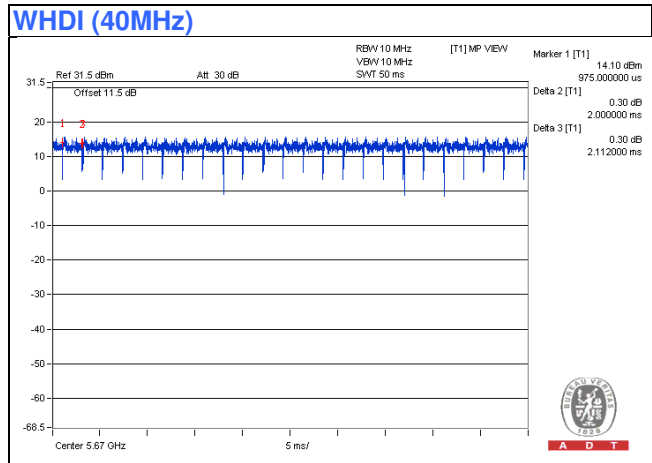

### 3.4 Description of Support Units

The EUT has been tested as an independent unit together with other necessary accessories or support units. The following support units or accessories were used to form a representative test configuration during the tests.

ID	Product	Brand	Model No.	Serial No.	FCC ID	Remarks
A.	TV Monitor	SONY	KDL-32EX650	4365185	Verification	-
B.	DVD Player	SONY	DVP-NS975V	2030314	Verification	-
C.	DVD Player	SONY	DVP-NS975V	2030869	Verification	-

Note: All power cords of the above support units are non-shielded (1.8m).

ID	Descriptions	Qty.	Length (m)	Shielding (Yes/No)	Cores (Qty.)	Remarks
1.	HDMI cable	1	1.55	Y	2	Accessory of EUT
2.	HDMI cable	1	1.8	Y	1	-
3.	HDMI cable	1	1.8	Y	1	-
4.	IR cable	1	1.45	Y	0	Accessory of EUT
5.	DC cable	1	1.45	Y	1	Attached on adapter 4
6.	USB cable	1	1	Y	1	Accessory of EUT For adapter 5

Note: The core(s) is(are) originally attached to the cable(s).



### 3.5 General Description of Applied Standards

The EUT is a RF Product. According to the specifications of the manufacturer, it must comply with the requirements of the following standards:

**FCC Part 15, Subpart E (15.407)**

**789033 D02 General UNII Test Procedure New Rules v01r02**

**662911 D01 Multiple Transmitter Output v02r01**

ANSI C63.10-2013

All test items have been performed and recorded as per the above standards.

**Note:** The EUT is also considered as a kind of computer peripheral, because the connection to computer is necessary for typical use. It has been verified to comply with the requirements of FCC Part 15, Subpart B, Class B (DoC). The test report has been issued separately.

## 4 Test Types and Results

### 4.1 Radiated Emission and Bandedge Measurement

#### 4.1.1 Limits of Radiated Emission and Bandedge Measurement

Radiated emissions which fall in the restricted bands must comply with the radiated emission limits specified as below table.

Frequencies (MHz)	Field Strength (microvolts/meter)	Measurement Distance (meters)
0.009 ~ 0.490	2400/F(kHz)	300
0.490 ~ 1.705	24000/F(kHz)	30
1.705 ~ 30.0	30	30
30 ~ 88	100	3
88 ~ 216	150	3
216 ~ 960	200	3
Above 960	500	3

#### NOTE:

1. The lower limit shall apply at the transition frequencies.
2. Emission level (dBuV/m) = 20 log Emission level (uV/m).
3. For frequencies above 1000MHz, the field strength limits are based on average detector, however, the peak field strength of any emission shall not exceed the maximum permitted average limits, specified above by more than 20dB under any condition of modulation.

#### Limits of Unwanted Emission out of the Restricted Bands

Applicable to	Limit	
789033 D02 General UNII Test Procedure New Rules v01r02	FIELD STRENGTH AT 3m	
	PK:74 (dBµV/m)	AV:54 (dBµV/m)
Applicable to	EIRP Limit	Equivalent Field Strength at 3m
15.407(b)(1)	PK:-27 (dBm/MHz)	PK:68.2(dBµV/m)
15.407(b)(2)		
15.407(b)(3)		
15.407(b)(4)	PK:-27 (dBm/MHz) <sup>*1</sup> PK:-17 (dBm/MHz) <sup>*2</sup>	PK: 68.2(dBµV/m) <sup>*1</sup> PK:78.2 (dBµV/m) <sup>*2</sup>

**NOTE:** <sup>\*1</sup> beyond 10MHz of the band edge <sup>\*2</sup> within 10 MHz of band edge

The following formula is used to convert the equipment isotropic radiated power (eirp) to field strength:

$$E = \frac{1000000\sqrt{30P}}{3} \mu\text{V/m, where P is the eirp (Watts).}$$



#### 4.1.2 Test Instruments

Test date: Nov. 30 ~ Dec. 11, 2015 (All tests except radiated emission below 1GHz test)

Description & Manufacturer	Model No.	Serial No.	Cal. Date	Cal. Due
Test Receiver ROHDE & SCHWARZ	ESCI	100424	Oct. 12, 2015	Oct. 11, 2016
Spectrum Analyzer ROHDE & SCHWARZ	FSP40	100269	Mar. 30, 2015	Mar. 29, 2016
BILOG Antenna SCHWARZBECK	VULB9168	9168-148	Feb. 02, 2015	Feb. 01, 2016
HORN Antenna SCHWARZBECK	BBHA 9120 D	9120D-1169	Feb. 09, 2015	Feb. 08, 2016
HORN Antenna SCHWARZBECK	BBHA 9170	BBHA9170241	Feb. 09, 2015	Feb. 08, 2016
Preamplifier Agilent	8449B	3008A01911	Aug. 09, 2015	Aug. 08, 2016
Preamplifier Agilent	8447D	2944A10638	Aug. 09, 2015	Aug. 08, 2016
RF signal cable HUBER+SUHNER	SUCOFLEX 104	CABLE-CH9-02(309222 +248780)	Aug. 09, 2015	Aug. 08, 2016
RF signal cable HUBER+SUHNER	SUCOFLEX 104	CABLE-CH9-03(274092)	Aug. 09, 2015	Aug. 08, 2016
RF signal cable Woken	8D-FB	Cable-CH9-01	Aug. 11, 2015	Aug. 10, 2016
Software BV ADT	ADT_Radiated_ V7.6.15.9.4	NA	NA	NA
Antenna Tower EMCO	2070/2080	512.835.4684	NA	NA
Turn Table EMCO	2087-2.03	NA	NA	NA
Antenna Tower & Turn BV ADT	AT100	AT93021705	NA	NA
Turn Table BV ADT	TT100	TT93021705	NA	NA
Turn Table Controller BV ADT	SC100	SC93021705	NA	NA
26GHz ~ 40GHz Amplifier	EM26400	815221	Oct. 18, 2015	Oct. 17, 2016
High Speed Peak Power Meter	ML2495A	0824011	Jul. 09, 2015	Jul. 08, 2016
Power Sensor	MA2411B	0738171	Jul. 09, 2015	Jul. 08, 2016
WIT Standard Temperature And Humidity Chamber	TH-4S-C	W981030	Jun. 08, 2015	Jun. 07, 2016

- Note:
1. The calibration interval of the above test instruments is 12 months and the calibrations are traceable to NML/ROC and NIST/USA.
  2. The test was performed in HwaYa Chamber 9.
  3. The horn antenna and preamplifier (model: 8449B) are used only for the measurement of emission frequency above 1GHz if tested.
  4. The FCC Site Registration No. is 215374.
  5. The IC Site Registration No. is IC 7450F-9.



Test date: Jun. 02, 2016 (Radiated emission below 1GHz test)

Description & Manufacturer	Model No.	Serial No.	Cal. Date	Cal. Due
Test Receiver ROHDE & SCHWARZ	ESCS30	100289	Dec. 23, 2015	Dec. 22, 2016
Spectrum Analyzer ROHDE & SCHWARZ	FSP40	100269	Apr. 19, 2016	Apr. 18, 2017
BILOG Antenna SCHWARZBECK	VULB9168	9168-148	Jan. 18, 2016	Jan. 17, 2017
HORN Antenna SCHWARZBECK	BBHA 9120 D	9120D-1169	Jan. 08, 2016	Jan. 07, 2017
HORN Antenna SCHWARZBECK	BBHA 9170	BBHA9170241	Jan. 18, 2016	Jan. 17, 2017
Preamplifier Agilent	8449B	3008A01911	Aug. 09, 2015	Aug. 08, 2016
Preamplifier Agilent	8447D	2944A10638	Aug. 09, 2015	Aug. 08, 2016
RF signal cable HUBER+SUHNER	SUCOFLEX 104	CABLE-CH9-02(309222 +248780)	Aug. 09, 2015	Aug. 08, 2016
RF signal cable HUBER+SUHNER	SUCOFLEX 104	CABLE-CH9-03(274092 )	Aug. 09, 2015	Aug. 08, 2016
RF signal cable Woken	8D-FB	Cable-CH9-01	Aug. 11, 2015	Aug. 10, 2016
Software BV ADT	ADT_Radiated_ V7.6.15.9.4	NA	NA	NA
Antenna Tower EMCO	2070/2080	512.835.4684	NA	NA
Turn Table EMCO	2087-2.03	NA	NA	NA
Antenna Tower & Turn BV ADT	AT100	AT93021705	NA	NA
Turn Table BV ADT	TT100	TT93021705	NA	NA
Turn Table Controller BV ADT	SC100	SC93021705	NA	NA

- Note: 1. The calibration interval of the above test instruments is 12 months and the calibrations are traceable to NML/ROC and NIST/USA.  
2. The test was performed in HwaYa Chamber 9.  
3. The horn antenna and preamplifier (model: 8449B) are used only for the measurement of emission frequency above 1GHz if tested.  
4. The FCC Site Registration No. is 215374.  
5. The IC Site Registration No. is IC 7450F-9.

#### 4.1.3 Test Procedures

- a. The EUT was placed on the top of a rotating table 0.8 meters (for below 1GHz) / 1.5 meters (for above 1GHz) above the ground at 3 meter chamber room for test. The table was rotated 360 degrees to determine the position of the highest radiation.
- b. The EUT was set 3 meters away from the interference-receiving antenna, which was mounted on the top of a variable-height antenna tower.
- c. The height of antenna is varied from one meter to four meters above the ground to determine the maximum value of the field strength. Both horizontal and vertical polarizations of the antenna are set to make the measurement.
- d. For each suspected emission, the EUT was arranged to its worst case and then the antenna was tuned to heights from 1 meter to 4 meters and the rotatable table was turned from 0 degrees to 360 degrees to find the maximum reading.
- e. The test-receiver system was set to quasi-peak detect function and specified bandwidth with maximum hold mode when the test frequency is below 1 GHz.
- f. The test-receiver system was set to peak and average detect function and specified bandwidth with maximum hold mode when the test frequency is above 1 GHz. If the peak reading value also meets average limit, measurement with the average detector is unnecessary.

**Note:**

1. The resolution bandwidth and video bandwidth of test receiver/spectrum analyzer is 120kHz for Quasi-peak detection (QP) at frequency below 1GHz.
2. The resolution bandwidth of test receiver/spectrum analyzer is 1 MHz and the video bandwidth is 3 MHz for Peak detection (PK) at frequency above 1GHz.
3. The resolution bandwidth of test receiver/spectrum analyzer is 1MHz and the video bandwidth is 3MHz for RMS Average (Duty cycle < 98%) for Average detection (AV) at frequency above 1GHz, then the measurement results was added to a correction factor ( $10 \log(1/\text{duty cycle})$ ).
4. The resolution bandwidth of test receiver/spectrum analyzer is 1MHz and the video bandwidth is 10Hz (Duty cycle  $\geq 98\%$ ) for Average detection (AV) at frequency above 1GHz.
5. All modes of operation were investigated and the worst-case emissions are reported.

#### 4.1.4 Deviation from Test Standard

No deviation.

#### 4.1.5 Test Set Up

##### <Frequency Range below 1GHz>

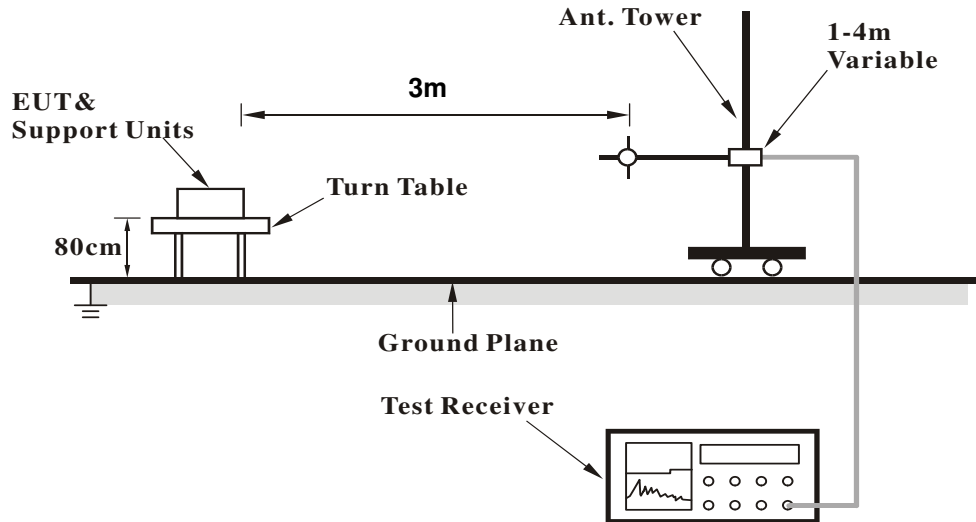

##### <Frequency Range above 1GHz>

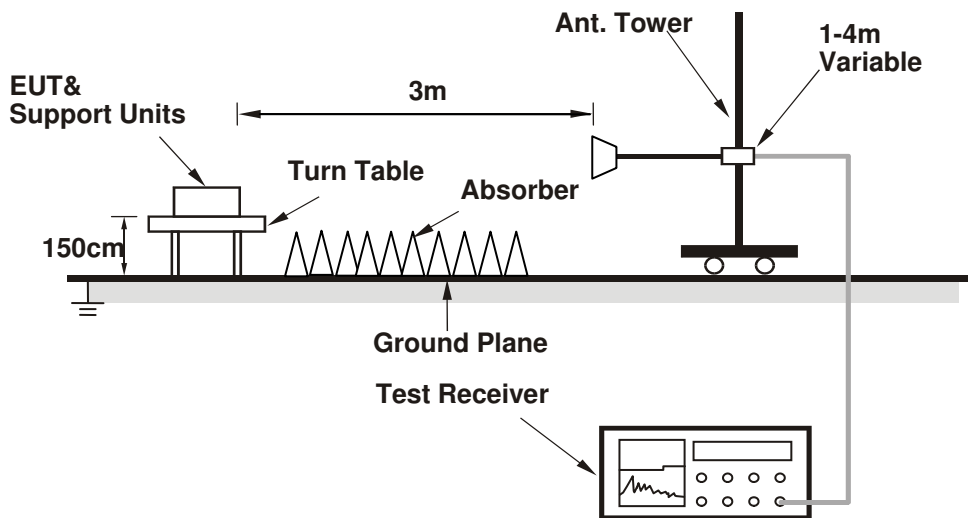

For the actual test configuration, please refer to the attached file (Test Setup Photo)

#### 4.1.6 EUT Operating Conditions

- Placed the EUT on the testing table.
- The EUT was connected the DVD player on test table & LCD monitor via HDMI cables.
- The EUT under transmission condition continuously at specific channel frequency.

#### 4.1.7 Test Results

##### Above 1GHz Data

CHANNEL	TX Channel 38	DETECTOR FUNCTION	Peak (PK)
FREQUENCY RANGE	1GHz ~ 40GHz		Average (AV)

##### ANTENNA POLARITY & TEST DISTANCE: HORIZONTAL AT 3 M

NO.	FREQ. (MHz)	EMISSION LEVEL (dBuV/m)	LIMIT (dBuV/m)	MARGIN (dB)	ANTENNA HEIGHT (m)	TABLE ANGLE (Degree)	RAW VALUE (dBuV)	CORRECTION FACTOR (dB/m)
1	5150.00	59.9 PK	74.0	-14.1	1.55 H	41	56.00	3.90
2	5150.00	45.9 AV	54.0	-8.1	1.55 H	41	42.00	3.90
3	*5190.00	103.1 PK			1.28 H	77	61.60	41.50
4	*5190.00	90.5 AV			1.28 H	77	49.00	41.50
5	#10380.00	62.6 PK	68.2	-5.6	2.66 H	77	47.20	15.40

##### ANTENNA POLARITY & TEST DISTANCE: VERTICAL AT 3 M

NO.	FREQ. (MHz)	EMISSION LEVEL (dBuV/m)	LIMIT (dBuV/m)	MARGIN (dB)	ANTENNA HEIGHT (m)	TABLE ANGLE (Degree)	RAW VALUE (dBuV)	CORRECTION FACTOR (dB/m)
1	5150.00	60.2 PK	74.0	-13.8	1.97 V	123	56.30	3.90
2	5150.00	46.1 AV	54.0	-7.9	1.97 V	123	42.20	3.90
3	*5190.00	104.5 PK			1.76 V	202	63.00	41.50
4	*5190.00	91.4 AV			1.76 V	202	49.90	41.50
5	#10380.00	61.5 PK	68.2	-6.7	1.26 V	351	46.10	15.40

##### Remark:

1. Emission Level(dBuV/m) = Raw Value(dBuV) + Correction Factor(dB/m)
2. Correction Factor(dB/m) = Antenna Factor(dB/m) + Cable Factor(dB)
3. The other emission levels were very low against the limit.
4. Margin value = Emission Level – Limit value
5. " \* ": Fundamental frequency.
6. " # ": The radiated frequency is out of the restricted band.

CHANNEL	TX Channel 46	DETECTOR FUNCTION	Peak (PK)
FREQUENCY RANGE	1GHz ~ 40GHz		Average (AV)

**ANTENNA POLARITY & TEST DISTANCE: HORIZONTAL AT 3 M**

NO.	FREQ. (MHz)	EMISSION LEVEL (dBuV/m)	LIMIT (dBuV/m)	MARGIN (dB)	ANTENNA HEIGHT (m)	TABLE ANGLE (Degree)	RAW VALUE (dBuV)	CORRECTION FACTOR (dB/m)
1	*5230.00	104.1 PK			1.79 H	80	62.50	41.60
2	*5230.00	90.6 AV			1.79 H	80	49.00	41.60
3	5350.00	59.8 PK	74.0	-14.2	1.40 H	212	55.80	4.00
4	5350.00	46.0 AV	54.0	-8.0	1.40 H	212	42.00	4.00
5	#10460.00	63.0 PK	68.2	-5.2	2.42 H	81	47.50	15.50

**ANTENNA POLARITY & TEST DISTANCE: VERTICAL AT 3 M**

NO.	FREQ. (MHz)	EMISSION LEVEL (dBuV/m)	LIMIT (dBuV/m)	MARGIN (dB)	ANTENNA HEIGHT (m)	TABLE ANGLE (Degree)	RAW VALUE (dBuV)	CORRECTION FACTOR (dB/m)
1	*5230.00	104.2 PK			1.00 V	199	62.60	41.60
2	*5230.00	91.8 AV			1.00 V	199	50.20	41.60
3	5350.00	59.8 PK	74.0	-14.2	1.70 V	149	55.80	4.00
4	5350.00	46.7 AV	54.0	-7.3	1.70 V	149	42.70	4.00
5	#10460.00	61.0 PK	68.2	-7.2	1.02 V	350	45.50	15.50

**Remark:**

1. Emission Level(dBuV/m) = Raw Value(dBuV) + Correction Factor(dB/m)
2. Correction Factor(dB/m) = Antenna Factor(dB/m) + Cable Factor(dB)
3. The other emission levels were very low against the limit.
4. Margin value = Emission Level – Limit value
5. " \* ": Fundamental frequency.
6. " # ": The radiated frequency is out of the restricted band.

CHANNEL	TX Channel 54	DETECTOR FUNCTION	Peak (PK)
FREQUENCY RANGE	1GHz ~ 40GHz		Average (AV)

ANTENNA POLARITY & TEST DISTANCE: HORIZONTAL AT 3 M								
NO.	FREQ. (MHz)	EMISSION LEVEL (dBuV/m)	LIMIT (dBuV/m)	MARGIN (dB)	ANTENNA HEIGHT (m)	TABLE ANGLE (Degree)	RAW VALUE (dBuV)	CORRECTION FACTOR (dB/m)
1	5150.00	59.5 PK	74.0	-14.5	1.49 H	308	55.60	3.90
2	5150.00	46.3 AV	54.0	-7.7	1.49 H	308	42.40	3.90
3	*5270.00	105.3 PK			1.01 H	74	63.60	41.70
4	*5270.00	92.1 AV			1.01 H	74	50.40	41.70
5	#10540.00	63.1 PK	68.2	-5.1	2.28 H	78	47.30	15.80

ANTENNA POLARITY & TEST DISTANCE: VERTICAL AT 3 M								
NO.	FREQ. (MHz)	EMISSION LEVEL (dBuV/m)	LIMIT (dBuV/m)	MARGIN (dB)	ANTENNA HEIGHT (m)	TABLE ANGLE (Degree)	RAW VALUE (dBuV)	CORRECTION FACTOR (dB/m)
1	5150.00	59.8 PK	74.0	-14.2	1.77 V	131	55.90	3.90
2	5150.00	46.4 AV	54.0	-7.6	1.77 V	131	42.50	3.90
3	*5270.00	104.7 PK			1.71 V	191	63.00	41.70
4	*5270.00	91.4 AV			1.71 V	191	49.70	41.70
5	#10540.00	61.2 PK	68.2	-7.0	1.12 V	347	45.40	15.80

Remark:

1. Emission Level(dBuV/m) = Raw Value(dBuV) + Correction Factor(dB/m)
2. Correction Factor(dB/m) = Antenna Factor(dB/m) + Cable Factor(dB)
3. The other emission levels were very low against the limit.
4. Margin value = Emission Level – Limit value
5. " \* ": Fundamental frequency.
6. " # ": The radiated frequency is out of the restricted band.

CHANNEL	TX Channel 62	DETECTOR FUNCTION	Peak (PK)
FREQUENCY RANGE	1GHz ~ 40GHz		Average (AV)

**ANTENNA POLARITY & TEST DISTANCE: HORIZONTAL AT 3 M**

NO.	FREQ. (MHz)	EMISSION LEVEL (dBuV/m)	LIMIT (dBuV/m)	MARGIN (dB)	ANTENNA HEIGHT (m)	TABLE ANGLE (Degree)	RAW VALUE (dBuV)	CORRECTION FACTOR (dB/m)
1	*5310.00	105.0 PK			1.00 H	179	63.30	41.70
2	*5310.00	91.3 AV			1.00 H	179	49.60	41.70
3	5350.00	60.5 PK	74.0	-13.5	1.44 H	310	56.50	4.00
4	5350.00	46.0 AV	54.0	-8.0	1.44 H	310	42.00	4.00
5	10620.00	62.0 PK	74.0	-12.0	2.43 H	77	46.10	15.90
6	10620.00	52.8 AV	54.0	-1.2	2.43 H	77	36.90	15.90

**ANTENNA POLARITY & TEST DISTANCE: VERTICAL AT 3 M**

NO.	FREQ. (MHz)	EMISSION LEVEL (dBuV/m)	LIMIT (dBuV/m)	MARGIN (dB)	ANTENNA HEIGHT (m)	TABLE ANGLE (Degree)	RAW VALUE (dBuV)	CORRECTION FACTOR (dB/m)
1	*5310.00	104.9 PK			1.71 V	191	63.20	41.70
2	*5310.00	91.4 AV			1.71 V	191	49.70	41.70
3	5350.00	62.8 PK	74.0	-11.2	1.69 V	271	58.80	4.00
4	5350.00	45.7 AV	54.0	-8.3	1.69 V	271	41.70	4.00
5	10620.00	61.8 PK	74.0	-12.2	1.00 V	348	45.90	15.90
6	10620.00	48.7 AV	54.0	-5.3	1.00 V	348	32.80	15.90

**Remark:**

1. Emission Level(dBuV/m) = Raw Value(dBuV) + Correction Factor(dB/m)
2. Correction Factor(dB/m) = Antenna Factor(dB/m) + Cable Factor(dB)
3. The other emission levels were very low against the limit.
4. Margin value = Emission Level – Limit value
5. " \* ": Fundamental frequency.



CHANNEL	TX Channel 102	DETECTOR FUNCTION	Peak (PK)
FREQUENCY RANGE	1GHz ~ 40GHz		Average (AV)

**ANTENNA POLARITY & TEST DISTANCE: HORIZONTAL AT 3 M**

NO.	FREQ. (MHz)	EMISSION LEVEL (dBuV/m)	LIMIT (dBuV/m)	MARGIN (dB)	ANTENNA HEIGHT (m)	TABLE ANGLE (Degree)	RAW VALUE (dBuV)	CORRECTION FACTOR (dB/m)
1	5460.00	58.9 PK	74.0	-15.1	1.30 H	291	55.00	3.90
2	5460.00	46.2 AV	54.0	-7.8	1.30 H	291	42.30	3.90
3	#5470.00	63.3 PK	74.0	-10.7	1.32 H	293	59.40	3.90
4	#5470.00	47.3 AV	54.0	-6.7	1.32 H	293	43.40	3.90
5	*5510.00	106.5 PK			1.00 H	76	64.90	41.60
6	*5510.00	92.6 AV			1.00 H	76	51.00	41.60
7	11020.00	62.6 PK	74.0	-11.4	2.43 H	77	45.70	16.90
<b>8</b>	<b>11020.00</b>	<b>53.1 AV</b>	<b>54.0</b>	<b>-0.9</b>	<b>2.43 H</b>	<b>77</b>	<b>36.20</b>	<b>16.90</b>

**ANTENNA POLARITY & TEST DISTANCE: VERTICAL AT 3 M**

NO.	FREQ. (MHz)	EMISSION LEVEL (dBuV/m)	LIMIT (dBuV/m)	MARGIN (dB)	ANTENNA HEIGHT (m)	TABLE ANGLE (Degree)	RAW VALUE (dBuV)	CORRECTION FACTOR (dB/m)
1	5460.00	59.5 PK	74.0	-14.5	1.73 V	177	55.60	3.90
2	5460.00	46.1 AV	54.0	-7.9	1.73 V	177	42.20	3.90
3	#5470.00	66.3 PK	74.0	-7.7	1.70 V	185	62.40	3.90
4	#5470.00	47.9 AV	54.0	-6.1	1.70 V	185	44.00	3.90
5	*5510.00	105.7 PK			1.90 V	188	64.10	41.60
6	*5510.00	92.1 AV			1.90 V	188	50.50	41.60
7	11020.00	62.6 PK	74.0	-11.4	1.13 V	333	45.70	16.90
8	11020.00	49.4 AV	54.0	-4.6	1.13 V	333	32.50	16.90

**Remark:**

1. Emission Level(dBuV/m) = Raw Value(dBuV) + Correction Factor(dB/m)
2. Correction Factor(dB/m) = Antenna Factor(dB/m) + Cable Factor(dB)
3. The other emission levels were very low against the limit.
4. Margin value = Emission Level – Limit value
5. " \* ": Fundamental frequency.
6. " # ": The radiated frequency is out of the restricted band.

CHANNEL	TX Channel 110	DETECTOR FUNCTION	Peak (PK)
FREQUENCY RANGE	1GHz ~ 40GHz		Average (AV)

**ANTENNA POLARITY & TEST DISTANCE: HORIZONTAL AT 3 M**

NO.	FREQ. (MHz)	EMISSION LEVEL (dBuV/m)	LIMIT (dBuV/m)	MARGIN (dB)	ANTENNA HEIGHT (m)	TABLE ANGLE (Degree)	RAW VALUE (dBuV)	CORRECTION FACTOR (dB/m)
1	*5550.00	105.2 PK			1.00 H	75	63.50	41.70
2	*5550.00	91.9 AV			1.00 H	75	50.20	41.70
3	11100.00	61.6 PK	74.0	-12.4	2.48 H	77	45.80	15.80
4	11100.00	51.6 AV	54.0	-2.4	2.48 H	77	35.80	15.80

**ANTENNA POLARITY & TEST DISTANCE: VERTICAL AT 3 M**

NO.	FREQ. (MHz)	EMISSION LEVEL (dBuV/m)	LIMIT (dBuV/m)	MARGIN (dB)	ANTENNA HEIGHT (m)	TABLE ANGLE (Degree)	RAW VALUE (dBuV)	CORRECTION FACTOR (dB/m)
1	*5550.00	104.6 PK			1.87 V	170	62.90	41.70
2	*5550.00	91.3 AV			1.87 V	170	49.60	41.70
3	11100.00	61.1 PK	74.0	-12.9	1.20 V	316	45.30	15.80
4	11100.00	48.5 AV	54.0	-5.5	1.20 V	316	32.70	15.80

**Remark:**

1. Emission Level(dBuV/m) = Raw Value(dBuV) + Correction Factor(dB/m)
2. Correction Factor(dB/m) = Antenna Factor(dB/m) + Cable Factor(dB)
3. The other emission levels were very low against the limit.
4. Margin value = Emission Level – Limit value
5. " \* ": Fundamental frequency.

CHANNEL	TX Channel 134	DETECTOR FUNCTION	Peak (PK)
FREQUENCY RANGE	1GHz ~ 40GHz		Average (AV)

**ANTENNA POLARITY & TEST DISTANCE: HORIZONTAL AT 3 M**

NO.	FREQ. (MHz)	EMISSION LEVEL (dBuV/m)	LIMIT (dBuV/m)	MARGIN (dB)	ANTENNA HEIGHT (m)	TABLE ANGLE (Degree)	RAW VALUE (dBuV)	CORRECTION FACTOR (dB/m)
1	*5670.00	105.2 PK			1.00 H	77	63.20	42.00
2	*5670.00	91.0 AV			1.00 H	77	49.00	42.00
3	#5850.00	59.2 PK	74.0	-14.8	1.50 H	262	54.50	4.70
4	#5850.00	45.2 AV	54.0	-8.8	1.50 H	262	40.50	4.70
5	11340.00	62.1 PK	74.0	-11.9	2.51 H	76	45.30	16.80
6	11340.00	51.1 AV	54.0	-2.9	2.51 H	76	34.30	16.80

**ANTENNA POLARITY & TEST DISTANCE: VERTICAL AT 3 M**

NO.	FREQ. (MHz)	EMISSION LEVEL (dBuV/m)	LIMIT (dBuV/m)	MARGIN (dB)	ANTENNA HEIGHT (m)	TABLE ANGLE (Degree)	RAW VALUE (dBuV)	CORRECTION FACTOR (dB/m)
1	*5670.00	104.3 PK			2.37 V	86	62.30	42.00
2	*5670.00	91.6 AV			2.37 V	86	49.60	42.00
3	#5850.00	58.8 PK	74.0	-15.2	1.90 V	177	54.10	4.70
4	#5850.00	45.4 AV	54.0	-8.6	1.90 V	177	40.70	4.70
5	11340.00	61.7 PK	74.0	-12.3	1.20 V	311	44.90	16.80
6	11340.00	48.7 AV	54.0	-5.3	1.20 V	311	31.90	16.80

**Remark:**

1. Emission Level(dBuV/m) = Raw Value(dBuV) + Correction Factor(dB/m)
2. Correction Factor(dB/m) = Antenna Factor(dB/m) + Cable Factor(dB)
3. The other emission levels were very low against the limit.
4. Margin value = Emission Level – Limit value
5. " \* ": Fundamental frequency.
6. " # ": The radiated frequency is out of the restricted band.

CHANNEL	TX Channel 151	DETECTOR FUNCTION	Peak (PK)
FREQUENCY RANGE	1GHz ~ 40GHz		Average (AV)

**ANTENNA POLARITY & TEST DISTANCE: HORIZONTAL AT 3 M**

NO.	FREQ. (MHz)	EMISSION LEVEL (dBuV/m)	LIMIT (dBuV/m)	MARGIN (dB)	ANTENNA HEIGHT (m)	TABLE ANGLE (Degree)	RAW VALUE (dBuV)	CORRECTION FACTOR (dB/m)
1	#5714.90	59.9 PK	74.0	-14.1	1.98 H	77	55.50	4.40
2	#5714.90	45.7 AV	54.0	-8.3	1.98 H	77	41.30	4.40
3	#5722.90	61.7 PK	78.2	-16.5	1.95 H	75	57.30	4.40
4	#5725.00	49.3 PK	78.2	-28.9	1.95 H	75	44.90	4.40
5	*5755.00	104.6 PK			1.07 H	77	62.40	42.20
6	*5755.00	91.5 AV			1.07 H	77	49.30	42.20
7	11510.00	61.9 PK	74.0	-12.1	1.90 H	100	46.70	15.20
8	11510.00	50.6 AV	54.0	-3.4	1.90 H	100	35.40	15.20

**ANTENNA POLARITY & TEST DISTANCE: VERTICAL AT 3 M**

NO.	FREQ. (MHz)	EMISSION LEVEL (dBuV/m)	LIMIT (dBuV/m)	MARGIN (dB)	ANTENNA HEIGHT (m)	TABLE ANGLE (Degree)	RAW VALUE (dBuV)	CORRECTION FACTOR (dB/m)
1	#5714.90	59.6 PK	74.0	-14.4	1.71 V	155	55.20	4.40
2	#5714.90	45.6 AV	54.0	-8.4	1.71 V	155	41.20	4.40
3	#5722.90	60.9 PK	78.2	-17.3	1.80 V	133	56.50	4.40
4	#5725.00	48.7 PK	78.2	-29.5	1.71 V	153	44.30	4.40
5	*5755.00	103.6 PK			1.73 V	195	61.40	42.20
6	*5755.00	90.4 AV			1.73 V	195	48.20	42.20
7	11510.00	60.5 PK	74.0	-13.5	1.18 V	332	45.30	15.20
8	11510.00	47.9 AV	54.0	-6.1	1.18 V	332	32.70	15.20

**Remark:**

1. Emission Level(dBuV/m) = Raw Value(dBuV) + Correction Factor(dB/m)
2. Correction Factor(dB/m) = Antenna Factor(dB/m) + Cable Factor(dB)
3. The other emission levels were very low against the limit.
4. Margin value = Emission Level – Limit value
5. " \* ": Fundamental frequency.
6. " # ": The radiated frequency is out of the restricted band.

CHANNEL	TX Channel 159	DETECTOR FUNCTION	Peak (PK)
FREQUENCY RANGE	1GHz ~ 40GHz		Average (AV)

**ANTENNA POLARITY & TEST DISTANCE: HORIZONTAL AT 3 M**

NO.	FREQ. (MHz)	EMISSION LEVEL (dBuV/m)	LIMIT (dBuV/m)	MARGIN (dB)	ANTENNA HEIGHT (m)	TABLE ANGLE (Degree)	RAW VALUE (dBuV)	CORRECTION FACTOR (dB/m)
1	*5795.00	104.9 PK			1.16 H	78	62.60	42.30
2	*5795.00	91.8 AV			1.16 H	78	49.50	42.30
3	#5850.00	48.5 PK	78.2	-29.7	1.88 H	322	43.80	4.70
4	#5852.10	60.6 PK	78.2	-17.6	1.79 H	300	55.90	4.70
5	#5860.10	60.4 PK	74.0	-13.6	1.88 H	305	55.70	4.70
6	#5860.10	46.2 AV	54.0	-7.8	1.88 H	305	41.50	4.70
7	11590.00	61.4 PK	74.0	-12.6	1.88 H	49	46.30	15.10
8	11590.00	48.6 AV	54.0	-5.4	1.88 H	49	33.50	15.10

**ANTENNA POLARITY & TEST DISTANCE: VERTICAL AT 3 M**

NO.	FREQ. (MHz)	EMISSION LEVEL (dBuV/m)	LIMIT (dBuV/m)	MARGIN (dB)	ANTENNA HEIGHT (m)	TABLE ANGLE (Degree)	RAW VALUE (dBuV)	CORRECTION FACTOR (dB/m)
1	*5795.00	104.5 PK			2.03 V	162	62.20	42.30
2	*5795.00	90.8 AV			2.03 V	162	48.50	42.30
3	#5850.00	47.9 PK	78.2	-30.3	1.77 V	169	43.20	4.70
4	#5852.10	60.4 PK	78.2	-17.8	1.77 V	180	55.70	4.70
5	#5860.10	60.0 PK	74.0	-14.0	1.79 V	189	55.30	4.70
6	#5860.10	46.3 AV	54.0	-7.7	1.79 V	189	41.60	4.70
7	11590.00	60.7 PK	74.0	-13.3	1.32 V	344	45.60	15.10
8	11590.00	47.8 AV	54.0	-6.2	1.32 V	344	32.70	15.10

**Remark:**

1. Emission Level(dBuV/m) = Raw Value(dBuV) + Correction Factor(dB/m)
2. Correction Factor(dB/m) = Antenna Factor(dB/m) + Cable Factor(dB)
3. The other emission levels were very low against the limit.
4. Margin value = Emission Level – Limit value
5. " \* ": Fundamental frequency.
6. " # ": The radiated frequency is out of the restricted band.

**Below 1GHz worst-case data:**

CHANNEL	TX Channel 159	DETECTOR FUNCTION	Quasi-Peak (QP)
FREQUENCY RANGE	30MHz ~ 1GHz	TEST MODE	A

**ANTENNA POLARITY & TEST DISTANCE: HORIZONTAL AT 3 M**

NO.	FREQ. (MHz)	EMISSION LEVEL (dBuV/m)	LIMIT (dBuV/m)	MARGIN (dB)	ANTENNA HEIGHT (m)	TABLE ANGLE (Degree)	RAW VALUE (dBuV)	CORRECTION FACTOR (dB/m)
1	30.00	26.9 QP	40.0	-13.1	1.50 H	186	42.50	-15.60
2	53.28	26.7 QP	40.0	-13.3	1.50 H	280	40.80	-14.10
3	74.62	21.9 QP	40.0	-18.1	1.24 H	233	38.80	-16.90
4	179.38	22.7 QP	43.5	-20.8	1.24 H	277	37.70	-15.00
5	559.62	30.5 QP	46.0	-15.5	1.99 H	7	38.00	-7.50
6	943.74	35.9 QP	46.0	-10.1	1.99 H	242	36.00	-0.10

**ANTENNA POLARITY & TEST DISTANCE: VERTICAL AT 3 M**

NO.	FREQ. (MHz)	EMISSION LEVEL (dBuV/m)	LIMIT (dBuV/m)	MARGIN (dB)	ANTENNA HEIGHT (m)	TABLE ANGLE (Degree)	RAW VALUE (dBuV)	CORRECTION FACTOR (dB/m)
1	30.00	33.6 QP	40.0	-6.4	1.01 V	212	49.20	-15.60
2	61.04	24.6 QP	40.0	-15.4	1.51 V	285	39.60	-15.00
3	144.46	19.6 QP	43.5	-23.9	1.01 V	38	33.80	-14.20
4	167.74	20.3 QP	43.5	-23.2	1.01 V	8	34.40	-14.10
5	559.62	26.3 QP	46.0	-19.7	1.01 V	53	33.80	-7.50
6	947.62	34.4 QP	46.0	-11.6	2.00 V	354	34.40	0.00

**Remark:**

1. Emission Level(dBuV/m) = Raw Value(dBuV) + Correction Factor(dB/m)
2. Correction Factor(dB/m) = Antenna Factor(dB/m) + Cable Factor(dB)
3. The other emission levels were very low against the limit.
4. Margin value = Emission Level – Limit value

CHANNEL	TX Channel 159	DETECTOR FUNCTION	Quasi-Peak (QP)
FREQUENCY RANGE	30MHz ~ 1GHz	TEST MODE	B

**ANTENNA POLARITY & TEST DISTANCE: HORIZONTAL AT 3 M**

NO.	FREQ. (MHz)	EMISSION LEVEL (dBuV/m)	LIMIT (dBuV/m)	MARGIN (dB)	ANTENNA HEIGHT (m)	TABLE ANGLE (Degree)	RAW VALUE (dBuV)	CORRECTION FACTOR (dB/m)
1	30.00	30.7 QP	40.0	-9.3	1.24 H	0	46.30	-15.60
2	140.58	23.3 QP	43.5	-20.2	2.00 H	104	37.90	-14.60
3	641.10	31.5 QP	46.0	-14.5	1.24 H	35	37.10	-5.60
4	802.12	34.2 QP	46.0	-11.8	1.24 H	6	36.80	-2.60
5	837.04	36.2 QP	46.0	-9.8	2.00 H	195	38.30	-2.10
6	903.00	33.7 QP	46.0	-12.3	1.49 H	112	34.60	-0.90

**ANTENNA POLARITY & TEST DISTANCE: VERTICAL AT 3 M**

NO.	FREQ. (MHz)	EMISSION LEVEL (dBuV/m)	LIMIT (dBuV/m)	MARGIN (dB)	ANTENNA HEIGHT (m)	TABLE ANGLE (Degree)	RAW VALUE (dBuV)	CORRECTION FACTOR (dB/m)
1	31.97	33.4 QP	40.0	-6.6	1.14 V	186	49.30	-15.90
2	55.22	34.8 QP	40.0	-5.2	1.00 V	121	49.00	-14.20
3	70.74	31.2 QP	40.0	-8.8	1.00 V	238	47.30	-16.10
4	128.94	27.0 QP	43.5	-16.5	1.00 V	11	42.60	-15.60
5	559.62	27.1 QP	46.0	-18.9	1.00 V	41	34.60	-7.50
6	837.04	37.3 QP	46.0	-8.7	1.50 V	135	39.40	-2.10

**Remark:**

1. Emission Level(dBuV/m) = Raw Value(dBuV) + Correction Factor(dB/m)
2. Correction Factor(dB/m) = Antenna Factor(dB/m) + Cable Factor(dB)
3. The other emission levels were very low against the limit.
4. Margin value = Emission Level – Limit value

## 4.2 Conducted Emission Measurement

### 4.2.1 Limits of Conducted Emission Measurement

Frequency (MHz)	Conducted Limit (dBuV)	
	Quasi-peak	Average
0.15 - 0.5	66 - 56	56 - 46
0.50 - 5.0	56	46
5.0 - 30.0	60	50

**Note:** 1.



#### 4.2.3 Test Procedures

- a. The EUT was placed 0.4 meters from the conducting wall of the shielded room with EUT being connected to the power mains through a line impedance stabilization network (LISN). Other support units were connected to the power mains through another LISN. The two LISNs provide 50 ohm/ 50uH of coupling impedance for the measuring instrument.
- b. Both lines of the power mains connected to the EUT were checked for maximum conducted interference.
- c. The frequency range from 150kHz to 30MHz was searched. Emission levels under (Limit - 20dB) was not recorded.

**NOTE:** The resolution bandwidth and video bandwidth of test receiver is 9kHz for quasi-peak detection (QP) and average detection (AV) at frequency 0.15MHz-30MHz.

#### 4.2.4 Deviation from Test Standard

No deviation.

#### 4.2.5 Test Setup

### 4.2.7 Test Results

**Worst-case data:**

Phase	Line (L)	Detector Function	Quasi-Peak (QP) / Average (AV)
Channel	TX Channel 159	Test Mode	A

No	Freq. [MHz]	Corr. Factor (dB)	Reading Value [dB (uV)]		Emission Level [dB (uV)]		Limit [dB (uV)]		Margin (dB)	
			Q.P.	AV.	Q.P.	AV.	Q.P.	AV.	Q.P.	AV.
			1	0.18906	9.91	44.33	23.87	54.24	33.78	64.08
2	0.37656	9.93	31.14	10.05	41.07	19.98	58.35	48.35	-17.29	-28.38
3	0.49375	9.94	21.65	4.19	31.59	14.13	56.10	46.10	-24.51	-31.97
4	0.74766	9.97	16.84	3.02	26.81	12.99	56.00	46.00	-29.19	-33.01
5	6.71875	10.28	8.95	-0.23	19.23	10.05	60.00	50.00	-40.77	-39.95
6	8.83984	10.34	8.00	-2.34	18.34	8.00	60.00	50.00	-41.66	-42.00

**Remark:**

1. Q.P. and AV. are abbreviations of quasi-peak and average individually.
2. The emission levels of other frequencies were very low against the limit.
3. Margin value = Emission level - Limit value
4. Correction factor = Insertion loss + Cable loss
5. Emission Level = Correction Factor + Reading Value.

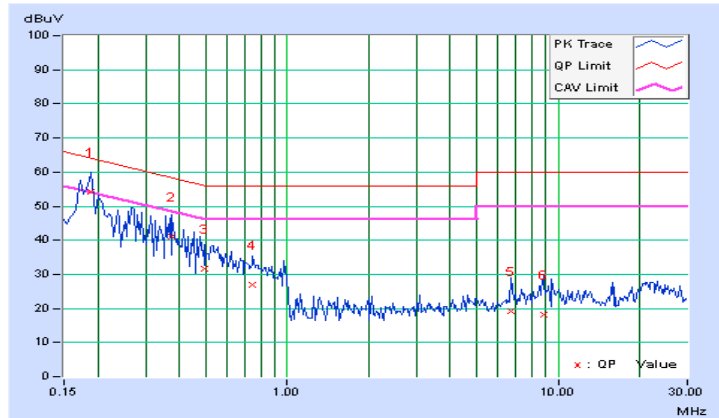

Phase	Neutral (N)	Detector Function	Quasi-Peak (QP) / Average (AV)
Channel	TX Channel 159	Test Mode	A

No	Freq. [MHz]	Corr. Factor (dB)	Reading Value [dB (uV)]		Emission Level [dB (uV)]		Limit [dB (uV)]		Margin (dB)	
			Q.P.	AV.	Q.P.	AV.	Q.P.	AV.	Q.P.	AV.
			1	0.18906	9.92	44.90	22.72	54.82	32.64	64.08
2	0.35703	9.95	31.65	11.57	41.60	21.52	58.80	48.80	-17.20	-27.28
3	0.54453	9.96	24.14	8.03	34.10	17.99	56.00	46.00	-21.90	-28.01
4	0.98594	10.01	13.15	5.36	23.16	15.37	56.00	46.00	-32.84	-30.63
5	9.13281	10.42	7.32	0.23	17.74	10.65	60.00	50.00	-42.26	-39.35
6	25.69141	10.64	11.29	3.78	21.93	14.42	60.00	50.00	-38.07	-35.58

Remark:

1. Q.P. and AV. are abbreviations of quasi-peak and average individually.
2. The emission levels of other frequencies were very low against the limit.
3. Margin value = Emission level - Limit value
4. Correction factor = Insertion loss + Cable loss
5. Emission Level = Correction Factor + Reading Value.

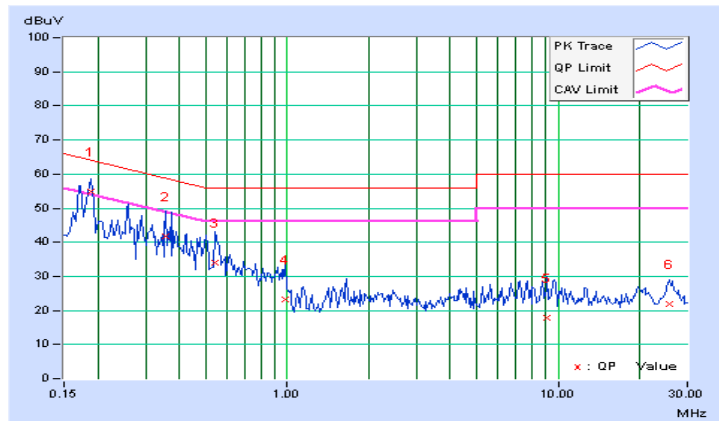

Phase	Line (L)	Detector Function	Quasi-Peak (QP) / Average (AV)
Channel	TX Channel 159	Test Mode	B

No	Freq. [MHz]	Corr. Factor (dB)	Reading Value [dB (uV)]		Emission Level [dB (uV)]		Limit [dB (uV)]		Margin (dB)	
			Q.P.	AV.	Q.P.	AV.	Q.P.	AV.	Q.P.	AV.
			1	0.18516	9.91	46.24	25.77	56.15	35.68	64.25
2	0.37656	9.93	35.72	13.94	45.65	23.87	58.35	48.35	-12.71	-24.49
3	0.57578	9.95	22.87	6.52	32.82	16.47	56.00	46.00	-23.18	-29.53
4	0.70859	9.96	18.86	1.66	28.82	11.62	56.00	46.00	-27.18	-34.38
5	12.32422	10.43	6.63	-1.40	17.06	9.03	60.00	50.00	-42.94	-40.97
6	21.25391	10.59	8.79	-1.52	19.38	9.07	60.00	50.00	-40.62	-40.93

**Remark:**

1. Q.P. and AV. are abbreviations of quasi-peak and average individually.
2. The emission levels of other frequencies were very low against the limit.
3. Margin value = Emission level - Limit value
4. Correction factor = Insertion loss + Cable loss
5. Emission Level = Correction Factor + Reading Value.

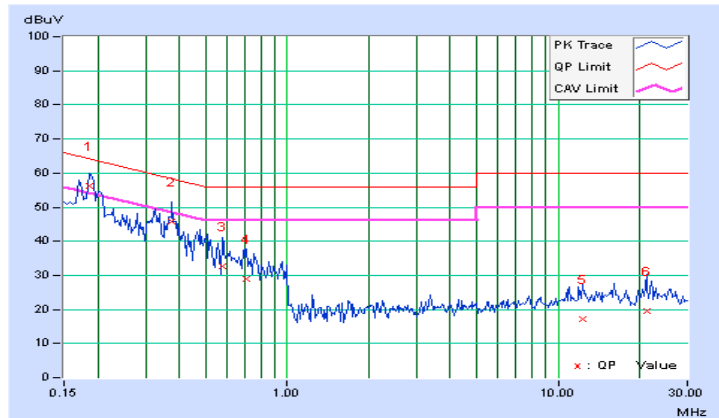

Phase	Neutral (N)	Detector Function	Quasi-Peak (QP) / Average (AV)
Channel	TX Channel 159	Test Mode	B

No	Freq. [MHz]	Corr. Factor (dB)	Reading Value [dB (uV)]		Emission Level [dB (uV)]		Limit [dB (uV)]		Margin (dB)	
			Q.P.	AV.	Q.P.	AV.	Q.P.	AV.	Q.P.	AV.
			1	<b>0.18906</b>	<b>9.92</b>	<b>46.74</b>	<b>25.14</b>	<b>56.66</b>	<b>35.06</b>	<b>64.08</b>
2	0.37266	9.95	34.61	13.97	44.56	23.92	58.44	48.44	-13.88	-24.52
3	0.56406	9.97	27.06	7.50	37.03	17.47	56.00	46.00	-18.97	-28.53
4	0.81797	9.99	16.80	6.17	26.79	16.16	56.00	46.00	-29.21	-29.84
5	14.94922	10.61	7.37	1.27	17.98	11.88	60.00	50.00	-42.02	-38.12
6	22.33594	10.72	7.15	-0.54	17.87	10.18	60.00	50.00	-42.13	-39.82

**Remark:**

1. Q.P. and AV. are abbreviations of quasi-peak and average individually.
2. The emission levels of other frequencies were very low against the limit.
3. Margin value = Emission level - Limit value
4. Correction factor = Insertion loss + Cable loss
5. Emission Level = Correction Factor + Reading Value.

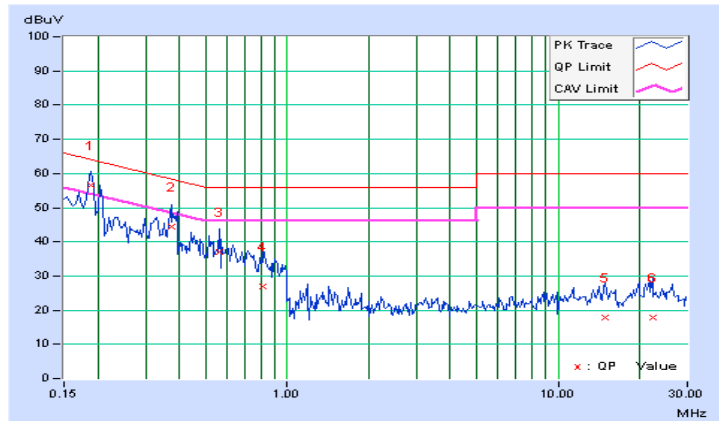

### 4.3 Transmit Power Measurement

#### 4.3.1 Limits of Transmit Power Measurement

Operation Band	EUT Category	LIMIT
U-NII-1	Outdoor Access Point	1 Watt (30 dBm) (Max. e.i.r.p)

\*B is the 26 dB emission bandwidth in megahertz

Per KDB 662911 Method of conducted output power measurement on IEEE 802.11 devices,

Array Gain = 0 dB (i.e., no array gain) for  $N_{ANT} \leq 4$ ;

Array Gain = 0 dB (i.e., no array gain) for channel widths  $\geq 40$  MHz for any  $N_{ANT}$ ;

Array Gain =  $5 \log(N_{ANT}/N_{SS})$  dB or 3 dB, whichever is less for 20-MHz channel widths with  $N_{ANT} \geq 5$ .

For power measurements on all other devices: Array Gain =  $10 \log(N_{ANT}/N_{SS})$  dB.

#### 4.3.2 Test Setup

##### FOR POWER OUTPUT MEASUREMENT

##### FOR OCCUPIED BANDWIDTH

#### 4.3.3 Test Instruments

Refer to section 4.1.2 to get information of above instrument.

#### 4.3.4 Test Procedure

##### FOR AVERAGE POWER MEASUREMENT

Method PM is used to perform output power measurement, trigger and gating function of wide band power meter is enabled to measure max output power of TX on burst and set the detector to average. Duty factor is not added to measured value.

##### FOR OCCUPIED BANDWIDTH

The transmitter output was connected to the spectrum analyzer through an attenuator. The bandwidth of the fundamental frequency was measured by spectrum analyzer with resolution bandwidth in the range of 1% to 5% of the anticipated emission bandwidth, and a video bandwidth at least 3x the resolution bandwidth and set the detector to SAMPLE. The width of a frequency band such that, below the lower and above the upper frequency limits, the mean powers emitted are each equal to a specified percentage 0.5 %of the total mean power of a given emission.

#### 4.3.5 Deviation fromTest Standard

No deviation.

#### 4.3.6 EUT Operating Conditions

The software provided by client to enable the EUT under transmission condition continuously at lowest, middle and highest channel frequencies individually.

### 4.3.7 Test Result

#### POWER OUTPUT:

Chan.	Freq. (MHz)	Maximum Conducted Power (dBm)				Total Power (mW)	Total Power (dBm)	Power Limit (dBm)	Pass / Fail
		Chain 0	Chain 1	Chain 2	Chain 3				
38	5190	13.03	13.29	12.45	13.06	<b>79.230</b>	18.99	24	Pass
46	5230	12.85	13.03	12.26	12.53	74.099	18.70	24	Pass
54	5270	12.65	13.23	12.37	12.55	74.693	18.73	24	Pass
62	5310	13.26	12.44	12.56	12.91	<b>76.296</b>	18.83	24	Pass
102	5510	13.26	12.51	12.68	12.10	73.761	18.68	24	Pass
110	5550	12.42	12.24	12.41	12.97	71.440	18.54	24	Pass
134	5670	13.26	12.68	12.53	12.53	<b>75.531</b>	18.78	24	Pass
151	5755	13.33	12.95	13.02	13.21	82.238	19.15	30	Pass
159	5795	13.67	13.13	12.89	13.13	<b>83.853</b>	19.24	30	Pass

Note:

For U-NII-2A, U-NII-2C Band:

Chain 0

$$1. 11\text{dBm} + 10\log ( 41.19 ) = 27.15$$



26dB Bandwidth:

Chan.	Freq. (MHz)	26dBc Bandwidth (MHz)				Pass / Fail
		Chain 0	Chain 1	Chain 2	Chain 3	
38	5190	41.30	41.37	41.13	40.97	Pass
46	5230	41.18	40.93	41.17	41.01	Pass
54	5270	41.19	41.14	41.25	41.19	Pass
62	5310	41.29	41.01	41.32	41.17	Pass
102	5510	41.34	41.07	40.98	41.01	Pass
110	5550	41.15	41.18	41.10	41.22	Pass
134	5670	41.41	40.95	41.14	41.21	Pass

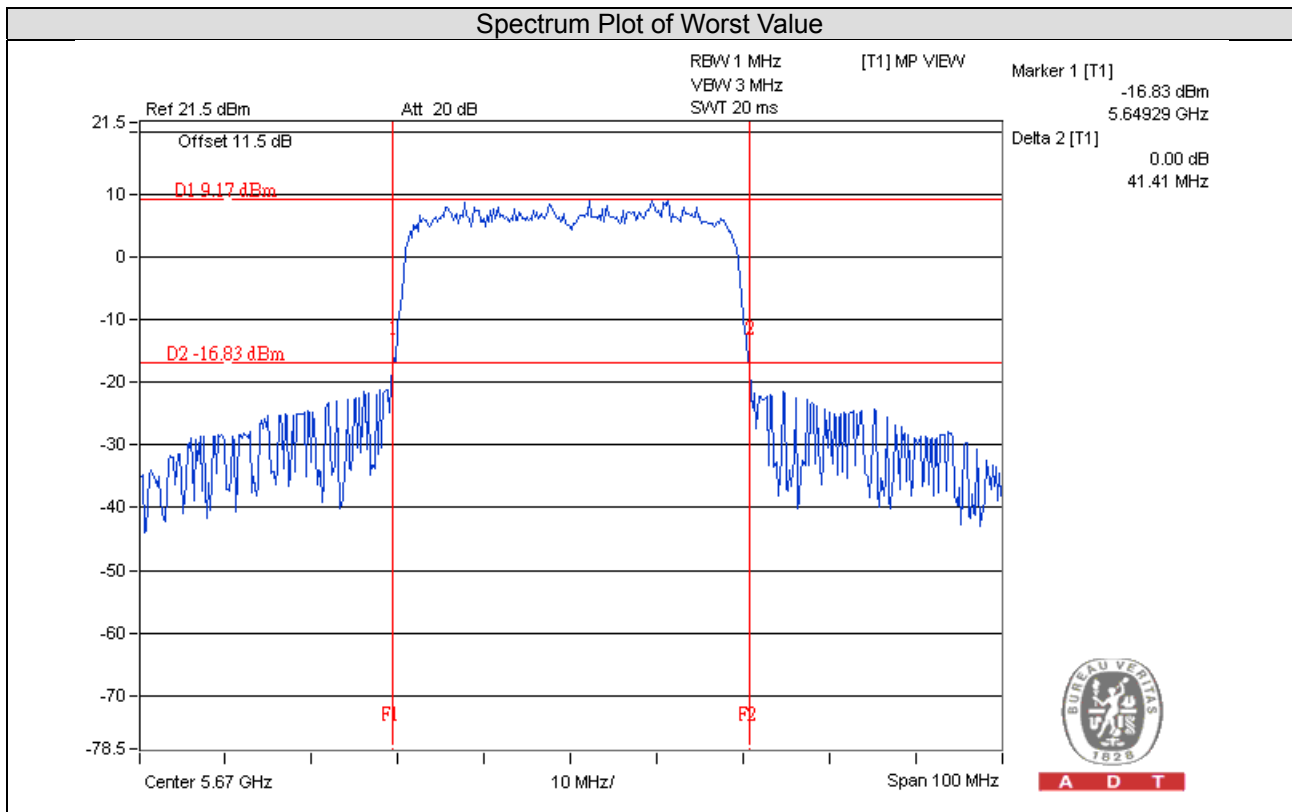

**OCCUPIED BANDWIDTH:**

Channel	Frequency (MHz)	Occupied Bandwidth (MHz)				Pass / Fail
		Chain 0	Chain 1	Chain 2	Chain 3	
38	5190	37.80	37.68	37.80	37.92	Pass
46	5230	37.68	37.68	37.68	37.68	Pass
54	5270	37.80	37.68	37.68	37.80	Pass
62	5310	37.68	37.80	37.80	37.80	Pass
102	5510	37.80	37.80	37.68	37.68	Pass
110	5550	37.80	37.80	37.68	37.92	Pass
134	5670	37.80	37.68	37.68	37.92	Pass
151	5755	37.80	37.56	37.68	37.80	Pass
159	5795	37.68	37.68	37.80	37.80	Pass

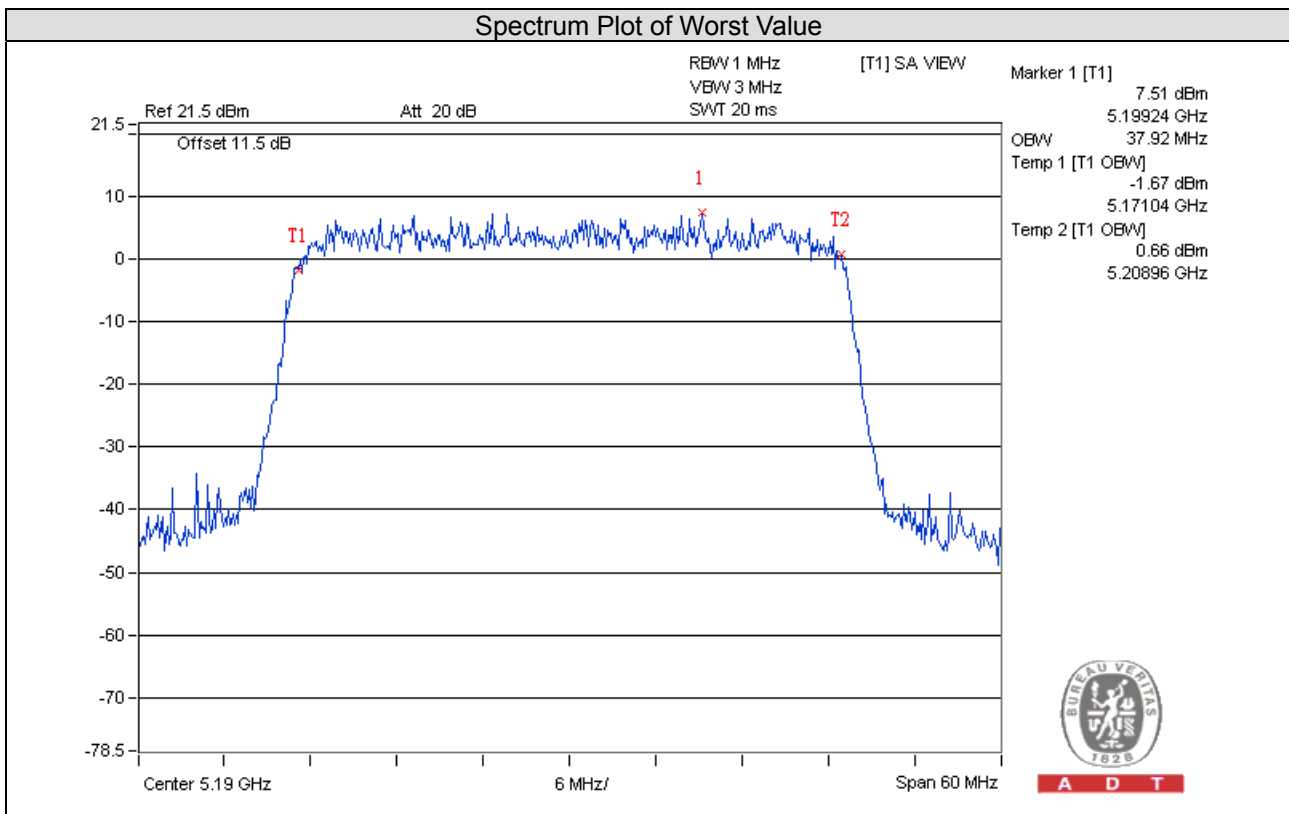

**EUT MAXIMUM CONDUCTED POWER**

Frequency Band (MHz)	Max. Power	
	Output Power (mW)	Output Power (dBm)
5250~5350	76.296	18.83
5470~5725	75.531	18.78

Note: Manufacturer provides Transmit Power Control description to meet this requirement.

#### 4.4 Peak Power Spectral Density Measurement

##### 4.4.1 Limits of Peak Power Spectral Density Measurement

Operation Band	EUT Category		LIMIT
U-NII-1		Outdoor Access Point	17dBm/ MHz
		Fixed point-to-point Access Point	
		Indoor Access Point	
	√	Mobile and Portable client device	11dBm/ MHz
U-NII-2A		√	11dBm/ MHz
U-NII-2C		√	11dBm/ MHz
U-NII-3		√	30dBm/ 500kHz

##### 4.4.2 Test Setup

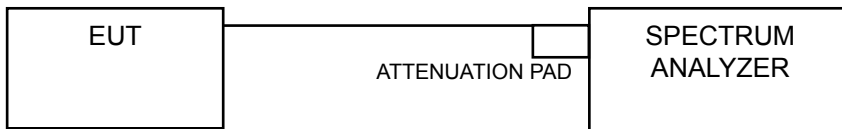

##### 4.4.3 Test Instruments

Refer to section 4.1.2 to get information of above instrument.

##### 4.4.4 Test Procedures

For U-NII-1, U-NII-2A, U-NII-2C band:

- Set span to encompass the entire emission bandwidth (EBW) of the signal.
- Set RBW = 1MHz, Set VBW ≥ 1 MHz, Detector = RMS
- Set Channel power measure = 1MHz
- Sweep time = auto, trigger set to “free run”.
- Trace average at least 100 traces in power averaging mode.
- Record the max value and add 10 log (1/duty cycle)

For U-NII-3 band:

- Set span to encompass the entire emission bandwidth (EBW) of the signal.
- Set RBW = 300 kHz, Set VBW ≥ 3 RBW, Detector = RMS
- Sweep time = auto, trigger set to “free run”.
- Trace average at least 100 traces in power averaging mode.
- Record the max value and add 10 log (1/duty cycle)
- Scale the observed power level to an equivalent value in 500 kHz by adjusting (reducing) the measured power by a bandwidth correction factor (BWCF) where  $BWCF = 10\log(500\text{ kHz}/300\text{kHz})$

##### 4.4.5 Deviation from Test Standard

No deviation.

##### 4.4.6 EUT Operating Conditions

Same as Item 4.3.6.

#### 4.4.7 Test Results

Chan.	Freq. (MHz)	PSD (dBm)				Total PSD w/o duty factor (dBm)	Duty factor	Total PSD with duty factor (dBm)	Max. Limit (dBm)	Pass / Fail
		Chain 0	Chain 1	Chain 2	Chain 3					
38	5190	-4.14	-3.64	-4.88	-4.41	1.77	0.24	2.01	11	Pass
46	5230	-4.31	-3.76	-4.65	-4.68	1.68	0.24	1.92	11	Pass
54	5270	-4.22	-3.71	-4.32	-4.62	1.81	0.24	2.05	11	Pass
62	5310	-4.57	-4.18	-4.89	-4.47	1.50	0.24	1.74	11	Pass
102	5510	-5.00	-4.55	-5.27	-4.63	1.16	0.24	1.40	11	Pass
110	5550	-4.89	-4.46	-5.49	-4.61	1.17	0.24	1.41	11	Pass
134	5670	-4.48	-4.62	-5.84	-4.84	1.10	0.24	1.34	11	Pass

Note:

1. Method 1 of power density measurement of KDB 662911 is using for calculating total power density. Total power density is summing entire spectra across corresponding frequency bins on the various outputs by computer.
2. Refer to section 3.3 for duty cycle spectrum plot.
3. The transmit signals are completely uncorrelated, Directional gain= 4dBi < 6dBi, so the power density limit no need to reduced

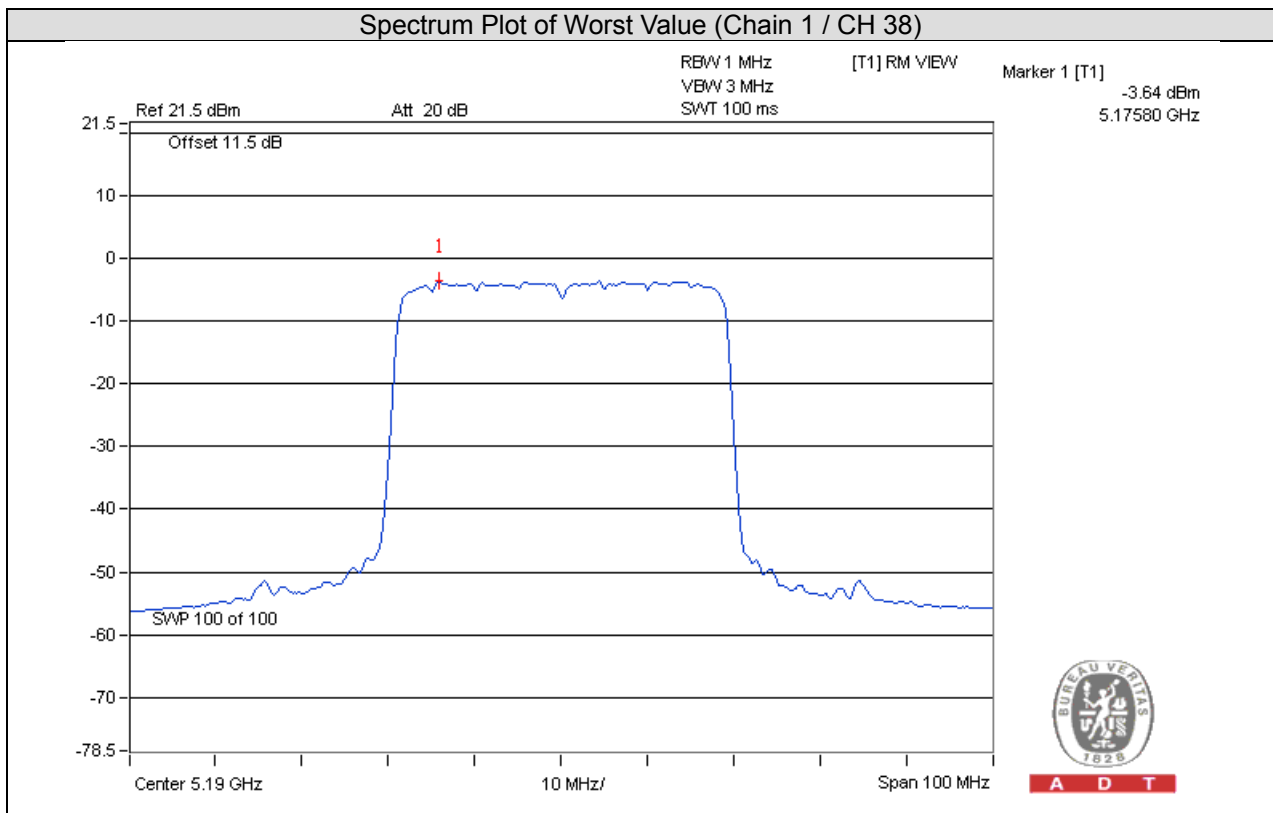

For U-NII-3 Band

TX chain	Chan.	Freq. (MHz)	PSD (dBm /300kHz)	PSD (dBm /500kHz)	10 log (N=4) dB	Total PSD without Duty Factor (dBm/500kHz)	Duty Factor	Total PSD with Duty Factor (dBm/500kHz)	Limit (dBm /500kHz)	Pass /Fail
0	151	5755	-13.15	-10.93	6.02	-4.91	0.24	-4.67	30	Pass
	159	5795	-13.10	-10.88	6.02	-4.86	0.24	-4.62	30	Pass
1	151	5755	-13.04	-10.82	6.02	-4.80	0.24	-4.56	30	Pass
	159	5795	-12.96	-10.74	6.02	-4.72	0.24	-4.48	30	Pass
2	151	5755	-13.45	-11.23	6.02	-5.21	0.24	-4.97	30	Pass
	159	5795	-12.66	-10.44	6.02	-4.42	0.24	-4.18	30	Pass
3	151	5755	-11.39	-9.17	6.02	-3.15	0.24	-2.91	30	Pass
	159	5795	-11.87	-9.65	6.02	-3.63	0.24	-3.39	30	Pass

Note:

1. Method 1 of power density measurement of KDB 662911 is using for calculating total power density. Total power density is summing entire spectra across corresponding frequency bins on the various outputs by computer.
2. Refer to section 3.3 for duty cycle spectrum plot.
3. The transmit signals are completely uncorrelated, Directional gain= 4dBi < 6dBi, so the power density limit no need to reduced

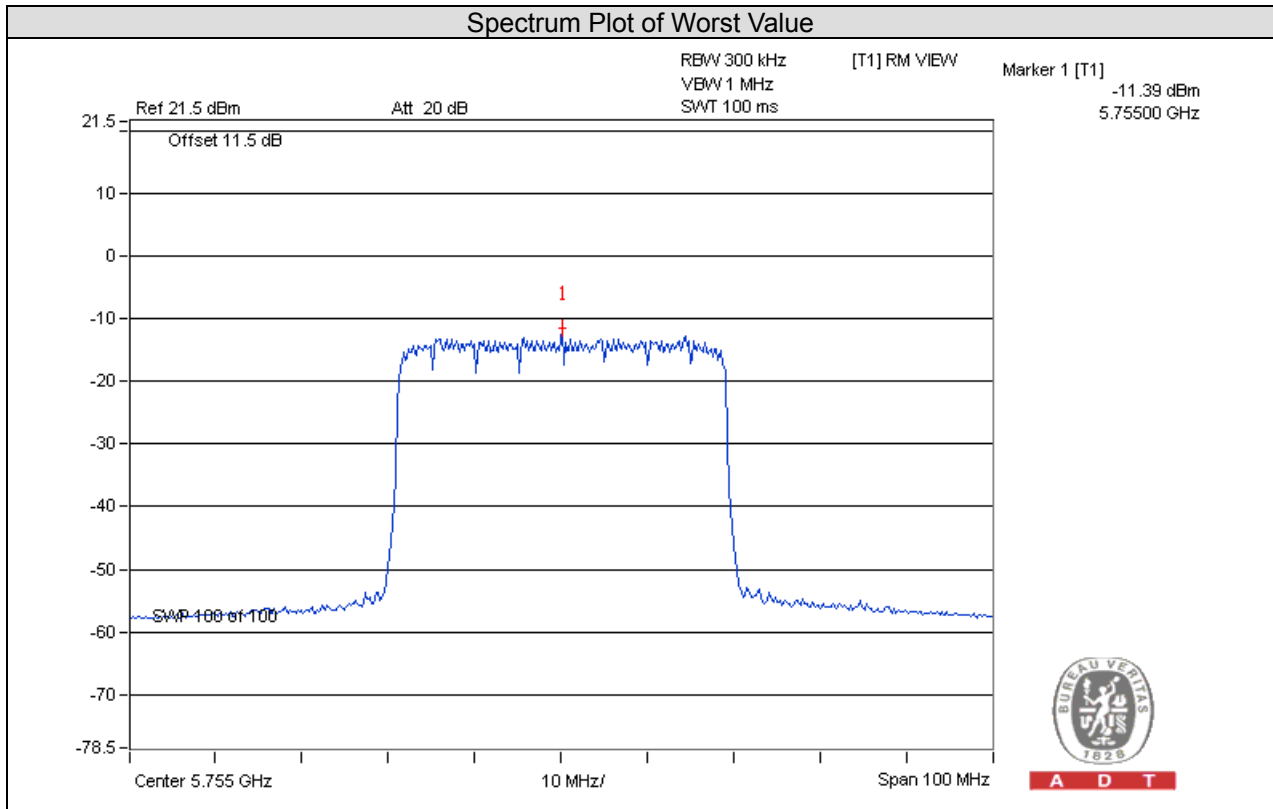

## 4.5 Frequency Stability

### 4.5.1 Limits of Frequency Stability Measurement

The frequency of the carrier signal shall be maintained within band of operation

### 4.5.2 Test Setup

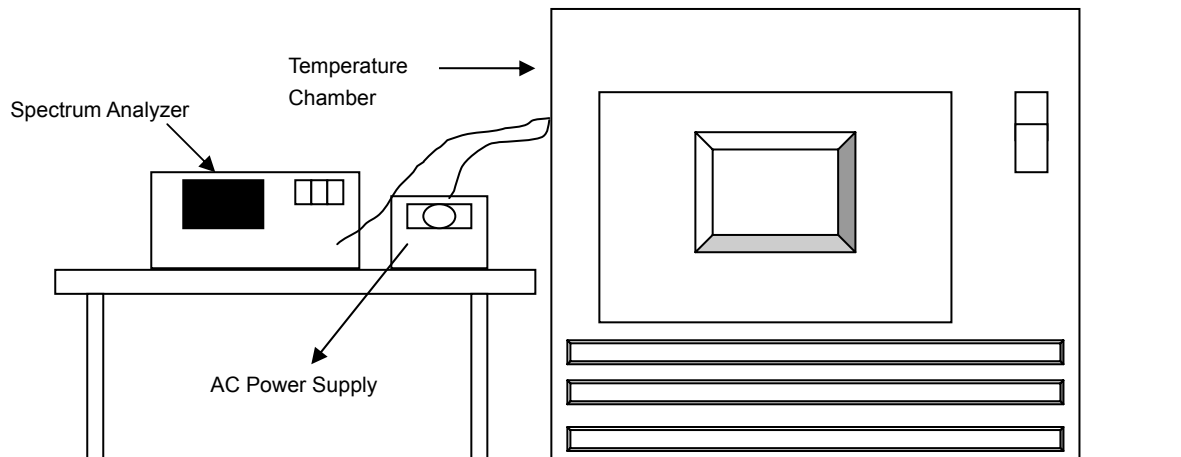

### 4.5.3 Test Instruments

Refer to section 4.1.2 to get information of above instrument.

### 4.5.4 Test Procedure

- a. The EUT was placed inside the environmental test chamber and powered by nominal AC voltage.
- b. Turn the EUT on and couple its output to a spectrum analyzer.
- c. Turn the EUT off and set the chamber to the highest temperature specified.
- d. Allow sufficient time (approximately 30 min) for the temperature of the chamber to stabilize, turn the EUT on and measure the operating frequency after 2, 5, and 10 minutes.
- e. Repeat step 2 and 3 with the temperature chamber set to the lowest temperature.
- f. The test chamber was allowed to stabilize at +20 degree C for a minimum of 30 minutes. The supply voltage was then adjusted on the EUT from 85% to 115% and the frequency record.

### 4.5.5 Deviation from Test Standard

No deviation.

### 4.5.6 EUT Operating Condition

Set the EUT transmit at un-modulation mode to test frequency stability.



#### 4.5.7 Test Results

Frequency Stability Versus Temp.

Operating Frequency: 5190MHz

Temp.  
(



## 4.6 6dB Bandwidth Measurement

### 4.6.1 Limits of 6dB Bandwidth Measurement

The minimum of 6dB Bandwidth Measurement is 0.5MHz.

### 4.6.2 Test Setup

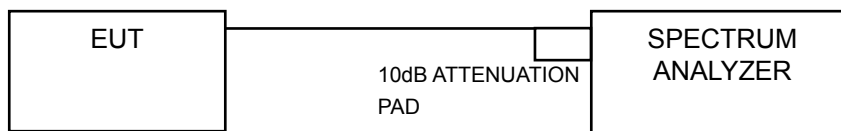

### 4.6.3 Test Instruments

Refer to section 4.1.2 to get information of above instrument.

### 4.6.4 Test Procedure

#### MEASUREMENT PROCEDURE REF

- Set resolution bandwidth (RBW) = 100kHz
- Set the video bandwidth (VBW)  $\geq 3 \times$  RBW, Detector = Peak.
- Trace mode = max hold.
- Sweep = auto couple.
- Measure the maximum width of the emission that is constrained by the frequencies associated with the two amplitude points (upper and lower) that are attenuated by 6 dB relative to the maximum level measured in the fundamental emission

### 4.6.5 Deviation from Test Standard

No deviation.

### 4.6.6 EUT Operating Condition

The software provided by client to enable the EUT under transmission condition continuously at lowest, middle and highest channel frequencies individually.



## 5 Pictures of Test Arrangements

Please refer to the attached file (Test Setup Photo).

## Appendix – Information on the Testing Laboratories

We, Bureau Veritas Consumer Products Services (H.K.) Ltd., Taoyuan Branch, were founded in 1988 to provide our best service in EMC, Radio, Telecom and Safety consultation. Our laboratories are accredited and approved according to ISO/IEC 17025.

If you have any comments, please feel free to contact us at the following:

**Linko EMC/RF Lab**

Tel: 886-2-26052180

Fax: 886-2-26051924

**Hsin Chu EMC/RF/Telecom Lab**

Tel: 886-3-6668565

Fax: 886-3-6668323

**Hwa Ya EMC/RF/Safety**

Tel: 886-3-3183232

Fax: 886-3-3270892

**Email:** [service.adt@tw.bureauveritas.com](mailto:service.adt@tw.bureauveritas.com)

**Web Site:** [www.bureauveritas-adt.com](http://www.bureauveritas-adt.com)

The address and road map of all our labs can be found in our web site also.

--- END ---