

# Report On

## Application for Grant of Equipment Authorization of the Nextivity Inc. Cel-Fi Q4K-CBRS Cellphone Signal Booster

In accordance with:  
FCC CFR 47 Part 20  
RSS-131

Prepared for:  
Nextivity Inc.  
16550 West Bernardo Drive, Bldg 5, Suite 550,  
San Diego, CA 92127, USA

Issue Date: February 2023  
Document Number: 72176539C1 | Issue: 01

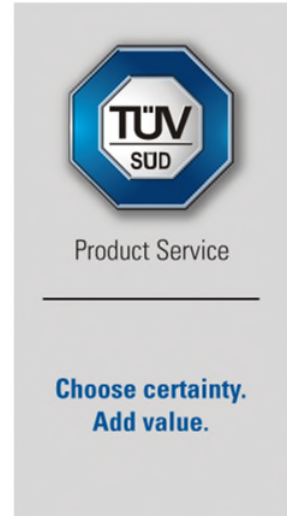

RESPONSIBLE FOR	NAME	TITLE	DATE	SIGNATURE
Prepared By	Ferdinand S. Custodio	Senior RADIO Test Engineer / Wireless Team Lead	02/03/2023	
Authorized Signatory	Omar Castillo	Senior EMC/Wireless Test Engineer	02/03/2023	

Signatures in this approval box have checked this document in line with the requirements of TÜV SÜD Product Service document control rules.

### EXECUTIVE SUMMARY

Report and test data representing the EUT are verified and the EUT itself found to be in compliance with FCC CFR 47 Part 20 and RSS-131 for ISED

 A2LA Cert. No. 2955.13	<b>DISCLAIMER AND COPYRIGHT</b> This report has been prepared by TÜV SÜD America with all reasonable skill and care. The document is confidential to the potential Client and TÜV SÜD America. No part of this document may be reproduced without the prior written approval of TÜV SÜD America. © 2019 TÜV SÜD America. <b>ACCREDITATION</b> Our A2LA Accreditation does not cover opinions and interpretations and any expressed are outside the scope of our A2LA Accreditation.
---	--

TÜV SÜD America, Inc.  
10040 Mesa Rim Road  
San Diego, CA 92121-2912

TÜV SÜD America, Inc.  
Rancho Bernardo Facility  
16936 Via Del Campo  
San Diego, CA 92127

Phone: 858 678 1400  
www.tuv-sud-america.com



FCC ID: NU: YETQ44-1M34CNU and CU: YETQ41-RECU  
IC: NU: 9892A-Q441M34CNU and CU: 9892A-Q41RECU

## Contents

<b>1</b>	<b>Report Summary .....</b>	<b>2</b>
1.1	Report Modification Record.....	2
1.2	Introduction.....	2
1.3	Brief Summary of Results .....	4
1.4	Product Information .....	6
1.5	Deviations from the Standard.....	14
1.6	EUT Modification Record .....	14
1.7	Test Methods.....	14
1.8	Test Location.....	15
1.9	Test Facility Registration .....	15
<b>2</b>	<b>Test Details .....</b>	<b>17</b>
2.1	Authorized Frequency Band Verification.....	17
2.2	Authorized CMRS Provider .....	30
2.3	Maximum Power Measurement and Booster Gain Computation.....	68
2.4	Intermodulation Product .....	88
2.5	Out Of Band Emissions .....	99
2.6	Conducted Spurious Emissions .....	120
2.7	Noise Limit.....	165
2.8	Uplink Inactivity .....	170
2.9	Variable Booster Gain .....	175
2.10	Occupied Bandwidth .....	184
2.11	Oscillation Detection.....	217
2.12	Field Strength of Spurious Radiation .....	243
2.13	Out of Band Gain Limit.....	271
2.14	Frequency Stability.....	278
<b>3</b>	<b>Test Equipment Used.....</b>	<b>294</b>
3.1	List of absolute measuring and other principal items of test equipment.....	294
<b>4</b>	<b>Measurement Uncertainty .....</b>	<b>296</b>
4.1	Conducted Antenna Port Measurement.....	296
<b>5</b>	<b>Accreditation, Disclaimers and Copyright.....</b>	<b>297</b>



FCC ID: NU: YETQ44-1M34CNU and CU: YETQ41-RECU  
 IC: NU: 9892A-Q441M34CNU and CU: 9892A-Q41RECU

# 1 Report Summary

## 1.1 Report Modification Record

Alterations and additions to this report will be issued to the holders of each copy in the form of a complete document.

Issue	Description of Change	Date of Issue
1	Initial Release	02/03/2023

## 1.2 Introduction

Objective	The EUT is a family model of Quatra 4000 series signal boosters. Protocol tests were leverage from Quatra 4000 Model Q44-1234CNU and Q41-5ECU with FCC ID YETQ44-1234CNU/YETQ41-5ECU and IC Number 9298A-Q441234CNU/9298A-Q415ECU (see table 1.3 for details). The two model variants are identical for all the bands presented in this test report. The difference between the two models is the EUT support of LTE B48 which is covered under a separate KDB935210 D05 test report.
Manufacturer	Nextivity Inc. 16550 West Bernardo Drive, Bldg 5, Suite 550, San Diego, CA 92127, USA
Applicant Contact Information	CK Li Sr. Principal Engineer, Regulatory CLi@NextivityInc.com (858) 485-9442
FCC ID	NU: YETQ44-1M34CNU and CU: YETQ41-RECU
ISED Certification Number:	NU: 9892A-Q441M34CNU and CU: 9892A-Q41RECU
Model Number(s)	NU: Q44-1M34CNU; CU: I44-1M34CNU
Test Specification/Issue/Date	<ul style="list-style-type: none"> <li>FCC CFR 47 Part 20 (October 1, 2022).</li> <li>RSS-131 – Zone Enhancers (Issue 4, December 2022).</li> </ul>
Start of Test	November 06, 2022
Finish of Test	February 02, 2023
Name of Engineer(s)	Ferdinand S. Custodio Miguel Angel Rabago Garcia



FCC ID: NU: YETQ44-1M34CNU and CU: YETQ41-RECU  
IC: NU: 9892A-Q441M34CNU and CU: 9892A-Q41RECU

Related Document(s)

- Product Spec for RFQ\_Q4000 Phantom Bride\_CBRS\_v2.0.pdf
- 72146075C Nextivity FCC Part 20 W B5 L B4 B12 B13 25 30 71 Test Report.pdf (Part1 to Part 4) Issued by TÜV SÜD America Inc, 10040 Mesa Rim Road, San Diego, CA 92121-2912 December 2019
- KDB935210 (D04 Provider Specific Booster Measurements v02r03) Provider-Specific Consumer Signal Booster Compliance Measurements Guidance.
- Supporting documents for EUT certification are separate exhibits.



FCC ID: NU: YETQ44-1M34CNU and CU: YETQ41-RECU  
 IC: NU: 9892A-Q441M34CNU and CU: 9892A-Q41RECU

### 1.3 Brief Summary of Results

A brief summary of the tests carried out in accordance with FCC CFR 47 Part 20 with cross-reference to the corresponding requirements of KDB935210 D04 and ISED RSS-131 is shown below.

Section	Spec Clause			Test Description	Results
	FCC Part	KDB935210 D04	RSS		
2.1	20.21 (e)(3) Frequency Bands	7.1.1	-	Authorized Frequency Band Verification	Compliant*
2.2	20.21 (e)(3) Frequency Bands 20.21 (e)(4) Self-Monitoring	7.1.2	-	Test Authorized CMRS provider test	Compliant*
2.3	20.21(e)(9)(i)(D) Power Limits 20.21(e)(9)(i)(B) Bidirectional Capability 20.21(e)(9)(i)(C)(2) Booster Gain Limits	7.2 7.3	RSS-131 Clause 6.1.2 RSS-131 Clause 8.3	Maximum Power measurement procedure Maximum Booster Gain Computer	Compliant**
2.4	20.21(e)(9)(i)(G) Intermodulation Limit	7.4	RSS-131 Clause 8.6	Intermodulation Product	Compliant*
2.5	20.21(e)(9)(i)(F) Out of Band Emission Limit	7.5	RSS-131 Clause 8.5	Out-of-Band Emissions	Compliant*
2.6	20.21(e)(9)(i)(F) Out of Band Emission Limit 2.1051 Measurements required: Spurious emissions at antenna terminals. 22.917 (a) Emission limitations for cellular equipment. 24.238 (a) Emission limitations for Broadband PCS equipment.	7.6	RSS-13 8.5	Conducted Spurious Emissions	Compliant
2.7	20.21(e)(9)(i)(A) Noise Limits 20.21(e)(9)(i)(I) Transmit Power Off Mode	7.7	RSS-131 Clause 8.1 RSS-131 Clause 8.7	Noise Limits	Compliant*
2.8	20.21(e)(9)(i)(J) Uplink Inactivity	7.8	RSS-131 Clause 8.8	Uplink inactivity	Compliant*
2.9	20.21(e)(9)(i)(C)(1) Booster Gain Limits 20.21(e)(9)(i)(I) Transmit Power Off Mode	7.9	RSS-131 Clause 8.2 RSS-131 Clause 8.7	Variable Booster Gain	Compliant*
2.10	2.1049 Measurements required: Occupied bandwidth. 22.917 (b) Emission limitations for cellular equipment. 24.238 (b) Emission limitations for Broadband PCS equipment.	7.10	RSS-Gen 6.7	Occupied Bandwidth	Compliant
2.11	20.21(e)(9)(ii)(A) Anti-Oscillation	7.11	RSS-131 Clause 6.1.1	Oscillation Detection	Compliant*
-	20.21(e)(9)(i)(C)(2)(iii) Automatic Feedback Cancellation	7.12	-	Mobile Booster Automatic Feedback Cancellation	N/A; Applicable to Mobile Booster



FCC ID: NU: YETQ44-1M34CNU and CU: YETQ41-RECU  
 IC: NU: 9892A-Q441M34CNU and CU: 9892A-Q41RECU

2.12	2.1053 Measurements required: Field strength of spurious radiation. 22.917 (a) Emission limitations for cellular equipment. 24.238 (a) Emission limitations for Broadband PCS equipment. 27.53 (h)(1) / 27.53 (g) / 27.53 (c)(1), (2), (5) Emission limits.	7.13	RSS 132 Clause 5.5 RSS 133 Clause 6.5 RSS 139 Clause 6.6 RSS 130 Clause 4.7 RSS 195 Clause 5.6.1	Radiated Spurious Emissions	Compliant
-	20.21(e)(9)(i)(B) Bidirectional Capability 20.21(e)(3) Frequency Band	7.14	-	Spectrum Block Filtering	N/A***
2.13	20.21(e)(9)(i)(E) Out of Band Gain Limit	7.15	RSS-131 Clause 8.4	Out of Band Gain	Compliant*
2.14	2.1055 Measurements required: Frequency stability. 22.355 Frequency tolerance 24.235 Frequency stability. 27.54 Frequency stability.	7.16	RSS 132 Clause 5.3 RSS 133 Clause 6.3 RSS 139 Clause 6.4 RSS 130 Clause 4.5 RSS 195 Clause 5.4	Frequency Stability	Compliant

*Compliant\** Test results leveraged from 72146075C Nextivity FCC Part 20 W B5 L B4 B12 B13 25 30 71 Test Report.pdf

*Compliant\*\** Limited test results leveraged from 72146075C Nextivity FCC Part 20 W B5 L B4 B12 B13 25 30 71 Test Report.pdf

*N/A\*\*\** Not Applicable. The EUT does not utilize spectrum block filtering.



FCC ID: NU: YETQ44-1M34CNU and CU: YETQ41-RECU  
 IC: NU: 9892A-Q441M34CNU and CU: 9892A-Q41RECU

**1.4 Product Information**

**1.4.1 Technical Description**

The Equipment Under Test (EUT) was a Nextivity Inc., Cel-Fi Q4K-CBRS Cellphone Signal Booster. The EUT is a WCDMA/LTE “Provider-Specific” Signal Booster to improve voice and data cellular performance in large enterprise environments. The EUT is capable to support up to Four (4) carriers (via separated donor antenna ports).

The EUT consists of two separate units: the Network Unit (NU), and the Coverage Unit (CU). The NU comprises a transmitter and receiver which communicate with the cell tower and the CU. CU comprises a transmitter and receiver which communicate with the User Equipment (e.g., Cell phone) and the NU. Figure below illustrates the typical application. The system operates with the need to install external antennas.

Users place the NU in an area with the strongest signal from the carrier networks. The CUs are then either placed in the center of the home or office, or in the area where the best signal quality is most needed. The NU and CU are placed at varying distances apart and are communicated via Ethernet cables.

One NU can connect up to Six (6) CUs via Ethernet Cat 5 cables. The NU transmits and receives Cellular signals from the base station and operates similar to a cellular handset. The CU transmits and receives signals with the cellular handset and operates on frequencies similar to the cellular base station. CU coverage area >10m

NU includes an FCC certified Cellular modem. With the use of the modem, it allows the system to access internet and for product registration, software updates, capturing and displaying details metrics of the system.

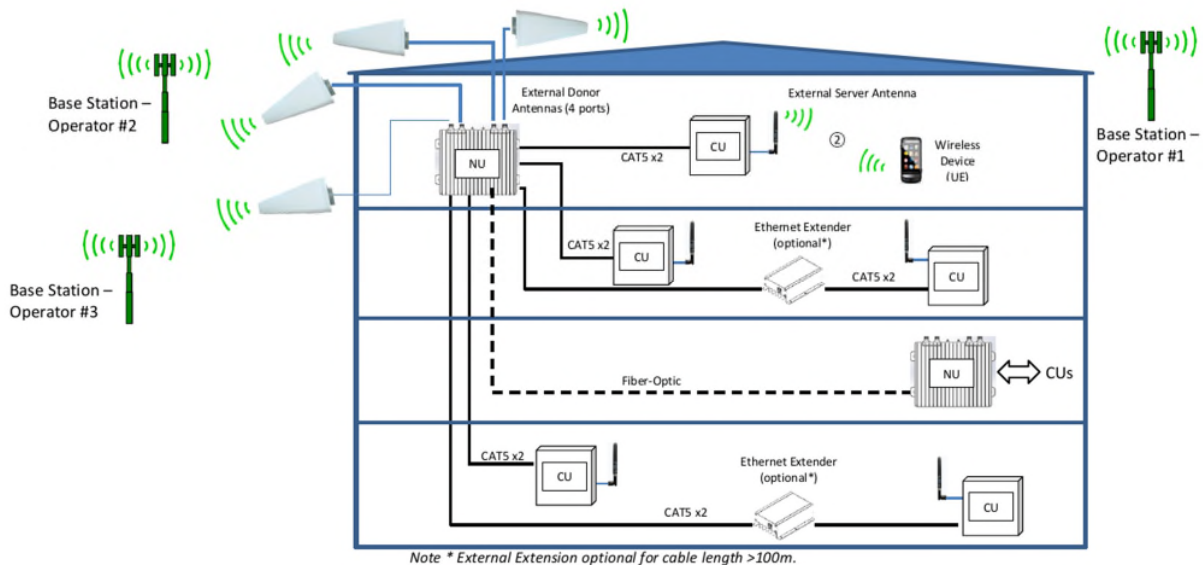



FCC ID: NU: YETQ44-1M34CNU and CU: YETQ41-RECU  
 IC: NU: 9892A-Q441M34CNU and CU: 9892A-Q41RECU

Up to 2 bands on each port																				
Ant Port	1					2					3					4				
Operator #	A - A					B - T					C - V					D - P				
Max support BW	30 MHz					40 MHz					30 MHz					20 MHz				
Band	4	5	12	25	30	4	12	25	71	4	13	25	48							
Band Combination	✓		✓			✓				✓	✓		✓							
	✓		✓		✓	✓	✓			✓	✓	✓								
	✓		✓		✓	✓	✓													
		✓	✓		✓	✓		✓												
			✓	✓	✓	✓	✓	✓	✓											
				✓	✓	✓	✓	✓	✓											

**1.4.2 EUT Specification**

EUT Description	Cellphone Signal Booster
Trade Name	Cel-Fi™
Model Name	Cel-Fi Q4K-CBRS
Model Number(s)	NU: Q44-1M34CNU; CU: I44-1M34CNU
Rated Voltage	NU: 120 VAC 60Hz CU: 54V DC (powered from NU via 2 Ethernet cables)
Mode Verified	WCDMA Band 5 and LTE Band 4, 12, 13 and 25
Frequency Bands	WCDMA Band 5:                   UL: 824 - 849MHz DL: 869 - 894MHz LTE Band 4:                        UL: 1710 - 1755MHz DL: 2110 - 2155MHz LTE Band 12:                       UL: 699 - 716MHz DL: 729 - 746MHz LTE Band 13:                       UL: 777 - 787MHz DL: 746 - 756MHz LTE Band 25:                       UL: 1850 - 1915MHz DL: 1930 - 1995MHz





FCC ID: NU: YETQ44-1M34CNU and CU: YETQ41-RECU  
 IC: NU: 9892A-Q441M34CNU and CU: 9892A-Q41RECU

Rated Power

Signal Bandwidth (MHz)	WCDMA Band 5		LTE Band 4, 25		LTE Band 12, 13	
	DL (dBm)	UL (dBm)	DL (dBm)	UL (dBm)	DL (dBm)	UL (dBm)
5	(WCDMA) 13 (LTE) 16	(WCDMA) 22 (LTE) 20	Max. 16	22	Max. 16	22 (B12, 13) 19 (B30)
10						
15					N/A	
20	N/A		N/A		N/A	

Capability

WCDMA (Band 5), LTE (Band 4, 12, 13 and 25)

Channel Bandwidth

WCDMA Band 5: 5MHz  
 LTE Band 4, 25: 5MHz, 10MHz, 15MHz and 20MHz  
 LTE Band 12, 13: 5MHz and 10MHz

Primary Unit (EUT)

- Production
- Pre-Production
- Engineering

Manufacturer Declared Temperature Range

0°C to 40°C

Antenna Type

External Antenna

Manufacturer

Refer to the Antenna information supplied by the manufacture

Antenna Model

Refer to the Antenna information supplied by the manufacture



FCC ID: NU: YETQ44-1M34CNU and CU: YETQ41-RECU  
 IC: NU: 9892A-Q441M34CNU and CU: 9892A-Q41RECU

Maximum Antenna System  
 (Antenna + Cable) Gain

Port	Max System (Antenna & Cable) Gain
CU	0.01 dBi for WCDMA Band 5 1.16 dBi for LTE Band 4 1.44 dBi for LTE Band 12 1.16 dBi for LTE Band 13 0.14 dBi for LTE Band 25
NU Port 1	8.32 dBi for WCDMA Band 5 6.63 dBi for LTE Band 4 8.08 dBi for LTE Band 12 6.52 dBi for LTE Band 25
NU Port 2	6.63 dBi for LTE Band 4 8.08 dBi for LTE Band 12 6.52 dBi for LTE Band 25
NU Port 3	6.63 dBi for LTE Band 4 7.99 dBi for LTE Band 13 6.52 dBi for LTE Band 25



FCC ID: NU: YETQ44-1M34CNU and CU: YETQ41-RECU  
 IC: NU: 9892A-Q441M34CNU and CU: 9892A-Q41RECU

**1.4.3 Transmit Frequency Table**

Mode	Signal Bandwidth (MHz)	Tx Frequency (MHz)	Emission Designator	EIRP	
				Max. Power Avg (dBm)	Max. Power Avg (W)
WCDMA Band 5 Downlink	5	871.4 – 891.6	3M88F9W	15.33	0.034119291
	5 (3 Carriers)	871.4 – 891.6		17	0.050118723
WCDMA Band 5 Uplink	5	826.4 – 846.6	4M05F9W	29.74	0.941889597
	5 (3 Carriers)	826.4 – 846.6		30	1
LTE Band 4 Downlink	5	2110 - 2155	4M72F9W	16.37	0.043351088
	10	2110 - 2155	9M31F9W	17	0.050118723
	15	2110 - 2155	13M6F9W	16.89	0.048865236
	20	2110 - 2155	18M4F9W	16.46	0.044258837
LTE Band 4 Uplink	5	1710 - 1755	4M64F9W	28.16	0.654636174
	10	1710 - 1755	9M26F9W	30	1
	15	1710 - 1755	13M6F9W	28.57	0.719448978
	20	1710 - 1755	18M4F9W	28.31	0.677641508
LTE Band 12 Downlink	5	729 - 746	4M73F9W	17	0.050118723
	10	729 - 746	9M24F9W	16.95	0.049545019
LTE Band 12 Uplink	5	699 - 716	4M64F9W	30	1
	10	699 - 716	9M25F9W	29.98	0.995405417
LTE Band 13 Downlink	5	746 - 756	4M62F9W	17	0.050118723
	10	746 - 756	9M20F9W	16.82	0.048083935
LTE Band 13 Uplink	5	777 - 787	4M72F9W	29.66	0.924698174
	10	777 - 787	9M17F9W	30	1
LTE Band 25 Downlink	5	1932.5 – 1992.5	4M63F9W	15.3	0.033884416
	10	1935 – 1990	8M96F9W	15.61	0.036391504
	15	1937.5 – 1987.5	13M4F9W	16.68	0.046558609
	20	1940 – 1985	17M9F9W	17	0.050118723
LTE Band 25 Uplink	5	1852.5 – 1912.5	4M47F9W	27.53	0.566239289
	10	1855 – 1910	8M98F9W	30	1
	15	1857.5 – 1907.5	13M4F9W	28.29	0.674528028
	20	1860 – 1905	17M9F9W	28.16	0.654636174

Note: EIRP was computed with power output results on section 2.3.9 and maximum system gain from table 1.4.2



FCC ID: NU: YETQ44-1M34CNU and CU: YETQ41-RECU  
 IC: NU: 9892A-Q441M34CNU and CU: 9892A-Q41RECU

#### 1.4.4 Test Configuration

Configuration Number	Description
A	Test Mode - Downlink (CU TX). Input signal is applied to antenna port of NU. Output is monitored from antenna port of CU. (refer to 1.4.4 Figure 3)
B	Test Mode - Uplink (NU TX). Input signal is applied to antenna port of CU. Output is monitored from antenna port of NU. (refer to 1.4.4 Figure 2)
C	Normal Mode - Downlink (CU TX). Base Station Simulator is employed to send a modulated signal to antenna port of NU. Antenna port of CU is terminated with a 50Ω load. (refer to 1.4.4 Figure 1)
D	Normal Mode - Uplink (NU TX). Base Station Simulator is employed to send a modulated signal to antenna port of NU. Input signal is applied to antenna port of CU. (refer to 1.4.4 Figure 1)
E	Inter-modulation. Test setup identical to Test Configuration A and B above with the addition of another signal applied to the input of the EUT. A coupler was used in the setup to ensure that the additional signal is directed to the EUT input port. (refer to 1.4.4 Figure 5)
F	Max Downlink noise limit testing - A 50 Ohm Termination is connected to the NU antenna port and Measure the Noise Limit at the CU antenna port. (refer to 1.4.4 Figure 6)
G	Max Uplink RSSI-dependent noise limit testing - A 50 Ohm Termination is connected to the CU antenna port. A signal is connected to a step attenuator and then applied to the NU antenna port. Output is monitored from antenna port of NU. (refer to 1.4.4 Figure 7)
H	Max Downlink RSSI-dependent noise limit testing - A 50 Ohm Termination is connected to the CU antenna port. A signal is connected to a step attenuator and then applied to the NU antenna port. Output is monitored from antenna port of CU. (refer to 1.4.4 Figure 8)

#### 1.4.5 EUT Exercise Software

Manufacturer provided Nextivity Chart Interface v2.0.0.16 running from a support laptop where both NU and CU are connected via USB.

#### 1.4.6 Support Equipment and I/O cables

Manufacturer	Equipment/Cable	Description
Dell	Support Laptop	M/N: Latitude D630 PP18L S/N: 5SBJBG1
Dell	Support Laptop AC Adapter	M/N: PA-1900-02D S/N: 5SBJBG1
Nextivity	Support USB cable x 2	Custom 1.0 meter shielded USB Type A to Type A cable



FCC ID: NU: YETQ44-1M34CNU and CU: YETQ41-RECU  
 IC: NU: 9892A-Q441M34CNU and CU: 9892A-Q41RECU

Nextivity	Support USB cable x 2	Custom 1.0 meter shielded USB Type A to Micro B cable
Nextivity	USB / Interface Box x 2	Unshielded with "Tag-Connect" interface
Agilent	ESG Vector Signal Generator	M/N: E4438C S/N: MY49071335
Rhode & Schwarz	Support Wideband Radio Communication Tester	M/N: CMW500, S/N: 1201.0002K50/103829
Ramsey	Support Shielded Test Enclosure	With custom USB cable
Agilent	110 dB Step Attenuator	M/N: 8496B S/N: MY42143874
Agilent	11 dB Step Attenuator	M/N: 8494B S/N: 2812A17193
Rhode & Schwarz	Step Attenuator	M/N: RSP S/N: 834500/009
Mini-Circuits	Power Splitter	M/N ZN2PD-63-S+ S/N UU74001429
RF Precision Cables, Inc.	Power Splitter	M/N: PDX2103
Weinschel	Power Splitter	M/N: 1506A S/N: RR002

1.4.7 Simplified Test Configuration Diagram

Figure 1 – Test configuration in EUT normal operational mode

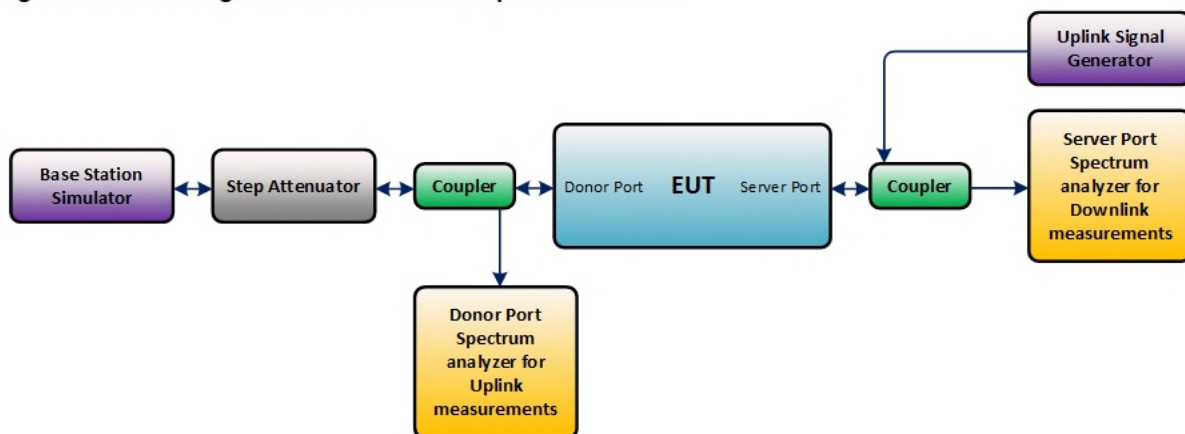



FCC ID: NU: YETQ44-1M34CNU and CU: YETQ41-RECU  
IC: NU: 9892A-Q441M34CNU and CU: 9892A-Q41RECU

**Figure 2 – Uplink test configuration in EUT test mode**



**Figure 3 – Downlink test configuration in EUT test mode**



**Figure 5 – Intermodulation product instrumentation test setup**

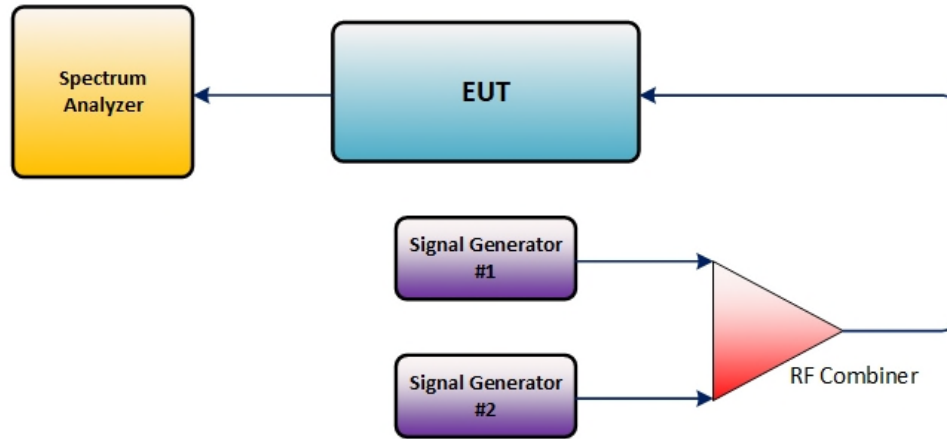

**Figure 6 – Maximum downlink noise limit test configuration**





FCC ID: NU: YETQ44-1M34CNU and CU: YETQ41-RECU  
 IC: NU: 9892A-Q441M34CNU and CU: 9892A-Q41RECU

**Figure 7 – Uplink RSSI-dependent noise limit test configuration**

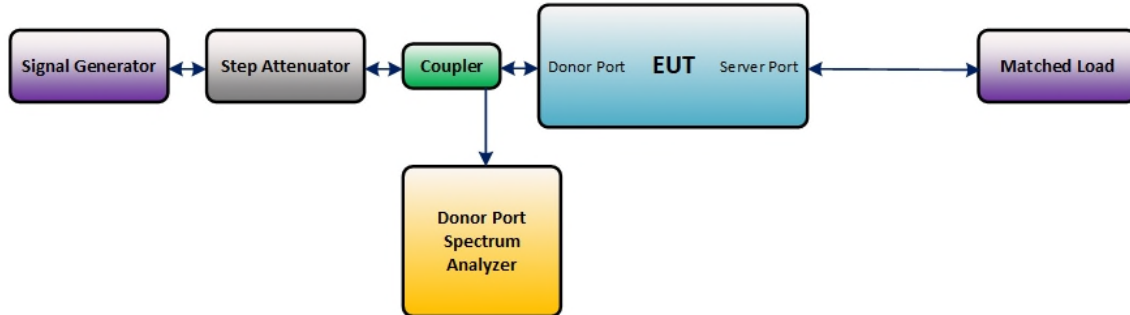

**Figure 8 – Downlink RSSI-dependent noise limit test configuration**

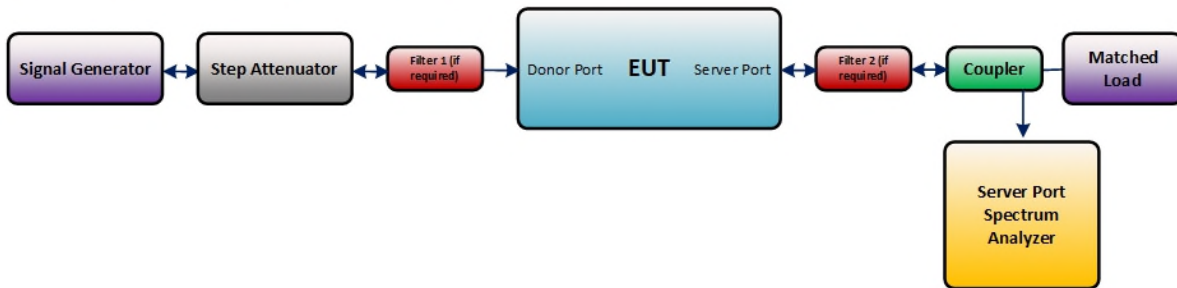

**1.5 Deviations from the Standard**

There were no deviations made during testing from the applicable test standard or test plan.

**1.6 EUT Modification Record**

The table below details modifications made to the EUT during the test program. The modifications incorporated during each test are recorded on the appropriate test pages.

Modification State	Description of Modification still fitted to EUT	Modification Fitted By	Date Modification Fitted
0	As supplied by the manufacturer	-	-

**1.7 Test Methods**

All measurements contained in this report were conducted as per KDB935210 D04 Provider-Specific Consumer Signal Boosters Compliance Measurements Guidance (February 12, 2016).



FCC ID: NU: YETQ44-1M34CNU and CU: YETQ41-RECU  
IC: NU: 9892A-Q441M34CNU and CU: 9892A-Q41RECU

## 1.8 Test Location

TÜV SÜD America conducted the following tests at our San Diego CA, Test Laboratory's.

Office Address:

### **TÜV SÜD America Inc. (Mira Mesa)**

10040 Mesa Rim Road, San Diego, CA 92121-2912 (32.901268,-117.177681).  
Phone: (858) 678 1400 Fax: (858) 546 0364.

### **TÜV SÜD America Inc. (Rancho Bernardo)**

16936 Via Del Campo, San Diego, CA 92127-1708 (33.018644,-117.092409).  
Phone: (858) 678 1400 Fax: (858) 546 0364.

## 1.9 Test Facility Registration

### 1.9.1 FCC – Designation No.: US1146

TÜV SÜD America Inc. (San Diego), is an accredited test facility with the site description report on file and has met all the requirements specified in §2.948 of the FCC rules. The acceptance letter from the FCC is maintained in our files and the Designation is US1146.

### 1.9.2 Innovation, Science and Economic Development Canada (ISED) Registration No.: 3067A-1 & 22806-1

The 10m Semi-anechoic chamber of TÜV SÜD America Inc. (San Diego Rancho Bernardo) has been registered by Certification and Engineering Bureau of Innovation, Science and Economic Development Canada for radio equipment testing with Registration No. 3067A-1.

The 3m Semi-anechoic chamber of TÜV SÜD America Inc. (San Diego Mira Mesa) has been registered by Certification and Engineering Bureau of Innovation, Science and Economic Development Canada for radio equipment testing with Registration No. 22806-1.

### 1.9.3 BSMI – Laboratory Code: SL2-IN-E-028R (US0102)

TÜV Product Service Inc. (San Diego) is a recognized RADIO testing laboratory by the BSMI under the MRA (Mutual Recognition Arrangement) with the United States. Accreditation includes CNS 13438 up to 6GHz.

### 1.9.4 NCC (National Communications Commission - US0102)

TÜV SÜD America Inc. (San Diego) is listed as a Foreign Recognized Telecommunication Equipment Testing Laboratory and is accredited to ISO/IEC 17025 (A2LA Certificate No.2955.13) which under APEC TEL MRA Phase 1 was designated as a Conformity Assessment Body competent to perform testing of equipment subject to the Technical Regulations covered under its scope of accreditation including RTTE01, PLMN01 and PLMN08 for TTE type of testing and LP0002 for Low-Power RF Device type of testing.





FCC ID: NU: YETQ44-1M34CNU and CU: YETQ41-RECU  
IC: NU: 9892A-Q441M34CNU and CU: 9892A-Q41RECU

**1.9.5 VCCI – Registration No. A-0280 and A-0281**

TÜV SÜD America Inc. (San Diego) is a VCCI registered measurement facility which includes radiated field strength measurement, radiated field strength measurement above 1GHz, mains port interference measurement and telecommunication port interference measurement.

**1.9.6 RRA – Identification No. US0102**

TÜV SÜD America Inc. (San Diego) is National Radio Research Agency (RRA) recognized laboratory under Phase I of the APEC Tel MRA.

**1.9.7 OFCA – U.S. Identification No. US0102**

TÜV SÜD America Inc. (San Diego) is recognized by Office of the Communications Authority (OFCA) under Appendix B, Phase I of the APEC Tel MRA.



FCC ID: NU: YETQ44-1M34CNU and CU: YETQ41-RECU  
IC: NU: 9892A-Q441M34CNU and CU: 9892A-Q41RECU

## 2 Test Details

### 2.1 Authorized Frequency Band Verification

#### 2.1.1 Specification Reference

FCC 47 CFR Part 20, Clause 20.21 (e)(3)  
KDB935210 D04, Clause 7.1

#### 2.1.2 Standard Applicable

FCC 47 CFR Part 20, Clause 20.21 (e)(3) Frequency Bands:  
Consumer Signal Boosters must be designed and manufactured such that they only operate on the frequencies used for the provision of subscriber-based services under parts 22 (Cellular), 24 (Broadband PCS), 27 (AWS-1, 700 MHz Lower A-E Blocks, and 700 MHz Upper C Block), and 90 (Specialized Mobile Radio) of this chapter. The Commission will not certificate any Consumer Signal Boosters for operation on part 90 of this chapter (Specialized Mobile Radio) frequencies until the Commission releases a public notice announcing the date Consumer Signal Boosters may be used in the band

#### 2.1.3 Equipment Under Test and Modification State

Serial No: 370920000139 (NU)and 371929000156 (CU) / Test Configuration A and B

#### 2.1.4 Date of Test/Initial of test personnel who performed the test

August 02, 05, 08 and October 15, 16, 2019 /XYZ

#### 2.1.5 Test Equipment Used

The major items of test equipment used for the above tests are identified in Section 3.1.

#### 2.1.6 Environmental Conditions

Test performed at TÜV SÜD America Inc. Mira Mesa facility.

Ambient Temperature	24.5 - 27.0°C
Relative Humidity	39.1 - 51.5%
ATM Pressure	98.5 - 99.0kPa



FCC ID: NU: YETQ44-1M34CNU and CU: YETQ41-RECU  
 IC: NU: 9892A-Q441M34CNU and CU: 9892A-Q41RECU

**2.1.7 Additional Observations**

- This is conducted Test. Test procedure is per Section 7.1.1 of KDB935210 (D04 Provider Specific Booster Measurements v02r03). Appropriate offset (line losses) applied.
- The EUT operated in Test Mode, with the gain set to the maximum gain and a minimum bandwidth setting (5MHz).
- Setup the EUT according to Figure 2 or 3 of Section 6.3.3 of KDB935210 as appropriate.
- Evaluations are conducted at CU and NU antenna ports.
- Both downlink and uplink bands for WCDMA Band 5 and LTE Band 4, 12, 13, 25 on CU and NU all four antenna ports A, B, C, D were tested.
- The signal generator was set to transmit a 5MHz WCDMA or 5MHz LTE signal.
- Frequency Range:

Technology	Band	DL Frequency Range (MHz)	UL Frequency Range (MHz)
WCDMA	5	869 - 894	824 - 849
LTE	4	2110 - 2155	1710 - 1755
LTE	12	729 – 746	699 – 716
LTE	13	746 - 756	777 - 787
LTE	25	1930 - 1995	1850 - 1915



FCC ID: NU: YETQ44-1M34CNU and CU: YETQ41-RECU  
 IC: NU: 9892A-Q441M34CNU and CU: 9892A-Q41RECU

2.1.8 Test Results

WCDMA Band 5 Downlink Authorized Frequency Range (869 - 894MHz) – CU with NU Port A

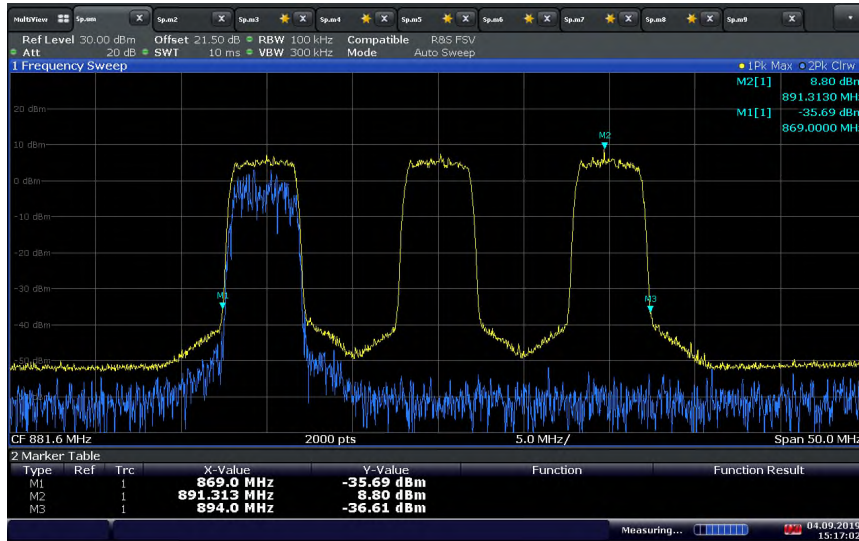

15:17:02 04.09.2019

WCDMA Band 5 Uplink Authorized Frequency Range (824 – 849 MHz) - NU Port A

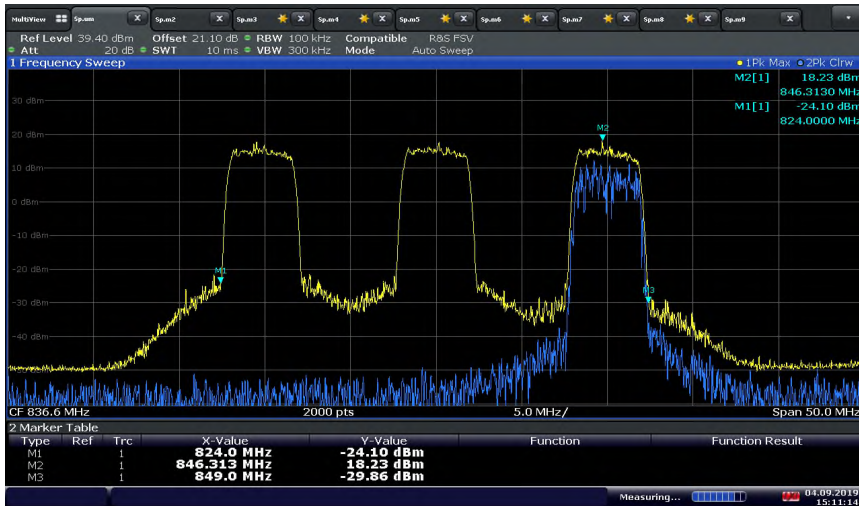

15:11:14 04.09.2019



FCC ID: NU: YETQ44-1M34CNU and CU: YETQ41-RECU  
 IC: NU: 9892A-Q441M34CNU and CU: 9892A-Q41RECU

**LTE Band 4 Downlink Authorized Frequency Range (2110 – 2155 MHz) - CU with NU Port A**

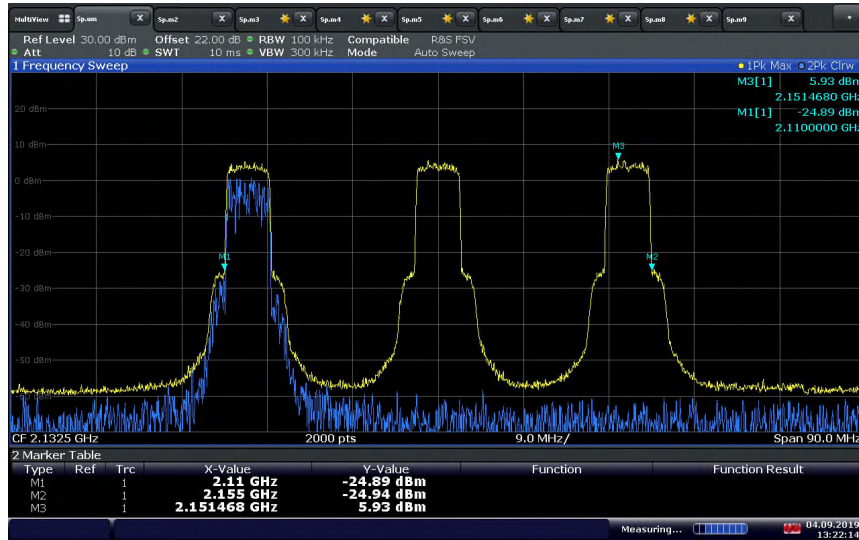

13:22:15 04.09.2019

**LTE Band 4 Uplink Authorized Frequency Range (1710 – 1755 MHz) - NU Port A**

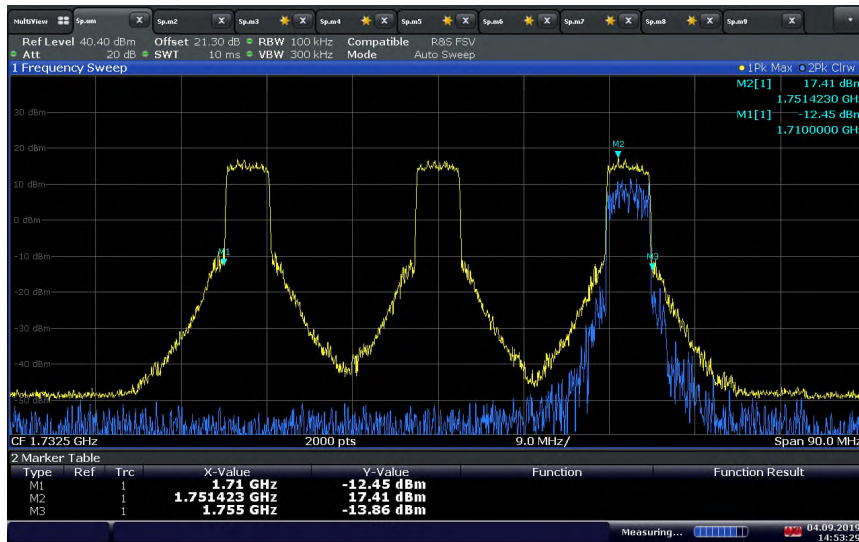

14:53:29 04.09.2019



FCC ID: NU: YETQ44-1M34CNU and CU: YETQ41-RECU  
 IC: NU: 9892A-Q441M34CNU and CU: 9892A-Q41RECU

**LTE Band 4 Downlink Authorized Frequency Range (2110 – 2155 MHz) - CU with NU Port B**

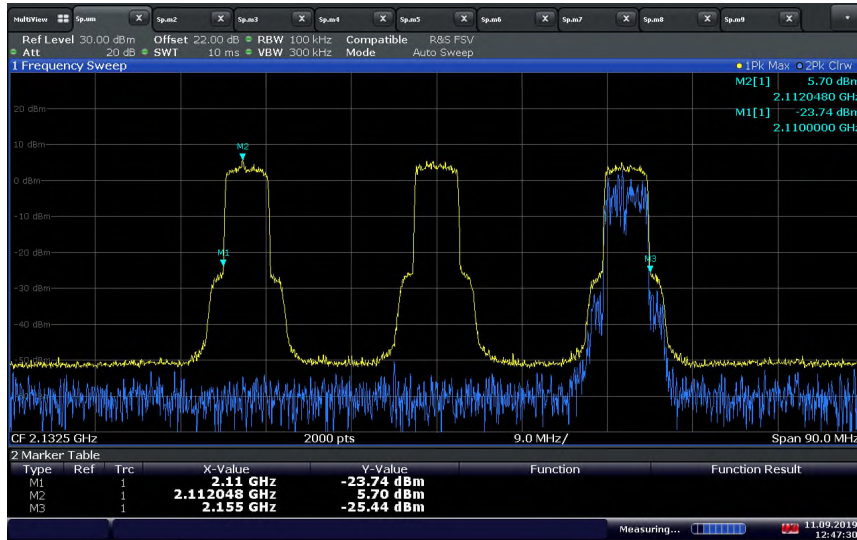

12:47:31 11.09.2019

**LTE Band 4 Uplink Authorized Frequency Range (1710 – 1755 MHz) - NU Port B**

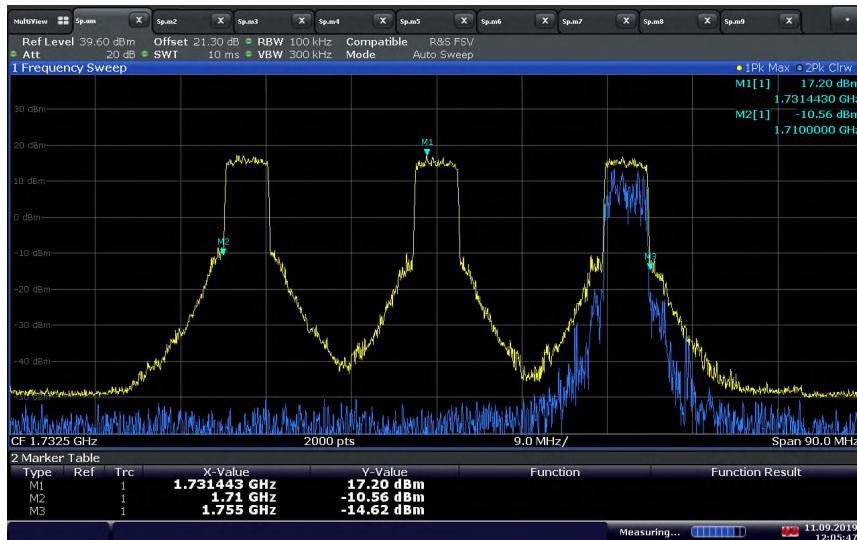

12:05:47 11.09.2019



FCC ID: NU: YETQ44-1M34CNU and CU: YETQ41-RECU  
 IC: NU: 9892A-Q441M34CNU and CU: 9892A-Q41RECU

**LTE Band 4 Downlink Authorized Frequency Range (2110 – 2155 MHz) - CU with NU Port C**

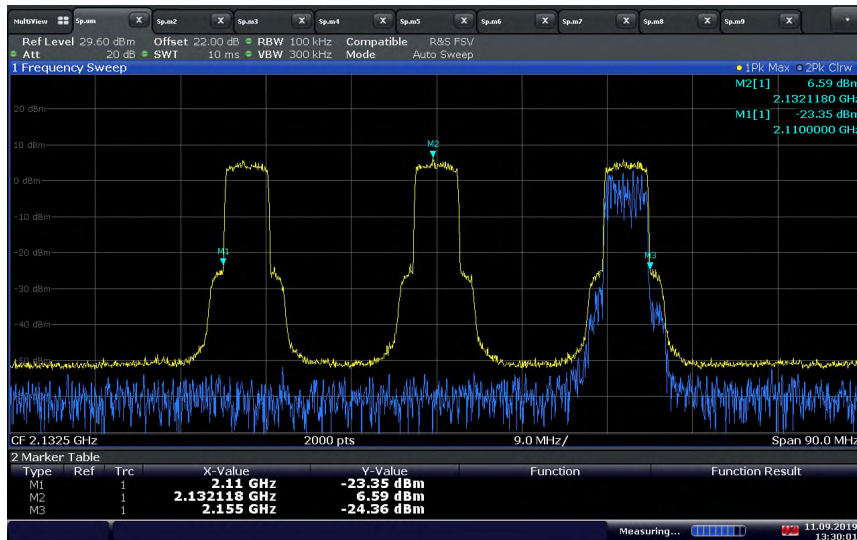

13:30:01 11.09.2019

**LTE Band 4 Uplink Authorized Frequency Range (1710 – 1755 MHz) - NU Port C**

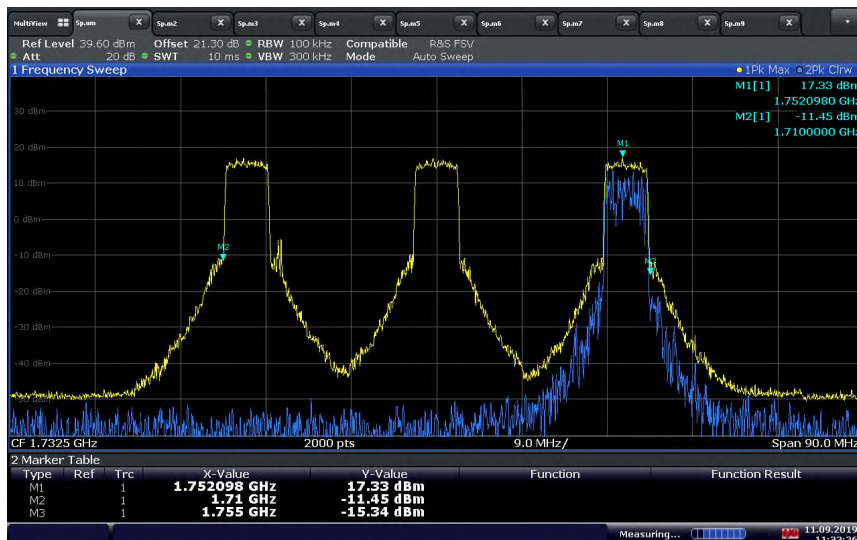

11:32:27 11.09.2019



FCC ID: NU: YETQ44-1M34CNU and CU: YETQ41-RECU  
 IC: NU: 9892A-Q441M34CNU and CU: 9892A-Q41RECU

**LTE Band 12 Downlink Authorized Frequency Range (729 – 746 MHz) - CU with NU Port A**

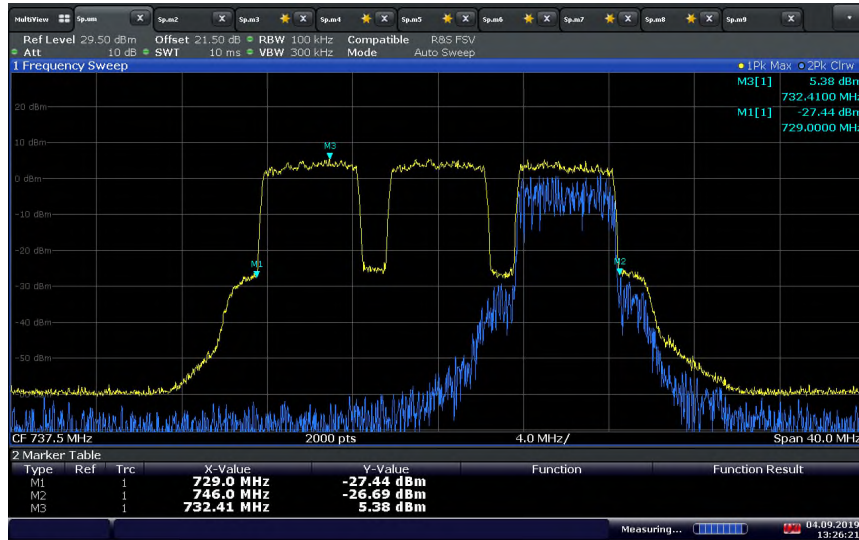

13:26:22 04.09.2019

**LTE Band 12 Uplink Authorized Frequency Range (699 – 716 MHz) - NU Port A**

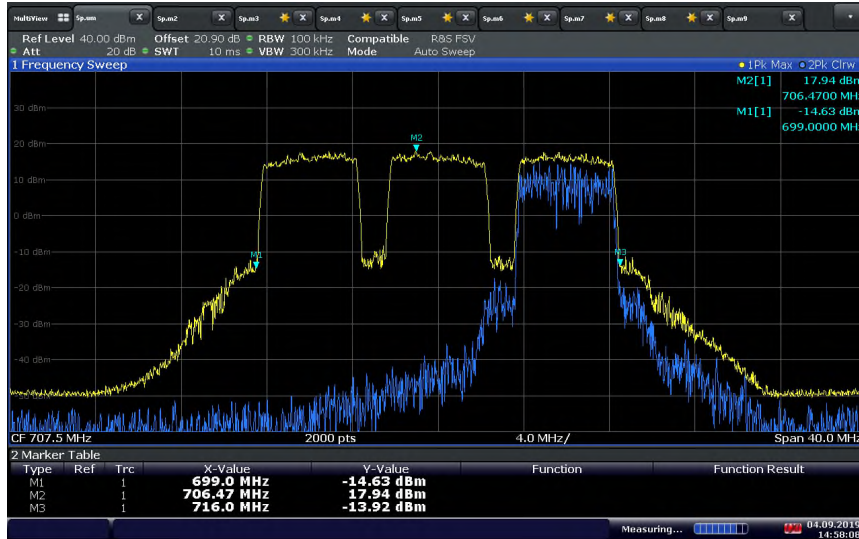

14:58:08 04.09.2019





FCC ID: NU: YETQ44-1M34CNU and CU: YETQ41-RECU  
 IC: NU: 9892A-Q441M34CNU and CU: 9892A-Q41RECU

**LTE Band 12 Downlink Authorized Frequency Range (729 – 746 MHz) - CU with NU Port B**

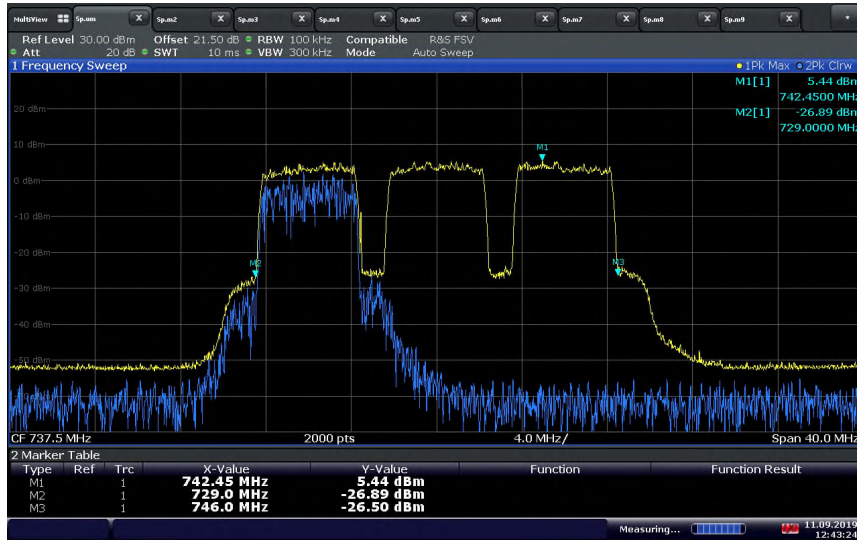

12:43:25 11.09.2019

**LTE Band 12 Uplink Authorized Frequency Range (699 – 716 MHz) - NU Port B**

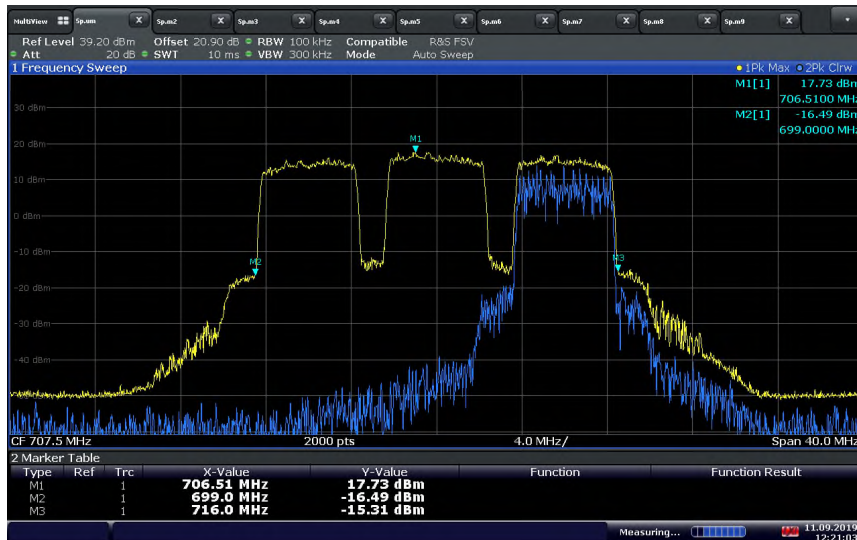

12:21:04 11.09.2019



FCC ID: NU: YETQ44-1M34CNU and CU: YETQ41-RECU  
 IC: NU: 9892A-Q441M34CNU and CU: 9892A-Q41RECU

**LTE Band 13 Downlink Authorized Frequency Range (746 – 756 MHz) - CU with NU Port C**

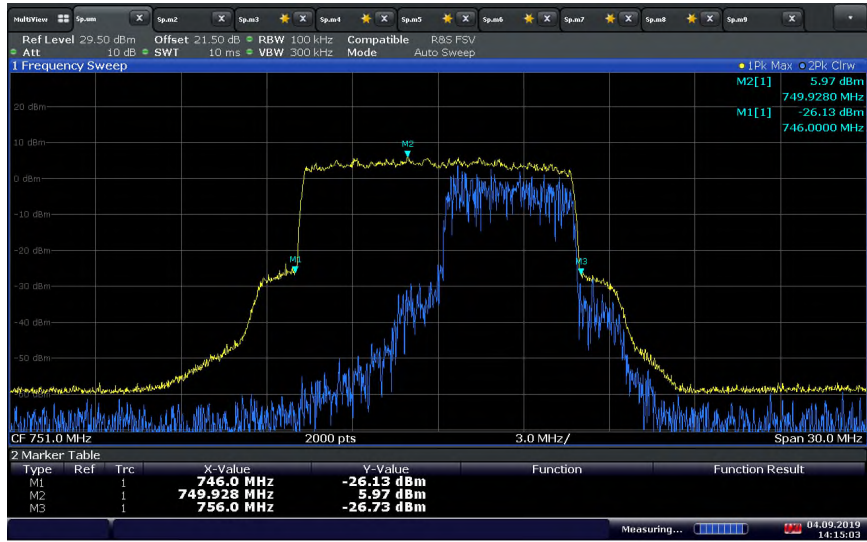

14:15:03 04.09.2019

**LTE Band 13 Uplink Authorized Frequency Range (777 – 787 MHz) - NU Port C**

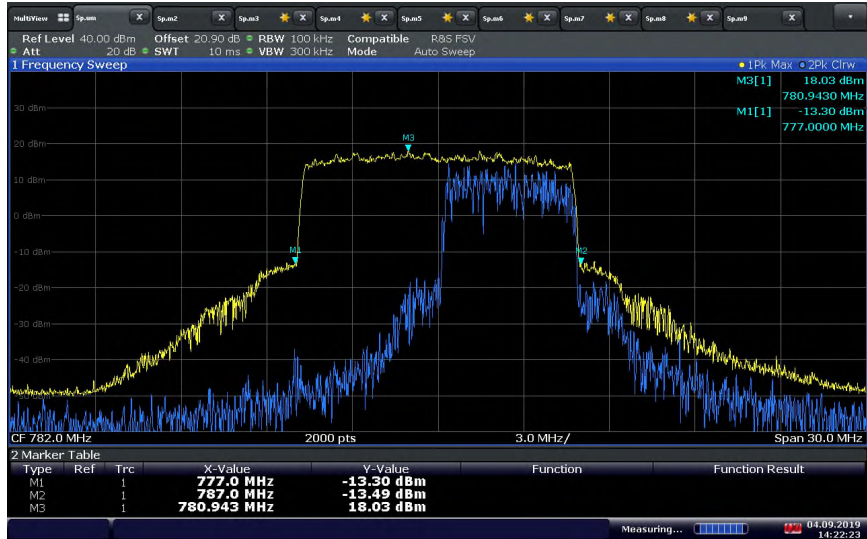

14:22:23 04.09.2019



FCC ID: NU: YETQ44-1M34CNU and CU: YETQ41-RECU  
 IC: NU: 9892A-Q441M34CNU and CU: 9892A-Q41RECU

**LTE Band 25 Downlink Authorized Frequency Range (1930 – 1995 MHz) - CU with NU Port A**

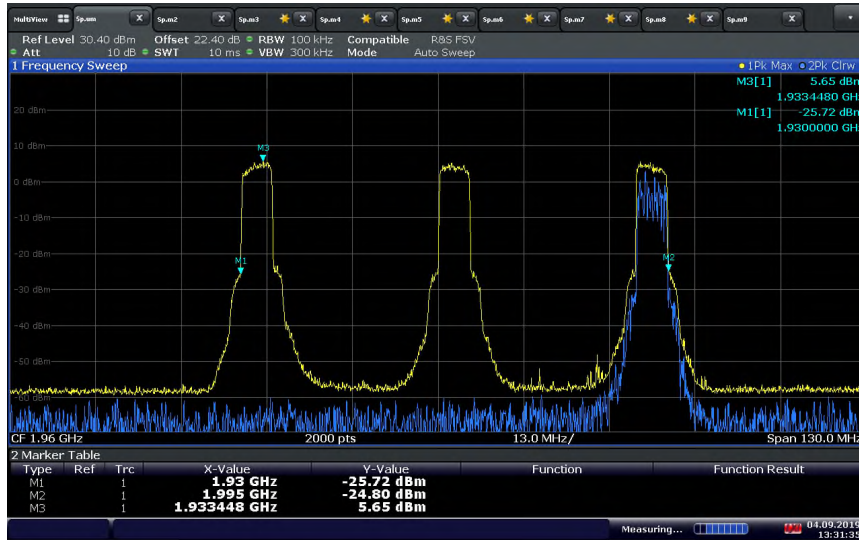

13:31:36 04.09.2019

**LTE Band 25 Uplink Authorized Frequency Range (1850 – 1915 MHz) - NU Port A**

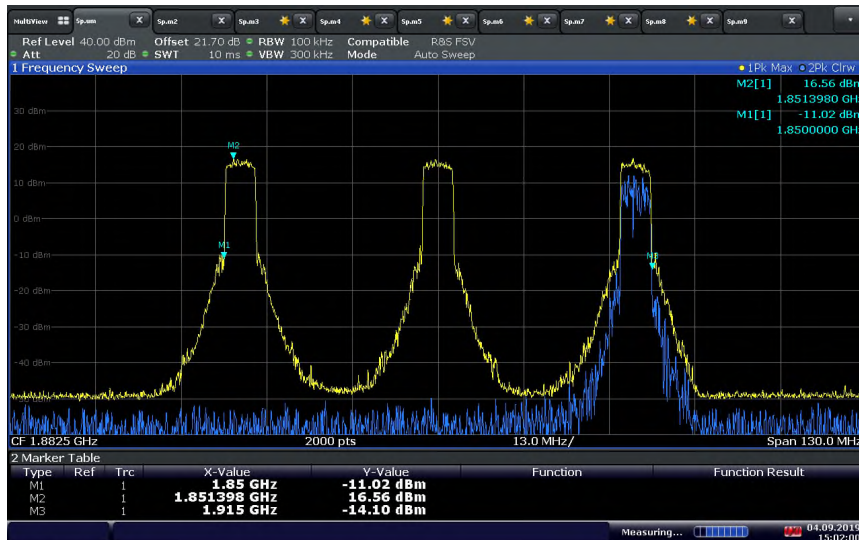

15:02:00 04.09.2019



FCC ID: NU: YETQ44-1M34CNU and CU: YETQ41-RECU  
 IC: NU: 9892A-Q441M34CNU and CU: 9892A-Q41RECU

**LTE Band 25 Downlink Authorized Frequency Range (1930 – 1995 MHz) - CU with NU Port B**

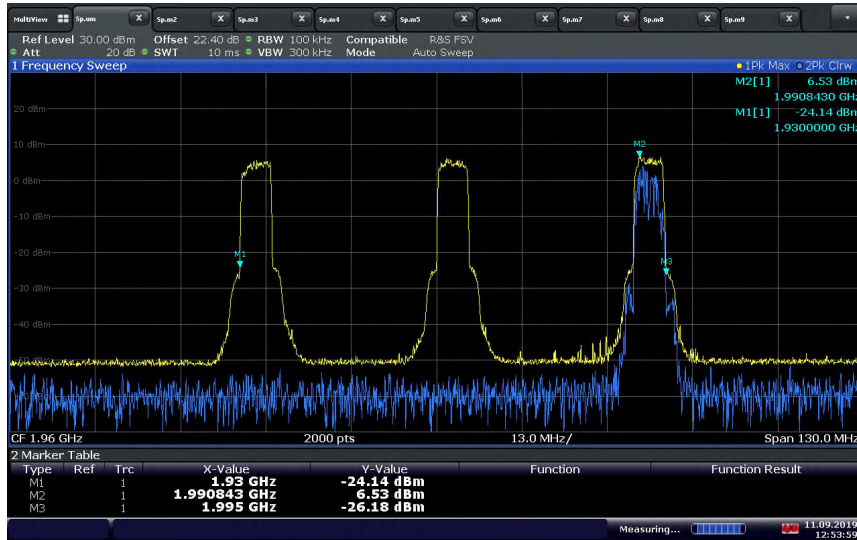

12:53:59 11.09.2019

**LTE Band 25 Uplink Authorized Frequency Range (1850 – 1915 MHz) - NU Port B**

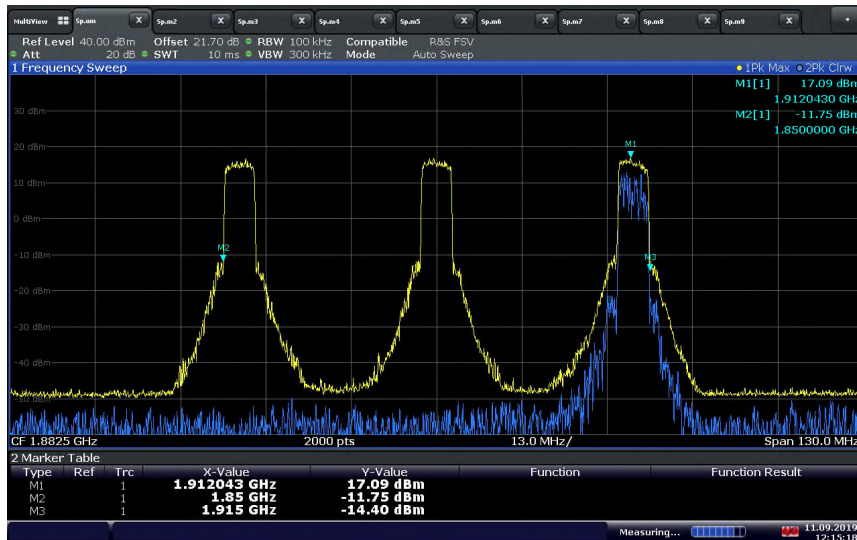

12:15:18 11.09.2019



FCC ID: NU: YETQ44-1M34CNU and CU: YETQ41-RECU  
 IC: NU: 9892A-Q441M34CNU and CU: 9892A-Q41RECU

**LTE Band 25 Downlink Authorized Frequency Range (1930 – 1995 MHz) - CU with NU Port C**

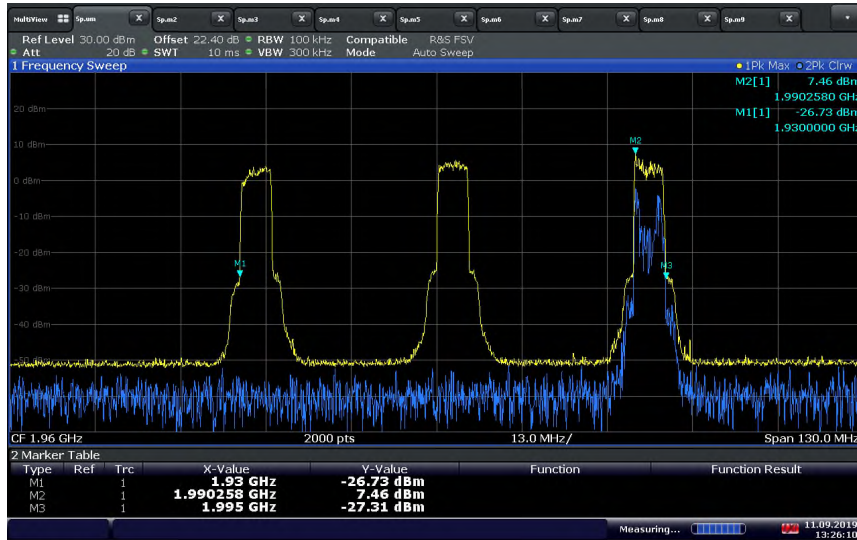

13:26:11 11.09.2019

**LTE Band 25 Uplink Authorized Frequency Range (1850 – 1915 MHz) - NU Port C**

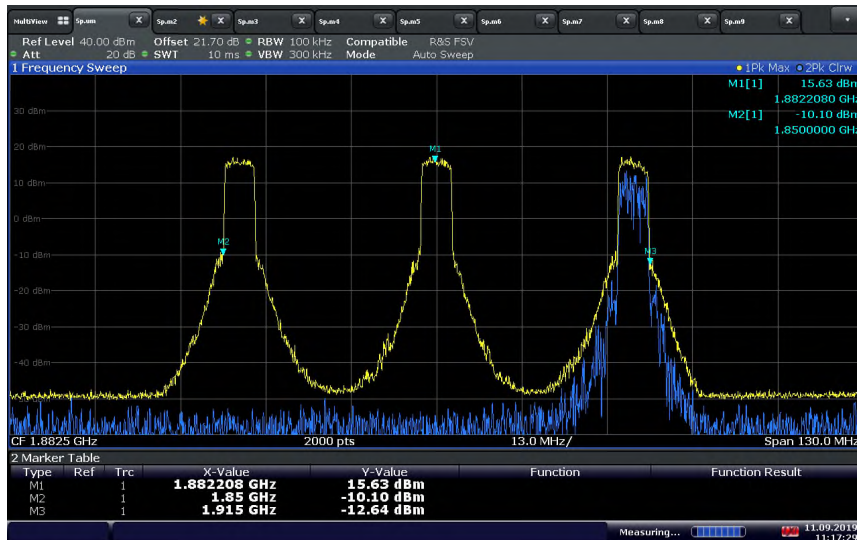

11:17:29 11.09.2019



FCC ID: NU: YETQ44-1M34CNU and CU: YETQ41-RECU  
 IC: NU: 9892A-Q441M34CNU and CU: 9892A-Q41RECU

**LTE Band 25 Downlink Authorized Frequency Range (1930 – 1995 MHz) - CU with NU Port D**

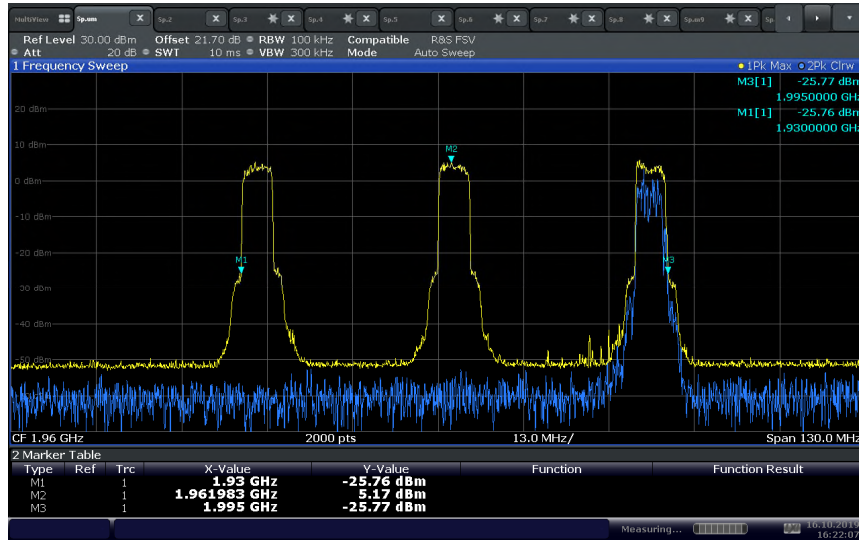

16:22:08 16.10.2019

**LTE Band 25 Uplink Authorized Frequency Range (1850 – 1915 MHz) - NU Port D**

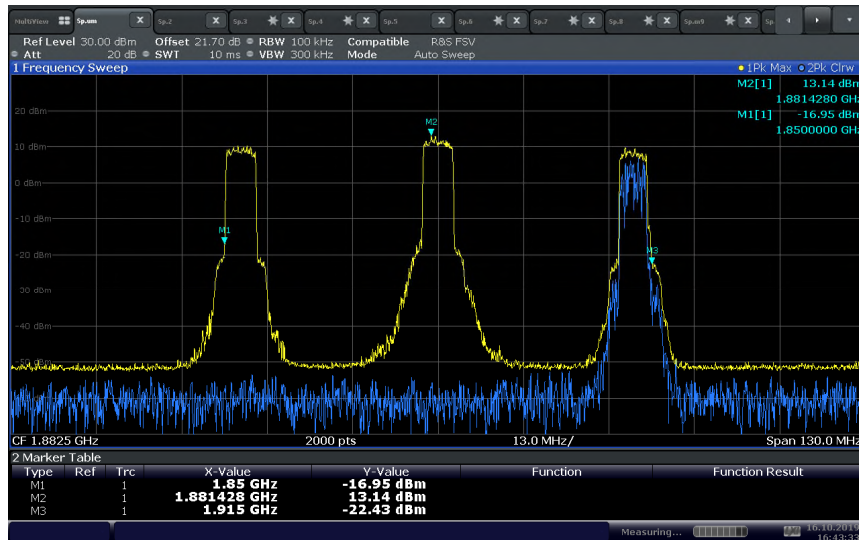

16:43:33 16.10.2019



FCC ID: NU: YETQ44-1M34CNU and CU: YETQ41-RECU  
IC: NU: 9892A-Q441M34CNU and CU: 9892A-Q41RECU

## **2.2 Authorized CMRS Provider**

### **2.2.1 Specification Reference**

FCC 47 CFR Part 27, Clause 27.50 (h)(1)  
FCC 47 CFR Part 27, Clause 27.50 (a)((1))  
RSS-139, Clause 6.5  
RSS-195, Clause 5.5

### **2.2.2 Standard Applicable**

FCC 47 CFR Part 20, Clause 20.21 (e)(3) Frequency Bands:  
Consumer Signal Boosters must be designed and manufactured such that they only operate on the frequencies used for the provision of subscriber-based services under parts 22 (Cellular), 24 (Broadband PCS), 27 (AWS-1, 700 MHz Lower A-E Blocks, and 700 MHz Upper C Block), and 90 (Specialized Mobile Radio) of this chapter. The Commission will not certificate any Consumer Signal Boosters for operation on part 90 of this chapter (Specialized Mobile Radio) frequencies until the Commission releases a public notice announcing the date Consumer Signal Boosters may be used in the band.

FCC 47 CFR Part 20, Clause 20.21(e)(4) Self Monitoring:  
Consumer Signal Boosters must automatically self-monitor their operation to ensure compliance with applicable noise and gain limits and either self-correct or shut down automatically if their operation exceeds those parameters.

### **2.2.1 Equipment Under Test and Modification State**

Serial No: 370920000139 (NU)and 371929000156 (CU) / Test Configuration A and B

### **2.2.2 Date of Test/Initial of test personnel who performed the test**

August 09, 12, 13, September 04 and October 15, 2019/XYZ

### **2.2.3 Test Equipment Used**

The major items of test equipment used for the above tests are identified in Section 3.1.

### **2.2.4 Environmental Conditions**

Test performed at TÜV SÜD America Inc. Mira Mesa facility.

Ambient Temperature	24.5 - 26.3°C
Relative Humidity	45.0 - 53.3%
ATM Pressure	98.8 - 99.0kPa

### **2.2.5 Additional Observations**

- This is conducted Test. Test procedure is per Section 7.1.2 of KDB935210 (D04 Provider Specific Booster Measurements v02r03). Appropriate offset (line losses) applied.



FCC ID: NU: YETQ44-1M34CNU and CU: YETQ41-RECU  
 IC: NU: 9892A-Q441M34CNU and CU: 9892A-Q41RECU

- The EUT operated in Normal Mode, with the gain set to the maximum gain and a minimum bandwidth setting (5MHz).
- Setup the EUT according to Figure 1 of Section 6.3.2 of KDB935210 with the Base Station Simulator transmitting an authorized CMRS provider signal to the booster.
- Evaluations are conducted at NU and CU antenna ports.
- All operational uplink and downlink bands for WCDMA Band 5, and LTE Band 4, 12, 13 on CU and NU all four antenna ports A, B, C, D were tested.
- The Base Station Simulator was set to transmit a 5MHz LTE or WCDMA signal.
- The authorized CMRS Provider IDs are:
  - Port A: 310-410
  - Port B: 310-260
  - Port C: 311-480
  - Port D: 311-490
- Two Non- authorized CMRS Provider signals for each band were verified.
- Frequency Range:

Technology	Band	DL Frequency Range (MHz)	UL Frequency Range (MHz)
WCDMA	5	869 - 894	824 - 849
LTE	4	2110 - 2155	1710 - 1755
LTE	12	729 - 746	699 - 716
LTE	13	746 - 756	777 - 787
LTE	25	1930 - 1995	1850 - 1915





FCC ID: NU: YETQ44-1M34CNU and CU: YETQ41-RECU  
IC: NU: 9892A-Q441M34CNU and CU: 9892A-Q41RECU

### 2.2.6 Test Results

#### WCDMA Band 5 Downlink Authorized Frequency Range (869 - 894MHz) – CU with NU Port A (MCC/MNC: 310-410)

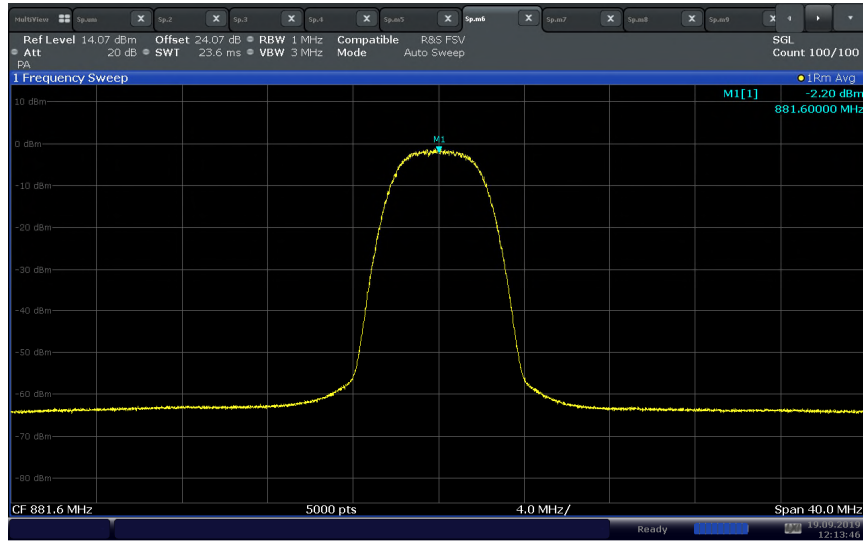

12:13:47 19.09.2019

#### WCDMA Band 5 Downlink Authorized Frequency Range (869 - 894MHz) – CU with NU Port A (MCC/MNC: 310-123)

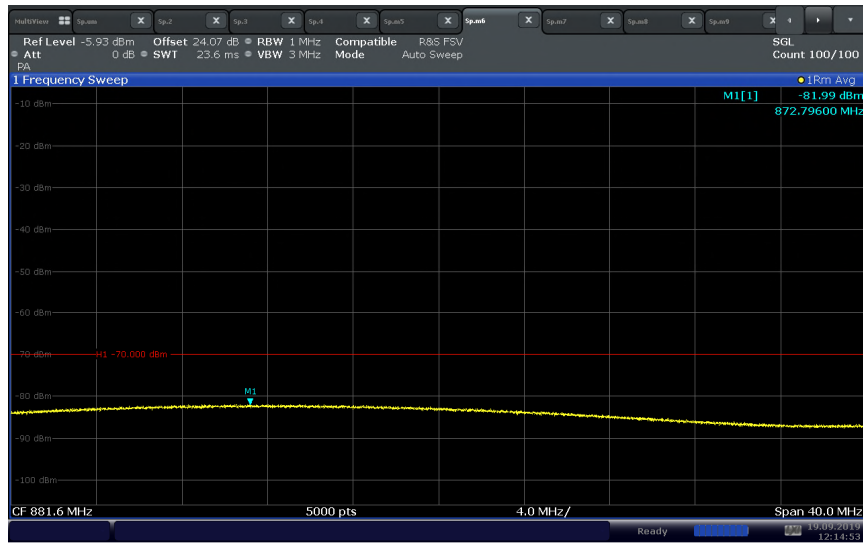

12:14:54 19.09.2019



FCC ID: NU: YETQ44-1M34CNU and CU: YETQ41-RECU  
IC: NU: 9892A-Q441M34CNU and CU: 9892A-Q41RECU

**WCDMA Band 5 Downlink Authorized Frequency Range (869 - 894MHz) – CU with NU Port A  
(MCC/MNC: 310-321)**

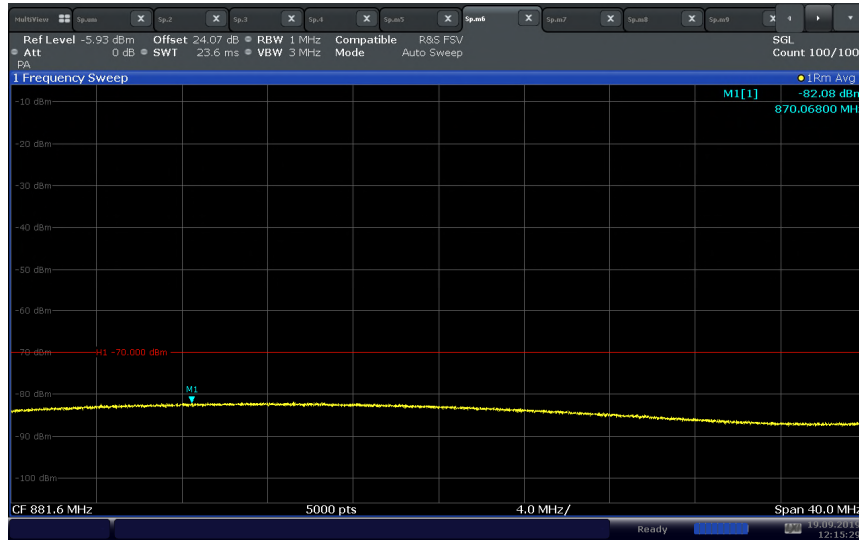

12:15:29 19.09.2019

**WCDMA Band 5 Uplink Authorized Frequency Range (824 – 849 MHz) – NU Port A  
(MCC/MNC: 310-410)**

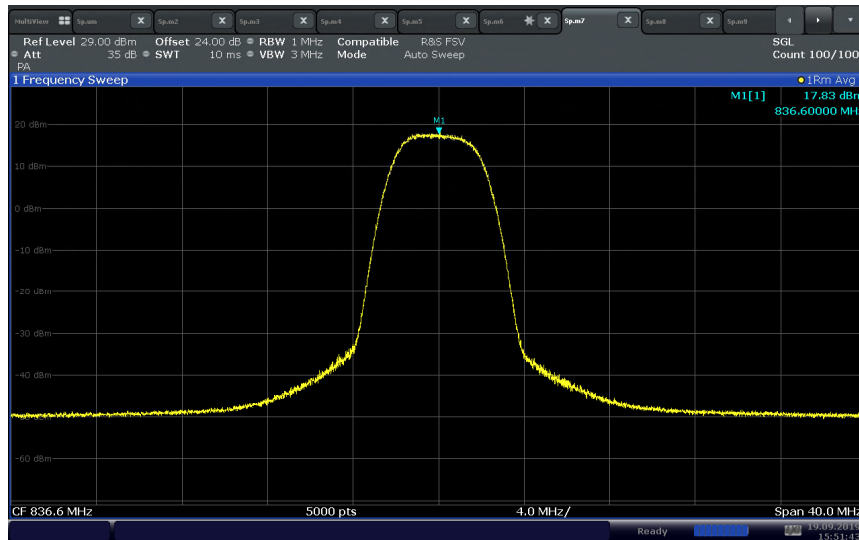

15:51:43 19.09.2019



FCC ID: NU: YETQ44-1M34CNU and CU: YETQ41-RECU  
IC: NU: 9892A-Q441M34CNU and CU: 9892A-Q41RECU

### WCDMA Band 5 Uplink Authorized Frequency Range (824 – 849 MHz) – NU Port A (MCC/MNC: 310-123)

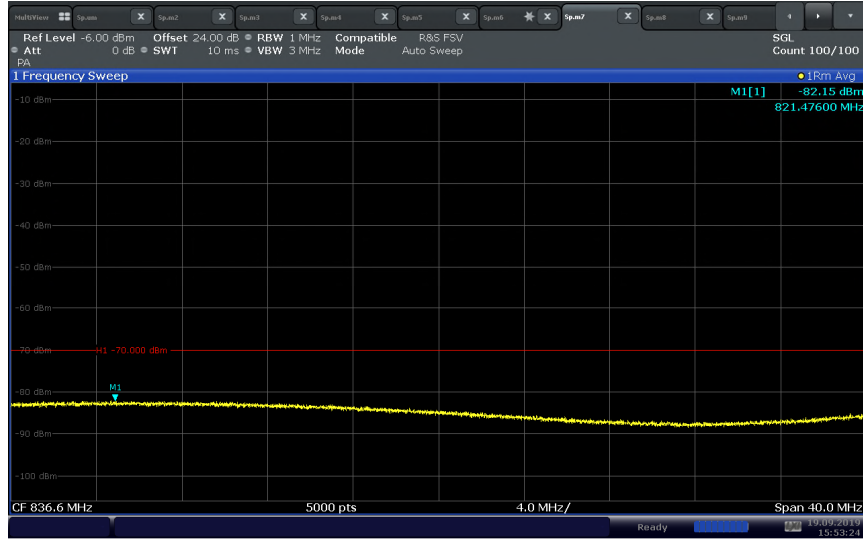

### WCDMA Band 5 Uplink Authorized Frequency Range (824 – 849 MHz) – NU Port A (MCC/MNC: 310-321)

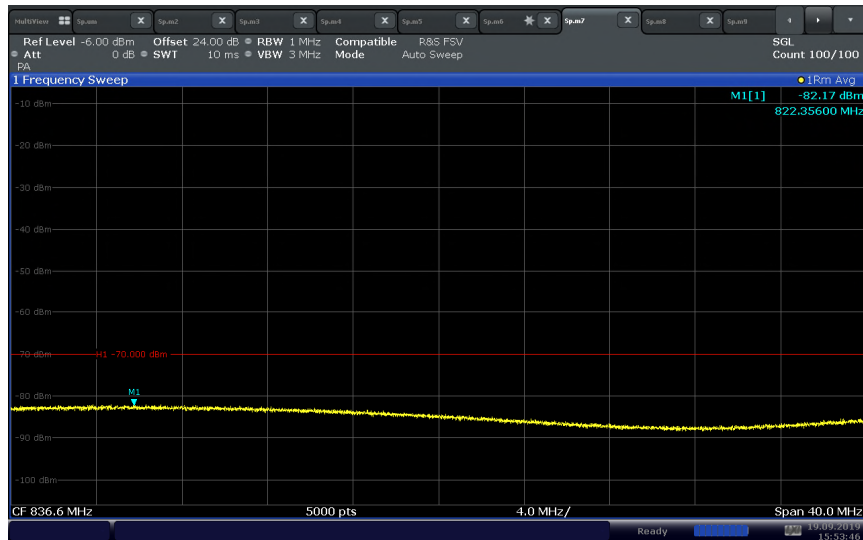



FCC ID: NU: YETQ44-1M34CNU and CU: YETQ41-RECU  
IC: NU: 9892A-Q441M34CNU and CU: 9892A-Q41RECU

**LTE Band 4 Downlink Authorized Frequency Range (2110 – 2155 MHz) – CU with NU Port A (MCC/MNC: 310-410)**

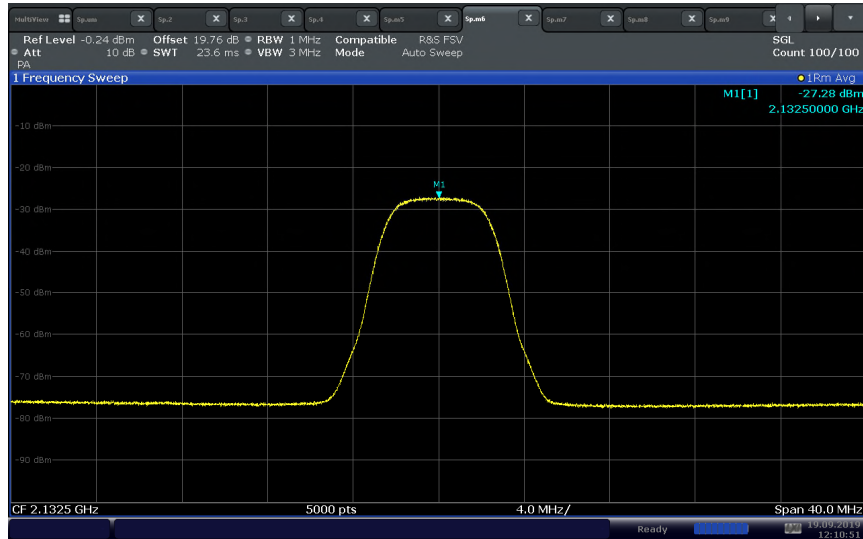

12:10:52 19.09.2019

**LTE Band 4 Downlink Authorized Frequency Range (2110 – 2155 MHz) – CU with NU Port A (MCC/MNC: 310-123)**

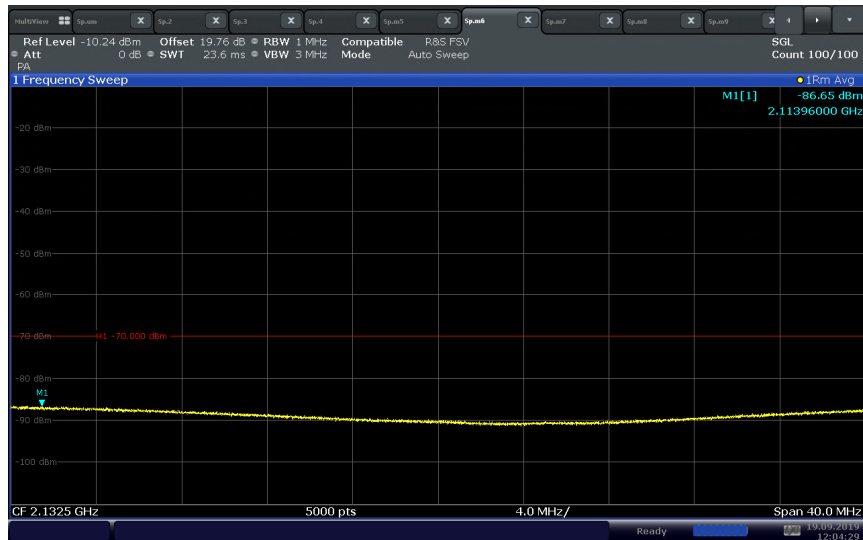

12:04:29 19.09.2019



FCC ID: NU: YETQ44-1M34CNU and CU: YETQ41-RECU  
IC: NU: 9892A-Q441M34CNU and CU: 9892A-Q41RECU

### LTE Band 4 Downlink Authorized Frequency Range (2110 – 2155 MHz) – CU with NU Port A (MCC/MNC: 310-321)

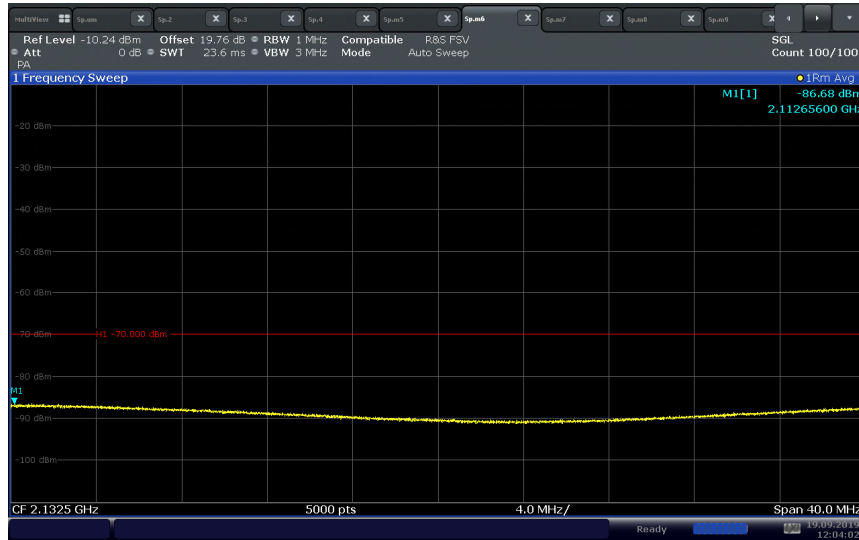

### LTE Band 4 Uplink Authorized Frequency Range (1710 – 1755 MHz) – NU Port A (MCC/MNC: 310-410)

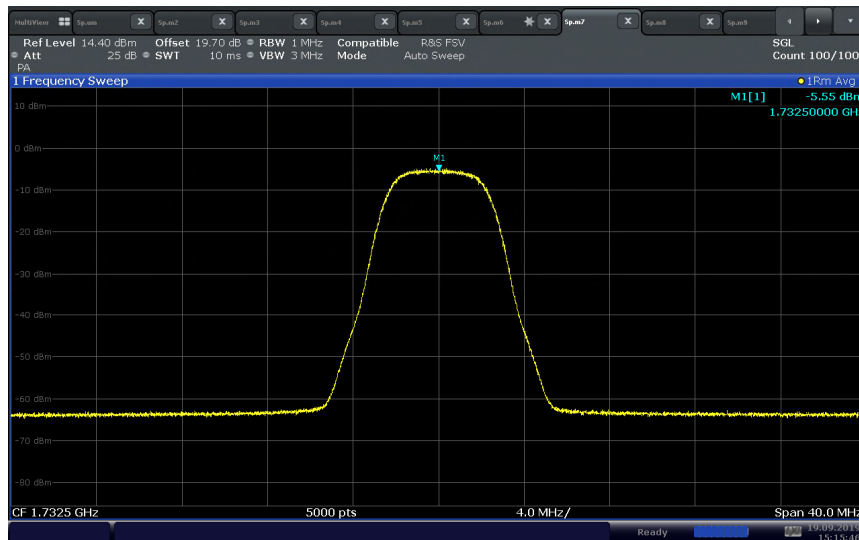



FCC ID: NU: YETQ44-1M34CNU and CU: YETQ41-RECU  
IC: NU: 9892A-Q441M34CNU and CU: 9892A-Q41RECU

### LTE Band 4 Uplink Authorized Frequency Range (1710 – 1755 MHz) – NU Port A (MCC/MNC: 310-123)

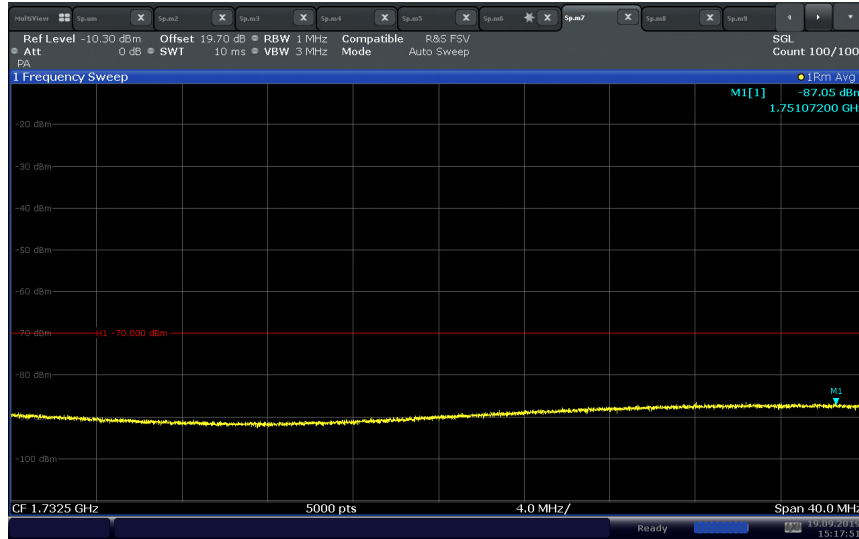

15:17:52 19.09.2019

### LTE Band 4 Uplink Authorized Frequency Range (1710 – 1755 MHz) – NU Port A (MCC/MNC: 310-321)

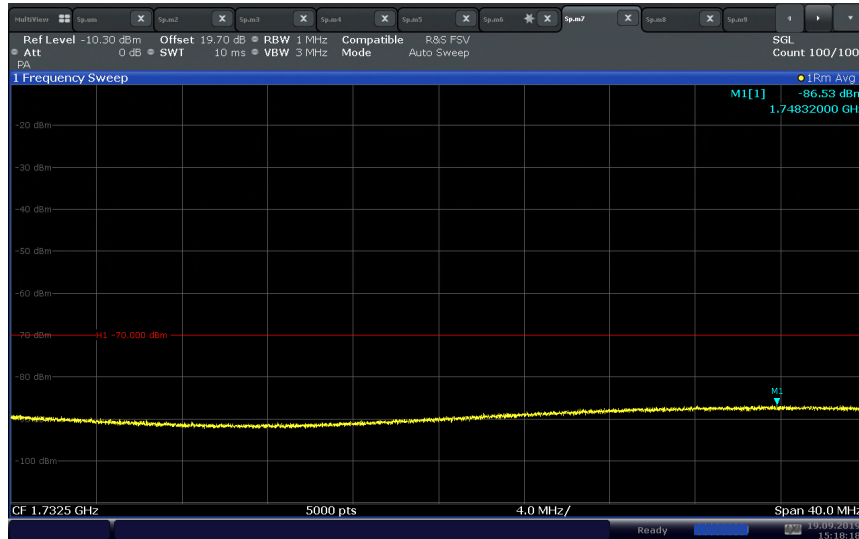

15:18:19 19.09.2019



FCC ID: NU: YETQ44-1M34CNU and CU: YETQ41-RECU  
IC: NU: 9892A-Q441M34CNU and CU: 9892A-Q41RECU

**LTE Band 4 Downlink Authorized Frequency Range (2110 – 2155 MHz) – CU with NU Port B (MCC/MNC: 310-260)**

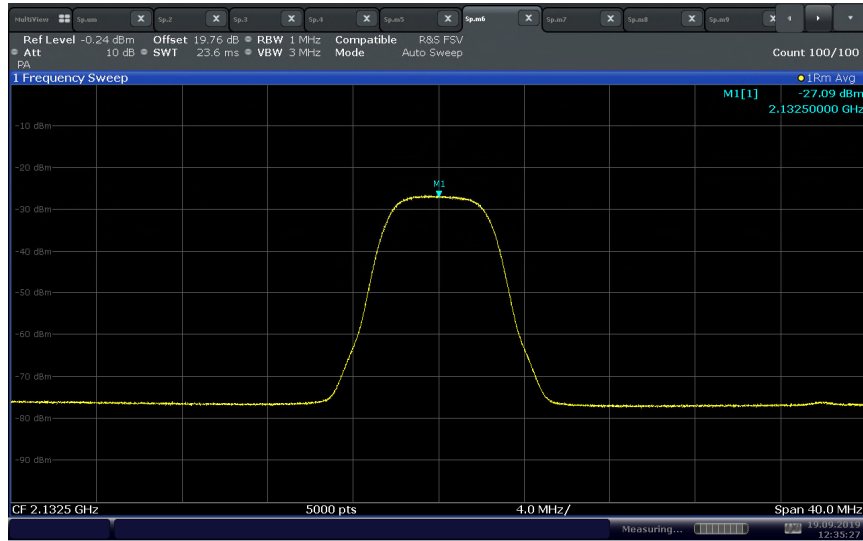

12:35:28 19.09.2019

**LTE Band 4 Downlink Authorized Frequency Range (2110 – 2155 MHz) – CU with NU Port B (MCC/MNC: 310-123)**

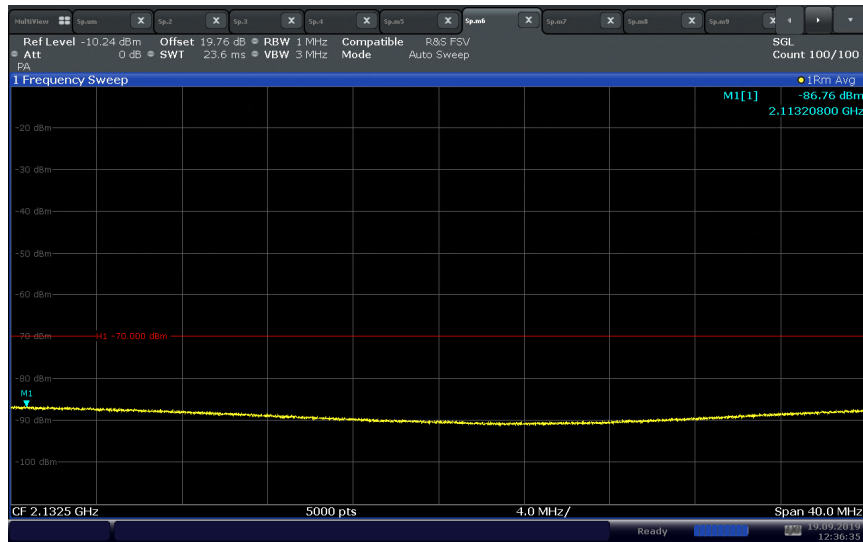

12:36:35 19.09.2019



FCC ID: NU: YETQ44-1M34CNU and CU: YETQ41-RECU  
IC: NU: 9892A-Q441M34CNU and CU: 9892A-Q41RECU

### LTE Band 4 Downlink Authorized Frequency Range (2110 – 2155 MHz) – CU with NU Port B (MCC/MNC: 310-321)

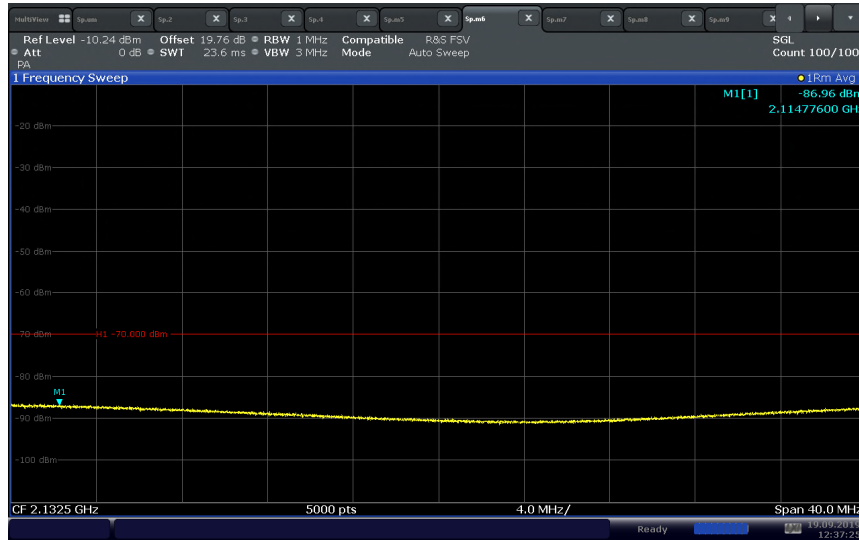

12:37:25 19.09.2019

### LTE Band 4 Uplink Authorized Frequency Range (1710 – 1755 MHz) – NU Port B (MCC/MNC: 310-260)

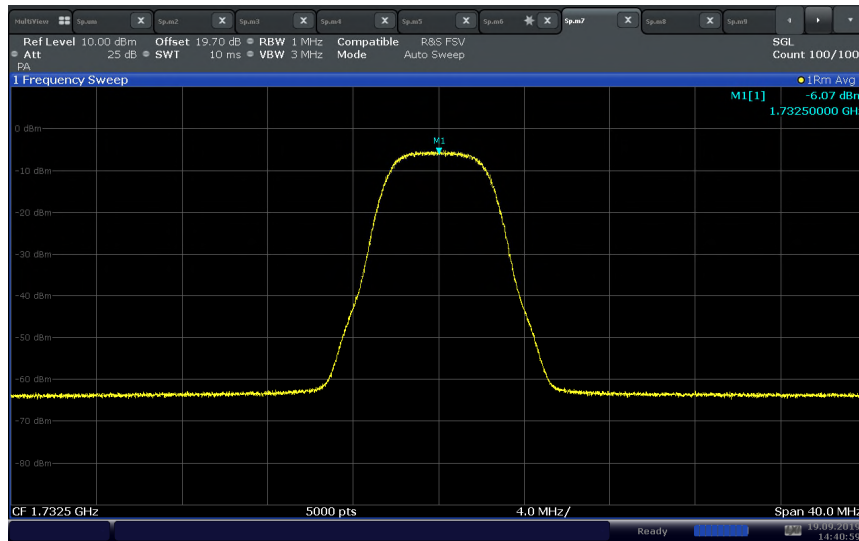

14:41:00 19.09.2019





FCC ID: NU: YETQ44-1M34CNU and CU: YETQ41-RECU  
IC: NU: 9892A-Q441M34CNU and CU: 9892A-Q41RECU

**LTE Band 4 Uplink Authorized Frequency Range (1710 – 1755 MHz) – NU Port B  
(MCC/MNC: 310-123)**

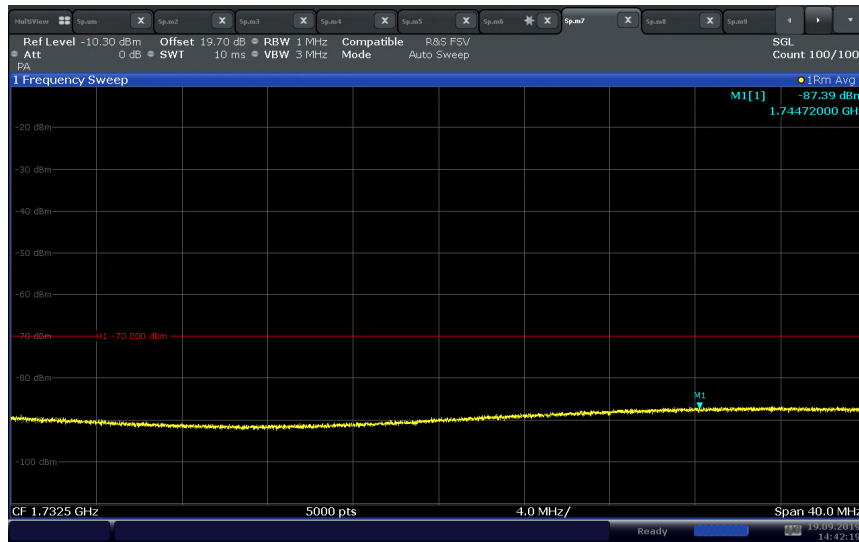

14:42:19 19.09.2019

**LTE Band 4 Uplink Authorized Frequency Range (1710 – 1755 MHz) – NU Port B  
(MCC/MNC: 310-321)**

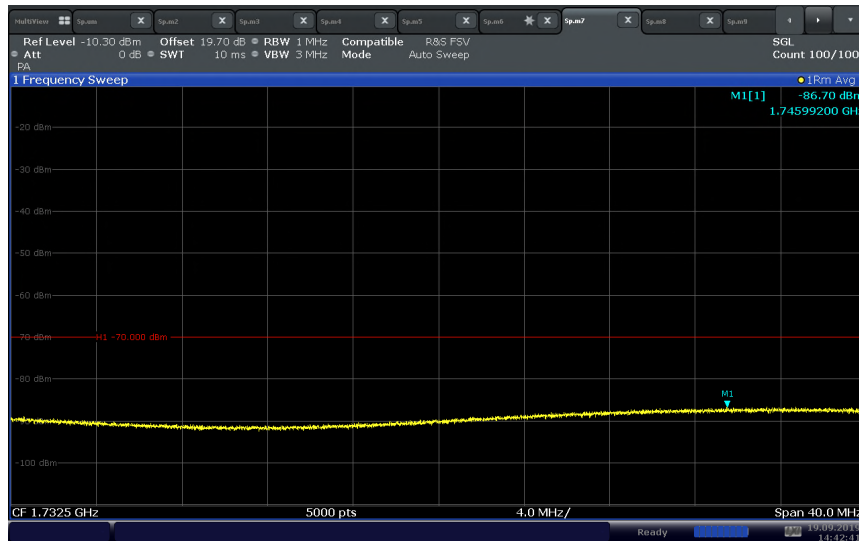

14:42:41 19.09.2019



FCC ID: NU: YETQ44-1M34CNU and CU: YETQ41-RECU  
IC: NU: 9892A-Q441M34CNU and CU: 9892A-Q41RECU

**LTE Band 4 Downlink Authorized Frequency Range (2110 – 2155 MHz) – CU with NU Port C (MCC/MNC: 311-480)**

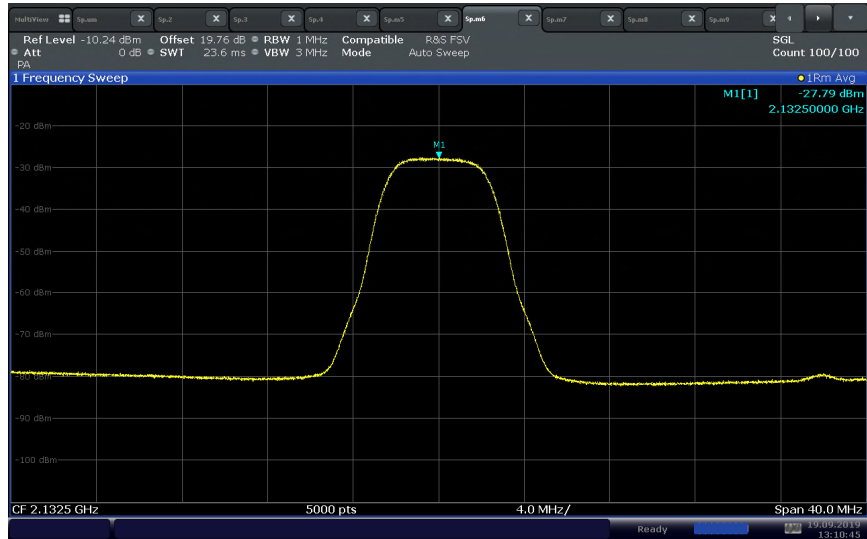

13:10:45 19.09.2019

**LTE Band 4 Downlink Authorized Frequency Range (2110 – 2155 MHz) – CU with NU Port C (MCC/MNC: 311-123)**

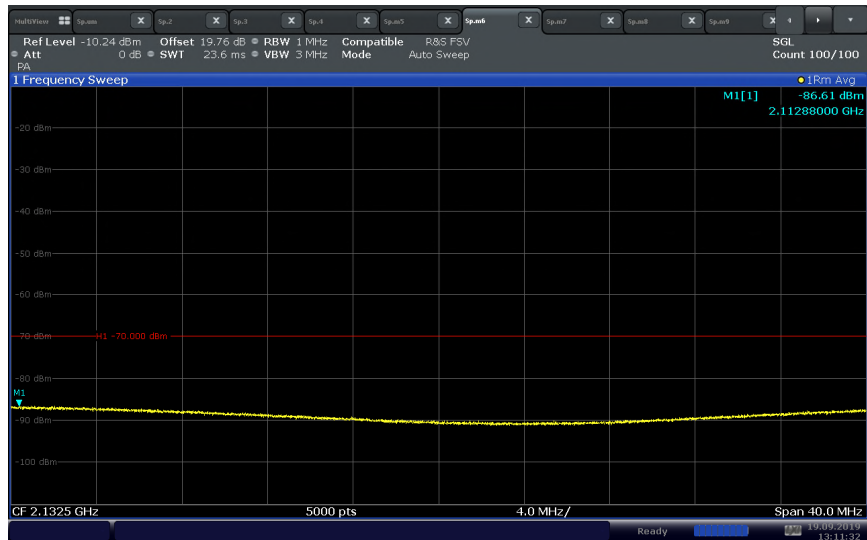

13:11:32 19.09.2019



FCC ID: NU: YETQ44-1M34CNU and CU: YETQ41-RECU  
IC: NU: 9892A-Q441M34CNU and CU: 9892A-Q41RECU

### LTE Band 4 Downlink Authorized Frequency Range (2110 – 2155 MHz) – CU with NU Port C (MCC/MNC: 311-321)

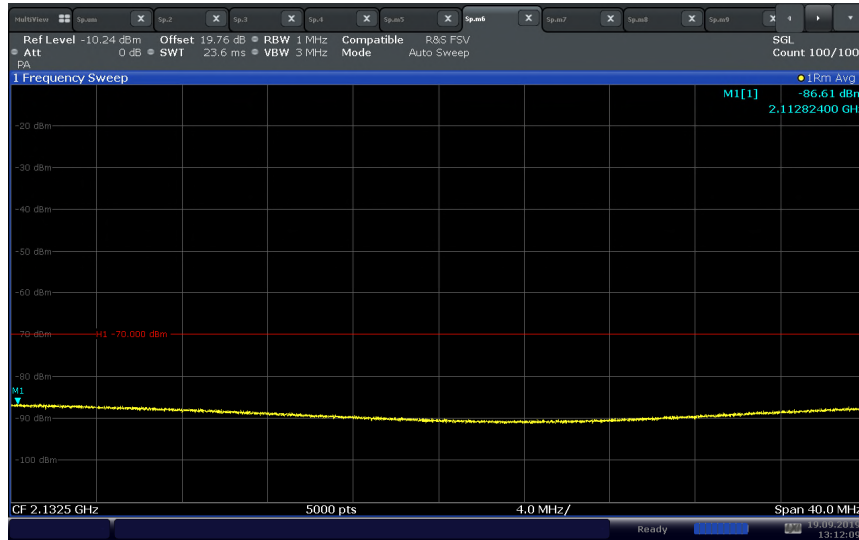

13:12:09 19.09.2019

### LTE Band 4 Uplink Authorized Frequency Range (1710 – 1755 MHz) – NU Port C (MCC/MNC: 311-480)

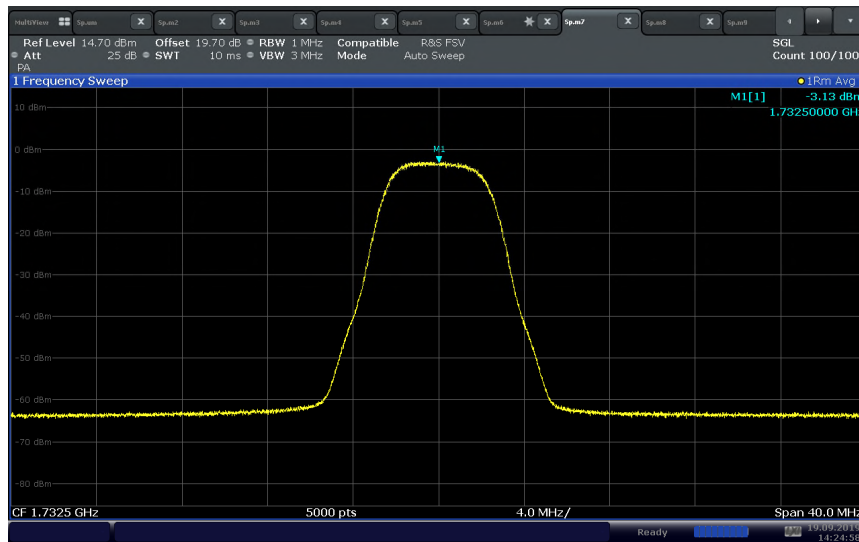

14:24:58 19.09.2019



FCC ID: NU: YETQ44-1M34CNU and CU: YETQ41-RECU  
IC: NU: 9892A-Q441M34CNU and CU: 9892A-Q41RECU

### LTE Band 4 Uplink Authorized Frequency Range (1710 – 1755 MHz) – NU Port C (MCC/MNC: 311-123)

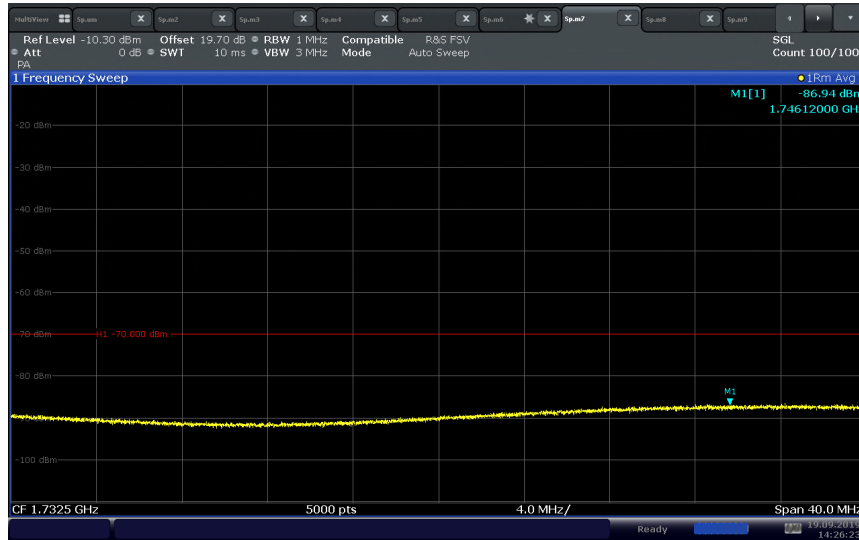

### LTE Band 4 Uplink Authorized Frequency Range (1710 – 1755 MHz) – NU Port C (MCC/MNC: 311-321)

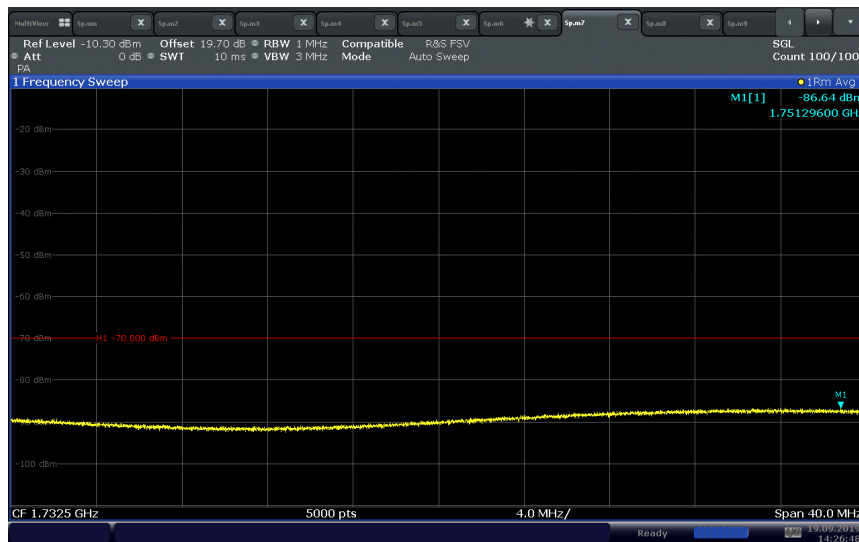



FCC ID: NU: YETQ44-1M34CNU and CU: YETQ41-RECU  
IC: NU: 9892A-Q441M34CNU and CU: 9892A-Q41RECU

**LTE Band 5 Downlink Authorized Frequency Range (869 - 894MHz) – CU with NU Port D (MCC/MNC: 311-490)**

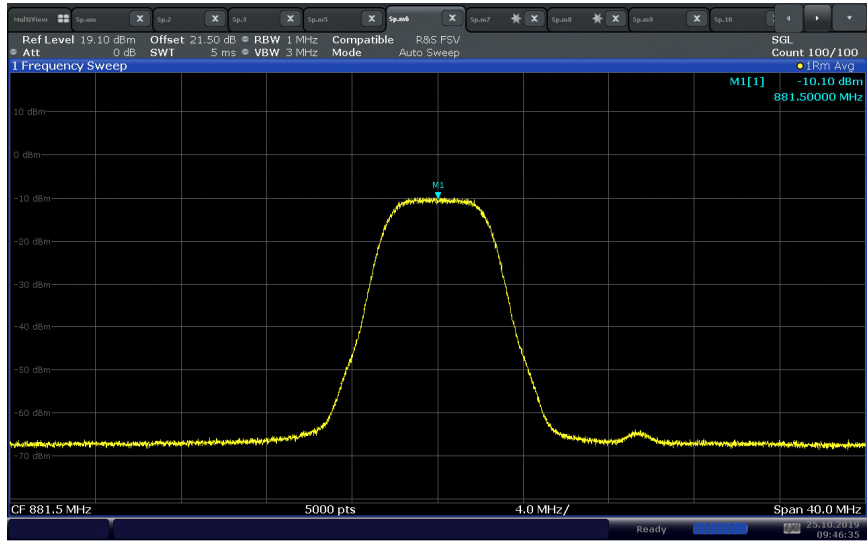

09:46:35 25.10.2019

**LTE Band 5 Downlink Authorized Frequency Range (869 - 894MHz) – CU with NU Port D (MCC/MNC: 311-123)**

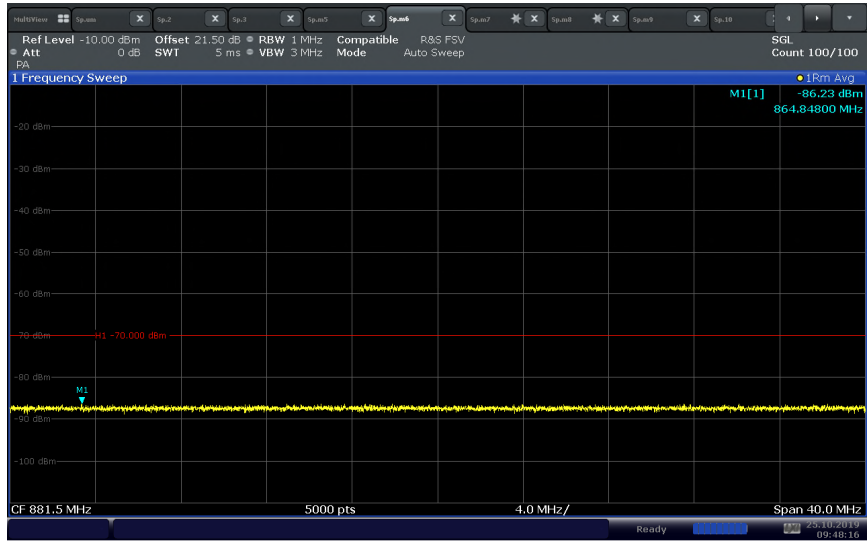

09:48:17 25.10.2019



FCC ID: NU: YETQ44-1M34CNU and CU: YETQ41-RECU  
IC: NU: 9892A-Q441M34CNU and CU: 9892A-Q41RECU

**LTE Band 5 Downlink Authorized Frequency Range (869 - 894MHz) – CU with NU Port D (MCC/MNC: 311-321)**

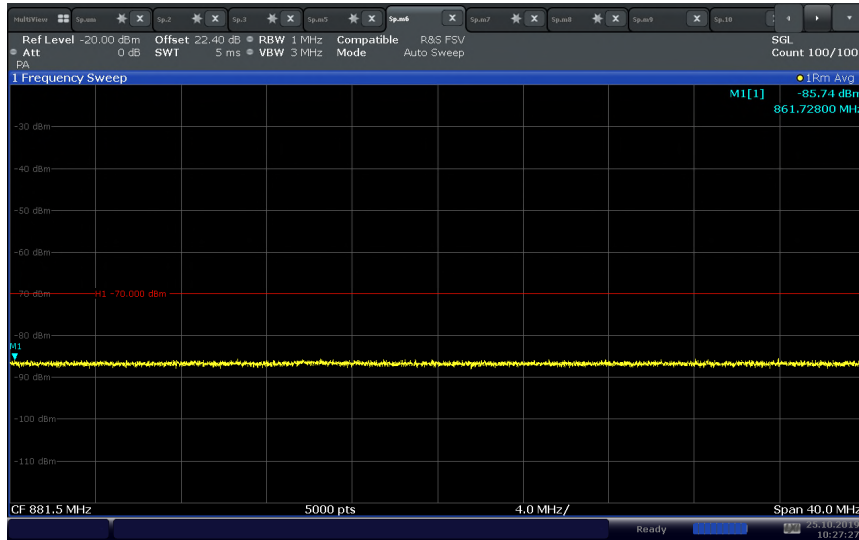

**LTE Band 5 Uplink Authorized Frequency Range (824 – 849 MHz) – NU Port D (MCC/MNC: 311-490)**

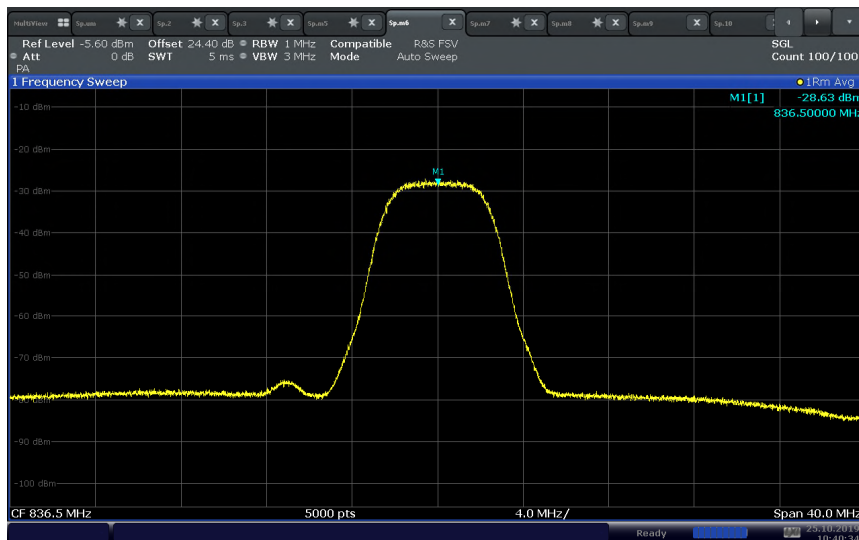



FCC ID: NU: YETQ44-1M34CNU and CU: YETQ41-RECU  
IC: NU: 9892A-Q441M34CNU and CU: 9892A-Q41RECU

### LTE Band 5 Uplink Authorized Frequency Range (824 – 849 MHz) – NU Port D (MCC/MNC: 311-123)

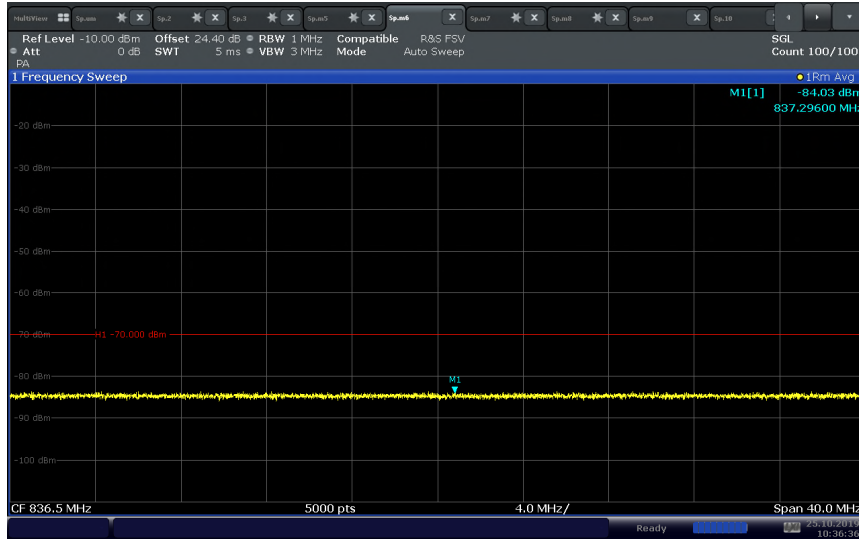

10:36:37 25.10.2019

### LTE Band 5 Uplink Authorized Frequency Range (824 – 849 MHz) – NU Port D (MCC/MNC: 311-321)

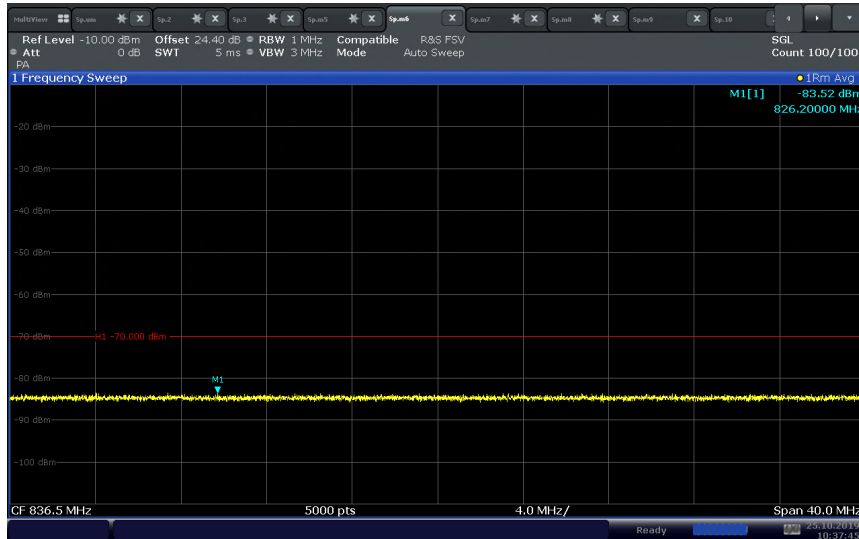

10:37:46 25.10.2019



FCC ID: NU: YETQ44-1M34CNU and CU: YETQ41-RECU  
IC: NU: 9892A-Q441M34CNU and CU: 9892A-Q41RECU

**LTE Band 12 Downlink Authorized Frequency Range (729 – 746 MHz) – CU with NU Port A (MCC/MNC: 310-410)**

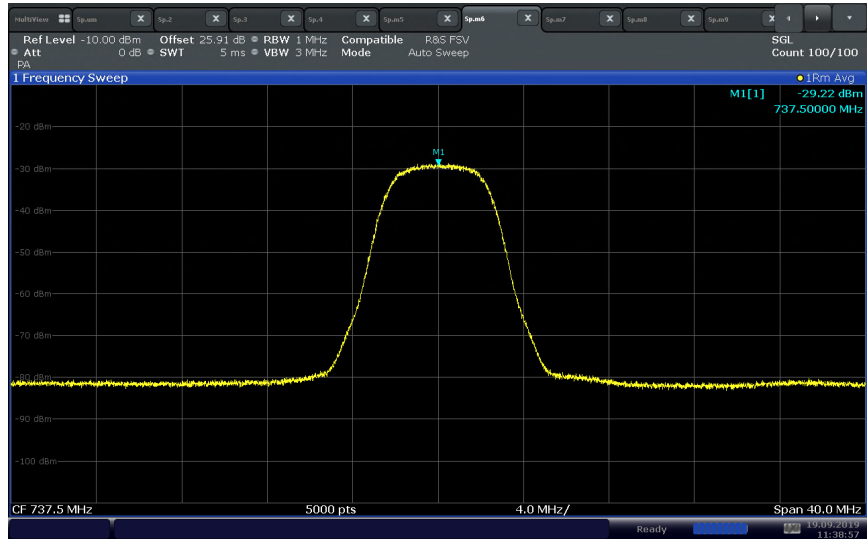

**LTE Band 12 Downlink Authorized Frequency Range (729 – 746 MHz) – CU with NU Port A (MCC/MNC: 310-123)**

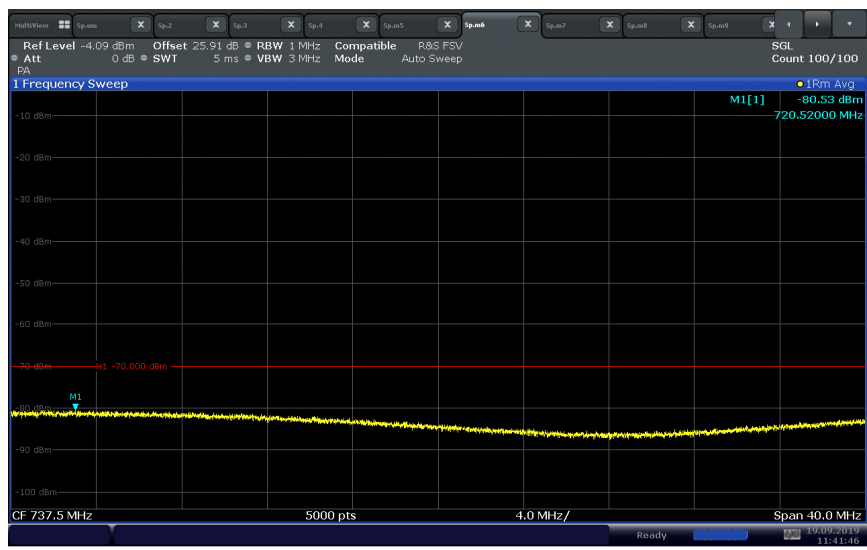





FCC ID: NU: YETQ44-1M34CNU and CU: YETQ41-RECU  
IC: NU: 9892A-Q441M34CNU and CU: 9892A-Q41RECU

**LTE Band 12 Downlink Authorized Frequency Range (729 – 746 MHz) – CU with NU Port A (MCC/MNC: 310-321)**

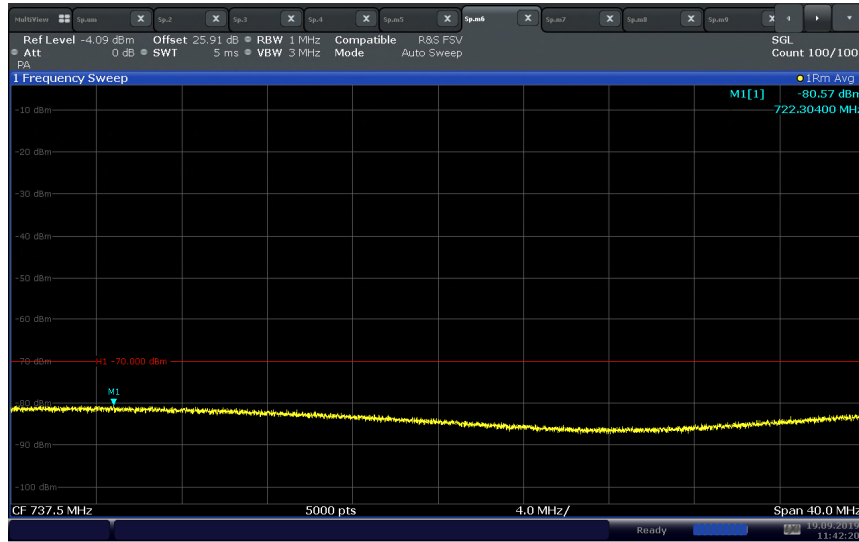

11:42:21 19.09.2019

**LTE Band 12 Uplink Authorized Frequency Range (699 – 716 MHz) – NU Port A (MCC/MNC: 310-410)**

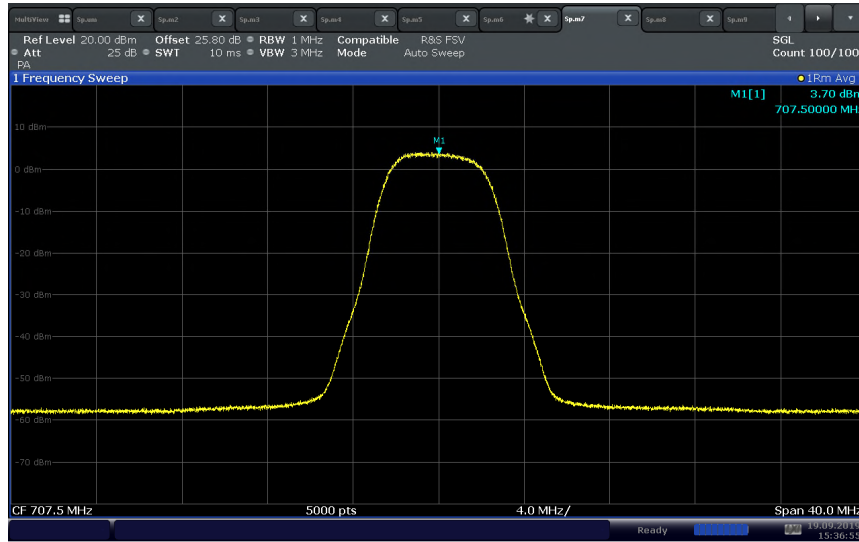

15:36:55 19.09.2019



FCC ID: NU: YETQ44-1M34CNU and CU: YETQ41-RECU  
IC: NU: 9892A-Q441M34CNU and CU: 9892A-Q41RECU

### LTE Band 12 Uplink Authorized Frequency Range (699 – 716 MHz) – NU Port A (MCC/MNC: 310-123)

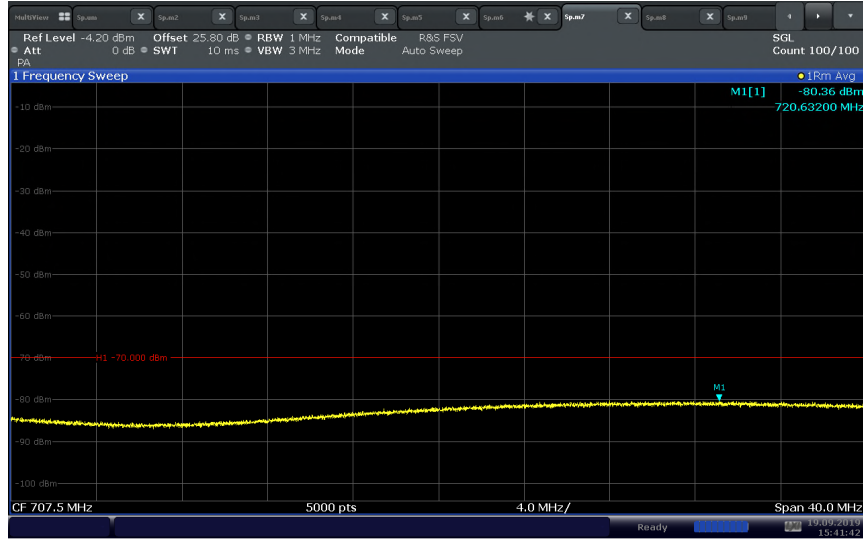

### LTE Band 12 Uplink Authorized Frequency Range (699 – 716 MHz) – NU Port A (MCC/MNC: 310-321)

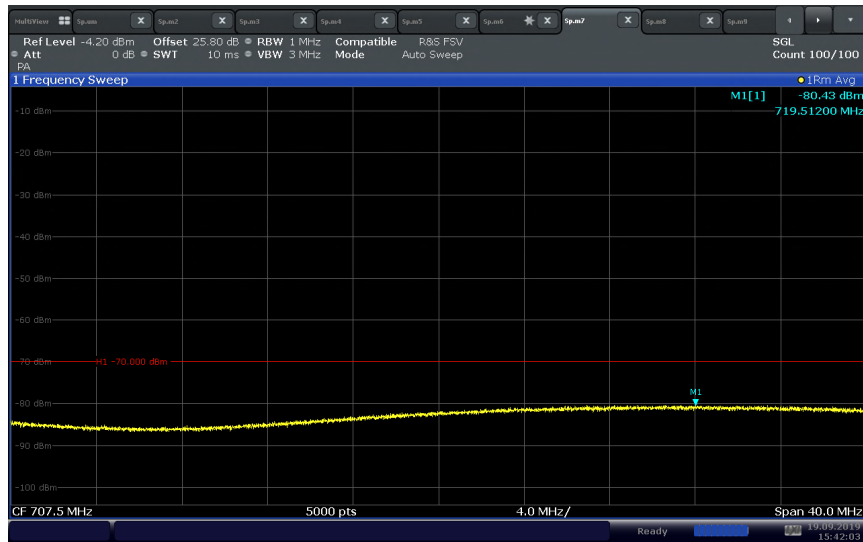



FCC ID: NU: YETQ44-1M34CNU and CU: YETQ41-RECU  
IC: NU: 9892A-Q441M34CNU and CU: 9892A-Q41RECU

**LTE Band 12 Downlink Authorized Frequency Range (729 – 746 MHz) – CU with NU Port B (MCC/MNC: 310-260)**

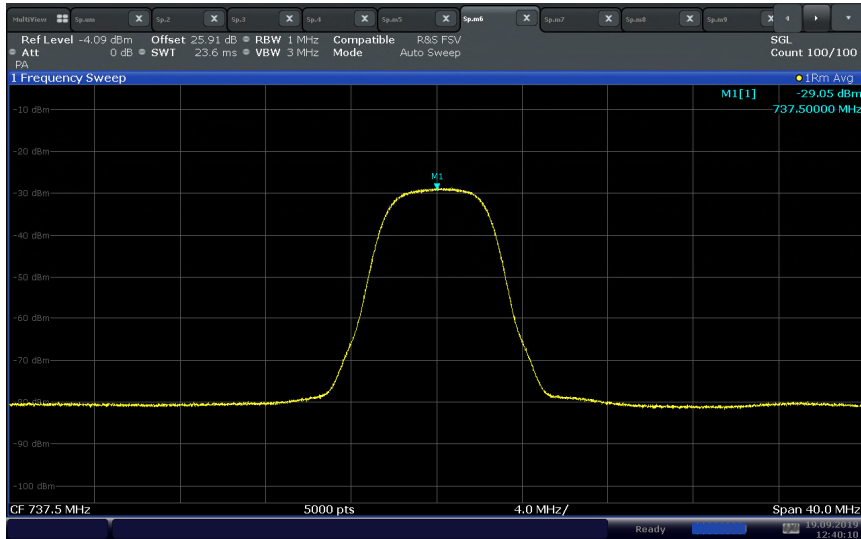

**LTE Band 12 Downlink Authorized Frequency Range (729 – 746 MHz) – CU with NU Port B (MCC/MNC: 310-123)**

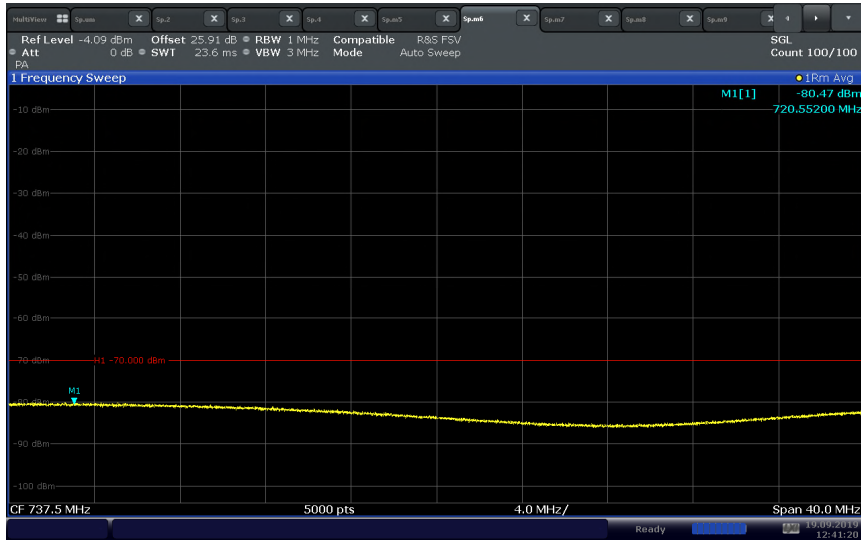



FCC ID: NU: YETQ44-1M34CNU and CU: YETQ41-RECU  
IC: NU: 9892A-Q441M34CNU and CU: 9892A-Q41RECU

**LTE Band 12 Downlink Authorized Frequency Range (729 – 746 MHz) – CU with NU Port B (MCC/MNC: 310-321)**

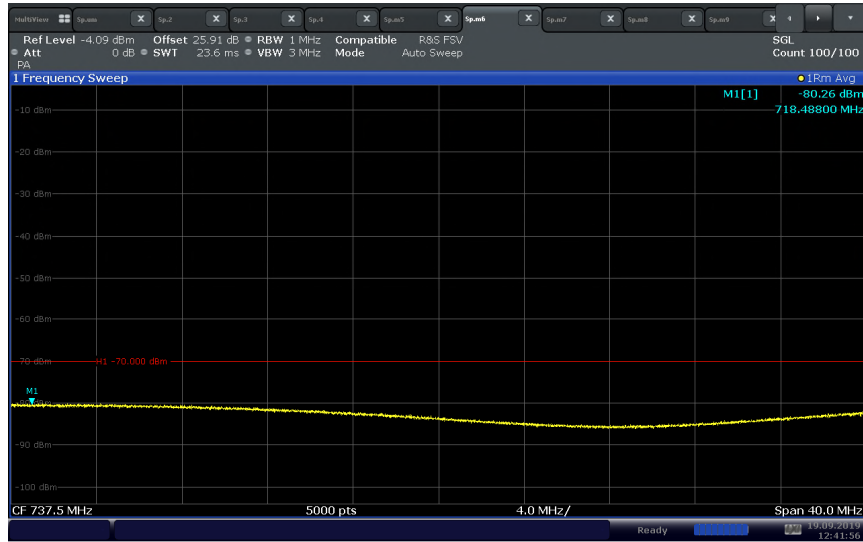

**LTE Band 12 Uplink Authorized Frequency Range (699 – 716 MHz) – NU Port B (MCC/MNC: 310-260)**

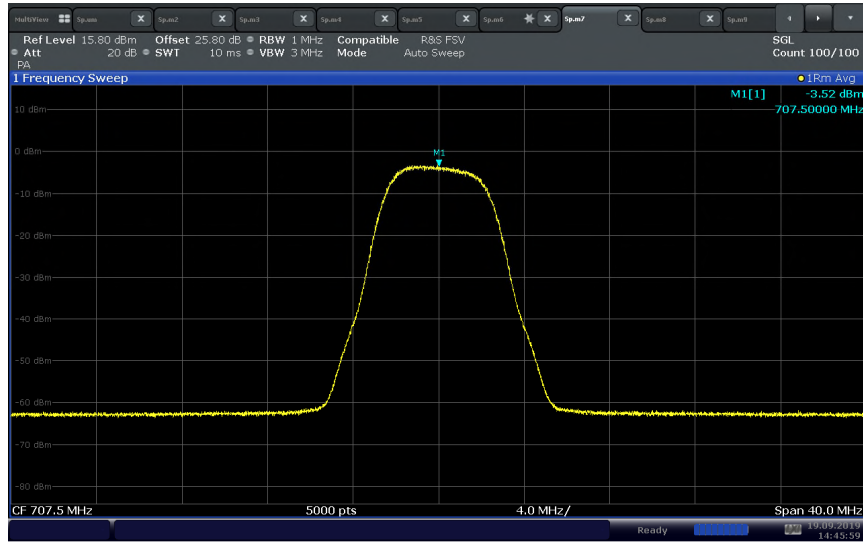



FCC ID: NU: YETQ44-1M34CNU and CU: YETQ41-RECU  
IC: NU: 9892A-Q441M34CNU and CU: 9892A-Q41RECU

### LTE Band 12 Uplink Authorized Frequency Range (699 – 716 MHz) – NU Port B (MCC/MNC: 310-123)

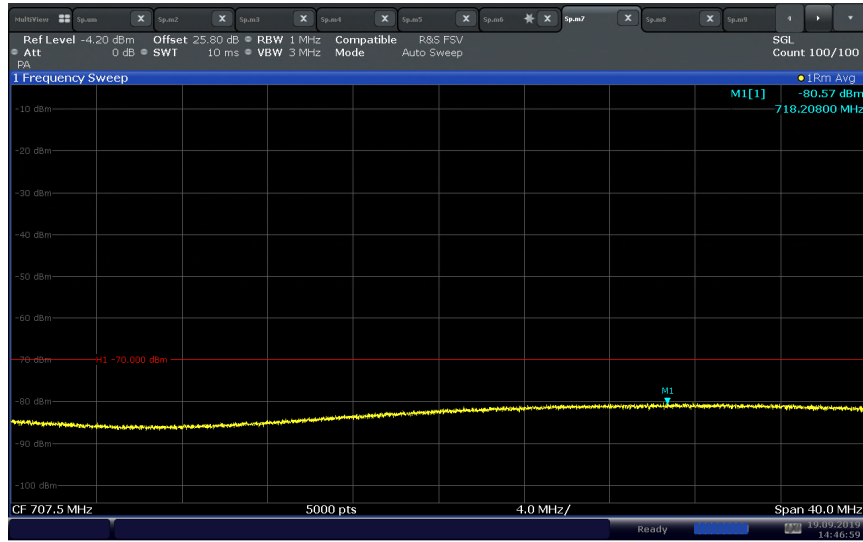

### LTE Band 12 Uplink Authorized Frequency Range (699 – 716 MHz) – NU Port B (MCC/MNC: 310-321)

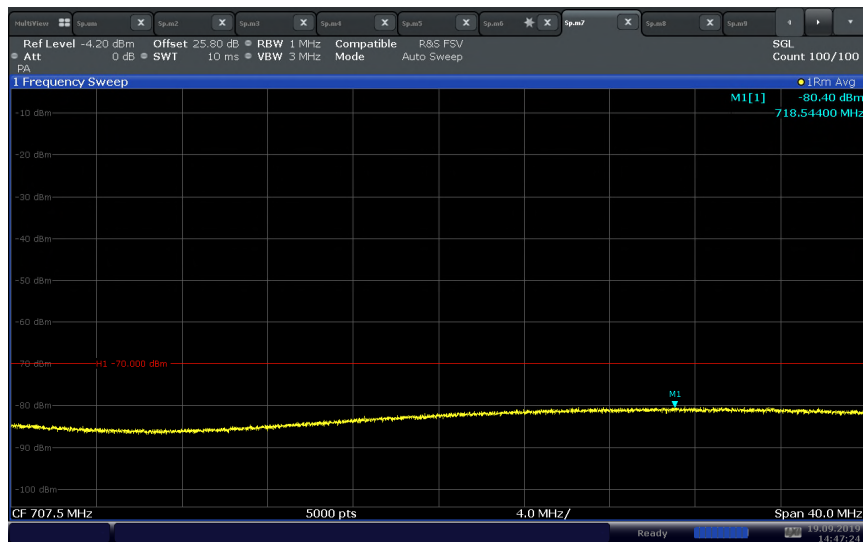



FCC ID: NU: YETQ44-1M34CNU and CU: YETQ41-RECU  
IC: NU: 9892A-Q441M34CNU and CU: 9892A-Q41RECU

**LTE Band 13 Downlink Authorized Frequency Range (746 – 756 MHz) – CU with NU Port C (MCC/MNC: 311-480)**

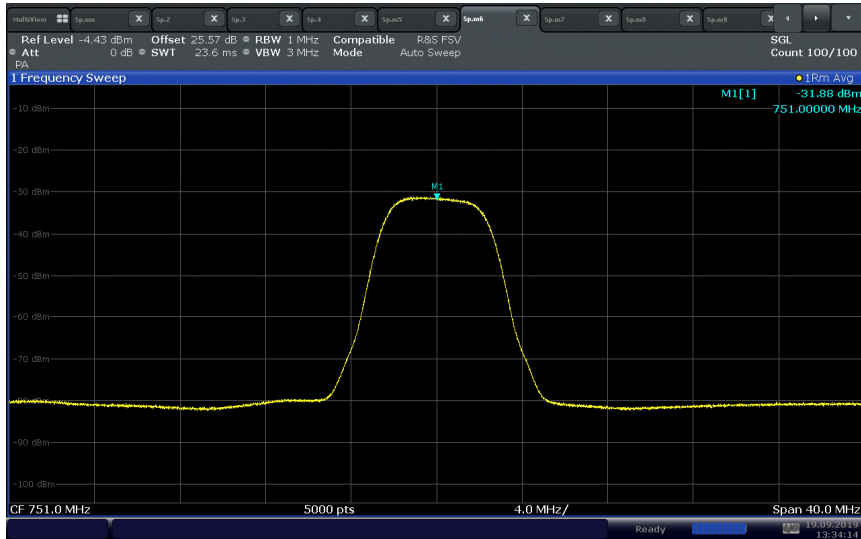

**LTE Band 13 Downlink Authorized Frequency Range (746 – 756 MHz) – CU with NU Port C (MCC/MNC: 310-123)**

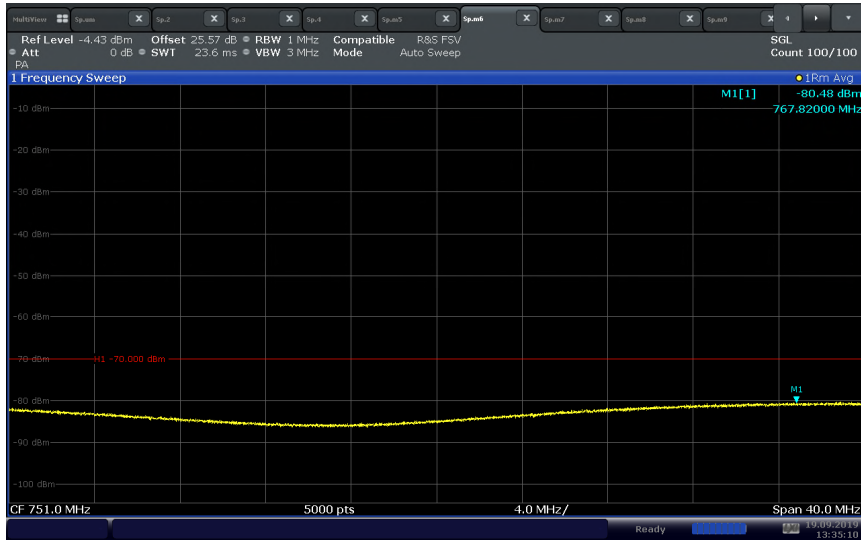



FCC ID: NU: YETQ44-1M34CNU and CU: YETQ41-RECU  
IC: NU: 9892A-Q441M34CNU and CU: 9892A-Q41RECU

**LTE Band 13 Downlink Authorized Frequency Range (746 – 756 MHz) – CU with NU Port C (MCC/MNC: 310-321)**

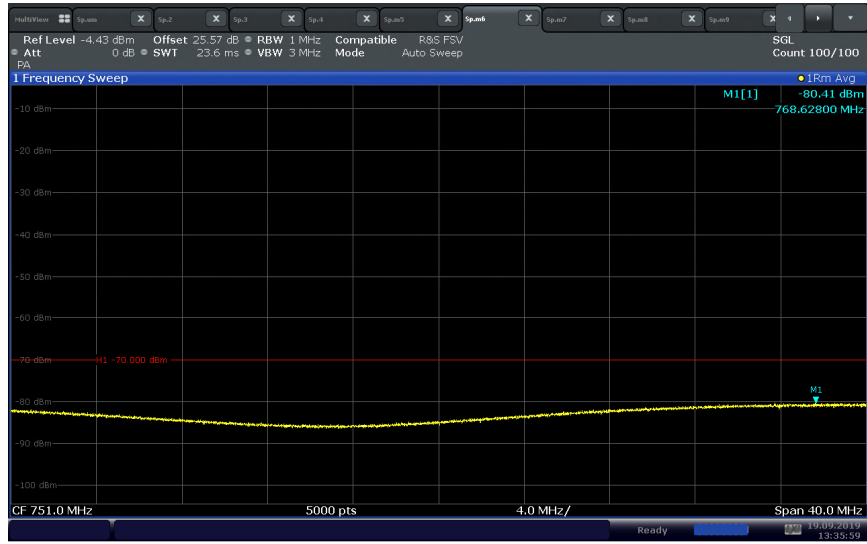

**LTE Band 13 Uplink Authorized Frequency Range (777 – 787 MHz) – NU Port C (MCC/MNC: 311-480)**

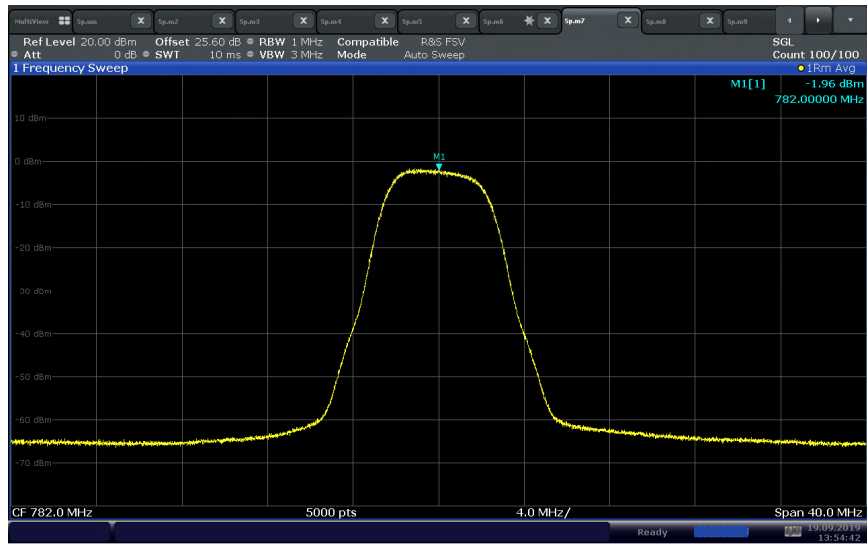



FCC ID: NU: YETQ44-1M34CNU and CU: YETQ41-RECU  
IC: NU: 9892A-Q441M34CNU and CU: 9892A-Q41RECU

**LTE Band 13 Uplink Authorized Frequency Range (777 – 787 MHz) – NU Port C  
(MCC/MNC: 311-123)**

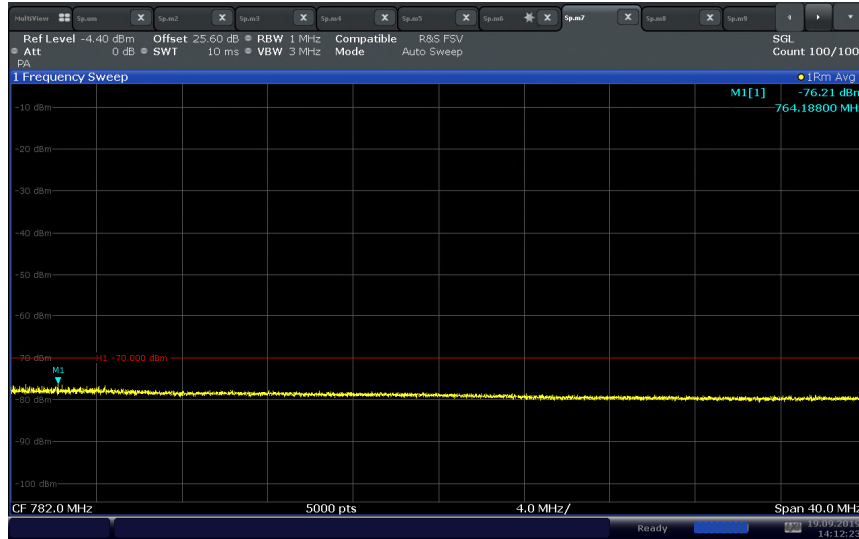

14:12:23 19.09.2019

**LTE Band 13 Uplink Authorized Frequency Range (777 – 787 MHz) – NU Port C  
(MCC/MNC: 311-321)**

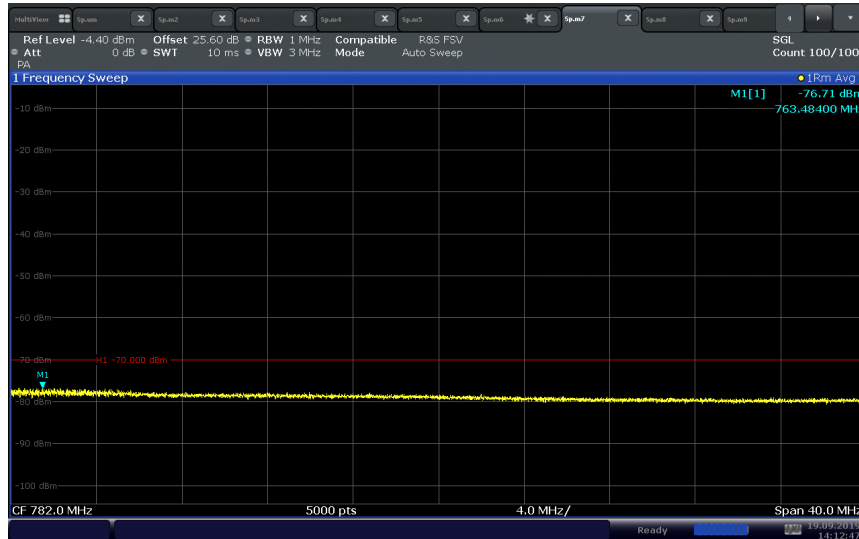

14:12:48 19.09.2019





FCC ID: NU: YETQ44-1M34CNU and CU: YETQ41-RECU  
IC: NU: 9892A-Q441M34CNU and CU: 9892A-Q41RECU

### LTE Band 25 Downlink Authorized Frequency Range (1930 – 1995 MHz) – CU with NU Port A (MCC/MNC: 310-410)

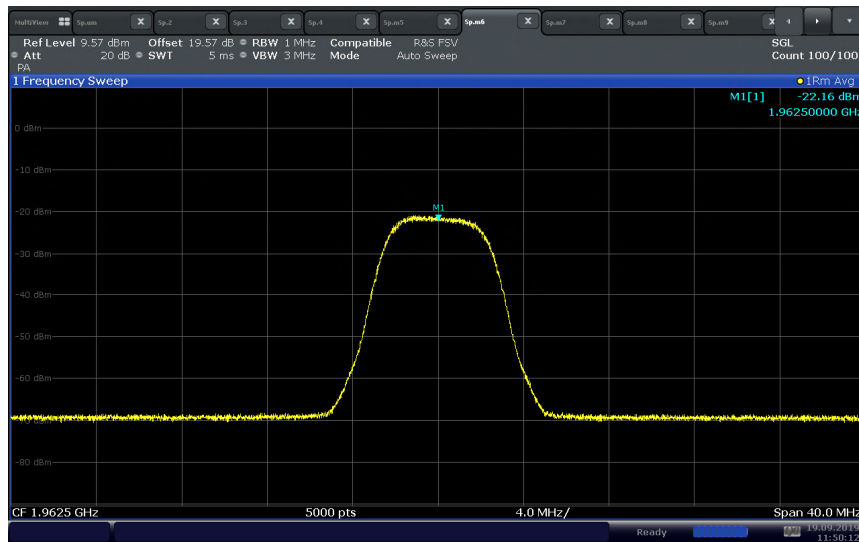

11:50:12 19.09.2019

### LTE Band 25 Downlink Authorized Frequency Range (1930 – 1995 MHz) – CU with NU Port A (MCC/MNC: 310-123)

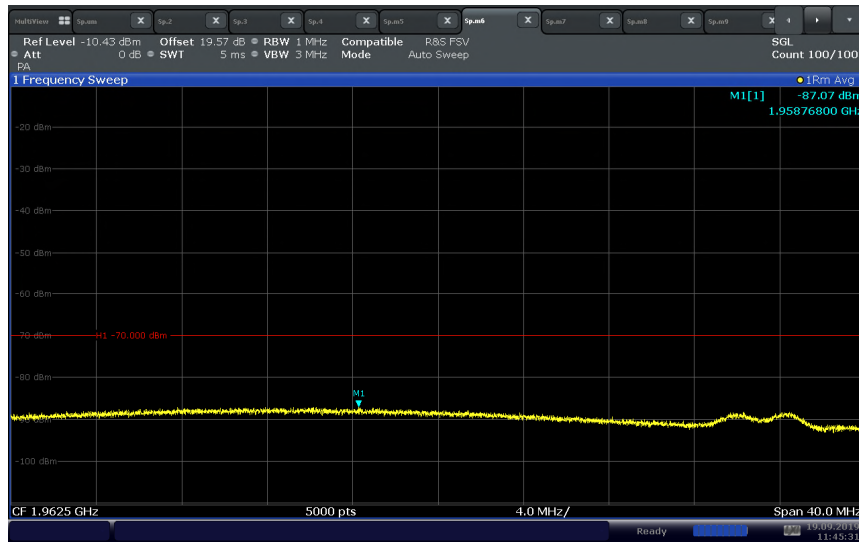

11:45:31 19.09.2019



FCC ID: NU: YETQ44-1M34CNU and CU: YETQ41-RECU  
IC: NU: 9892A-Q441M34CNU and CU: 9892A-Q41RECU

**LTE Band 25 Downlink Authorized Frequency Range (1930 – 1995 MHz) – CU with NU Port A  
(MCC/MNC: 310-321)**

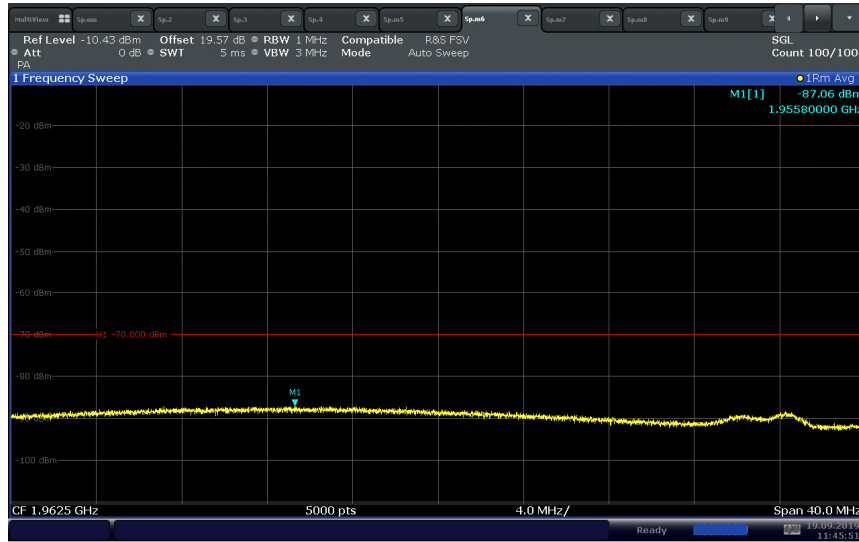

11:45:52 19.09.2019

**LTE Band 25 Uplink Authorized Frequency Range (1850 – 1915 MHz) – NU Port A  
(MCC/MNC: 310-410)**

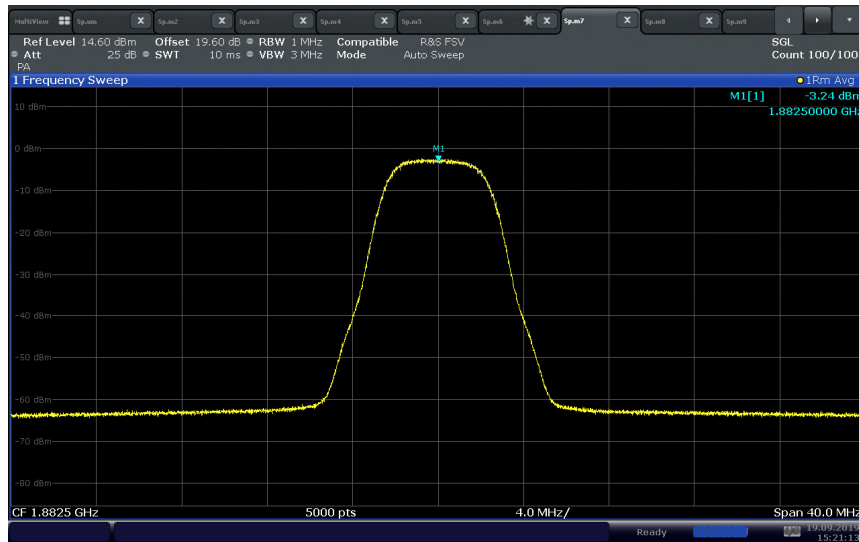

15:21:14 19.09.2019



FCC ID: NU: YETQ44-1M34CNU and CU: YETQ41-RECU  
IC: NU: 9892A-Q441M34CNU and CU: 9892A-Q41RECU

### LTE Band 25 Uplink Authorized Frequency Range (1850 – 1915 MHz) – NU Port A (MCC/MNC: 310-123)

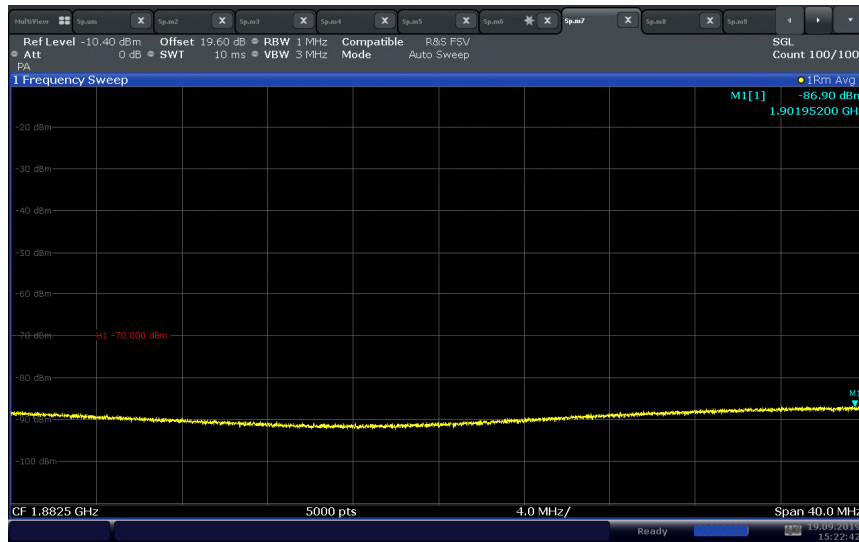

15:22:42 19.09.2019

### LTE Band 25 Uplink Authorized Frequency Range (1850 – 1915 MHz) – NU Port A (MCC/MNC: 310-321)

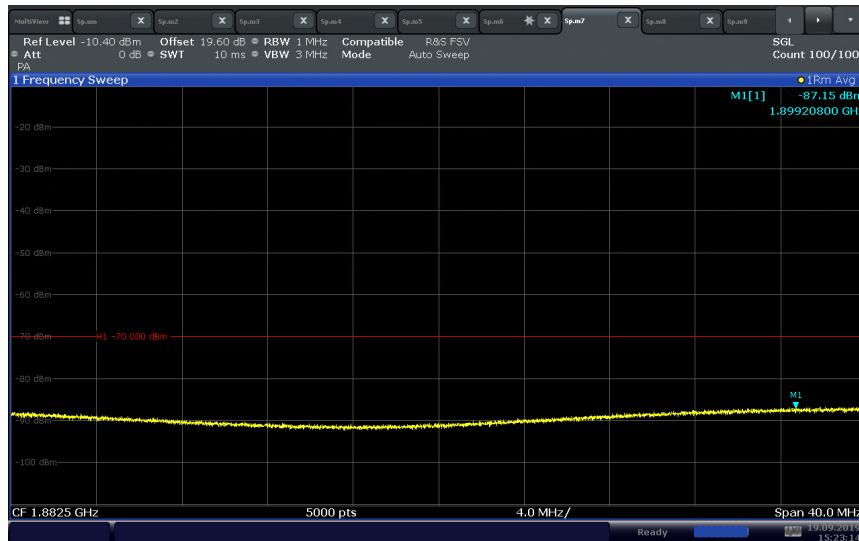

15:23:15 19.09.2019



FCC ID: NU: YETQ44-1M34CNU and CU: YETQ41-RECU  
IC: NU: 9892A-Q441M34CNU and CU: 9892A-Q41RECU

### LTE Band 25 Downlink Authorized Frequency Range (1930 – 1995 MHz) – CU with NU Port B (MCC/MNC: 310-260)

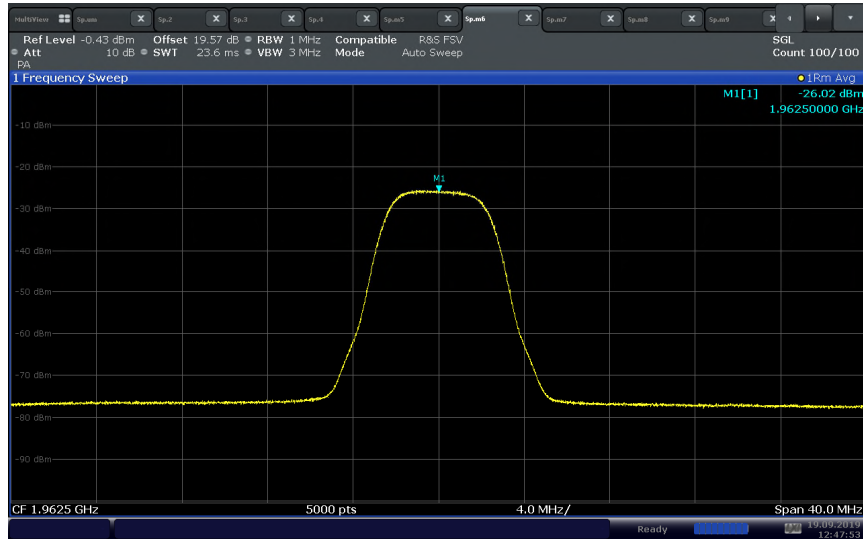

### LTE Band 25 Downlink Authorized Frequency Range (1930 – 1995 MHz) – CU with NU Port B (MCC/MNC: 310-123)

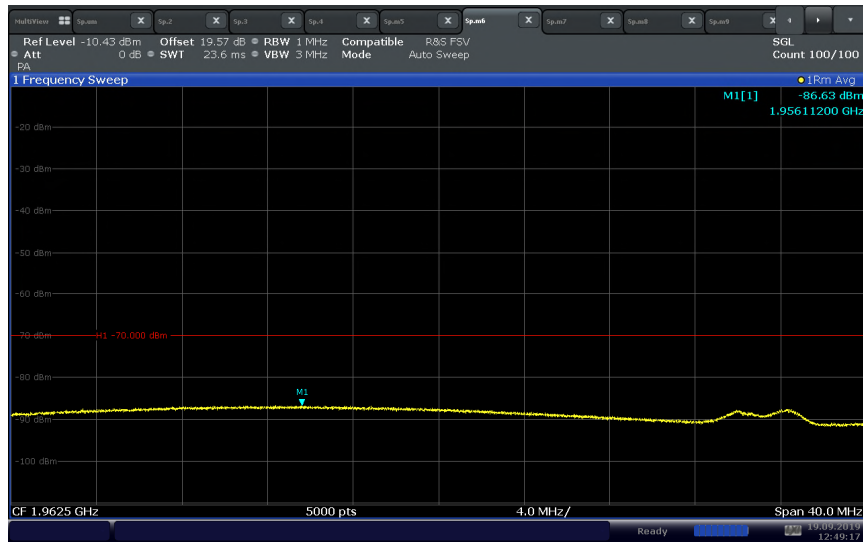



FCC ID: NU: YETQ44-1M34CNU and CU: YETQ41-RECU  
IC: NU: 9892A-Q441M34CNU and CU: 9892A-Q41RECU

### LTE Band 25 Downlink Authorized Frequency Range (1930 – 1995 MHz) – CU with NU Port B (MCC/MNC: 310-321)

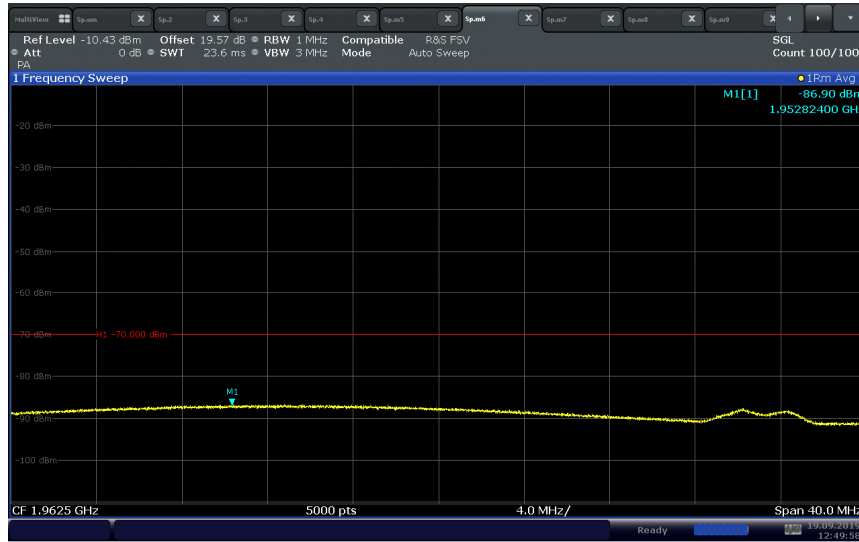

### LTE Band 25 Uplink Authorized Frequency Range (1850 – 1915 MHz) – NU Port B (MCC/MNC: 310-260)

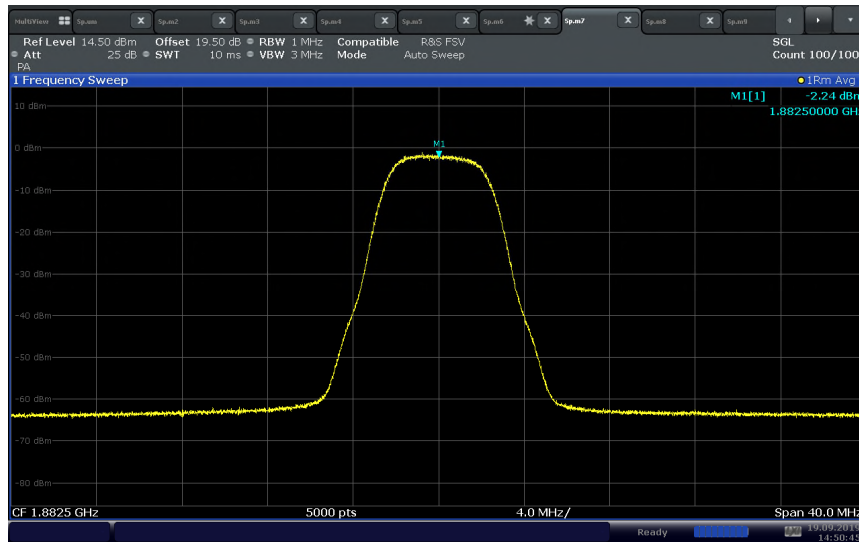



FCC ID: NU: YETQ44-1M34CNU and CU: YETQ41-RECU  
IC: NU: 9892A-Q441M34CNU and CU: 9892A-Q41RECU

### LTE Band 25 Uplink Authorized Frequency Range (1850 – 1915 MHz) – NU Port B (MCC/MNC: 310-123)

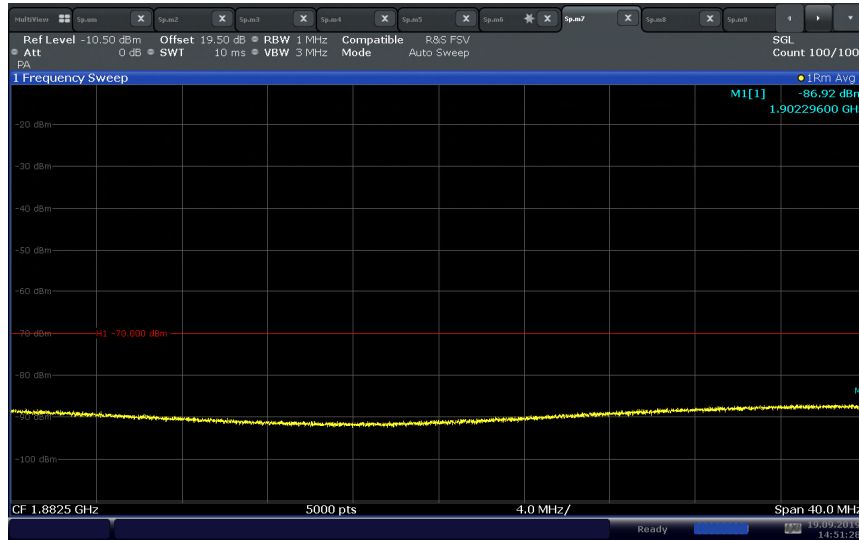

14:51:28 19.09.2019

### LTE Band 25 Uplink Authorized Frequency Range (1850 – 1915 MHz) – NU Port B (MCC/MNC: 310-321)

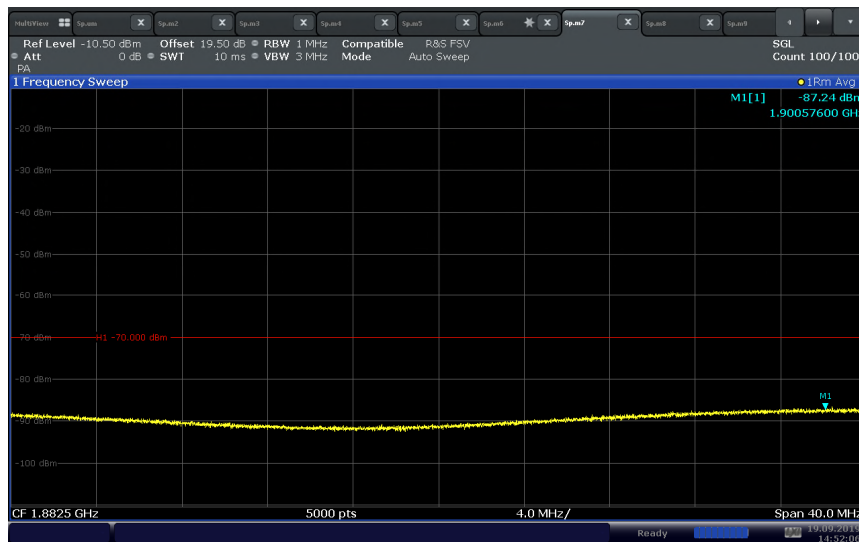

14:52:06 19.09.2019



FCC ID: NU: YETQ44-1M34CNU and CU: YETQ41-RECU  
IC: NU: 9892A-Q441M34CNU and CU: 9892A-Q41RECU

### LTE Band 25 Downlink Authorized Frequency Range (1930 – 1995 MHz) – CU with NU Port C (MCC/MNC: 311-480)

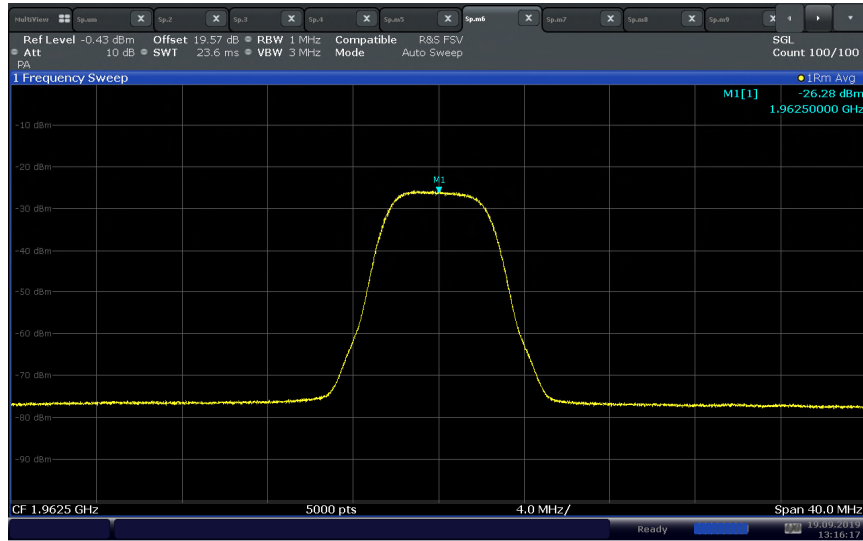

13:16:18 19.09.2019

### LTE Band 25 Downlink Authorized Frequency Range (1930 – 1995 MHz) – CU with NU Port C (MCC/MNC: 311-123)

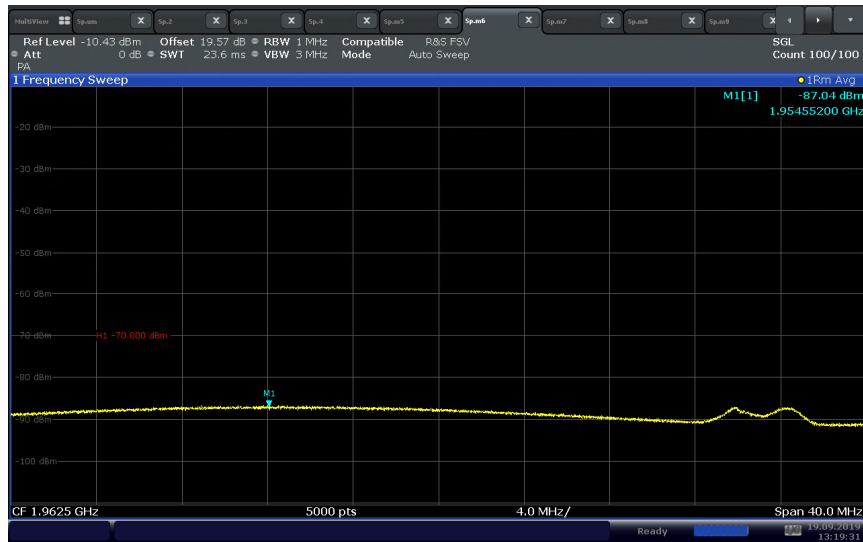

13:19:32 19.09.2019



FCC ID: NU: YETQ44-1M34CNU and CU: YETQ41-RECU  
IC: NU: 9892A-Q441M34CNU and CU: 9892A-Q41RECU

### LTE Band 25 Downlink Authorized Frequency Range (1930 – 1995 MHz) – CU with NU Port C (MCC/MNC: 311-321)

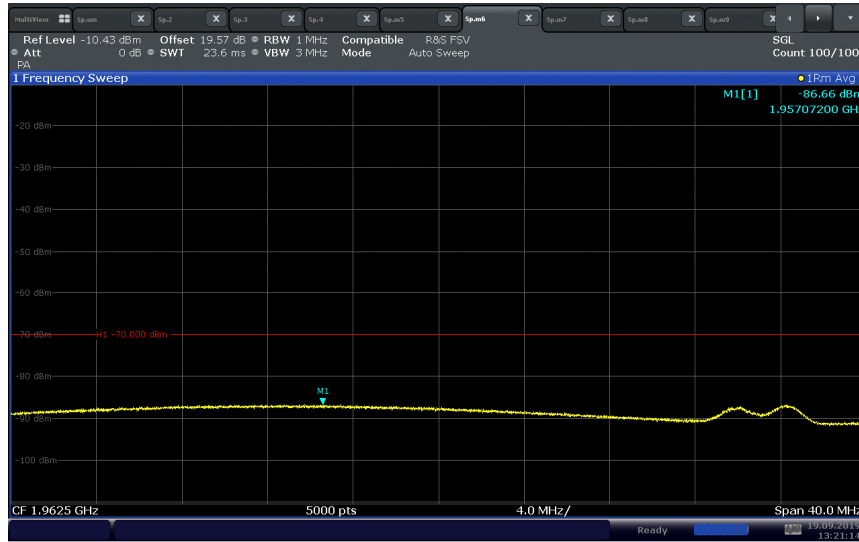

### LTE Band 25 Uplink Authorized Frequency Range (1850 – 1915 MHz) – NU Port C (MCC/MNC: 311-480)

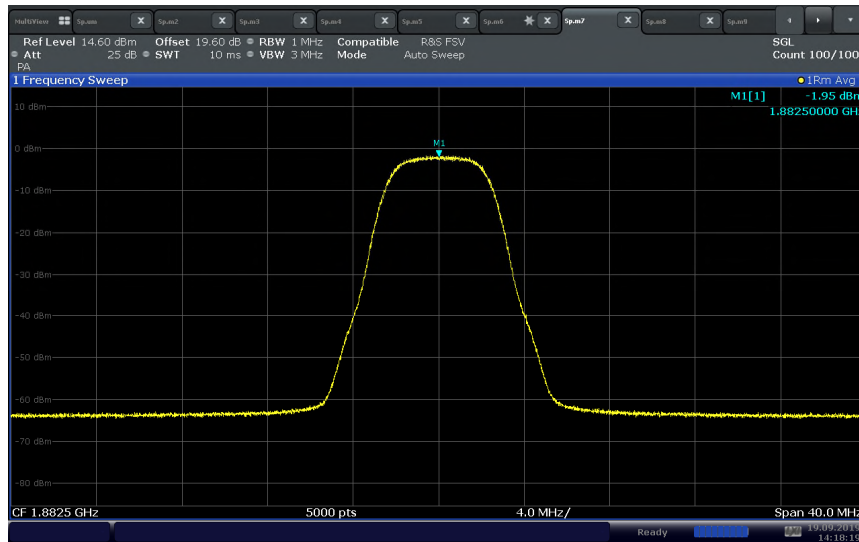





FCC ID: NU: YETQ44-1M34CNU and CU: YETQ41-RECU  
IC: NU: 9892A-Q441M34CNU and CU: 9892A-Q41RECU

### LTE Band 25 Uplink Authorized Frequency Range (1850 – 1915 MHz) – NU Port C (MCC/MNC: 311-123)

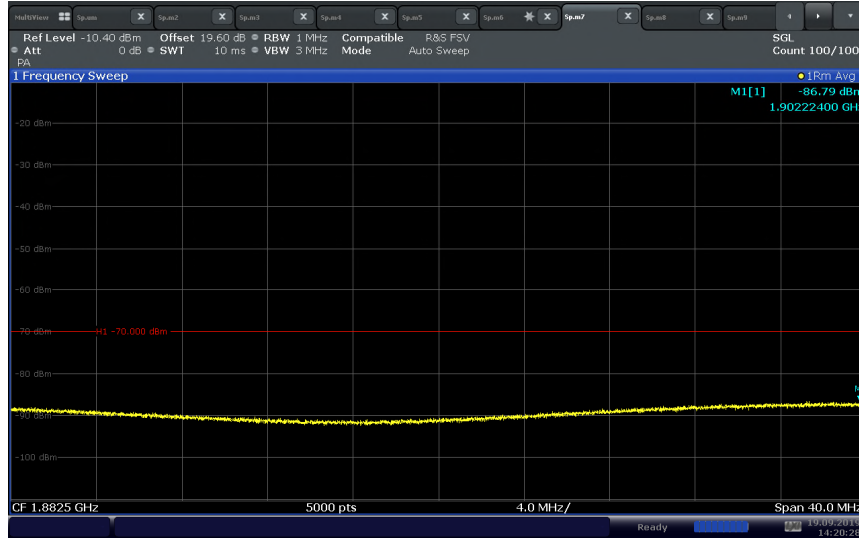

### LTE Band 25 Uplink Authorized Frequency Range (1850 – 1915 MHz) – NU Port C (MCC/MNC: 311-321)

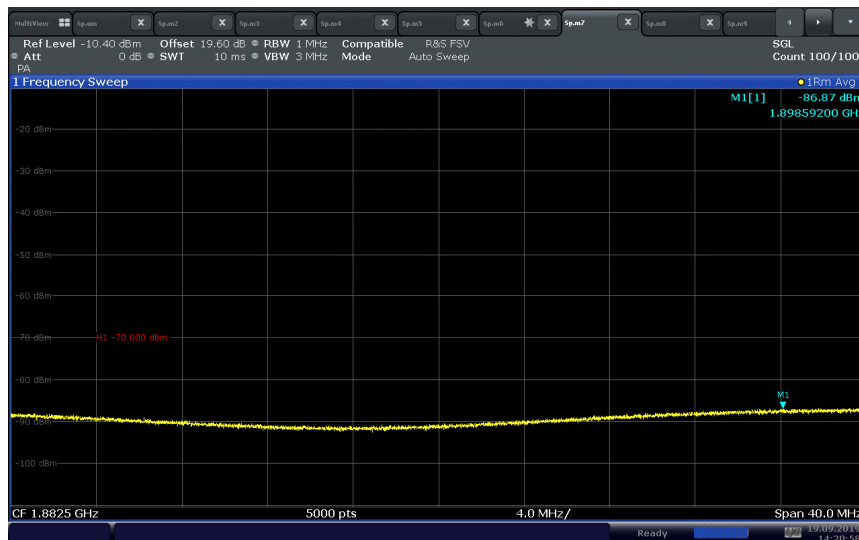



FCC ID: NU: YETQ44-1M34CNU and CU: YETQ41-RECU  
IC: NU: 9892A-Q441M34CNU and CU: 9892A-Q41RECU

**LTE Band 25 Downlink Authorized Frequency Range (1930 – 1995 MHz) – CU with NU Port D (MCC/MNC: 311-490)**

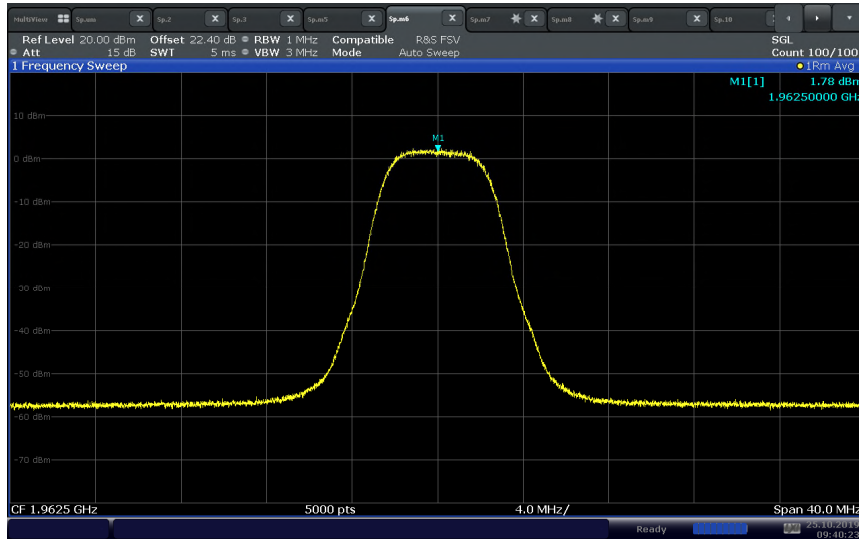

09:40:23 25.10.2019

**LTE Band 25 Downlink Authorized Frequency Range (1930 – 1995 MHz) – CU with NU Port D (MCC/MNC: 311-123)**

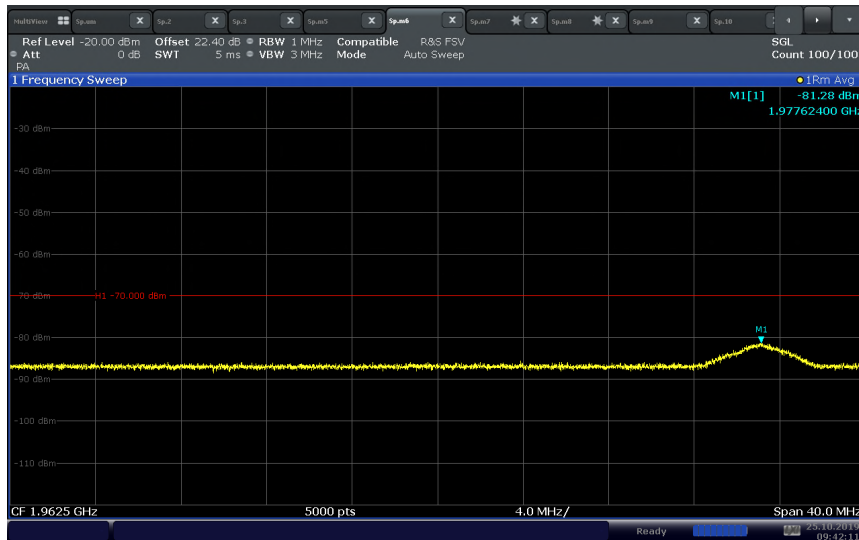

09:42:11 25.10.2019



FCC ID: NU: YETQ44-1M34CNU and CU: YETQ41-RECU  
IC: NU: 9892A-Q441M34CNU and CU: 9892A-Q41RECU

### LTE Band 25 Downlink Authorized Frequency Range (1930 – 1995 MHz) – CU with NU Port D (MCC/MNC: 311-321)

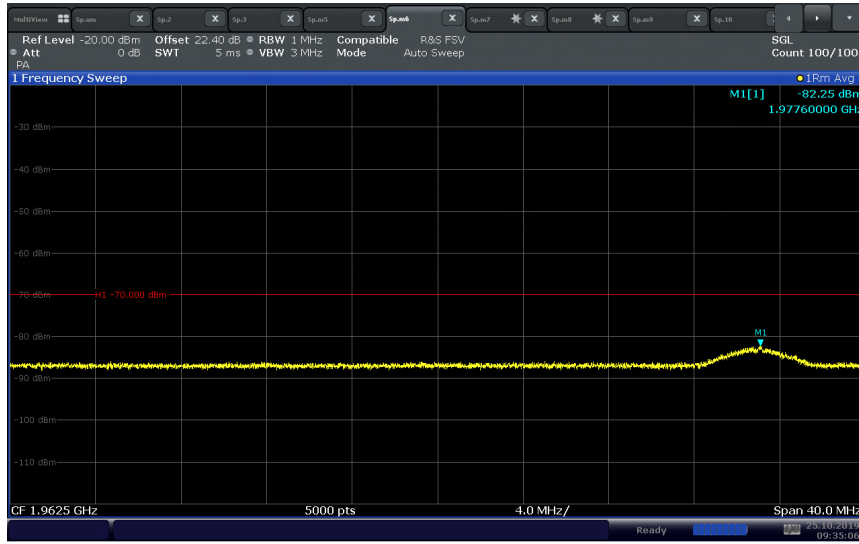

### LTE Band 25 Uplink Authorized Frequency Range (1850 – 1915 MHz) – NU Port D (MCC/MNC: 311-490)

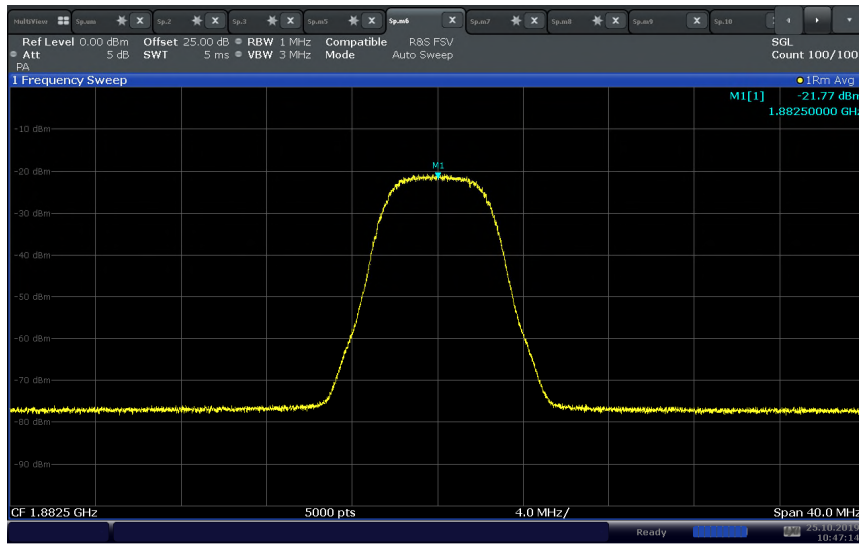



FCC ID: NU: YETQ44-1M34CNU and CU: YETQ41-RECU  
IC: NU: 9892A-Q441M34CNU and CU: 9892A-Q41RECU

### LTE Band 25 Uplink Authorized Frequency Range (1850 – 1915 MHz) – NU Port D (MCC/MNC: 311-123)

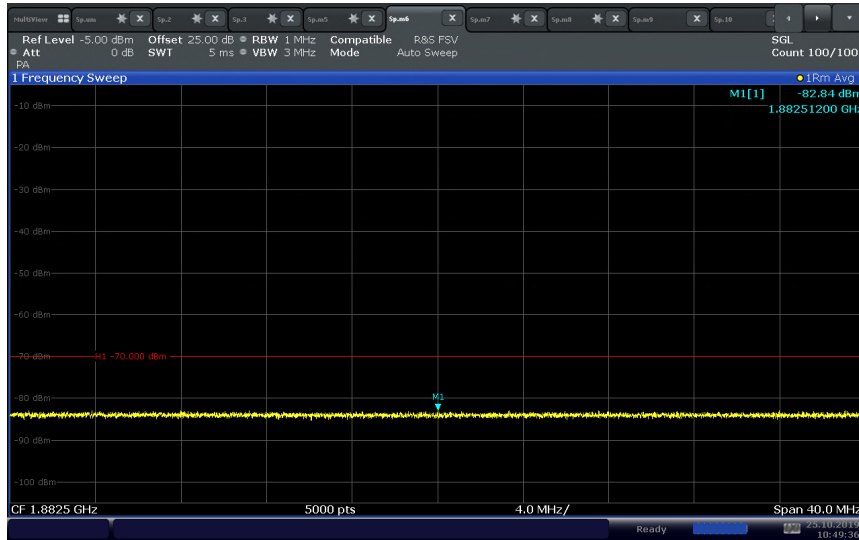

10:49:36 25.10.2019

### LTE Band 25 Uplink Authorized Frequency Range (1850 – 1915 MHz) – NU Port D (MCC/MNC: 311-321)

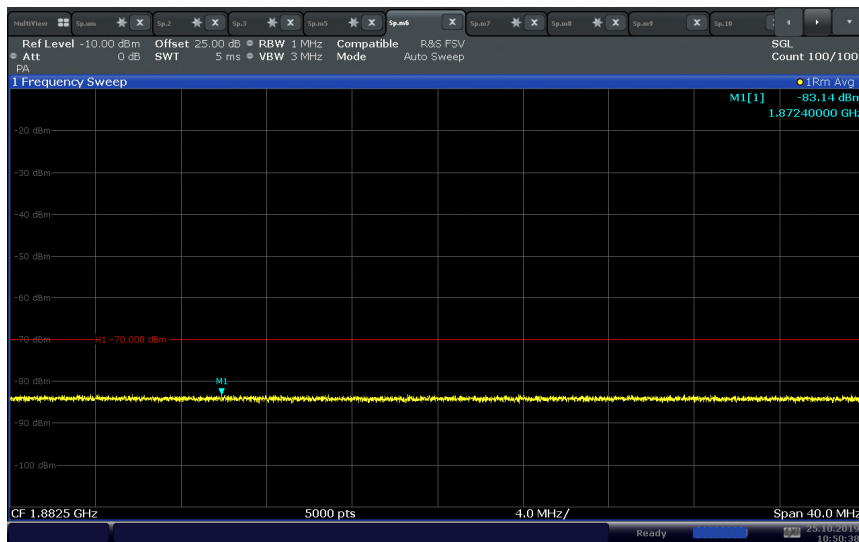

10:50:39 25.10.2019



FCC ID: NU: YETQ44-1M34CNU and CU: YETQ41-RECU  
IC: NU: 9892A-Q441M34CNU and CU: 9892A-Q41RECU

## **2.3 Maximum Power Measurement And Booster Gain Computation**

### **2.3.1 Specification Reference**

FCC 47 CFR Part 20, Clause 20.21(e)(9)(i)(D)  
FCC 47 CFR Part 20, Clause 20.21(e)(9)(i)(B)  
FCC 47 CFR Part 20, Clause 20.21(e)(9)(i)(C)(2)  
KDB935210 D04, Clause 7.2  
KDB935210 D04, Clause 7.33

### **2.3.2 Standard Applicable**

FCC 47 CFR Part 20, Clause 20.21(e)(9)(i)(D) Power Limits:  
A booster's uplink power must not exceed 1 watt composite conducted power and equivalent isotropic radiated power (EIRP) for each band of operation. Downlink power shall not exceed 0.05 watt (17dBm) composite and 10 dBm per channel conducted and EIRP for each band of operation. Compliance with power limits will use instrumentation calibrated in terms of RMS equivalent voltage.

FCC 47 CFR Part 20, Clause 20.21(e)(9)(i)(B) Bidirectional Capability:  
Consumer Boosters must be able to provide equivalent (within 9dB as per ANSI ASC C63) uplink and downlink gain and conducted uplink power output that is at least 0.05 watts. One-way consumer boosters (i.e., uplink only, downlink only, uplink impaired, downlink impaired) are prohibited. Spectrum block filtering used must provide uplink filter attenuation not less than the downlink filter attenuation, and where RSI is measured after spectrum block filtering is applied referenced to the booster's input port for each band of operation.

FCC 47 CFR Part 20, Clause 20.21(e)(9)(i)(C) Booster Gain Limits.  
The gain of the frequency selective consumer booster shall meet the limits below.  
(2) The uplink and downlink maximum gain of a frequency selective consumer booster referenced to its input and output ports shall not exceed 19.5 dB + 20 Log (Frequency), or 100 dB for systems having automatic gain adjustment based on isolation measurements between booster donor and server antennas.  
Where, Frequency is the uplink midband frequency of the supported spectrum bands in MHz..

### **2.3.3 Equipment Under Test and Modification State**

Serial No: 370920000139 (NU)and 371929000156 (CU) / Test Configuration (N/A, calculation only)

Cel-Fi Q4K-CBRS  
Serial No: 110222000051(NU) and 481222000175 (CU) / Test Configuration A and B

### **2.3.4 Date of Test/Initial of test personnel who performed the test**

August 02, 05, 08 and October 15, 2019 /XYZ  
December 28, 2022 and February 02, 2023/ MAR

### **2.3.5 Test Equipment Used**

The major items of test equipment used for the above tests are identified in Section 3.1.



FCC ID: NU: YETQ44-1M34CNU and CU: YETQ41-RECU  
 IC: NU: 9892A-Q441M34CNU and CU: 9892A-Q41RECU

**2.3.6 Environmental Conditions**

Test performed at TÜV SÜD America Inc. Mira Mesa facility.

		December 28, 2022	February 2, 2022
Ambient Temperature	24.5 - 26.3°C	24.4°C	23.2°C
Relative Humidity	45.0 - 53.3%	46.2%	35.6%
ATM Pressure	98.8 - 99.0kPa	100.2kPa	99.9kPa

**2.3.7 Additional Observations**

- Maximum gain data was leverage 72146075C Nextivity FCC Part 20 W B5 L B4 B12 B13 25 30 71 Test Report.pdf.
- Conducted output power, maximum system gain (Antenna and Cable) and EIRP tests/calculations were performed on Cel-Fi Q4K-CBRS
- For WCDMA B5 downlink, conducted output power per channel was performed on Cel-Fi Q4K-CBRS
- This is conducted Test. Test procedure is per Section 7.2.2 of KDB935210 (D04 Provider Specific Booster Measurements v02r03). Appropriate offset (line losses) applied.
- The EUT operated in Test Mode, with the gain set to the maximum gain and a minimum bandwidth setting (5MHz).
- Setup the EUT according to Figure 2 or 3 of Section 6.3.3 of KDB935210 as appropriate.
- Maximum Gain of the booster was calculated.
- The Gain with Maximum Transmitter Input Level (-20dBm for Downlink and 0dBm for Uplink) injected was also calculated.
- Operational uplink and downlink bands for WCDMA Band 5 and LTE Band 4, 12, 13, 25 were tested.
- Evaluations are conducted at CU and NU antenna ports. The signal generator was set to transmit a 5MHz WCDMA or LTE signal.

**2.3.8 Test Results Maximum Gain**

Maximum Gain					
Band	Frequency Range (MHz)	Gain (dB)	Gain Limit (dB)	UL vs DL Gain	UL vs DL Gain Limit (dB)
WCDMA Band 5 Downlink (Port A)	869 - 894	94.01	100	0.71	9.0
WCDMA Band 5 Uplink (Port A)	824 - 849	94.72	100		
LTE Band 4 Downlink (Port A)	2110 - 2155	98.03	100	2.39	9.0
LTE Band 4 Uplink (Port A)	1710 - 1755	95.64	100		
LTE Band 4 Downlink (Port B)	2110 - 2155	97.79	100	2.53	9.0
LTE Band 4 Uplink (Port B)	1710 - 1755	95.26	100		
LTE Band 4 Downlink (Port C)	2110 - 2155	97.57	100	1.97	9.0



FCC ID: NU: YETQ44-1M34CNU and CU: YETQ41-RECU  
 IC: NU: 9892A-Q441M34CNU and CU: 9892A-Q41RECU

LTE Band 4 Uplink (Port C)	1710 - 1755	95.60	100		
LTE Band 12 Downlink (Port A)	729 - 746	94.44	100	0.01	9.0
LTE Band 12 Uplink (Port A)	699 - 716	94.43	100		
LTE Band 12 Downlink (Port B)	729 - 746	94.39	100	0.32	9.0
LTE Band 12 Uplink (Port B)	699 - 716	94.07	100		
LTE Band 13 Downlink (Port C)	746 - 756	93.91	100	0.6	9.0
LTE Band 13 Uplink (Port C)	777 - 787	94.51	100		
LTE Band 25 Downlink (Port A)	1930 - 1995	98.32	100	1.86	9.0
LTE Band 25 Uplink (Port A)	1850 - 1915	96.46	100		
LTE Band 25 Downlink (Port B)	1930 - 1995	97.93	100	1.57	9.0
LTE Band 25 Uplink (Port B)	1850 - 1915	96.36	100		
LTE Band 25 Downlink (Port C)	1930 - 1995	97.71	100	1.44	9.0
LTE Band 25 Uplink (Port C)	1850 - 1915	96.27	100		
LTE Band 25 Downlink (Port D)	1930 - 1995	97.54	100	0.34	9.0
LTE Band 25 Uplink (Port D)	1850 - 1915	97.88	100		



FCC ID: NU: YETQ44-1M34CNU and CU: YETQ41-RECU  
 IC: NU: 9892A-Q441M34CNU and CU: 9892A-Q41RECU

Maximum Gain with Maximum Transmitter Input level			
Band	Frequency Range (MHz)	Gain (dB)	Gain Limit (dB)
WCDMA Band 5 Downlink (Port A)	869 - 894	31.14	100
WCDMA Band 5 Uplink (Port A)	824 - 849	21.23	100
LTE Band 4 Downlink (Port A)	2110 - 2155	31.04	100
LTE Band 4 Uplink (Port A)	1710 - 1755	22.67	100
LTE Band 4 Downlink (Port B)	2110 - 2155	31.0	100
LTE Band 4 Uplink (Port B)	1710 - 1755	22.05	100
LTE Band 4 Downlink (Port C)	2110 - 2155	30.98	100
LTE Band 4 Uplink (Port C)	1710 - 1755	22.10	100
LTE Band 12 Downlink (Port A)	729 - 746	31.13	100
LTE Band 12 Uplink (Port A)	699 - 716	23.52	100
LTE Band 12 Downlink (Port B)	729 - 746	31.10	100
LTE Band 12 Uplink (Port B)	699 - 716	22.97	100
LTE Band 13 Downlink (Port C)	746 - 756	31.15	100
LTE Band 13 Uplink (Port C)	777 - 787	23.46	100
LTE Band 25 Downlink (Port A)	1930 - 1995	31.61	100
LTE Band 25 Uplink(Port A)	1850 - 1915	21.61	100
LTE Band 25 Downlink (Port B)	1930 - 1995	31.15	100
LTE Band 25 Uplink(Port B)	1850 - 1915	21.58	100
LTE Band 25 Downlink (Port C)	1930 - 1995	30.96	100





Product Service

FCC ID: NU: YETQ44-1M34CNU and CU: YETQ41-RECU  
IC: NU: 9892A-Q441M34CNU and CU: 9892A-Q41RECU

LTE Band 25 Uplink (Port C)	1850 - 1915	21.04	100
LTE Band 25 Downlink (Port D)	1930 - 1995	31.02	100
LTE Band 25 Uplink (Port D)	1850 - 1915	21.36	100



FCC ID: NU: YETQ44-1M34CNU and CU: YETQ41-RECU  
 IC: NU: 9892A-Q441M34CNU and CU: 9892A-Q41RECU

**2.3.9 Test Results Power Output**

Power Output (Conducted / EIRP) WCDMA Band 5 Downlink								
Bandwidth	Channels	Frequency	Average Power	Peak Power	Maximum System Gain (Antenna + Cable) (dBi)	EIRP (dBm)		Average EIRP FCC Part 20 Limit (dBm)
(MHz)		(MHz)	(dBm)	(dBm)		Average	Peak	
5 MHz	4357	871.4	15.32	26.8	1.68	17	28.48	17
	4408	881.6	15.22	26.6	1.78	17	28.38	17
	4458	891.6	15.18	26.72	1.82	17	28.54	17
15 MHz	4357+4382+4407	871.4+876.4+881.4	<b>16.99</b>	28.37	<b>0.01</b>	17	28.38	17
	4383+4408+4433	876.6+881.6+886.6	16.8	27.96	0.2	17	28.16	17
	4408+4433+4458	881.6+886.6+891.6	16.93	28.45	0.07	17	28.52	17

Power Output (Conducted / EIRP) WCDMA Band 5 Uplink								
Bandwidth	Channels	Frequency	Average Power	Peak Power	Maximum System Gain (Antenna + Cable) (dBi)	EIRP (dBm)		Average EIRP FCC Part 20 Limit (dBm)
(MHz)		(MHz)	(dBm)	(dBm)		Average	Peak	
5 MHz	4132	826.4	21.42	29.12	8.58	30	37.7	30
	4183	836.6	21.42	29.32	8.58	30	31.9	30
	4233	846.6	21.23	32.56	8.77	30	41.33	30
15 MHz	4132+4157+4182	826.4+831.4+836.4	21.59	31.44	8.41	30	39.85	30
	4158+4183+4208	831.6+836.6+841.6	21.01	30.87	8.99	30	39.86	30
	4183+4208+4233	836.6+841.6+846.6	<b>21.68</b>	31.62	<b>8.32</b>	30	39.94	30

Power Output (Conducted / EIRP) /Channel WCDMA Band 5 Downlink						
Bandwidth 15(MHz)	Channels	Channel Frequency Under test (MHz)	Average Power /Channel (dBm)	Maximum System Gain (Antenna + Cable) (dBi)	Average EIRP (dBm)	Average EIRP / Channel FCC Part 20 Limit (dBm)
5MHz/Channel	4357+4382+4407	871.4	9.51	0.49	10	10
	4357+4382+4407	876.4	9.23	0.77	10	10
	4357+4382+4407	881.4	9.55	0.45	10	10
5MHz/Channel	4383+4408+4433	876.6	8.71	1.29	10	10
	4383+4408+4433	881.6	9.94	0.06	10	10
	4383+4408+4433	886.6	8.33	1.67	10	10
5MHz/Channel	4408+4433+4458	881.6	9.95	0.05	10	10
	4408+4433+4458	886.6	9.42	0.58	10	10
	4408+4433+4458	891.6	8.74	1.26	10	10



FCC ID: NU: YETQ44-1M34CNU and CU: YETQ41-RECU  
 IC: NU: 9892A-Q441M34CNU and CU: 9892A-Q41RECU

Power Output (Conducted / EIRP) LTE Band 4 Downlink								
Bandwidth (MHz)	Channels	Frequency (MHz)	Average Power (dBm)	Peak Power (dBm)	Maximum System Gain (Antenna + Cable) (dBi)	EIRP (dBm)		Average EIRP FCC Part 20 Limit (dBm)
						Average	Peak	
5	1975	2112.5	15.21	27.29	1.79	17	29.08	17
	2175	2132.5	15.19	27.27	1.81	17	29.08	17
	2375	2152.5	15.15	27.19	1.85	17	29.04	17
10	2000	2115	<b>15.84</b>	27.65	<b>1.16</b>	17	28.81	17
	2175	2132.5	15.12	26.88	1.88	17	28.76	17
	2350	2150	15.02	26.96	1.98	17	28.94	17
15	2025	2117.5	14.52	25.09	2.48	17	27.57	17
	2175	2132.5	14.57	25.69	2.43	17	28.12	17
	2325	2147.5	15.73	26.97	1.27	17	28.24	17
20	2050	2120	15.24	24.94	1.76	17	26.7	17
	2175	2132.5	15.04	24.94	1.96	17	26.9	17
	2300	2145	15.3	24.04	1.7	17	25.74	17

Power Output (Conducted / EIRP) LTE Band 4 Uplink								
Bandwidth (MHz)	Channels	Frequency (MHz)	Average Power (dBm)	Peak Power (dBm)	Maximum System Gain (Antenna + Cable) (dBi)	EIRP (dBm)		Average EIRP FCC Part 20 Limit (dBm)
						Average	Peak	
5	19975	1712.5	21.53	29.82	8.47	30	38.29	30
	20175	1732.5	21.5	29.63	8.5	30	38.13	30
	20375	1752.5	21.45	29.63	8.55	30	38.18	30
10	20000	1715	23.27	32.24	6.73	30	38.97	30
	20175	1732.5	23.27	31.88	6.73	30	38.61	30
	20350	1750	<b>23.37</b>	31.94	<b>6.63</b>	30	38.57	30
15	20025	1717.5	21.94	29.12	8.06	30	37.18	30
	20175	1732.5	21.43	28.54	8.57	30	37.11	30
	20325	1747.5	21.68	28.94	8.32	30	37.26	30
20	20050	1720	21.68	29.61	8.32	30	37.93	30
	20175	1732.5	21.37	29.5	8.63	30	38.13	30
	20300	1745	21.51	29.81	8.49	30	38.3	30



FCC ID: NU: YETQ44-1M34CNU and CU: YETQ41-RECU  
 IC: NU: 9892A-Q441M34CNU and CU: 9892A-Q41RECU

Power Output (Conducted / EIRP) LTE Band 12 Downlink								
Bandwidth	Channels	Frequency	Average Power	Peak Power	Maximum System Gain (Antenna + Cable) Gain (dBi)	EIRP (dBm)		Average EIRP FCC Part 20 Limit (dBm)
(MHz)		(MHz)	(dBm)	(dBm)		Average	Peak	
5	5035	731.5	15.47	27.36	1.53	17	28.89	17
	5095	737.5	15.28	26.77	1.72	17	28.49	17
	5155	743.5	<b>15.56</b>	27.73	<b>1.44</b>	17	29.17	17
10	5060	734	15.51	25.33	1.49	17	26.82	17
	5095	737.5	15.46	27.87	1.54	17	29.41	17
	5130	741	14.79	24.44	2.21	17	26.65	17

Power Output (Conducted / EIRP) LTE Band 12 Uplink								
Bandwidth	Channels	Frequency	Average Power	Peak Power	Maximum System Gain (Antenna + Cable) Gain (dBi)	EIRP (dBm)		Average EIRP FCC Part 20 Limit (dBm)
(MHz)		(MHz)	(dBm)	(dBm)		Average	Peak	
5	23035	701.5	21.59	30.95	8.41	30	39.36	30
	23095	707.5	<b>21.92</b>	31.45	<b>8.08</b>	30	39.53	30
	23155	713.5	21.49	31.15	8.51	30	39.66	30
10	23060	704	21.64	31.77	8.36	30	40.13	30
	23095	707.5	21.9	32.95	8.1	30	41.05	30
	23130	711	21.6	32.08	8.4	30	40.48	30



FCC ID: NU: YETQ44-1M34CNU and CU: YETQ41-RECU  
 IC: NU: 9892A-Q441M34CNU and CU: 9892A-Q41RECU

Power Output (Conducted / EIRP) LTE Band 13 Downlink								
Bandwidth	Channels	Frequency	Average Power	Peak Power	Maximum System Gain (Antenna + Cable) (dBi)	EIRP (dBm)		Average EIRP FCC Part 20 Limit (dBm)
(MHz)		(MHz)	(dBm)	(dBm)		Average	Peak	
5	5205	748.5	15.59	27.65	1.41	17	1.41	17
	5230	751	<b>15.84</b>	27.8	<b>1.16</b>	17	1.16	17
	5255	753.5	15.64	28.08	1.36	17	1.36	17
10	-	-	-	-	-	-	-	-
	5230	751	15.66	28.01	1.34	17	1.34	17
	-	-	-	-	-	-	-	-

Power Output (Conducted / EIRP) LTE Band 13 Uplink								
Bandwidth	Channels	Frequency	Average Power	Peak Power	Maximum System Gain (Antenna + Cable) (dBi)	EIRP (dBm)		Average EIRP FCC Part 20 Limit (dBm)
(MHz)		(MHz)	(dBm)	(dBm)		Average	Peak	
5	23205	779.5	21.47	30.99	8.53	30	39.52	30
	23230	782	21.64	31.1	8.36	30	39.46	30
	23255	784.5	21.67	31.48	8.33	30	39.81	30
10	-	-	-	-	-	-	-	-
	23230	782	<b>22.01</b>	30.13	7.99	30	38.12	30
	-	-	-	-	-	-	-	-



FCC ID: NU: YETQ44-1M34CNU and CU: YETQ41-RECU  
 IC: NU: 9892A-Q441M34CNU and CU: 9892A-Q41RECU

Power Output (Conducted / EIRP) LTE Band 25 Downlink								
Bandwidth (MHz)	Channels	Frequency (MHz)	Average Power (dBm)	Peak Power (dBm)	Maximum System Gain (Antenna + Cable)(dBi)	EIRP Average (dBm)	EIRP Peak (dBm)	Average EIRP FCC Part 20 Limit (dBm)
5 MHz	8065	1932.5	15.04	26.79	1.96	17	28.75	17
	8365	1962.5	15.16	26.79	1.84	17	28.63	17
	8665	1992.5	15.11	26.65	1.89	17	28.54	17
10 MHz	8090	1935	15.2	26.54	1.8	17	28.34	17
	8365	1962.5	14.51	26.78	2.49	17	29.27	17
	8640	1990	15.47	27.75	1.53	17	29.28	17
15 MHz	8115	1937.5	16.15	26.77	0.85	17	27.62	17
	8365	1962.5	16.54	28.09	0.46	17	28.55	17
	8615	1987.5	15.62	26.27	1.38	17	27.65	17
20 MHz	8140	1940	16.07	27.22	0.93	17	28.15	17
	8365	1962.5	15.51	27.34	1.49	17	28.83	17
	8590	1985	<b>16.86</b>	27.7	<b>0.14</b>	17	27.84	17

Power Output (Conducted / EIRP) LTE Band 25 Uplink								
Bandwidth (MHz)	Channels	Frequency (MHz)	Average Power (dBm)	Peak Power (dBm)	Maximum System Gain (Antenna + Cable)(dBi)	EIRP Average (dBm)	EIRP Peak (dBm)	Average EIRP FCC Part 20 Limit (dBm)
5 MHz	26065	1852.5	20.49	31.48	9.51	30	40.99	30
	26365	1882.5	20.73	31.69	9.27	30	40.96	30
	26665	1912.5	21.01	30.79	8.99	30	39.78	30
10 MHz	26090	1855	<b>23.48</b>	32.94	<b>6.52</b>	30	39.46	30
	26365	1882.5	22.33	30.58	7.67	30	38.25	30
	26640	1910	21.41	28.78	8.59	30	37.37	30
15 MHz	26115	1857.5	20.95	29.51	9.05	30	38.56	30
	26365	1882.5	21.66	29.85	8.34	30	38.19	30
	26615	1907.5	21.77	29.85	8.23	30	38.08	30
20 MHz	26140	1860	21.18	29.94	8.82	30	38.76	30
	26365	1882.5	21.64	29.73	8.36	30	38.09	30
	26590	1905	21.48	29.36	8.52	30	37.88	30



FCC ID: NU: YETQ44-1M34CNU and CU: YETQ41-RECU  
 IC: NU: 9892A-Q441M34CNU and CU: 9892A-Q41RECU

2 Bands/port worst case configuration (Downlink)				
Ant Port	Band/Bandwidth/Channel	Frequency (MHz)	Average Power (dBm)	Peak Power (dBm)
A	LTE Band 4 20MHz BW High Ch & LTE Band 12 10MHz BW High Ch	2145.0 MHz + 741.0 MHz	15.92	24.77
	LTE Band 4 20MHz BW High Ch & LTE Band 30 10MHz BW Mid Ch	2145.0 MHz + 2355.0 MHz	16.17	24.6
	LTE Band 25 20MHz BW Mid Ch & LTE Band 12 10MHz BW High Ch	1962.5 MHz + 741.0 MHz	16.18	24.88
	LTE Band 25 20MHz BW Mid Ch & LTE Band 30 10MHz BW Mid Ch	1962.5 MHz + 2355.0 MHz	15.75	23.67
	WCDMA Band 5 15MHz BW Low Ch & LTE Band 12 10MHz BW High Ch	871.4MHz & 876.4MHz & 881.4MHz + 741.0 MHz	17.43	26
	WCDMA Band 5 15MHz BW Low Ch & LTE Band 30 10MHz BW Mid Ch	871.4MHz & 876.4MHz & 881.4MHz + 2355.0 MHz	16.76	26.4

2 Bands/port worst case configuration (Uplink)				
Ant Port	Band/Bandwidth/Channel	Frequency (MHz)	Average Power (dBm)	Peak Power (dBm)
A	LTE Band 4 15MHz BW Low Ch & LTE Band 12 10MHz BW Low Ch	1717.5 MHz + 704.0 MHz	21.48	29.8
	LTE Band 4 15MHz BW Low Ch & LTE Band 30 5MHz BW High Ch	1717.5 MHz + 2312.5 MHz	21.82	29.97
	LTE Band 25 20MHz BW High Ch & LTE Band 12 10MHz BW Low Ch	1905.0 MHz + 704 MHz	21.2	30.9
	LTE Band 25 20MHz BW High Ch & LTE Band 30 5MHz BW High Ch	1905.0 MHz + 2312.5 MHz	22.94	31.43
	WCDMA Band 5 5MHz BW Mid Ch & LTE Band 12 10MHz BW Low Ch	836.6 MHz + 704 MHz	21.39	30.59
	WCDMA Band 5 5MHz BW Mid Ch & LTE Band 30 5MHz BW High Ch	836.6 MHz + 2312.5 MHz	23.07	31.08



FCC ID: NU: YETQ44-1M34CNU and CU: YETQ41-RECU  
 IC: NU: 9892A-Q441M34CNU and CU: 9892A-Q41RECU

2 Bands/port worst case configuration (Downlink)				
Ant Port	Band/Bandwidth/Channel	Frequency (MHz)	Average Power (dBm)	Peak Power (dBm)
B	LTE Band 4 20MHz BW High Ch & LTE Band 71 20MHz BW Low Ch	2145.0 MHz + 627.0.0 MHz	15.52	24.46
	LTE Band 25 20MHz BW Mid Ch & LTE Band 71 20MHz BW Low Ch	1962.5 MHz + 627.0 MHz	15.41	23.72
	LTE Band 4 20MHz BW High Ch & LTE Band 25 20MHz BW Mid Ch	2145.0 MHz + 1962.5 MHz	15.91	25.4

2 Bands/port worst case configuration (Uplink)				
Ant Port	Band/Bandwidth/Channel	Frequency (MHz)	Average Power (dBm)	Peak Power (dBm)
B	LTE Band 4 15MHz BW Low Ch & LTE Band 71 10MHz BW Mid Ch	1717.5 MHz + 680.5 MHz	23.54	31.54
	LTE Band 25 20MHz BW High Ch & LTE Band 71 10MHz BW Mid Ch	1905.0 MHz + 680.5 MHz	21.44	29.57
	LTE Band 4 15MHz BW Low Ch & LTE Band 25 20MHz BW High Ch	1717.5 MHz + 1905.0 MHz	21.83	30.62

2 Bands/port worst case configuration (Downlink)				
Ant Port	Band/Bandwidth/Channel	Frequency (MHz)	Average Power (dBm)	Peak Power (dBm)
C	LTE Band 4 20MHz BW High Ch & LTE Band 71 20MHz BW Low Ch	2145.0 MHz + 627.0.0 MHz	15.52	24.46
	LTE Band 4 20MHz BW High Ch & LTE Band 25 20MHz BW Mid Ch	2145.0 MHz + 1962.5 MHz	15.91	25.4

2 Bands/port worst case configuration (Uplink)				
Ant Port	Band/Bandwidth/Channel	Frequency (MHz)	Average Power (dBm)	Peak Power (dBm)
C	LTE Band 4 15MHz BW Low Ch & LTE Band 71 10MHz BW Mid Ch	1717.5 MHz + 680.5 MHz	23.54	31.54
	LTE Band 4 15MHz BW Low Ch & LTE Band 25 20MHz BW High Ch	1717.5 MHz + 1905.0 MHz	21.83	30.62





FCC ID: NU: YETQ44-1M34CNU and CU: YETQ41-RECU  
 IC: NU: 9892A-Q441M34CNU and CU: 9892A-Q41RECU

### 2.3.10 Test Results (Conducted Power)

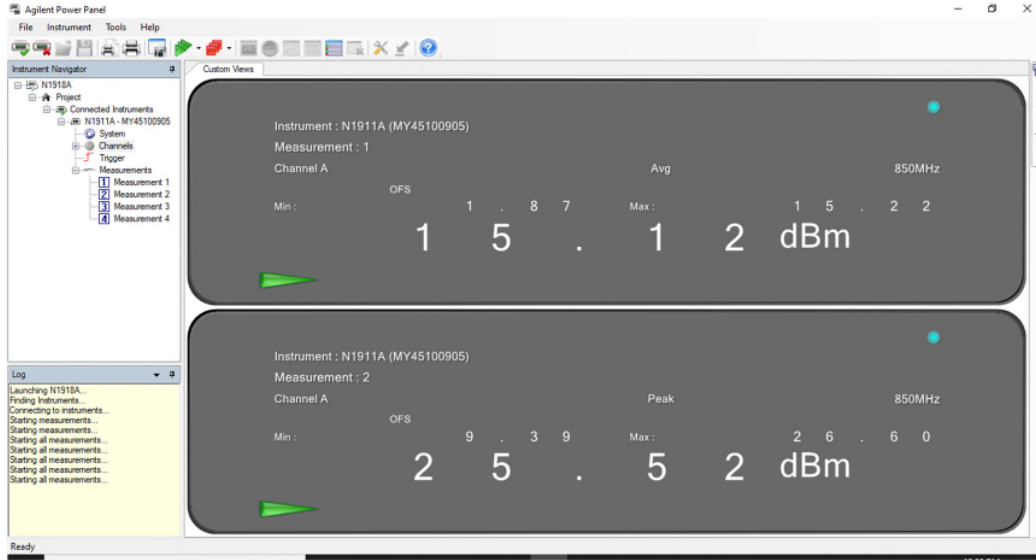

**WCDMA Band 5\_DownLink\_5MHz Bandwidth\_Mid Channel**

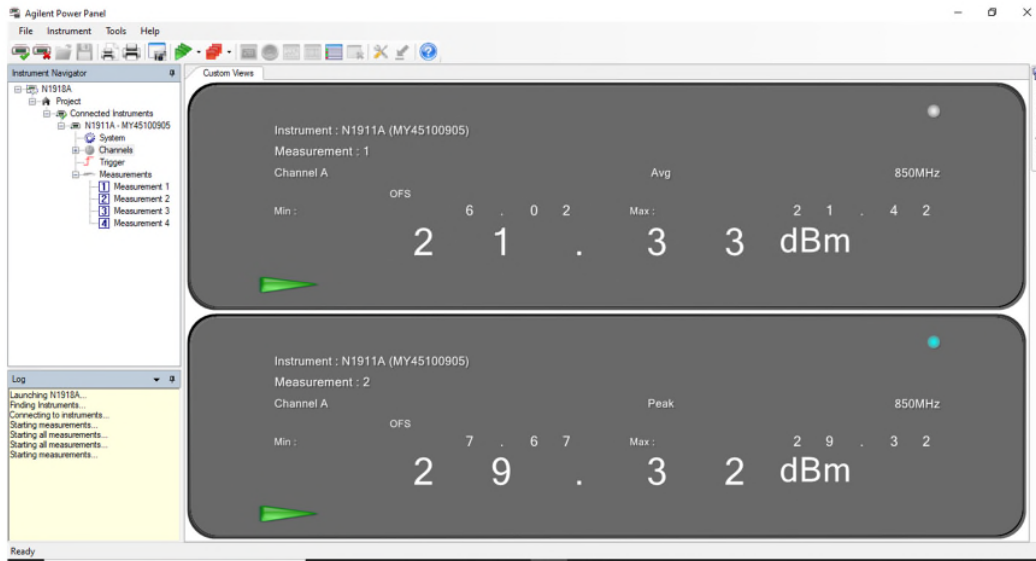

**WCDMA Band 5\_UpLink\_5MHz Bandwidth\_Mid Channel**



FCC ID: NU: YETQ44-1M34CNU and CU: YETQ41-RECU  
IC: NU: 9892A-Q441M34CNU and CU: 9892A-Q41RECU

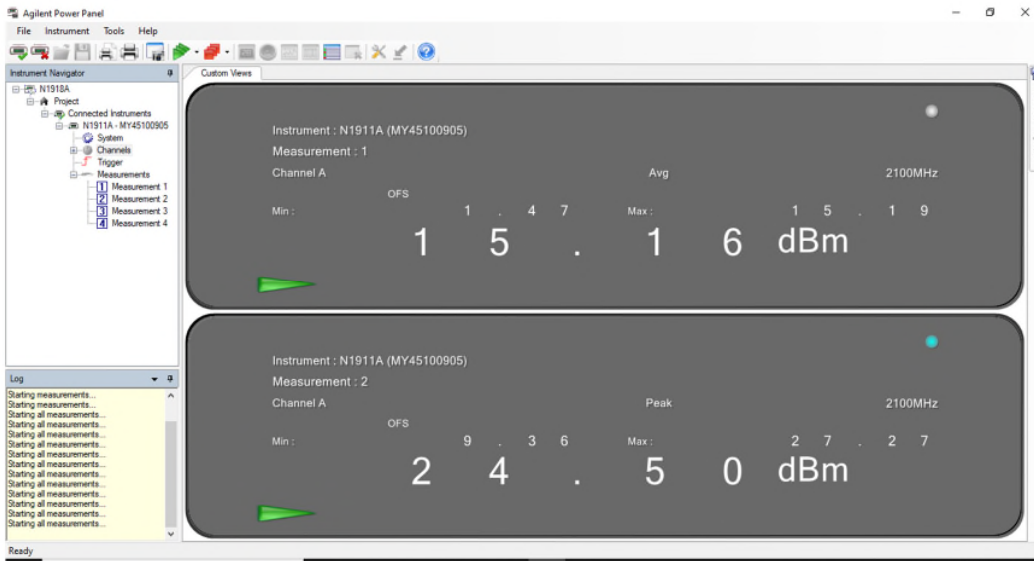

**LTE Band 4 DL 5 MHz Bandwidth Middle Channel**

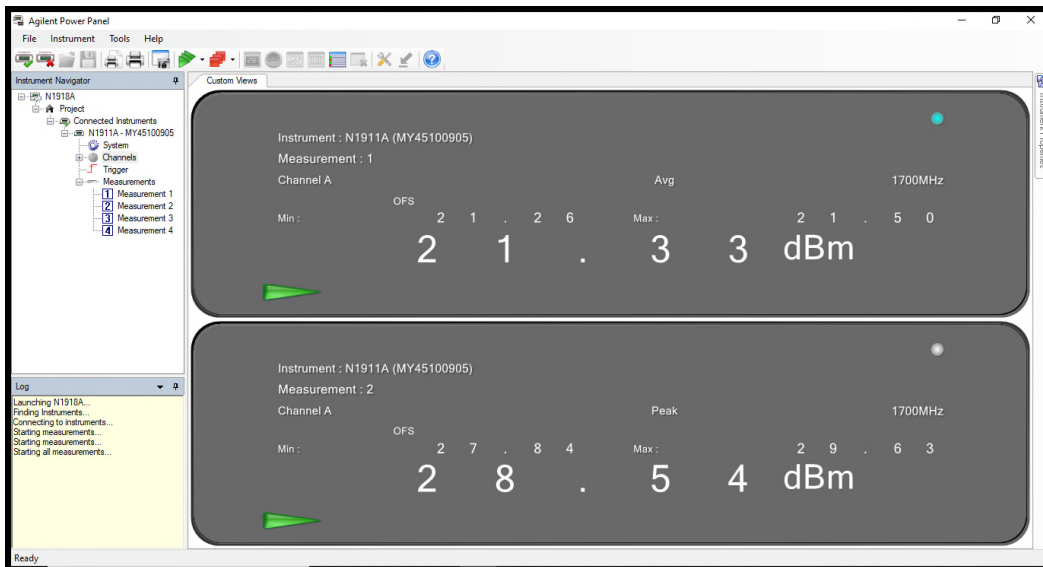

**LTE Band 4 UL 5 MHz Bandwidth Middle Channel**



FCC ID: NU: YETQ44-1M34CNU and CU: YETQ41-RECU  
IC: NU: 9892A-Q441M34CNU and CU: 9892A-Q41RECU

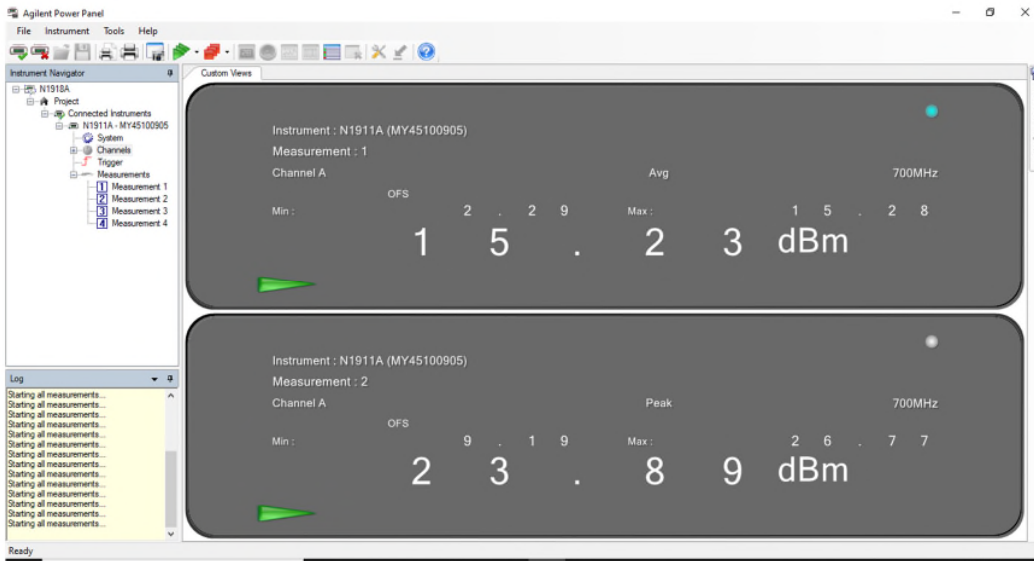

LTE Band 12 DL 5 MHz Bandwidth Middle Channel

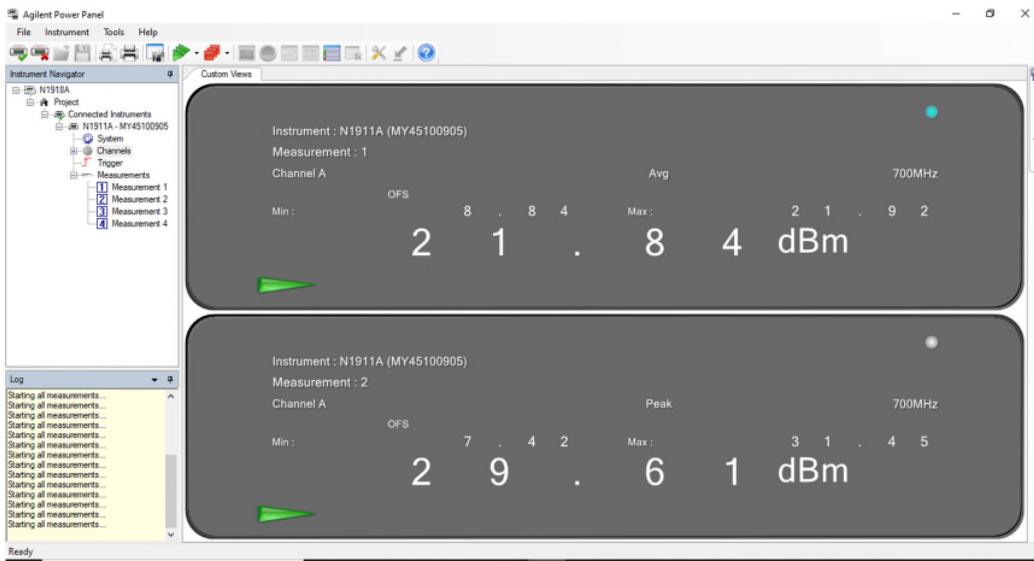

LTE Band 12 UL 5 MHz Bandwidth Middle Channel



FCC ID: NU: YETQ44-1M34CNU and CU: YETQ41-RECU  
IC: NU: 9892A-Q441M34CNU and CU: 9892A-Q41RECU

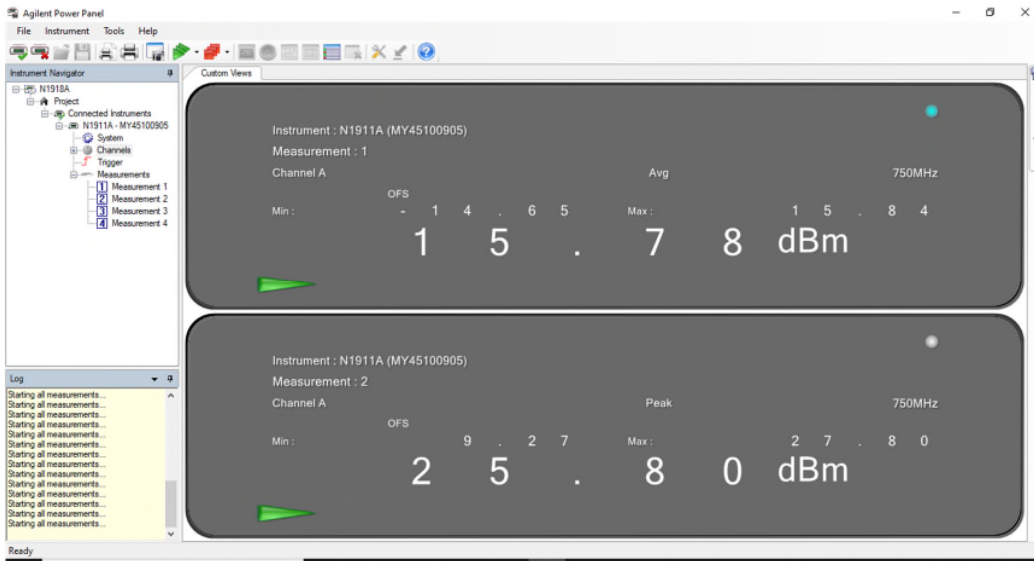

LTE Band 13 DL 5 MHz Bandwidth Middle Channel

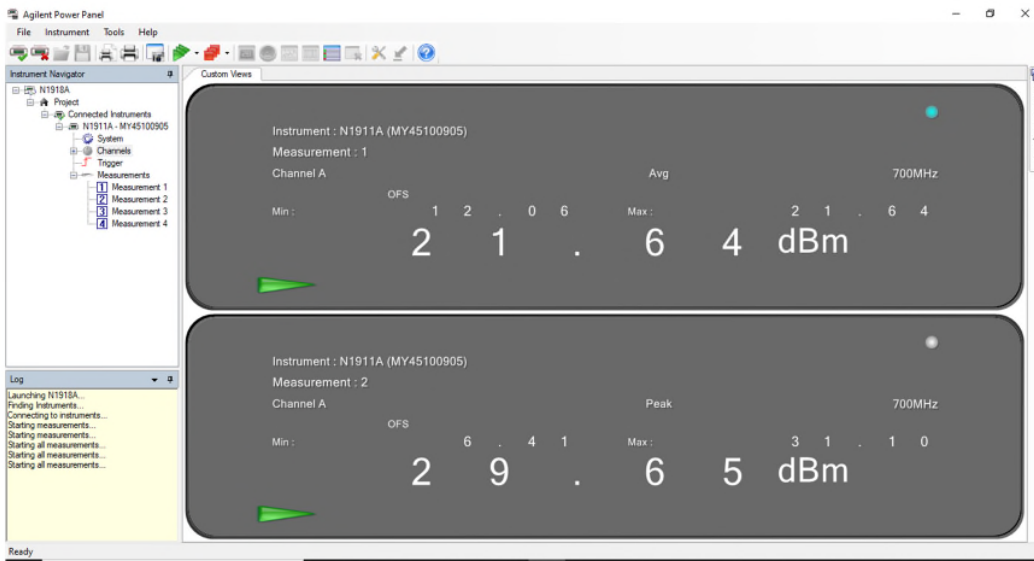

LTE Band 13 UL 5 MHz Bandwidth Middle Channel