

Radio Testing of the

Nextivity Inc.

Industrial Signal Booster

Model: Cel-Fi QUATRA

Q34-2/12/14/66NU_EXA (NU)

Q34-2/12/14/66CU_EXA (CU)

In accordance with

FCC CFR 47 Part 24, 27

RSS-133 issue 6 Amendment 1 (January 2018)

RSS-130 issue 2 (February 2019)

RSS-131 issue 3 (May 2017)

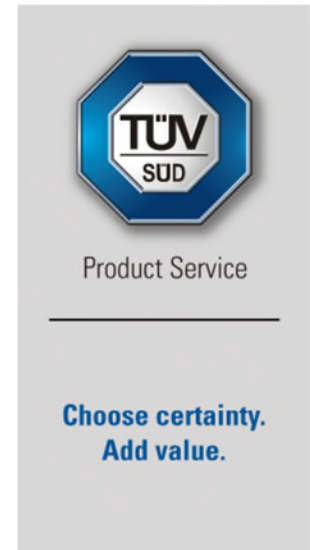

Nextivity Inc.

16550 West Bernardo Drive, Bldg 5, Suite 550,
San Diego, CA 92127, USA

Date: November 2020

Document Number: 72162443A Issue 01 | Version Number: 01

RESPONSIBLE FOR	NAME	DATE	SIGNATURE
Authorized Signatory	Alex Chang	November 17, 2020	<i>Alex Chang</i>

Signatures in this approval box have checked this document in line with the requirements of TÜV SÜD Product Service document control rules.

EXECUTIVE SUMMARY

The EUT in general was confirmed to be in compliance with FCC CFR 47 Part 24, 27, RSS-133 issue 6 Amendment 1 (January 2018), RSS-130 issue 2 (February 2019) and RSS-131 issue 3 (May 2017).



A2LA Cert. No. 2955.13

DISCLAIMER AND COPYRIGHT

This non-binding report has been prepared by TÜV SÜD Product Service with all reasonable skill and care. The document is confidential to the potential Client and TÜV SÜD Product Service. No part of this document may be reproduced without the prior written approval of TÜV SÜD Product Service. © 2016 TÜV SÜD Product Service.

ACCREDITATION

Our A2LA Accreditation does not cover opinions and interpretations and any expressed are outside the scope of our A2LA Accreditation.

TÜV SÜD America, Inc.
10040 Mesa Rim Road
San Diego, CA 92121-2912

TÜV SÜD America, Inc.
Rancho Bernardo Facility
16936 Via Del Campo
San Diego, CA 92127

Phone: 858 678 1400

www.tuv-sud-america.com



America

TÜV SÜD America Inc., 10040 Mesa Rim Road, San Diego, CA 92121
Tel: (858) 678-1400. Website: www.TUVamerica.com

REPORT ON	Radio Testing of the Nextivity Inc. Cel-Fi QUATRA Industrial Signal Booster
TEST REPORT NUMBER	72162443A
REPORT DATE	November 2020
PREPARED FOR	Nextivity Inc. 16550 West Bernardo Drive, Bldg 5, Suite 550, San Diego, CA 92127, USA
CONTACT PERSON	CK Li Sr. Principal Engineer, Regulatory (858) 485-9422 CLi@NextivityInc.com
PREPARED BY	 Xiaoying Zhang <hr/> Name Authorized Signatory Title: EMC/Wireless Test Engineer



America

TÜV SÜD America Inc., 10040 Mesa Rim Road, San Diego, CA 92121
Tel: (858) 678-1400. Website: www.TUVamerica.com

Revision History

72162443A Nextivity Inc. Cel-Fi QUATRA Industrial Signal Booster					
DATE	OLD REVISION	NEW REVISION	REASON	PAGES AFFECTED	APPROVED BY
11/17/2020	—	Initial Release			Alex Chang



CONTENTS

Section	Page No
1	REPORT SUMMARY 4
1.1	Introduction 5
1.2	Brief Summary Of Results 7
1.3	Product Information 8
1.4	EUT Test Configuration 11
1.5	Deviations From The Standard..... 15
1.6	Modification Record 15
1.7	Test Methodology 15
1.8	Test Facility Location 15
1.9	Test Facility Registration 15
2	TEST DETAILS 17
2.1	Transmitter Conducted Output Power 18
2.2	Effective Isotropic Radiated Power..... 25
2.3	Effective Radiated Power 29
2.4	Occupied Bandwidth..... 32
2.5	Peak-Average Ratio..... 57
2.6	Band Edge 64
2.7	Conducted Spurious Emissions..... 86
2.8	Field Strength of Spurious Radiation..... 98
2.9	Frequency Stability 124
2.10	AGC Threshold Level 132
2.11	Out-Of-Band Rejection 134
2.12	Input-Versus-Output Signal Comparison..... 139
2.13	Mean Output Power And Amplifier/Booster Gain 166
2.14	Out-Of-Band/Out-Of-Block (Intermodulation) And Spurious Emissions..... 168
3	TEST EQUIPMENT USED 187
3.1	Test Equipment Used 188
3.2	Measurement Uncertainty 189
4	DIAGRAM OF TEST SETUP 191
4.1	Test Setup Diagram..... 192
5	ACCREDITATION, DISCLAIMERS AND COPYRIGHT..... 195
5.1	Accreditation, Disclaimers And Copyright 196



SECTION 1

REPORT SUMMARY

Radio Testing of the
Nextivity Inc.
Cel-Fi QUATRA Industrial Signal Booster



1.1 INTRODUCTION

The information contained in this report is intended to show verification of the Nextivity Inc. Cel-Fi QUATRA to the requirements of FCC CFR 47 Part 24, 27, RSS-133 issue 6 Amendment 1 (January 2018), RSS-130 issue 2 (February 2019) and RSS-131 issue 3 (May 2017).

Objective	To perform Radio Testing to determine the Equipment Under Test's (EUT's) compliance with the Test Specification, for the series of tests carried out.
Manufacturer	Nextivity Inc.
EUT	Industrial Signal Booster
Model Name	Cel-Fi QUATRA
Model Number(s)	Q34-2/12/14/66NU_EXA (NU) Q34-2/12/14/66CU_EXA (CU)
FCC ID	NU: YETQ34-2121466NU CU: YETQ34-2121466CU
IC ID	N/A
Serial Number(s)	NU: 976036000256 CU: 977036000055
Number of Samples Tested	2
Date sample(s) received	September 25, 2020
Test Specification/Issue/Date	<ul style="list-style-type: none"> • FCC CFR 47 Part 24, 27 (October 1, 2019) • RSS-133 - 2 GHz Personal Communications Services (issue 6, Amendment 1, January 2018) • RSS-130 - Equipment Operating in the Frequency Bands 617-652 MHz, 663-698 MHz, 698-756 MHz and 777-787 MHz (issue 2, February 2019) • RSS-131 – Zone Enhancers (issue 3, Updated May 2017) • SRSP-510 - Technical Requirements for Personal Communications Services (PCS) in the bands 1850-1915 MHz and 1930-1995 MHz (issue 5, Feb. 2009) • SRSP-518 - Technical Requirements in the Bands 617-652 MHz, 663-698 MHz, 698-756 MHz and 777-787 MHz (Issue 2, February 2019). • RSS-Gen - General Requirements for Compliance of Radio Apparatus (Issue 5, November 2019 Amendment 1). • ANSI C63.26-2015: American National Standard for Compliance Testing of Transmitters Used in Licensed Radio Services
Start of Test	September 26, 2020
Finish of Test	October 15, 2020
Name of Engineer(s)	Xiaoying Zhang



America

Related Document(s)

- KDB971168 D01 Power Meas License Digital Systems v03r01 (Measurement Guidance For Certification of Licensed Digital Transmitters)
- KDB412172 D01 Determining ERP and EIRP v01r01 (Guidelines for Determining the Effective Radiated Power (ERP) and Equivalent Isotropically Radiated Power (EIRP) of a RF Transmitting System)
- KDB662911 D01 Multiple Transmitter Output v02r01 (Emissions Testing of Transmitters with Multiple Outputs in the Same Band)
- Supporting documents for EUT certification are separate exhibits.

1.2 BRIEF SUMMARY OF RESULTS

A brief summary of the tests carried out in accordance with FCC CFR 47 Part 24, 27 with cross-reference to Innovation, Science and Economic Development Canada Interference-Causing Equipment Standards is shown below:

Section	Part 2	Part 24/27/90	RSS-133	RSS-130	Test Description	Result
2.1	2.1046	-	-	-	Transmitter Conducted Output Power	Compliant
2.2	-	24.232(a)(2) 27.50 (h)(1)	6.4	6.5	Equivalent Isotropic Radiated Power	Compliant
2.3	-	27.50 (c)(3)	-	4.6.3	Equivalent Radiated Power	Compliant
2.4	2.1049	-	RSS-GEN 6.7		Occupied Bandwidth	Compliant
2.5	-	24.232(d) 27.50 (d)(5)	6.4	4.6.1	Peak-Average Ratio	Compliant
2.6	2.1051	24.238(a)(b) 27.53 (h)(1)(3) 27.53 (g)	6.5	4.7	Band Edge	Compliant
2.7	2.1051	24.238(a)(b) 27.53 (h)(1)(3) 27.53 (g)	6.5	4.7	Conducted Spurious Emissions	Compliant
2.8	2.1053	24.238(a) 27.53 (h)(1)(3) 27.53 (g)	6.5	4.7	Field Strength of Spurious Radiation	Compliant
2.9	2.1055	24.235 27.54	6.3	4.5	Frequency Stability	Compliant
-	-	-	RSS-Gen 7.1		Receiver Spurious Emissions	N/A

N/A Not required as per RSS-GEN 5.3. EUT is not a Stand-alone receiver.

Section	Spec Clause			Test Description	Result
	FCC Part 20	KDB 935210 D05	RSS-131		
2.10	20.21 (c)	3.2	-	AGC Threshold Level	Compliant
2.11		3.3	5.2.1	Out-of-Band rejection	Compliant
2.12		3.4	5.2.2	Input-versus-Output Signal Comparison	Compliant
2.13		3.5	5.2.3	Mean Output Power and Amplifier/Booster Gain	Compliant
2.14		3.6	-	Out-of-band/out-of-block (Intermodulation) and Spurious Emissions	Compliant
-		3.7	-	Frequency Stability	Refer to Section 2.9
-		3.8	-	Spurious Emissions Radiated Measurement	Refer to Section 2.8

1.3 PRODUCT INFORMATION

1.3.1 Technical Description

The Equipment Under Test (EUT) was a Nextivity Inc. Cel-Fi QUATRA Industrial Signal Booster. The EUT is a Public Safety LTE Signal Booster to improve voice and data cellular performance in large enterprise environments. QUATRA consists of two separate units: The Network Unit (NU), and the Coverage Unit (CU). The NU comprises a transmitter and receiver which communicate with the cell tower and the CU. Figure 1 illustrates the typical application. The CU is a self-contained unit with internal antennas. It operates without the need to install external antennas. However, external antenna ports are available as an option on CU. NU uses external antennas only. External antenna or MicroCell donor signal input can be connected to these ports.

LTE Band 2, 4 and 12 functions of the EUT were verified in this test report.

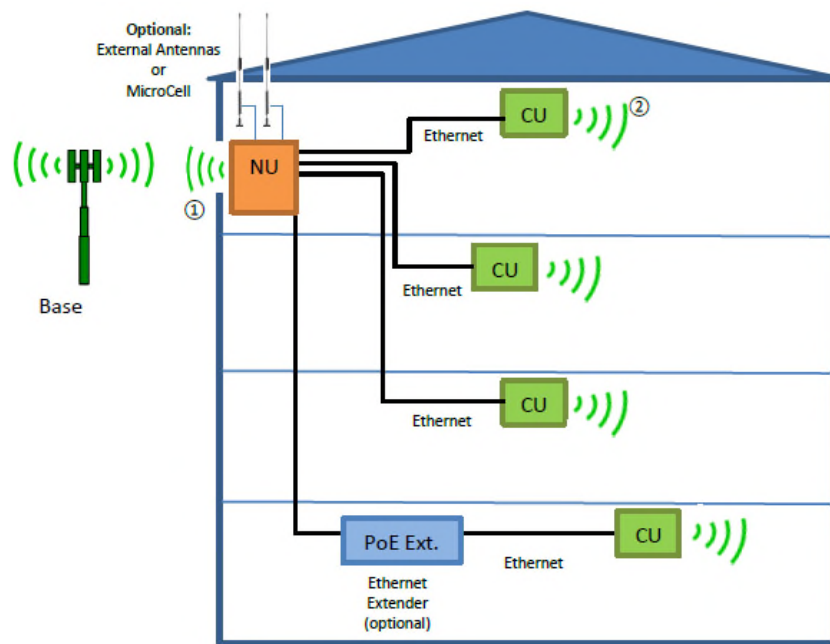

Figure 1: Cel-Fi QUATRA Connections



1.3.2 EUT General Description

EUT Description Industrial Signal Booster

Trade Name Cel-Fi™

Model Name Cel-Fi QUATRA

Model Number(s) Q34-2/12/14/66NU_EXA (NU)
Q34-2/12/14/66CU_EXA (CU)

Rated Voltage NU: 54V DC via external AC/DC Power Supply
CU: 48V DC, powered from NU via Ethernet cable

Mode Verified LTE Band 2, 4, 12

Frequency Bands
 LTE Band 2: Uplink: 1850 - 1910 MHz
 Downlink: 1930 - 1990 MHz
 LTE Band 4: Uplink: 1710 - 1755 MHz
 Downlink: 2110 - 2155 MHz
 LTE Band 12: Uplink: 699 - 716 MHz
 Downlink: 729 - 746 MHz

Product Specifications

Band	Signal Bandwidth (MHz)	Rated Power (dBm)	
		Downlink	Uplink
2	5 – 20	10 dBm / 5MHz (Max. 16)	22
4	5 – 20	10 dBm / 5MHz (Max. 16)	22
12	5 – 10	10 dBm / 5MHz (Max. 13)	20

Power Tolerance ± 2 dB

Capability LTE (Band 2, 4, 12 and 14)

Primary Unit (EUT) Production
 Pre-Production
 Engineering

Environment Fixed, Indoor

Manufacturer Declared Temperature Range 0°C to 40°C

Antenna Type NU: External MIMO Antenna
CU: Internal or External MIMO Antenna

Antenna Model Refer to the Antenna information supplied by the manufacture

Antenna gain Refer to the Antenna information supplied by the manufacture

Maximum Antenna Gain

Radio	Uplink (Donor)	Downlink (Server)
LTE Band 2	8.5 dBi	9.0 dBi
LTE Band 4	8.5 dBi	9.0 dBi
LTE Band 12	6.5 dBi	6.5 dBi

1.3.3 Transmit Frequency Table

Mode	Channel Bandwidth (MHz)	Tx Frequency (MHz)	Emission Designator	EIRP		ERP	
				Max. Power Avg (dBm)	Max. Power Avg (W)	Max. Power Avg (dBm)	Max. Power Avg (W)
LTE Band 2 Downlink	5	1930 - 1995	4M50F9W	22.35	0.17	-	-
	10	1930 - 1995	8M78F9W	24.69	0.29	-	-
	15	1930 - 1995	13M3F9W	26.91	0.49	-	-
	20	1930 - 1995	18M0F9W	28.77	0.75	-	-
LTE Band 2 Uplink	5	1850 - 1915	4M41F9W	33.50	2.24	-	-
	10	1850 - 1915	8M77F9W	33.19	2.08	-	-
	15	1850 - 1915	13M3F9W	33.37	2.17	-	-
	20	1850 - 1915	17M7F9W	34.04	2.54	-	-
LTE Band 4 Downlink	5	2110 - 2155	4M45F9W	22.30	0.17	-	-
	10	2110 - 2155	8M79F9W	24.90	0.30	-	-
	15	2110 - 2155	13M3F9W	26.64	0.46	-	-
	20	2110 - 2155	18M0F9W	28.43	0.70	-	-
LTE Band 4 Uplink	5	1710 - 1755	4M42F9W	35.08	3.22	-	-
	10	1710 - 1755	8M78F9W	34.72	2.96	-	-
	15	1710 - 1755	13M3F9W	34.96	3.13	-	-
	20	1710 - 1755	17M7F9W	35.44	3.50	-	-
LTE Band 12 Downlink	5	729 - 746	4M42F9W	-	-	18.18	0.07
	10	729 - 746	8M78F9W	-	-	20.25	0.11
LTE Band 12 Uplink	5	699 - 716	4M42F9W	-	-	28.24	0.67
	10	699 - 716	8M78F9W	-	-	27.87	0.61

1.4 EUT TEST CONFIGURATION

1.4.1 Test Configuration Description

Test Configuration	Description
A	Downlink. Input signal is applied to the external antenna port of Donor (NU). Output is monitored from the internal antenna port of Server (CU).
B	Uplink. Input signal is applied to the internal antenna port of Server (CU). Output is monitored from the external antenna port of Donor (NU).
C	Radiated test setup. Downlink. Input signal is applied to the external antenna port of Donor (NU). The internal antenna ports of Server (CU) are terminated with 50Ω loads.
D	Radiated test setup. Uplink. Input signal is applied to the internal antenna port of Server (CU). The antenna ports of Donor (NU) are terminated with 50Ω loads.

1.4.2 EUT Exercise Software

Manufacturer provided a configuration software (ConformanceTest.exe) running from a support laptop where both NU and CU are connected via USB.

1.4.3 Support Equipment and I/O cables

Manufacturer	Equipment/Cable	Description
Lenovo	Support Laptop	M/N: 2912-3VU, S/N: R9-92MH0 10/11
Lenovo	Support Laptop AC Adapter	M/N: 42T4430 S/N: 11S42T4430Z1ZGWE27AA9X
Nextivity	Support USB cable x 2	Custom 1.0 meter shielded USB Type A to Micro B cable
Nextivity	Support USB cable x 1	Custom 1.0 meter shielded USB Type A to Micro A cable
Nextivity	Support Ethernet cable x 1	Custom 2.0 meter unshielded CAT 5e Ethernet Cables
Agilent	Vector Signal Generator	M/N: SMBV100A, S/N: 259021
Aeroflex	Signal Generator	M/N: 3005, S/N: 3005A/09L
Ramsey	Support Shielded Test Enclosure	With custom USB cable

1.4.4 Worst Case Configuration

Worst-case configuration used in this test report per Transmitter Conducted Output Power (Section 2.1 of this test report). This is for single channel verification, otherwise all three channels (Low, Middle and High) are verified:

Mode	Bandwidth	Channel No.	Frequency
LTE Band 2 Downlink	20MHz	Middle Channel 900	1960 MHz
LTE Band 2 Uplink	20MHz	Low Channel 18700	1860 MHz
LTE Band 4 Downlink	20MHz	Low Channel 2050	2120 MHz
LTE Band 4 Uplink	20MHz	High Channel 20300	1745 MHz
LTE Band 12 Downlink	10MHz	Low Channel 5060	734 MHz
LTE Band 12 Uplink	5MHz	Low Channel 23035	701.5 MHz

Final installation position is unknown at the time of verification. For radiated measurements X and Z orientations were verified since the EUT won't work on Y orientation. No major variation in emissions observed between the three (3) orientations. Verifications performed using "X" configuration.

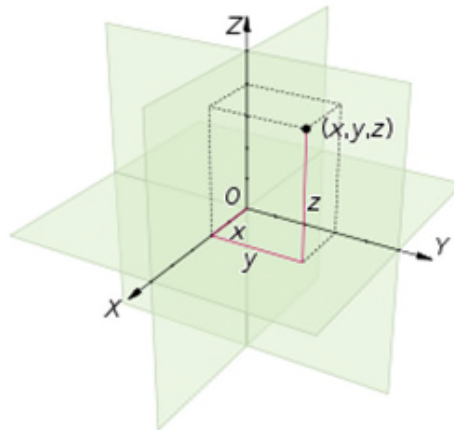

1.4.5 Simplified Test Configuration Diagram

Downlink (CU Tx) Conducted Test

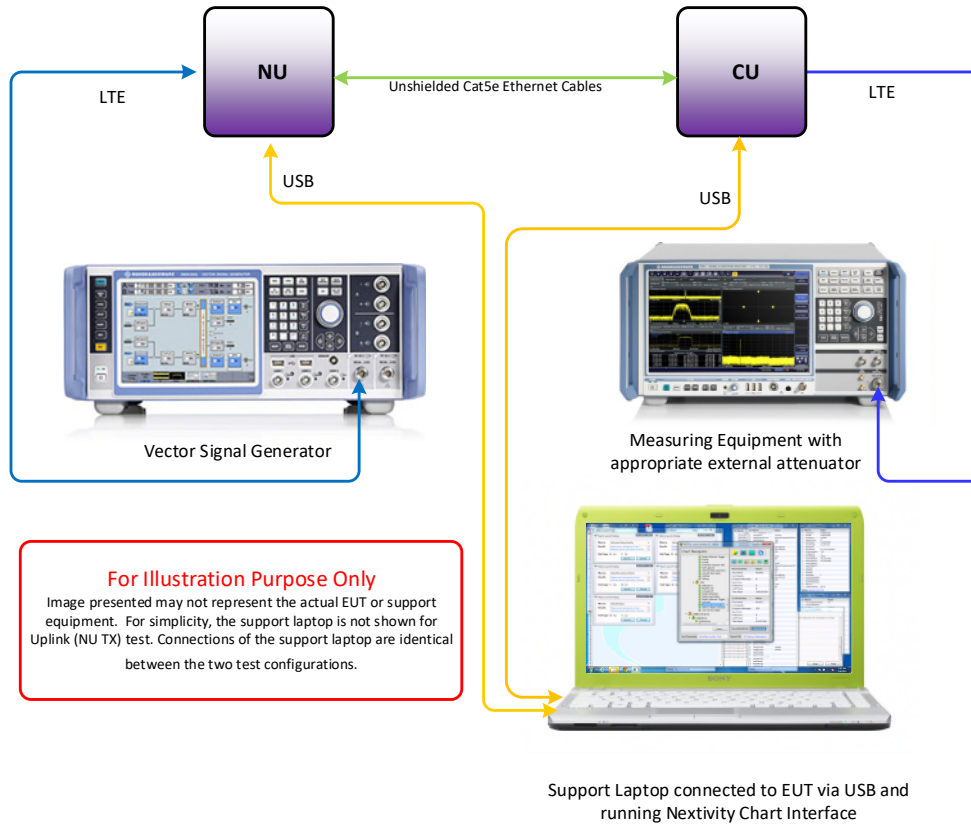

For Illustration Purpose Only

Image presented may not represent the actual EUT or support equipment. For simplicity, the support laptop is not shown for Uplink (NU TX) test. Connections of the support laptop are identical between the two test configurations.

Uplink (NU Tx) Conducted Test

Monitoring the output can be done simultaneously (2 SA) or single output

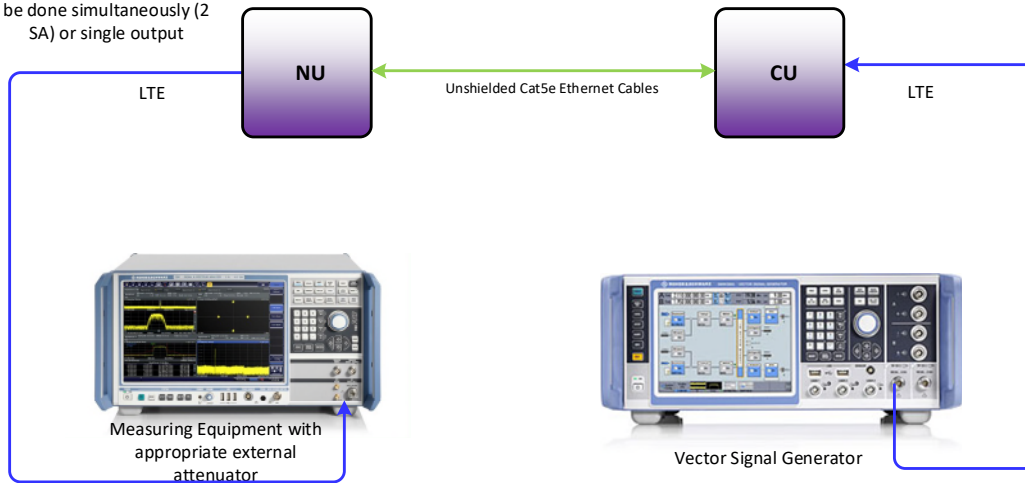

Radiated Testing (Downlink)

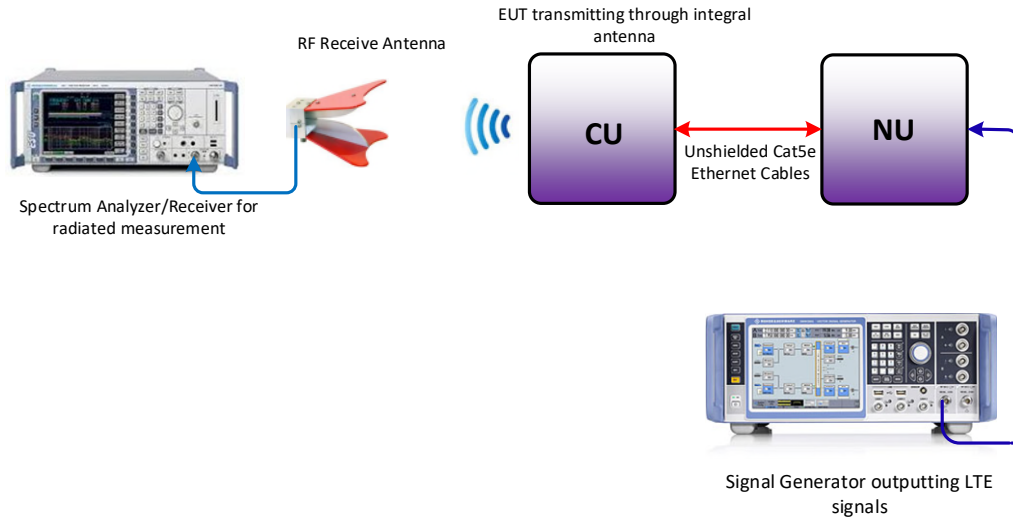

Radiated Testing (Uplink)

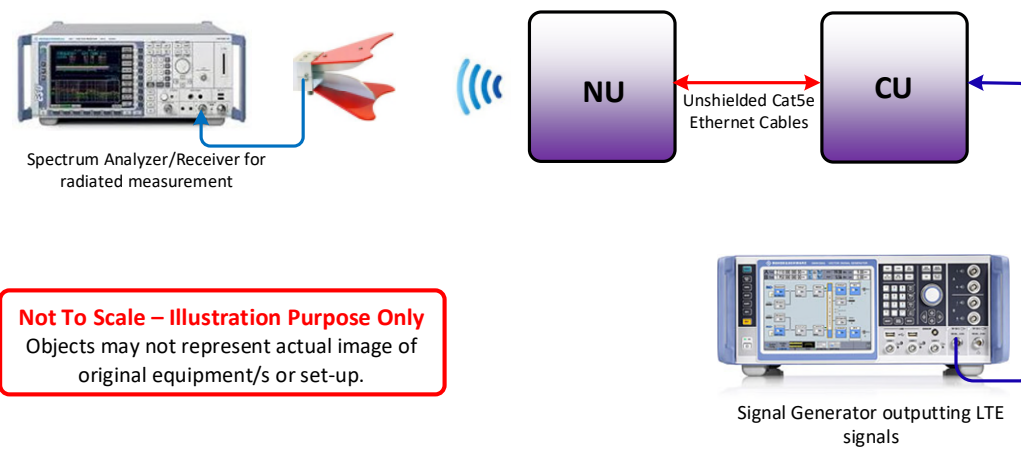

Not To Scale – Illustration Purpose Only
Objects may not represent actual image of original equipment/s or set-up.



1.5 DEVIATIONS FROM THE STANDARD

No deviations from the applicable test standards or test plan were made during testing.

1.6 MODIFICATION RECORD

Description of Modification	Modification Fitted By	Date Modification Fitted
Serial Number: NU: 976036000256 and CU: 977036000055		
None	-	-

The table above details modifications made to the EUT during the test program. The modifications incorporated during each test (if relevant) are recorded on the appropriate test pages.

1.7 TEST METHODOLOGY

All measurements contained in this report were conducted with ANSI C63.26 2015, American National Standard for Compliance Testing of Transmitters Used in Licensed Radio Services

For conducted (if applicable) and radiated emissions the equipment under test (EUT) was configured to measure its highest possible emission level. This level was based on the maximized cable configuration from exploratory testing per ANSI C63.26-2015. The test modes were adapted according to the Operating Instructions provided by the manufacturer/client.

1.8 TEST FACILITY LOCATION

1.8.1 TÜV SÜD America Inc. (Mira Mesa)

10040 Mesa Rim Road, San Diego, CA 92121-2912 (32.901268,-117.177681). Phone: (858) 678 1400 Fax: (858) 546 0364.

1.8.2 TÜV SÜD America Inc. (Rancho Bernardo)

16936 Via Del Campo, San Diego, CA 92127-1708 (33.018644,-117.092409). Phone: (858) 678 1400 Fax: (858) 546 0364.

1.9 TEST FACILITY REGISTRATION

1.9.1 FCC – Designation No.: US1146

TÜV SÜD America Inc. (San Diego), is an accredited test facility with the site description report on file and has met all the requirements specified in §2.948 of the FCC rules. The acceptance letter from the FCC is maintained in our files and the Designation is US1146.



1.9.2 Innovation, Science and Economic Development Canada (ISED) Registration No.: 3067A-1 & 22806-1

The 10m Semi-anechoic chamber of TÜV SÜD America Inc. (San Diego Rancho Bernardo) has been registered by Certification and Engineering Bureau of Innovation, Science and Economic Development Canada for radio equipment testing with Registration No. 3067A-1.

The 3m Semi-anechoic chamber of TÜV SÜD America Inc. (San Diego Mira Mesa) has been registered by Certification and Engineering Bureau of Innovation, Science and Economic Development Canada for radio equipment testing with Registration No. 22806-1.

1.9.3 BSMI – Laboratory Code: SL2-IN-E-028R (US0102)

TÜV Product Service Inc. (San Diego) is a recognized EMC testing laboratory by the BSMI under the MRA (Mutual Recognition Arrangement) with the United States. Accreditation includes CNS 13438 up to 6GHz.

1.9.4 NCC (National Communications Commission - US0102)

TÜV SÜD America Inc. (San Diego) is listed as a Foreign Recognized Telecommunication Equipment Testing Laboratory and is accredited to ISO/IEC 17025 (A2LA Certificate No.2955.13) which under APEC TEL MRA Phase 1 was designated as a Conformity Assessment Body competent to perform testing of equipment subject to the Technical Regulations covered under its scope of accreditation including RTTE01, PLMN01 and PLMN08 for TTE type of testing and LP0002 for Low-Power RF Device type of testing.

1.9.5 VCCI – Registration No. A-0280 and A-0281

TÜV SÜD America Inc. (San Diego) is a VCCI registered measurement facility which includes radiated field strength measurement, radiated field strength measurement above 1GHz, mains port interference measurement and telecommunication port interference measurement.

1.9.6 RRA – Identification No. US0102

TÜV SÜD America Inc. (San Diego) is National Radio Research Agency (RRA) recognized laboratory under Phase I of the APEC Tel MRA.

1.9.7 OFCA – U.S. Identification No. US0102

TÜV SÜD America Inc. (San Diego) is recognized by Office of the Communications Authority (OFCA) under Appendix B, Phase I of the APEC Tel MRA.



SECTION 2

TEST DETAILS

Radio Test of the
Nextivity Inc.
Cel-Fi QUATRA Industrial Signal Booster



2.1 TRANSMITTER CONDUCTED OUTPUT POWER

2.1.1 Specification Reference

FCC 47 CFR Part 2, Clause 2.1046

2.1.2 Standard Applicable

The conducted power measurements were made in accordance to FCC Part 2 Clause 2.1046:

(a) For transmitters other than single sideband, independent sideband and controlled carrier radiotelephone, power output shall be measured at the RF output terminals when the transmitter is adjusted in accordance with the tune-up procedure to give the values of current and voltage on the circuit elements specified in §2.1033(c)(8). The electrical characteristics of the radio frequency load attached to the output terminals when this test is made shall be stated.

(c) For measurements conducted pursuant to paragraphs (a) and (b) of this section, all calculations and methods used by the applicant for determining carrier power or peak envelope power, as appropriate, on the basis of measured power in the radio frequency load attached to the transmitter output terminals shall be shown. Under the test conditions specified, no components of the emission spectrum shall exceed the limits specified in the applicable rule parts as necessary for meeting occupied bandwidth or emission limitations.

2.1.3 Equipment Under Test and Modification State

Serial No: NU: 976036000256 and CU: 977036000055 / Test Configuration A and B

2.1.4 Date of Test/Initial of test personnel who performed the test

September 26, 27 and October 12, 2020 / XYZ

2.1.5 Test Equipment Used

The major items of test equipment used for the above tests are identified in Section 3.1.

2.1.6 Environmental Conditions/ Test Location

Test performed at TÜV SÜD America Inc. Rancho Bernardo facility

Ambient Temperature	21.8 - 23.2 °C
Relative Humidity	47.5 - 51.6 %
ATM Pressure	98.7 - 98.9 kPa

2.1.7 Additional Observations

- This is a conducted test using power meter.
- The path loss was measured and entered as a level offset.
- Both Peak and Average measurements presented.
- EUT Downlink transmits on two internal antennas and uplink transmits on two external antennas simultaneously in the same frequency range, i.e. TX MIMO mode. However, there is no much difference between two antenna ports and the measurement was performed on one antenna port as representative configuration. The total conducted average output power was adjusted with a correction of 3 dB [10Log(2)] by using Measure and Add 10Log(N) dB

technique according to FCC KDB 662911 D01 Multiple Transmitter Output accounting for simultaneous transmission from two internal or external antenna ports.

- LTE Band 2, 4 support 5 MHz to 20 MHz bandwidths, and LTE Band 12 supports 5 MHz and 10 MHz bandwidths.
- Low, Middle and High channels for supporting bandwidths were verified and reported.

2.1.8 Test Results

LTE Band 2 Downlink					
Bandwidth (MHz)	Channels	Frequency (MHz)	Average Power (dBm)	Peak Power (dBm)	Total Average Power of MIMO Ports (dBm)
5 MHz	625	1932.5	10.10	20.64	13.10
	900	1960.0	10.33	22.84	13.33
	1175	1987.5	10.35	20.01	13.35
10 MHz	650	1935.0	12.69	23.08	15.69
	900	1960.0	12.17	24.49	15.17
	1150	1985.0	12.67	23.85	15.67
15 MHz	675	1937.5	14.63	24.72	17.63
	900	1960.0	14.91	25.15	17.91
	1125	1982.5	14.43	24.67	17.43
20 MHz	700	1940.0	16.44	25.0	19.44
	900	1960.0	16.77	25.24	19.77
	1100	1980.0	16.17	24.47	19.17

LTE Band 2 Uplink					
Bandwidth (MHz)	Channels	Frequency (MHz)	Average Power (dBm)	Peak Power (dBm)	Total Average Power of MIMO Ports (dBm)
5 MHz	18625	1852.5	22.0	28.95	25.0
	18900	1880.0	21.60	28.53	24.60
	19175	1907.5	21.64	28.25	24.64
10 MHz	18650	1855.0	21.69	28.64	24.69
	18900	1880.0	21.30	28.08	24.30
	19150	1905.0	21.02	27.82	24.02
15 MHz	18675	1857.5	21.87	32.25	24.87
	18900	1880.0	21.42	32.38	24.42
	19125	1902.5	21.39	31.43	24.39
20 MHz	18700	1860.0	22.54	29.54	25.54
	18900	1880.0	22.15	29.43	25.15
	19100	1900.0	22.31	29.95	25.31



LTE Band 4 Downlink					
Bandwidth (MHz)	Channels	Frequency (MHz)	Average Power (dBm)	Peak Power (dBm)	Total Average Power of MIMO Ports (dBm)
5 MHz	1975	2112.5	10.22	18.97	13.22
	2175	2132.5	10.30	18.38	13.30
	2375	2152.5	10.12	18.28	13.12
10 MHz	2000	2115.0	12.59	21.31	15.59
	2175	2132.5	12.90	21.17	15.90
	2350	2150.0	12.70	21.77	15.70
15 MHz	2025	2117.5	14.60	24.69	17.60
	2175	2132.5	14.64	26.18	17.64
	2325	2147.5	14.60	24.76	17.60
20 MHz	2050	2120.0	16.43	24.47	19.43
	2175	2132.5	16.31	24.69	19.31
	2300	2145.0	16.34	24.97	19.34

LTE Band 4 Uplink					
Bandwidth (MHz)	Channels	Frequency (MHz)	Average Power (dBm)	Peak Power (dBm)	Total Average Power of MIMO Ports (dBm)
5 MHz	19975	1712.5	23.46	29.95	26.46
	20175	1732.5	23.35	29.82	26.35
	20375	1752.5	23.58	30.14	26.58
10 MHz	20000	1715.0	23.20	29.85	26.20
	20175	1732.5	23.01	29.61	26.01
	20350	1750.0	23.22	29.71	26.22
15 MHz	20025	1717.5	23.22	32.34	26.22
	20175	1732.5	23.20	32.23	26.20
	20325	1747.5	23.46	32.20	26.46
20 MHz	20050	1720.0	23.92	30.94	26.92
	20175	1732.5	23.75	30.53	26.75
	20300	1745.0	23.94	30.71	26.94



LTE Band 12 Downlink					
Bandwidth (MHz)	Channel	Frequency (MHz)	Average Power (dBm)	PK Power (dBm)	Total Average Power of MIMO Ports (dBm)
5	5035	731.5	10.83	18.32	13.83
	5095	737.5	10.31	23.23	13.31
	5155	743.5	10.68	18.41	13.68
10	5060	734.0	12.90	20.40	15.90
	5095	737.5	12.32	19.79	15.32
	5130	741.0	12.77	20.17	15.77

LTE Band 12 Uplink					
Bandwidth (MHz)	Channel	Frequency (MHz)	Average Power (dBm)	PK Power (dBm)	Total Average Power of MIMO Ports (dBm)
5	23035	701.5	20.89	31.18	23.89
	23095	707.5	20.79	31.75	23.79
	23155	713.5	20.57	31.23	23.57
10	23060	704.0	20.52	30.95	23.52
	23095	707.5	20.24	30.87	23.24
	23130	711.0	20.28	30.97	23.28



2.1.9 Sample Test Plot

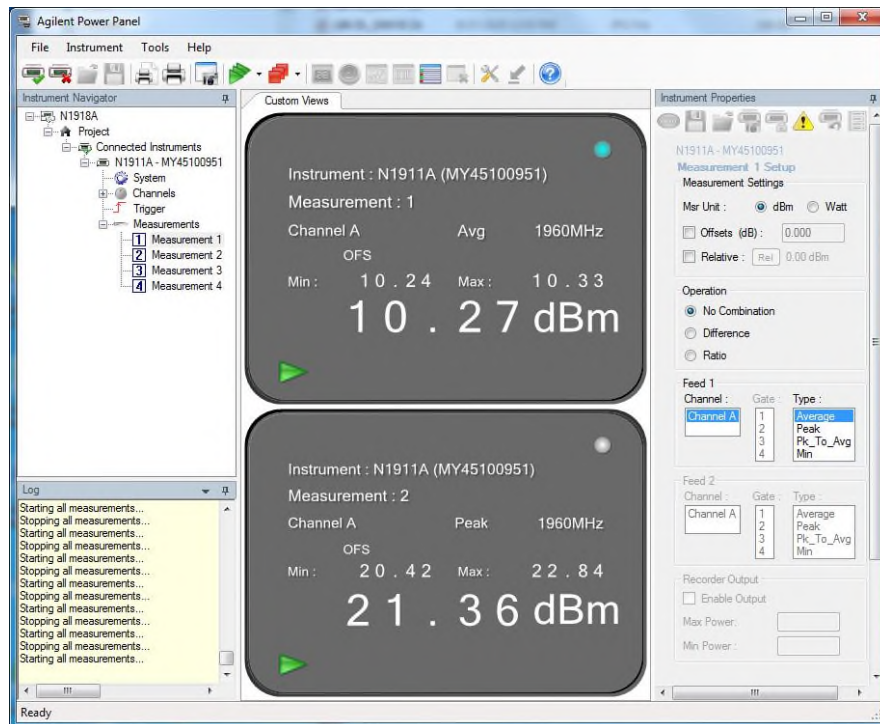

LTE Band 2 DL 5 MHz Bandwidth Middle Channel

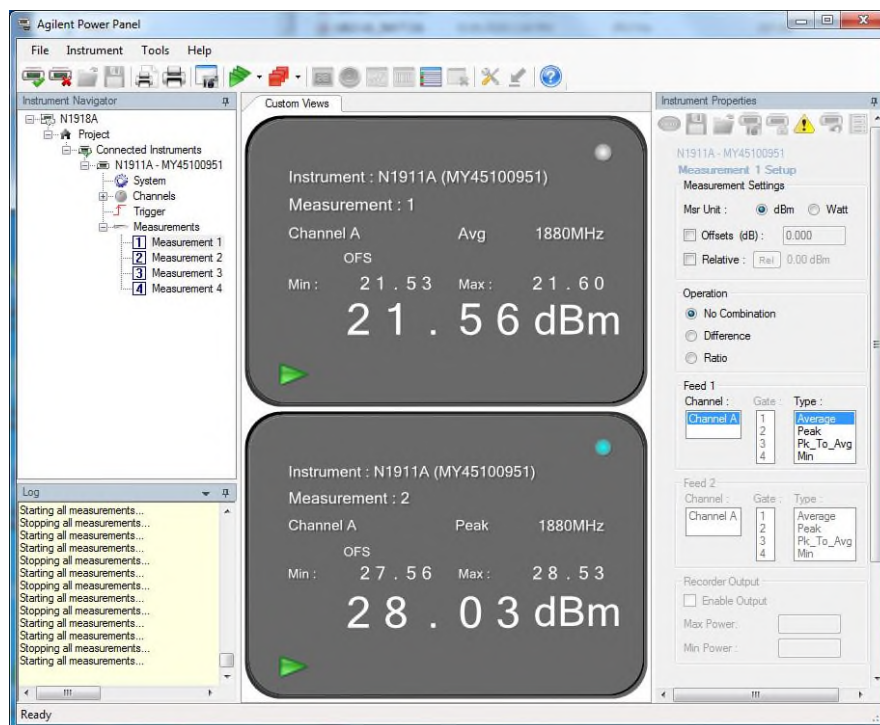

LTE Band 2 UL 5 MHz Bandwidth Middle Channel

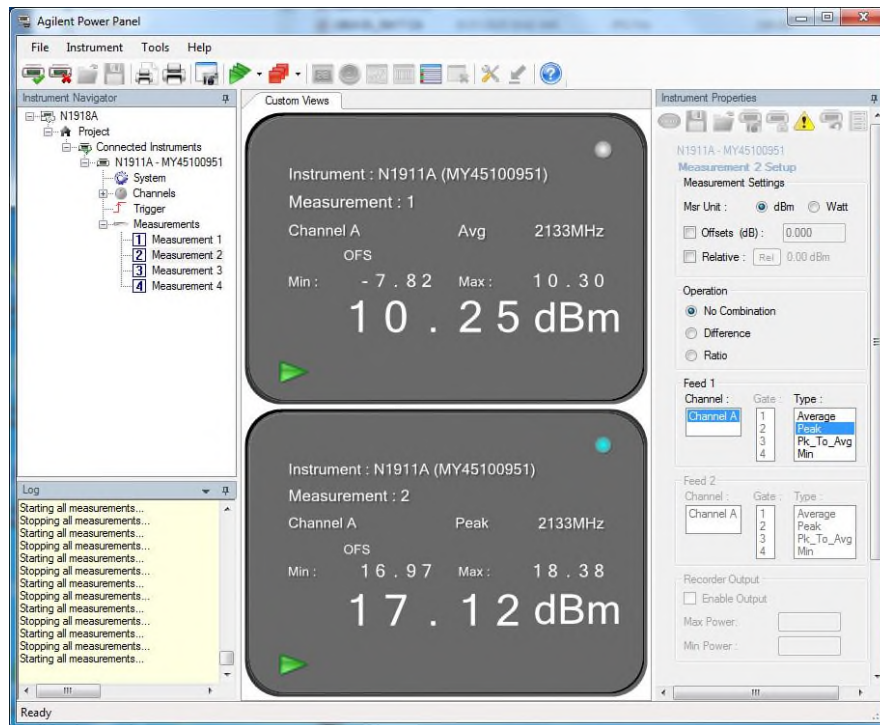

LTE Band 4 DL 5 MHz Bandwidth Middle Channel

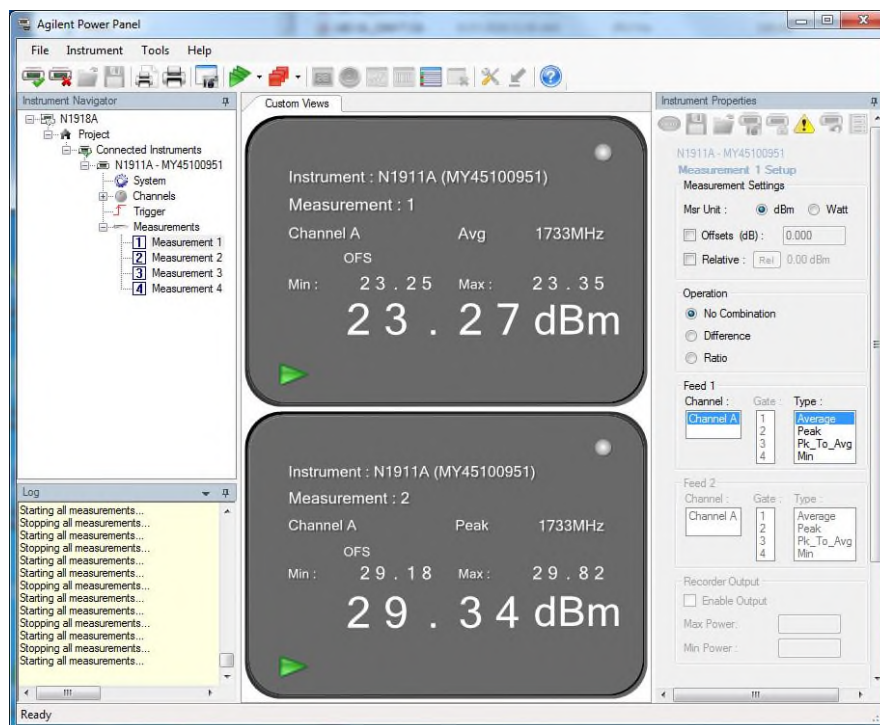

LTE Band 4 UL 5 MHz Bandwidth Middle Channel



America

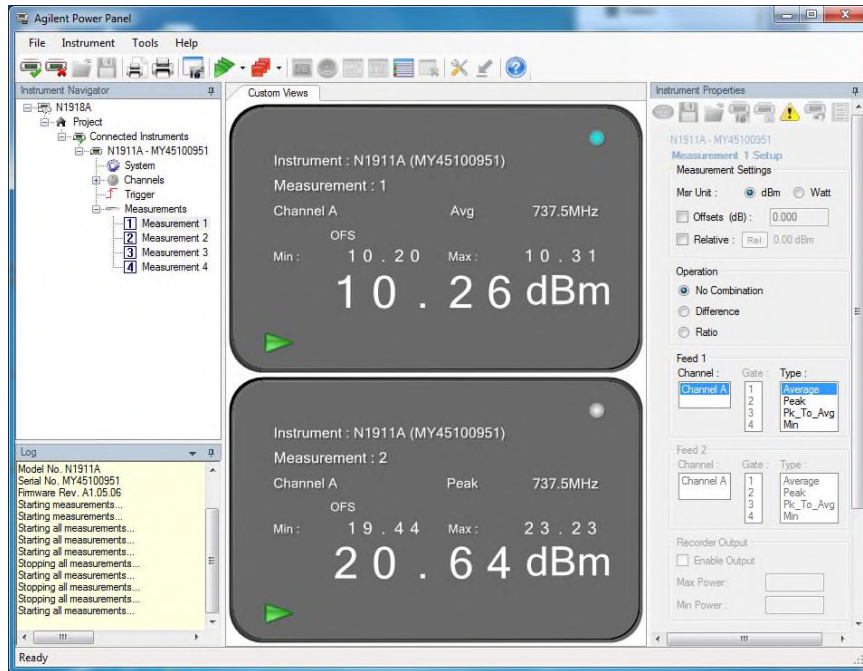

LTE Band 12 DL 5 MHz Bandwidth Middle Channel

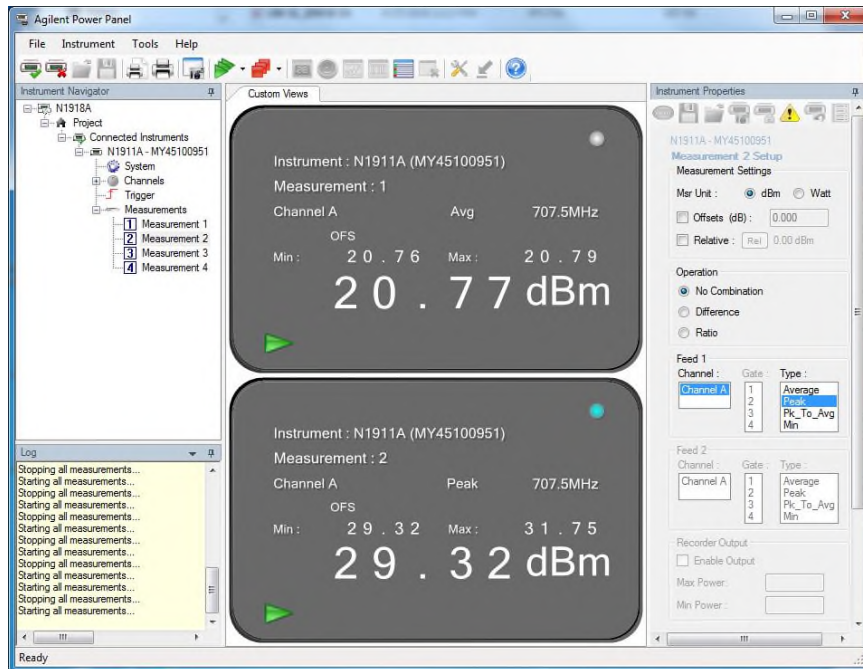

LTE Band 12 UL 5 MHz Bandwidth Middle Channel



2.2 EFFECTIVE ISOTROPIC RADIATED POWER

2.2.1 Specification Reference

FCC 47 CFR Part 24, Clause 24.232(a)(2)
 FCC 47 CFR Part 27, Clause 27.50(h)(1)
 RSS-133 issue 6, Clause 6.4

2.2.2 Standard Applicable

FCC 47 CFR Part 24, Clause 24.232(a)
 (2) Base stations with an emission bandwidth greater than 1 MHz are limited to 1640 watts/MHz equivalent isotropically radiated power (EIRP) with an antenna height up to 300 meters HAAT, except as described in paragraph (b).

FCC 47 CFR Part 27, Clause 27.50 (h):

(1) Main, booster and base stations. (i) The maximum EIRP of a main, booster or base station shall not exceed $33 \text{ dBW} + 10 \log(X/Y) \text{ dBW}$, where X is the actual channel width in MHz and Y is either 6 MHz if prior to transition or the station is in the MBS following transition or 5.5 MHz if the station is in the LBS and UBS following transition, except as provided in paragraph (h)(1)(ii) of this section.

(ii) If a main or booster station sectorizes or otherwise uses one or more transmitting antennas with a non-omnidirectional horizontal plane radiation pattern, the maximum EIRP in dBW in a given direction shall be determined by the following formula: $\text{EIRP} = 33 \text{ dBW} + 10 \log(X/Y) \text{ dBW} + 10 \log(360/\text{beamwidth}) \text{ dBW}$, where X is the actual channel width in MHz, Y is either (i) 6 MHz if prior to transition or the station is in the MBS following transition or (ii) 5.5 MHz if the station is in the LBS and UBS following transition, and beamwidth is the total horizontal plane beamwidth of the individual transmitting antenna for the station or any sector measured at the half-power points.

RSS-133, Clause 6.4:

The equivalent isotropically radiated power (e.i.r.p.) for transmitters shall not exceed the limits given in SRSP-510.

2.2.3 Equipment Under Test and Modification State

Serial No: NU: 976036000256 and CU: 977036000055 (Calculation only)

2.2.4 Date of Test/Initial of test personnel who performed the test

September 26, 27 and October 12, 2020 / XYZ

2.2.5 Test Equipment Used

The major items of test equipment used for the above tests are identified in Section 3.1.

2.2.6 Environmental Conditions/ Test Location

Test performed at TÜV SÜD America Inc. Rancho Bernardo facility

Ambient Temperature	21.8 - 23.2 °C
Relative Humidity	47.5 - 51.6 %
ATM Pressure	98.7 - 98.9 kPa



2.2.7 Additional Observations

- EIRP was calculated as per Section 1.3 of KDB412172 D01 (Determining ERP and EIRP v01).
- Calculation formula in logarithmic terms:

$$\text{EIRP} = P_T + G_T - L_C$$

Where:

P_T = transmitter conducted output power dBm (Section 2.1 of this test report)

G_T = gain of the transmitting antenna, in dBi (EIRP);

L_C = signal attenuation in the connecting cable between the transmitter and antenna, in dB.

- Since the EUT Downlink transmits on two internal antennas simultaneously in the same frequency range, i.e. TX MIMO mode, the total EIRP was adjusted with a correction of 3 dB [$10\text{Log}(2)$] by using Measure and Add $10\text{Log}(N)$ dB technique according to FCC KDB 662911 D01 Multiple Transmitter Output accounting for simultaneous transmission from two internal antenna ports.

2.2.8 Sample Computation

$$\begin{aligned}\text{EIRP} &= P_T + G_T - L_C \\ &= 29.87 \text{ (Peak)} + 0.13 \text{ (max. gain)} - 3.84 \text{ (cable loss)} \\ &= 26.16 \text{ dBm}\end{aligned}$$

2.2.9 Test Results

LTE Band 2 Downlink						
Bandwidth (MHz)	Frequency (MHz)	Max Power Average (dBm)	Antenna Gain (dBi)	EIRP (dBm)	Total EIRP of MIMO Ports (dBm)	Limit (dBm)
5	1932.5	10.10	9.0	19.10	22.10	62.1
	1960.0	10.33	9.0	19.33	22.33	62.1
	1987.5	10.35	9.0	19.35	22.35	62.1
10	1935.0	12.69	9.0	21.69	24.69	62.1
	1960.0	12.17	9.0	21.17	24.17	62.1
	1985.0	12.67	9.0	21.67	24.67	62.1
15	1937.5	14.63	9.0	23.63	26.63	62.1
	1960.0	14.91	9.0	23.91	26.91	62.1
	1982.5	14.43	9.0	23.43	26.43	62.1
20	1940.0	16.44	9.0	25.44	28.44	62.1
	1960.0	16.77	9.0	25.77	28.77	62.1
	1980.0	16.17	9.0	25.17	28.17	62.1

LTE Band 2 Uplink						
Bandwidth (MHz)	Frequency (MHz)	Max Power Average (dBm)	Antenna Gain (dBi)	EIRP (dBm)	Total EIRP of MIMO Ports (dBm)	Limit (dBm)
5	1852.5	22.0	8.5	31.0	33.50	62.1
	1880.0	21.60	8.5	30.60	33.10	62.1
	1907.5	21.64	8.5	30.64	33.14	62.1
10	1855.0	21.69	8.5	30.69	33.19	62.1
	1880.0	21.30	8.5	30.30	32.80	62.1
	1905.0	21.02	8.5	30.02	32.52	62.1
15	1857.5	21.87	8.5	30.87	33.37	62.1
	1880.0	21.42	8.5	30.42	32.92	62.1
	1902.5	21.39	8.5	30.39	32.89	62.1
20	1860.0	22.54	8.5	31.54	34.04	62.1
	1880.0	22.15	8.5	31.15	33.65	62.1
	1900.0	22.31	8.5	31.31	33.81	62.1



LTE Band 4 Downlink (FCC Market only)						
Bandwidth (MHz)	Frequency (MHz)	Max Power Average (dBm)	Antenna Gain (dBi)	EIRP (dBm)	Total EIRP of MIMO Ports (dBm)	Limit (dBm)
5	2112.5	10.22	9.0	19.22	22.22	62.2
	2132.5	10.30	9.0	19.30	22.30	62.2
	2152.5	10.12	9.0	19.12	22.12	62.2
10	2115.0	12.59	9.0	21.59	24.59	65.2
	2132.5	12.90	9.0	21.90	24.90	65.2
	2150.0	12.70	9.0	21.70	24.70	65.2
15	2117.5	14.60	9.0	23.60	26.60	67.0
	2132.5	14.64	9.0	23.64	26.64	67.0
	2147.5	14.60	9.0	23.60	26.60	67.0
20	2120.0	16.43	9.0	25.43	28.43	68.2
	2132.5	16.31	9.0	25.31	28.31	68.2
	2145.0	16.34	9.0	25.34	28.34	68.2

LTE Band 4 Uplink (FCC Market only)						
Bandwidth (MHz)	Frequency (MHz)	Max Power Average (dBm)	Antenna Gain (dBi)	EIRP (dBm)	Total EIRP of MIMO Ports (dBm)	Limit (dBm)
5	1712.5	23.46	8.5	31.96	34.96	62.2
	1732.5	23.35	8.5	31.85	34.85	62.2
	1752.5	23.58	8.5	32.08	35.08	62.2
10	1715.0	23.20	8.5	31.70	34.70	65.2
	1732.5	23.01	8.5	31.51	34.51	65.2
	1750.0	23.22	8.5	31.72	34.72	65.2
15	1717.5	23.22	8.5	31.72	34.72	67.0
	1732.5	23.20	8.5	31.70	34.70	67.0
	1747.5	23.46	8.5	31.96	34.96	67.0
20	1720.0	23.92	8.5	32.42	35.42	68.2
	1732.5	23.75	8.5	32.25	35.25	68.2
	1745.0	23.94	8.5	32.44	35.44	68.2



2.3 EFFECTIVE RADIATED POWER

2.3.1 Specification Reference

FCC 47 CFR Part 27, Clause 27.50(c)(3)
 RSS-130 issue 2, Clause 4.6.3

2.3.2 Standard Applicable

FCC 47 CFR Part 27, Clause 27.50 (c):
 (3) Fixed and base stations transmitting a signal within an emission bandwidth greater than 1 MHz must not exceed an ERP of 1000 watts/MHz and an antenna height of 305 m HAAT, except that antenna height greater than 305 m HAAT ar permitted if power levels are reduced below 1000 watts/MHz ERP in accordance with Table 3 of this section.

TABLE 3 TO § 27.50—PERMISSIBLE POWER AND ANTENNA HEIGHTS FOR BASE AND FIXED STATIONS IN THE 600 MHz, 698–757 MHz, 758–763 MHz, 776–787 MHz AND 788–793 MHz BANDS TRANSMITTING A SIGNAL WITH AN EMISSION BANDWIDTH GREATER THAN 1 MHz

Antenna height (AAT) in meters (feet)	Effective radiated power (ERP) per MHz (watts/MHz)
Above 1372 (4500)	65
Above 1220 (4000) To 1372 (4500)	70
Above 1067 (3500) To 1220 (4000)	75
Above 915 (3000) To 1067 (3500)	100
Above 763 (2500) To 915 (3000)	140
Above 610 (2000) To 763 (2500)	200
Above 458 (1500) To 610 (2000)	350
Above 305 (1000) To 458 (1500)	600
Up to 305 (1000)	1000

RSS-130:
 Clause 4.6.3 Frequency bands 698-756 MHz and 777-787 MHz
 The e.r.p. shall not exceed 30 watts for mobile equipment and outdoor fixed subscriber equipment. The e.r.p. shall not exceed 3 watts for portable equipment and indoor fixed subscriber equipment.

For base and fixed equipment other than fixed subscriber equipment, refer to SRSP-518 for the e.i.r.p. limits.

2.3.3 Equipment Under Test and Modification State

Serial No: NU: 976036000256 and CU: 977036000055 (Calculation only)

2.3.4 Date of Test/Initial of test personnel who performed the test

September 26, 27 and October 12, 2020 / XYZ

2.3.5 Test Equipment Used

The major items of test equipment used for the above tests are identified in Section 3.1.



2.3.6 Environmental Conditions/ Test Location

Test performed at TÜV SÜD America Inc. Rancho Bernardo facility

Ambient Temperature	21.8 - 23.2 °C
Relative Humidity	47.5 - 51.6 %
ATM Pressure	98.7 - 98.9 kPa

2.3.7 Additional Observations

- ERP and EIRP were calculated as per Section 1.2 and 1.3 of KDB412172 D01 (Determining ERP and EIRP v01).
- Calculation formula in logarithmic terms:

$$\text{ERP or EIRP} = P_T + G_T - L_C$$

Where:

P_T = transmitter output power, expressed in dBm (Section 2.1 of this test report)

G_T = gain of the transmitting antenna, in dBd (ERP) or dBi (EIRP);

$G_T(\text{dBd}) = G_T(\text{dBi}) - 2.15 \text{ dB}$

L_C = signal attenuation in the connecting cable between the transmitter and antenna, in dB.

- Since the EUT Downlink transmits on two internal antennas simultaneously in the same frequency range, i.e. TX MIMO mode, the total ERP was adjusted with a correction of 3 dB [10Log(2)] by using Measure and Add 10Log(N) dB technique according to FCC KDB 662911 D01 Multiple Transmitter Output accounting for simultaneous transmission from two internal antenna ports.

2.3.8 Sample Computation

$$\begin{aligned} \text{ERP} &= P_T + G_T - L_C - 2.15\text{dB} \\ &= 29.87 \text{ (Peak)} + 0.13 \text{ (max. gain)} - 3.84 \text{ (cable loss)} - 2.15 \\ &= 24.01 \text{ dBm} \end{aligned}$$

2.3.9 Test Results

LTE Band 12 Downlink						
Bandwidth (MHz)	Frequency (MHz)	Max Power Average (dBm)	Antenna Gain (dBi)	ERP (dBm)	Total ERP of MIMO Ports (dBm)	Limit (dBm)
5	731.5	10.83	6.5	15.18	18.18	44.77
	737.5	10.31	6.5	14.66	17.66	44.77
	743.5	10.68	6.5	15.03	18.03	44.77
10	734.0	12.90	6.5	17.25	20.25	44.77
	737.5	12.32	6.5	16.67	19.67	44.77
	741.0	12.77	6.5	17.12	20.12	44.77

LTE Band 12 Uplink						
Bandwidth (MHz)	Frequency (MHz)	Max Power Average (dBm)	Antenna Gain (dBi)	ERP (dBm)	Total ERP of MIMO Ports (dBm)	Limit (dBm)
5	701.5	20.89	6.5	25.24	28.24	44.77
	707.5	20.79	6.5	25.14	28.14	44.77
	713.5	20.57	6.5	24.92	27.92	44.77
10	704.0	20.52	6.5	24.87	27.87	44.77
	707.5	20.24	6.5	24.59	27.59	44.77
	711.0	20.28	6.5	24.63	27.63	44.77



2.4 OCCUPIED BANDWIDTH

2.4.1 Specification Reference

FCC 47 CFR Part 2. Clause 2.1049
RSS-GEN Issue 5, Clause 6.7

2.4.2 Standard Applicable

The transmitted signal bandwidth shall be reported as the 99% emission bandwidth, that is the frequency bandwidth such that, below its lower and above its upper frequency limits, the mean powers radiated are each equal to 0.5 percent of the total mean power radiated by a given emission.

26dB Bandwidth is defined as the width of the signal between two points, one below the carrier center frequency and one above the carrier center frequency, outside of which all emissions are attenuated by at least 26 dB below the transmitter power.

Using the occupied bandwidth measurement function in the spectrum analyzer, the 99% occupied bandwidth was measured.

In addition, the 26dB bandwidth was measured in accordance with FCC KDB 971168 D01 V0301 Clause 4.1 using the ndB measurement function in the spectrum analyzer.

- The transmitter shall be operated at its maximum carrier power measured under normal test conditions.
- The span of the analyzer shall be set to capture all products of the modulation process, including the emission skirts.
- The resolution bandwidth (RBW) shall be in the range of 1% to 5% of the occupied bandwidth (OBW) and video bandwidth (VBW) shall be at least 3x RBW.

2.4.3 Equipment Under Test and Modification State

Serial No: NU: 976036000256 and CU: 977036000055 / Test Configuration A and B

2.4.4 Date of Test/Initial of test personnel who performed the test

September 28 and 29, 2020 / XYZ

2.4.5 Test Equipment Used

The major items of test equipment used for the above tests are identified in Section 3.1.

2.4.6 Environmental Conditions/ Test Location

Test performed at TÜV SÜD America Inc. Rancho Bernardo facility

Ambient Temperature	22.3 - 23.0 °C
Relative Humidity	49.8 - 57.6 %
ATM Pressure	98.7 - 98.9 kPa



2.4.7 Additional Observations

- This is a conducted test. Both 26dB bandwidth and 99% bandwidth presented.
- EUT Downlink transmits on two internal antennas and uplink transmits on two external antennas simultaneously in the same frequency range, i.e. TX MIMO mode. However, there is no much difference between two antenna ports and the measurement was performed on one antenna port as representative configuration.
- Using the occupied bandwidth measurement function in the spectrum analyzer, the 99% occupied bandwidth was measured.
- The 26dB bandwidth was measured in accordance with ANSI C63.26 clause 5.4.3 using the ndB measurement function in the spectrum analyzer.
- The transmitter shall be operated at its maximum carrier power measured under normal test conditions.
- The span of the analyzer shall be set to capture all products of the modulation process, including the emission skirts.
- The RBW is set to 1% of the OBW while the VBW is $\geq 3X$ RBW.
- The detector is peak and the trace mode is max hold.
- All low, middle and high channels were verified. Only test plots for middle channel presented in this test report as the representative configuration.

2.4.8 Test Results and Sample Test Plot

LTE Band 2 Downlink				
Bandwidth (MHz)	Channel	Frequency (MHz)	OBW (MHz)	-26dB BW (MHz)
5	625	1932.5	4.40	4.79
	900	1960.0	4.50	4.84
	1175	1987.5	4.44	4.87
10	650	1935.0	8.66	9.29
	900	1960.0	8.73	9.26
	1150	1985.0	8.78	9.42
15	675	1937.5	13.10	14.07
	900	1960.0	13.24	14.04
	1125	1982.5	13.26	14.26
20	700	1940.0	17.62	18.61
	900	1960.0	17.96	19.26
	1100	1980.0	17.72	18.84



LTE Band 2 Uplink				
Bandwidth (MHz)	Channel	Frequency (MHz)	OBW (MHz)	-26dB BW (MHz)
5	18625	1852.5	4.40	4.71
	18900	1880.0	4.41	4.70
	19175	1907.5	4.41	4.72
10	18650	1855.0	8.77	9.26
	18900	1880.0	8.76	9.29
	19150	1905.0	8.73	9.28
15	18675	1857.5	13.18	14.0
	18900	1880.0	13.25	13.99
	19125	1902.5	13.15	14.03
20	18700	1860.0	17.68	18.71
	18900	1880.0	17.73	18.70
	19100	1900.0	17.66	18.82

LTE Band 4 Downlink				
Bandwidth (MHz)	Channel	Frequency (MHz)	OBW (MHz)	-26dB BW (MHz)
5	1975	2112.5	4.44	4.89
	2175	2132.5	4.45	4.93
	2375	2152.5	4.45	4.91
10	2000	2115.0	8.78	9.43
	2175	2132.5	8.79	9.40
	2350	2150.0	8.76	9.41
15	2025	2117.5	13.25	14.42
	2175	2132.5	13.29	14.54
	2325	2147.5	13.26	14.47
20	2050	2120.0	17.85	19.14
	2175	2132.5	17.84	19.22
	2300	2145.0	18.0	19.22

LTE Band 4 Uplink				
Bandwidth (MHz)	Channel	Frequency (MHz)	OBW (MHz)	-26dB BW (MHz)
5	19975	1712.5	4.40	4.70
	20175	1732.5	4.41	4.69
	20375	1752.5	4.42	4.69
10	20000	1715.0	8.78	9.28
	20175	1732.5	8.77	9.29
	20350	1750.0	8.75	9.24
15	20025	1717.5	13.20	14.06
	20175	1732.5	13.26	14.05
	20325	1747.5	13.20	14.05
20	20050	1720.0	17.71	18.76
	20175	1732.5	17.68	18.65
	20300	1745.0	17.67	18.70



LTE Band 12 Downlink				
Bandwidth (MHz)	Channel	Frequency (MHz)	OBW (MHz)	-26dB BW (MHz)
5	5035	731.5	4.40	4.71
	5095	737.5	4.40	4.75
	5155	743.5	4.42	4.74
10	5060	734.0	8.78	9.33
	5095	737.5	8.77	9.29
	5130	741.0	8.76	9.29

LTE Band 12 Uplink				
Bandwidth (MHz)	Channel	Frequency (MHz)	OBW (MHz)	-26dB BW (MHz)
5	23035	701.5	4.42	4.74
	23095	707.5	4.40	4.72
	23155	713.5	4.42	4.72
10	23060	704.0	8.78	9.28
	23095	707.5	8.75	9.25
	23130	711.0	8.76	9.25



LTE Band 2 Downlink (5 MHz BW) / Middle Channel 1960.0 MHz / 99%OBW



12:40:36 29.09.2020

LTE Band 2 Downlink (5 MHz BW) / Middle Channel 1960.0 MHz / 26dB BW

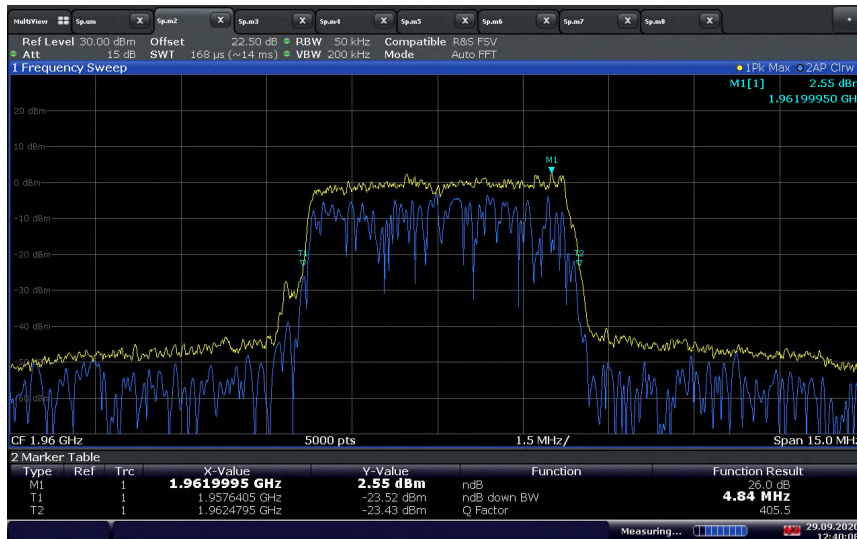

12:40:09 29.09.2020



LTE Band 2 Downlink (10 MHz BW) / Middle Channel 1960.0 MHz / 99%OBW



12:57:57 29.09.2020

LTE Band 2 Downlink (10 MHz BW) / Middle Channel 1960.0 MHz / 26dB BW



12:58:37 29.09.2020



LTE Band 2 Downlink (15 MHz BW) / Middle Channel 1960.0 MHz / 99%OBW



13:30:46 29.09.2020

LTE Band 2 Downlink (15 MHz BW) / Middle Channel 1960.0 MHz / 26dB BW



13:31:27 29.09.2020

LTE Band 2 Downlink (20 MHz BW) / Middle Channel 1960.0 MHz / 99%OBW



13:51:30 29.09.2020

LTE Band 2 Downlink (20 MHz BW) / Middle Channel 1960.0 MHz / 26dB BW

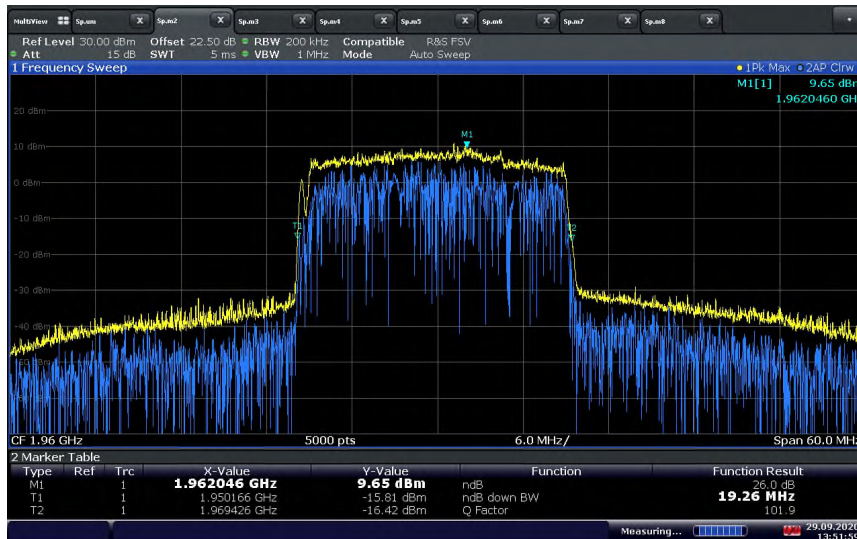

13:51:59 29.09.2020



LTE Band 2 Uplink (5 MHz BW) / Middle Channel 1880.0 MHz / 99%OBW



13:52:08 28.09.2020

LTE Band 2 Uplink (5 MHz BW) / Middle Channel 1880.0 MHz / 26dB BW

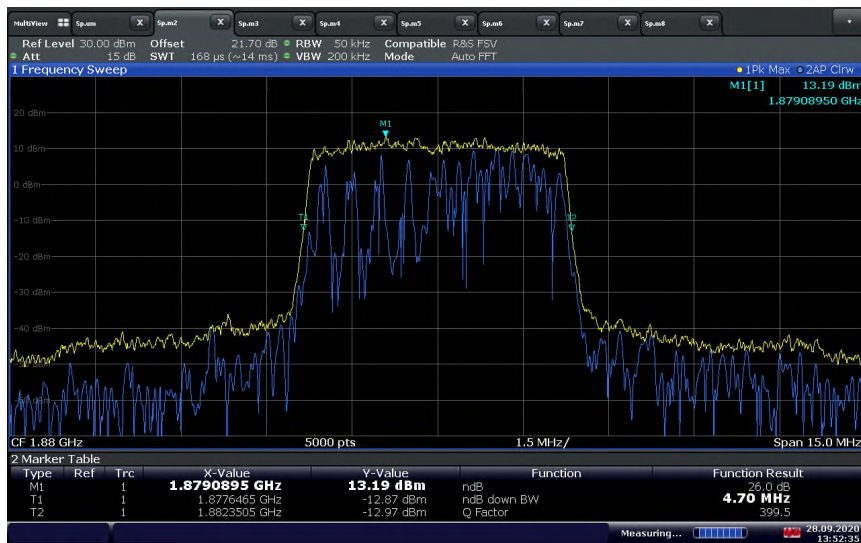

13:52:35 28.09.2020

LTE Band 2 Uplink (10 MHz BW) / Middle Channel 1880.0 MHz / 99%OBW



14:17:46 28.09.2020

LTE Band 2 Uplink (10 MHz BW) / Middle Channel 1880.0 MHz / 26dB BW



14:18:31 28.09.2020

LTE Band 2 Uplink (15 MHz BW) / Middle Channel 1880.0 MHz / 99%OBW



14:32:55 28.09.2020

LTE Band 2 Uplink (15 MHz BW) / Middle Channel 1880.0 MHz / 26dB BW



14:18:31 28.09.2020

LTE Band 2 Uplink (20 MHz BW) / Middle Channel 1880.0 MHz / 99%OBW

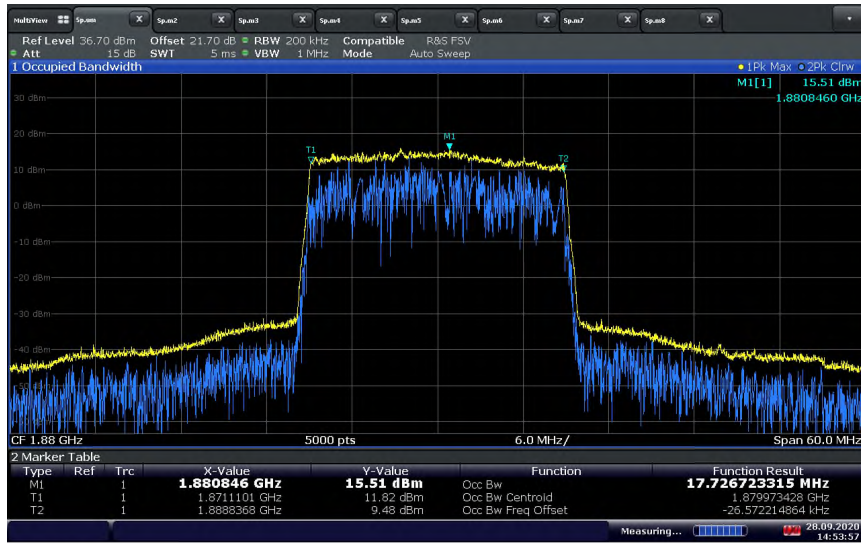

14:53:58 28.09.2020

LTE Band 2 Uplink (20 MHz BW) / Middle Channel 1880.0 MHz / 26dB BW

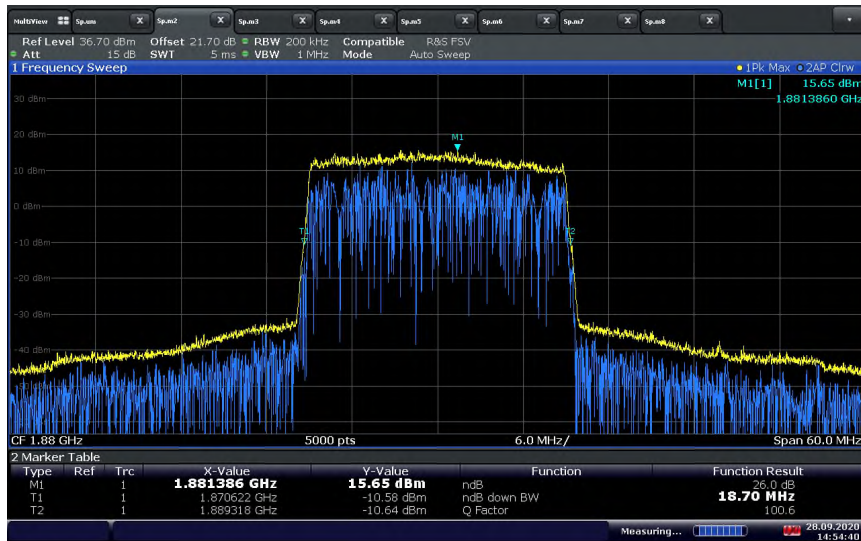

14:54:41 28.09.2020



LTE Band 4 Downlink (5 MHz BW) / Middle Channel 2132.5 MHz / 99%OBW



11:05:35 29.09.2020

LTE Band 4 Downlink (5 MHz BW) / Middle Channel 2132.5 MHz / 26dB BW



11:06:03 29.09.2020



LTE Band 4 Downlink (10 MHz BW) / Middle Channel 2132.5 MHz / 99%OBW

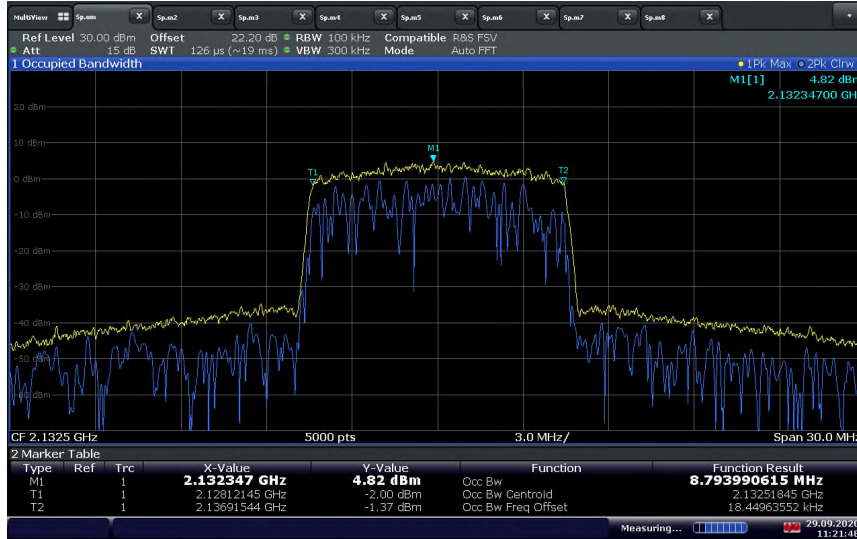

11:21:49 29.09.2020

LTE Band 4 Downlink (10 MHz BW) / Middle Channel 2132.5 MHz / 26dB BW



11:22:34 29.09.2020



LTE Band 4 Downlink (15 MHz BW) / Middle Channel 2132.5 MHz / 99%OBW



11:32:49 29.09.2020

LTE Band 4 Downlink (15 MHz BW) / Middle Channel 2132.5 MHz / 26dB BW



11:33:40 29.09.2020

LTE Band 4 Downlink (20 MHz BW) / Middle Channel 2132.5 MHz / 99%OBW

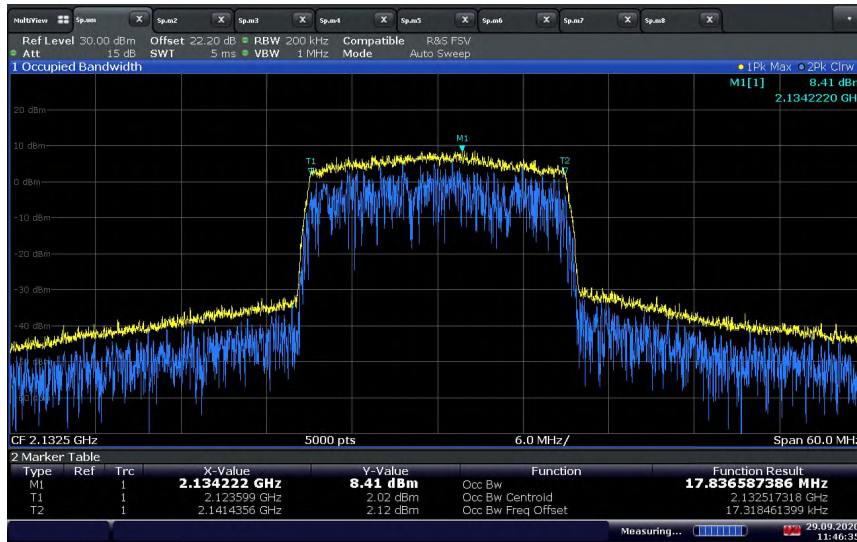

11:46:36 29.09.2020

LTE Band 4 Downlink (20 MHz BW) / Middle Channel 2132.5 MHz / 26dB BW

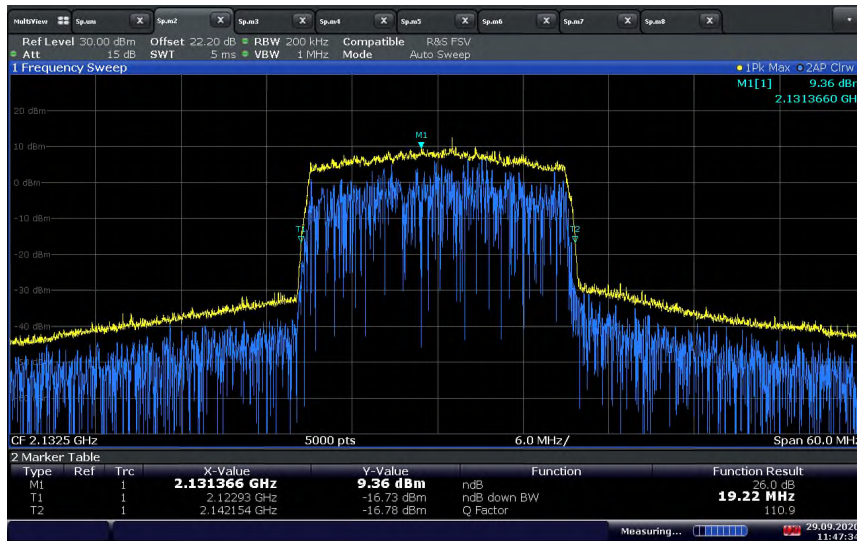

11:47:36 29.09.2020



LTE Band 4 Uplink (5 MHz BW) / Middle Channel 1732.5 MHz / 99%OBW



08:55:27 29.09.2020

LTE Band 4 Uplink (5 MHz BW) / Middle Channel 1732.5 MHz / 26dB BW

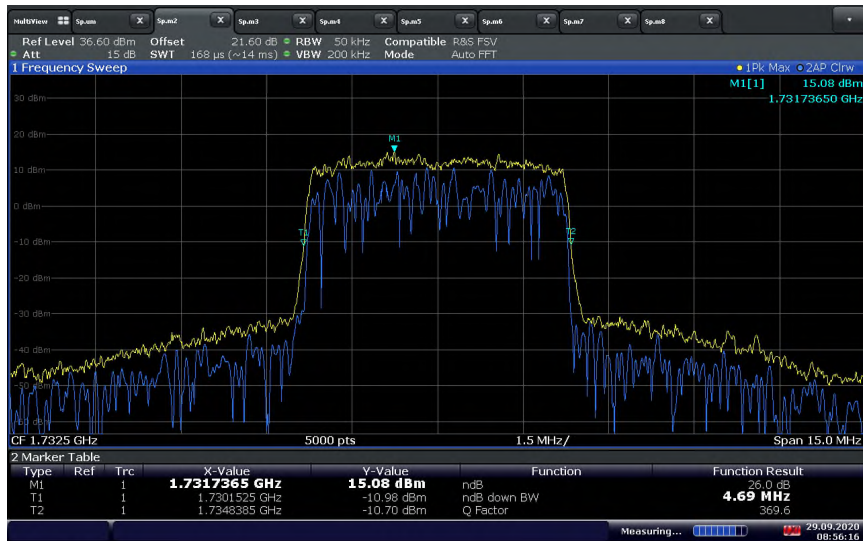

08:56:17 29.09.2020



LTE Band 4 Uplink (10 MHz BW) / Middle Channel 1732.5 MHz / 99%OBW



08:49:55 29.09.2020

LTE Band 4 Uplink (10 MHz BW) / Middle Channel 1732.5 MHz / 26dB BW



08:52:37 29.09.2020



LTE Band 4 Uplink (15 MHz BW) / Middle Channel 1732.5 MHz / 99%OBW



09:19:30 29.09.2020

LTE Band 4 Uplink (15 MHz BW) / Middle Channel 1732.5 MHz / 26dB BW



09:20:08 29.09.2020

LTE Band 4 Uplink (20 MHz BW) / Middle Channel 1732.5 MHz / 99%OBW

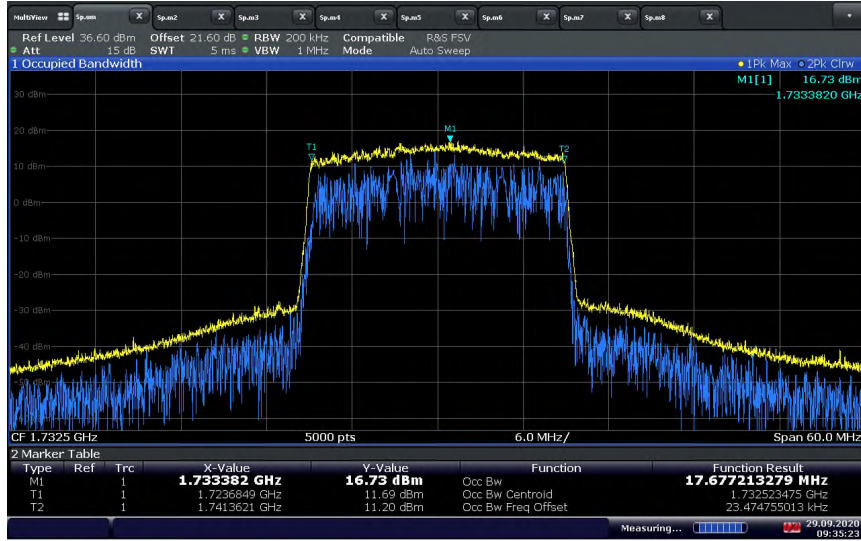

09:35:23 29.09.2020

LTE Band 4 Uplink (20 MHz BW) / Middle Channel 1732.5 MHz / 26dB BW



09:36:04 29.09.2020

LTE Band 12 Downlink (5 MHz BW) / Middle Channel 737.5 MHz / 99%OBW



14:07:54 29.09.2020

LTE Band 12 Downlink (5 MHz BW) / Middle Channel 737.5 MHz / 26dB BW



14:12:26 29.09.2020



LTE Band 12 Downlink (10 MHz BW) / Middle Channel 737.5 MHz / 99%OBW



14:24:05 29.09.2020

LTE Band 12 Downlink (10 MHz BW) / Middle Channel 737.5 MHz / 26dB BW

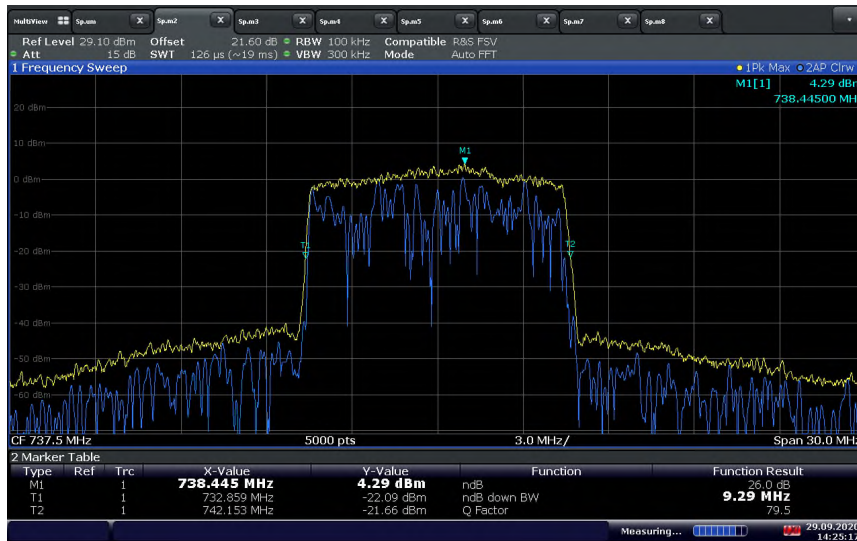

14:25:18 29.09.2020



LTE Band 12 Uplink (5 MHz BW) / Middle Channel 707.5 MHz / 99%OBW

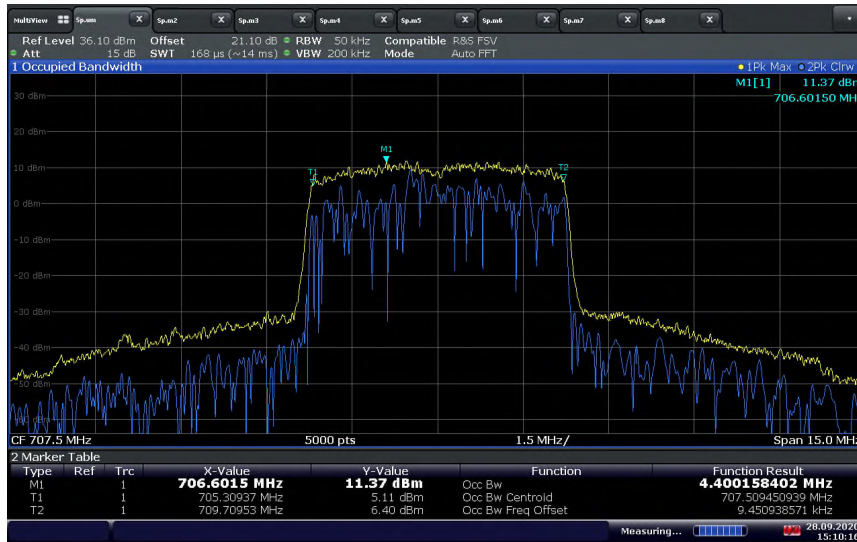

15:10:17 28.09.2020

LTE Band 12 Uplink (5 MHz BW) / Middle Channel 707.5 MHz / 26dB BW

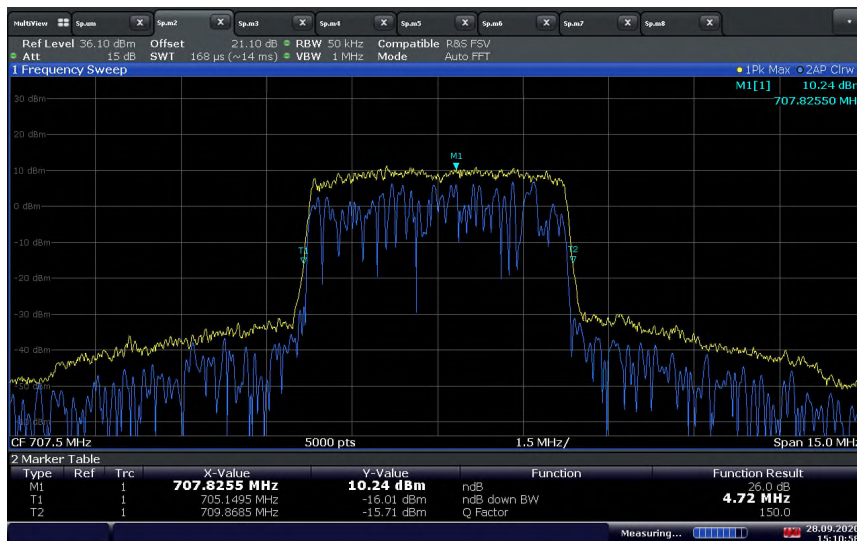

15:10:58 28.09.2020

LTE Band 12 Uplink (10 MHz BW) / Middle Channel 707.5 MHz / 99%OBW



15:24:46 28.09.2020

LTE Band 12 Uplink (10 MHz BW) / Middle Channel 707.5 MHz / 26dB BW



15:25:24 28.09.2020

2.5 PEAK-AVERAGE RATIO

2.5.1 Specification Reference

FCC 47 CFR Part 24, Clause 24.232(d)
FCC 47 CFR Part 27, Clause 27.50(d)(5)
RSS-133 issue 6, Clause 6.4
RSS-130 issue 2, Clause 4.6.1

2.5.2 Standard Applicable

The peak-to-average power ratio (PAPR) of the transmitter shall not exceed 13 dB for more than 0.1% of the time and shall use a signal corresponding to the highest PAPR during periods of continuous transmission.

2.5.3 Equipment Under Test and Modification State

Serial No: NU: 976036000256 and CU: 977036000055 / Test Configuration A and B

2.5.4 Date of Test/Initial of test personnel who performed the test

September 28 and 29, 2020 / XYZ

2.5.5 Test Equipment Used

The major items of test equipment used for the above tests are identified in Section 3.1.

2.5.6 Environmental Conditions/ Test Location

Test performed at TÜV SÜD America Inc. Rancho Bernardo facility

Ambient Temperature	22.3 - 23.0 °C
Relative Humidity	49.8 - 57.6 %
ATM Pressure	98.7 - 98.9 kPa

2.5.7 Additional Observations

- This is a conducted test.
- EUT Downlink transmits on two internal antennas and uplink transmits on two external antennas simultaneously in the same frequency range, i.e. TX MIMO mode. However, there is no much difference between two antenna ports and the measurement was performed on one antenna port as representative configuration.
- Test procedure is per FCC KDB 971168 D01 v03r01 clause 5.7, the PAPR was measured in accordance with ANSI C63.26 clause 5.2.3.4.
- Measurement was done using the Spectrum Analyzer's Complementary Cumulative Distribution Function (CCDF) measurement profile. The built-in function is used to determine the largest deviation between the average and the peak power of the EUT in a given bandwidth (crest factor or peak-to-average ratio) A CCDF curve depicts the probability of the peak signal amplitude exceeding the average power level. Most contemporary measurement instrumentation include the capability to produce CCDF curves for an input signal provided that the instrument's resolution bandwidth can be set wide enough to accommodate the entire input signal bandwidth.
- RBW was set to maximum the SA can support.
- There are no measured PAR levels greater than 13dB.

- Low, Middle and High channels for all supporting bandwidths were verified.
- Only test plots for middle channel were presented as the representative configuration.

2.5.8 Test Results

LTE Band 2 Downlink			
Bandwidth (MHz)	Channels	Frequency (MHz)	PAR (dB)
5	625	1932.5	7.60
	900	1960.0	9.36
	1175	1987.5	8.01
10	650	1935.0	8.29
	900	1960.0	8.58
	1150	1985.0	8.73
15	675	1937.5	9.06
	900	1960.0	9.23
	1125	1982.5	9.15
20	700	1940.0	7.69
	900	1960.0	7.56
	1100	1980.0	7.34

LTE Band 2 Uplink			
Bandwidth (MHz)	Channels	Frequency (MHz)	PAR (dB)
5	18625	1852.5	6.71
	18900	1880.0	7.04
	19175	1907.5	6.52
10	18650	1855.0	6.52
	18900	1880.0	6.45
	19150	1905.0	6.59
15	18675	1857.5	9.47
	18900	1880.0	9.80
	19125	1902.5	9.65
20	18700	1860.0	6.99
	18900	1880.0	7.13
	19100	1900.0	7.28



LTE Band 4 Downlink			
Bandwidth (MHz)	Channels	Frequency (MHz)	PAR (dB)
5	1975	2112.5	8.34
	2175	2132.5	8.59
	2375	2152.5	9.27
10	2000	2115.0	8.19
	2175	2132.5	9.01
	2350	2150.0	9.24
15	2025	2117.5	9.63
	2175	2132.5	10.16
	2325	2147.5	9.66
20	2050	2120.0	7.77
	2175	2132.5	7.92
	2300	2145.0	8.42

LTE Band 4 Uplink			
Bandwidth (MHz)	Channels	Frequency (MHz)	PAR (dB)
5	19975	1712.5	6.20
	20175	1732.5	6.32
	20375	1752.5	6.40
10	20000	1715.0	6.39
	20175	1732.5	6.46
	20350	1750.0	6.47
15	20025	1717.5	8.55
	20175	1732.5	8.70
	20325	1747.5	8.53
20	20050	1720.0	6.58
	20175	1732.5	6.72
	20300	1745.0	6.41



LTE Band 12 Downlink			
Bandwidth (MHz)	Channels	Frequency (MHz)	PAR (dB)
5	5035	731.5	6.96
	5095	737.5	6.98
	5155	743.5	7.13
10	5060	734.0	7.08
	5095	737.5	7.12
	5130	741.0	6.79

LTE Band 12 Uplink			
Bandwidth (MHz)	Channels	Frequency (MHz)	PAR (dB)
5	23035	701.5	6.69
	23095	707.5	6.66
	23155	713.5	6.59
10	23060	704.0	6.39
	23095	707.5	6.38
	23130	711.0	6.41

2.5.9 Sample Test Plot

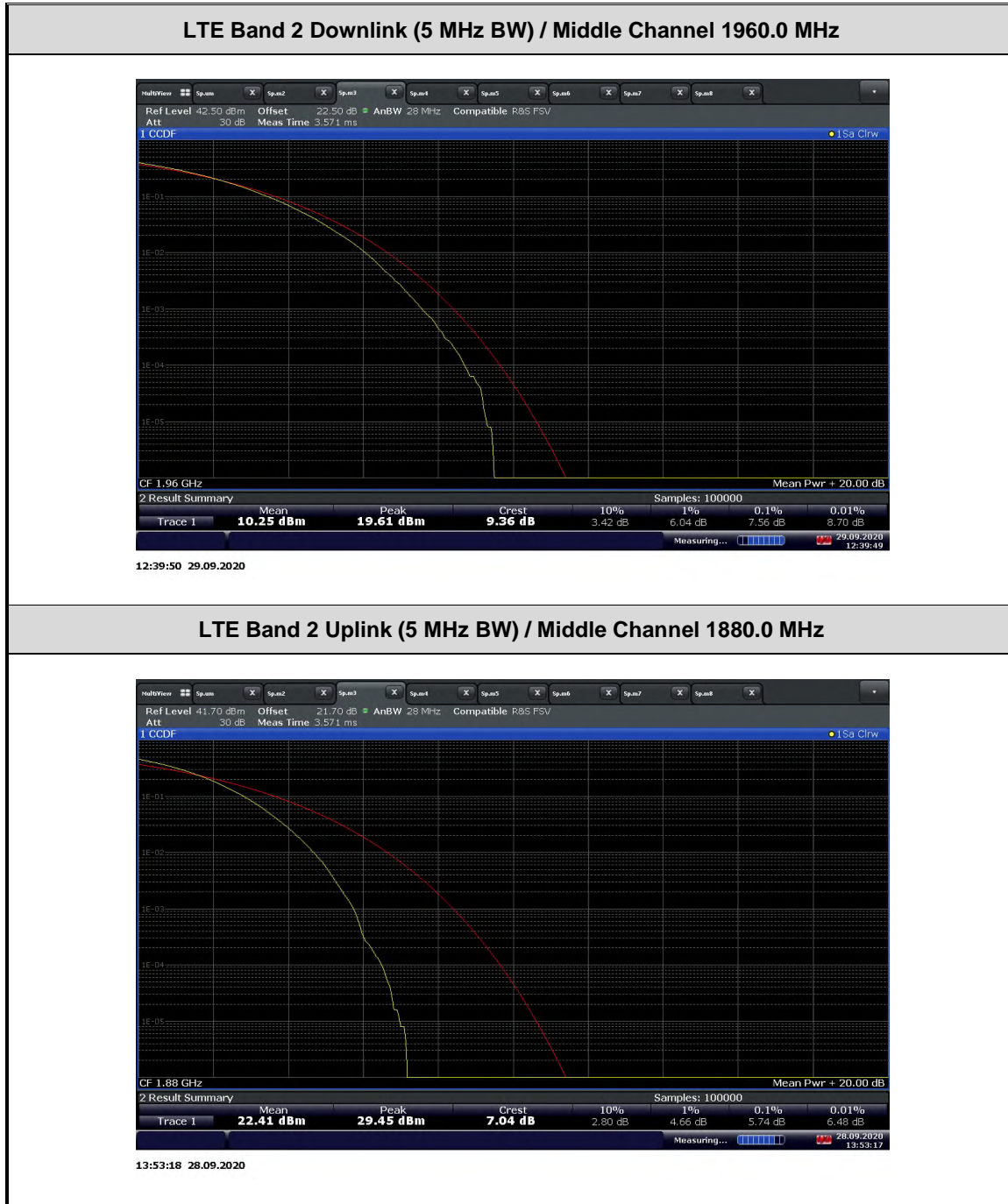

LTE Band 4 Downlink (5 MHz BW) / Middle Channel 2132.5 MHz



11:06:31 29.09.2020

LTE Band 4 Uplink (5 MHz BW) / Middle Channel 1732.5 MHz

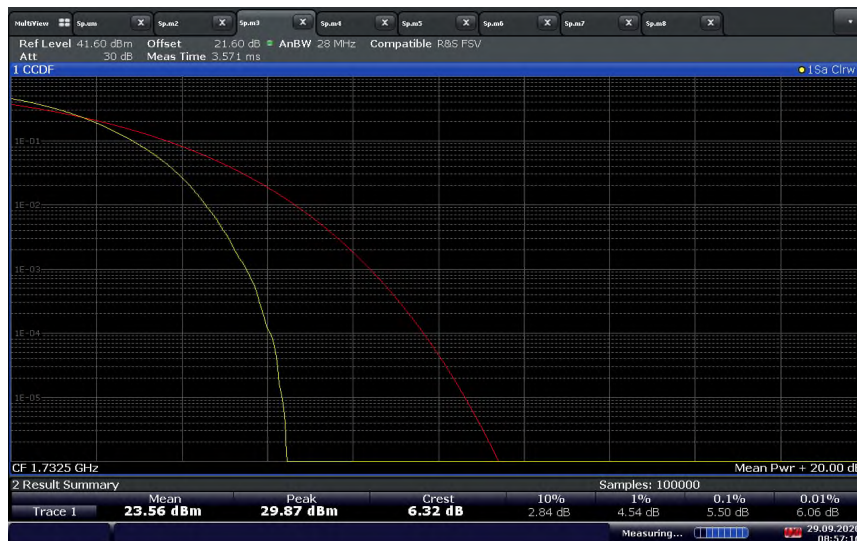

08:57:17 29.09.2020

LTE Band 12 Downlink (5 MHz BW) / Middle Channel 737.5 MHz

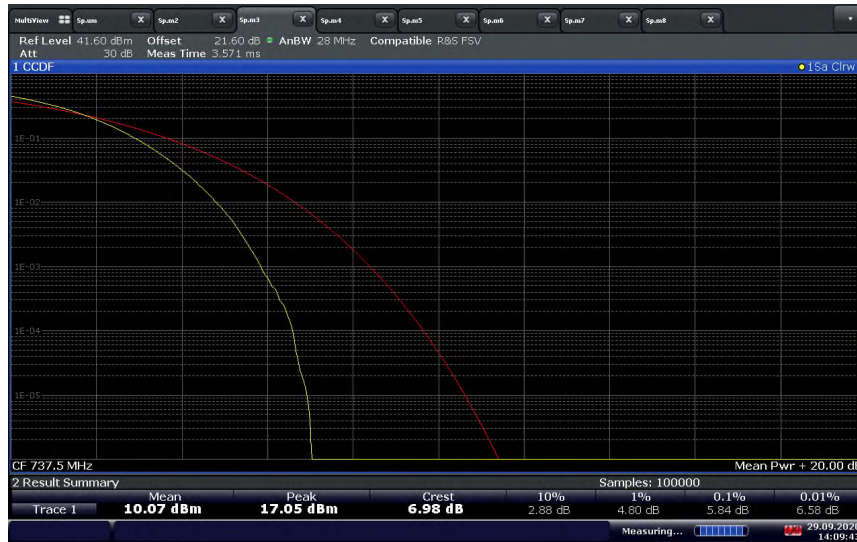

14:09:44 29.09.2020

LTE Band 12 Uplink (5 MHz BW) / Middle Channel 707.5 MHz



15:12:46 28.09.2020



2.6 BAND EDGE

2.6.1 Specification Reference

FCC 47 CFR Part 2, Clause 2.1051
FCC 47 CFR Part 24, Clause 24.238(a)(b)
FCC 47 CFR Part 27, Clause 27.53(h)(1)(3)
FCC 47 CFR Part 27, Clause 27.53(g)
RSS-133, Clause 6.5
RSS-130, Clause 4.7

2.6.2 Standard Applicable

FCC 47 CFR Part 27, Clause 24.238:

(a) Out of band emissions. The power of any emission outside of the authorized operating frequency ranges must be attenuated below the transmitting power (P) by a factor of at least $43 + 10\log(P)$ dB.

FCC 47 CFR Part 27, Clause 27.53:

(h) AWS emission limits – (1) General protection levels. Except as otherwise specified below, for operations in the 1695-1710 MHz, 1710-1755 MHz, 1755-1780 MHz, 1915-1920 MHz, 1995-2000 MHz, 2000-2020 MHz, 2110-2155 MHz, 2155-2180 MHz, and 2180-2200 MHz bands, the power of any emission outside a licensee's frequency block shall be attenuated below the transmitter power (P) in watts by at least $43 + 10 \log_{10}(P)$ dB.

(g) For operations in the 600 MHz band and the 698–746 MHz band, the power of any emission outside a licensee's frequency band(s) of operation shall be attenuated below the transmitter power (P) within the licensed band(s) of operation, measured in watts, by at least $43 + 10 \log(P)$ dB. Compliance with this provision is based on the use of measurement instrumentation employing a resolution bandwidth of 100 kilohertz or greater. However, in the 100 kilohertz bands immediately outside and adjacent to a licensee's frequency block, a resolution bandwidth of at least 30 kHz may be employed.

RSS-133, Clause 6.5:

Equipment shall comply with the limits in (i) and (ii) below.

i. In the 1.0 MHz bands immediately outside and adjacent to the equipment's operating frequency block, the emission power per any 1% of the emission bandwidth shall be attenuated (in dB) below the transmitter output power P (dBW) by at least $43 + 10 \log_{10}p(\text{watts})$.

ii. After the first 1.0 MHz, the emission power in any 1 MHz bandwidth shall be attenuated (in dB) below the transmitter output power P (dBW) by at least $43 + 10 \log_{10}p(\text{watts})$. If the measurement is performed using 1% of the emission bandwidth, power integration over 1.0 MHz is required.

RSS-130:

4.7.1 General unwanted emissions limits

The unwanted emissions in any 100 kHz bandwidth on any frequency outside the low frequency edge and the high frequency edge of each frequency block range(s), shall be attenuated below the transmitter power, P (dBW), by at least $43 + 10 \log_{10} p(\text{watts})$, dB. However, in the 100 kHz band immediately outside of the equipment's frequency block range, a resolution bandwidth of 30 kHz may be employed.



2.6.3 Equipment Under Test and Modification State

Serial No: NU: 976036000256 and CU: 977036000055 / Test Configuration A and B

2.6.4 Date of Test/Initial of test personnel who performed the test

October 02 and 03, 2020 / XYZ

2.6.5 Test Equipment Used

The major items of test equipment used for the above tests are identified in Section 3.1.

2.6.6 Environmental Conditions/ Test Location

Test performed at TÜV SÜD America Inc. Rancho Bernardo facility

Ambient Temperature	23.5 - 24.5 °C
Relative Humidity	30.7 - 33.8 %
ATM Pressure	98.6 - 98.7 kPa

2.6.7 Additional Observations

- This is a conducted test.
- Test guidance is per Section 6.1 of KDB971168 (D01 Power Meas License Digital Systems v03r01).
- The path loss was measured and entered as a level offset.
- For LTE Band 12, RBW was set to 30 kHz and the limit for emissions 100 kHz outside of the low frequency edge and the high frequency edge of each frequency block range(s), was set to:

$$\text{Limit} = -13\text{dBm} + 10\lg(30/100) = -18.23 \text{ dBm}$$
- For LTE Band 2 and 4, RBW was set to 50 kHz, limit for emissions 1MHz adjacent to the low frequency edge and the high frequency edge of each frequency block range(s), was set to:

$$\text{Limit} = -13\text{dBm} + 10(\text{RBW}_{\text{used}}/1\% \text{ OBW})$$

limit for emissions 1MHz outside of the low frequency edge and the high frequency edge of each frequency block range(s), was set to:

$$\text{Limit} = -13\text{dBm} + 10(\text{RBW}_{\text{used}}/1\text{MHz})$$
- EUT Downlink transmits on two internal antennas and uplink transmits on two external antennas simultaneously in the same frequency range, i.e. TX MIMO mode. However, there is no much difference between two antenna ports and the measurement was performed on one antenna port as representative configuration. The limit should be adjusted with a correction of -3 dB [10Log(2)] by using Measure and Add 10Log(N) dB technique according to FCC KDB 662911 D01 Multiple Transmitter Output accounting for simultaneous transmission from two internal or external antenna ports.

2.6.8 Test Results

LTE Band 2 Downlink 5MHz Bandwidth Low Channel Band Edge



09:32:13 03.10.2020

The limit should be adjusted with a correction of -3 dB $[10\text{Log}(2)]$ accounting for MIMO transmission on both internal antennas

LTE Band 2 Downlink 5MHz Bandwidth High Channel Band Edge

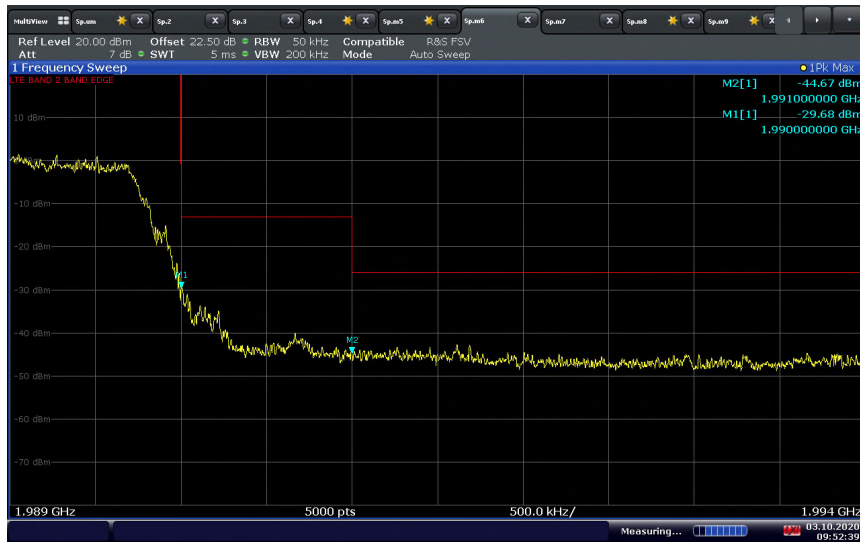

09:52:40 03.10.2020

The limit should be adjusted with a correction of -3 dB $[10\text{Log}(2)]$ accounting for MIMO transmission on both internal antennas

LTE Band 2 Downlink 10MHz Bandwidth Low Channel Band Edge

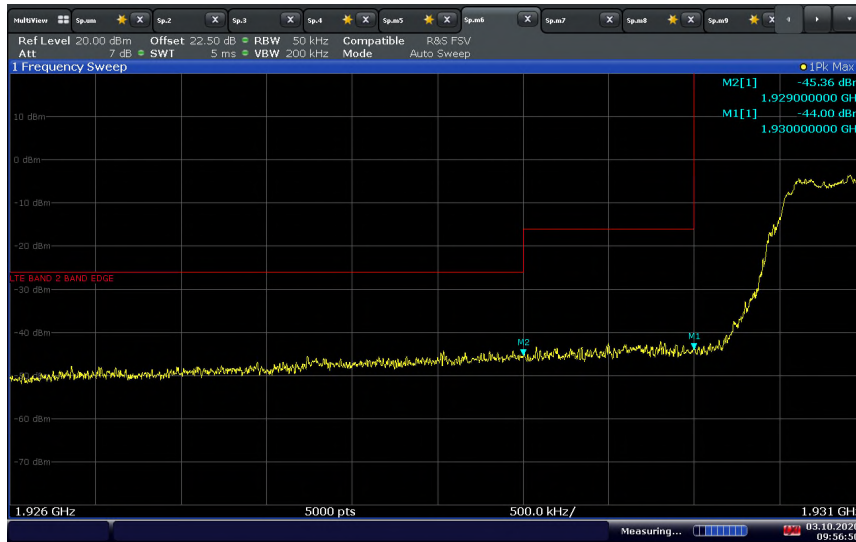

09:56:50 03.10.2020

The limit should be adjusted with a correction of -3 dB [10Log(2)]
accounting for MIMO transmission on both internal antennas

LTE Band 2 Downlink 10MHz Bandwidth High Channel Band Edge

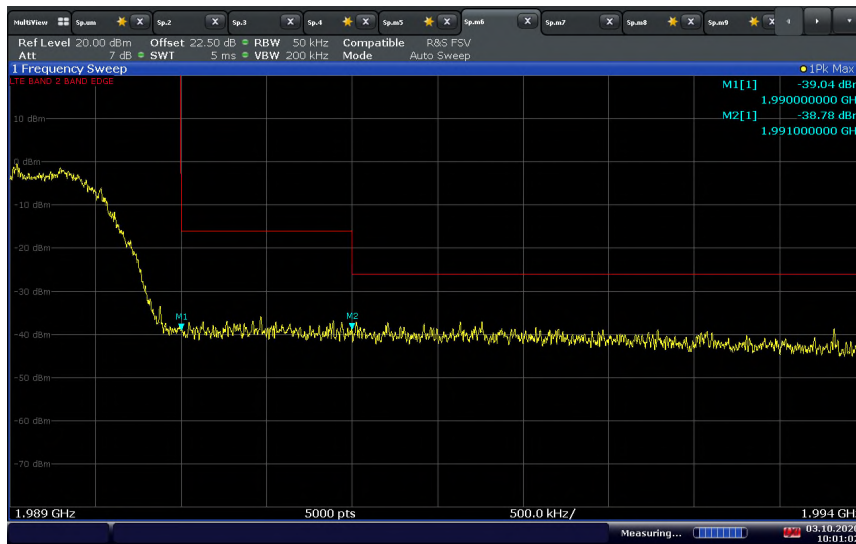

10:01:03 03.10.2020

The limit should be adjusted with a correction of -3 dB [10Log(2)]
accounting for MIMO transmission on both internal antennas

LTE Band 2 Downlink 15MHz Bandwidth Low Channel Band Edge

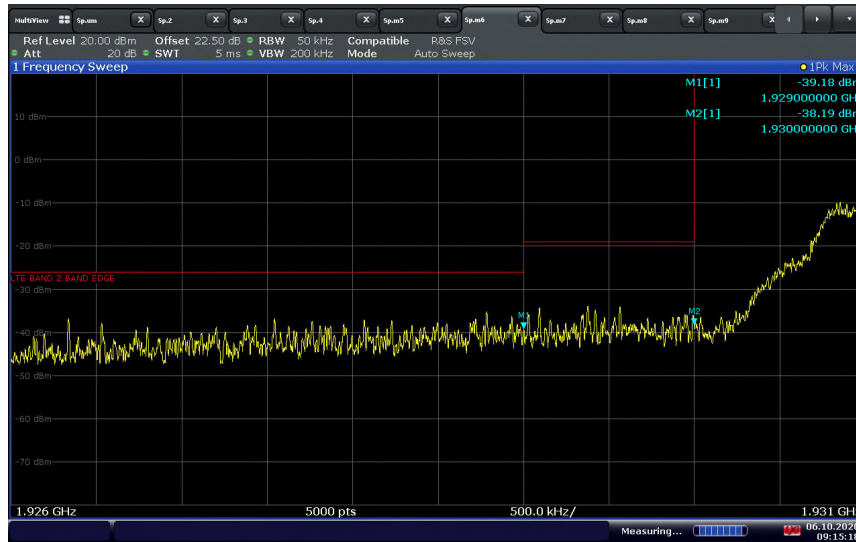

09:15:19 06.10.2020

The limit should be adjusted with a correction of -3 dB $[10\log(2)]$ accounting for MIMO transmission on both internal antennas

LTE Band 2 Downlink 15MHz Bandwidth High Channel Band Edge

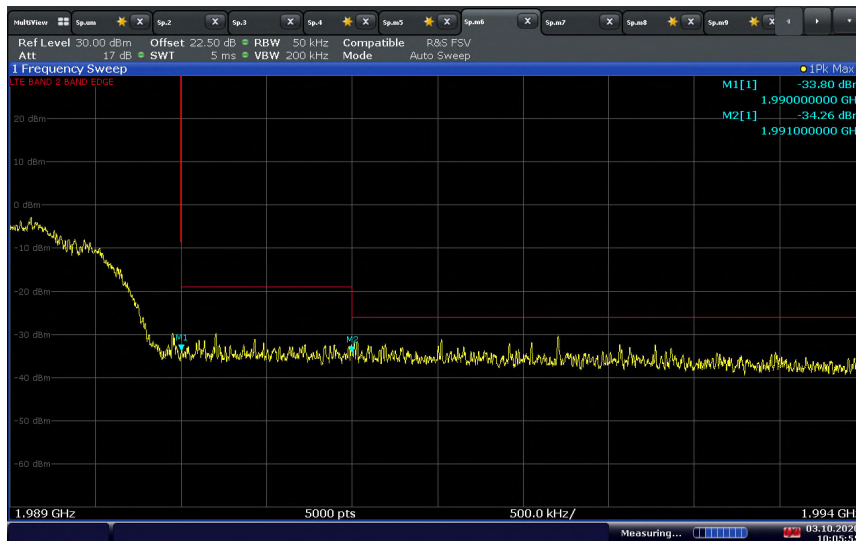

10:05:56 03.10.2020

The limit should be adjusted with a correction of -3 dB $[10\log(2)]$ accounting for MIMO transmission on both internal antennas

LTE Band 2 Downlink 20MHz Bandwidth Low Channel Band Edge

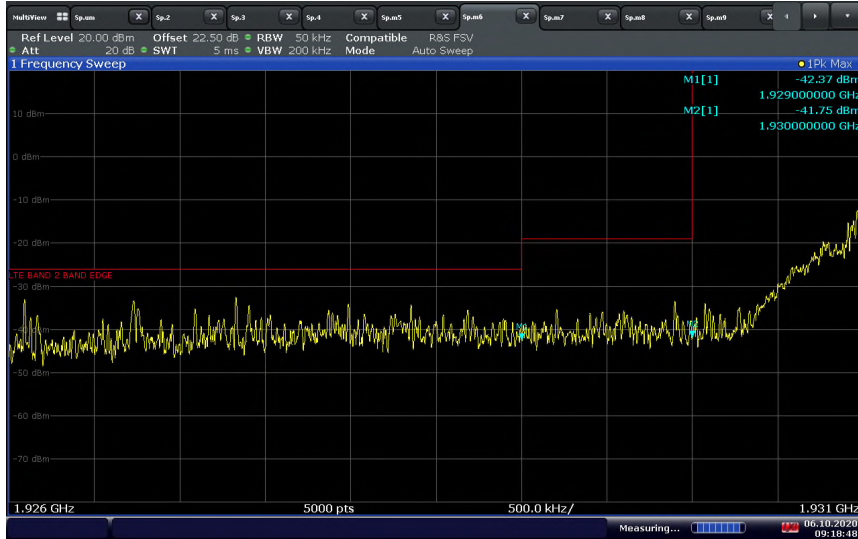

The limit should be adjusted with a correction of -3 dB $[10\text{Log}(2)]$ accounting for MIMO transmission on both internal antennas

LTE Band 2 Downlink 20MHz Bandwidth High Channel Band Edge

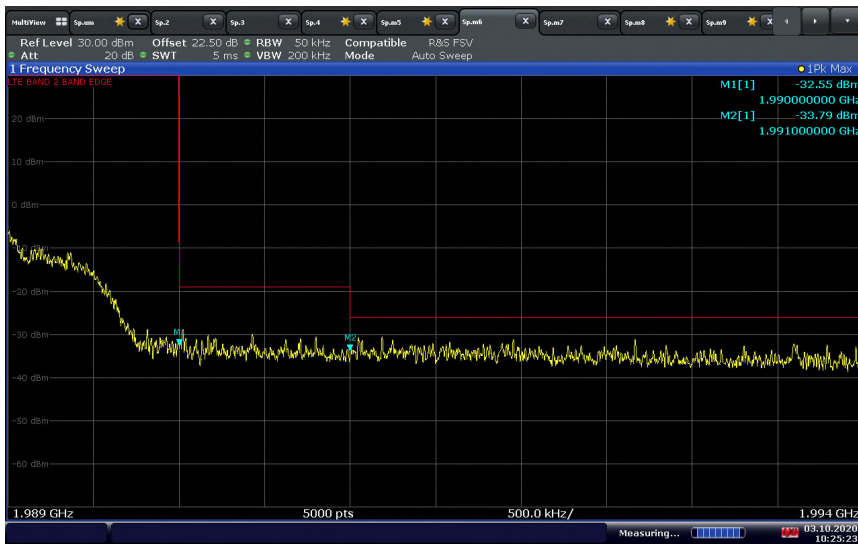

The limit should be adjusted with a correction of -3 dB $[10\text{Log}(2)]$ accounting for MIMO transmission on both internal antennas

LTE Band 2 Uplink 5MHz Bandwidth Low Channel Band Edge

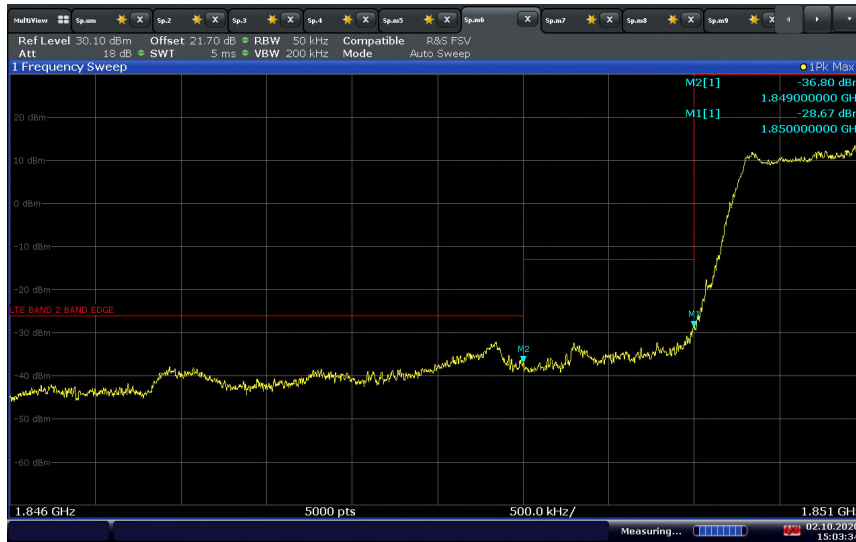

The limit should be adjusted with a correction of -3 dB $[10\log(2)]$ accounting for MIMO transmission on both internal antennas

LTE Band 2 Uplink 5MHz Bandwidth High Channel Band Edge

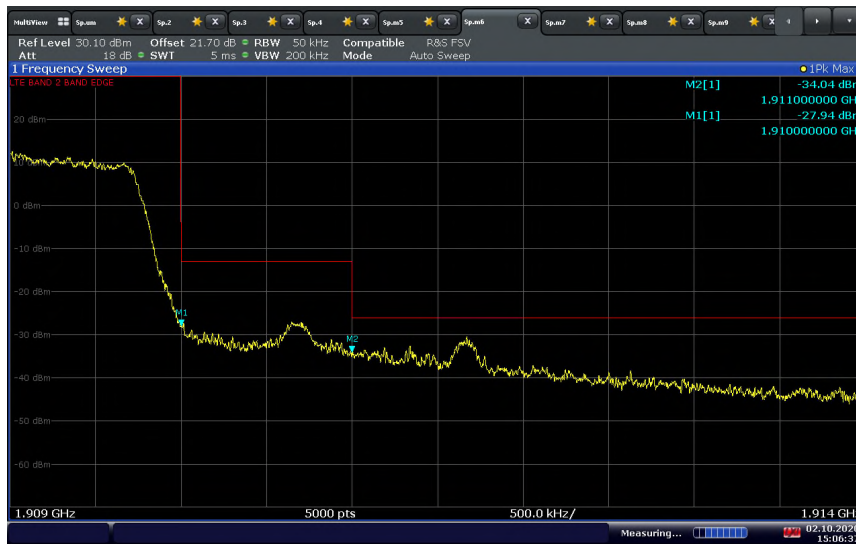

The limit should be adjusted with a correction of -3 dB $[10\log(2)]$ accounting for MIMO transmission on both internal antennas

LTE Band 2 Uplink 10MHz Bandwidth Low Channel Band Edge

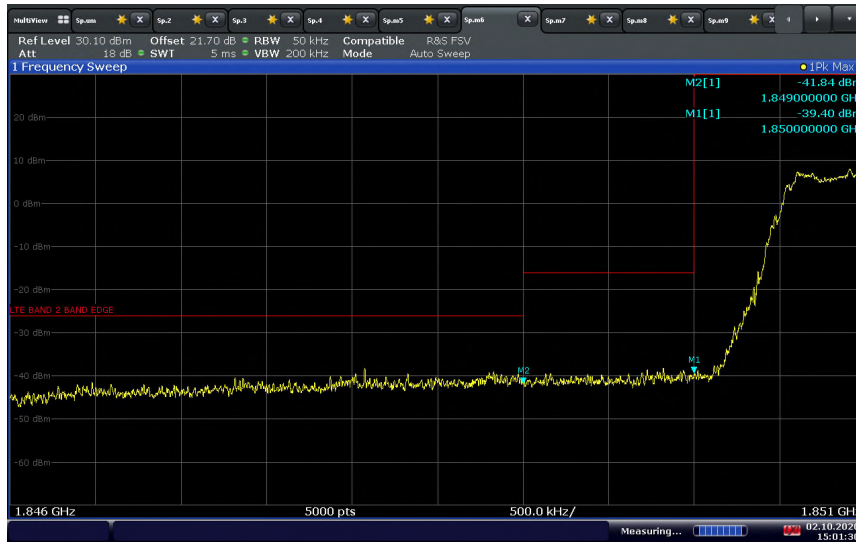

The limit should be adjusted with a correction of -3 dB $[10\text{Log}(2)]$ accounting for MIMO transmission on both internal antennas

LTE Band 2 Uplink 10MHz Bandwidth High Channel Band Edge

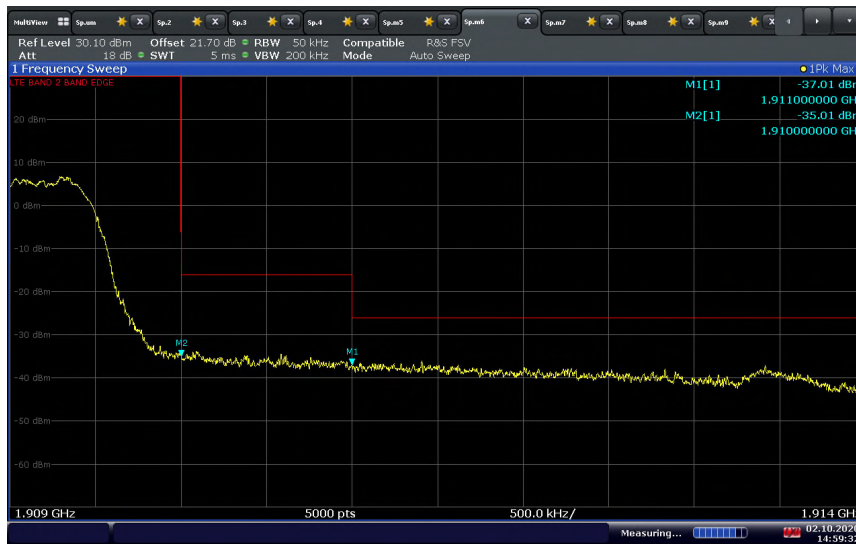

The limit should be adjusted with a correction of -3 dB $[10\text{Log}(2)]$ accounting for MIMO transmission on both internal antennas

LTE Band 2 Uplink 15MHz Bandwidth Low Channel Band Edge

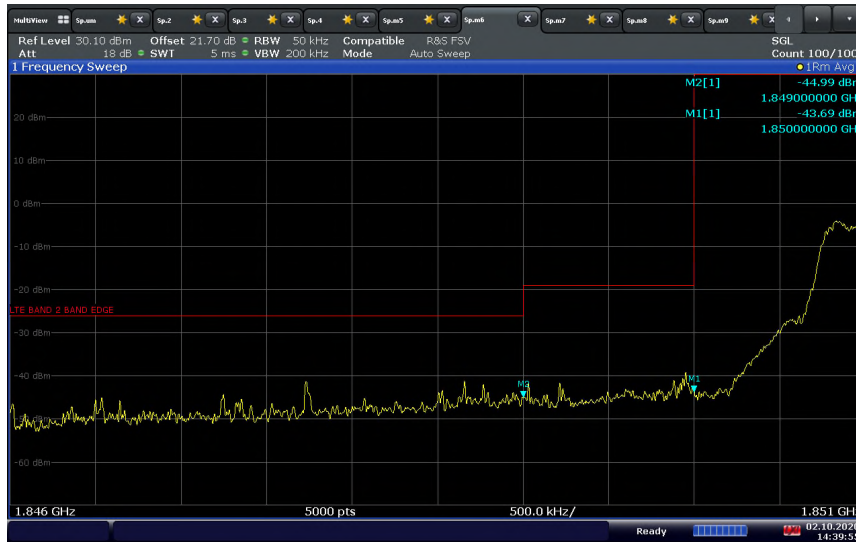

14:39:55 02.10.2020

The limit should be adjusted with a correction of -3 dB [10Log(2)] accounting for MIMO transmission on both internal antennas

LTE Band 2 Uplink 15MHz Bandwidth High Channel Band Edge

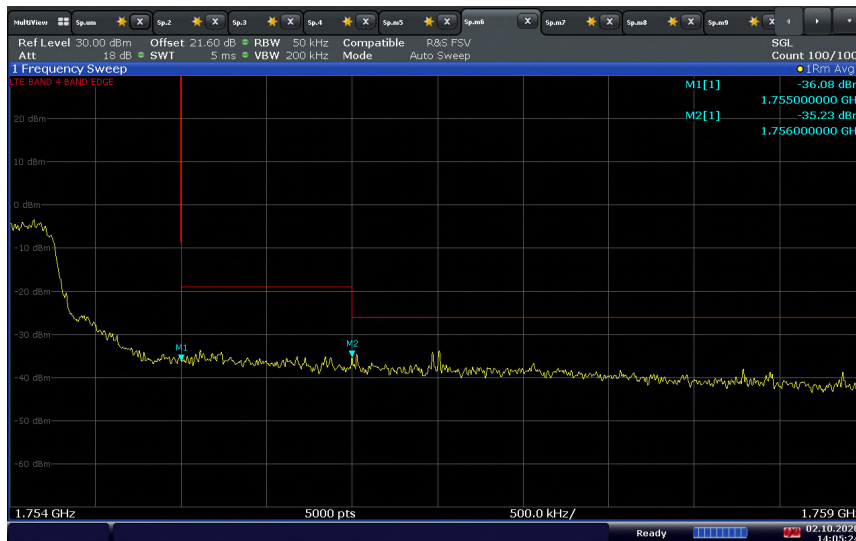

14:05:25 02.10.2020

The limit should be adjusted with a correction of -3 dB [10Log(2)] accounting for MIMO transmission on both internal antennas

LTE Band 2 Uplink 20MHz Bandwidth Low Channel Band Edge

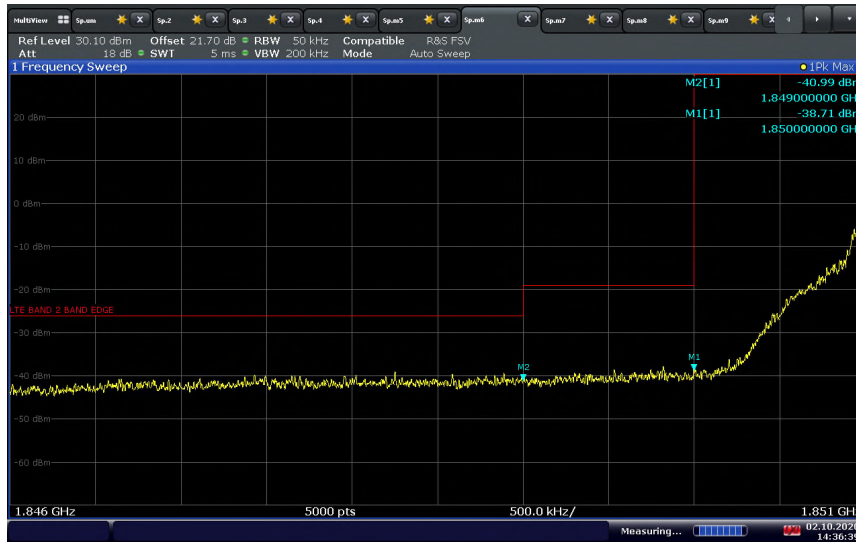

14:36:40 02.10.2020

The limit should be adjusted with a correction of -3 dB $[10\log(2)]$ accounting for MIMO transmission on both internal antennas

LTE Band 2 Uplink 20MHz Bandwidth High Channel Band Edge

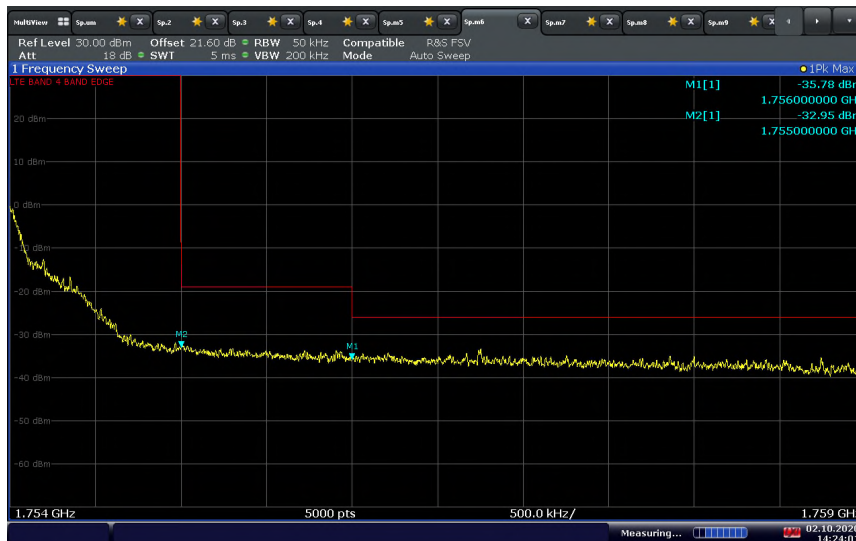

14:24:01 02.10.2020

The limit should be adjusted with a correction of -3 dB $[10\log(2)]$ accounting for MIMO transmission on both internal antennas