

QUATRA 4000c Installation and User Guide

M/N: I44-1M34NCU Industrial Booster



Table of Contents

01. Introduction to QUATRA 4000c
02. Regulatory // Model Number: Cel-Fi QUATRA 4000c
03. System Overview
04. Hardware Components
05. The WAVE Portal
06. Installation
07. LEDs
08. Diagnostics and Testing
09. Antenna Kitting
10. Advanced Information - Antennas and QUATRA 4000c
11. Specifications
12. Trademarks
13. Warranty and Limitation of Liability
14. Compliance
15. Glossary
16. Troubleshooting

About This Guide

There are a variety of Cel-Fi QUATRA product variants available, supporting a variety of band configurations, for multiple regions. This manual is applicable to the Cel-Fi QUATRA 4000c M/N: I44-1M34NCU ONLY, and does not apply to any other QUATRA variants.

Safety Precautions

- Use Cel-Fi QUATRA 4000c indoors. It should not be used outdoors.
- These products are designed to be used with the internal power supply unit that shipped with the Network Unit. When installing the equipment, all the requirements of the manufacturer and the referenced standards must be met.
- There are no user serviceable parts inside.

Caution: Changes or modifications to this product not expressly approved by Nextivity may void your right to operate the equipment.

01. Introduction to QUATRA 4000c

Understanding Cellular Coverage

Spotty cellular coverage, poor voice quality, dropped calls, and dead zones continue to plague occupants in buildings of all shapes and sizes. Nextivity's Cel-Fi QUATRA solves that problem. It is an affordable, all-digital solution, providing uniform, high-quality cellular signals throughout a building. Cel-Fi QUATRA is scalable to fit buildings of all sizes and is carrier approved and guaranteed network safe.

Unlike traditional analog boosters and passive DAS technology, QUATRA delivers a cellular signal that is up to 1000x stronger, utilizing CAT 5e (or better) cabling for the connection between the head end and each remote. The remotes are powered via Power over Ethernet (PoE), delivering an un-attenuated signal throughout the building. Cel-Fi QUATRA can be installed in just days (compared to months typical of other solutions), and at a price point that meets the middleprize budget.

The QUATRA Solution

While cellular networks are outside, the majority of calls take place inside. A recent study showed 80% of business users inside complain of poor coverage or dropped calls. Modern building materials, while improving energy efficiency, will block or inhibit cellular service from the outside network. To exacerbate the issue,

cellular coverage is increasingly critical. In fact, cellular coverage can be considered a safety or even regulatory requirement, depending on the region. Building owners need a flexible, high-quality solution. Installers and Value-Added Resellers need a product that can serve the majority of building types and not take months to deploy.

- Nextivity created a new Cel-Fi solution category that combines its core technology with the architecture of an Active DAS – to deliver an Active DAS Hybrid – carrier-grade but built for Installers.
- Integrators and Carriers have partnered with Nextivity to deliver a smart solution designed for middleprise buildings - Cel-Fi QUATRA solutions.
- Nextivity provides the QUATRA BOM Estimator to help installers select the appropriate equipment in the right quantity, to eliminate the heavy cost/time of the (pre) planning effort.
- Cel-Fi's all-digital, scalable, PoE Category cable-based solution makes it ideal for Single or Multi-Carrier environments.

Speed of Installation, higher quality in-building cellular solutions, and cost savings – are some of the reasons building owners, facility managers, and IT professionals are making the smart investment in Cel-Fi QUATRA solutions.

Comment About FCC Certification

QUATRA 4000c Model Number I44-1M34NCU supports Part 20 and Part 90 cellular bands. All Part 20 cellular bands are enabled by default, and all part 90 cellular bands are Disabled by default and must be enabled by the installer on a per-band basis once the appropriate band retransmission agreement has been acquired from the carrier. The system is also capable of relaying Band 48 on Port D, which is disabled/locked by default and may be remotely unlocked by Nextivity:

- **Cel-Fi QUATRA 4000c Model Number I44-1M34NCU**
 - This QUATRA 4000c is FCC Part 20 certified for the following bands: 2, 4, 5, 12, 13 and 25
 - This QUATRA 4000c is FCC Part 90 certified for the following bands 30, and 71*
 - This QUATRA 4000c is FCC Part 96 certified for band 48 (CBRS)

* *Band 71 pending FCC Part 20 approval*

A Solution Anyone Can Confidently Deploy

Cel-Fi QUATRA is designed to improve indoor signal coverage without any risk of interference on the mobile network. Cel-Fi QUATRA provides a sophisticated network-safe solution that has been rigorously tested globally, through multiple generations, engineered to deliver multiple levels of network protection:

- Uplink power control to prevent desensitizing the network
- Echo-cancellation and feedback control to prevent oscillation of the system
- Uplink muting, when handsets (UE) are not detected
- Signal qualification (channels are individually qualified, so noise or very poor signals won't be amplified and degrade the network)
- The Cel-Fi WAVE Platform cloud-based portal enables an operator to monitor equipment and network KPI's, such as channel configurations, RSRP, RSCP, SINR, and system gains, providing control and optimization insight.

02. Regulatory // Model Number: Cel-Fi QUATRA 4000c M/N: I44-1M34NCU [L] [SEP]

FCC Part 90/96 Certified

The QUATRA 4000c is FCC Part 90 and 96 certified for the following bands.

AT&T	12 & 5	12 & 25	12 & 4	12 & 2	30 & 5	30 & 25	30 & 4	30 & 2
T-Mobile	25 & 4	25 & 12	4 & 12	4 & 71	25 & 71	2 & 4	2 & 12	2 & 71
Verizon	13 & 25	13 & 4	13 & 2					
CBRS	48**							

* *The above is subject to change with FCC regulatory changes*

** *CBRS Class A*

03. System Overview

How Does It Work?

Cel-Fi QUATRA 4000c is a powerful cellular signal distribution solution. Cel-Fi QUATRA 4000c is fundamentally comprised of a Network Unit (NU) and up to six (6) Coverage Units (per NU). The Network Unit takes the donor input from up to four (4) carrier donor signal sources. The signal source can be off-air (over-the-air (OTA)) from the macro network or delivered via a small cell or PVT (Private CBRS network).

The NU receives and individually processes channels from each carrier, allowing a higher gain for weaker channels (up to 100 dB). The channels are digitized and sent over a pair of Ethernet cables to each CU for retransmission through one or more service antennas.

The system may also be used with one QUATRA 4000 FIBER HUB, which functions much like an NU with up to six (6) additional CUs. The HUB is connected to the NU with up to 2km of optical fiber cable and SFP+ Modules (sold separately), and it uses donor signals from the connected NU.

Architecture Overview

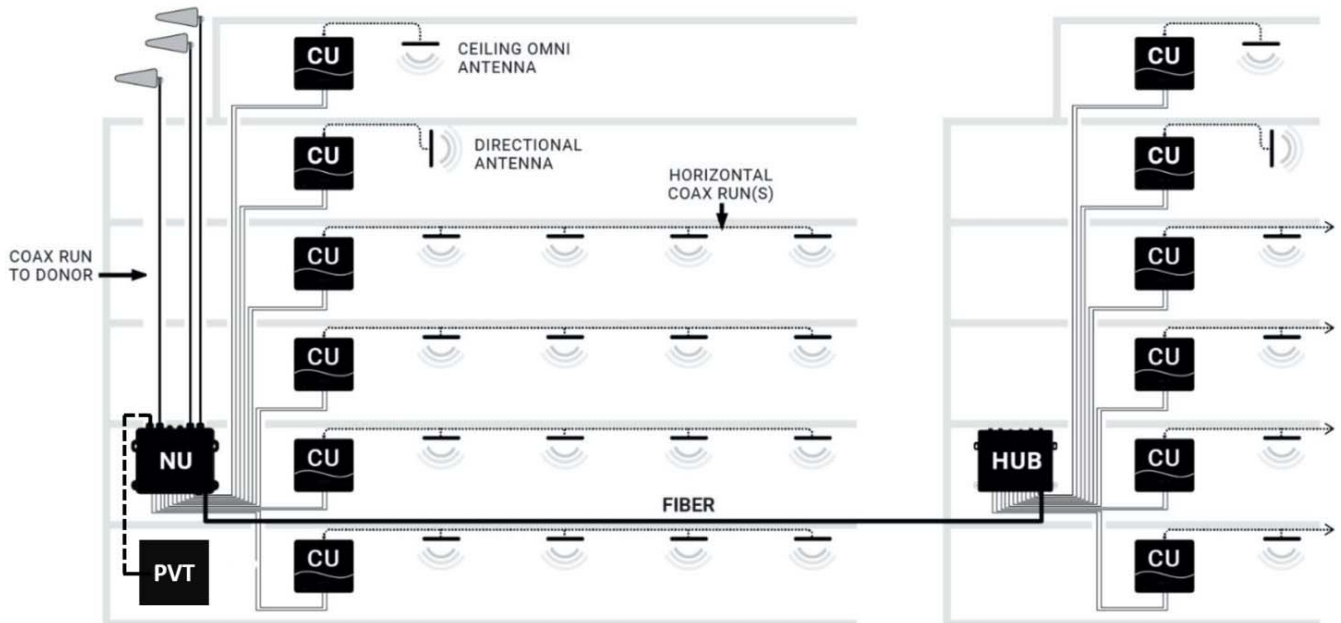
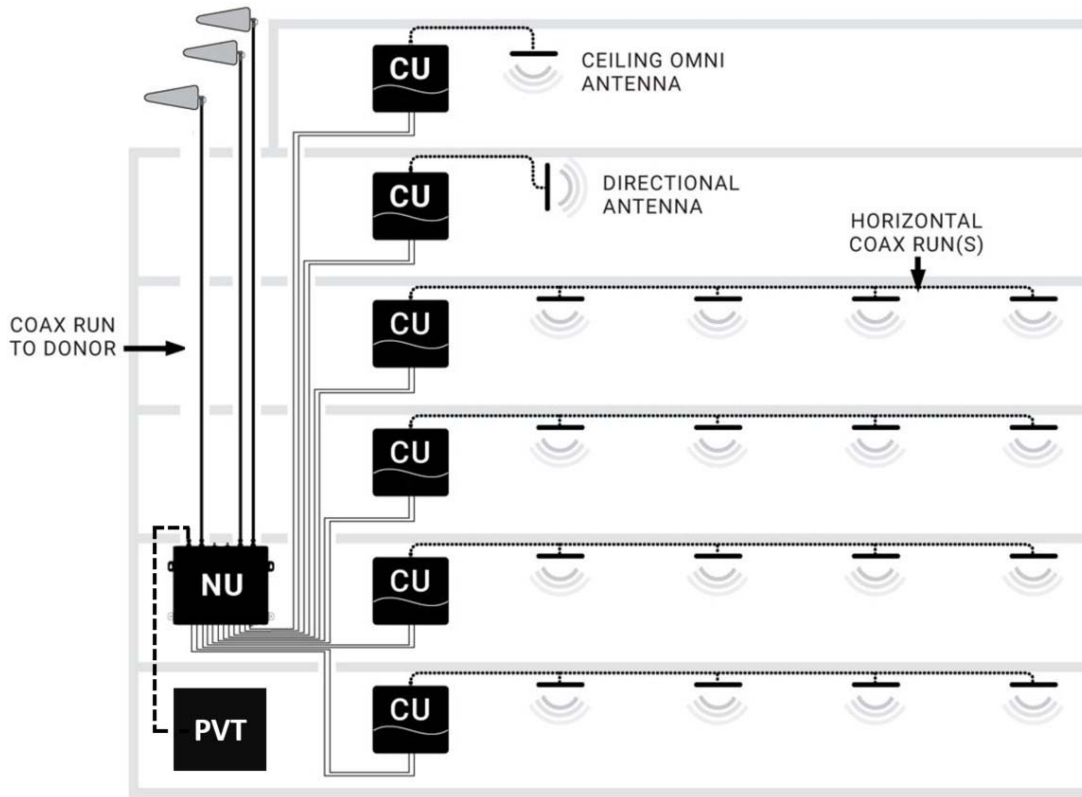

Real World Examples

1. Off Air Install, 75K ft² building

In this example, Cel-Fi QUATRA is providing wireless coverage for three cellular carriers and one optional CBRS private wireless network in a six story 75,000 ft² building. Individual LPDA antennas are located on the top of the building to ensure the best signal-to-noise ratio for all cellular carriers, and the enabled CBRS port on the NU is connected to a PVT signal source. A Coverage Unit is placed on each floor, and a distributed antenna system (DAS) field is run out from each CU to provide great coverage.

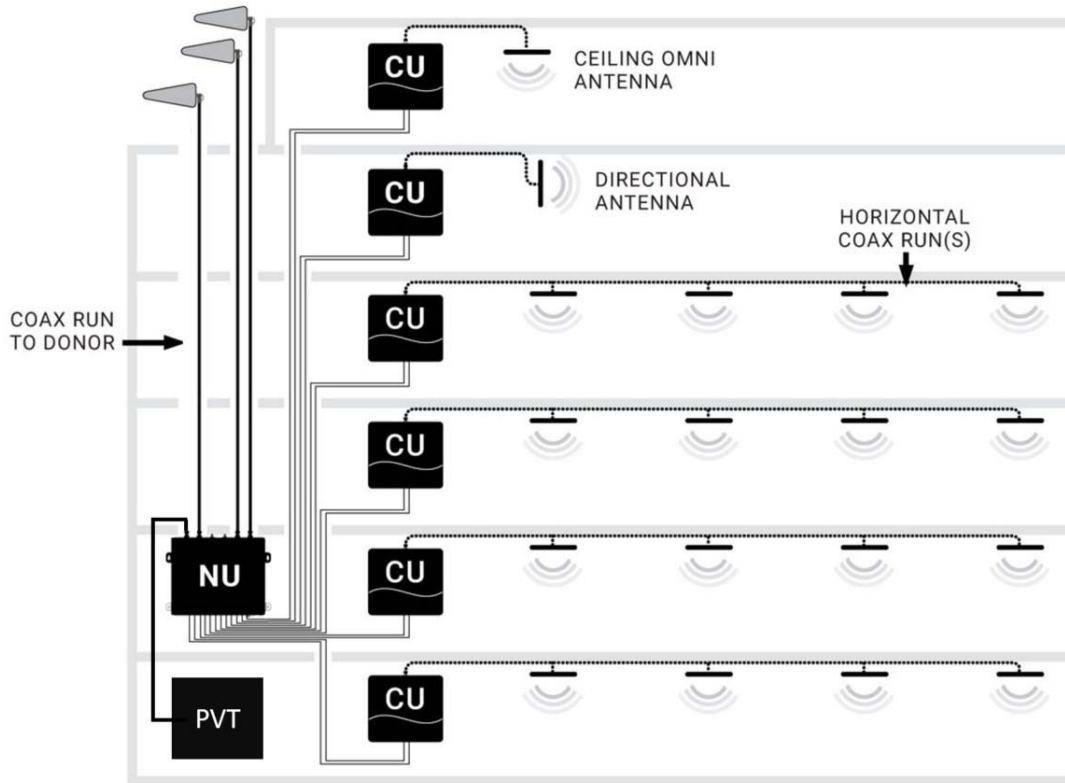

2. Supercell Install, 300K ft² building

This building did not have adequate donor signals for the carriers, so small cells were chosen as the signal sources. The system is comprised of four (4) QUATRA 4000c systems served with one small cell from each service operator. The small cell signals are split and input to each QUATRA 4000c NU. From the QUATRA 4000c NU the signals are distributed to CUs on each floor and then horizontally to a DAS field, providing coverage to the building.

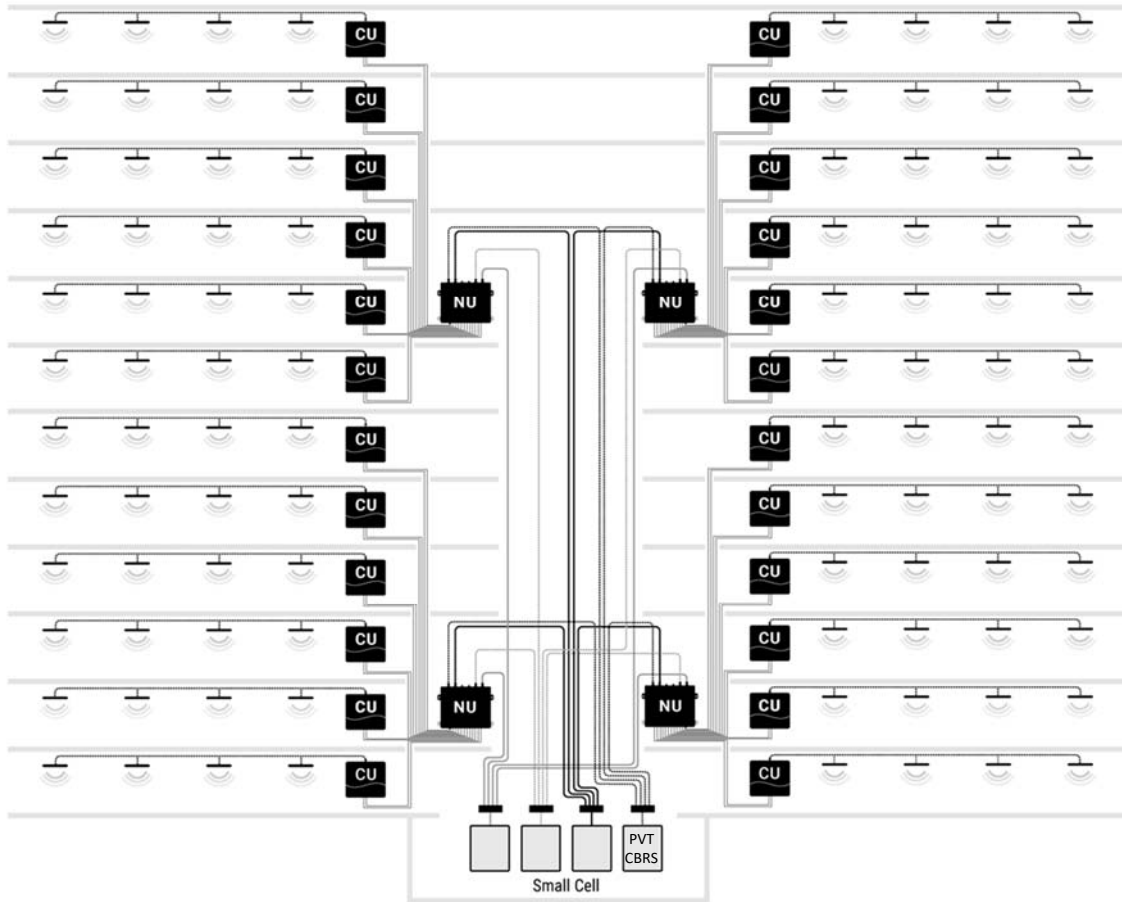

3. Hybrid Install, Off-Air + Small Cell

In this example, the building site has excellent (exterior) network service for two cellular carriers, but the other carrier outside signals are very poor. The System Integrator has decided to use a hybrid approach, taking off-air signals from the two carriers with good service and implementing a small cell for the remaining carrier plus a PVT CBRS signal source.

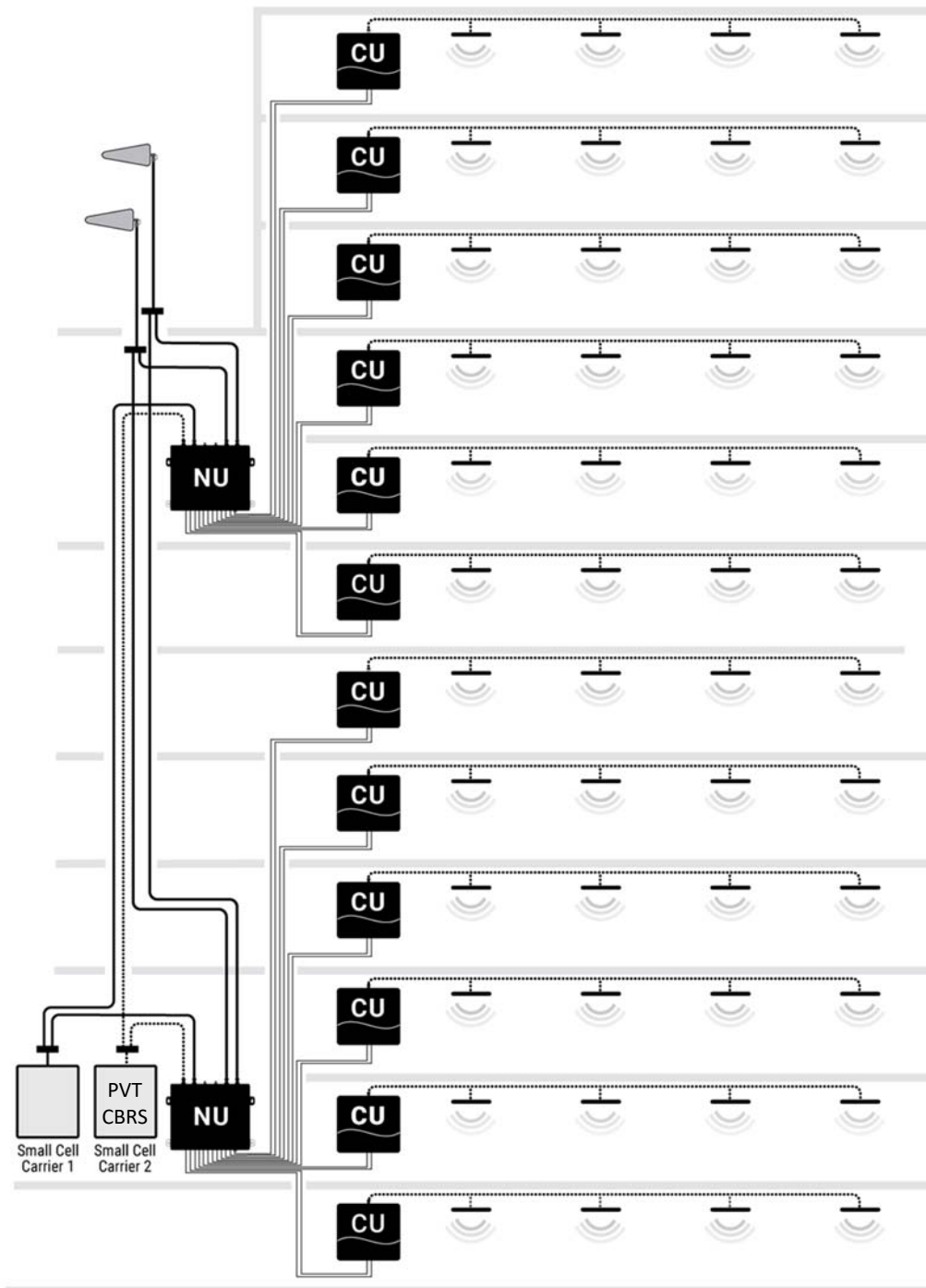

Cel-Fi QUATRA 4000c Key Features

- Carrier Grade, FCC-certified Smart Signal Booster
- Support for AT&T, Verizon, T-Mobile and CBRS
- Relays two (2) bands per operator, and one (1) CBRS channel
- Independent donor ports for each operator allows for independent antenna optimization
- Single combined (CU) server port enables driving either a serving antenna or passive DAS field
- 100 dB max system gain
- 140MHz total relay bandwidth
- Support for up to six (6) CUs (twelve with a HUB)
- N-type RF connectors (donor and server)
- Internal modem for remote management (SIM slot access)
- Industrial aluminum powder-coated housing
- Up to 100m cable distance between NU and CU (using Cat5e), or 150m using 22/23AWG CAT6/7
- QUATRA Range Extender (QRE) doubles CU cable length (up to 300m)
- 20-22 dBm uplink power per operator per band
- 16 dBm downlink power per cellular channel, and 20 dBm for CBRS.

Cel-Fi QUATRA 4000c Service Agreement

- Every NU will be bundled with a 1-year product Service Agreement
- The Service Agreement may be renewed on an annual basis
- The Service Agreement includes a 1-year SIM service plan, if you chose to use the internal modem for your WAVE Portal connection.
- Upon request once the system installation is complete, Nextivity will review key system KPI's and provide feedback on the installation.
- Nextivity will monitor systems for any alarms and perform Level 1 remote troubleshooting for each alarm.

Learn more about our [Service Agreement](#).

04. Hardware Components

Cel-Fi QUATRA 4000c is a modular solution with two (2) foundational components: the Network Unit (NU) and the Coverage Unit (CU). In traditional DAS terminology, these could be known as the Head End (NU) and the Remote Unit (CU).

Power is provided to the entire system through AC power at the NU. The CUs are powered via Power over Ethernet (PoE), and therefore do not require a separate power source at their location. Signal source is brought into the system at the NU, via a wired connection, like a small cell, or through a donor antenna and an RF connection.

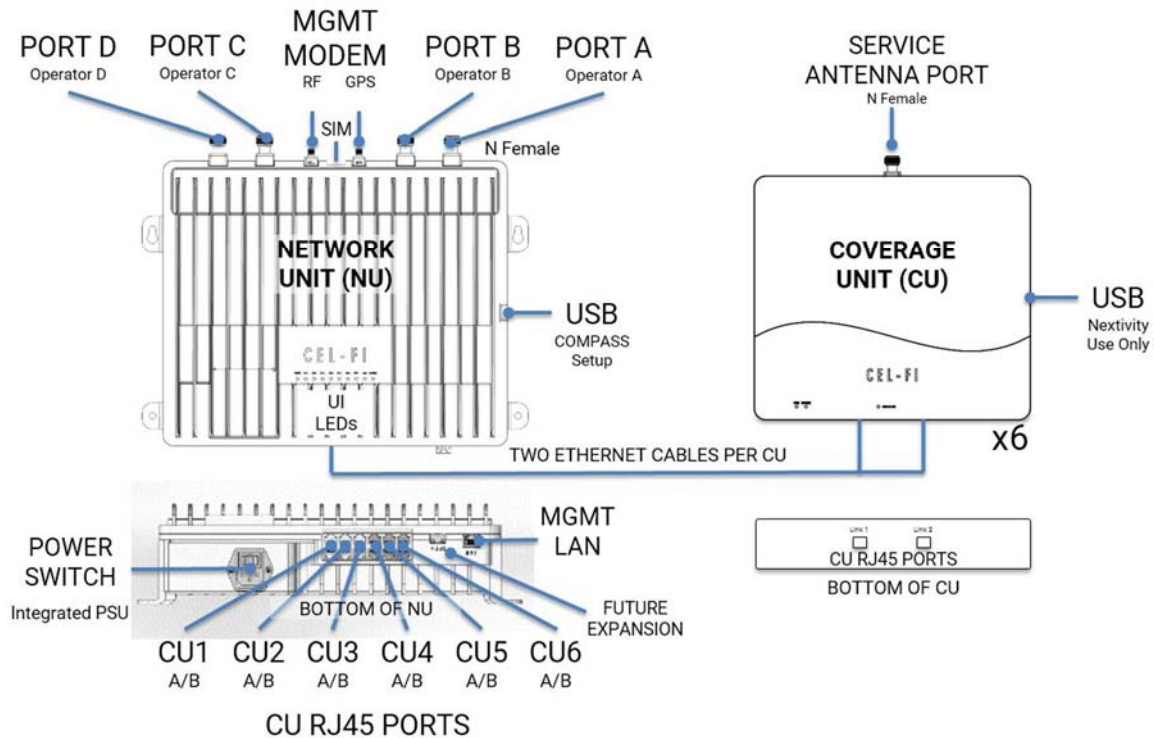

Network Unit (NU)

The Network Unit, referred to as the NU, is the head end for the QUATRA 4000c system. The signal sources (one for each port/carrier) are connected to the NU. Then they are digitized and distributed over two Category “Ethernet” cables to the Coverage Units (CU).



QUATRA 4000c Network Unit

Note: Only cellular signals may be connected to the donor ports. Other types of radio signals will not work, and may damage the system.

The NU has four (4) N-type RF ports on the top. Each RF port is assigned, and marked, to a specific carrier.

There are two (2) SMA-female ports on the top of the NU. One functions as the external antenna connection for the unit's internal cellular modem, and the other is for GPS. (The GPS port is for future functionality)

Power

- AC Power Supply (inside the NU)
- AC power cord

Physical Interface

- RJ45 ports (13)
- Twelve RJ45 ports (2 for each of the 6 CUs)
- One LAN port for remote management
- SFP+ module dock (for use with a Fiber HUB)
- N-type Female RF Ports (4) for Donor Antennas
- One for each carrier
- SMA ports (2 for the internal LTE modem)

User Interface

- LED interface (front) to indicate system status. (For detail on the LED go to LEDs.)
- Power
- CU1
- CU2
- CU3
- CU4
- CU5
- CU6
- SFP+
- LAN
- MODEM

Power Supply Cable

Coverage Unit (CU)

The Coverage Unit (CU) receives the digitized cellular signal from the NU, converts back to RF, amplifies, and distributes the service from its RF port. Service can be deployed through a single connected antenna, or through a DAS field.



QUATRA 4000c Coverage Unit

Accessories

QUATRA 4000 FIBER HUB

Model Number: Q40-1234FNU

The HUB functions much like an NU, except it does not have donor antenna ports. It connects to an NU over optical fiber cable (up to 2km) using SFP+ modules, and it adds up to six more CUs to an NU (twelve CUs total). Please note that the QUATRA 4000 HUB works with the Q4000, 4000i, and 4000c models.



QUATRA 4000 FIBER HUB

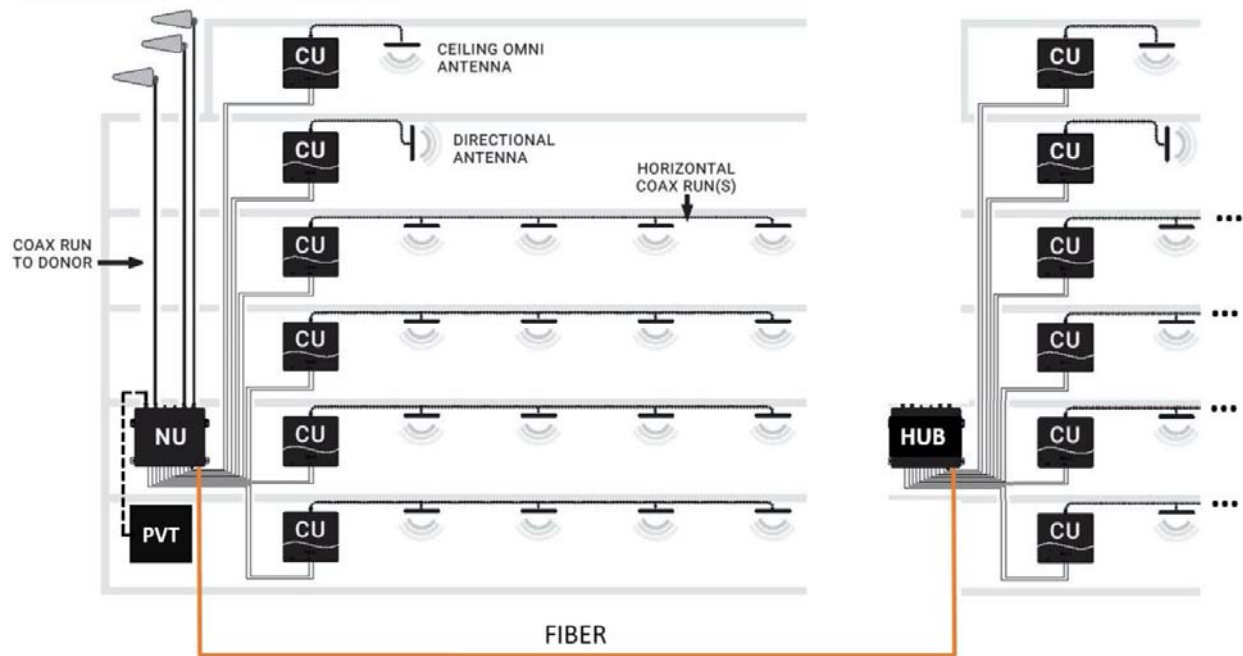

QUATRA 4000 Range Extender and Fiber Range Extender

The QUATRA Range Extender (QRE) unit is a device that extends the standard 100 meter Ethernet cable length from NU to CU up to 200 meters with Cat5e, or up to 300m if CAT6/7, 23AWG cable is used. It is inserted in-line between the NU and CU, and requires no external power. The RJ45 connectors are on each side (two per side). Traditional Ethernet extenders will not work with QUATRA.

The QUATRA Fiber Range Extender (fQRE) system is a similar pair of devices that convert QUATRA 4000 specific signaling to optical fiber and then back to Ethernet for up to an additional 2km of CU cable length.

Please note that the QUATRA 4000 QRE and fQRE both work with the Q4000, 4000i, and 4000c models.



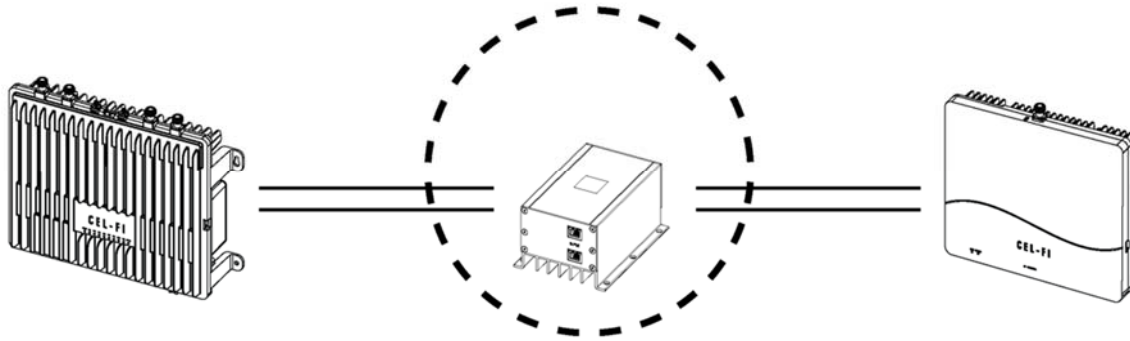

Donor Antennas

The donor antennas are used to provide off-air signals to individual carrier donor input ports. The objective is to provide the best quality carrier signals to the NU. A variety of donor antennas are available from Nextivity. The right donor antenna choice can make the difference between a good outcome and a great outcome. Please refer to other antenna-specific documents for choosing the right donor antenna.

Cel-Fi LPDA-R Antenna

Model Number: A62-V44-201

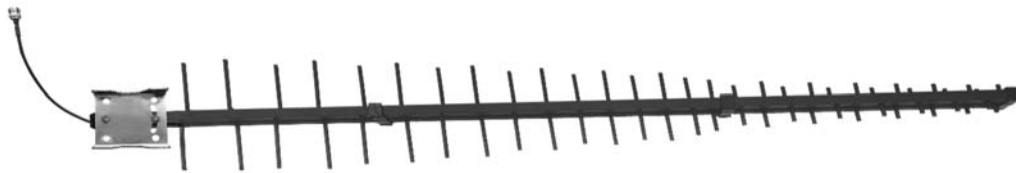

Cel-Fi LPDA-R Antenna

Nextivity recommends its LPDA-R antenna for use as a great donor antenna for most situations. Learn more about our [Antenna](#) options.

Server Antenna

The server antenna connects to the RF port on the CU.

Server Antenna connects here

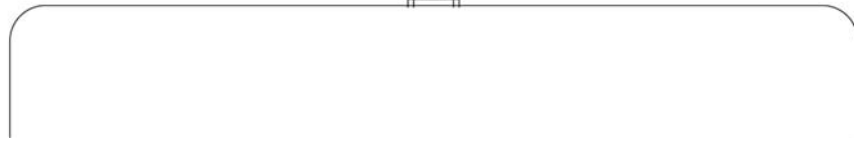

Server Antenna port

A variety of Server antennas are available from Nextivity. Visit the [Antenna Product](#) page for details and updates.

Couplers

RF couplers or tappers may be used with Coverage Units when multiple service antennas are desired. Careful system design should be implemented to insure sufficient power levels into all antennas.

The WAVE Portal

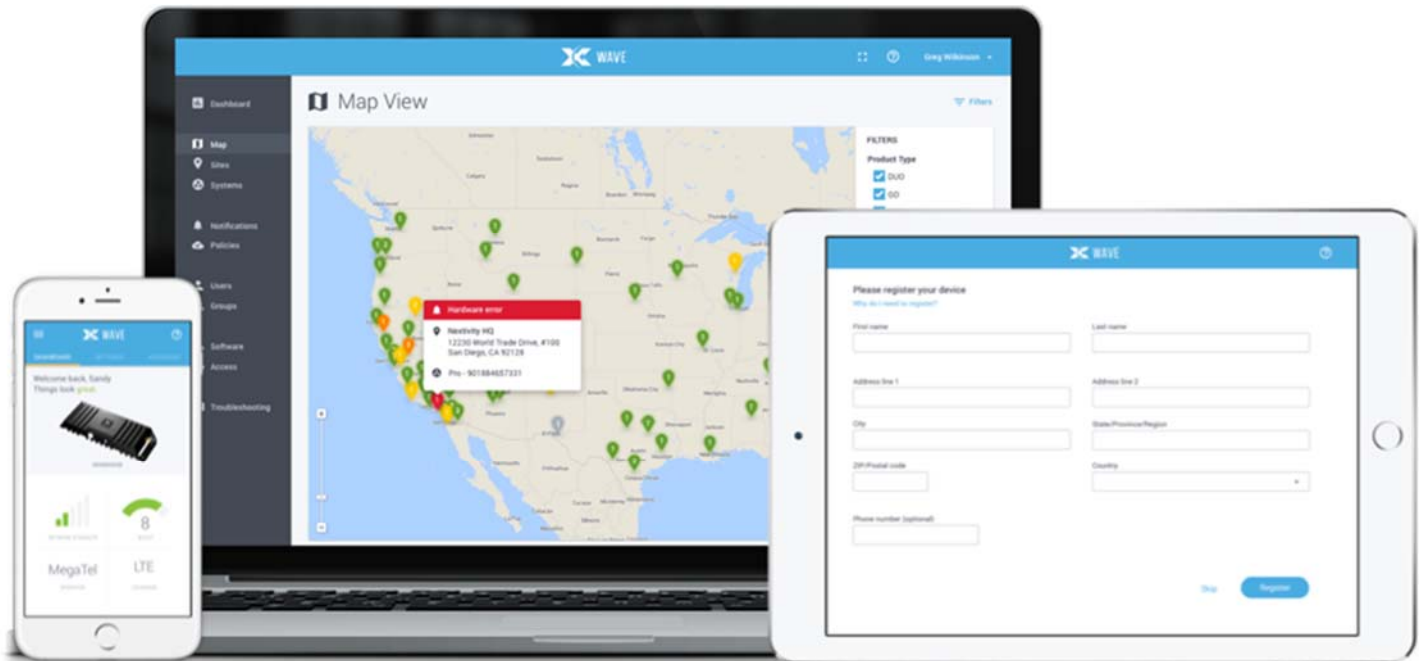

Introduction

The WAVE Portal is Nextivity's SOC2 Type 1 compliant cloud-based software platform from which Cel-Fi apps and connected devices are hosted and driven. Current-generation Cel-Fi products feature embedded connectivity that allows them to connect to the WAVE cloud. The WAVE portal and apps are used to facilitate software updates, registration, commissioning, installation, optimization, and troubleshooting. The Cel-Fi WAVE platform continues to expand in features and function.

In order to use the WAVE portal and related capabilities, you must be registered with the system.

- [Request access to the WAVE Portal](#)
- [Login to the WAVE Portal](#)

The portal constantly monitors your systems and tells you how to resolve alarms or improve performance with explicit guidance, all from your smartphone or computer browser. See Cel-Fi training modules for easy to understand video and slide tutorials.

Connecting your 4000c to the WAVE Portal

There are two ways to connect the NU to the cloud. With either method, you should see your system on the portal by its NU serial number once it is connected using either method below, and powered on.

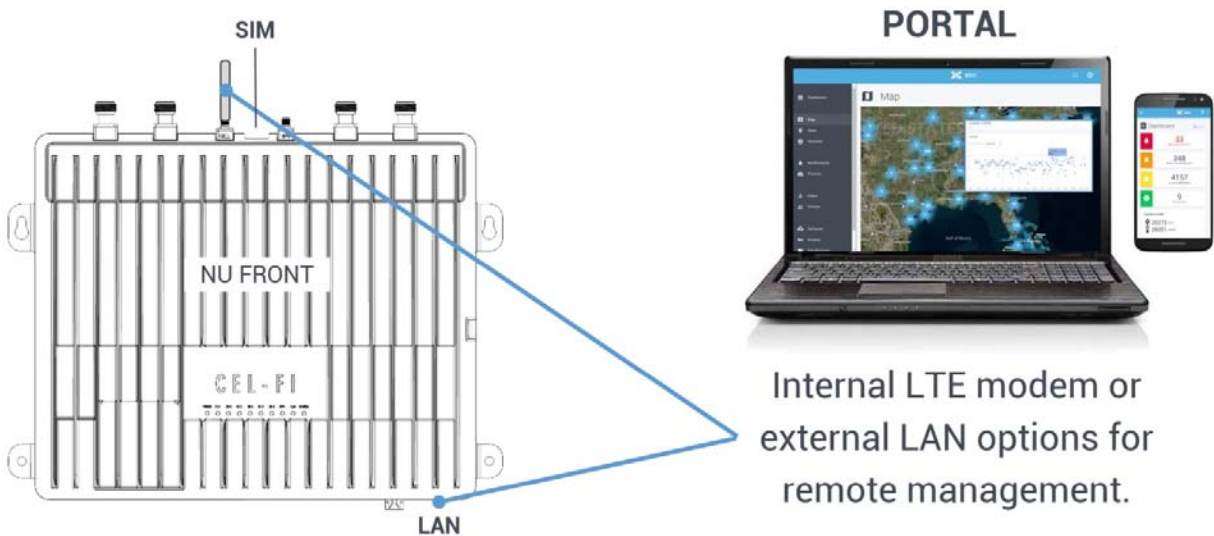

Internal LTE modem or external LAN options for remote management.

If you do not see your NU on the portal (**New Systems** page or **Systems** page), then you need to register it with your portal login account. Click on the portal **Access** tab (lower left portal screen), and select the **Request Access** option under the upper right screen **Options** menu. Input the NU serial number and the SKU from the NU carton label, and access is immediately granted. If the NU carton has been discarded, contact your point of sale or Nextivity Support to obtain access.

LAN Connection Method:

The first method is by connecting a LAN Ethernet cable to the LAN port on the NU, and setting the LAN firewall settings as described in the settings guide. The LAN LED should be solid green, or blinking green to indicate traffic. You may also test the firewall settings using the WAVE Field Tool Windows program.

- [Learn More about LAN Firewall Settings](#)
- [WAVE Field Tool](#)

MODEM Connection Method:

The second method is to use the preconfigured LTE modem that is built into the NU (this requires that no Ethernet cable is connected to the NU LAN port).

Screw on the provided SMA cellular antenna onto the CELL modem port located on the top center of the NU, or use a coupler to tap into the RF of a donor port cable. Note that the GPS port is currently unused and no GPS antenna is required.

Next, find the pre-provisioned SIM card that came with the NU and carefully insert it in the SIM card slot next to the CELL SMA antenna port. Your SIM card may have been factory inserted (if so you will see the SIM card in the slot). Damage may result if the card is pressed into the slot with excessive force.

In this modem mode, the LAN LED should be OFF and the MODEM LED should blink Green-red to indicate normal operation.

Alarms, Alerts, and Policies

Cel-Fi systems support a variety of standard alarm conditions. Policies are your own account lists of alarms, alarm severities, and whether you want them displayed on the portal (console), or emailed or texted to individuals or groups. Each new user (company) is given a “Default Policy” with the basic alarms already in it. You may edit this policy as you please, or create new policies. For example, you may want different policies for different regions. It is the responsibility of policy holders to add new alarms that may be introduced with new products. It is recommended that all of your policies have all possible alarms, so they can properly report alarms for all products where alarm options may differ.

Current alarms and the last 100 alarms history are displayed on the Systems page for each installed system. For a universal alarms page of all alarms across all systems you have access to, please refer to the Notifications tab.

For information on how to resolve any alarm, simply select the alarm notification in the Alarm History window.

Below is a non-exhaustive list of basic alarm categories.

Main Alarms

Category	Description	Meaning
HW Error	NU/CU Hardware Error	Self-Test Failed
HW Error	NU/CU Overheating	Unit overheating
Donor signal	Donor too weak	Donor signal too weak to be detected
Donor signal	Donor too strong	Donor signal too strong
Donor signal	Small Cell not Detected	Small Cell not detected in Small Cell Mode
Donor signal	Antenna Positioning Req.	Donor antenna aiming should be performed
CU Cable error	CU# Link Lost	The cable to CU# is disconnected
CU Cable error	Ethernet link error on CU#	The data to CU# exhibits data interference or is weak
System/Unit Shutdown	Manual unit shutdown	A reminder that a unit has been manually shut down
WAVE Portal	System Not Online	The portal can no longer see the system
Location Lock	The system has been moved	A system has been moved and should be reregistered
PS Alarms	Public Safety FACP Alarms	Standard Fire Alarm Control Panel alarms
PS Alarms	Public Safety Sys Alarms	Additional QUATRA detail alarms
Other Misc. alarms		

User Profiles

User profiles are created in the Wave Portal. User Profile is where individual account information is stored, as well as any Group assignments.

Installation

***Important:** Before any permanent installation, make sure all the components are planned and accounted for, as well as any wiring, cabling, power, mounting, antenna placements, and system access.*

Overview

Several things need to be determined as part of installation planning and preparation.

- Perform indoor and outdoor signal surveys to understand current signal problems and to assess candidate donor antenna locations (the Nextivity COMPASS signal survey tool is purpose-built for survey activities)
- Determine where the NU(s) will be mounted
- Ensure an adequate power source (outlet)
- Determine donor signal sources and cabling/routing
- Determine CU cabling/routing pathways (Low-voltage/Ethernet routing rules)
- Determine where the CU(s) will be mounted and how coverage is to be distributed
- Determine if the (included) Mini Panel Antenna will be used or a DAS field, for each CU
- If coaxial cable and antennas are planned for use then that should be considered at this point

***Note:** For signal surveys, or to find candidate locations for donor antennas, we recommend Nextivity's COMPASS XR tool. Ask your distributor for more information or visit us at www.cel-fi.com*

***Note:** IBWAVE or the Nextivity's BOM Estimator design tool (or other RF planning tools) are not required but are a good way to ensure the best performance outcomes. iBwave vex and template files may be found on the Nextivity product pages.*

- [BOM Estimator Tool](#)

Installing the NU

Mounting

The Cel-Fi QUATRA NU is designed for simple wall mounting, typically in an IT room with coaxial cable access to donor antennas that are installed on the roof, or any other exterior location with a quality donor signal from each cellular operator. The location should also have an available electrical outlet within reach of the supplied power cord.

Mounting accessories, including screws and anchors, for common material types (drywall, plywood, etc) are included with each NU.

Equipment Required for Mounting

- Drill
- Drill bit extender (3"+)
- Hammer
- Pencil, or other similar marker
- Level

Caution: Make sure the area behind any surface is free of electrical wires or other dangerous elements prior to drilling.

The QUATRA 4000c NU has four (4) secure mounting tabs, two on each side. The two topmost tabs have been keyholed.

Note: The Mounting Instructions below use the standard drywall mounting anchors and screws included with the unit. If the NU is to be mounted onto other surfaces, make sure the appropriate anchors and screws are used (not included).

1. To mount the NU, first determine the approximate location on the wall for the unit.

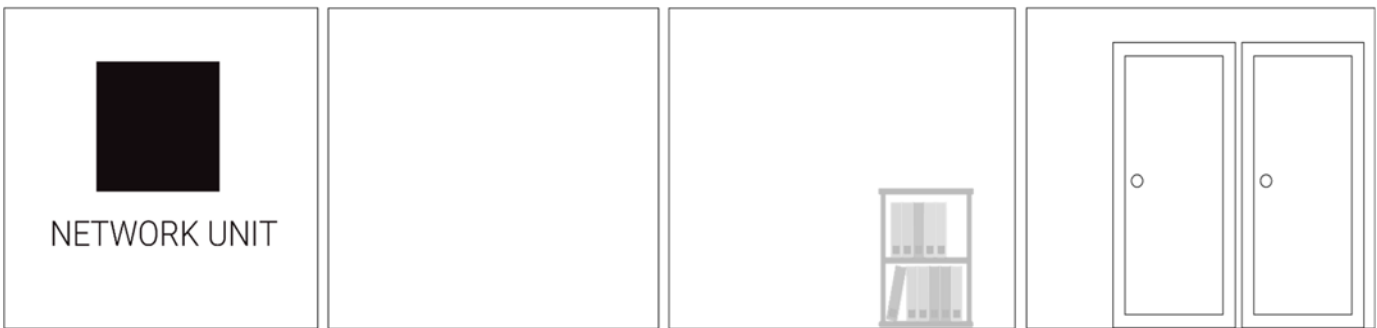

2. Hold the unit up on the wall and, using a pencil or similar marker, mark one of the top (right or left) points.

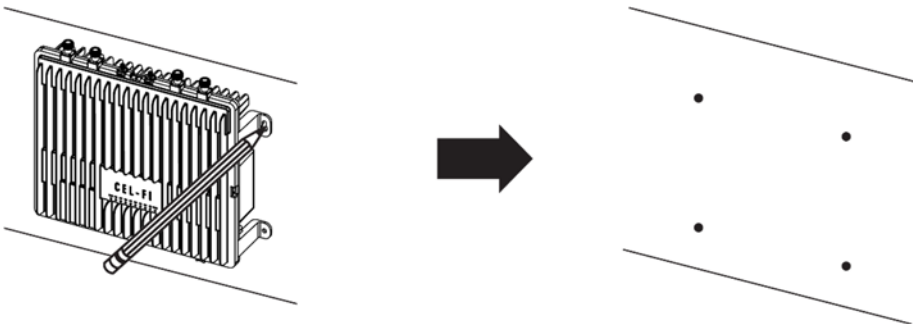

3. Drill the holes for the anchors.

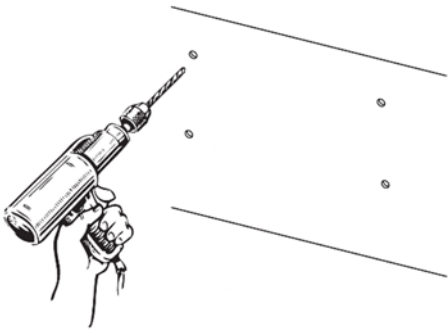

4. Hammer in the anchors.

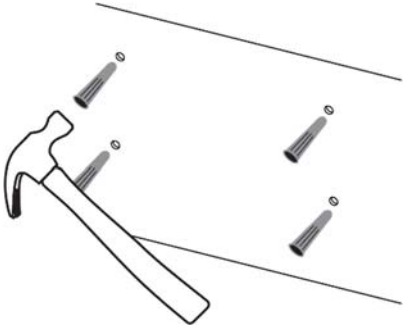

5. Partially screw in the top two screws.

6. Hang the unit from the top two screws, through the eyeholes. Adjust the unit to level and then tighten the screws.

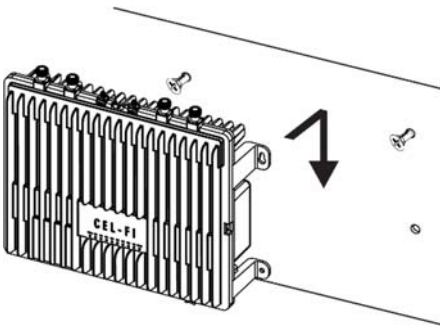

7. Screw in the bottom two screws.

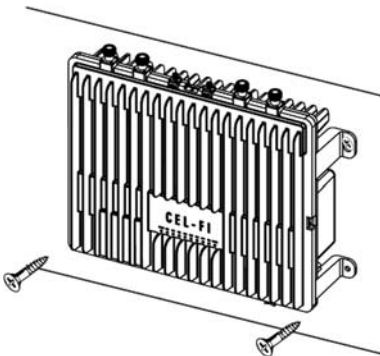

8. Mounting is complete.

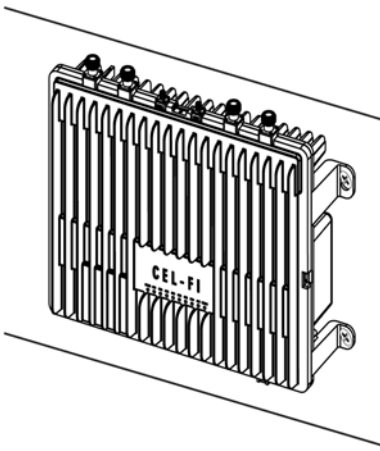

Connecting Donor Sources

The QUATRA 4000c has four independent RF ports for connecting the donor signals. Each port:

- Is an N-type Female connector
- Is specific to the supported carrier
- Is designed to support a variety of band configurations

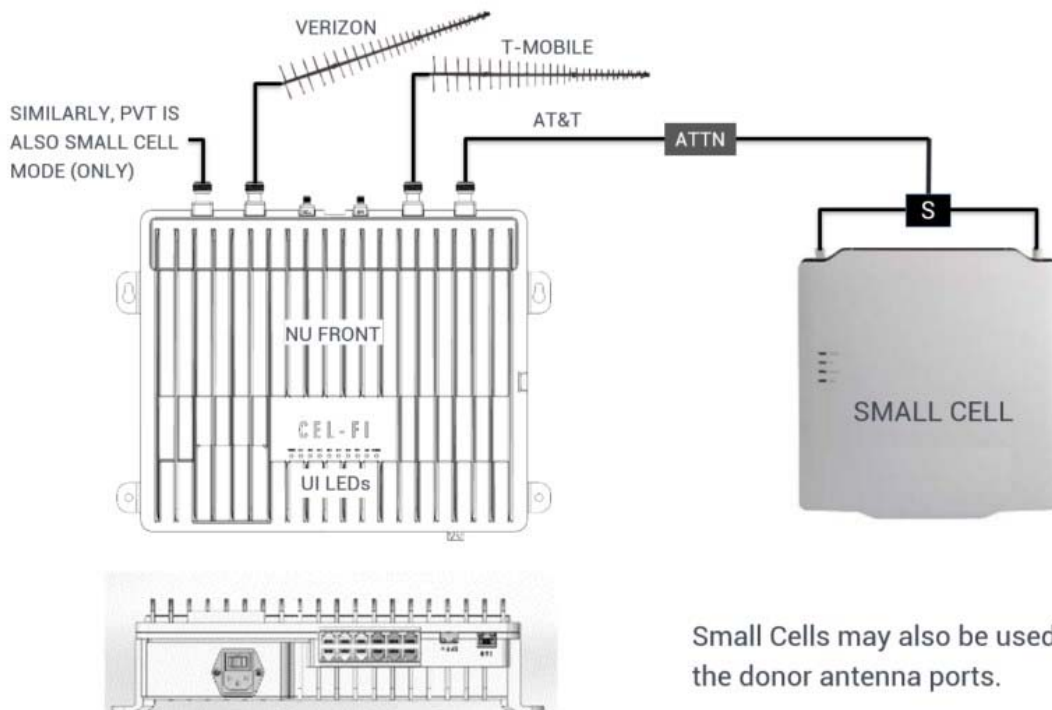

Small Cells may also be used on any of the donor antenna ports.

Cellular Donor Antenna Input

The three carrier RF ports can be fed by a donor signal consisting of either a small cell or an antenna. The PVT (CBRS) port must be fed by a CBRS small cell (CBSD).

Note: Small cell inputs and off-air inputs can be used in the same system, but not for the same donor port.

The donor antenna is used to collect the donor signal from the external (over-the-air) carrier network. Better donor signals lead to better customer experiences, improved voice quality and faster data throughput. A signal-to-noise ratio (SiNR) of > 5 dB is strongly recommended for each given carrier's source signal, however lower quality signals will work if that is all that is available for the site. Better SiNR leads to better throughput and "bars" of signal strength on cellphones.

Each donor antenna should be mounted safely and securely where it can access the desired cellular network. A coaxial cable connects the donor antenna to the NU's RF port for each given carrier.

Please watch our donor antenna best practices video by clicking on the link below. This video and many other videos and webinars may be found under the Webinars link at the bottom of www.cel-fi.com

<https://www.cel-fi.com/casestudy/cel-fi-quatra-antenna-selection/>



Cellular Small Cell Donor Input

If a small cell is used as the donor source then it should be connected at this time. The recommended input signal level for a small cell, after connection losses and attenuation, should be between -75 and -95 dBm RSRP into the NU donor port for that operator. It is easy to verify this power level using the Radio Data page on the WAVE portal once the system is operational.

Note: For more information about connecting small cells, see the QUATRA Approved Small Cell Guide.

Private Network (PVT) CBRS LTE Donor Input

QUATRA 4000c is also capable of providing service for an in-building Private LTE network. CBRS is more secure with better mobility, latency stability and quality than Wi-Fi. It is designed to spur innovation in connectivity and IoT applications. It occupies 150MHz of shared spectrum in the 3.5 GHz C-band, also known as Band 48 (B48).

To enable this port and explore CBRS private network options, please contact Nextivity or your point of sale.

Connecting your 4000c to the WAVE Portal (cloud NMS)

There are two ways to connect the NU to the cloud. With either method, you should see your system on the portal by its NU serial number once it is connected using either method below, and powered on.

LAN Connection Method:

The first method is by connecting a LAN Ethernet cable to the LAN port on the NU, and setting the LAN firewall settings as described in the settings guide (see the link below). Once the NU is powered ON, the NU will automatically reach out to the WAVE Portal in the cloud and the LAN LED should be solid green, or blinking green to indicate traffic.

If you do not see your NU on the portal within ten minutes of powering up the NU (**New Systems** page or **Systems** page), then you need to register it with your portal login account. Click on the portal **Access** tab (lower left portal screen), and select the **Request Access** option under the upper right screen **Options** menu. Input the NU serial number and the SKU from the NU carton label, and access is immediately granted. If the NU carton has been discarded, contact your point of sale or Nextivity Support to obtain access.

If you still are unable to see your NU on the portal, you may use the WAVE Field Tool link below to test the portal firewall connection using a Windows 10 or later PC. This tool has many features, and the connection test emulates the NU connection to test your firewall.

- [Learn More about LAN Firewall Settings](#)
- [WAVE Field Tool](#)

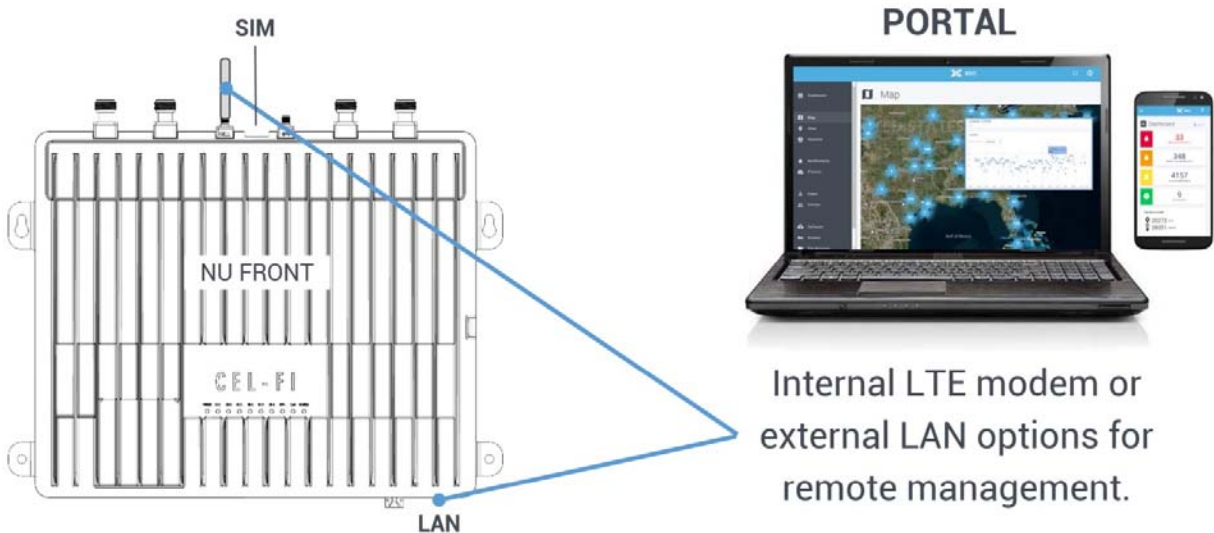

Internal Modem Connection Method:

The second method uses the internal LTE modem built into the top center of the Network Unit. You will notice two SMA connectors. Please locate the small SMA antenna that came with your NU and attach it so the CELL SMA port on the top of the NU. The GPS SMA port remains unconnected and is for future use.

A SIM card with one year of prepaid service should be pre-installed in the SIM card slot. If you do not see a SIM card in the slot, then locate it in your product packaging and carefully insert the SIM into the slot as indicated on the housing. Do not force the card into the slot or damage may result. This SIM is paired with QAUTRA and will not work in other devices.

If you do not see your NU on the portal within ten minutes of powering up the NU (on the **New Systems** page or **Systems** page), then you need to register it with your portal login account. Click on the portal **Access** tab (lower left portal screen), and select the **Request Access** option under the upper right screen **Options** menu. Input the NU serial number and the SKU from the NU carton label, and access is immediately granted. If the NU carton has been discarded, contact your point of sale or Nextivity Support to obtain access.

Once the NU is powered ON, the NU modem will automatically reach out to the WAVE Portal in the cloud and the MODEM LED should blink red-green to indicate a successful cellular connection. If you do not have a viable cellular signal at the NU location, you may remove the SMA antenna from the CELL port and connect the CELL modem port to one of the donor antenna feeds using an RF coupler.

Power

The QUATRA 4000c system is powered from the Network Unit (NU). The NU comes with a power cord that plugs in to the back of the unit. The Coverage Units (CU) are Powered-over-Ethernet (PoE) and therefore do not have independent power supplies that need to be plugged in.



The entire system should be installed before the system is powered-on.

Note: It is recommended to zip-tie or otherwise secure the power cord once the system is powered-up, to prevent accidental unplugging.

Installing CUs

Wall Mounting

The Coverage Unit (CU) comes with a wall mounting bracket in the box. To mount the QUATRA 4000c CU simply follow these steps:

1. Determine the mounting location. ^{[1][1][1][1]}_{[SEP][SEP]} Note: Whenever mounting any Cel-Fi gear on a wall or ceiling make sure the area is free of any dangerous electrical wires, other safety hazards, or any other objects that could be damaged or effect the quality or stability of the mounted unit.
2. Position the QUATRA 4000c CU wall mount on the wall in the desired mounting location.

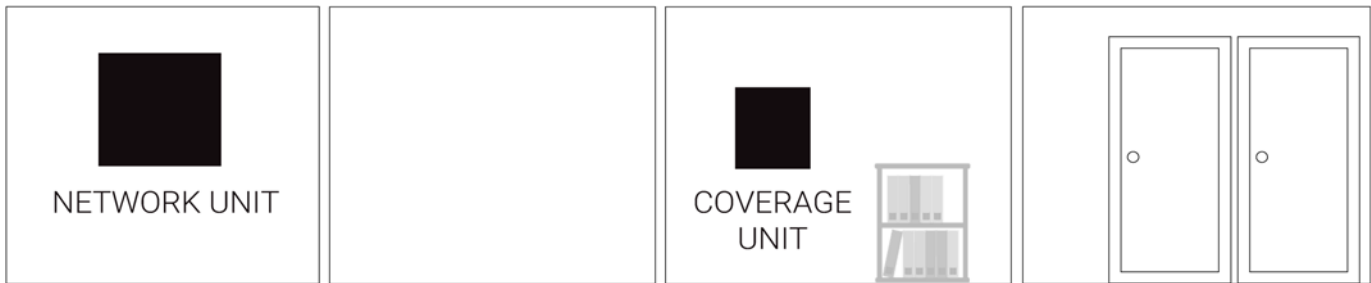

3. Holding the mounting bracket in place, mark hole locations with a pencil.

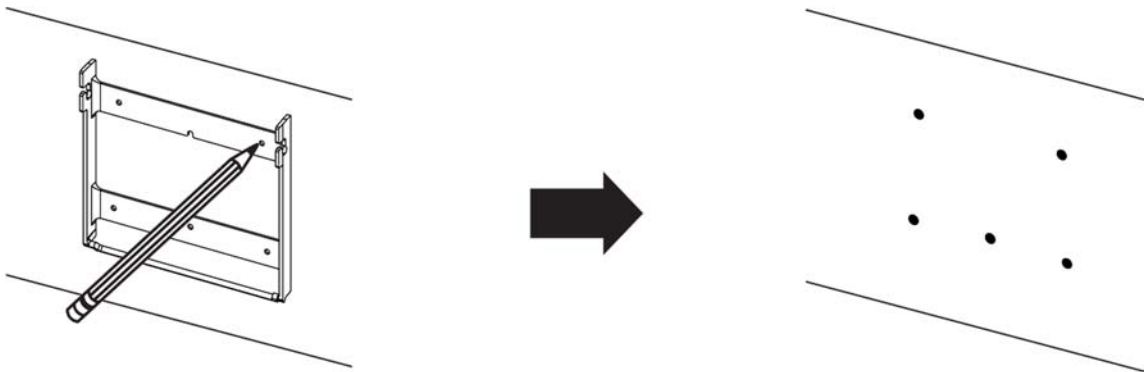

4. Drill the holes.

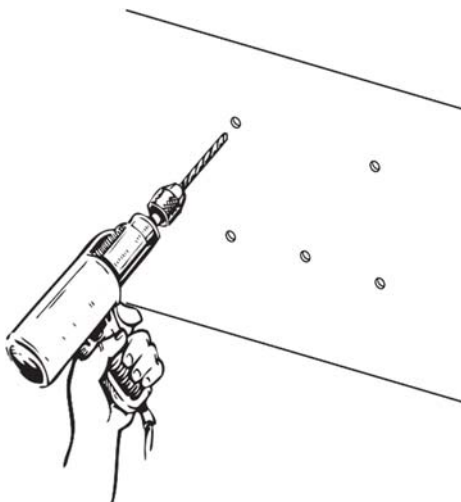

5. Hammer in the anchors.

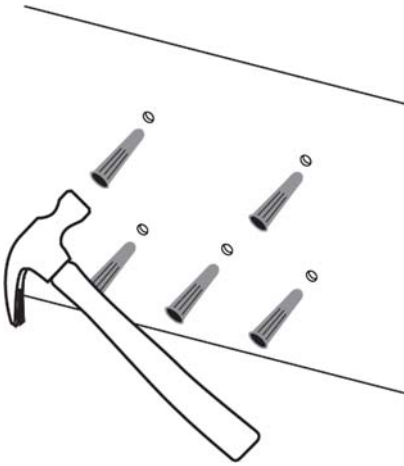

6. Attach the bracket to the wall with the included screws.

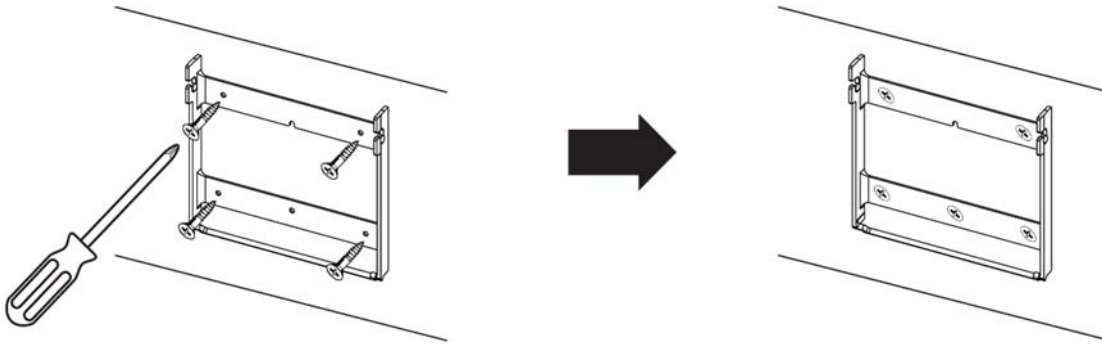

7. Once the bracket is firmly attached to the wall, the CU can be attached to the bracket.

8. With the bracket in place, attach the CU.

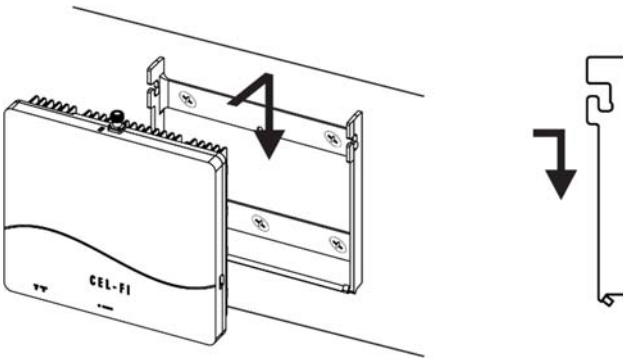

9. Tighten both Locking Screws to ensure the CU is securely attached to the mounting bracket. The CU may also be mounted to many surfaces with appropriate Unistrut hardware.

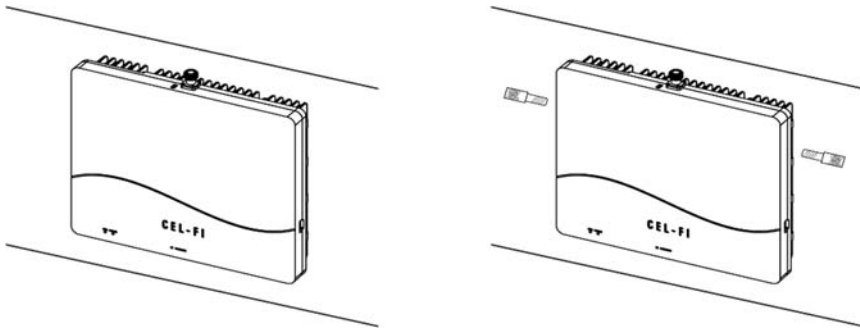

Connecting Server Antenna(s)

The CU has an N-type connector on the top of the unit for attaching an antenna. An Omni-directional antenna may be used, or a coaxial cable can be connected with a series of passive antennas attached.

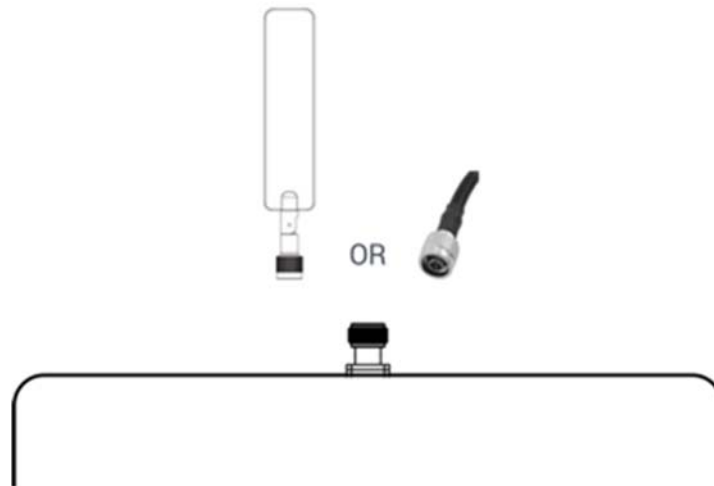

Connecting Server Antenna or Cable

Connecting NU and CUs

Each CU connects to the NU using two category cables (Cat5e or better). QUATRA signaling is not Ethernet compatible, so routers, switches, bridges or other active Ethernet devices may not be used. Patch panels or punch-down blocks may be used.

CU assignment

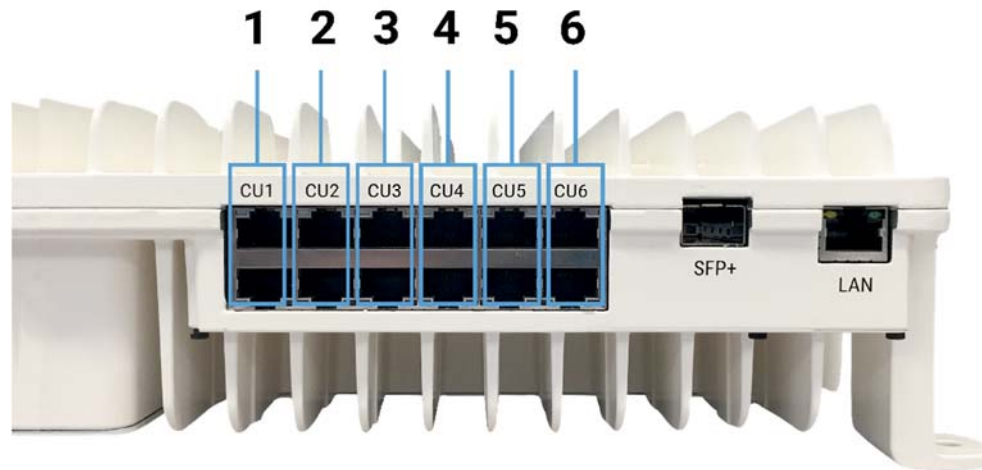

CU port assignment on the NU

Follow general category cable routing practices as follows. The system constantly monitors all CU cables and a red LED means that the NU cannot communicate with a CU properly.

General CU Cabling Rules:

- QUATRA uses category cables, commonly used as Ethernet cable. However, QUATRA cables are NOT ETHERNET/LAN COMPATIBLE!
- CU cables must pass 1000BaseT (gigabit).
- CU cables may pass through patch panels, but not active equipment such as routers or switches that will not understand QUATRA signaling.
- CU cables should follow normal low voltage cable pathways.
- Do not run CU cables alongside AC power lines or other sources of interference such as LED lighting.
- Crossing power lines at 90 degrees is OK.
- Only a QUATRA Extender may be used to extend a CU cable in length. Off-the-shelf Ethernet Extenders or Fiber interfaces will not work. Install the QRE halfway along the cable.
- CU cable lengths up to 150 meters (150m+150m with a QRE) are possible with thicker gauge 22/23 Category cables.
- ONLY USE PURE COPPER CATEGORY CABLES. CCA (Copper Clad Aluminum) is not suitable for PoE applications.

Troubleshooting:

- Check that each CU cabling rule has been satisfied.
- Debris in the port – blow off the connector/port and insert the connector a few times to “clean” the contacts.
- Test the port on the NU or CU to see if there is movement. If there is any movement then the port may be damaged.

- Plug the CU directly into the NU using a short known good machine-made Category cable to determine if the hardware or cabling is at fault.
- Redo the terminators on either end of the cable in alarm.
- Consider punch-down Ethernet Surface Mount Boxes to remove the human cable termination component. This is more in line with standard IT practices that favor screw or punch-down terminations and machine-made cables. They are more reliable and end-point machine made jumpers are easily swapped out if they fault.

Check that the RJ45 terminators are correct for the cable used (cable diameter spec for example).

Using a QRE

If category cable lengths greater than 100 meters from NU to CU are required (150m if using 22/23 AWG CAT6/7 cable), a QUATRA RANGE EXTENDER (QRE-4K) may be used in the middle of the cable run to achieve lengths up to 300m.

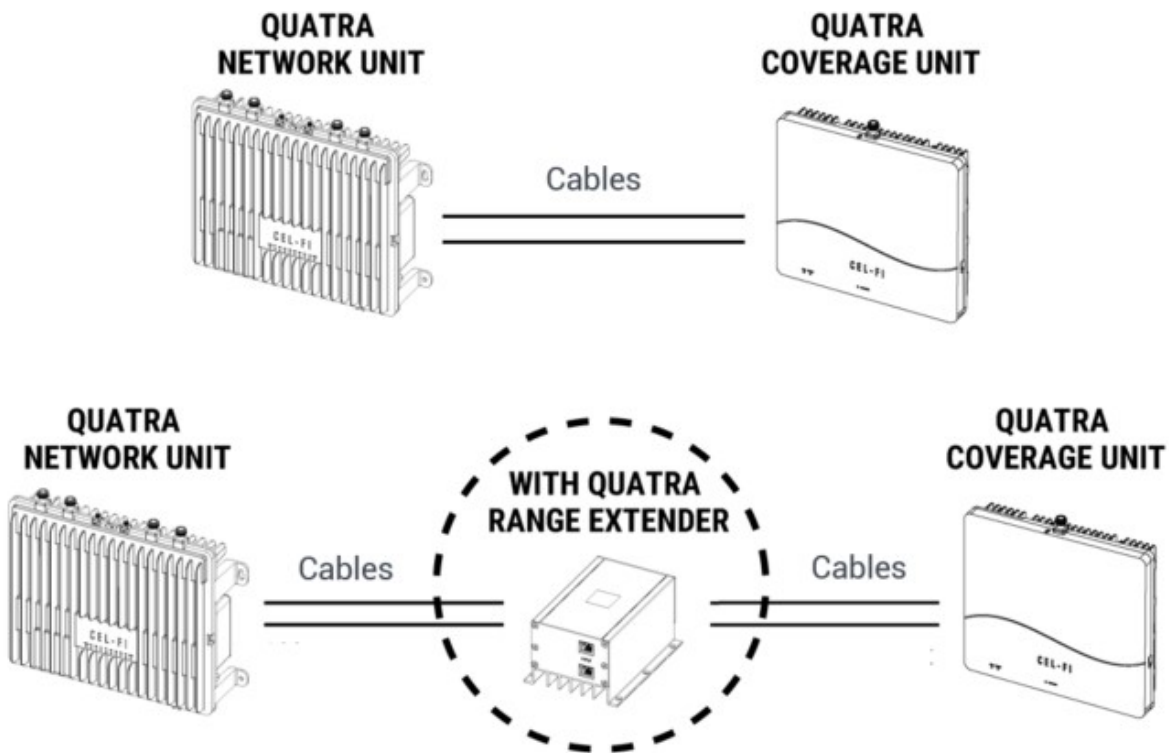

If even longer CU cables are required, use the QUATRA Fiber QRE for up to an additional 2km of cable length.

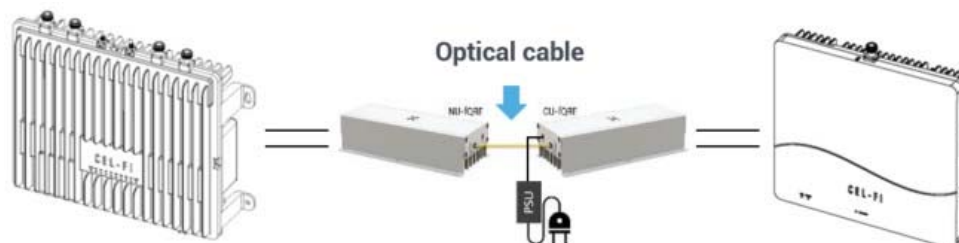

Note: Only the QUATRA 4000 RANGE EXTENDER (QRE-4K) may be used. The QUATRA 1000 and QUATRA 2000 QRE is not compatible with the QUATRA 4000c.

LEDs

NU

The QUATRA 4000c NU has ten (10) LEDs on the front of the unit, used as status indicators, during setup and normal operation. The LEDs are labeled.

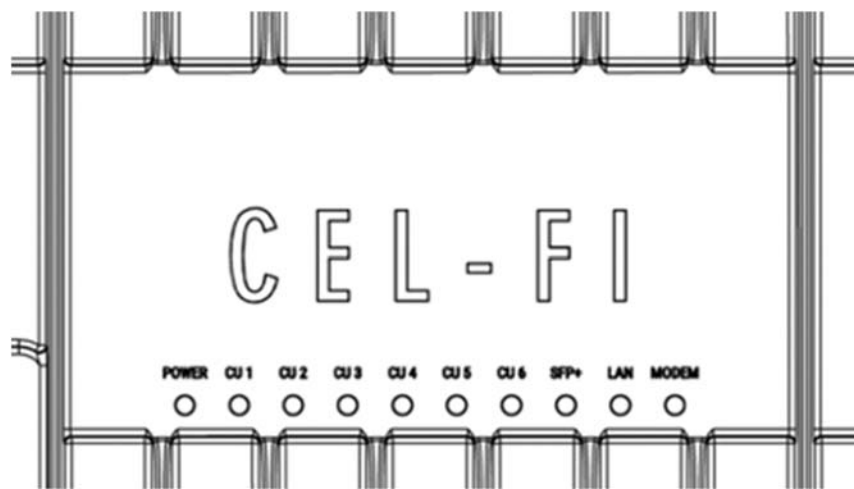

NU LEDs

The LEDs on the front of the QUATRA 4000c function as follows:

LED Label	LED State	Meaning
POWER	NO LIGHT	No power
	SOLID GREEN	Powered and operating normally
	FLASHING GREEN	Scanning to acquire network signals
	SOLID RED	Hardware error
	FLASHING RED	Error
CU1, CU2, CU3, CU4, CU5, CU6	NO LIGHT	Not connected properly, no power
	SOLID GREEN	Connected, powered and operating normally
SFP+	SOLID GREEN	SFP+ module installed, and communicating properly
	FLASHING GREEN	SFP+ module installed, not communicating
LAN	SOLID GREEN	Link is up

	FLASHING GREEN	Link is up and active
MODEM	SOLID GREEN	Modem is installed, connected, and has an IP address
	FLASHING GREEN	Modem is attempting to connect
	FLASHING RED-GREEN	Modem is functioning properly

CU

Each QUATRA 4000c CU has three (3) LEDs on the front of the unit, used as status indicators, during setup and normal operation. The LEDs are labeled.

C E L - F I

PWR NU LINK
○ ○

○ CABLE LINK

CU LEDs

The meaning for each LED on the CU is shown in the table below.

LED Label	LED State	Meaning
POWER	NO LIGHT	No power
	SOLID GREEN	Powered and operating normally
	FLASHING GREEN	Network scanning
	SOLID RED	Hardware error
NU LINK	FLASHING RED	Error
	NO LIGHT	Logical Link: Down
CABLE LINK	SOLID GREEN	Logical Link: Up
	NO LIGHT	Physical Link: Down
	SOLID GREEN	Physical Link: Up

Commissioning and the WAVE Portal

The full functionality of the WAVE Portal goes beyond the scope of this user guide, however it is an integral component of any install. It is accessible using your internet browser.

Each cloud connected system checks in once an hour so performance is trackable over time. Real time data is transmitted from systems currently being viewed. Some of the portal features are as follows:

- Installation Map (global)
- Statistics and alarms
- Notifications (alarms, texts, email)
- Installation Site details
- Detailed system performance information
- Settings and control
- Software updates
- Remote diagnostics
- Automated analysis and guidance with improvement suggestions for each install
- Floorplan coverage grid test interface for the COMPASS XR (Cellular and Public Safety)
- Grid test automated report generation
- Cloud storage for your site documentation

The purpose of the portal is to save you time and money, and to help you realize maximum performance from each system you install. If you do not already have portal access, you may request it on our Support page:

<https://www.cel-fi.com/support/>

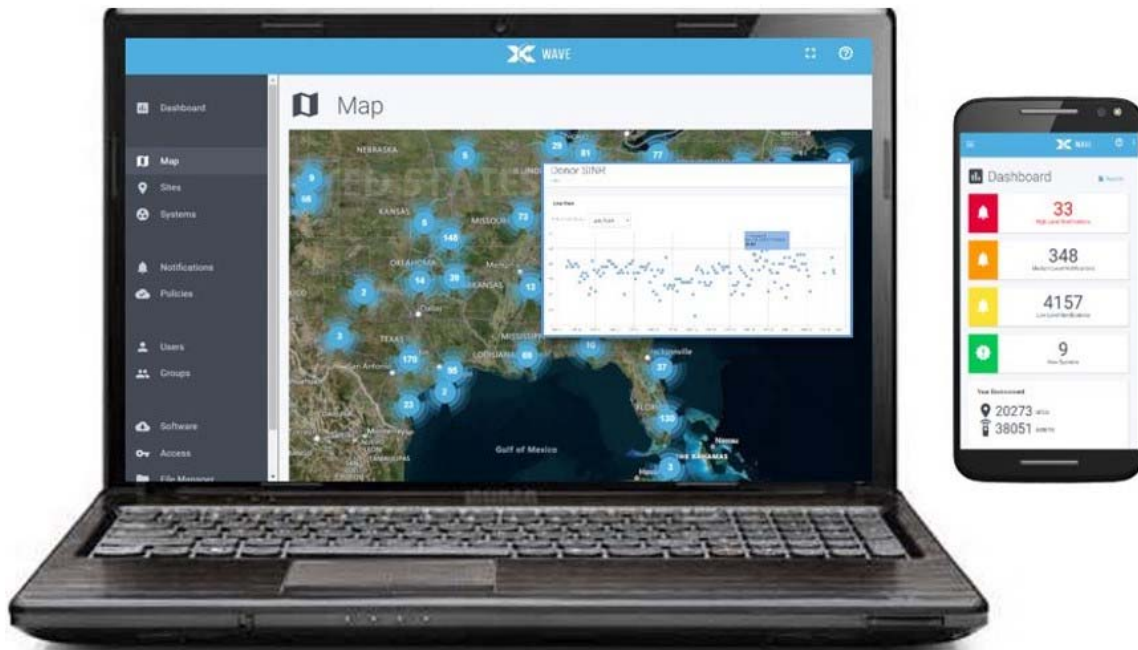

Diagnostics and Testing

WAVE PRO and COMPASS XR

COMPASS XR is a hand-held battery operated device specifically designed to simplify the installation of NEXTIVITY systems, The WAVE PRO app connects to and controls COMPASS over Bluetooth.

COMPASS and the WAVE PRO App



COMPASS XR and the WAVE PRO app have many useful features, including:

- Donor Antenna Aiming
- Full Cellular band scans for 4G and 5G, plus Public Safety 700/800 bands
- Grid Testing
- System Configuration, Settings and Diagnostics (Nextivity Public Safety systems)

WAVE Field Tool

The WAVE Field Tool runs on Windows 10 or higher, and has many useful tools such as:

- Cloud Connection test (NU to the WAVE Portal)
- SIM card maintenance
- DHCP/Static IP Settings
- Factory reset
- Cloud Reset
- Full system software update/reload



For more information about COMPASS XR, the WAVE Field Tool, or other useful tools and resources, please contact your point of sale or Nextivity at www.cel-fi.com

Antenna Kitting

The QUATRA 4000c is designed to be used with the following antennas.

Donor Antennas

1. LPDA-R Antenna

Model Number: A62-V44-201 <https://cel-fi.com/antennas/lpda-r-antenna/>

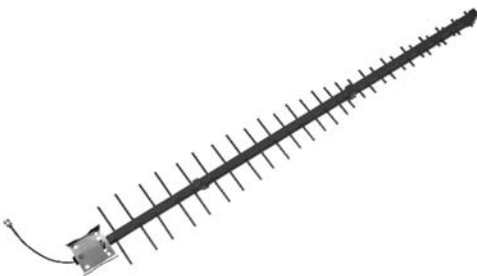

The Cel-Fi LPDA-R Antenna offers a powerful 12 to 14 dBi gain (depending on carrier frequency) over 617–4000 MHz and is designed to reduce out of band noise, to improve SiNR and overall signal quality. Mounting is made simple with included U-Bolts. This Cel-Fi product also features a 10K ohm resistor that enables the antenna connection to be validated by Cel-Fi Network Units equipped with the capability.

- 12–14 dBi gain
- 5G-ready
- Narrow beam-width to reduce noise

- Rugged construction for harsh environments
- Includes a 10K ohm resistor for special Cel-Fi applications

3. Cel-Fi Wideband Directional Antenna

Model Number: A32-V32-201



The Cel-Fi Wideband Directional Antenna is an outdoor vertically polarized highly directional antenna for Cellular Boosters; with 10 dB gain in the low bands and 11 dB gain in the high bands. The weather resistant housing is built with UV stabilized ABS plastic casing. Optimized for Cel-Fi products, the Cel-Fi Wideband Directional Antenna works great with the Cel-Fi WAVE Antenna positioning app. The unit includes standard brackets for mounting, and can also be used with the Cel-Fi Pole Mount.

- Outdoor/Indoor use
- Boosts Cell Signal by up to 11 dBi
- 5G-ready
- 700 – 2700 MHz Frequency
- Vertical Polarization
- Directional

Server Antennas

1. Indoor Omni Dome Antenna

Model Number: A11-V43-121



The Indoor Omni Antenna receives and transmits signal in a 360° pattern and are compatible with the 698 - 2700 MHz frequency ranges that include 3G and 4G signals. They come with an SMA Male Connector.

- Indoor use
- 5G ready
- 50 ohm
- 698 - 2700 MHz
- N-Female connector
- Omni-directional

Note: -101 part number includes an N-type connector

2. (Low-Profile) LP SISO Indoor Omni Antenna

Model Number: [A11-H43-201](#)



Nextivity's Cel-Fi LP SISO Indoor Omni Antenna provides a 360-degree horizontal coverage pattern in an ultra-modern, low-profile, high performance industrial design.

- Indoor use
- 5G-ready
- 50 ohm
- 617–4000 MHz
- N-type connector (other options available)
- Ultra low-profile

Donor Antennas

Antenna Kitting Section

In order to comply with FCC/ISED RF Exposure requirements:

1. The donor antenna must be installed to provide at least 65 cm separation from the human body at all times.
2. The server antenna must be installed to provide at least 20 cm separation from the human body at all times.

Antenna systems to be used with Quatra 4000C are limited per table below:

Port	Max System (Antenna & Cable) Gain
CU	0.01 dBi for WCDMA Band 5 1.16 dBi for LTE Band 4 1.44 dBi for LTE Band 12 1.16 dBi for LTE Band 13 0.14 dBi for LTE Band 25 1.85 dBi for LTE Band 30 9.46 dBi for LTE Band 48 0.68 dBi for LTE Band 71
NU Port 1	8.32 dBi for WCDMA Band 5 6.63 dBi for LTE Band 4 8.08 dBi for LTE Band 12 6.52 dBi for LTE Band 25 8.49 dBi for LTE Band 30
NU Port 2	6.63 dBi for LTE Band 4 8.08 dBi for LTE Band 12 6.52 dBi for LTE Band 25 6.06 dBi for LTE Band 71
NU Port 3	6.63 dBi for LTE Band 4 7.99 dBi for LTE Band 13 6.52 dBi for LTE Band 25
NU Port 4	4.13 dBi (This port only supports LTE B48)

Donor Signals

A good donor signal, arriving as cleanly as possible, to the NU, is perhaps the most important consideration in driving the best experiences and outcomes with QUATRA 4000c.

With regard to 4G or 5G, there are two metrics of particular importance to monitor and optimize:

1. RSRP. Reference Signal Receive Power. It is the power of the LTE Reference Signals spread over the full bandwidth and narrowband. A minimum of -20 dB SINR (of the S-Synch channel) is needed to detect RSRP/RSRQ.

In the context of Cel-Fi QUATRA 4000c, the following stratification of quality is recognized:

RSRP	Signal Strength
> -90 dBm	Excellent
-90 dBm to -105 dBm	Good
-106 dBm to -120 dBm	Fair
< -120 dBm	Poor

2. SINR. Signal to Noise Ratio. The SINR is the ratio of the usable (desired) signal over the noise. The following metrics should be used when assessing SINR in the context of Cel-Fi QUATRA 4000c.

SINR Value	Throughput
> 10	Excellent
6 to 10	Good
0 to 5	Fair
< 0	Poor

Antenna Selection

There are a few considerations to make when determining the donor antenna.

1. How many serving sites? If there are multiple serving sites, and the design goal is to select a specific site, for loading, or any other reason, then directional antenna would be required. If there is a single donor site, and not much RF contention, than an omni-directional antenna could be considered, which would save a little time and energy in the install process, as it would not need to be aimed.
2. How much noise? If the site location is very noisy, then a strong directional antenna would be a good choice, as it will filter out some of the unwanted noise and improve SINR.
3. How strong is the serving signal? Although Cel-Fi QUATRA 4000c has the highest gain of any system in its class, if the serving signal is extremely weak, then a high-gain antenna may be required to connect the uplink calls and to get the optimal DL power on the serving side.

Grounding and Lightning Protection

Installers of Cel-Fi QUATRA 4000c are encouraged to follow the lightning protection guidelines documented in the National Electrical Code (NEC) and NFPA 780, and/or local codes.

Server Antennas

The QUATRA 4000c Coverage Unit has a single RF output port in the form of an N-type female connector on the top of the unit. A single whip or blade-style antenna can be attached directly, or a distributed antenna system can be deployed.

Antenna Selection

There are two types of indoor antenna to choose from:

Omni-directional dome antennas broadcast and receive signals from all sides. They are designed for central locations with 360° coverage requirement. Like outdoor antennas, their power is measured by their “gain”. They are typically mounted to a ceiling for best results.

Nextivity has standard dome antennas and also offers ‘low-profile’ server antennas that are thin and occupy less visual space.

Panel antennas are directional antennas. Panel antennas allow optimum reception to targeted areas. Like with outdoor antennas, a directional antenna is stronger than an omnidirectional antenna which means the signals it broadcasts are stronger in a particular direction. It can be mounted to either the wall or ceiling. We usually recommend placing it on the ceiling for maximum coverage but in some spaces (like a long narrow hallway) the panel antenna can be placed on a wall.

Nextivity has a few different panel antenna options, with different levels of gain and directivity.

Mounting (Coverage Unit)

Drop Ceiling

The QUATRA 4000c Coverage Unit is fitted with two ¼”-20 inserts in the center of the bottom side of the unit. This is designed to mate perfectly with standard drop-ceiling infrastructure components. The mounting bracket also has four (4) ¼”-20 threaded inserts which can be similarly used. A variety of mounting methods can be employed through the integration of off-the-shelf accessories.

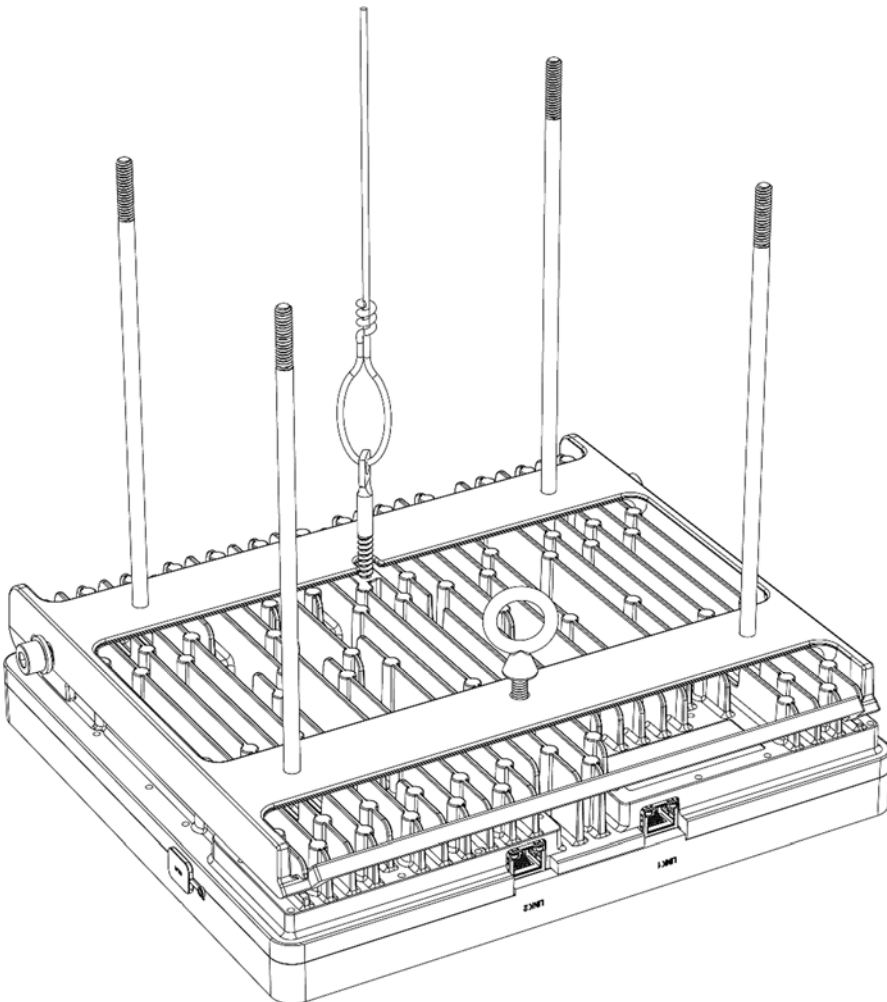

Note: The Cel-Fi QUATRA 4000c Coverage Unit is plenum rated.

Specifications

For details, please refer to the [Cel-Fi QUATRA 4000c Data Sheet](#)

Trademarks

Cel-Fi, IntelliBoost, and Nextivity logo are trademarks of Nextivity, Inc.

Warranty & Limitation of Liability

Nextivity Inc., provides a limited warranty for its products.

For details, please refer to cel-fi.com/warranty.

In no event shall Nextivity, nor its directors, employees, agents, suppliers or End Users, be liable under contract, tort, strict liability, negligence or any other legal or equitable theory with respect to the Products or any other subject matter of this Agreement (i) for any lost profit, cost of procurement of substitute goods or services, or special, indirect, incidental, punitive, or consequential damages of any kind whatsoever or (ii) for any direct damages in excess of (in the aggregate) the fees actually received by Nextivity from End User with respect to the Products actually purchased and paid for.

Compliance

In the event of regulatory compliance issue, please contact Nextivity Inc. directly.

Contact information is available at cel-fi.com/doc

Glossary

Term	Definition
MIMO	Multiple In, Multiple Out
SISO	Single In, Single Out
SiNR	Single to Noise ratio
RSRP	Reference Signal Receive Power
RSSI	Received Signal Strength Indicator
Donor Antenna	Antenna used to capture the exterior macro cellular network signal, and provide such signal to the system.
Server Antenna	Antenna used internally to provide the coverage benefit from Cel-Fi QUATRA 4000c.

Troubleshooting

Alarm Error	Description
Network Unit Hardware Error	Power cycle the Network Unit (NU) and check for software updates. If problem persists, return NU for service.
Insufficient Donor Signal	Relocate Network Unit (NU) where a stronger signal exists, or use an external antenna for the NU. If using a small cell, verify the small cell can process calls and check the connections to the NU. Power cycle the NU.
Coverage Unit Hardware Error	Troubleshoot any Network Unit (NU) error first, and check for software updates. Make sure Coverage Unit (CU) cables do not exceed recommended cable length maximums. Note that standard Ethernet Extenders or active LAN switches and routers will not work with CU cabling. Power cycle the CU by detaching and reattaching the LAN cable. Test CU by plugging it into back of NU with short test cable.
Donor Signal Too Strong	Move Network Unit (NU), or re-aim NU external antenna. Strong signal source may be from another Operator's device (cell tower, local small cell, or booster).
Network Unit is Overheating	The Network Unit (NU) should be upright and the air vents not blocked. Move NU to a cooler area.

Coverage Unit is Overheating	Make sure the Coverage Unit (CU) air vents are not blocked, or move the CU to a cooler location.
Too Close	One of your Coverage Units (CU) is too close to your Network Unit (NU). Try moving the units farther apart (or move units so more signal blocking structures isolate them from each other).
Too Far	One of your Coverage Units (CU) is too far from your Network Unit (NU). Try moving the units closer together.
Disabled by Operator/Vendor	Your system has been disabled by the mobile network operator or vendor. Contact your vendor for further assistance.
Location Lock	Your system has been moved from its original address. Please move the system back to its original location or register your new address with your wireless provider.
Registration Required	Systems are pre-enabled and carrier registration is obligatory.
Self-Test Failed	Power cycle the unit and check for software updates. If problem persists, return the unit for service.
Small Cell Not Detected	Network Unit (NU) Mode is set to small cell. Verify that small cell is connected and operational, or set NU Mode to Internal or External Antenna if no Small Cell used.
Small Cell Detected	Small Cell Detected but Network Unit (NU) is not set to Small Cell. Use the WAVE Portal to set NU Mode to Small Cell.
Antenna Configuration Error	Too Many Coverage Units (CU) connected. More than one CU in use for Off-Air configuration. Use the WAVE Portal to set Mode to External Antenna, and NU should be connected to an external antenna.
Antenna Positioning Required	Antenna positioning incomplete. Use the WAVE Portal to aim the NU donor antenna.
Ethernet Link Error	The ethernet link between NU and CU is behaving unreliably or reporting an error. Ensure the ethernet cable is not damaged and its connectors are securely plugged in on both ends.
CU Shutdown from Portal	CU's 1 though 4 has been shut down from the Portal.