



Report On

Application for Grant of Equipment Authorization of the
Nextivity Inc.
Cel-Fi GO Cellphone Signal Repeater

FCC CFR 47 Part 20
RSS-131

Report No. SD72121023-1016G

March 2017





REPORT ON Radio Testing of the
Nextivity Inc.
Cellphone Signal Repeater

TEST REPORT NUMBER SD72121023-1016G

PREPARED FOR Nextivity Inc.
16550 West Bernardo Drive, Bldg 5, Suite 550,
San Diego, CA 92127, USA

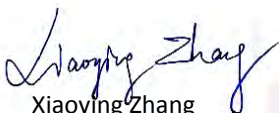
CONTACT PERSON CK Li
Sr. Principal Engineer, Regulatory
(858) 485-9442
CLi@NextivityInc.com

PREPARED BY 
Xiaoying Zhang
Name
Authorized Signatory
Title: EMC/Wireless Test Engineer

APPROVED BY 
Juan M. Gonzalez
Name
Authorized Signatory
Title: EMC SL Manager Western Region

DATED March 15, 2017



Revision History

SD72121023-1016G Nextivity Inc. Cel-Fi GO Cellphone Signal Repeater					
DATE	OLD REVISION	NEW REVISION	REASON	PAGES AFFECTED	APPROVED BY
03/15/17	Initial Release				Juan M Gonzalez



CONTENTS

Section	Page No
1	REPORT SUMMARY 5
1.1	Introduction 6
1.2	Brief Summary of Results 7
1.3	Product Information 8
1.4	EUT Test Configuration 11
1.5	Deviations from the Standard 17
1.6	Modification Record 17
1.7	Test Methodology 17
1.8	Test Facility Location 17
1.9	Test Facility Registration 17
2	TEST DETAILS 19
2.1	Authorized Frequency Band Verification 20
2.2	Authorized CMRS Provider 29
2.3	Authorized CMRS Provider Spectrum for Mobile Devices 59
2.4	Maximum Power Measurement and Booster Gain Computation 69
2.5	Intermodulation Product 75
2.6	Out of Band Emissions 91
2.7	Noise Limit 120
2.8	Uplink Inactivity 128
2.9	Variable Booster Gain 134
2.10	Oscillation Detection 150
2.11	Mobile Booster Automatic Feedback Cancellation 161
2.12	Out of Band Gain Limit 163
3	TEST EQUIPMENT USED 172
3.1	Test Equipment Used 173
3.2	Measurement Uncertainty 174
4	DIAGRAM OF TEST SETUP 175
4.1	Test Setup Diagram 176
5	ACCREDITATION, DISCLAIMERS AND COPYRIGHT 177
5.1	Accreditation, Disclaimers and Copyright 178



SECTION 1

REPORT SUMMARY

Radio Testing of the
Nextivity Inc.
Cel-Fi GO Cellphone Signal Repeater



1.1 INTRODUCTION

The information contained in this report is intended to show verification of the Nextivity Inc. Cellphone Signal Repeater to the requirements of the following:

- FCC CFR 47 Part 20
- RSS-131

Objective	To perform Radio Testing to determine the Equipment Under Test's (EUT's) compliance with the Test Specification, for the series of tests carried out.
Manufacturer	Nextivity Inc.
Model Name	Cel-Fi GO
Model Number(s)	G32-2/4/5/12/13
FCC ID	YETG32-2451213
IC Number	9298A-G322451213
Serial Number(s)	332633000356, 332633000271, 932703000264, 932703000073 (Fix Unit) 332633000417, 932703000165, 932703000059 (Mobile Unit)
Number of Samples Tested	7
Test Specification/Issue/Date	<ul style="list-style-type: none">• FCC CRF 47 Part 20 (October 1, 2016).• RSS-131 – Zone Enhancers (Issue 3, January 2016)• KDB935210 (D04 Provider Specific booster Measurements v02) Provider-Specific Consumer Signal Booster Compliance Measurements Guidance.
Start of Test	December 22, 2016
Finish of Test	March 08, 2017
Name of Engineer(s)	Xiaoying Zhang
Related Document(s)	<ul style="list-style-type: none">• Supporting documents for EUT certification are separate exhibits.

1.2 BRIEF SUMMARY OF RESULTS

A brief summary of the tests carried out in accordance with FCC CFR 47 Part 20 with cross-reference to the corresponding KDB935210 D04 is shown below.

Section	Spec Clause			Test Description	Result
	FCC Part 20	KDB935210 D04	RSS-131		
2.1 2.2 2.3	20.21 (e)(3) Frequency Bands 20.21 (e)(4) Self-Monitoring	7.1	-	Authorized Frequency Band Verification Test Authorized CMRS provider test Authorized CMRS provider spectrum for mobile devices	Compliant
2.4	20.21(e)(9)(i)(D) Power Limits 20.21(e)(9)(i)(B) Bidirectional Capability 20.21(e)(9)(i)(C)(1) and (2) Booster Gain Limits	7.2 7.3	4.1	Maximum Power measurement procedure Maximum Booster Gain Computer	Compliant
2.5	20.21(e)(9)(i)(G) Intermodulation Limit	7.4	-	Intermodulation Product	Compliant
2.6	20.21(e)(9)(i)(F) Out of Band Gain Limit	7.5	-	Out-of-Band Emissions	Compliant
-	2.1051	7.6	-	Conducted Spurious Emissions	N/A*
2.7	20.21(e)(9)(i)(A) Noise Limits 20.21(e)(9)(i)(I) Transmit Power Off Mode	7.7	-	Noise Limits	Compliant
2.8	20.21(e)(9)(i)(J) Uplink Inactivity	7.8	-	Uplink inactivity	Compliant
2.9	20.21(e)(9)(i)(C)(1) Booster Gain Limits 20.21(e)(9)(i)(I) Transmit Power Off Mode	7.9	4.2	Variable Booster Gain	Compliant
-	2.1049	7.10	-	Occupied Bandwidth	N/A*
2.10	20.21(e)(9)(ii)(A) Anti-Oscillation	7.11	-	Oscillation Detection	Compliant
2.11	20.21(e)(9)(i)(C)(2)(iii) Automatic Feedback Cancellation	7.12	-	Mobile Booster Automatic Feedback Cancellation	Compliant
-	2.1053	7.13	-	Radiated Spurious Emissions	N/A*
-	20.21(e)(9)(i)(B) Bidirectional Capability 20.21(e)(3) Frequency Band	7.14	-	Spectrum Block Filtering	N/A**
2.12	20.21(e)(9)(i)(E) Out of Band Gain Limit	7.15	-	Out of Band Gain	Compliant
-	2.1055	7.16	-	Frequency Stability	N/A*

N/A* - Not Applicable. Different Standard Applies; Refer to test report SD72121023-1016C for WCDMA/LTE Band 2 and Band 5, SD72121023-1016D for LTE Band 13, SD72121023-1016E for LTE Band 12 and SD72121023-1016F for LTE Band 4.

N/A** - Not Applicable. The EUT does not utilize spectrum block filtering.

1.3 PRODUCT INFORMATION

1.3.1 Technical Description

The Equipment Under Test (EUT) is a Nextivity Inc. Cel-Fi GO Cellphone Signal Repeater. The EUT is a WCDMA/LTE Signal Booster to improve voice and data cellular performance in a variety of mobile (e.g. Vehicle and Marine), Fix (e.g. Home/office and Nomadic), Indoor and Outdoor environments. Both Fix and Mobile Versions are identical except the allowed maximum system gains which are set by firmware during production. The model tested in this report was the Fix sample as the representative unit unless otherwise stated. The unit includes Bluetooth LE connectivity. With the use of Nextivity smartphone application, it allows user to register the product, update software, capture / display details metrics of the system. The WCDMA Band 2, 5 and LTE Band 2, 5, 12, 13 and 4 function of the EUT were verified in this test report.

1.3.2 EUT General Description

EUT Description	Cellphone Signal Repeater
Model Name	Cel-Fi GO
Model Number(s)	G32-2/4/5/12/13
Rated Voltage	15V DC via external AC/DC adapter (Fix Unit) 12V DC via CLA (Cigarette Lighter Adaptor) (Mobile Unit)
Mode Verified	WCDMA Band 2, 5 and LTE Band 2, 5, 12, 13, and 4
Frequency Bands	WCDMA/LTE Band 2: UL: 1850 - 1910MHz DL: 1930 - 1990MHz WCDMA/LTE Band 5: UL: 824 - 849MHz DL: 869 - 894MHz LTE Band 12: UL: 699 - 716MHz DL: 729 - 746MHz LTE Band 13: UL: 777 - 787MHz DL: 746 - 756MHz LTE Band 4: UL: 1710 - 1755MHz DL: 2110 - 2155MHz
Channel Bandwidth	WCDMA Band 2: 5MHz,10MHz (2C), 15MHz (3C) and 20MHz (4C) WCDMA Band 5: 5MHz, 10MHz (2C) and 15MHz (3C) LTE Band 2: 5MHz, 10MHz, 15MHz and 20MHz LTE Bandn 5: 5MHz, 10MHz and 15MHz LTE Band 12: 5MHz, 10MHz LTE Ban 13: 5MHz, 10MHz LTE Band 4: 5MHz, 10MHz, 15MHz and 20MHz
Capability	WCDMA (Band 2 and 5), LTE (Band 2, 5, 12, 13 and 4) and BT LE
Primary Unit (EUT)	<input type="checkbox"/> Production <input type="checkbox"/> Pre-Production <input checked="" type="checkbox"/> Engineering
Manufacturer Declared Temperature Range	0°C to 65°C

Antenna Type	External Antenna
Manufacturer	N/A
Antenna Model	N/A
Maximum Antenna Gain	N/A (Supplied by customer)

1.4 EUT TEST CONFIGURATION

1.4.1 Test Configuration Description

Test Configuration	Description
A	Test Mode - Downlink (CU TX). Input signal is applied to antenna port of Donor (NU). Output is monitored from antenna port of Server (CU). (refer to 6.3.3 Figure 2)
B	Test Mode - Uplink (NU TX). Input signal is applied to antenna port of Server (CU). Output is monitored from antenna port of Donor (NU). (refer to 6.3.3 Figure 3)
C	Normal Mode - Downlink (CU TX). Base Station Simulator is employed to send a modulated signal to antenna port of Donor (NU). Antenna port of Server (CU) is terminated with a 50Ω load. (refer to 6.3.2 Figure 1)
D	Normal Mode - Uplink (NU TX). Base Station Simulator is employed to send a modulated signal to antenna port of Donor (NU). Input signal is applied to antenna port of Server (CU). (refer to 6.3.2 Figure 1)
E	Normal Mode. Base Station Simulator#1 is employed to send a modulated signal to antenna port of Donor (NU) with Simulator#2 connected to a step attenuator and then applied to the Donor (NU) through a combiner. Input signal is applied to antenna port of Server (CU) (refer to 7.1.3 Figure 4)
F	Inter-modulation. Test setup identical to Test Configuration A and B above with the addition of another signal applied to the input of the EUT. A coupler was used in the setup to ensure that the additional signal is directed to the EUT input port. (refer to 7.4 Figure 5)
G	Max Downlink noise limit testing - A 50 Ohm Termination is connected to the Donor (NU) antenna port and Measure the Noise Limit at the Server (CU) antenna port. (refer to 7.7.1 Figure 6)
H	Max Uplink noise limit testing - A 50 Ohm Termination is connected to the Server (CU) antenna port. A signal generator is connected to a step attenuator and then applied to the Donor (NU) antenna port. Output is monitored from antenna port of Donor (NU). (refer to 7.7.1 Figure 7)
I	Max Downlink noise limit testing - A signal generator is connected to a step attenuator and then applied to the Donor (NU) antenna port. Output is monitored from antenna port of CU. (refer to 7.7.1 Figure 8)
J	Uplink Oscillation Detection testing - Base Station Simulator is connected to a step attenuator and then applied to the Donor (NU) antenna port and a signal generator is connected to the Server (CU) port. A Feedback Step Attenuator is connected between the Donor (NU) and Server (CU) antenna ports. Output is monitored from antenna port of Donor (NU). (refer to 7.11 Figure 10)
K	Downlink Oscillation Detection testing - Base Station Simulator is connected to a step attenuator and then applied to the Donor (NU) antenna port and a signal generator is connected to the Server (CU) port. A Feedback Step Attenuator is connected between the Donor (NU) and Server (CU) antenna ports. Output is monitored from antenna port of Server (CU). (refer to 7.11 Figure 11)
L	Downlink/Uplink Oscillation Mitigation testing – Signal Generator is connected to a directional coupler and then applied to the Donor (NU)/Server (CU) antenna port of Fix Unit and a spectrum analyser is connected to the Server (CU)/Donor (NU) port. A Feedback Step Attenuator is connected between the Donor (NU) and Server (CU) antenna ports. (refer to 7.11 Figure 12)

M	Downlink/Uplink Mobile Booster Automatic Feedback Cancellation – Signal Generator is connected to a directional coupler and then applied to the Donor (NU)/Server (CU) antenna port of Mobile Unit and a spectrum analyser is connected to the Server (CU)/Donor (NU) port. A Feedback Step Attenuator is connected between the Donor (NU) and Server (CU) antenna ports. (refer to 7.12 Figure 13)
---	---

1.4.2 EUT Exercise Software

Manufacturer provided a configuration software (ConformanceTest.exe) running from a support laptop where EUT is connected via USB.

1.4.3 Support Equipment and I/O cables

Manufacturer	Equipment/Cable	Description
HON-KWANG	I.T.E Power Supply	Model: HK-AY-150A160-US S/N: GB0000007 Input: 100-240V, 50/60Hz, 0.8A; Output: 15 VDC 1.6A
-	Cigarette Lighter Adaptor (CLA)	Model: 290N035-001 Input: 12VDC; Output: 12VDC
Nextivity	Support USB cable	Custom 1.0 meter shielded USB Type A to Type A cable
Nextivity	USB / Interface Box	Unshielded with "Tag-Connect" interface
API Technologies Corp.	DC Block	M/N: 8037
Lenovo	Support Laptop	M/N: 2912-3VU, S/N: R9-92MH0 10/11
Lenovo	Support Laptop AC Adapter	M/N: 42T4430 S/N: 11S42T4430Z1ZGWE27AA9X
Rhode & Schwarz	Support Wideband Radio Communication Tester	M/N: CMW500, S/N: 1201.0002K50/103829
Agilent	ESG Vector Signal Generator	M/N: E4438C, S/N: MY47271033
Aeroflex international LTD.	DFS Radar Simulator and Analyzer*	M/N: Aeroflex 3005, S/N: 30050A/09L
Rhode & Schwarz	Feedback Attenuator	M/N: RSP, S/N: 834500/009
Agilent	11dB Step Attenuator	M/N 8494B Frequency Range DC - 18GHz S/N 2812A17193
Agilent	110dB Step Attenuator	M/N 8496B Frequency Range DC - 18GHz S/N MY42143874
Ramsey	Support Shielded Test Enclosure	With custom USB cable

1.4.4 Simplified Test Configuration Diagram

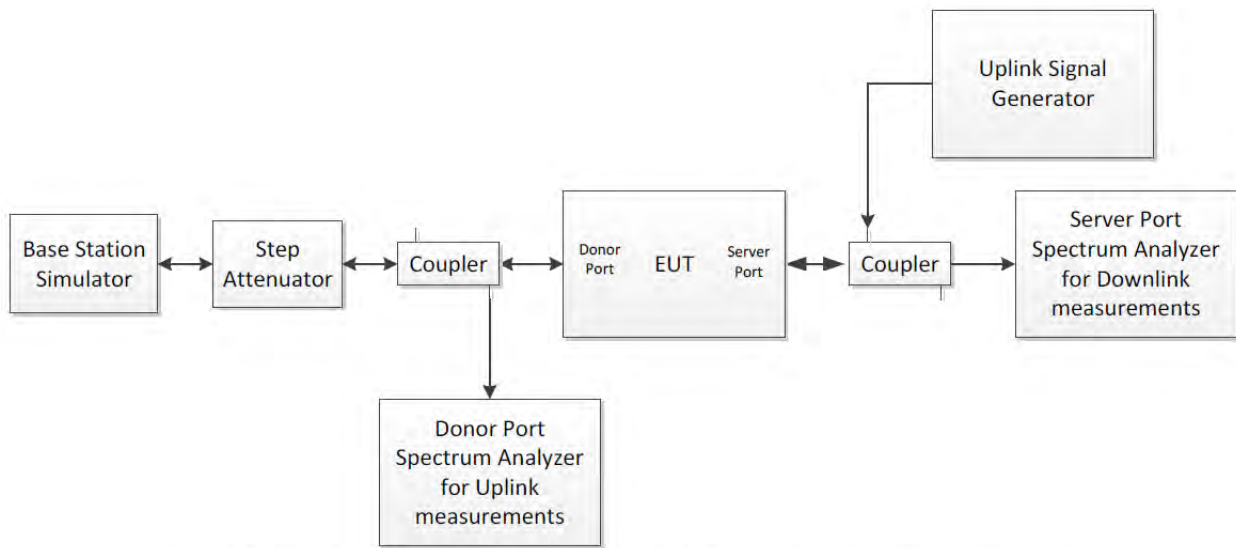

Figure 1 – Test configuration in EUT normal operational mode

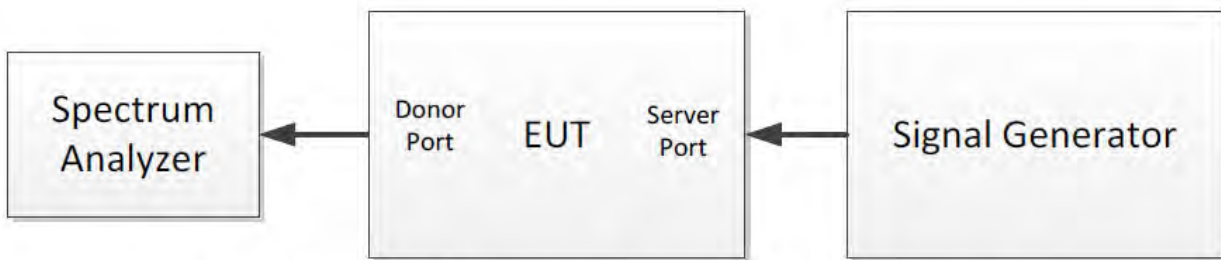

Figure 2 – Uplink test configuration in EUT test mode



Figure 3 – Downlink test configuration in EUT test mode

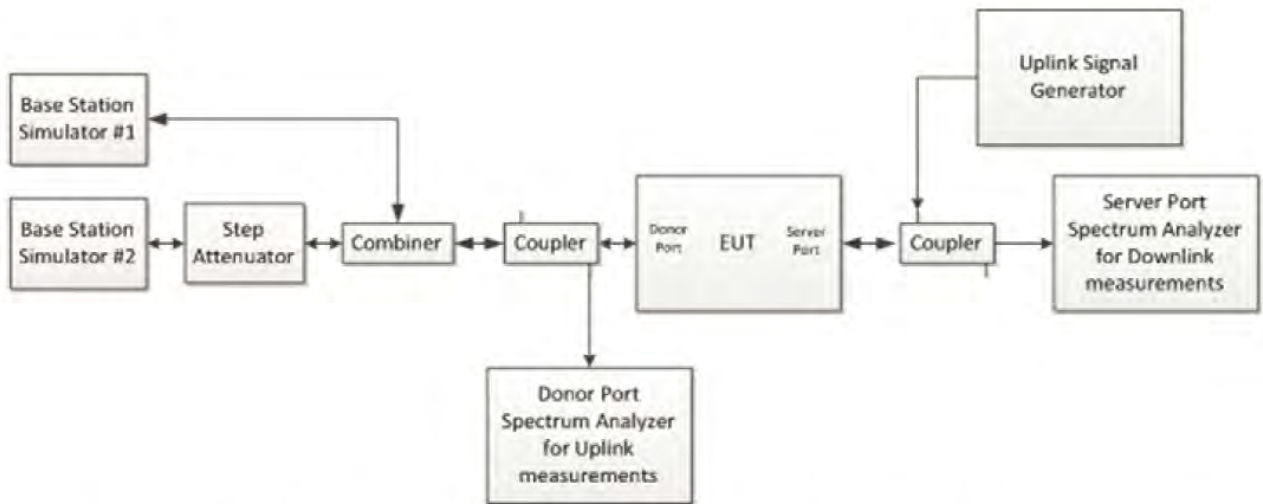

Figure 4 – Test set-up for authorized CMRS provider spectrum for mobile devices

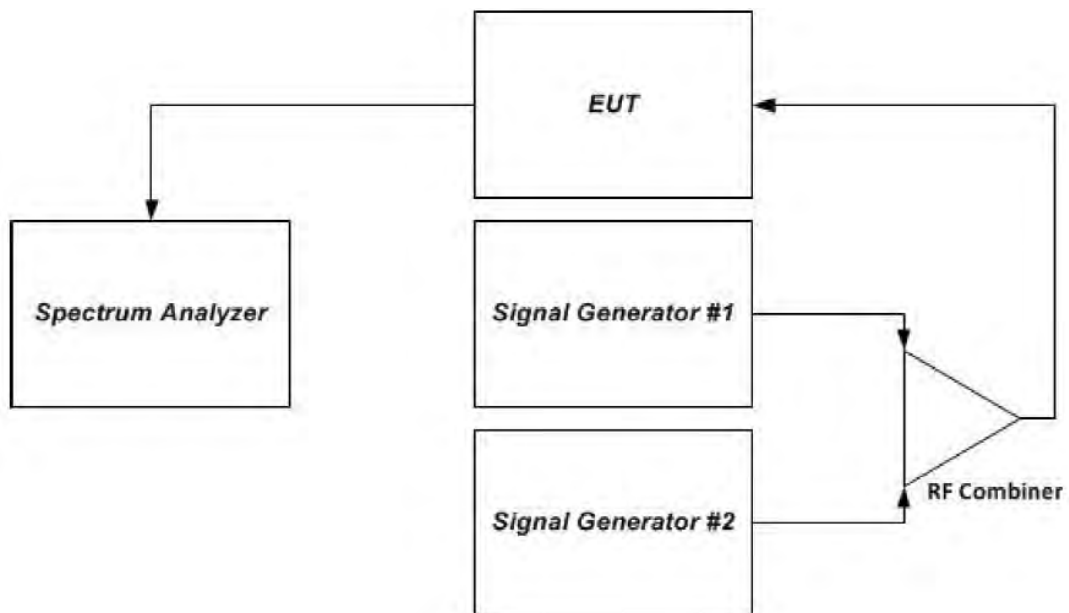

Figure 5 – Intermodulation product instrumentation test setup

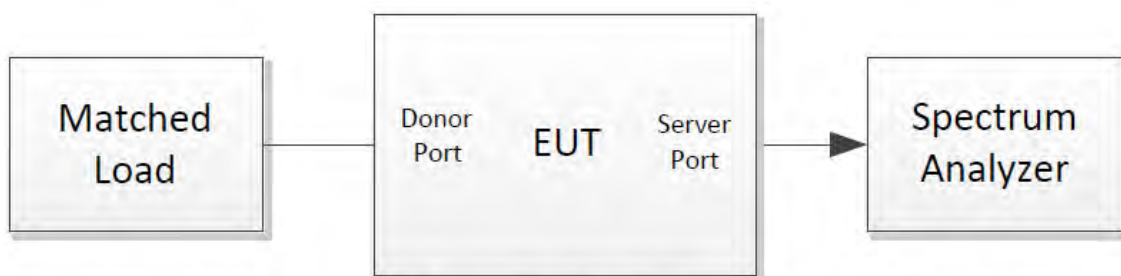

Figure 6|– Maximum downlink noise limit test configuration

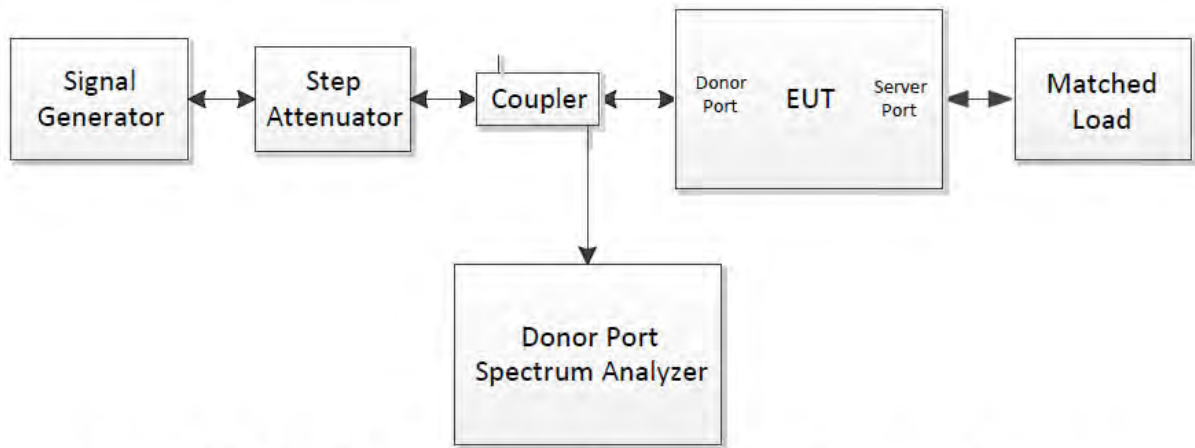

Figure 7 – Uplink RSSI-dependent noise limit test configuration

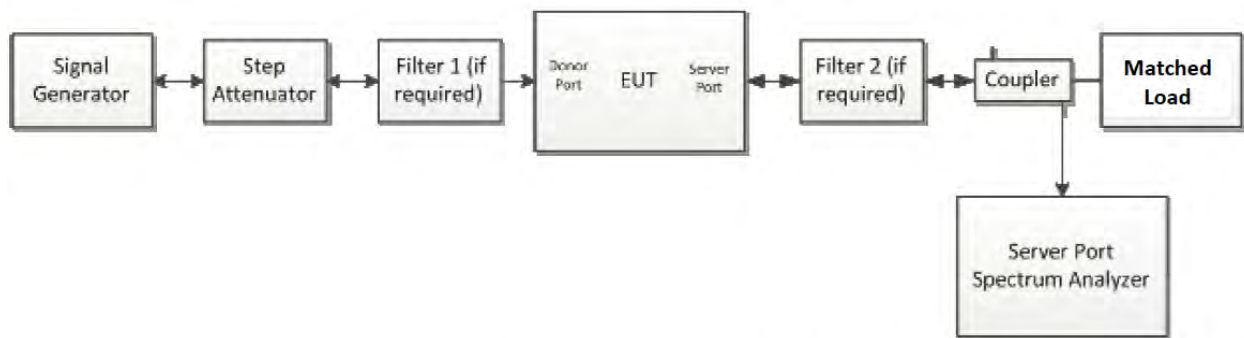

Figure 8 – Downlink RSSI-dependent noise limit test configuration

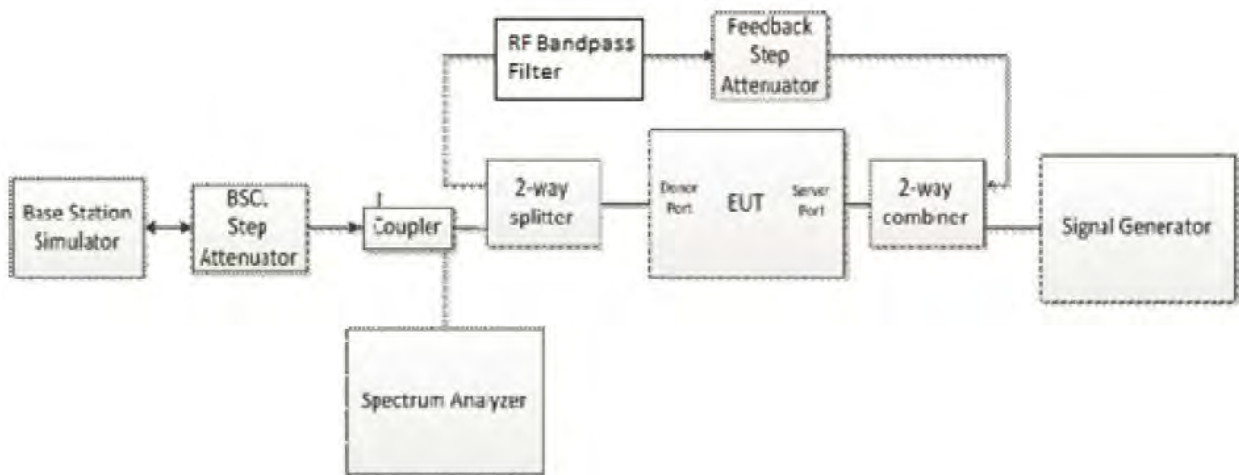

Figure 10 – Uplink oscillation detection test setup

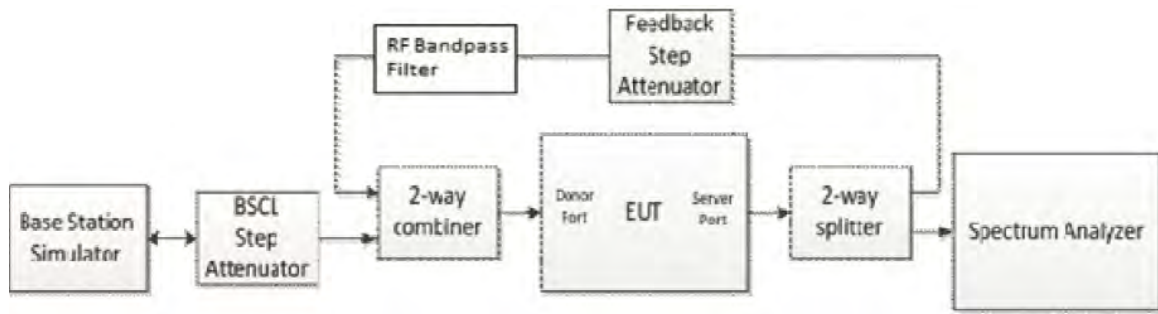

Figure 11 – Downlink oscillation detection test setup

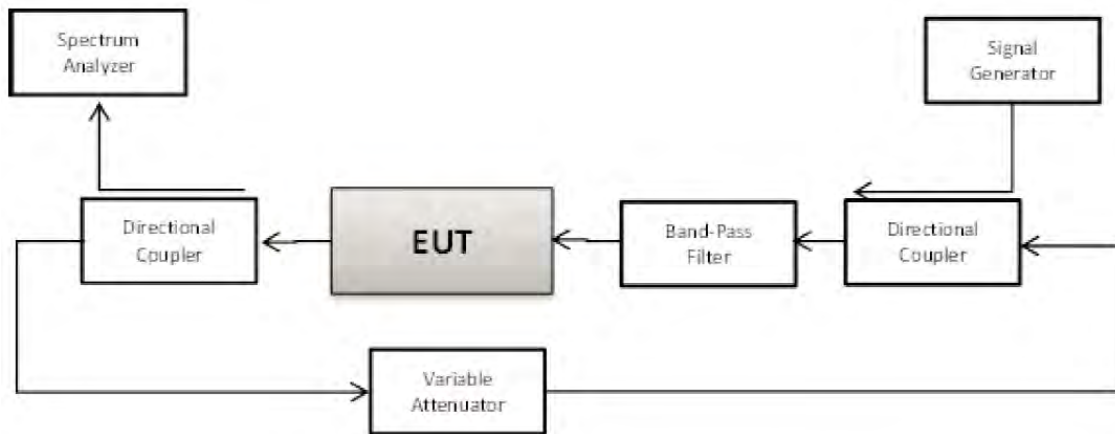

Figure 12 – Downlink oscillation mitigation test setup

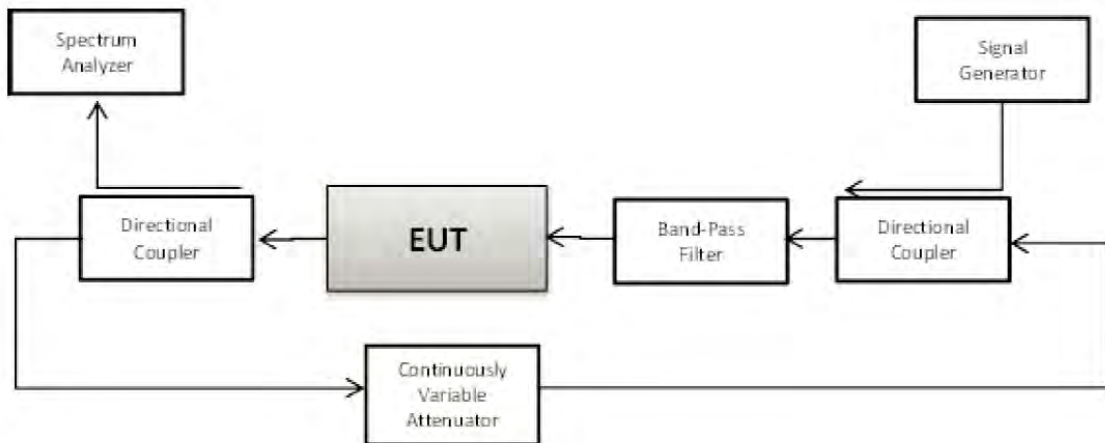

Figure 13 – Mobile booster automatic feedback cancellation test procedure

1.5 DEVIATIONS FROM THE STANDARD

No deviations from the applicable test standards or test plan were made during testing.

1.6 MODIFICATION RECORD

Description of Modification	Modification Fitted By	Date Modification Fitted
Serial Number: 332633000356, 332633000271, 932703000264, 932703000073 (Fix Unit); 332633000417, 932703000165, 932703000059 (Mobile Unit)		
Bias voltage for external antenna use was moved from server (CU) port to donor (NU) port and was changed from 12V to 3.3V.	CK Li	February 01, 2017

The table above details modifications made to the EUT during the test programme. The modifications incorporated during each test (if relevant) are recorded on the appropriate test pages.

1.7 TEST METHODOLOGY

All measurements contained in this report were conducted as per KDB935210 D04 Provider-Specific Consumer Signal Boosters Compliance Measurements Guidance (February 12, 2016).

1.8 TEST FACILITY LOCATION

1.8.1 TÜV SÜD America Inc. (Mira Mesa)

10040 Mesa Rim Road, San Diego, CA 92121-2912 (32.901268,-117.177681). Phone: 858 678 1400 FAX: 858-546 0364

1.8.2 TÜV SÜD America Inc. (Rancho Bernardo)

16936 Via Del Campo, San Diego, CA 92127-1708 (33.018644,-117.092409). Phone: 858 678-1400 Fax: 858 546 0364.

1.9 TEST FACILITY REGISTRATION

1.9.1 FCC – Registration No.: US1146

TUV SUD America Inc. (San Diego), is an accredited test facility with the site description report on file and has met all the requirements specified in §2.948 of the FCC rules. The acceptance letter from the FCC is maintained in our files and the Registration is US1146.

1.9.2 Innovation, Science and Economic Development Canada Registration No.: 3067A

The 10m Semi-anechoic chamber of TÜV SÜD America Inc. (San Diego) has been registered by Certification and Engineering Bureau of Innovation, Science and Economic Development Canada for radio equipment testing with Registration No. 3067A.

SECTION 2

TEST DETAILS

Radio Testing of the
Nextivity Inc.
Cel-Fi GO Cellphone Signal Repeater

2.1 AUTHORIZED FREQUENCY BAND VERIFICATION

2.1.1 Specification Reference

FCC 47 CFR Part 20, Clause 20.21 (e)(3)
FCC 47 CFR Part 20, Clause 20.21(e)(4)
KDB935210 D04, Clause 7.1.1

2.1.2 Standard Applicable

FCC 47 CFR Part 20, Clause 20.21 (e)(3) Frequency Bands:

Consumer Signal Boosters must be designed and manufactured such that they only operate on the frequencies used for the provision of subscriber-based services under parts 22 (Cellular), 24 (Broadband PCS), 27 (AWS-1, 700 MHz Lower A-E Blocks, and 700 MHz Upper C Block), and 90 (Specialized Mobile Radio) of this chapter. The Commission will not certificate any Consumer Signal Boosters for operation on part 90 of this chapter (Specialized Mobile Radio) frequencies until the Commission releases a public notice announcing the date Consumer Signal Boosters may be used in the band.

FCC 47 CFR Part 20, Clause 20.21(e)(4) Self Monitoring:

The subscriber operates the Consumer Signal Booster on frequencies used for the provision of subscriber-based services under parts 22 (Cellular), 24 (Broadband PCS), 27 (AWS-1, 700 MHz Lower A-E Blocks, and 700 MHz Upper C Block), and 90 (Specialized Mobile Radio) of this chapter. Operation on part 90 (Specialized Mobile Radio) frequencies is permitted upon the Commission's release of a public notice announcing the date Consumer Signal Boosters may be used in the band;

2.1.3 Equipment Under Test and Modification State

Serial No: 332633000356 / Test Configuration A and B

2.1.4 Date of Test/Initial of test personnel who performed the test

December 22, 2016/XYZ

2.1.5 Test Equipment Used

The major items of test equipment used for the above tests are identified in Section 3.1.

2.1.6 Environmental Conditions

Test performed at TÜV SÜD America Inc. Rancho Bernardo facility.

Ambient Temperature	22.7°C
Relative Humidity	56.6%
ATM Pressure	98.7kPa

2.1.7 Additional Observations

- 1) This is conducted Test. Test procedure is per Section 7.1.1 of KDB935210 (D04 Provider Specific Booster Measurements v02). Appropriate offset (line losses) applied.
- 2) The Fix Unit operated in Test Mode, with the gain manually set to the maximum gain and a minimum bandwidth setting (5MHz).
- 3) Setup the EUT according to Figure 2 or 3 of Section 6.3.3 of KDB935210 (D04 Provider Specific Booster Measurements v02) as appropriate.
- 4) Evaluations are conducted at Server and Donor antenna ports.
- 5) All operational uplink and downlink bands for WCDMA Band 2, 5, and LTE Band 2, 5, 12, 13, and 4 were tested.
- 6) The signal generator was set to transmit a 5MHz LTE or WCDMA signal.
- 7) DL: B2: 1930 – 1990MHz; B5: 869 - 894MHz, B12:729 – 746MHz; B13: 746 – 756 MHz;
B4:2110 – 2155MHz;
UL: B2: 1850 – 1910MHz; B5: 824 - 849MHz, B12:699 – 716MHz; B13: 777 – 787 MHz;
B4:1710 – 1755MHz;

2.1.8 Test Results

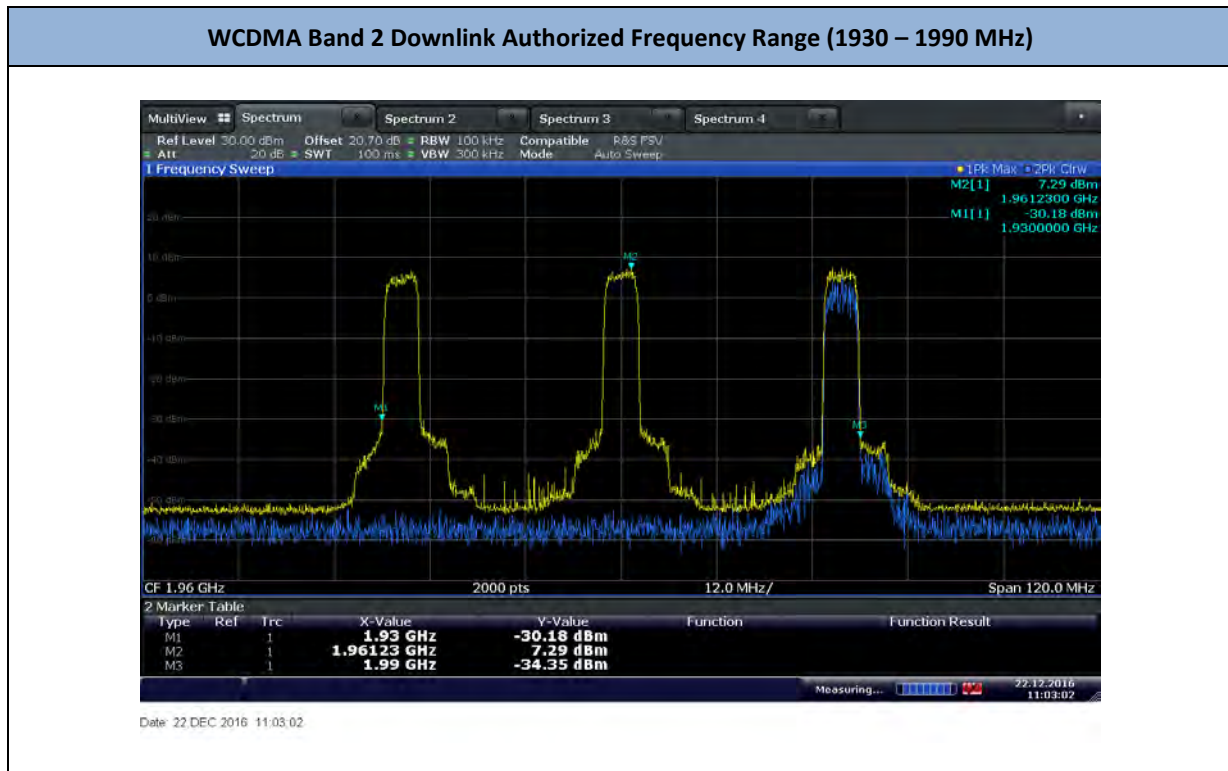

WCDMA Band 2 Uplink Authorized Frequency Range (1850 – 1910 MHz)

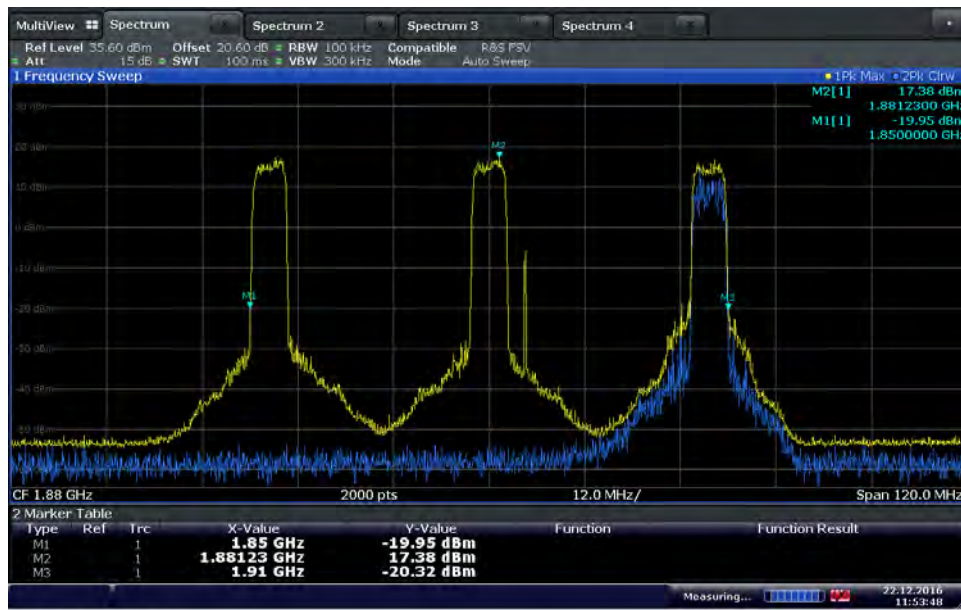

Date: 22 DEC 2016 11:53:48

LTE Band 2 Downlink Authorized Frequency Range (1930 – 1990 MHz)

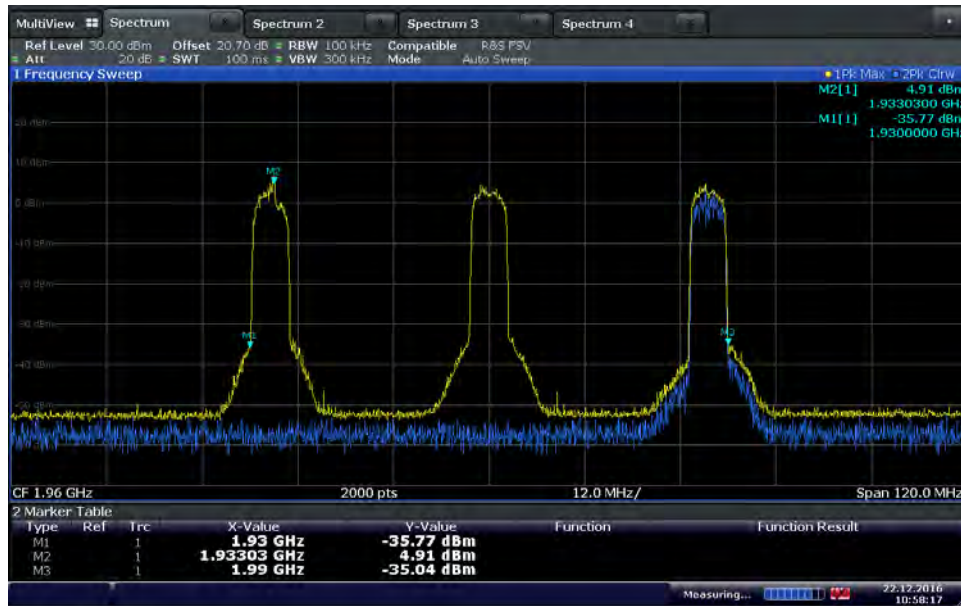

Date: 22 DEC 2016 10:58:17

LTE Band 2 Uplink Authorized Frequency Range (1850 – 1910 MHz)

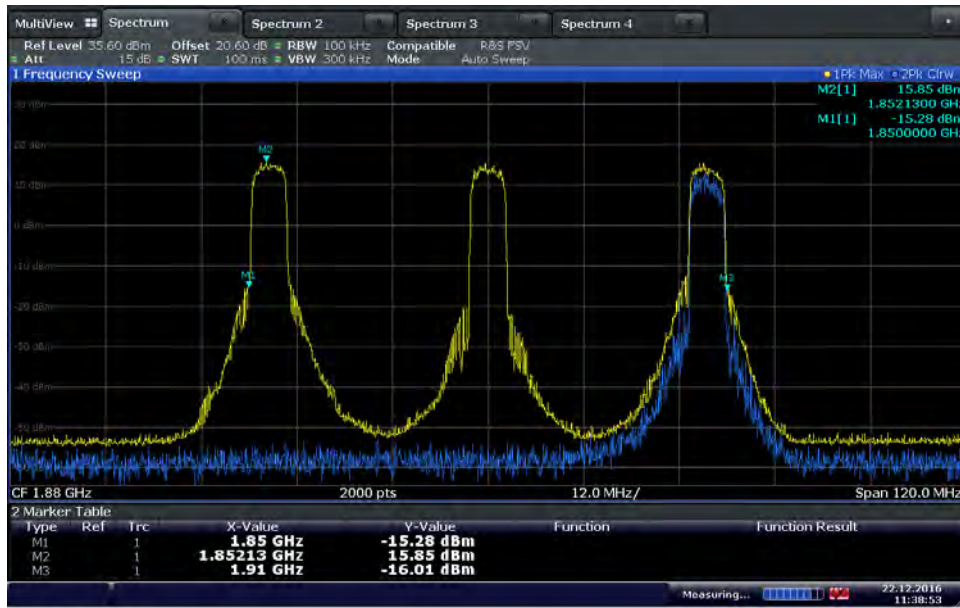

Date: 22 DEC 2016 11:38:53

WCDMA Band 5 Downlink Authorized Frequency Range (869 – 894 MHz)

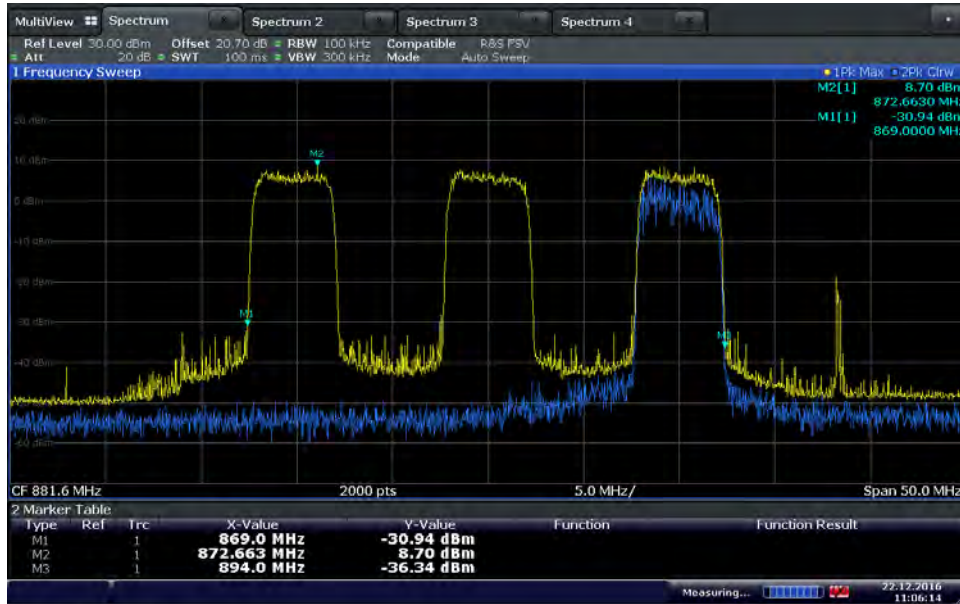

Date: 22 DEC 2016 11:06:14

WCDMA Band 5 Uplink Authorized Frequency Range (824 – 849 MHz)

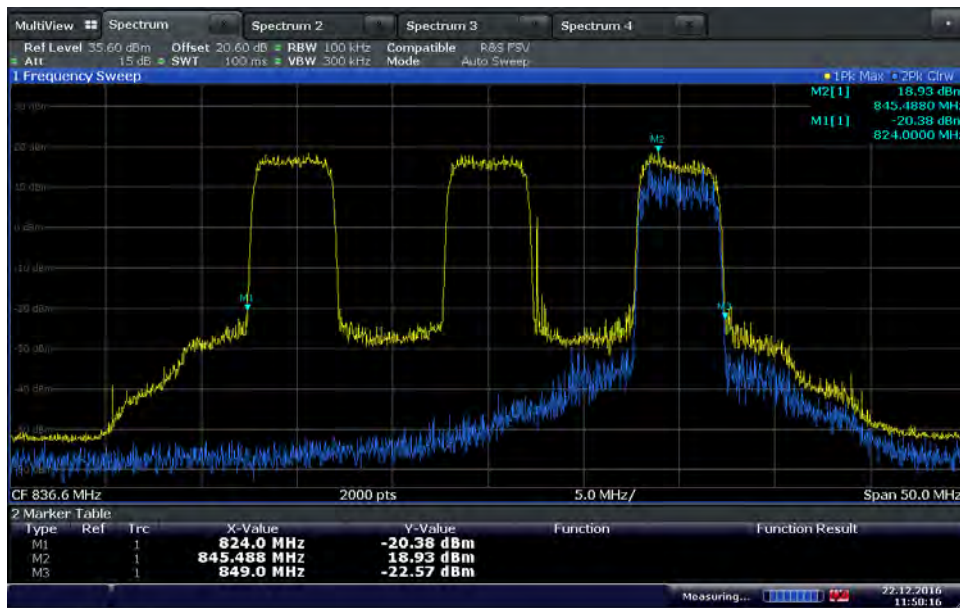

LTE Band 5 Downlink Authorized Frequency Range (869 – 894 MHz)

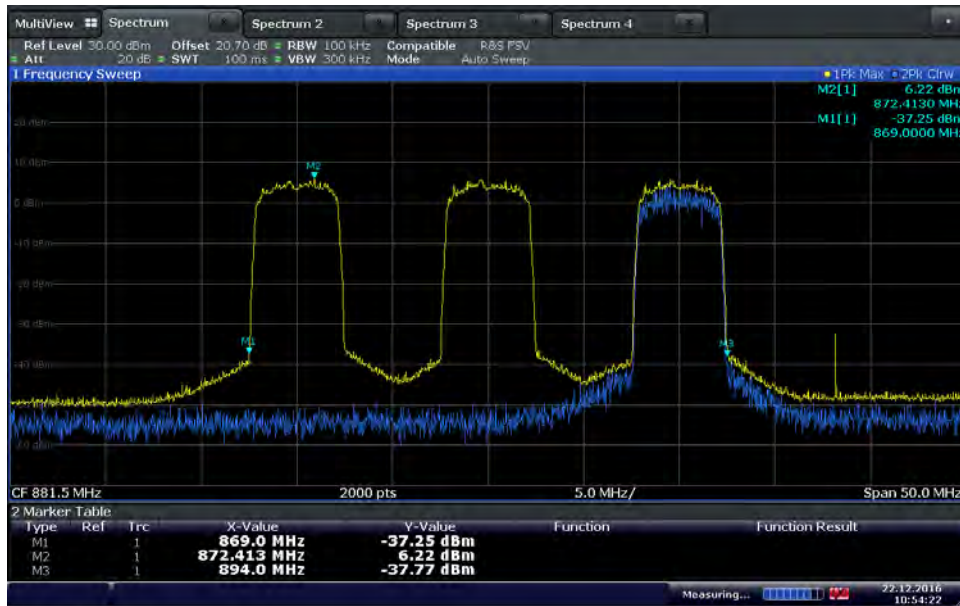

LTE Band 5 Uplink Authorized Frequency Range (824 – 849 MHz)

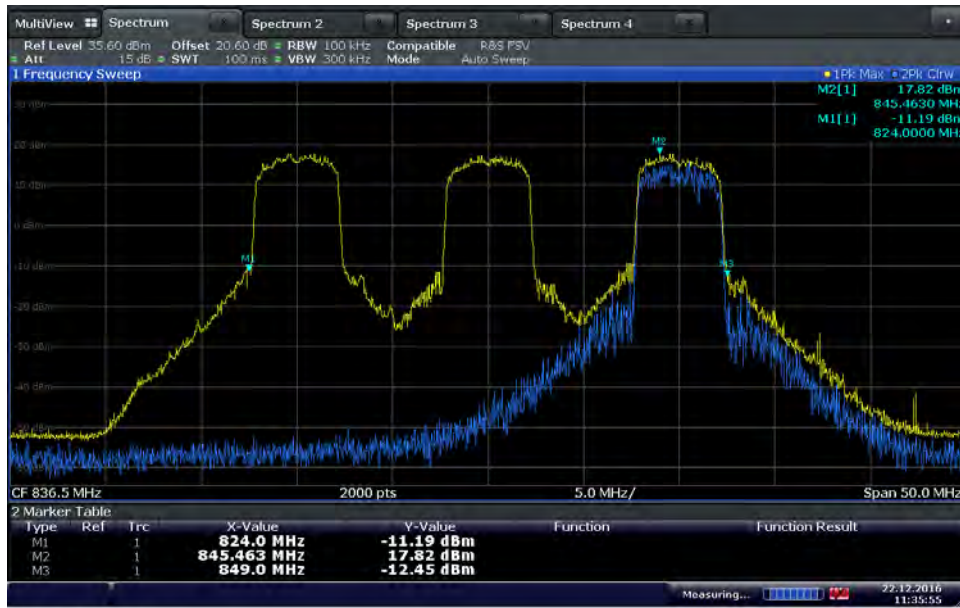

Date: 22 DEC 2016 11:35:55

LTE Band 12 Downlink Authorized Frequency Range (729 – 746 MHz)



Date: 22 DEC 2016 10:49:50

LTE Band 12 Uplink Authorized Frequency Range (699 – 716 MHz)



LTE Band 13 Downlink Authorized Frequency Range (746 – 756 MHz)

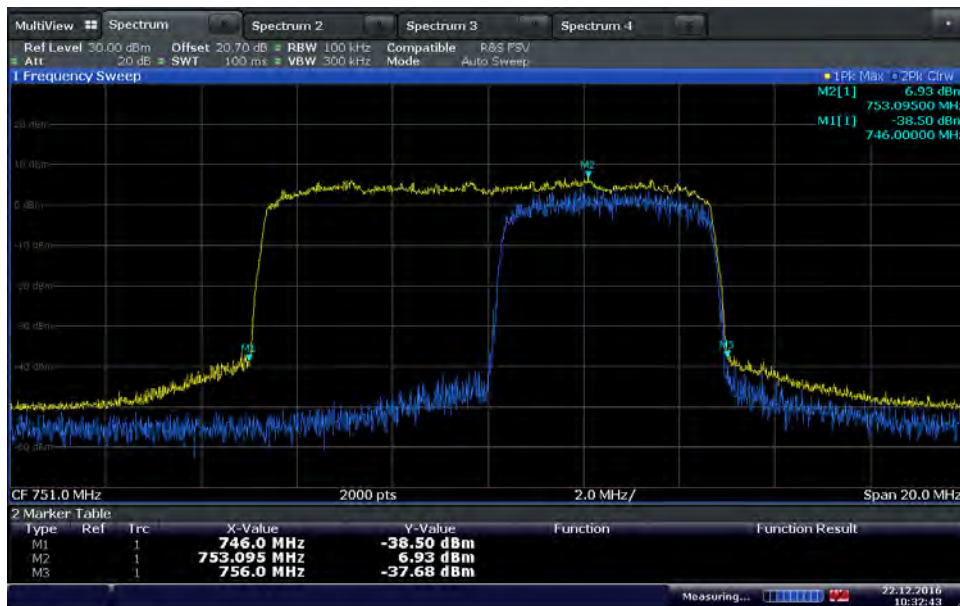

LTE Band 13 Uplink Authorized Frequency Range (777 – 787 MHz)



Date: 22 DEC 2016 11:45:03

LTE Band 4 Downlink Authorized Frequency Range (2110 – 2155 MHz)

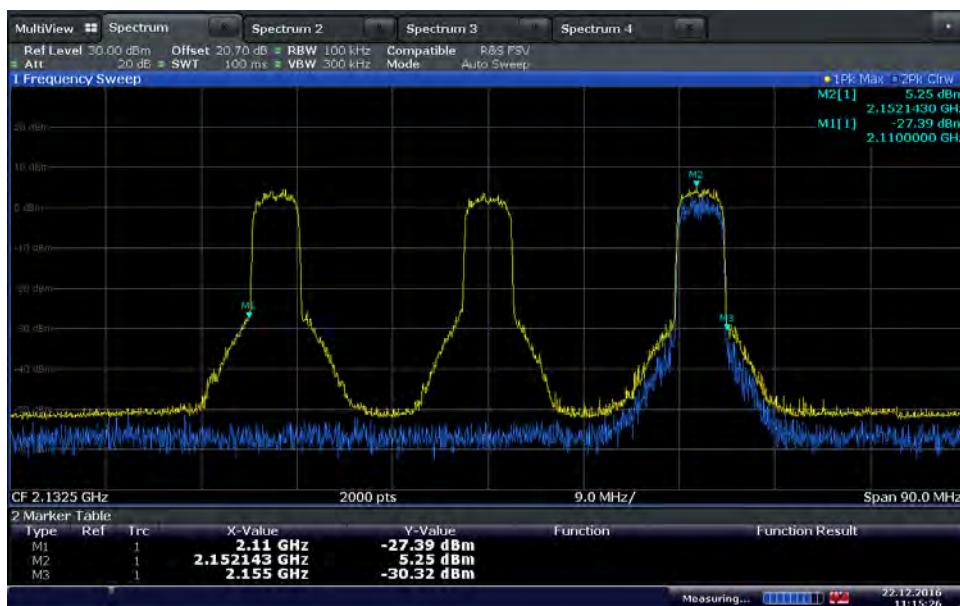

Date: 22 DEC 2016 11:15:27

LTE Band 4 Uplink Authorized Frequency Range (1710 – 1755 MHz)

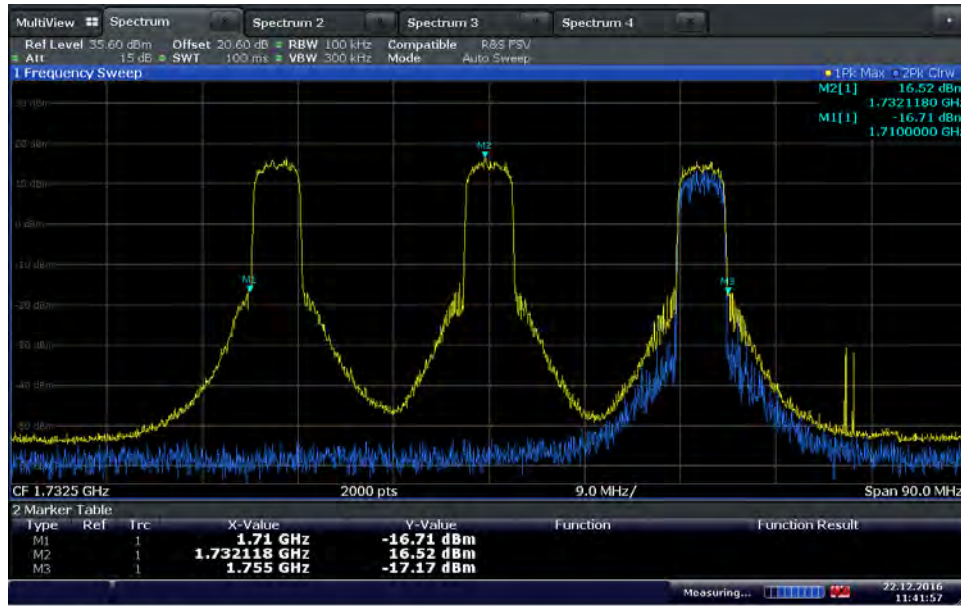

Date: 22 DEC 2016 11:41:57

2.2 AUTHORIZED CMRS PROVIDER

2.2.1 Specification Reference

FCC 47 CFR Part 20, Clause 20.21 (e)(3)
FCC 47 CFR Part 20, Clause 20.21(e)(4)
KDB935210 D04, Clause 7.1.2

2.2.2 Standard Applicable

FCC 47 CFR Part 20, Clause 20.21 (e)(3) Frequency Bands:

Consumer Signal Boosters must be designed and manufactured such that they only operate on the frequencies used for the provision of subscriber-based services under parts 22 (Cellular), 24 (Broadband PCS), 27 (AWS-1, 700 MHz Lower A-E Blocks, and 700 MHz Upper C Block), and 90 (Specialized Mobile Radio) of this chapter. The Commission will not certificate any Consumer Signal Boosters for operation on part 90 of this chapter (Specialized Mobile Radio) frequencies until the Commission releases a public notice announcing the date Consumer Signal Boosters may be used in the band.

FCC 47 CFR Part 20, Clause 20.21(e)(4) Self Monitoring:

The subscriber operates the Consumer Signal Booster on frequencies used for the provision of subscriber-based services under parts 22 (Cellular), 24 (Broadband PCS), 27 (AWS-1, 700 MHz Lower A-E Blocks, and 700 MHz Upper C Block), and 90 (Specialized Mobile Radio) of this chapter. Operation on part 90 (Specialized Mobile Radio) frequencies is permitted upon the Commission's release of a public notice announcing the date Consumer Signal Boosters may be used in the band;

2.2.3 Equipment Under Test and Modification State

Serial No: 332633000271 / Test Configuration C and D

2.2.4 Date of Test/Initial of test personnel who performed the test

December 28, 2016/XYZ

2.2.5 Test Equipment Used

The major items of test equipment used for the above tests are identified in Section 3.1.

2.2.6 Environmental Conditions

Test performed at TÜV SÜD America Inc. Rancho Bernardo facility.

Ambient Temperature	20.2°C
Relative Humidity	29.7%
ATM Pressure	99.5kPa

2.2.7 Additional Observations

- 1) This is conducted Test. Test procedure is per Section 7.1.2 of KDB935210 (D04 Provider Specific Booster Measurements v02). Appropriate offset (line losses) applied.
- 2) The Fix unit operated in Normal Mode, with the gain manually set to the maximum gain and a minimum bandwidth setting (5MHz).
- 3) Setup the EUT according to Figure 1 of Section 6.3.2 of KDB935210 (D04 Provider Specific Booster Measurements v02) with the Base Station Simulator transmitting an authorized CMRS provider signal to the booster.
- 4) Evaluations are conducted at Server and Donor antenna ports.
- 5) All operational uplink and downlink bands for WCDMA Band 2, 5, and LTE Band 2, 5, 12, 13 and 4 were tested.
- 6) The Base Station Simulator was set to transmit a 5MHz LTE signal or WCDMA.
- 7) The authorized CMRS Provider ID: 310/410
- 8) Two Non- authorized CMRS Provider signals were verified.
- 9) DL: B2: 1930 – 1990MHz; B5: 869 - 894MHz, B12: 729 – 746MHz; B13: 746 – 756 MHz;
B4: 2110 – 2155MHz;
UL: B2: 1850 – 1910MHz; B5: 824 - 849MHz, B12: 699 – 716MHz; B13: 777 – 787 MHz;
B4: 1710 – 1755MHz;

2.2.8 Test Results

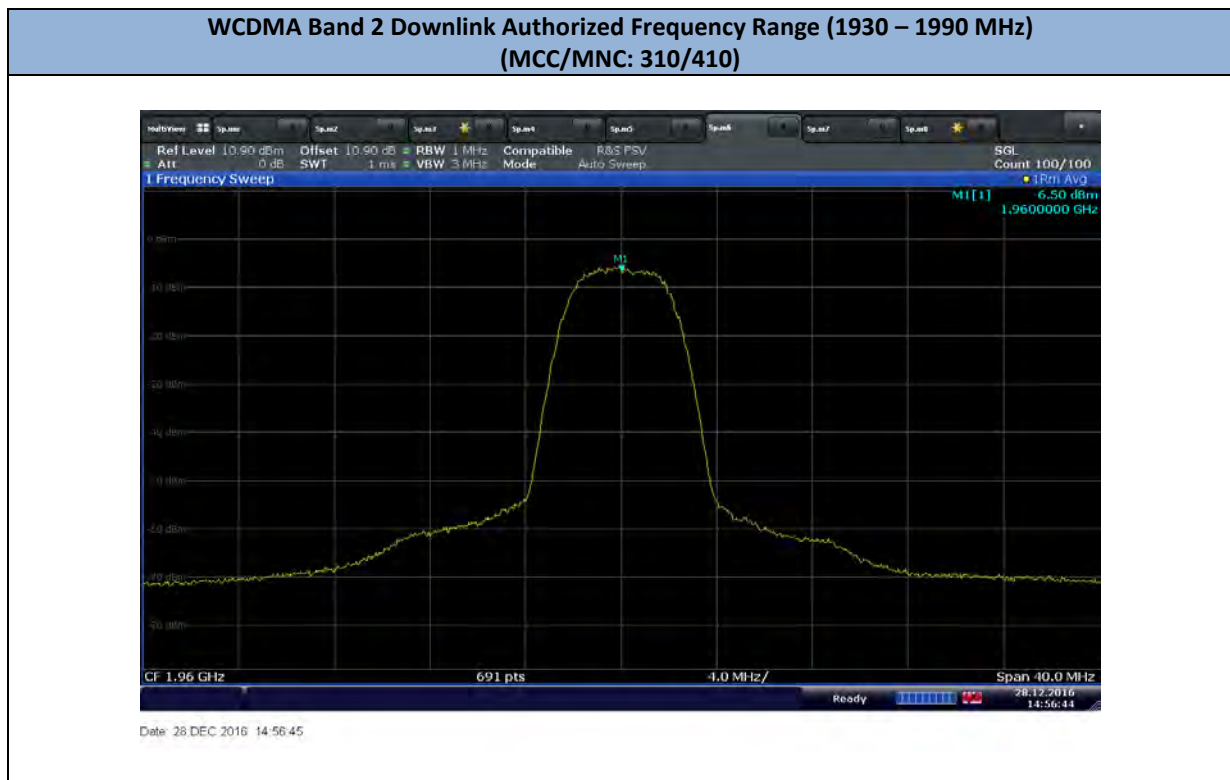

WCDMA Band 2 Downlink Authorized Frequency Range (1930 – 1990 MHz)
(MCC/MNC: 310/070)



Date: 28 DEC 2016 13:00:43

WCDMA Band 2 Downlink Authorized Frequency Range (1930 – 1990 MHz)
(MCC/MNC: 310/120)



Date: 28 DEC 2016 13:03:01

WCDMA Band 2 Uplink Authorized Frequency Range (1850 – 1910 MHz)
(MCC/MNC: 310/410)

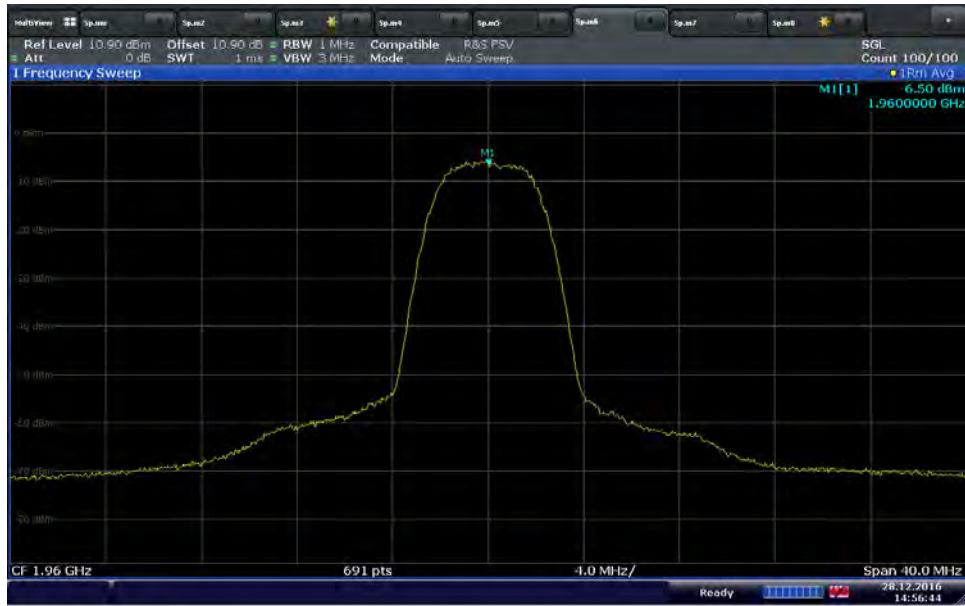

Date: 28 DEC 2016 14:56:45

WCDMA Band 2 Uplink Authorized Frequency Range (1850 – 1910 MHz)
(MCC/MNC: 310/070)



Date: 28 DEC 2016 13:02:43

WCDMA Band 2 Uplink Authorized Frequency Range (1850 – 1910 MHz)
(MCC/MNC: 310/120)



LTE Band 2 Downlink Authorized Frequency Range (1930 – 1990 MHz)
(MCC/MNC: 310/410)

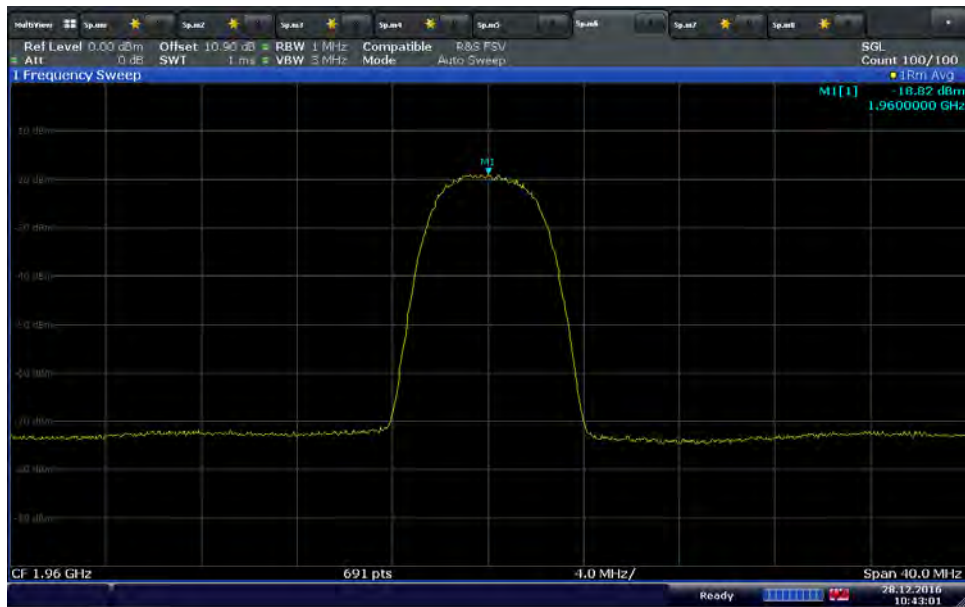

LTE Band 2 Downlink Authorized Frequency Range (1930 – 1990 MHz)
(MCC/MNC: 310/070)



Date: 28 DEC 2016 13:00:19

LTE Band 2 Downlink Authorized Frequency Range (1930 – 1990 MHz)
(MCC/MNC: 310/120)



Date: 28 DEC 2016 12:59:51

LTE Band 2 Uplink Authorized Frequency Range (1850 – 1910 MHz)
(MCC/MNC: 310/410)

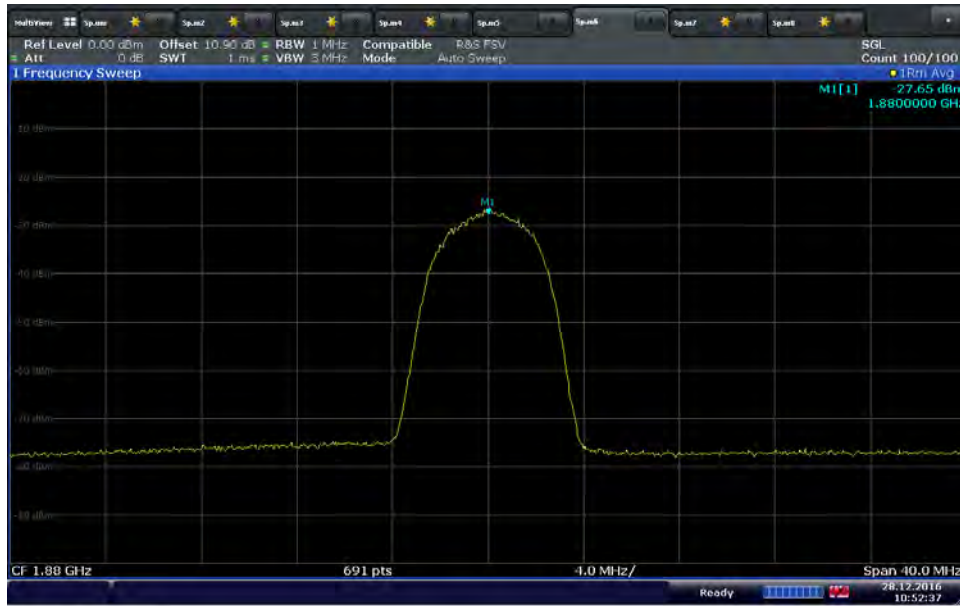

Date: 28 DEC 2016 10:52:37

LTE Band 2 Uplink Authorized Frequency Range (1850 – 1910 MHz)
(MCC/MNC: 310/070)



Date: 28 DEC 2016 13:01:44

**LTE Band 2 Uplink Authorized Frequency Range (1850 – 1910 MHz)
(MCC/MNC: 310/120)**



Date: 28 DEC 2016 13:02:16

**WCDMA Band 5 Downlink Authorized Frequency Range (869 – 894 MHz)
(MCC/MNC: 310/410)**

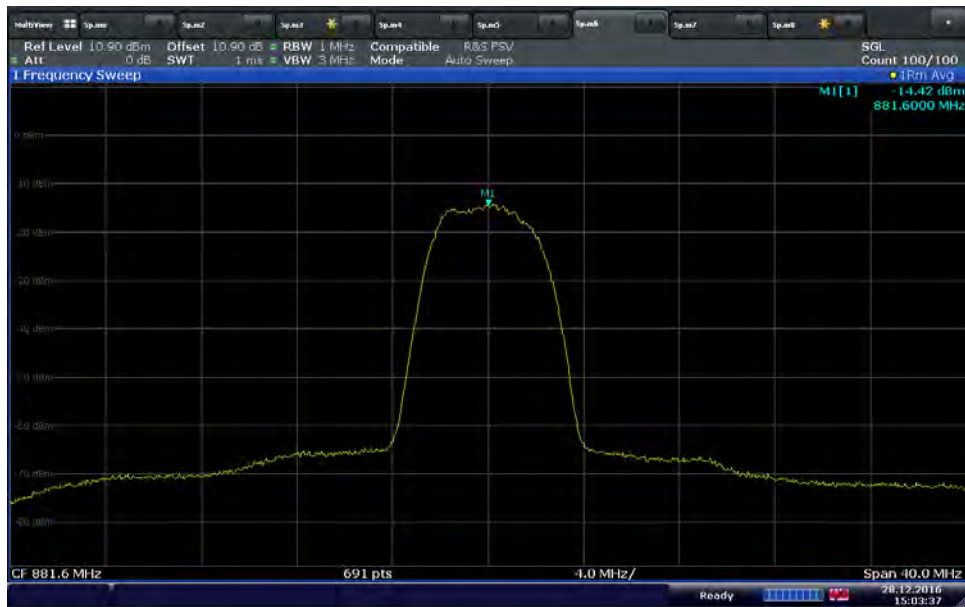

Date: 28 DEC 2016 15:03:37

**WCDMA Band 5 Downlink Authorized Frequency Range (869 – 894 MHz)
(MCC/MNC: 310/070)**

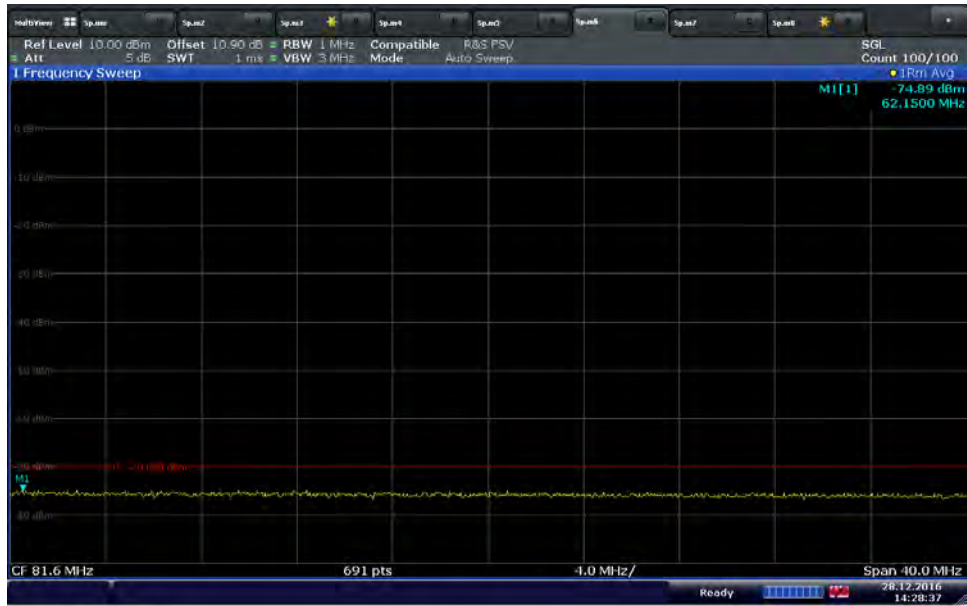

Date: 28 DEC 2016 14:28:37

**WCDMA Band 5 Downlink Authorized Frequency Range (869 – 894 MHz)
(MCC/MNC: 310/120)**



Date: 28 DEC 2016 14:29:17

WCDMA Band 5 Uplink Authorized Frequency Range (824 – 849 MHz)
(MCC/MNC: 310/410)

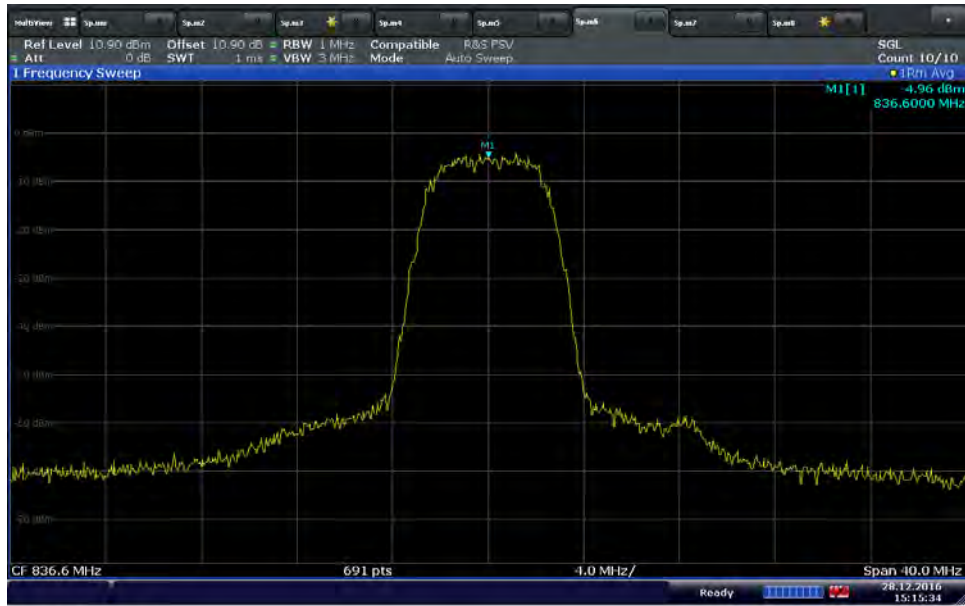

Date: 28 DEC 2016 15:15:34

WCDMA Band 5 Uplink Authorized Frequency Range (824 – 849 MHz)
(MCC/MNC: 310/070)

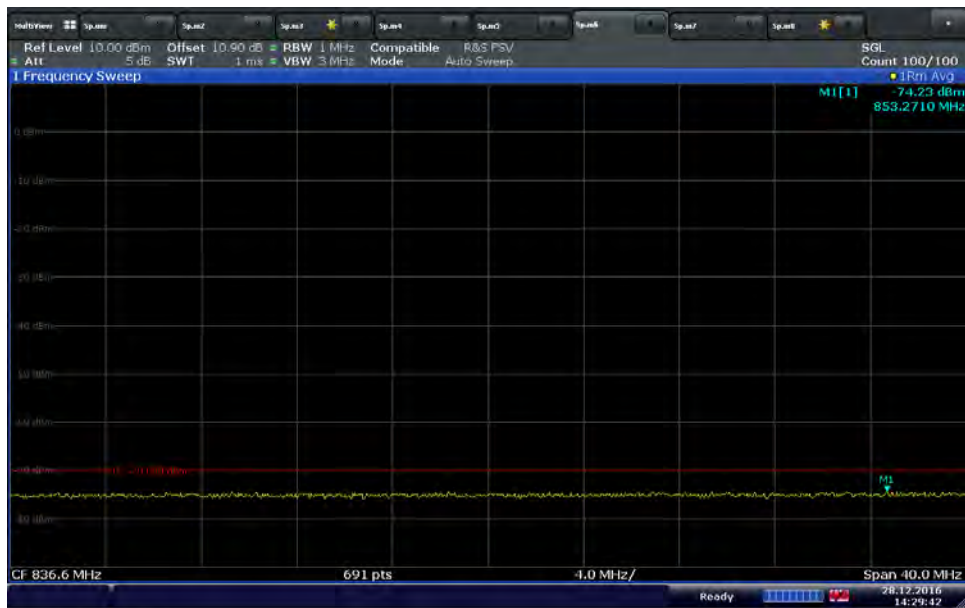

Date: 28 DEC 2016 14:29:42

**WCDMA Band 5 Uplink Authorized Frequency Range (824 – 849 MHz)
(MCC/MNC: 310/120)**



Date: 28 DEC 2016 14:29:55

**LTE Band 5 Downlink Authorized Frequency Range (869 – 894 MHz)
(MCC/MNC: 310/410)**

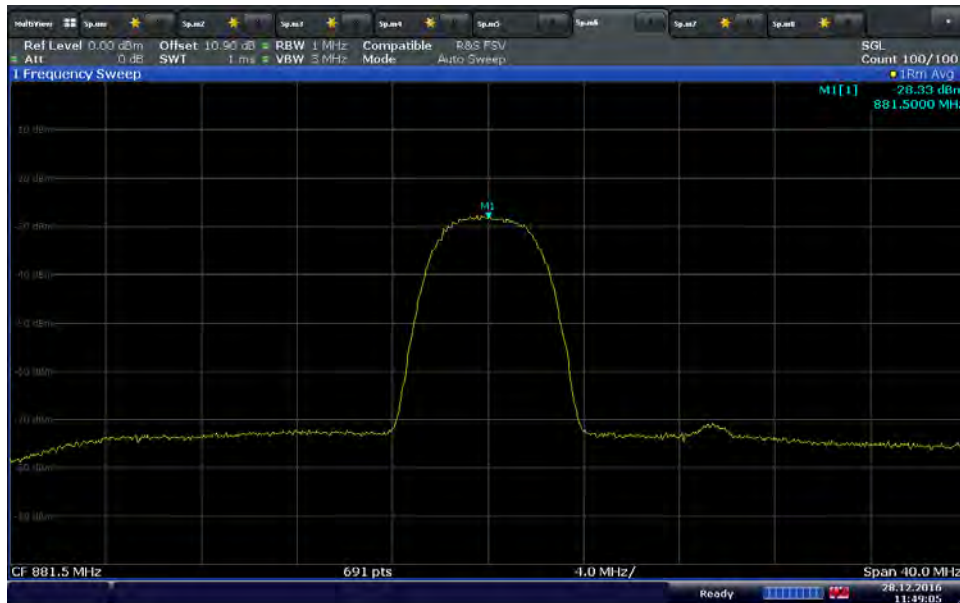

Date: 28 DEC 2016 11:49:05

LTE Band 5 Downlink Authorized Frequency Range (869 – 894 MHz)
(MCC/MNC: 310/070)

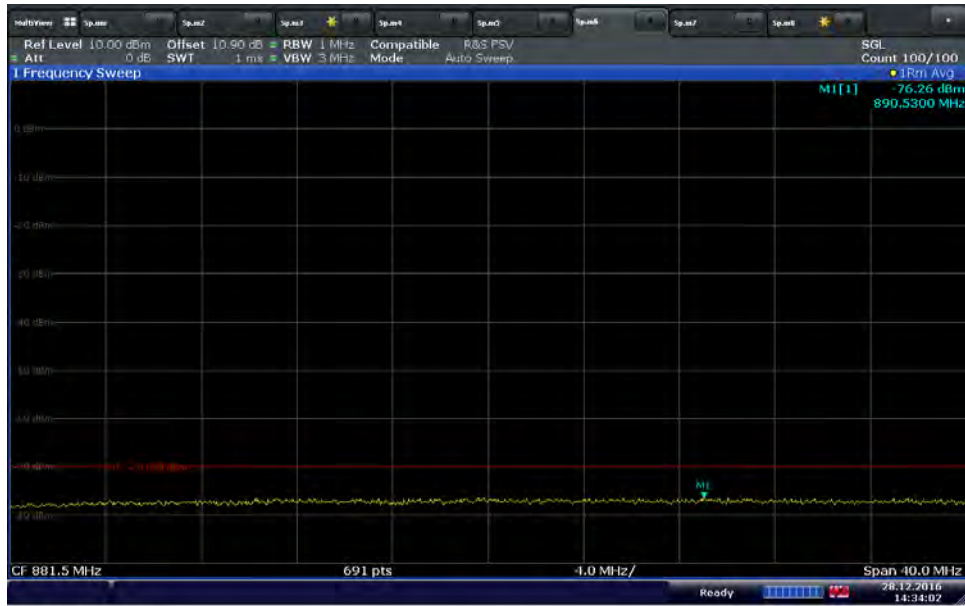

Date: 28 DEC 2016 14:34:03

LTE Band 5 Downlink Authorized Frequency Range (869 – 894 MHz)
(MCC/MNC: 310/120)



Date: 28 DEC 2016 14:34:17

LTE Band 5 Uplink Authorized Frequency Range (824 – 849 MHz)
(MCC/MNC: 310/410)

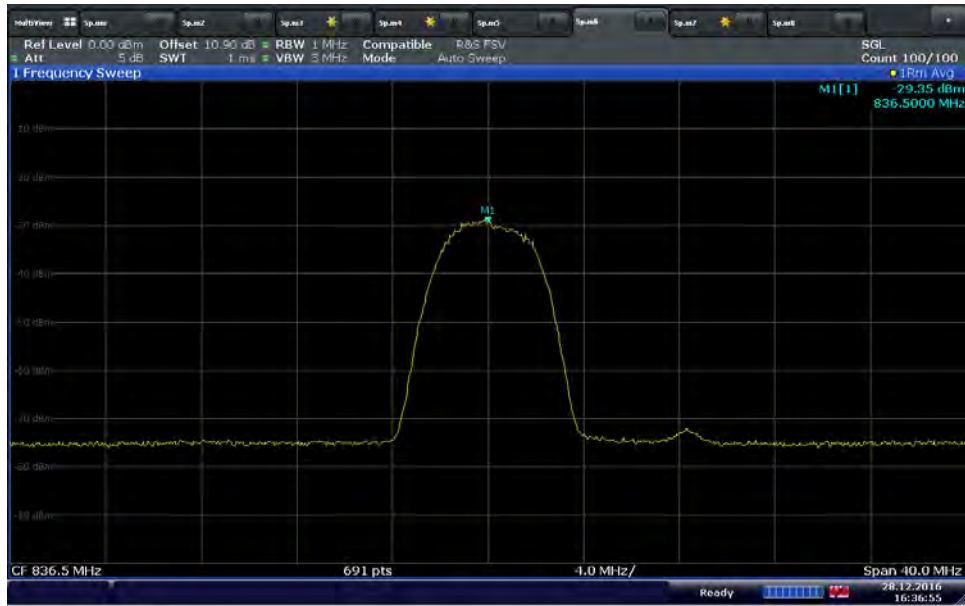

Date: 28 DEC 2016 16:36:55

LTE Band 5 Uplink Authorized Frequency Range (824 – 849 MHz)
(MCC/MNC: 310/070)



Date: 28 DEC 2016 14:34:50

LTE Band 5 Uplink Authorized Frequency Range (824 – 849 MHz)
(MCC/MNC: 310/120)



LTE Band 12 Downlink Authorized Frequency Range (729 – 746 MHz)
(MCC/MNC: 310/410)

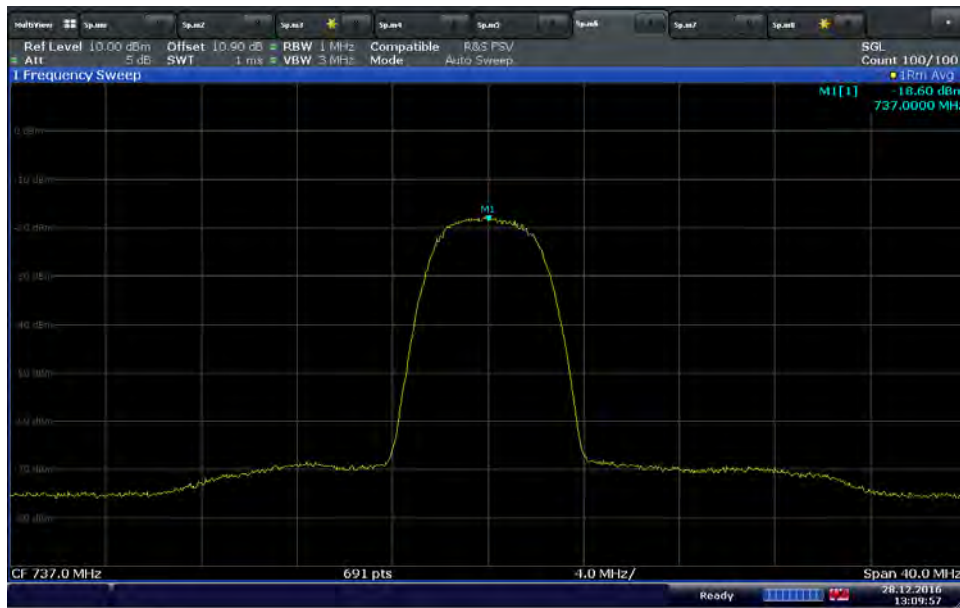

LTE Band 12 Downlink Authorized Frequency Range (729 – 746 MHz)
(MCC/MNC: 310/070)

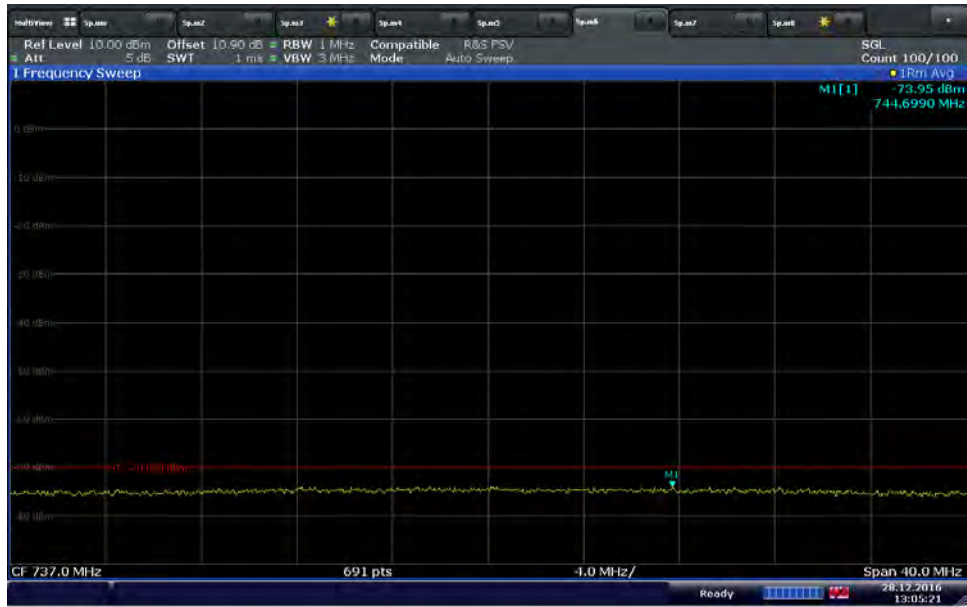

Date: 28 DEC 2016 13:05:22

LTE Band 12 Downlink Authorized Frequency Range (729 – 746 MHz)
(MCC/MNC: 310/120)



Date: 28 DEC 2016 13:05:49

LTE Band 12 Uplink Authorized Frequency Range (699 – 716 MHz)
(MCC/MNC: 310/410)

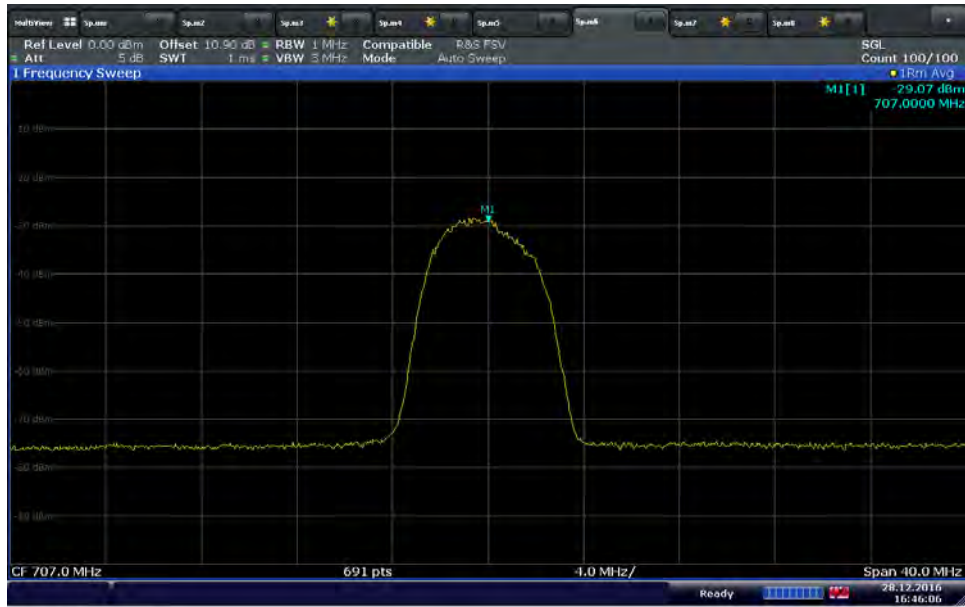

Date: 28 DEC 2016 16:46:06

LTE Band 12 Uplink Authorized Frequency Range (699 – 716 MHz)
(MCC/MNC: 310/070)



Date: 28 DEC 2016 13:06:12

LTE Band 12 Uplink Authorized Frequency Range (699 – 716 MHz)
(MCC/MNC: 310/120)



Date: 28 DEC 2016 13:06:37

LTE Band 13 Downlink Authorized Frequency Range (746 - 756 MHz)
(MCC/MNC: 310/410)

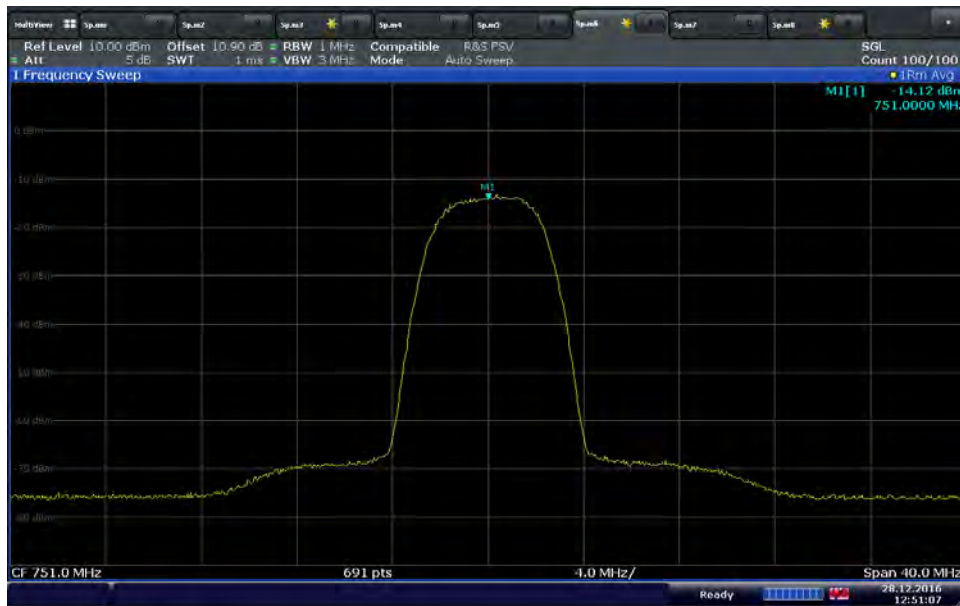

Date: 28 DEC 2016 12:51:08

LTE Band 13 Downlink Authorized Frequency Range (746 - 756 MHz)
(MCC/MNC: 310/070)



Date: 28 DEC 2016 11:00:44

LTE Band 13 Downlink Authorized Frequency Range (746 - 756 MHz)
(MCC/MNC: 310/120)



Date: 28 DEC 2016 11:01:08

LTE Band 13 Uplink Authorized Frequency Range (777 - 787 MHz)
(MCC/MNC: 310/410)

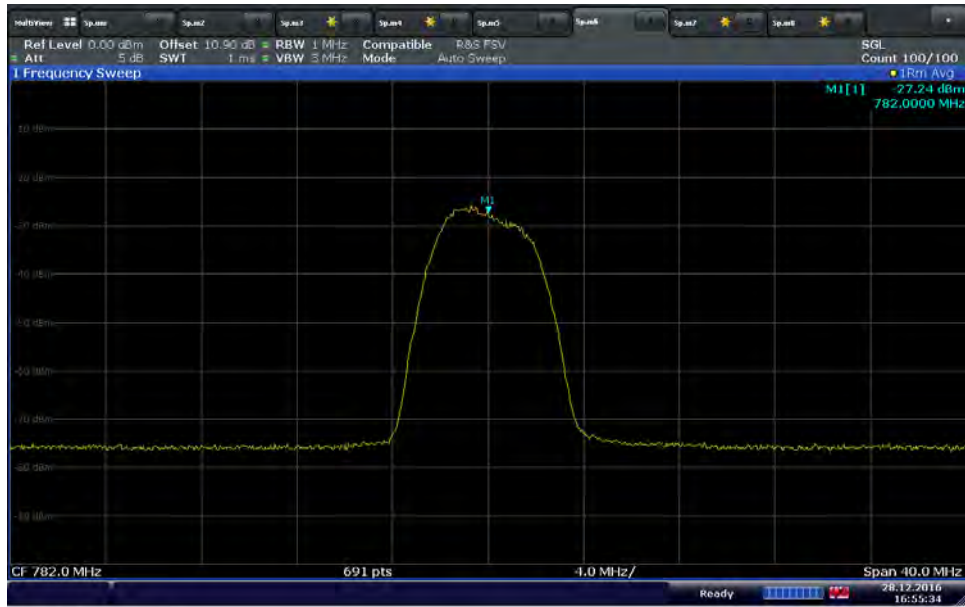

Date: 28 DEC 2016 16:55:34

LTE Band 13 Uplink Authorized Frequency Range (777 - 787 MHz)
(MCC/MNC: 310/070)



Date: 28 DEC 2016 11:02:07

LTE Band 13 Uplink Authorized Frequency Range (777 - 787 MHz)
(MCC/MNC: 310/120)



Date: 28 DEC 2016 11:02:32

LTE Band 4 Downlink Authorized Frequency Range (2110 – 2155 MHz)
(MCC/MNC: 310/410)

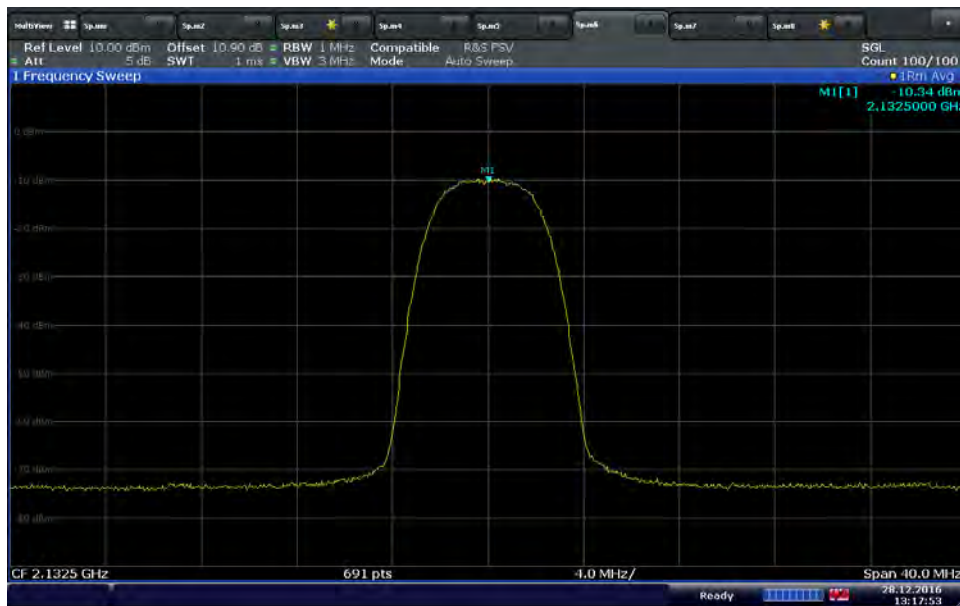

Date: 28 DEC 2016 13:17:53

LTE Band 4 Downlink Authorized Frequency Range (2110 – 2155 MHz)
(MCC/MNC: 310/070)



Date: 28 DEC 2016 13:14:53

LTE Band 4 Downlink Authorized Frequency Range (2110 – 2155 MHz)
(MCC/MNC: 310/120)

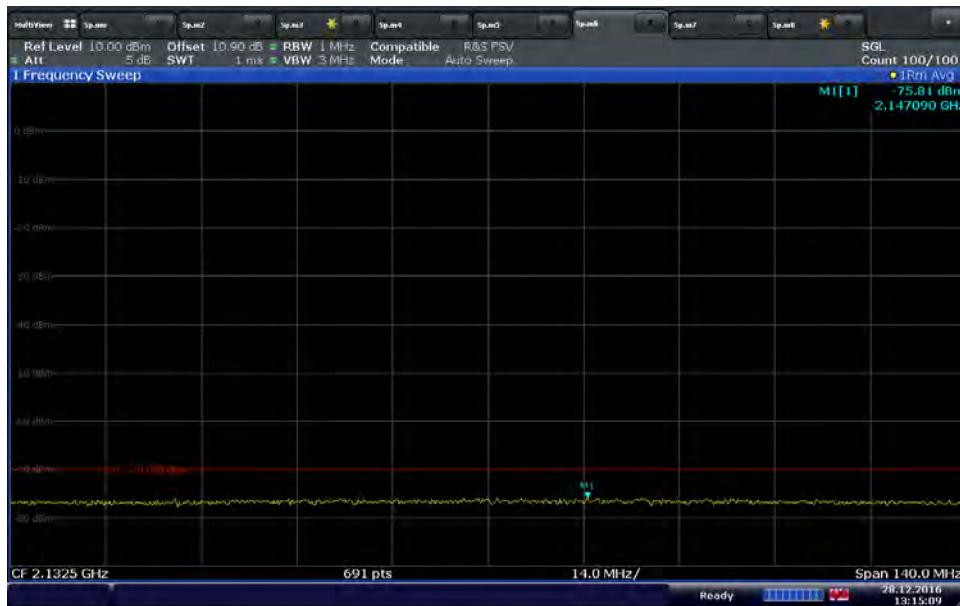

Date: 28 DEC 2016 13:15:09

LTE Band 4 Uplink Authorized Frequency Range (1710 – 1755 MHz)
(MCC/MNC: 310/410)

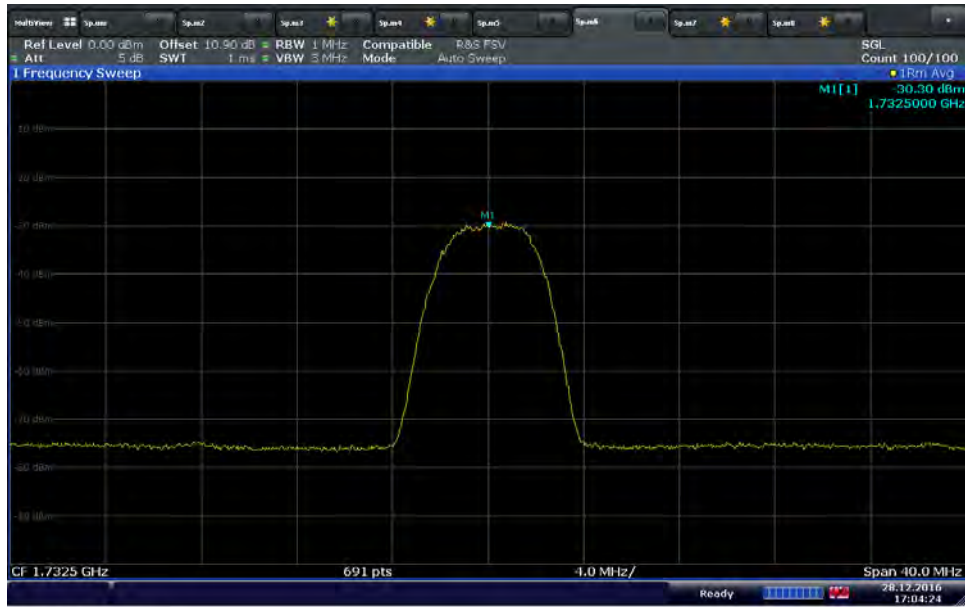

Date: 28 DEC 2016 17:04:25

LTE Band 4 Uplink Authorized Frequency Range (1710 – 1755 MHz)
(MCC/MNC: 310/070)



Date: 28 DEC 2016 13:16:47

**LTE Band 4 Uplink Authorized Frequency Range (1710 – 1755 MHz)
(MCC/MNC: 310/120)**



Date: 28 DEC 2016 13:17:13

WCDMA Band 2 Downlink Inactive time after reset (>30s)



Date: 28 DEC 2016 14:22:30

WCDMA Band 2 Uplink Inactive time after reset (>30s)



Date: 28 DEC 2016 16:12:06

LTE Band 2 Downlink Inactive time after reset (>30s)



Date: 28 DEC 2016 11:28:12

LTE Band 2 Uplink Inactive time after reset (>30s)



Date: 28 DEC 2016 14:59:15

WCDMA Band 5 Downlink Inactive time after reset (>30s)



Date: 28 DEC 2016 15:06:00

WCDMA Band 5 Uplink Inactive time after reset (>30s)



Date: 28 DEC 2016 15:27:44

LTE Band 5 Downlink Inactive time after reset (>30s)



Date: 28 DEC 2016 12:35:47

LTE Band 5 Uplink Inactive time after reset (>30s)



Date: 28 DEC 2016 12:42:33

LTE Band 12 Downlink Inactive time after reset (>30s)



Date: 28 DEC 2016 13:11:35

LTE Band 12 Uplink Inactive time after reset (>30s)



Date: 28 DEC 2016 16:49:46

LTE Band 13 Downlink Inactive time after reset (>30s)



Date: 28 DEC 2016 12:52:57

LTE Band 13 Uplink Inactive time after reset (>30s)



Date: 28 DEC 2016 16:59:44

LTE Band 4 Downlink Inactive time after reset (>30s)



Date: 28 DEC 2016 13:20:08

LTE Band 4 Uplink Inactive time after reset (>30s)



2.3 AUTHORIZED CMRS PROVIDER SPECTRUM FOR MOBILE DEVICES

2.3.1 Specification Reference

FCC 47 CFR Part 20, Clause 20.21 (e)(3)
FCC 47 CFR Part 20, Clause 20.21(e)(4)
KDB935210 D04, Clause 7.1.3

2.3.2 Standard Applicable

FCC 47 CFR Part 20, Clause 20.21 (e)(3) Frequency Bands:

Consumer Signal Boosters must be designed and manufactured such that they only operate on the frequencies used for the provision of subscriber-based services under parts 22 (Cellular), 24 (Broadband PCS), 27 (AWS-1, 700 MHz Lower A-E Blocks, and 700 MHz Upper C Block), and 90 (Specialized Mobile Radio) of this chapter. The Commission will not certificate any Consumer Signal Boosters for operation on part 90 of this chapter (Specialized Mobile Radio) frequencies until the Commission releases a public notice announcing the date Consumer Signal Boosters may be used in the band.

FCC 47 CFR Part 20, Clause 20.21(e)(4) Self Monitoring:

The subscriber operates the Consumer Signal Booster on frequencies used for the provision of subscriber-based services under parts 22 (Cellular), 24 (Broadband PCS), 27 (AWS-1, 700 MHz Lower A-E Blocks, and 700 MHz Upper C Block), and 90 (Specialized Mobile Radio) of this chapter. Operation on part 90 (Specialized Mobile Radio) frequencies is permitted upon the Commission's release of a public notice announcing the date Consumer Signal Boosters may be used in the band;

2.3.3 Equipment Under Test and Modification State

Serial No: 932703000059 / Test Configuration E

2.3.4 Date of Test/Initial of test personnel who performed the test

March 08, 2017/XYZ

2.3.5 Test Equipment Used

The major items of test equipment used for the above tests are identified in Section 3.1.

2.3.6 Environmental Conditions

Test performed at TÜV SÜD America Inc. Rancho Bernardo facility.

Ambient Temperature	24.6°C
Relative Humidity	32.5%
ATM Pressure	99.3kPa

2.3.7 Additional Observations

- 10) This is conducted Test. Test procedure is per Section 7.1.3 of KDB935210 (D04 Provider Specific Booster Measurements v02). Appropriate offset (line losses) applied.
- 11) The Mobile Unit operated in Normal Mode, with the gain manually set to the maximum gain and a minimum bandwidth setting (5MHz).
- 12) Setup the EUT in normal mode according to Figure 4 of Section 7.1.3 of KDB935210 (D04 Provider Specific Booster Measurements v02), with the Base Station Simulator #1 transmitting a fully loaded, authorized CMRS provider signal to the booster, and base station simulator #2 transmitting a fully loaded, no-authorized co-channel CMRS provider signal of both the same and different technology type to the booster
- 13) Evaluations are conducted at Server and Donor antenna ports.
- 14) All operational uplink and downlink bands for WCDMA Band 2, 5, and LTE Band 2, 5, 12, 13 and 4 were tested.
- 15) The Base Station Simulator was set to transmit a 5MHz LTE signal or WCDMA.
- 16) The authorized CMRS Provider ID: 310/410
- 17) Two Non- authorized CMRS Provider signals were verified.
- 18) DL: B2: 1930 – 1990MHz; B5: 869 - 894MHz, B12: 729 – 746MHz; B13: 746 – 756 MHz;
B4: 2110 – 2155MHz;
UL: B2: 1850 – 1910MHz; B5: 824 - 849MHz, B12: 699 – 716MHz; B13: 777 – 787 MHz;
B4: 1710 – 1755MHz;

2.3.8 Test Results

Band	Frequency (MHz)	Inactive Time (Sec)	Limit (Sec)	Margin (Sec)
WCDMA Band 2 Downlink	1960	2.19	5.0	2.81
WCDMA Band 2 Uplink	1880	2.78	5.0	2.22
LTE Band 2 Downlink	1960	2.84	5.0	2.16
LTE Band 2 Uplink	1880	2.15	5.0	2.85
WCDMA Band 5 Downlink	881.6	4.02	5.0	0.98
WCDMA Band 5 Uplink	836.6	4.06	5.0	0.94
LTE Band 5 Downlink	881.5	2.06	5.0	2.94
LTE Band 5 Uplink	836.5	2.28	5.0	2.72
LTE Band 12 Downlink	737.5	3.84	5.0	1.16
LTE Band 12 Uplink	707	2.15	5.0	2.85
LTE Band 13 Downlink	751	2.16	5.0	2.84
LTE Band 13 Uplink	782	2.15	5.0	2.85
LTE Band 4 Downlink	2132.5	2.12	5.0	2.88
LTE Band 4 Uplink	1732.5	2.13	5.0	2.87

2.3.9 Sample Test Results

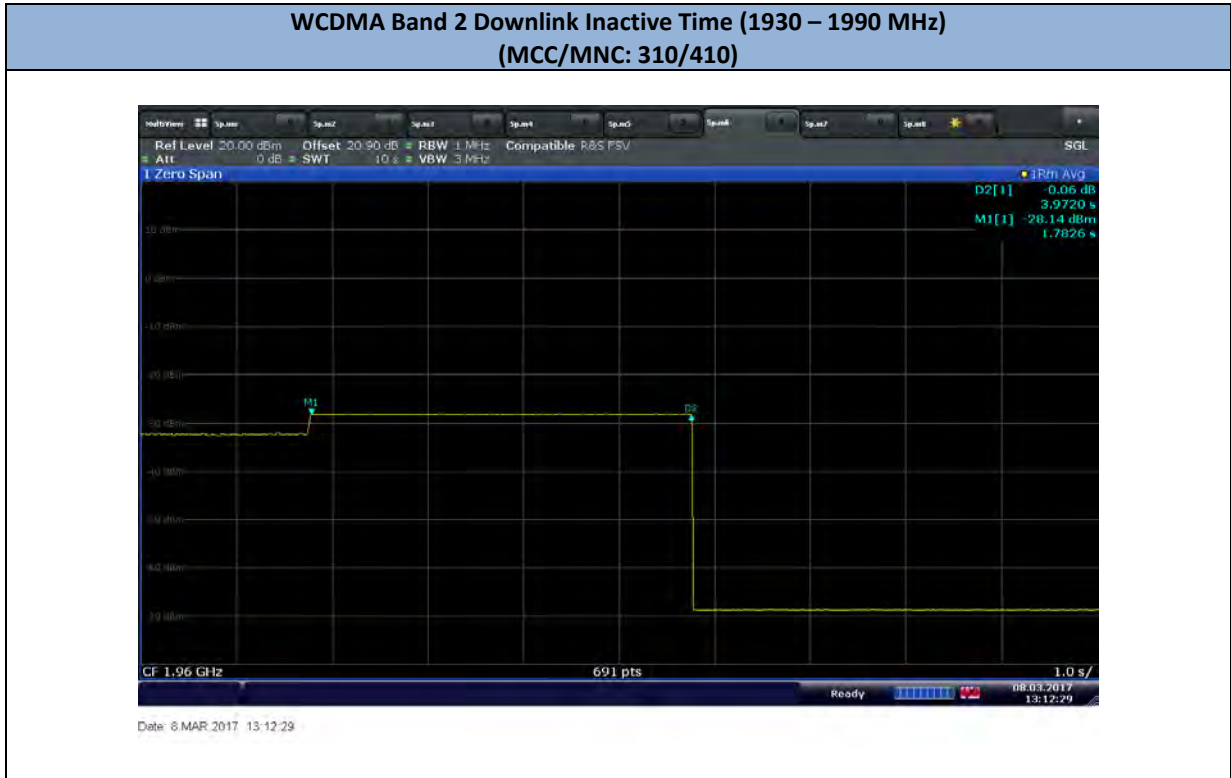

**WCDMA Band 2 Uplink Inactive Time (1850 – 1910 MHz)
(MCC/MNC: 310/410)**



**LTE Band 2 Downlink Inactive Time (1930 – 1990 MHz)
(MCC/MNC: 310/410)**



**LTE Band 2 Band 2 Uplink Inactive Time (1850 – 1910 MHz)
(MCC/MNC: 310/410)**



Date 8.MAR.2017 13:45:29

**WCDMA Band 5 Downlink Inactive Time (869 – 894 MHz)
(MCC/MNC: 310/410)**



Date 8.MAR.2017 11:54:25

**WCDMA Band 5 Uplink Inactive Time (824 – 849 MHz)
(MCC/MNC: 310/410)**



**LTE Band 5 Downlink Inactive Time (869 – 894 MHz)
(MCC/MNC: 310/410)**



**LTE Band 5 Uplink Inactive Time (824 – 849 MHz)
(MCC/MNC: 310/410)**



**LTE Band 12 Downlink Inactive Time (729 – 746 MHz)
(MCC/MNC: 310/410)**



**LTE Band 12 Uplink Downlink Inactive Time (699 – 716 MHz)
(MCC/MNC: 310/410)**



Date: 8.MAR.2017 13:59:11

**LTE Band 13 Downlink Inactive Time (746 - 756 MHz)
(MCC/MNC: 310/410)**



Date: 8.MAR.2017 12:41:29

**LTE Band 13 Uplink Inactive Time (777 - 787 MHz)
(MCC/MNC: 310/410)**



**LTE Band 4 Downlink Inactive Time (2110 – 2155 MHz)
(MCC/MNC: 310/410)**



LTE Band 4 Uplink Inactive Time (1710 – 1755 MHz)
(MCC/MNC: 310/410)

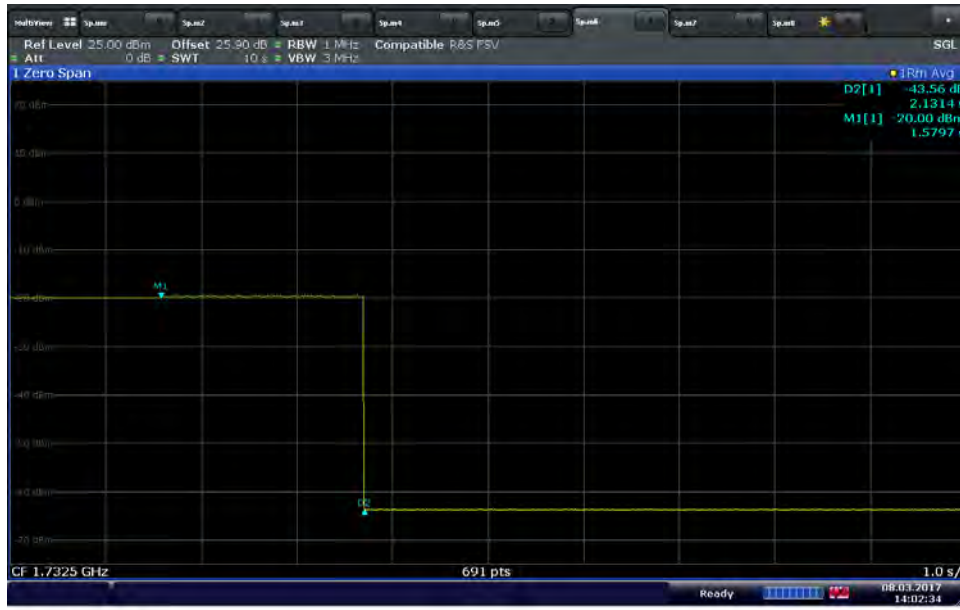

2.4 MAXIMUM POWER MEASUREMENT AND BOOSTER GAIN COMPUTATION

2.4.1 Specification Reference

FCC 47 CFR Part 20, Clause 20.21(e)(9)(i)(D)
FCC 47 CFR Part 20, Clause 20.21(e)(9)(i)(B)
FCC 47 CFR Part 20, Clause 20.21(e)(9)(i)(C)(2)
KDB935210 D04, Clause 7.2
KDB935210 D04, Clause 7.3

2.4.2 Standard Applicable

FCC 47 CFR Part 20, Clause 20.21(e)(9)(i)(B) Bidirectional Capability:
Consumer Boosters must be able to provide equivalent (within 9dB as per ANSI ASC C63) uplink and downlink gain and conducted uplink power output that is at least 0.05 watts. One-way consumer boosters (i.e., uplink only, downlink only, uplink impaired, downlink impaired) are prohibited. Spectrum block filtering used must provide uplink filter attenuation not less than the downlink filter attenuation, and where RSSI is measured after spectrum block filtering is applied referenced to the booster's input port for each band of operation.

FCC 47 CFR Part 20, Clause 20.21(e)(9)(i)(D) Power Limits:
A booster's uplink power must not exceed 1 watt composite conducted power and equivalent isotropic radiated power (EIRP) for each band of operation. Downlink power shall not exceed 0.05 watt (17dBm) composite and 10 dBm per channel conducted and EIRP for each band of operation. Compliance with power limits will use instrumentation calibrated in terms of RMS equivalent voltage.

FCC 47 CFR Part 20, Clause 20.21(e)(9)(i)(C) Booster Gain Limits.
The gain of the frequency selective consumer booster shall meet the limits below.
(2) The uplink and downlink maximum gain of a frequency selective consumer booster referenced to its input and output ports shall not exceed 19.5 dB + 20 Log (Frequency), or 100 dB for systems having automatic gain adjustment based on isolation measurements between booster donor and server antennas.
Where, Frequency is the uplink midband frequency of the supported spectrum bands in MHz.

2.4.3 Equipment Under Test and Modification State

Serial No: 332633000356 and 332633000271 / Test Configuration A and B

2.4.4 Date of Test/Initial of test personnel who performed the test

January 19 and 20, 2017/XYZ

2.4.5 Test Equipment Used

The major items of test equipment used for the above tests are identified in Section 3.1.

2.4.6 Environmental Conditions

Test performed at TÜV SÜD America Inc. Rancho Bernardo facility.

Ambient Temperature	20.8 - 21.1°C
Relative Humidity	49.5 - 59.6%

ATM Pressure

98.9 - 99.2kPa

2.4.7 Additional Observations

- 1) This is conducted Test. Test procedure is per Section 7.2.2 of KDB935210 (D04 Provider Specific Booster Measurements v02). Appropriate offset (line losses) applied.
- 2) The EUT operated in Test Mode, with the gain manually set to the maximum gain and a minimum bandwidth setting (5MHz).
- 3) Setup the EUT according to Figure 2 or 3 of Section 6.3.3 of KDB935210 (D04 Provider Specific Booster Measurements v02) as appropriate.
- 4) Evaluations are conducted at Server and Donor ports for WCDMA B2, B5, LTE B2, B5, B12, B13 and B4.
- 5) Maximum Gain of the booster was calculated.
- 6) The Gain with Maximum Transmitter Input Level (-20dBm for Downlink and 0dBm for Uplink) injected was also calculated.
- 7) Operational uplink and downlink bands for WCDMA Band 2, 5, and LTE Band 12 and 4 were tested.
- 8) Both Fix Unit and Mobile Units were tested.
- 9) The signal generator was set to transmit a 5MHz LTE or WCDMA signal.

2.4.8 Test Results

Maximum Gain/Maximum Power (Fix Unit)										
Band	Frequency Range (MHz)	Input Power (dBm)	Output Power (dBm)	Antenna Gain (dB)	EIRP (dBm)	EIRP Limit (dBm)	Gain (dB)	Gain Limit (dB)	UL vs DL Gain	UL vs DL Gain Limit (dB)
WCDMA Band 2 Downlink	1930 - 1990	-82.57	8.56	<8.44	<17	<17	91.13	100	1.47	9
WCDMA Band 2 Uplink	1850 - 1910	-74.19	19.41	2.41-10.59	17-30	17-30	93.6	100		
WCDMA Band 5 Downlink	869 - 894	-82.24	8.38	<8.62	<17	<17	90.62	100	3.17	9
WCDMA Band 5 Uplink	824 - 849	-73.56	20.23	3.23-9.77	17-30	17-30	93.79	100		
LTE Band 2 Downlink	1930 - 1990	-82.57	7.78	<9.22	<17	<17	90.35	100	2.02	9
LTE Band 2 Uplink	1850 - 1910	-73.27	19.10	2.1-10.9	17-30	17-30	92.37	100		
LTE Band 5 Downlink	869 - 894	-81.69	8.33	<8.67	<17	<17	90.02	100	4.62	9
LTE Band 5 Uplink	824 - 849	-74.18	20.46	3.46-9.54	17-30	17-30	94.64	100		
LTE Band 12 Downlink	729 - 746	-81.22	8.41	<8.59	<17	<17	89.63	100	4.56	9
LTE Band 12 Uplink	699 - 716	-73.7	20.49	3.49-9.51	17-30	17-30	94.19	100		
LTE Band 13 Downlink	746 - 756	-83.18	8.41	<8.59	<17	<17	91.59	100	2.7	9
LTE Band 13 Uplink	777 - 787	-73.58	20.71	3.71-9.29	17-30	17-30	94.29	100		
LTE Band 4 Downlink	2110 - 2200	-83.13	7.11	<9.89	<17	<17	90.24	100	2.6	9
LTE Band 4 Uplink	1710 - 1755	-73.14	19.70	2.7-10.3	17-30	17-30	92.84	100		

Maximum Gain/Maximum Power (Mobile Unit)										
Band	Frequency Range (MHz)	Input Power (dBm)	Output Power (dBm)	Antenna Gain (dB)	EIRP (dBm)	EIRP Limit (dBm)	Gain (dB)	Gain Limit* (dB)	UL vs DL Gain	UL vs DL Gain Limit (dB)
WCDMA Band 2 Downlink	1930 - 1990	-55.92	8.98	<8.02	<17	<17	64.9	84.98	0.37	9
WCDMA Band 2 Uplink	1850 - 1910	-43.35	19.81	2.81-10.19	17-30	17-30	63.16	84.98		
WCDMA Band 5 Downlink	869 - 894	-48.98	8.47	<8.53	<17	<17	57.45	77.95	0.46	9
WCDMA Band 5 Uplink	824 - 849	-37.95	20.06	3.06-9.94	17-30	17-30	58.01	77.95		
LTE Band 2 Downlink	1930 - 1990	-56.86	8.18	<8.82	<17	<17	65.04	84.98	0.37	9
LTE Band 2 Uplink	1850 - 1910	-43.28	19.21	2.21-10.79	17-30	17-30	62.49	84.98		
LTE Band 5 Downlink	869 - 894	-48.91	8.71	<8.29	<17	<17	57.62	77.95	0.45	9
LTE Band 5 Uplink	824 - 849	-37.87	20.33	3.33-9.67	17-30	17-30	58.2	77.95		
LTE Band 12 Downlink	729 - 746	-45.79	8.64	<8.36	<17	<17	54.43	76.49	0.37	9
LTE Band 12 Uplink	699 - 716	-37.87	20.64	3.64-9.36	17-30	17-30	58.51	76.49		
LTE Band 13 Downlink	746 - 756	-47.75	8.85	<8.15	<17	<17	56.6	77.36	0.23	9
LTE Band 13 Uplink	777 - 787	-36.95	20.82	3.82-9.18	17-30	17-30	57.77	77.36		
LTE Band 4 Downlink	2110 - 2200	-55.88	7.41	<9.59	<17	<17	63.29	84.27	1.81	9
LTE Band 4 Uplink	1710 - 1755	-44.45	19.90	2.9-10.1	17-30	17-30	64.35	84.27		

* $19.5 \text{ dB} + 20 \text{ Log (Frequency)}$, where Frequency is the uplink midband frequency of the supported spectrum bands in MHz

Maximum Gain/Maximum Power with Maximum Transmitter Input Level – Fix Unit								
Band	Frequency Range (MHz)	Input Power (dBm)	Output Power (dBm)	Antenna Gain (dB)	EIRP (dBm)	EIRP Limit (dBm)	Gain (dB)	Gain Limit (dB)
WCDMA Band 2 Downlink	1930 - 1990	-20	8.45	8.55	<17	<17	28.45	100
WCDMA Band 2 Uplink	1850 - 1910	0	19.35	2.35-10.65	17-30	17-30	19.35	100
WCDMA Band 5 Downlink	869 - 894	-20	8.35	8.65	<17	<17	28.35	100
WCDMA Band 5 Uplink	824 - 849	0	20.12	3.12-9.88	17-30	17-30	20.12	100
LTE Band 2 Downlink	1930 - 1990	-20	8.02	8.98	<17	<17	28.02	100
LTE Band 2 Uplink	1850 - 1910	0	19.01	2.01-10.99	17-30	17-30	19.01	100
LTE Band 5 Downlink	869 - 894	-20	8.24	8.76	<17	<17	28.24	100
LTE Band 5 Uplink	824 - 849	0	20.35	3.35-9.65	17-30	17-30	20.35	100
LTE Band 12 Downlink	729 - 746	-20	8.36	8.64	<17	<17	28.36	100
LTE Band 12 Uplink	699 - 716	0	20.22	3.22-9.78	17-30	17-30	20.22	100
LTE Band 13 Downlink	746 - 756	-20	8.37	8.63	<17	<17	28.37	100
LTE Band 13 Uplink	777 - 787	0	20.56	3.56-9.44	17-30	17-30	20.56	100
LTE Band 4 Downlink	2110 - 2200	-20	6.93	10.07	<17	<17	26.93	100
LTE Band 4 Uplink	1710 - 1755	0	19.66	2.66-10.34	17-30	17-30	19.66	100

Maximum Gain/Maximum Power with Maximum Transmitter Input Level – Mobile Unit								
Band	Frequency Range (MHz)	Input Power (dBm)	Output Power (dBm)	Antenna Gain (dB)	EIRP (dBm)	EIRP Limit (dBm)	Gain (dB)	Gain Limit* (dB)
WCDMA Band 2 Downlink	1930 - 1990	-20	8.90	8.1	<17	<17	28.9	84.98
WCDMA Band 2 Uplink	1850 - 1910	0	19.11	2.11-10.89	17-30	17-30	19.11	84.98
WCDMA Band 5 Downlink	869 - 894	-20	8.47	8.53	<17	<17	28.47	77.95
WCDMA Band 5 Uplink	824 - 849	0	20.04	3.04-9.96	17-30	17-30	20.04	77.95
LTE Band 2 Downlink	1930 - 1990	-20	8.15	8.85	<17	<17	28.15	84.98
LTE Band 2 Uplink	1850 - 1910	0	19.04	2.04-10.96	17-30	17-30	19.04	84.98
LTE Band 5 Downlink	869 - 894	-20	8.58	8.42	<17	<17	28.58	77.95
LTE Band 5 Uplink	824 - 849	0	20.33	3.33-9.67	17-30	17-30	20.33	77.95
LTE Band 12 Downlink	729 - 746	-20	8.47	8.53	<17	<17	28.47	76.49
LTE Band 12 Uplink	699 - 716	0	20.41	3.41-9.59	17-30	17-30	20.41	76.49
LTE Band 13 Downlink	746 - 756	-20	8.36	8.64	<17	<17	28.36	77.36
LTE Band 13 Uplink	777 - 787	0	20.58	3.58-9.42	17-30	17-30	20.58	77.36
LTE Band 4 Downlink	2110 - 2200	-20	7.42	9.58	<17	<17	27.42	84.27
LTE Band 4 Uplink	1710 - 1755	0	19.88	2.88-10.12	17-30	17-30	19.88	84.27

* $19.5 \text{ dB} + 20 \text{ Log (Frequency)}$, where Frequency is the uplink midband frequency of the supported spectrum bands in MHz

2.5 INTERMODULATION PRODUCT

2.5.1 Specification Reference

FCC 47 CFR Part 20. Clause 20.21(e)(9)(i)(G)
KDB935210 D04, Clause 7.4

2.5.2 Standard Applicable

FCC 47 CFR Part 20. Clause 20.21(e)(9)(i)(G) Intermodulation Limits:
The transmitted intermodulation products of a consumer booster at its uplink and downlink ports shall not exceed the power level of -19 dBm for the supported bands of operation. Compliance with intermodulation limits will use boosters operating at maximum gain and maximum rated output power, with two continuous wave (CW) input signals spaced 600 kHz apart and centered in the pass band of the booster, and with a 3 kHz measurement bandwidth.

2.5.3 Equipment Under Test and Modification State

Serial No: 332633000356 / Test Configuration F

2.5.4 Date of Test/Initial of test personnel who performed the test

January 20 and February 06, 2017/XYZ

2.5.5 Test Equipment Used

The major items of test equipment used for the above tests are identified in Section 3.1.

2.5.6 Environmental Conditions

Test performed at TÜV SÜD America Inc. Rancho Bernardo facility.

Ambient Temperature	20.8 - 24.0°C
Relative Humidity	41.0 - 49.5%
ATM Pressure	98.9 - 99.4kPa

2.5.7 Additional Observations

- 1) This is conducted Test. Test procedure is per Section 7.4 of KDB935210 (D04 Provider Specific Booster Measurements v02). Appropriate offset (line losses) applied.
- 2) The Fix Unit operated in Test Mode with the gain manually set to the maximum gain and a minimum bandwidth setting (5MHz).
- 3) Setup the EUT according to Figure 5 of Section 7.4 of KDB935210 (D04 Provider Specific Booster Measurements v02).
- 4) Evaluations are conducted at Server and Donor ports antenna ports.
- 5) Operational uplink and downlink bands for WCDMA Band 2, 5, and LTE Band 2, 5, 12, 13 and 4 were tested.

2.5.8 Test Results

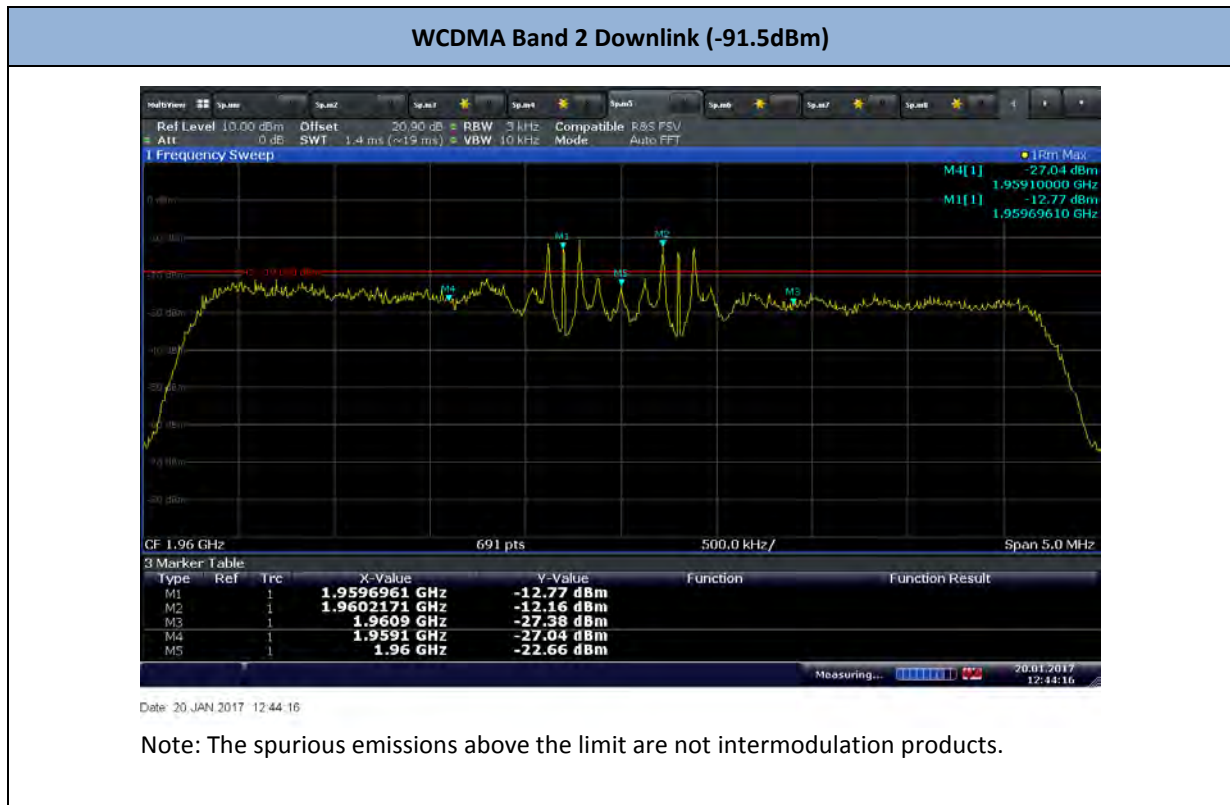

WCDMA Band 2 Downlink (-81.5dBm)

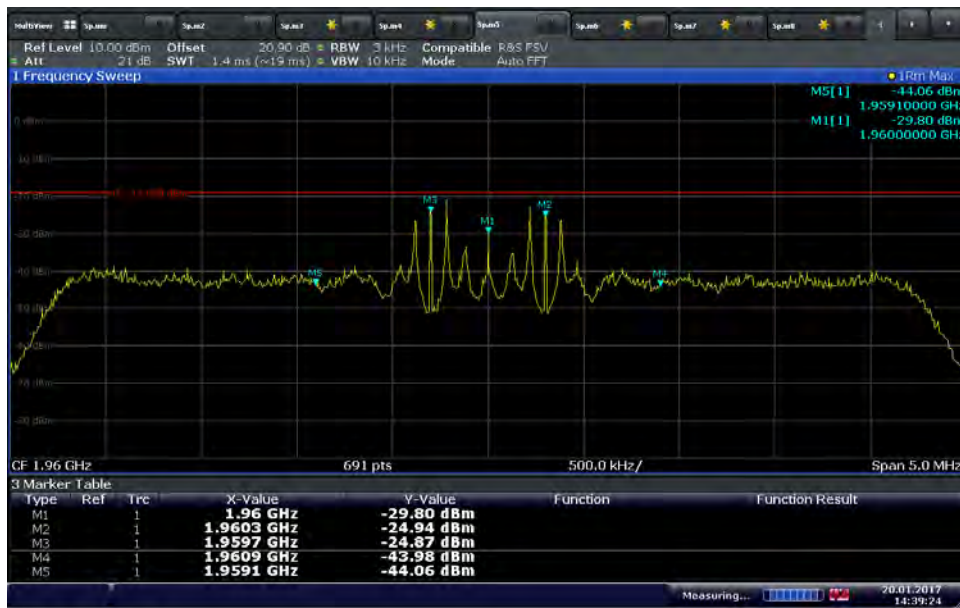

Date: 20 JAN 2017 14:39:24

WCDMA Band 2 Uplink (-90.2dBm)



Date: 6 FEB 2017 10:08:19

Note: The spurious emissions above the limit are not intermodulation products.

WCDMA Band 2 Uplink (-80.2dBm)

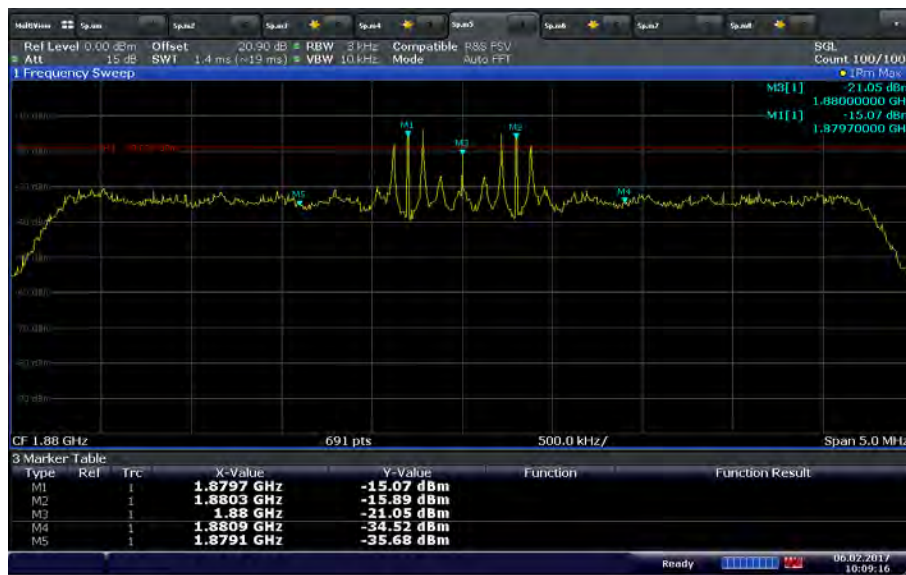

Date: 6 FEB 2017 10:08:16

Note: The spurious emissions above the limit are not intermodulation products.

WCDMA Band 5 Downlink (-95.0dBm)

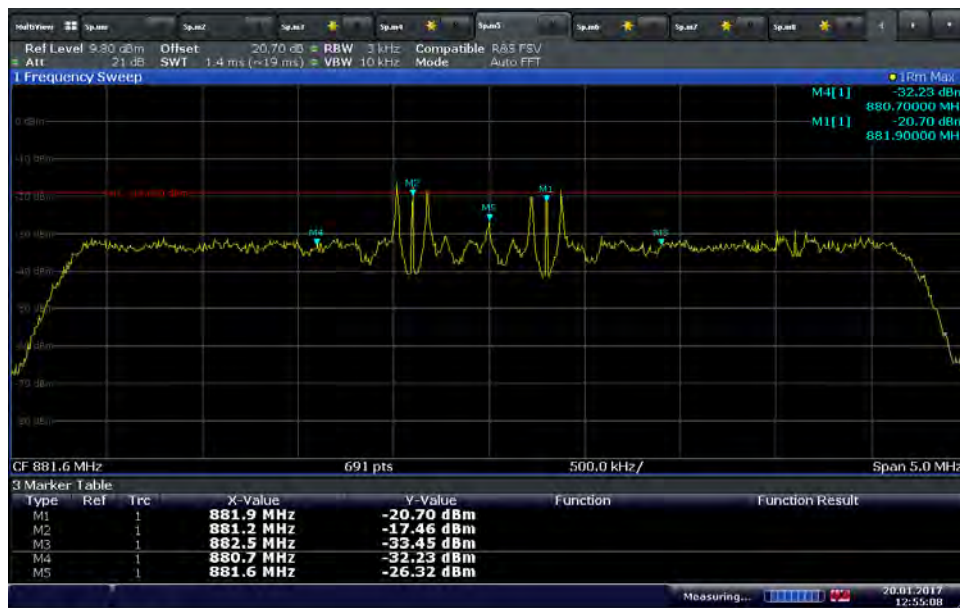

Date: 20 JAN 2017 12:55:08

Note: The spurious emissions above the limit are not intermodulation products.

WCDMA Band 5 Downlink (-85.0dBm)

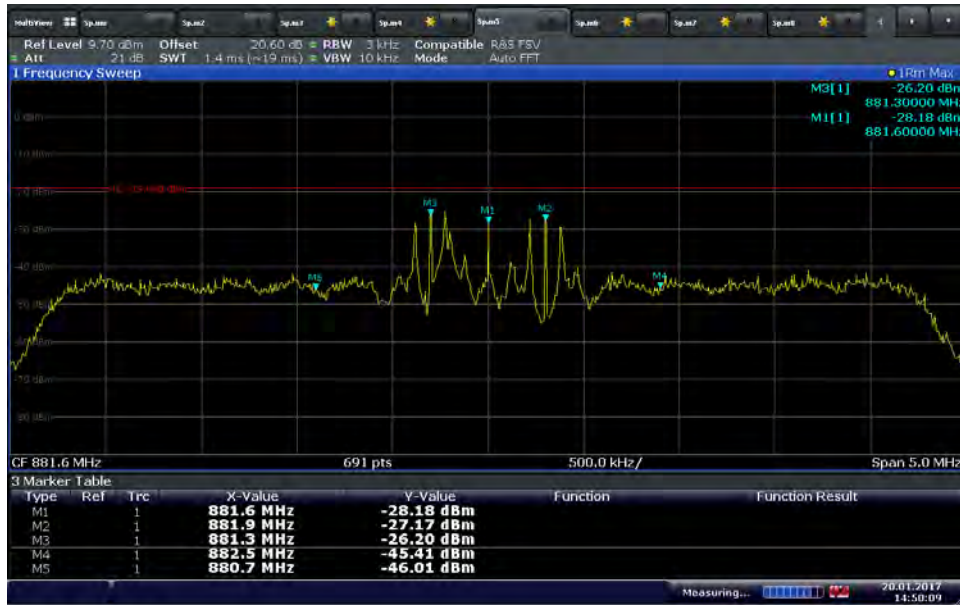

Date: 20 JAN 2017 14:50:10

WCDMA Band 5 Uplink (-91.0dBm)



Date: 20 JAN 2017 13:54:44

Note: The spurious emissions above the limit are not intermodulation products.

WCDMA Band 5 Uplink (-81.0dBm)

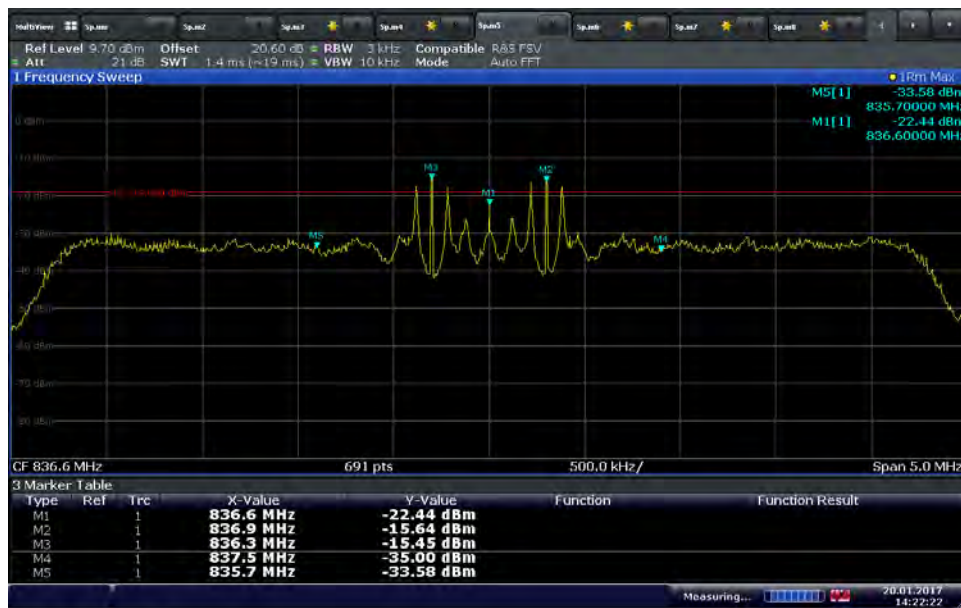

Date: 20 JAN 2017 14:22:22

Note: The spurious emissions above the limit are not intermodulation products.

LTE Band 2 Downlink (-84dBm)



Date: 20 JAN 2017 12:45:53

Note: The spurious emissions above the limit are not intermodulation products.

LTE Band 2 Downlink (-74dBm)

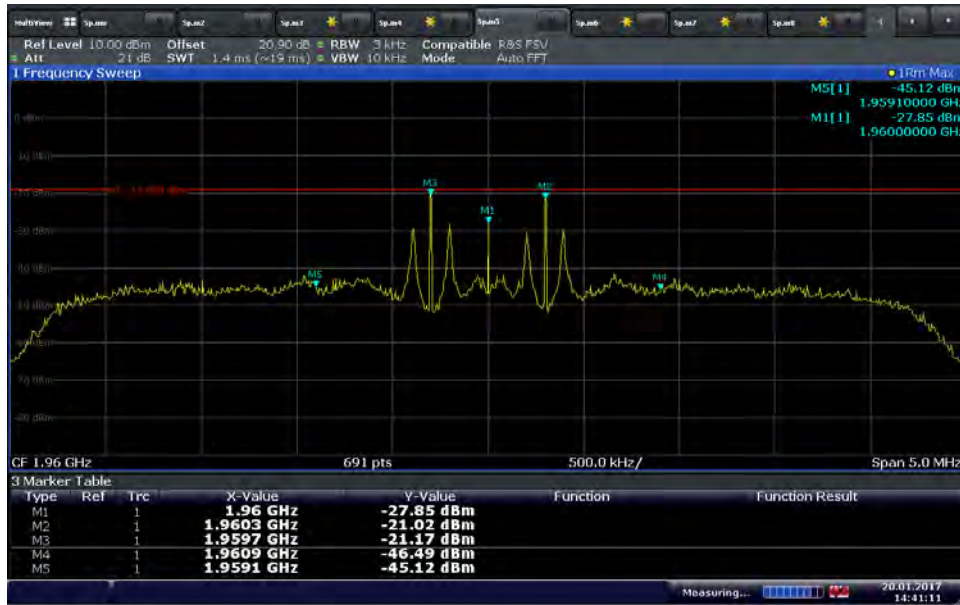

Date: 20.JAN.2017 14:41:11

LTE Band 2 Uplink (-86.3dBm)

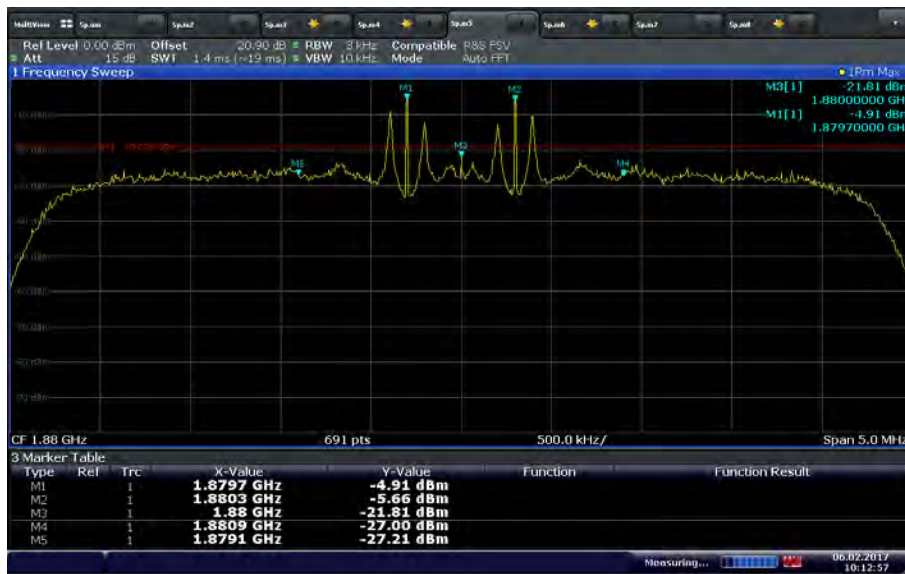

Date: 6 FEB 2017 10:12:57

Note: The spurious emissions above the limit are not intermodulation products.

LTE Band 2 Uplink (-76.3dBm)

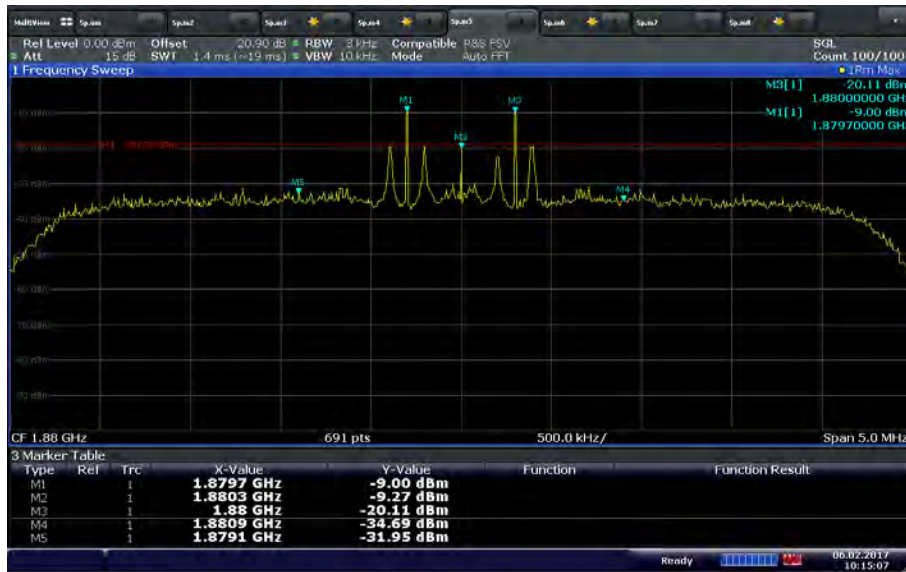

Date: 6 FEB 2017 10:15:08

LTE Band 5 Downlink (-85.4dBm)



Date: 20 JAN 2017 12:51:40

Note: The spurious emissions above the limit are not intermodulation products.

LTE Band 5 Downlink (-75.4dBm)

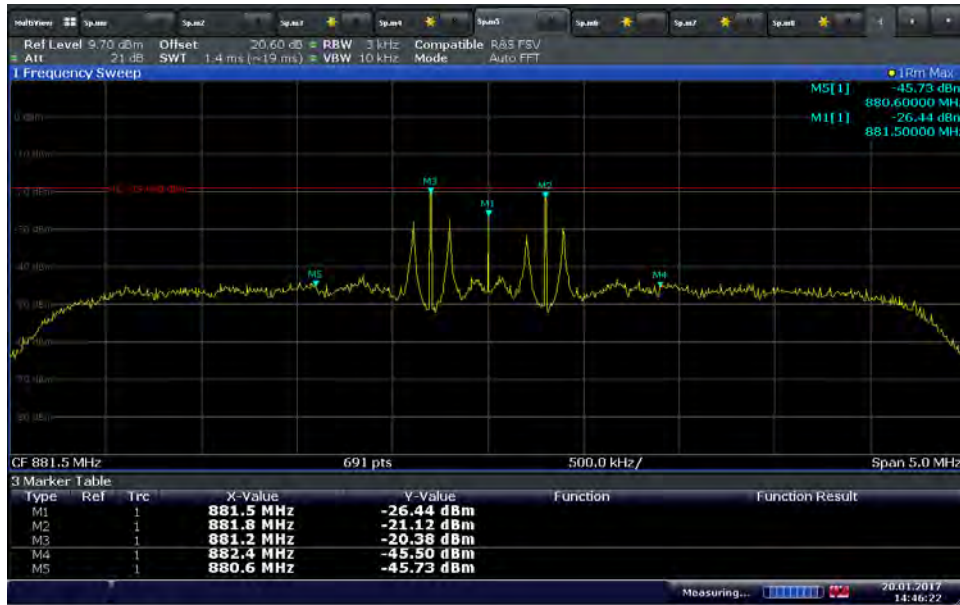

Date: 20 JAN 2017 14:46:23

LTE Band 5 Uplink (-85dBm)

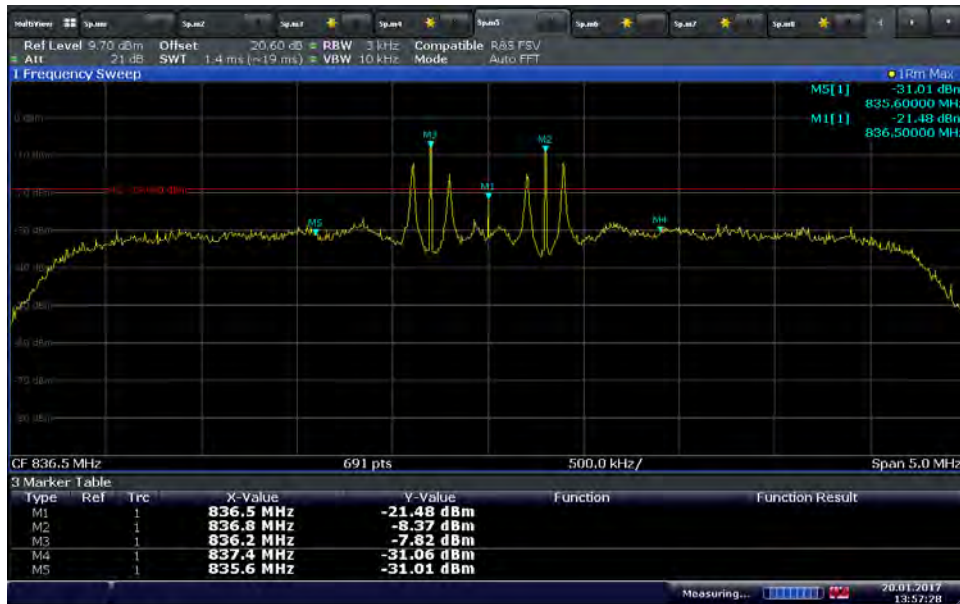

Date: 20 JAN 2017 13:57:28

Note: The spurious emissions above the limit are not intermodulation products.

LTE Band 5 Uplink (-75dBm)



Date: 20 JAN 2017 14:19:45

Note: The spurious emissions above the limit are not intermodulation products.

LTE Band 12 Downlink (-86dBm)



Date: 20 JAN 2017 12:58:27

Note: The spurious emissions above the limit are not intermodulation products.

LTE Band 12 Downlink (-76dBm)

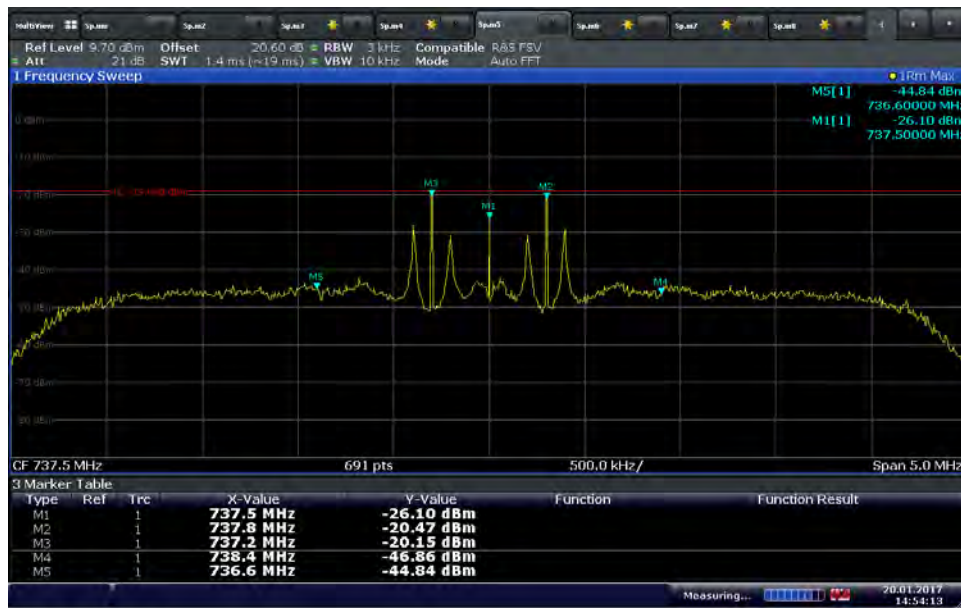

LTE Band 12 Uplink (-85.5dBm)

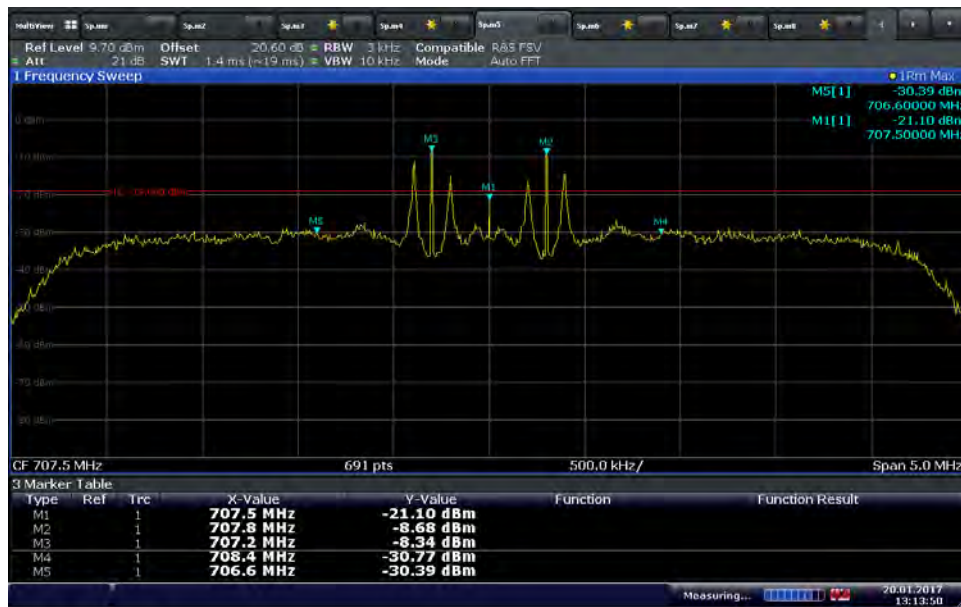

Note: The spurious emissions above the limit are not intermodulation products.

LTE Band 12 Uplink (-75.5dBm)

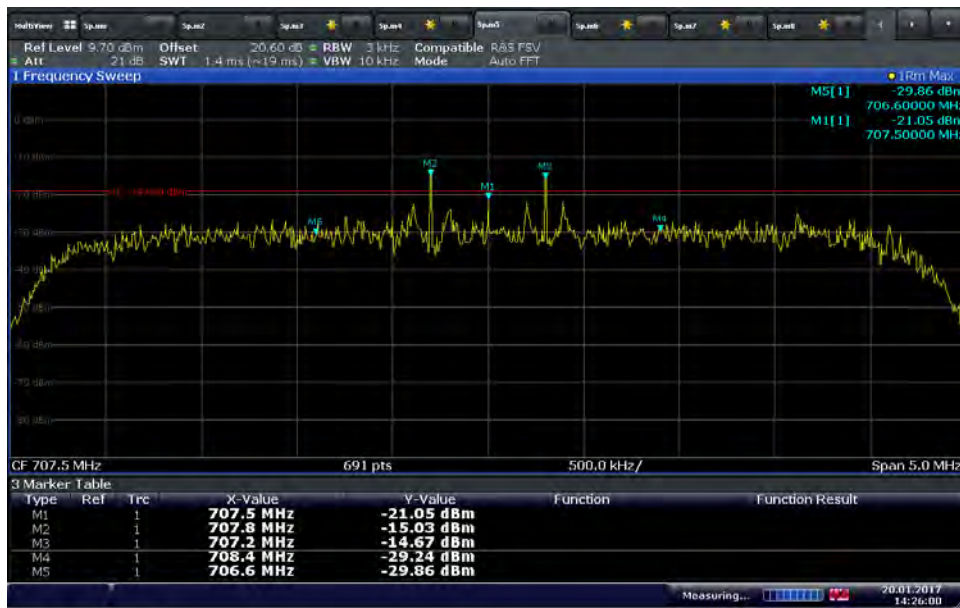

Date: 20.JAN.2017 14:26:00

LTE Band 13 Downlink (-86dBm)



Date: 20.JAN.2017 13:00:11

Note: The spurious emissions above the limit are not intermodulation products.

LTE Band 13 Downlink (-76dBm)



Date: 20 JAN 2017 14:56:23

LTE Band 13 Uplink (-85.5dBm)



Date: 20 JAN 2017 13:16:08

Note: The spurious emissions above the limit are not intermodulation products.

LTE Band 13 Uplink (-75.5dBm)



Date: 20. JAN 2017 14:28:28

Note: The spurious emissions above the limit are not intermodulation products.

LTE Band 4 Downlink (-85.5dBm)

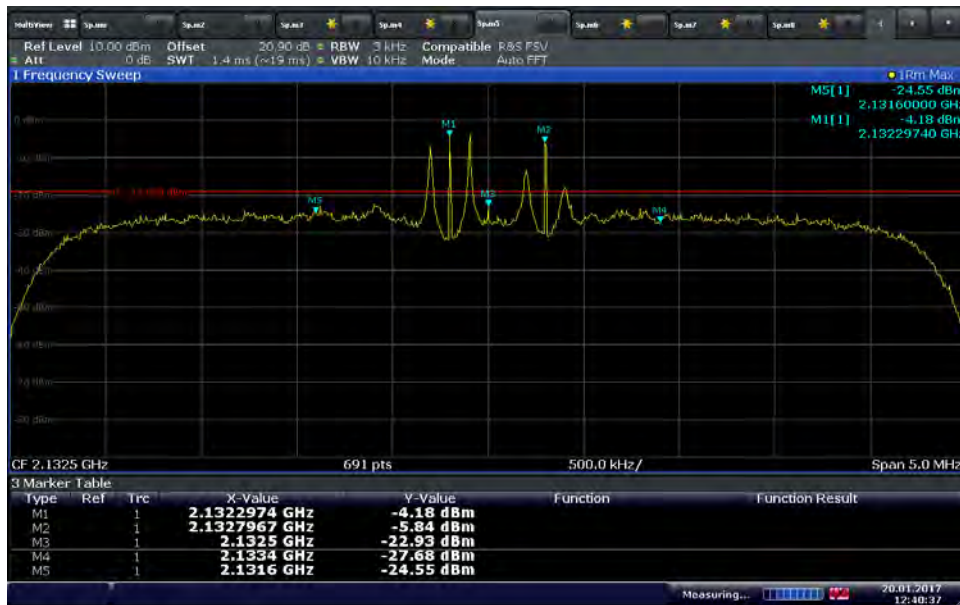

Date: 20. JAN 2017 12:40:37

Note: The spurious emissions above the limit are not intermodulation products.

LTE Band 4 Downlink (-75.5dBm)

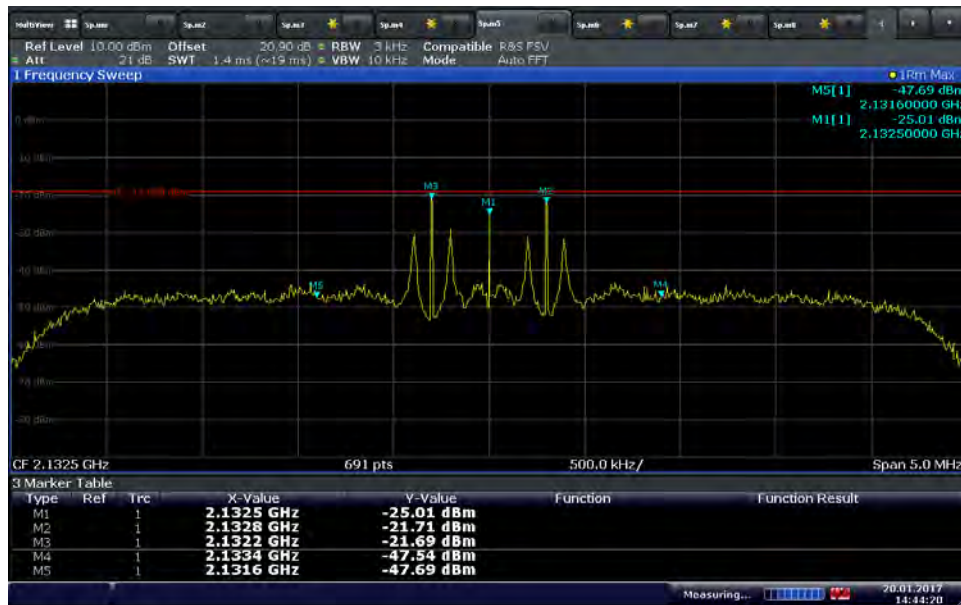

Date: 20 JAN 2017 14:44:20

LTE Band 4 Uplink (-86.1dBm)

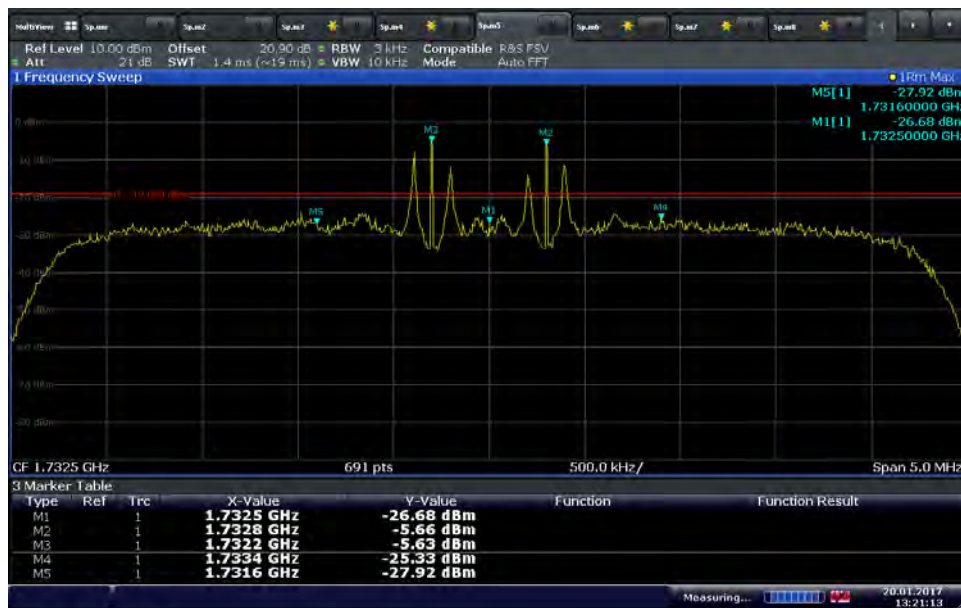

Date: 20 JAN 2017 13:21:13

Note: The spurious emissions above the limit are not intermodulation products.

LTE Band 4 Uplink (-76.1dBm)

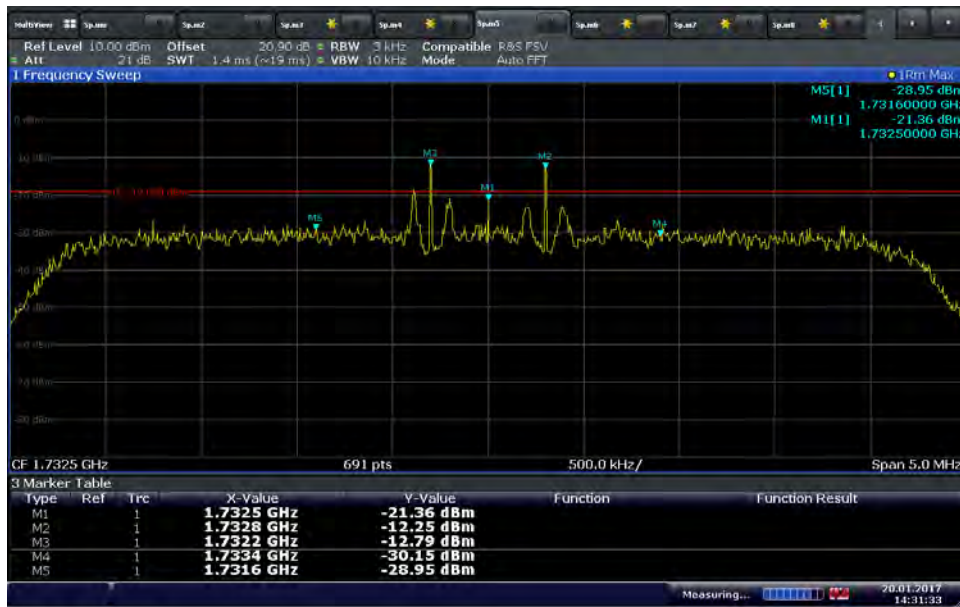

Date: 20 JAN 2017 14:31:33

Note: The spurious emissions above the limit are not intermodulation products.

2.6 OUT OF BAND EMISSIONS

2.6.1 Specification Reference

FCC 47 CFR Part 20. Clause 20.21(e)(9)(i)(F)
KDB935210 D04, Clause 7.5

2.6.2 Standard Applicable

FCC 47 CFR Part 20. Clause 20.21(e)(9)(i)(F) Out of Band Emissions Limits:
Booster out of band emissions (OOBE) shall meet the FCC's mobile emission limits for the supported bands of operation. Compliance to OOBE limits will utilize high peak-to-average CMRS signal types..

2.6.3 Equipment Under Test and Modification State

Serial No: 332633000356 / Test Configuration A and B

2.6.4 Date of Test/Initial of test personnel who performed the test

December 22, 2016/XYZ

2.6.5 Test Equipment Used

The major items of test equipment used for the above tests are identified in Section 3.1.

2.6.6 Environmental Conditions

Test performed at TÜV SÜD America Inc. Rancho Bernardo facility.

Ambient Temperature	22.7°C
Relative Humidity	56.6%
ATM Pressure	98.7kPa

2.6.7 Additional Observations

- 1) This is conducted Test. Test procedure is per Section 7.5 of KDB935210 (D04 Provider Specific Booster Measurements v02). Appropriate offset (line losses) applied.
- 2) The Fix Unit operated in Test Mode, with the gain manually set to the maximum gain and a minimum bandwidth setting (5MHz).
- 3) Setup the EUT according to Figure 1 or 2 of Section 7.7 of KDB935210 (D04 Provider Specific Booster
- 4) Evaluations are conducted at Server and Donor antenna ports.
- 5) Operational uplink and downlink bands for WCDMA Band 2, 5, and LTE Band 2, 5, 12, 13, and 4 were tested.
- 6) Signal: 5MHz LTE or WCDMA.

2.6.8 Test Results

WCDMA Band 2 Downlink 5MHz Bandwidth Low Channel (-80 dBm)



Date: 22 DEC 2016 14:45:25

WCDMA Band 2 Downlink 5MHz Bandwidth Low Channel (-20 dBm)



Date: 22 DEC 2016 14:44:51

WCDMA Band 2 Downlink 5MHz Bandwidth High Channel (-80 dBm)

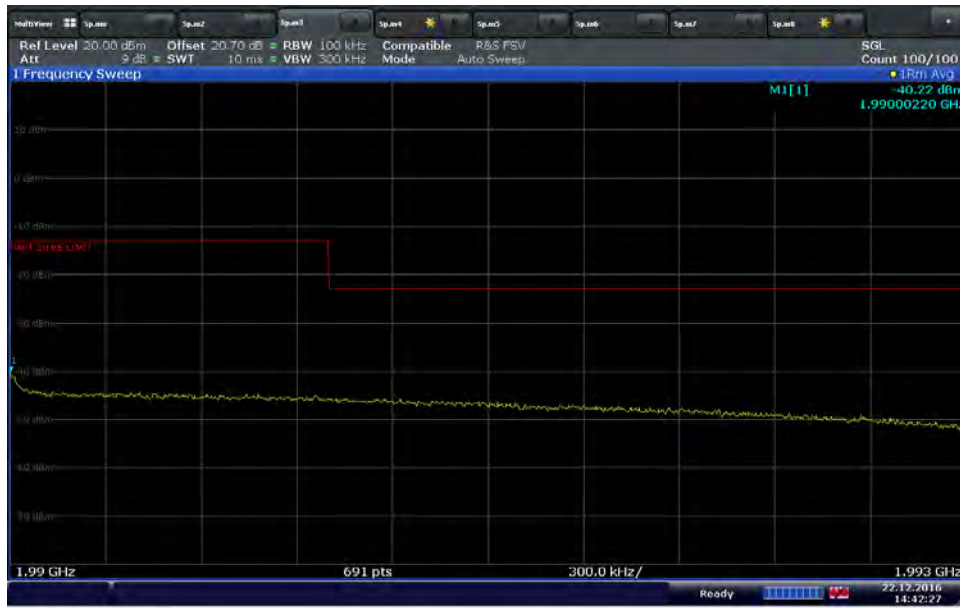

Date: 22 DEC 2016 14:42:27

WCDMA Band 2 Downlink 5MHz Bandwidth High Channel (-20 dBm)



Date: 22 DEC 2016 14:40:59

LTE Band 2 Downlink 5MHz Bandwidth Low Channel (-80 dBm)



Date: 22 DEC 2016 14:36:07

LTE Band 2 Downlink 5MHz Bandwidth Low Channel (-20 dBm)



Date: 22 DEC 2016 14:36:37

LTE Band 2 Downlink 5MHz Bandwidth High Channel (-80 dBm)



Date: 22 DEC 2016 14:43:07

LTE Band 2 Downlink 5MHz Bandwidth High Channel (-20 dBm)



Date: 22 DEC 2016 14:43:31

WCDMA Band 5 Downlink 5MHz Bandwidth Low Channel (-80 dBm)



Date: 22 DEC 2016 14:54:07

WCDMA Band 5 Downlink 5MHz Bandwidth Low Channel (-20 dBm)



Date: 22 DEC 2016 14:54:46

LTE Band 5 Downlink 5MHz Bandwidth High Channel (-80 dBm)

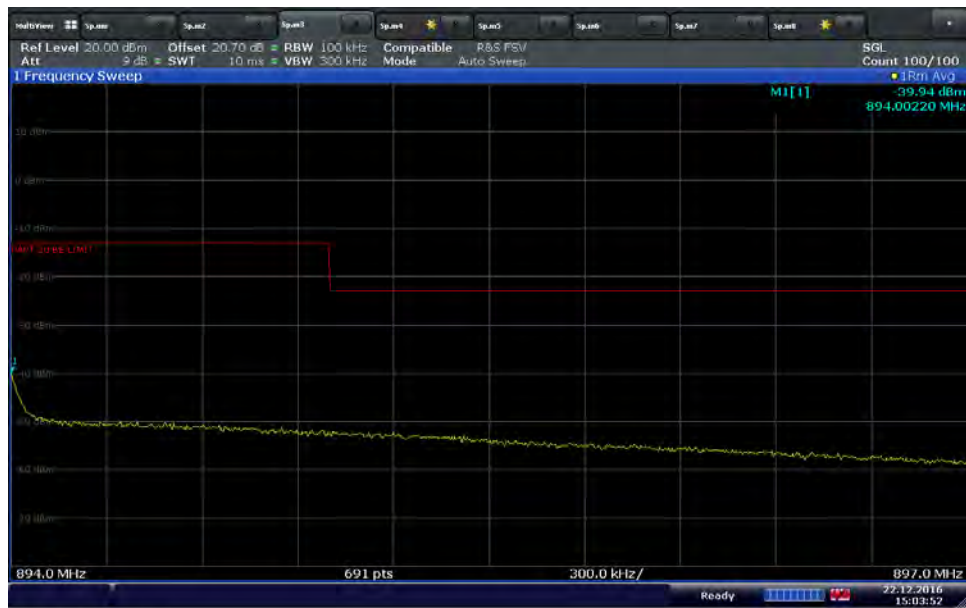

Date: 22 DEC 2016 15:03:53

LTE Band 5 Downlink 5MHz Bandwidth High Channel (-20 dBm)



Date: 22 DEC 2016 15:03:23

LTE Band 5 Downlink 5MHz Bandwidth Low Channel (-80 dBm)

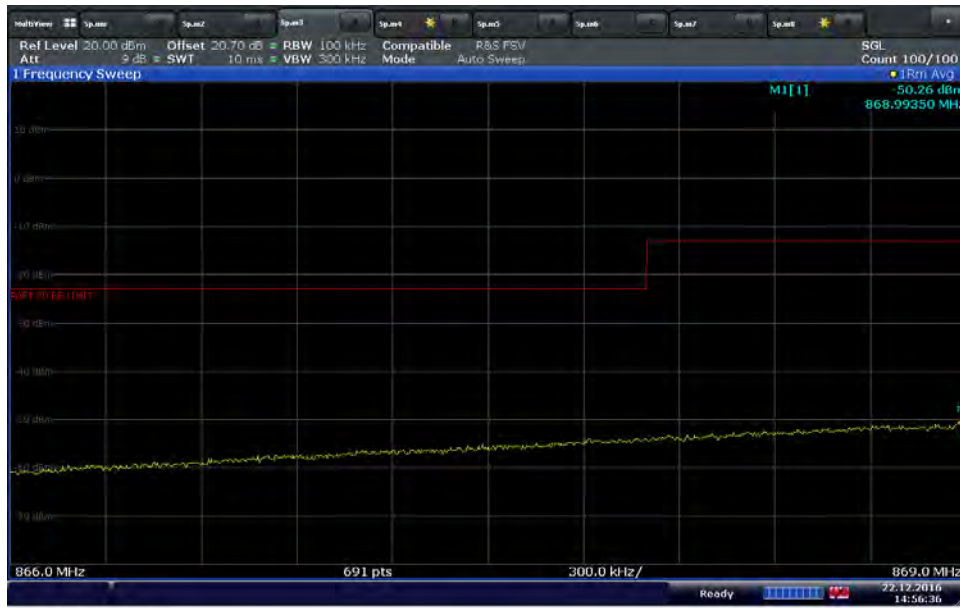

Date: 22 DEC 2016 14:56:37

LTE Band 5 Downlink 5MHz Bandwidth Low Channel (-20 dBm)



Date: 22 DEC 2016 14:54:46

LTE Band 5 Downlink 5MHz Bandwidth High Channel (-80 dBm)

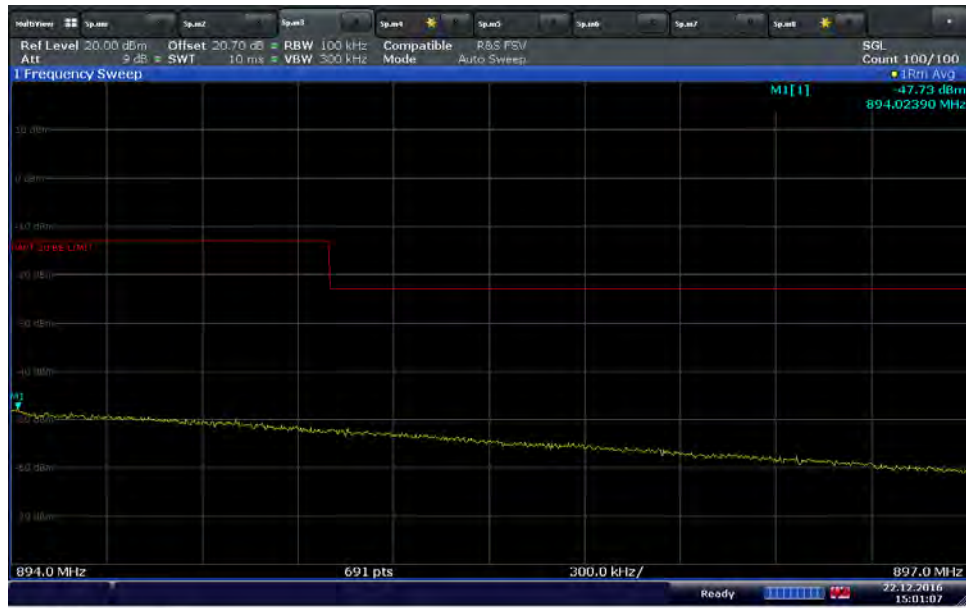

Date: 22 DEC 2016 15:01:07

LTE Band 5 Downlink 5MHz Bandwidth High Channel (-20 dBm)



Date: 22 DEC 2016 15:01:41

LTE Band 12 Downlink 5MHz Bandwidth Low Channel (-80 dBm)

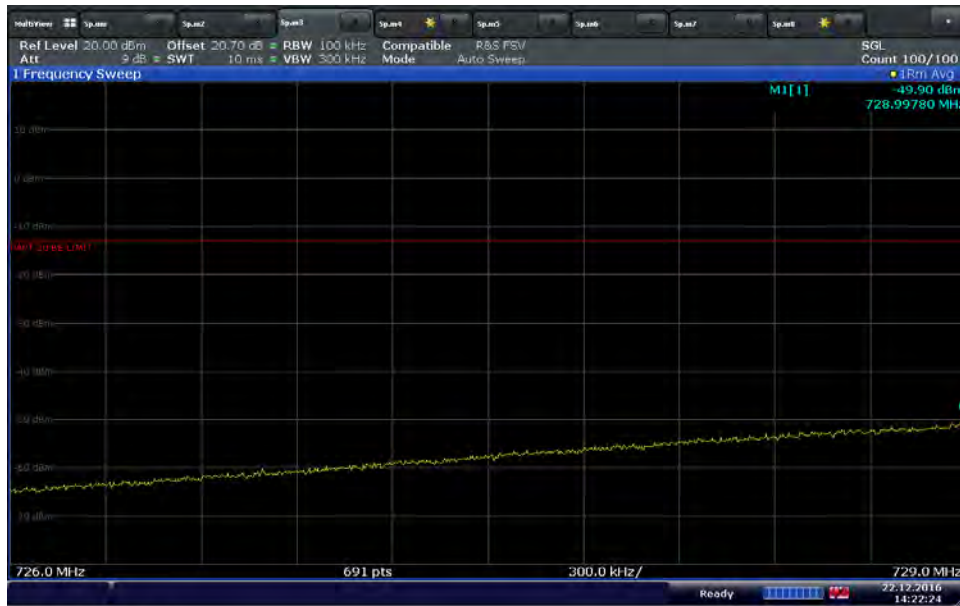

Date: 22 DEC 2016 14:22:24

LTE Band 12 Downlink 5MHz Bandwidth Low Channel (-20 dBm)



Date: 22 DEC 2016 14:36:37

LTE Band 12 Downlink 5MHz Bandwidth High Channel (-80 dBm)

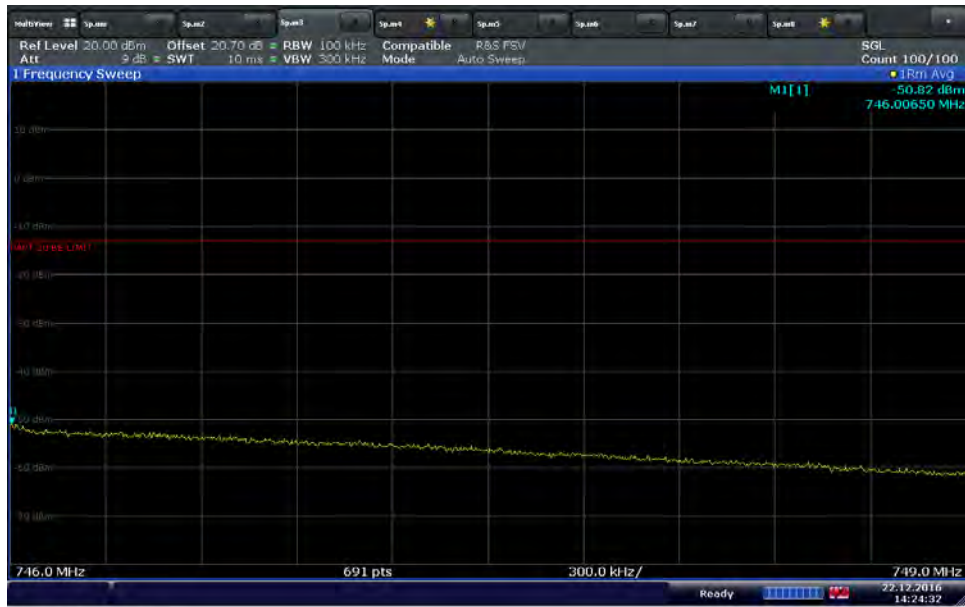

Date: 22 DEC 2016 14:24:32

LTE Band 12 Downlink 5MHz Bandwidth High Channel (-20 dBm)

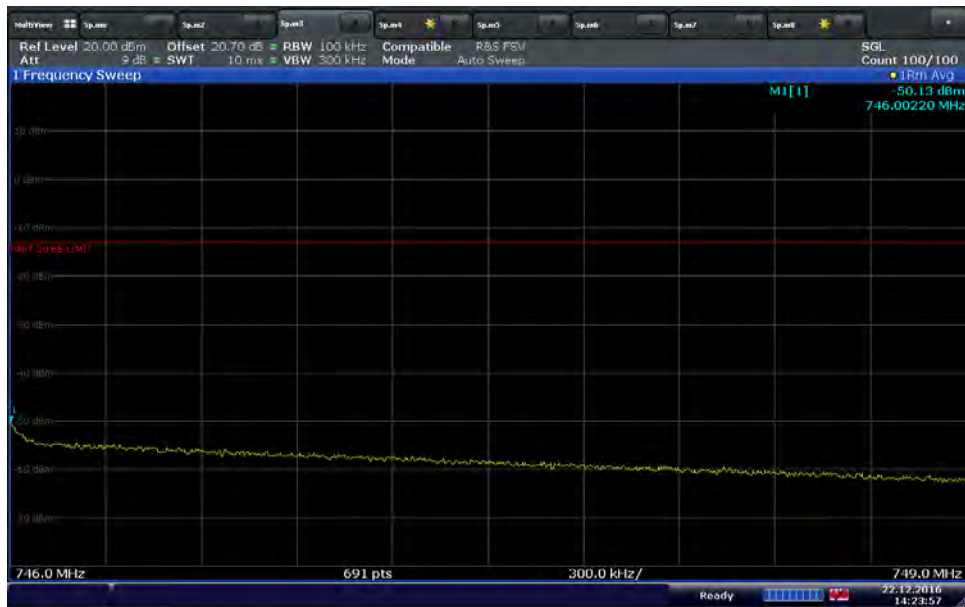

Date: 22 DEC 2016 14:23:58

LTE Band 13 Downlink 5MHz Bandwidth Low Channel (-83 dBm)

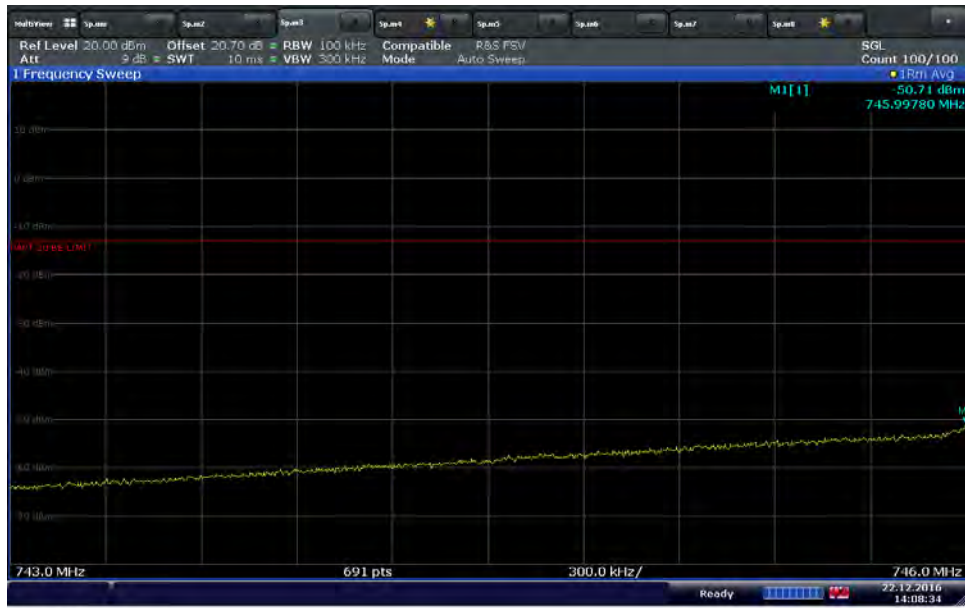

Date: 22 DEC 2016 14:08:33

LTE Band 13 Downlink 5MHz Bandwidth Low Channel (-20 dBm)

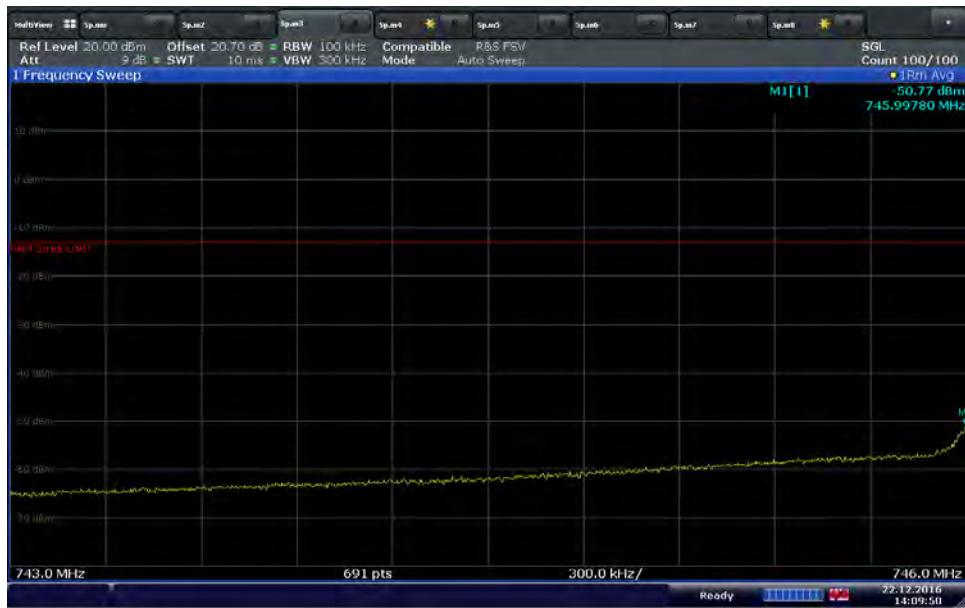

Date: 22 DEC 2016 14:09:50

LTE Band 13 Downlink 5MHz Bandwidth High Channel (-83 dBm)

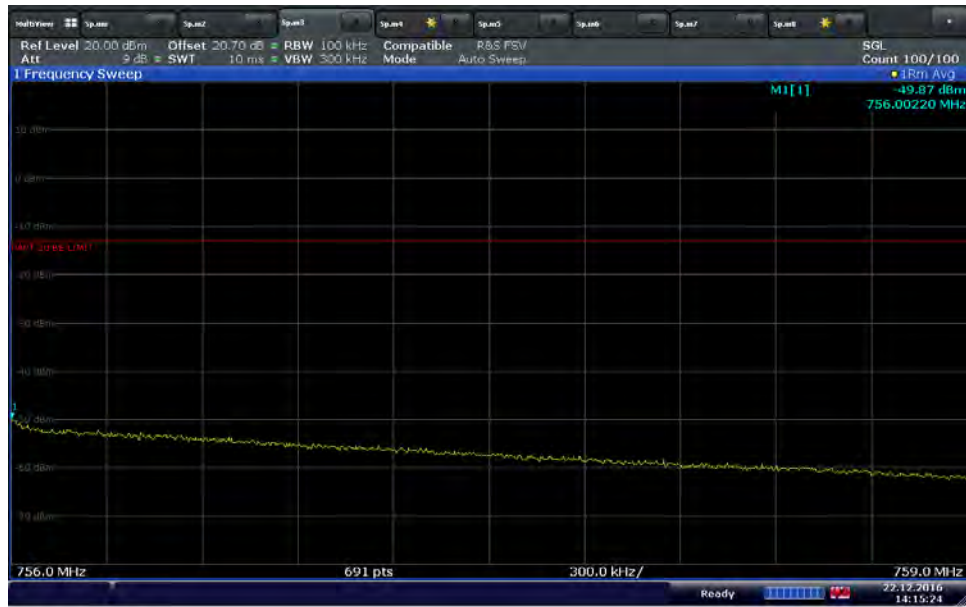

Date: 22 DEC 2016 14:15:24

LTE Band 13 Downlink 5MHz Bandwidth High Channel (-20 dBm)

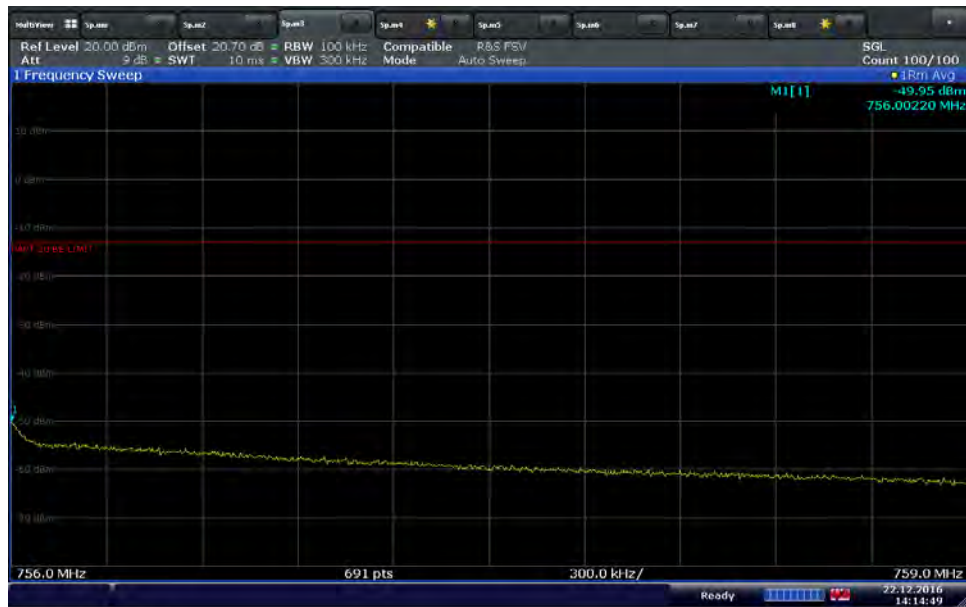

Date: 22 DEC 2016 14:14:49

LTE Band 4 Downlink 5MHz Bandwidth Low Channel (-80 dBm)

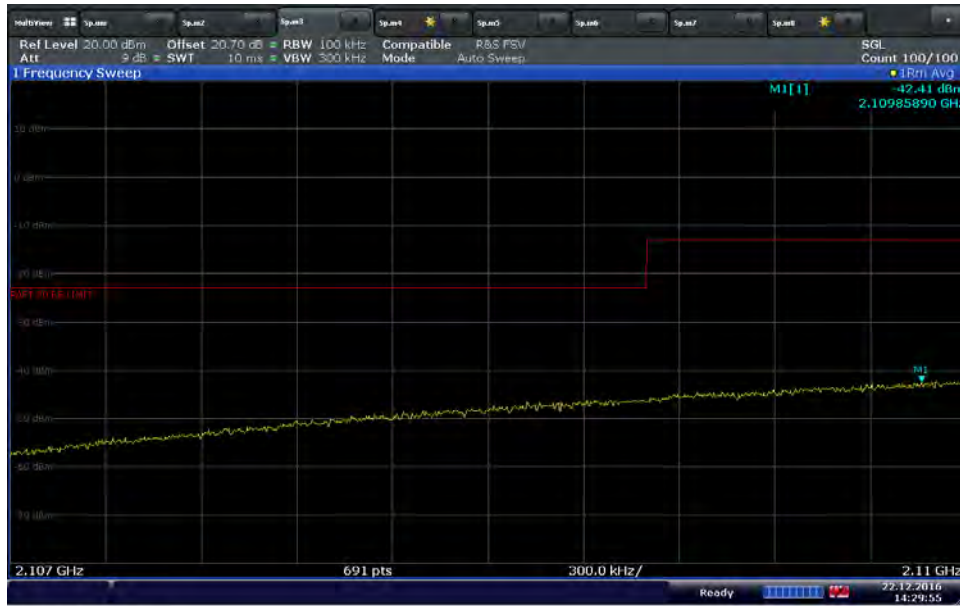

Date: 22 DEC 2016 14:29:55

LTE Band 4 Downlink 5MHz Bandwidth Low Channel (-20 dBm)



Date: 22 DEC 2016 14:30:20

LTE Band 4 Downlink 5MHz Bandwidth High Channel (-80 dBm)

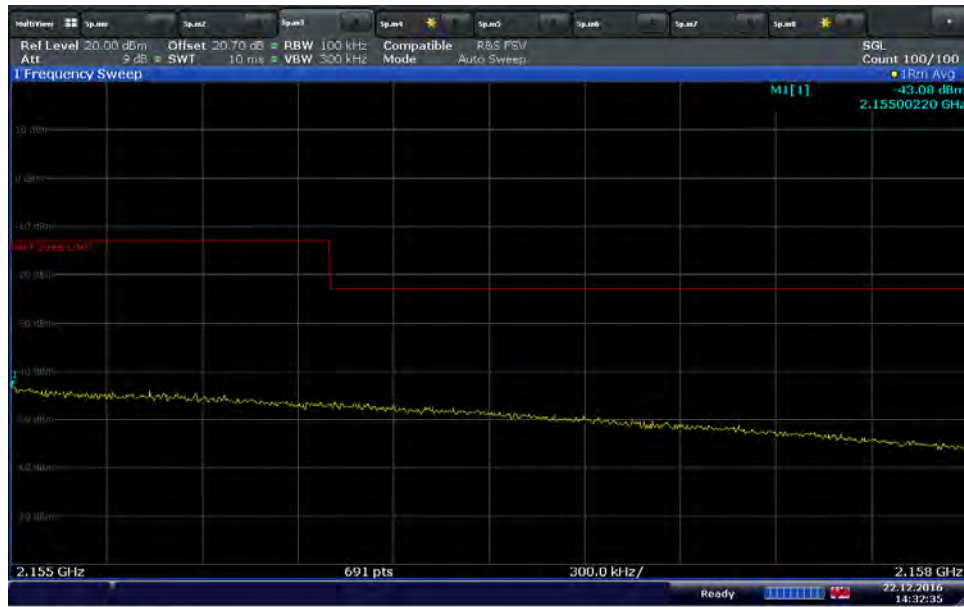

Date: 22 DEC 2016 14:32:35

LTE Band 4 Downlink 5MHz Bandwidth High Channel (-20 dBm)



Date: 22 DEC 2016 14:31:57

WCDMA Band 2 Uplink 5MHz Bandwidth Low Channel (-76 dBm)

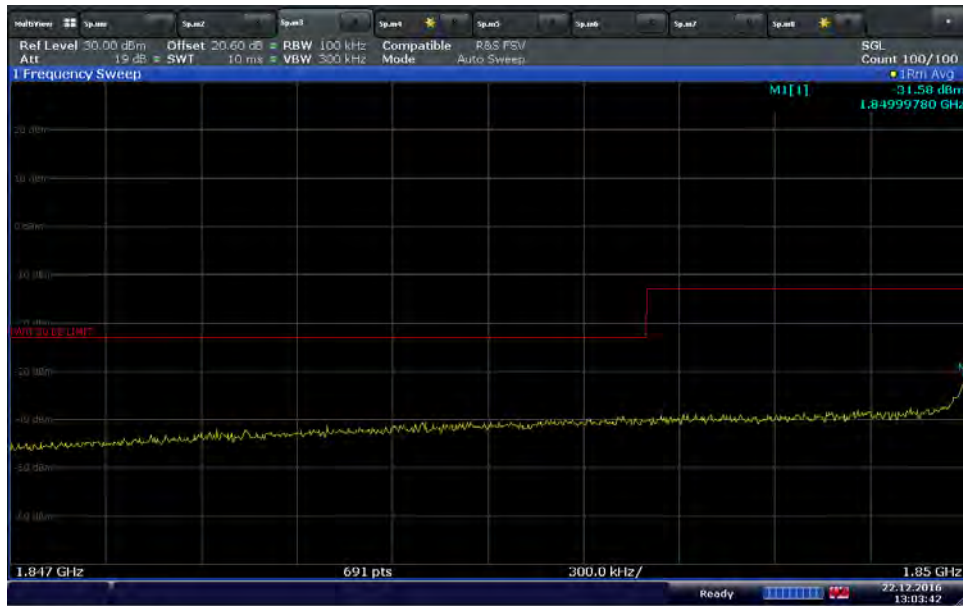

Date: 22 DEC 2016 13:03:42

WCDMA Band 2 Uplink 5MHz Bandwidth Low Channel (0 dBm)

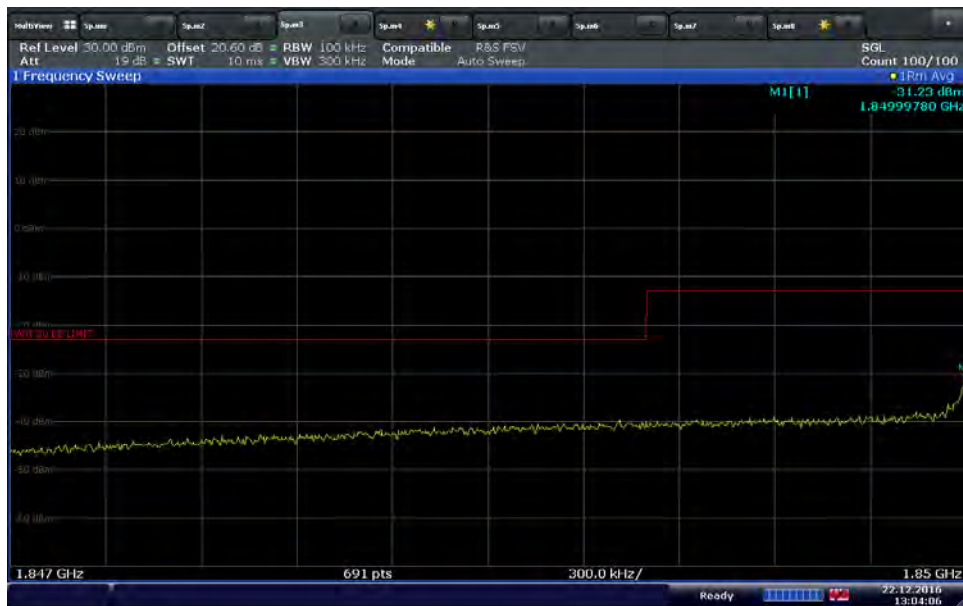

Date: 22 DEC 2016 13:04:06

WCDMA Band 2 Uplink 5MHz Bandwidth High Channel (-76 dBm)

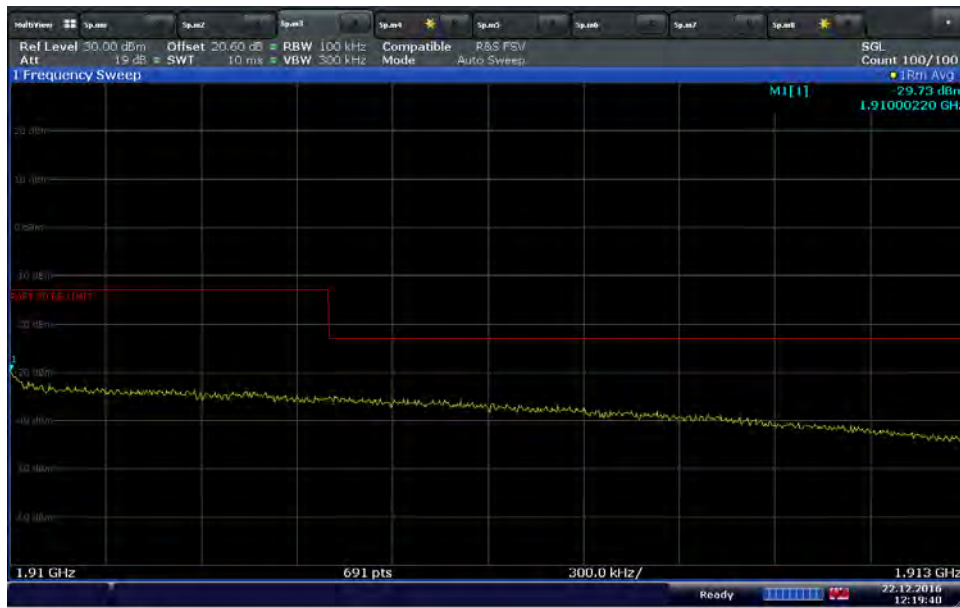

Date: 22 DEC 2016 12:19:40

WCDMA Band 2 Uplink 5MHz Bandwidth High Channel (0 dBm)

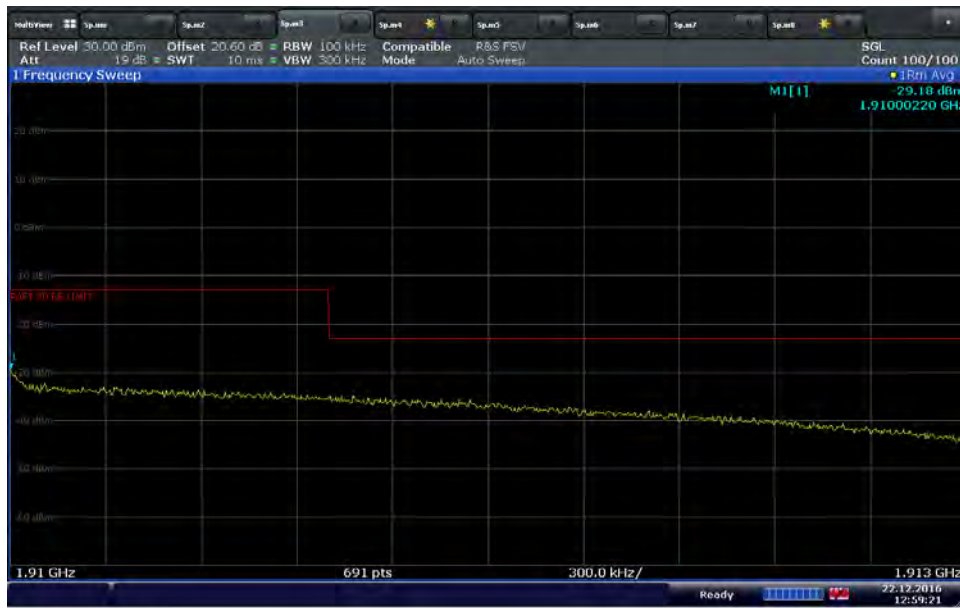

Date: 22 DEC 2016 12:59:22

LTE Band 2 Uplink 5MHz Bandwidth Low Channel (-71 dBm)

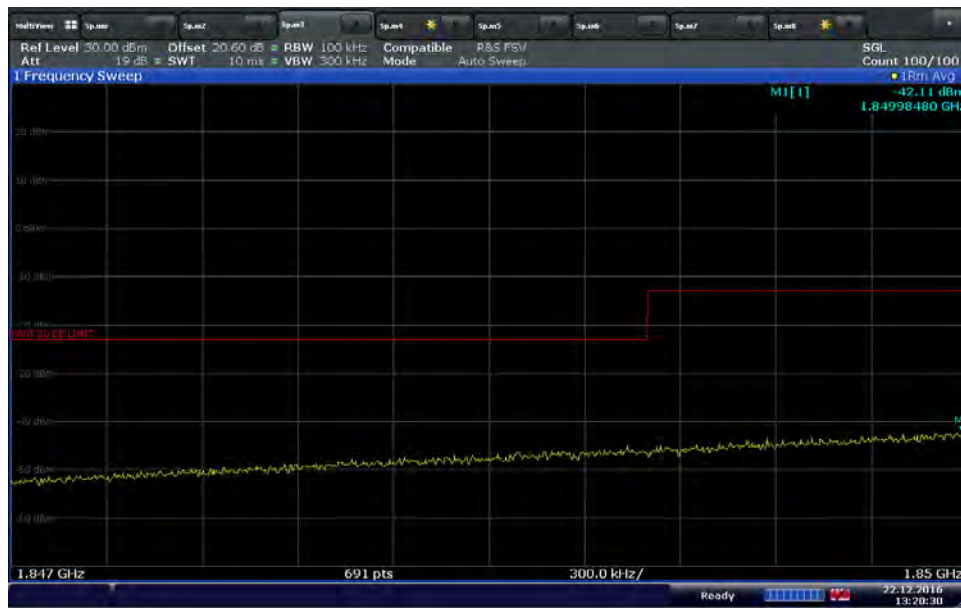

Date: 22 DEC 2016 13:20:30

LTE Band 2 Uplink 5MHz Bandwidth Low Channel (0 dBm)



Date: 22 DEC 2016 13:19:19

LTE Band 2 Uplink 5MHz Bandwidth High Channel (-71 dBm)

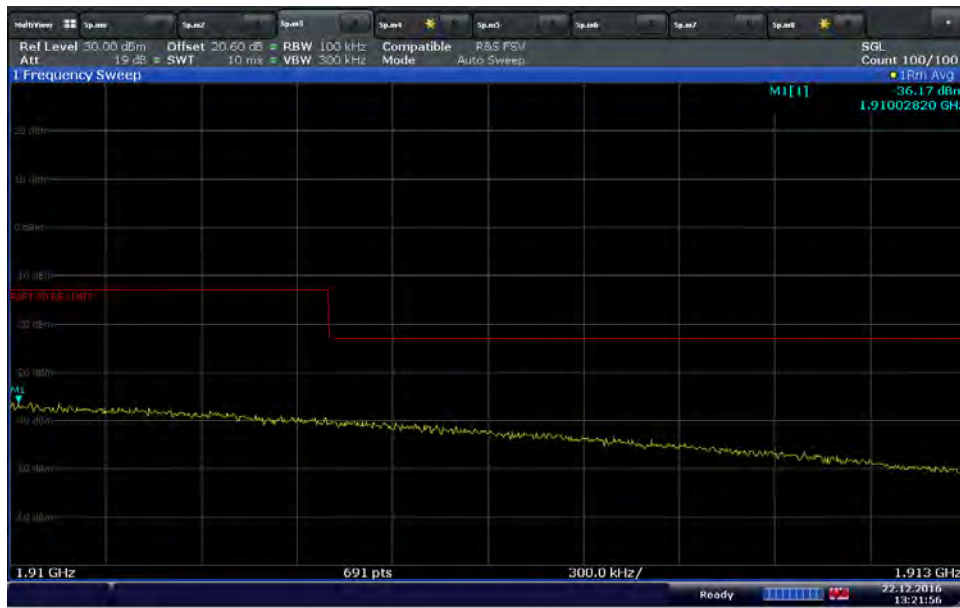

Date: 22.DEC 2016 13:21:56

LTE Band 2 Uplink 5MHz Bandwidth High Channel (0 dBm)

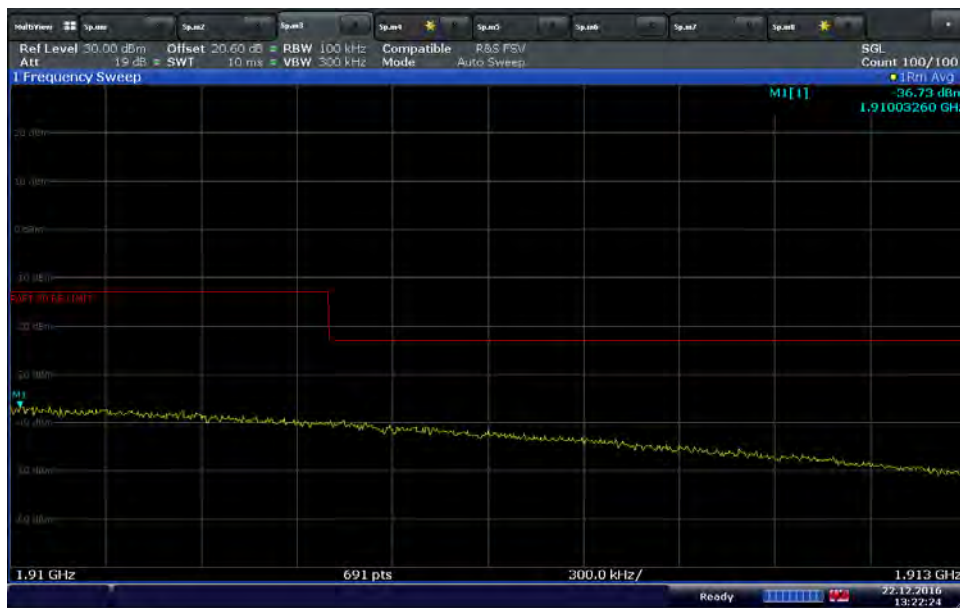

Date: 22.DEC 2016 13:22:24

WCDMA Band 5 Uplink 5MHz Bandwidth Low Channel (-76 dBm)

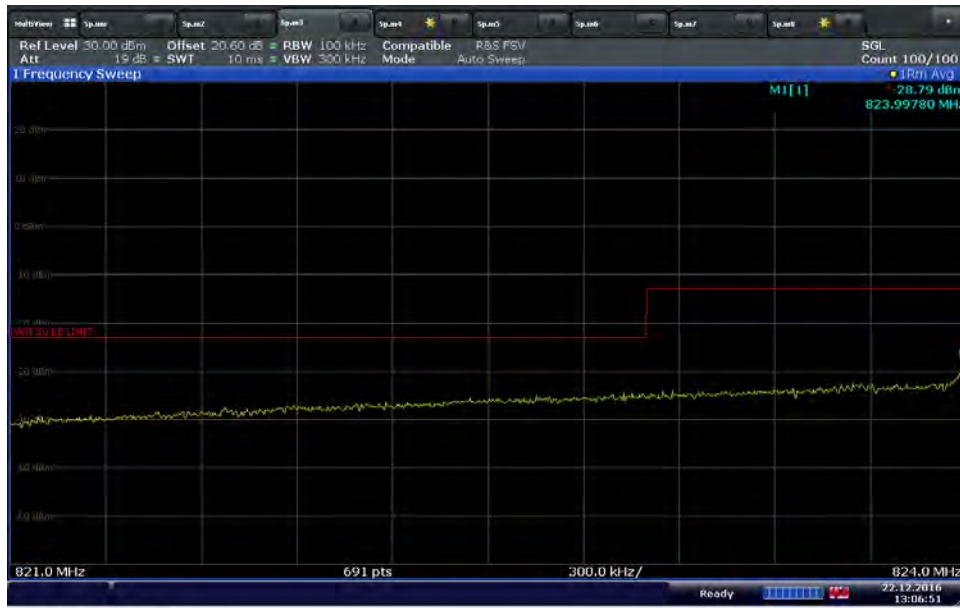

Date: 22 DEC 2016 13:06:51

WCDMA Band 5 Uplink 5MHz Bandwidth Low Channel (0 dBm)

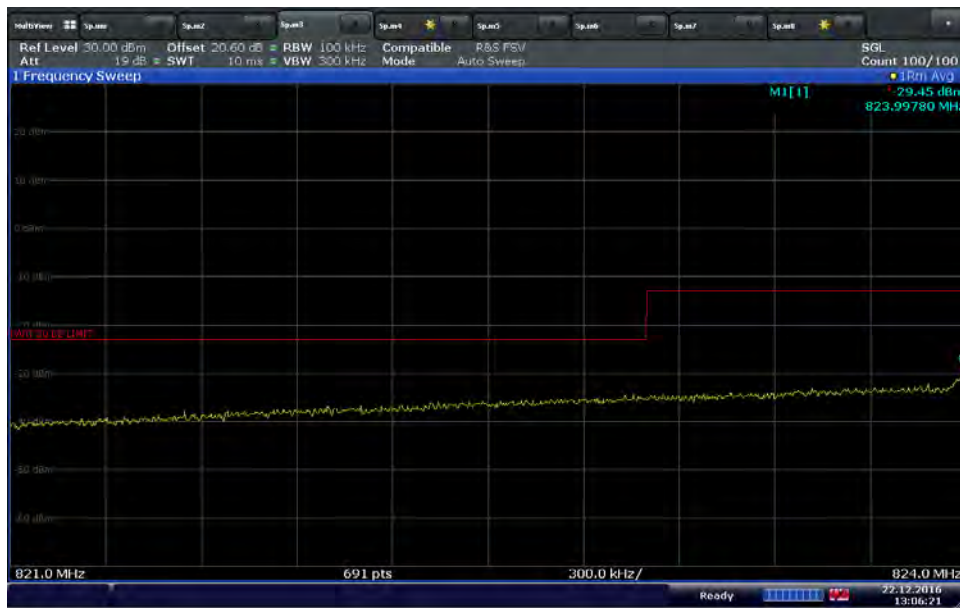

Date: 22 DEC 2016 13:06:21

WCDMA Band 5 Uplink 5MHz Bandwidth High Channel (-76 dBm)

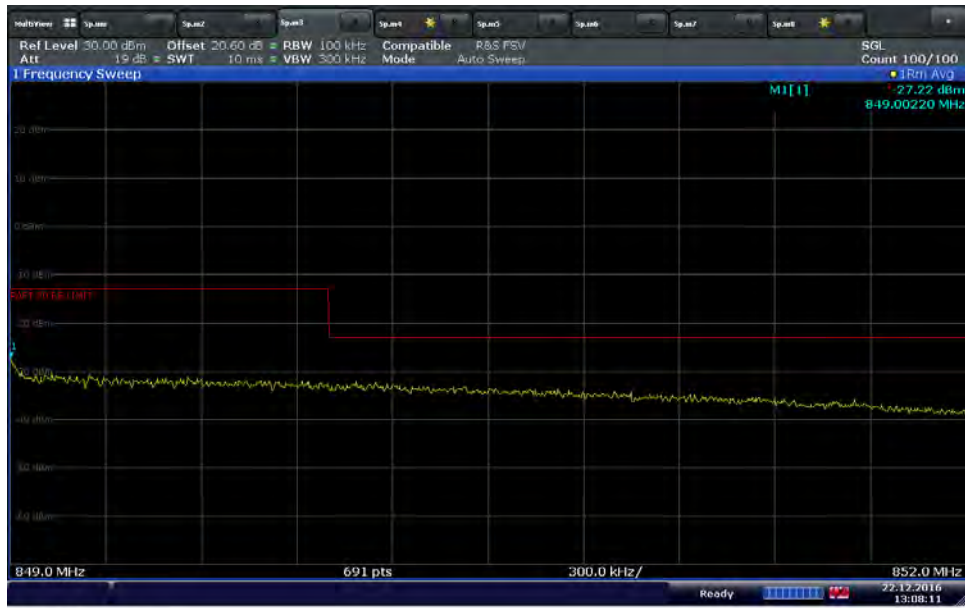

Date: 22 DEC 2016 13:08:10

WCDMA Band 5 Uplink 5MHz Bandwidth High Channel (0 dBm)

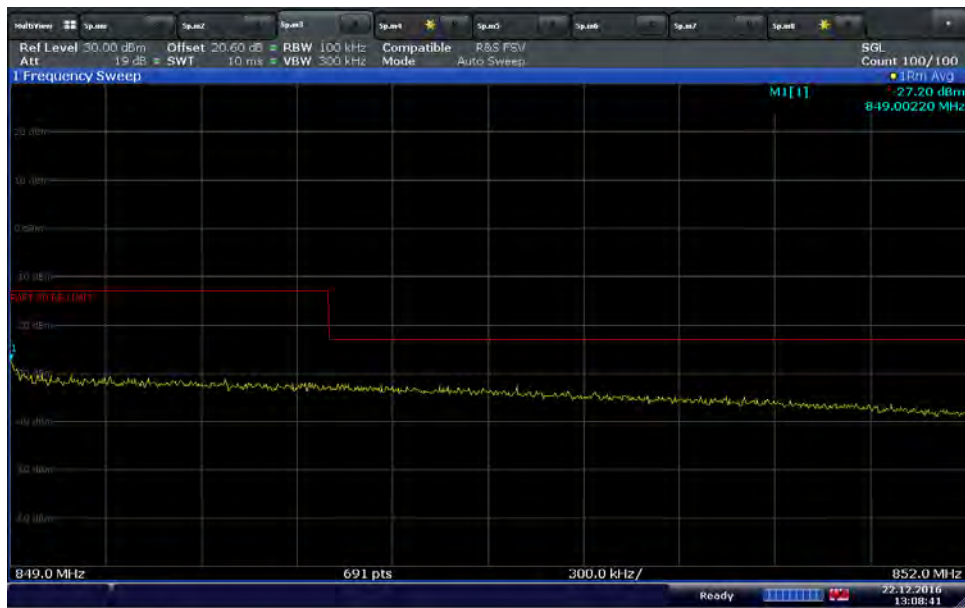

Date: 22 DEC 2016 13:08:41

LTE Band 5 Uplink 5MHz Bandwidth Low Channel (-71 dBm)

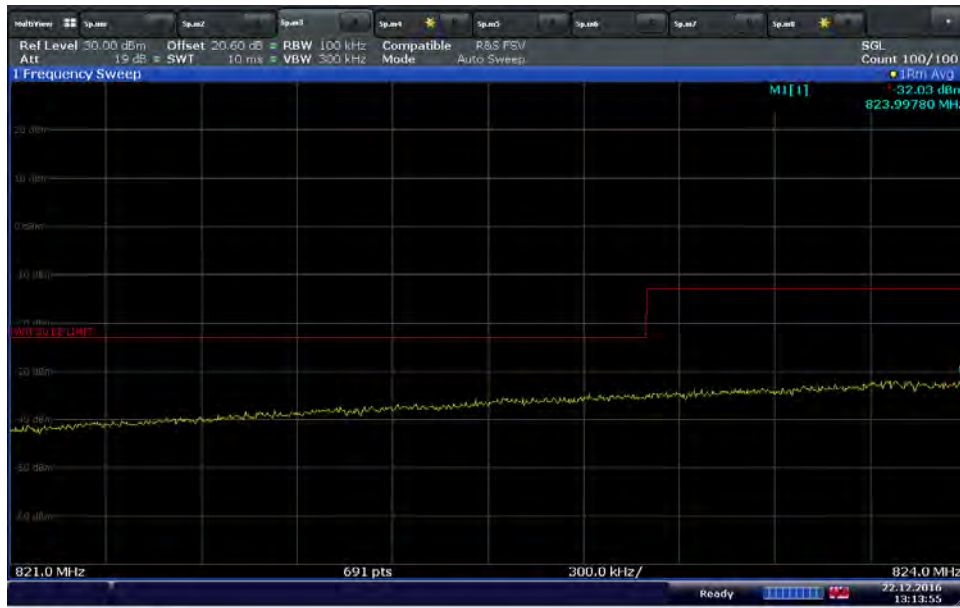

Date: 22 DEC 2016 13:13:56

LTE Band 5 Uplink 5MHz Bandwidth Low Channel (0 dBm)

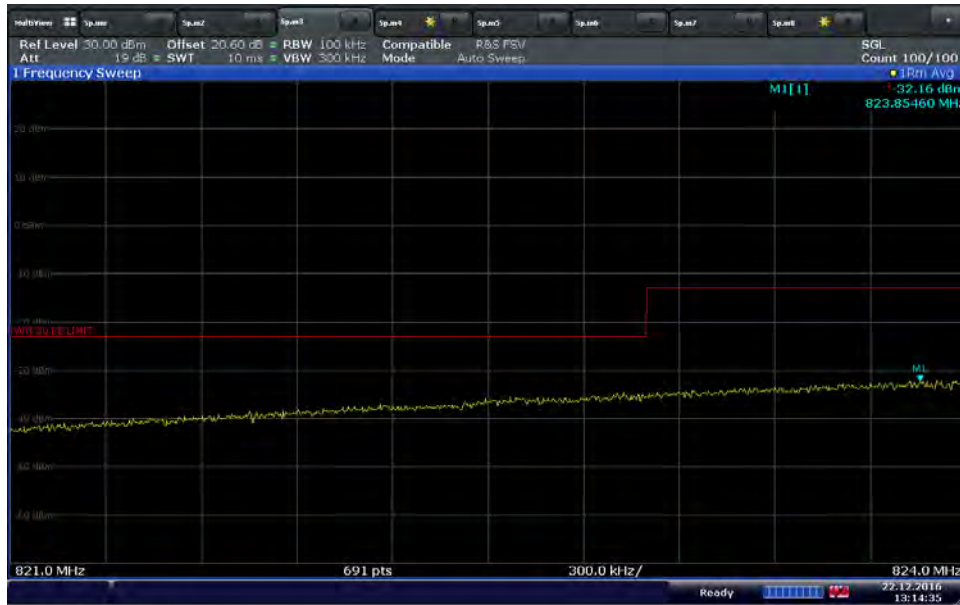

Date: 22 DEC 2016 13:14:35

LTE Band 5 Uplink 5MHz Bandwidth High Channel (-71 dBm)



Date: 22 DEC 2016 13:12:01

LTE Band 5 Uplink 5MHz Bandwidth High Channel (0 dBm)

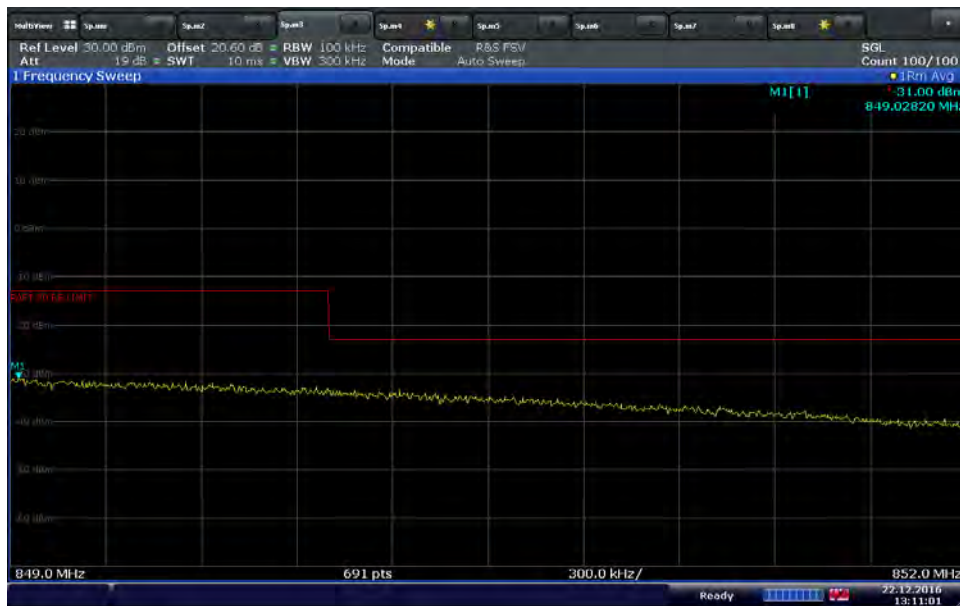

Date: 22 DEC 2016 13:11:01

LTE Band 12 Uplink 5MHz Bandwidth Low Channel (-71 dBm)

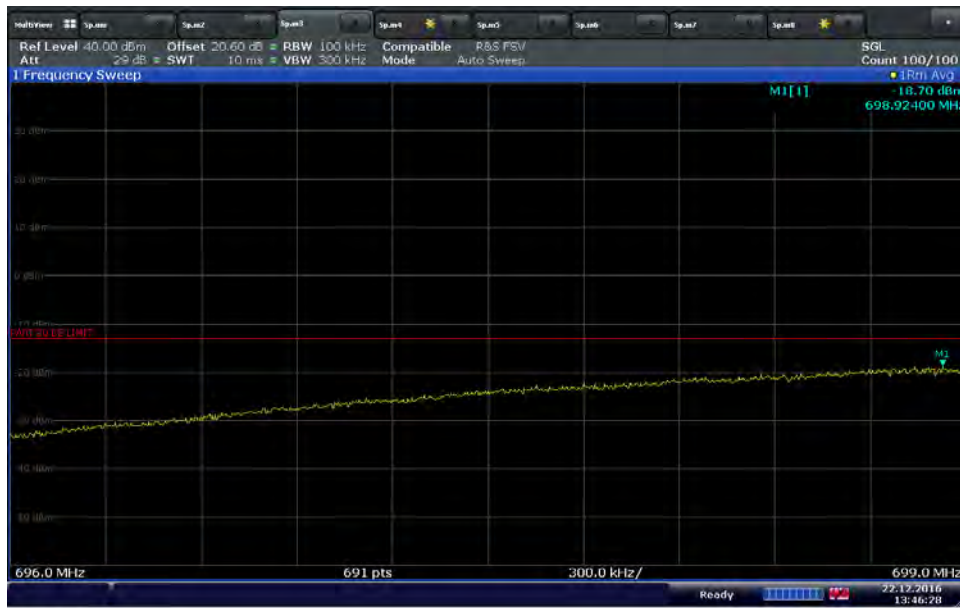

Date: 22 DEC 2016 13:46:28

LTE Band 12 Uplink 5MHz Bandwidth Low Channel (0 dBm)



Date: 22 DEC 2016 13:45:54

LTE Band 12 Uplink 5MHz Bandwidth High Channel (-71 dBm)



Date: 22 DEC 2016 13:51:00

LTE Band 12 Uplink 5MHz Bandwidth High Channel (0 dBm)

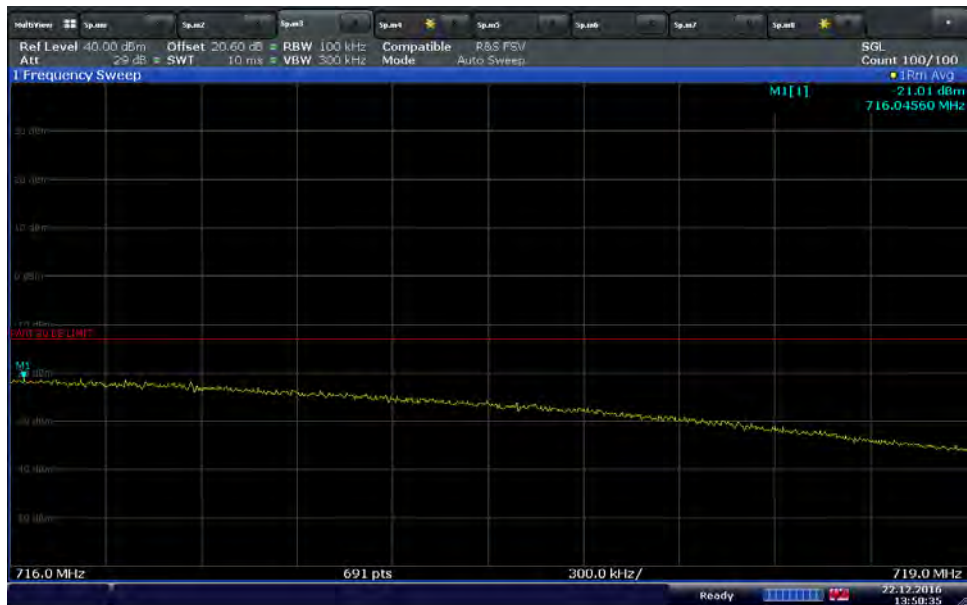

Date: 22 DEC 2016 13:50:35

LTE Band 13 Uplink 5MHz Bandwidth Low Channel (-71 dBm)



Date: 22 DEC 2016 13:55:22

LTE Band 13 Uplink 5MHz Bandwidth Low Channel (0 dBm)



Date: 22 DEC 2016 13:56:15

LTE Band 13 Uplink 5MHz Bandwidth High Channel (-71 dBm)

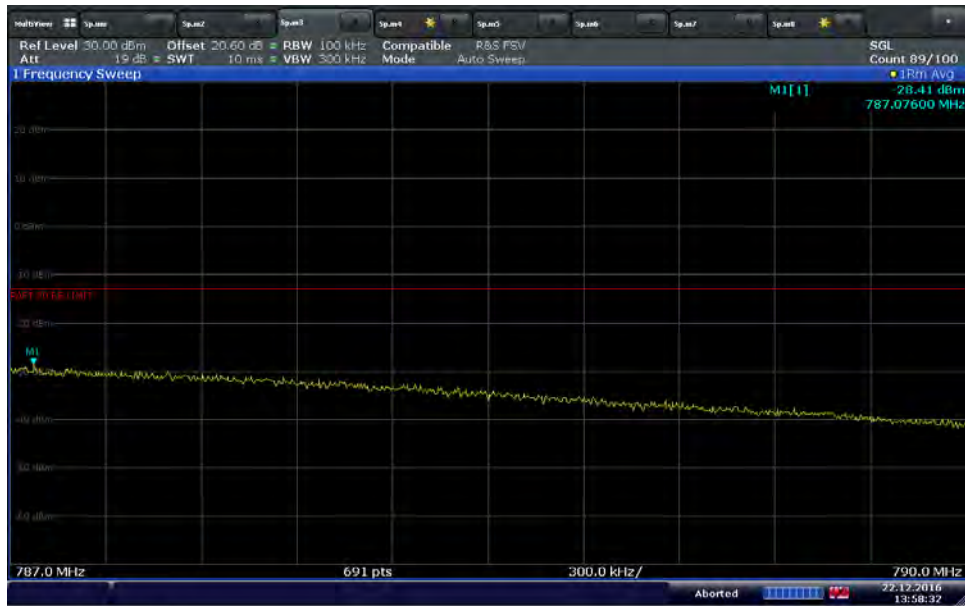

Date: 22 DEC 2016 13:58:32

LTE Band 13 Uplink 5MHz Bandwidth High Channel (0 dBm)

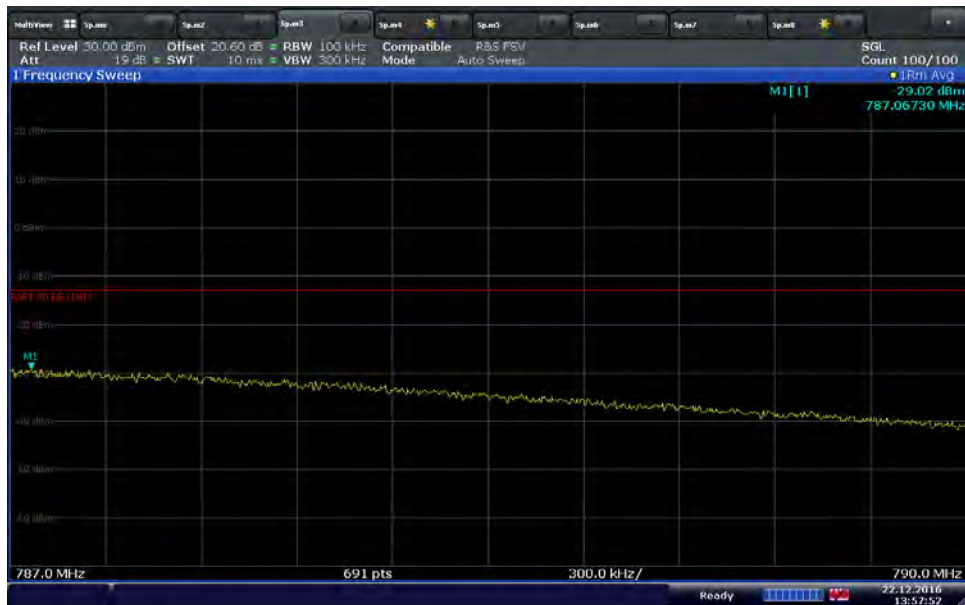

Date: 22 DEC 2016 13:57:52

LTE Band 4 Uplink 5MHz Bandwidth Low Channel (-71 dBm)

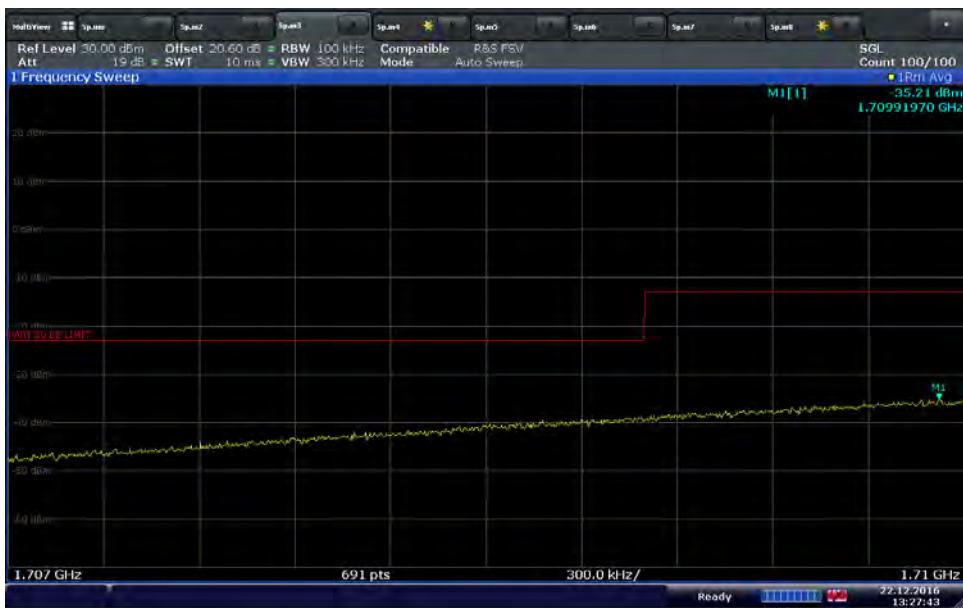

Date: 22 DEC 2016 13:27:43

LTE Band 4 Uplink 5MHz Bandwidth Low Channel (0 dBm)

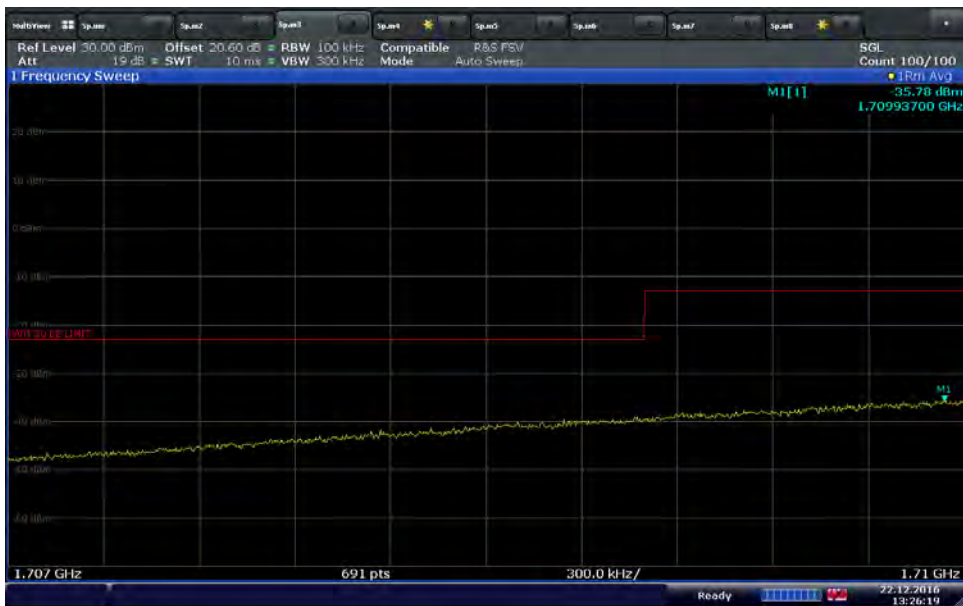

Date: 22 DEC 2016 13:26:19

LTE Band 4 Uplink 5MHz Bandwidth High Channel (-71 dBm)

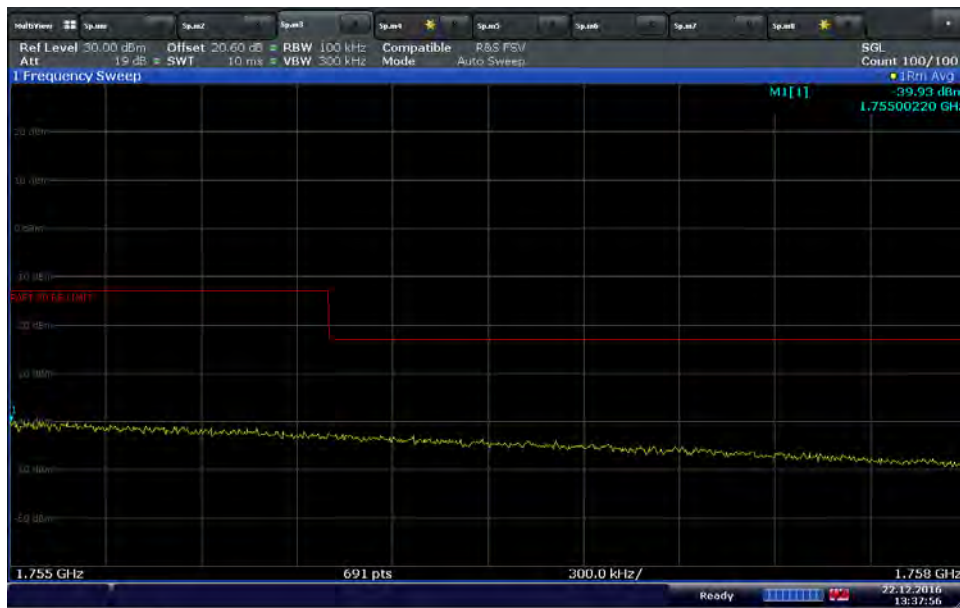

Date: 22 DEC 2016 13:37:57

LTE Band 4 Uplink 5MHz Bandwidth High Channel (0 dBm)



Date: 22 DEC 2016 13:39:04

2.7 NOISE LIMIT

2.7.1 Specification Reference

FCC 47 CFR Part 20. Clause 20.21(e)(9)(i)(A)
FCC 47 CFR Part 20. Clause 20.21(e)(9)(i)(I)
KDB935210 D04, Clause 7.7

2.7.2 Standard Applicable

FCC 47 CFR Part 20. Clause 20.21(e)(9)(i)(A) Noise Limits.:

The transmitted noise power in dBm/MHz of frequency selective consumer boosters outside the licensee's spectrum blocks at their uplink and downlink ports shall not exceed the following limits:

(1) -103 dBm/MHz - RSSI

(i) Where RSSI is the downlink composite signal power received in dBm for frequencies in the band of operation outside the licensee's spectrum block as measured after spectrum block filtering is applied and is referenced to the booster's donor port for each band of operation. RSSI is expressed in negative dB units relative to 1 mW.

(ii) Boosters with MSCL less than 40 dB, shall reduce the Noise output in (A) by 40 dB - MSCL, where MSCL is the minimum coupling loss in dB between the wireless device and booster's server port. MSCL must be calculated or measured for each band of operation and provided in compliance test reports.

(2)(i) Fixed booster Maximum downlink noise power shall not exceed $-102.5 \text{ dBm/MHz} + 20 \text{ Log}_{10}(\text{Frequency})$, where Frequency is the uplink mid-band frequency of the supported spectrum bands in MHz.

(ii) Mobile booster maximum noise power shall not exceed -59 dBm/MHz.

(iii) Compliance with Noise limits will use instrumentation calibrated in terms of RMS equivalent voltage, and with booster input ports terminated or without input signals applied within the band of measurement.

FCC 47 CFR Part 20. Clause 20.21(e)(9)(i)(I) Transmit Power Off Mode.

When the consumer booster cannot otherwise meet the noise and gain limits defined herein it must operate in "Transmit Power OFF Mode." In this mode of operation, the uplink and downlink noise power shall not exceed -70 dBm/MHz and uplink gain shall not exceed the lesser of 23 dB or MSCL.

2.7.3 Equipment Under Test and Modification State

Serial No: 332633000356, 932703000264 and 932703000165 / Test Configuration G, H and I

2.7.4 Date of Test/Initial of test personnel who performed the test

January 23, February 20 and 22, 2017/XYZ

2.7.5 Test Equipment Used

The major items of test equipment used for the above tests are identified in Section 3.1.

2.7.6 Environmental Conditions/ Test Location

Test performed at TÜV SÜD America Inc. Rancho Bernardo facility

Ambient Temperature	20.5 – 25.4°C
Relative Humidity	40.8 - 59.7%
ATM Pressure	99.1 - 99.9kPa

2.7.7 Additional Observations

- 1) This is conducted Test. Test procedure is per Section 7.7 of KDB935210 (D04 Provider Specific Booster Measurements v02). Appropriate offset (line losses) applied.
- 2) The EUT operated in Test Mode with the gain manually set to the maximum gain and a minimum bandwidth setting (5MHz).
- 3) For Maximum Noise (frequency Dependent) testing, setup the EUT according to Figure 6 of Section 7.7 of KDB935210 (D04 Provider Specific Booster Measurements v02).
- 4) Maximum Noise (frequency Dependent) evaluations are conducted at Server ports. Operational downlink bands for WCDMA Band 2, 5, and LTE Band 2, 5, 12, 13 and 4 were tested.
- 5) For Maximum Noise (RSSI Dependent and Transmit Power off mode) and Noise Response Time tests, setup the EUT according to Figure 7 or 8 of Section 7.7 of KDB935210 (D04 Provider Specific Booster Measurements v02) as appropriate.
- 6) Maximum Noise (RSSI Dependent and Transmit Power off mode) and Noise Response Time evaluations are conducted at Server and Donor ports.
- 7) Operational uplink and downlink bands for WCDMA Band 2, 5, and LTE Band 2, 5, 12, 13 and 4 were tested.
- 8) Both Fix Unit and Mobile Units were tested.
- 9) Signal generator was configured to transmit: 4.1 MHz AWGN.

2.7.8 Test Results

Maximum Noise (Frequency Dependent) – Fix Unit				
Band	Frequency Range (MHz)	Max Noise (dBm/MHz)	Limit* (dBm/MHz)	Margin (dB)
WCDMA Band 2 Downlink	1930 - 1990	-70.93	-37.02	33.91
LTE Band 2 Downlink	1930 - 1990	-71.07	-37.02	34.05
WCDMA Band 5 Downlink	869 - 894	-68.65	-44.05	24.6
LTE Band 5 Downlink	869 - 894	-68.46	-44.05	24.41
LTE Band 12 Downlink	729 - 746	-68.11	-45.51	22.6
LTE Band 13 Downlink	746 - 756	-68.16	-44.64	23.52
LTE Band 4 Downlink	2110 - 2155	-72.11	-37.72	34.39

*: $-102.5 \text{ dBm/MHz} + 20 \text{ Log}_{10}(\text{Frequency})$, where Frequency is the uplink mid-band frequency of the supported spectrum bands in MHz. (Downlink only)

Maximum Noise (Frequency Dependent) – Mobile Unit				
Band	Frequency Range (MHz)	Max Noise (dBm/MHz)	Limit (dBm/MHz)	Margin (dB)
WCDMA Band 2 Downlink	1930 - 1990	-73.29	-59.0	14.29
LTE Band 2 Downlink	1930 - 1990	-73.50	-59.0	14.5
WCDMA Band 5 Downlink	869 - 894	-70.75	-59.0	11.75
LTE Band 5 Downlink	869 - 894	-70.63	-59.0	11.63
LTE Band 12 Downlink	729 - 746	-71.08	-59.0	12.08
LTE Band 13 Downlink	746 - 756	-70.98	-59.0	11.98
LTE Band 4 Downlink	2110 - 2155	-72.56	-59.0	13.56

Maximum Noise (RSSI Dependent and Transmit Power off mode) – Fix Unit					
Band	Frequency (MHz)	Signal Generator Output Level (dBm)	Max Noise (dBm/MHz)	Limit (dBm/MHz)	Margin (dB)
WCDMA Band 2 Downlink	1930 - 1990	-72.2	-72.89	-35.8	37.09
		-62.2	-72.32	-45.8	26.52
		-52.2	-72.45	-55.8	16.65
		-42.2**	-84.22	-65.8	18.42
		-32.2	-84.67	-70	14.67
		-22.2	-84.5	-70	14.5
WCDMA Band 2 Uplink	1850 - 1910	-87.2	-74.99	-20.8	54.19
		-77.2	-75.34	-30.8	44.54
		-67.2	-77.89	-40.8	37.09
		-47.2**	-81.83	-60.8	21.03
		-37.2	-81.43	-70	11.43
		-27.2	-81.65	-70	11.65
LTE Band 2 Downlink	1930 - 1990	-82.2	-74.5	-25.8	48.7
		-72.2	-74.47	-35.8	38.67
		-62.2	-74.32	-45.8	28.52
		-39.2**	-85.46	-68.8	16.66
		-32.2	-85.43	-70	15.43
		-21.2	-85.65	-70	15.65
LTE Band 2 Uplink	1850 - 1910	-87.2	-75.36	-20.8	54.56
		-77.2	-75.67	-30.8	44.87
		-57.2	-78.1	-50.8	27.3
		-47.2**	-81.83	-60.8	21.03
		-37.2	-82.03	-70	12.03
		-27.2	-81.96	-70	11.96

WCDMA Band 5 Downlink	869 - 894	-71.3	-70.37	-36.7	33.67
		-61.3	-70.25	-46.7	23.55
		-51.3	-71.84	-56.3	15.14
		-41.3**	-80.8	-66.7	14.1
		-31.3	-81.02	-70	11.02
		-21.3	-80.83	-70	10.83
WCDMA Band 5 Uplink	824 - 849	-86.3	-69.78	-21.7	48.08
		-76.3	-69.55	-31.7	37.85
		-56.3	-76.12	-51.7	24.42
		-46.3**	-80.06	-61.7	18.36
		-36.3	-80.32	-70	10.32
		-26.3	-80.12	-70	10.12
LTE Band 5 Downlink	869 - 894	-71.3	-73.76	-36.7	37.06
		-61.3	-72.97	-46.7	26.27
		-51.3	-78.21	-56.7	21.51
		-41.3**	-81.6	-66.7	14.9
		-31.3	-81.34	-70	11.34
		-21.3	-81.66	-70	11.66
LTE Band 5 Uplink	824 - 849	-76.3	-69.13	-31.7	37.43
		-66.3	-75.02	-41.7	33.32
		-56.3	-79.85	-51.7	28.15
		-46.3**	-80.19	-61.7	18.49
		-36.3	-80.87	-70	10.87
		-26.3	-80.77	-70	10.77
LTE Band 12 Downlink	729 - 746	-82.4	-71.07	-25.6	45.47
		-72.4	-71.82	-35.6	36.22
		-57.4	-78.34	-50.6	27.74
		-52.4**	-82.88	-55.6	27.28
		-42.4	-82.76	-65.6	17.16
		-32.4	-83.1	-70	13.1
LTE Band 12 Uplink	699 - 716	-86.3	-71.58	-21.7	49.88
		-76.3	-71.19	-31.7	39.49
		-66.3	-78.1	-41.7	36.4
		-56.3**	-81.26	-51.7	29.56
		-46.3	-81.96	-61.7	20.26
		-36.3	-81.54	-70	11.54
LTE Band 13 Downlink	746 - 756	-81.4	-71.87	-26.6	45.27
		-71.4	-71.93	-36.6	35.33
		-61.4	-77.14	-46.6	30.54
		-51.4**	-83.06	-56.6	26.46
		-46.4	-83.34	-61.6	21.74
		-31.4	-83.48	-70	13.48
LTE Band 13 Uplink	777 - 787	-86.3	-70.08	-21.7	48.38
		-76.3	-71.34	-31.7	39.64
		-61.3	-77.49	-46.7	30.79
		-56.3**	-80.22	-51.7	28.52
		-46.3	-81.09	-61.7	19.39
		-36.3	-81.11	-70	11.11

LTE Band 4 Downlink	2110 – 2155	-72.2	-77.73	-35.8	41.93
		-62.2	-80.32	-45.8	34.52
		-52.2**	-85.51	-55.8	29.71
		-42.2	-86.26	-65.8	20.46
		-32.2	-86.13	-70	24.43
		-22.2	-86.2	-70	16.13
LTE Band 4 Uplink	1710 - 1755	-77.2	-73.06	-30.8	42.26
		-67.2	-74.92	-40.8	34.12
		-57.2**	-79.37	-50.8	28.57
		-47.2	-79.86	-60.8	19.06
		-37.2	-79.81	-70	9.81
		-27.2	-78.58	-70	8.58

** : Transmit Power off mode

Maximum Noise (RSSI Dependent and Transmit Power off mode) – Mobile Unit					
Band	Frequency (MHz)	Signal Generator Output Level (dBm)	Max Noise (dBm/MHz)	Limit (dBm/MHz)	Margin (dB)
WCDMA Band 2 Downlink	1930 - 1990	-72.2	-76.74	-35.8	40.94
		-62.2	-76.67	-45.8	30.87
		-52.2	-76.77	-55.8	20.97
		-42.2	-76.8	-65.8	11
		-32.2	-77.21	-70	7.21
		-22.2	-77.3	-70	7.3
WCDMA Band 2 Uplink	1850 - 1910	-87.2	-83.89	-20.8	63.09
		-77.2	-83.75	-30.8	52.95
		-67.2	-84.05	-40.8	43.25
		-47.2	-83.68	-60.8	22.88
		-37.2	-83.77	-70	13.77
		-27.2**	-83.76	-70	13.76
LTE Band 2 Downlink	1930 - 1990	-82.2	-84.95	-25.8	59.15
		-72.2	-84.67	-35.8	48.87
		-62.2	-84.81	-45.8	39.01
		-39.2	-84.43	-68.8	15.63
		-32.2	-84.64	-70	14.64
		-21.2	-76.65	-70	6.65
LTE Band 2 Uplink	1850 - 1910	-87.2	-84.15	-20.8	63.35
		-77.2	-84.08	-30.8	53.28
		-57.2	-84.01	-50.8	33.21
		-47.2	-83.98	-60.8	23.18
		-37.2	-84.22	-70	14.22
		-27.2**	-83.96	-70	13.96

WCDMA Band 5 Downlink	869 - 894	-71.3	-83.88	-36.7	47.18
		-61.3	-83.37	-46.7	36.67
		-51.3	-83.43	-56.3	27.13
		-41.3	-83.65	-66.7	16.95
		-31.3	-73.17	-70	3.17
		-21.3	-73.23	-70	3.23
WCDMA Band 5 Uplink	824 - 849	-86.3	-81.44	-21.7	59.74
		-76.3	-80.87	-31.7	49.17
		-56.3	-81.12	-51.7	29.42
		-46.3	-81.07	-61.7	19.37
		-36.3	-81.23	-70	11.23
		-26.3**	-81.18	-70	11.18
LTE Band 5 Downlink	869 - 894	-71.3	-84.61	-36.7	47.91
		-61.3	-84.49	-46.7	37.79
		-51.3	-84.1	-56.7	27.4
		-41.3	-83.87	-66.7	17.17
		-31.3	-72.54	-70	2.54
		-21.3	-72.24	-70	2.24
LTE Band 5 Uplink	824 - 849	-76.3	-78.51	-31.7	46.81
		-66.3	-78.08	-41.7	36.38
		-56.3	-78.15	-51.7	26.45
		-46.3	-78.13	-61.7	16.43
		-36.3	-78.82	-70	8.82
		-26.3**	-78.72	-70	8.72
LTE Band 12 Downlink	729 - 746	-82.4	-82.39	-25.6	56.79
		-72.4	-82.13	-35.6	46.53
		-57.4	-82.55	-50.6	31.95
		-52.4	-82.34	-55.6	26.74
		-42.4	-82.3	-65.6	16.7
		-32.4	-80.89	-70	10.89
LTE Band 12 Uplink	699 - 716	-86.3	-80.01	-21.7	58.31
		-76.3	-80.12	-31.7	48.42
		-66.3	-80.1	-41.7	38.4
		-56.3	-80.22	-51.7	28.52
		-46.3	-80.0	-61.7	18.3
		-26.3**	-80.31	-70	10.31
LTE Band 13 Downlink	746 - 756	-81.4	-84.06	-26.6	57.46
		-71.4	-84.21	-36.6	47.61
		-61.4	-84.12	-46.6	37.52
		-51.4	-84.09	-56.6	27.49
		-46.4	-83.96	-61.6	22.36
		-31.4	-83.91	-70	13.91
LTE Band 13 Uplink	777 - 787	-86.3	-79.09	-21.7	57.39
		-76.3	-79.31	-31.7	47.61
		-61.3	-79.4	-46.7	32.7
		-56.3	-79.42	-51.7	27.72
		-46.3	-79.03	-61.7	17.33
		-26.3**	-79.17	-70	9.17

LTE Band 4 Downlink	2110 – 2155	-72.2	-86.08	-35.8	50.28
		-62.2	-86.11	-45.8	40.31
		-52.2	-85.98	-55.8	30.18
		-42.2	-86.27	-65.8	20.47
		-32.2	-86.18	-70	16.18
		-22.2	-86.24	-70	16.24
LTE Band 4 Uplink	1710 - 1755	-77.2	-77.18	-30.8	46.38
		-67.2	-76.97	-40.8	36.17
		-57.2	-76.92	-50.8	26.12
		-47.2	-76.8	-60.8	16
		-37.2	-76.92	-70	6.92
		-27.2	-77.62	-70	7.62

** : Transmit Power off mode

Noise Response Time – Fix Unit				
Band	Frequency (MHz)	Noise Response Time (Sec)	Limit (Sec)	Margin (Sec)
WCDMA Band 2 Downlink	1930 - 1990	0.565	3	2.435
WCDMA Band 2 Uplink	1850 - 1910	0.377	3	2.623
LTE Band 2 Downlink	1930 - 1990	0.551	3	2.449
LTE Band 2 Uplink	1850 - 1910	0.319	3	2.681
WCDMA Band 5 Downlink	869 - 894	0.579	3	2.421
WCDMA Band 5 Uplink	824 - 849	0.391	3	2.609
LTE Band 5 Downlink	869 - 894	0.564	3	2.436
LTE Band 5 Uplink	824 - 849	0.565	3	2.435
LTE Band 12 Downlink	729 - 746	0.536	3	2.464
LTE Band 12 Uplink	699 - 716	0.754	3	2.246
LTE Band 13 Downlink	746 - 756	0.623	3	2.377
LTE Band 13 Uplink	777 - 787	0.565	3	2.435
LTE Band 4 Downlink	2110 - 2155	0.536	3	2.464
LTE Band 4 Uplink	1710 - 1755	0.55	3	2.45

N/A*: Not Applicable for the EUT doesn't work in power-off mode.

Noise Response Time – Mobile Unit				
Band	Frequency (MHz)	Noise Response Time (Sec)	Limit (Sec)	Margin (Sec)
WCDMA Band 2 Downlink	1930 - 1990	N/A*	3	-
WCDMA Band 2 Uplink	1850 - 1910	0.232	3	2.768
LTE Band 2 Downlink	1930 - 1990	N/A*	3	-
LTE Band 2 Uplink	1850 - 1910	0.232	3	2.768
WCDMA Band 5 Downlink	869 - 894	N/A*	3	-
WCDMA Band 5 Uplink	824 - 849	0.246	3	2.754
LTE Band 5 Downlink	869 - 894	N/A*	3	-
LTE Band 5 Uplink	824 - 849	0.203	3	2.797
LTE Band 12 Downlink	729 - 746	N/A*	3	-
LTE Band 12 Uplink	699 - 716	0.232	3	2.768
LTE Band 13 Downlink	746 - 756	N/A*	3	-
LTE Band 13 Uplink	777 - 787	0.188	3	2.812
LTE Band 4 Downlink	2110 - 2155	N/A*	3	-
LTE Band 4 Uplink	1710 - 1755	0.261	3	2.739

N/A*: Not Applicable for the EUT doesn't work in power-off mode.

2.8 UPLINK INACTIVITY

2.8.1 Specification Reference

FCC 47 CFR Part 20. Clause 20.21(e)(9)(i)(J)
KDB935210 D04, Clause 7.8

2.8.2 Standard Applicable

FCC 47 CFR Part 20. Clause 20.21(e)(9)(i)(J) Uplink Inactivity:
Uplink Inactivity. When a consumer booster is not serving an active device connection after 5 seconds the uplink noise power shall not exceed -70 dBm/MHz.

2.8.3 Equipment Under Test and Modification State

Serial No: 332633000271 / Test Configuration C and D

2.8.4 Date of Test/Initial of test personnel who performed the test

December 28, 2016/XYZ

2.8.5 Test Equipment Used

The major items of test equipment used for the above tests are identified in Section 3.1.

2.8.6 Environmental Conditions

Test performed at TÜV SÜD America Inc. Rancho Bernardo facility.

Ambient Temperature	22.4°C
Relative Humidity	30.4%
ATM Pressure	99.4kPa

2.8.7 Additional Observations

- 1) This is conducted Test.
- 2) Test procedure is per Section 7.8 of KDB935210 (D04 Provider Specific Booster Measurements v02).
Appropriate offset (line losses) applied.
- 3) The Fix Unit operated in Normal Mode with a minimum bandwidth setting (5MHz).
- 4) Setup the EUT according to Figure 1 of Section 6.3.2 of KDB935210 (D04 Provider Specific Booster Measurements v02).
- 5) Evaluations are conducted at Donor (NU) antenna ports.
- 6) Operational uplink bands for WCDMA Band 2, 5, and LTE Band 2, 5, 12, 13 and 4 were tested.
- 7) Signal: 5MHz LTE or WCDMA.

2.8.8 Test Results

Uplink Inactivity				
Band	Frequency (MHz)	UL Inactive Time (Sec)	Limit (Sec)	Margin (Sec)
WCDMA Band 2 Uplink	1880	1.61	5.0	3.39
LTE Band 2 Uplink	1880	1.57	5.0	3.43
WCDMA Band 5 Uplink	836.6	1.43	5.0	3.57
LTE Band 5 Uplink	836.5	1.48	5.0	3.52
LTE Band 12 Uplink	707	1.39	5.0	3.61
LTE Band 13 Uplink	782	1.57	5.0	3.43
LTE Band 4 Uplink	1732.5	1.52	5.0	3.48

WCDMA Band 2 Uplink 5MHz Bandwidth Mid Channel

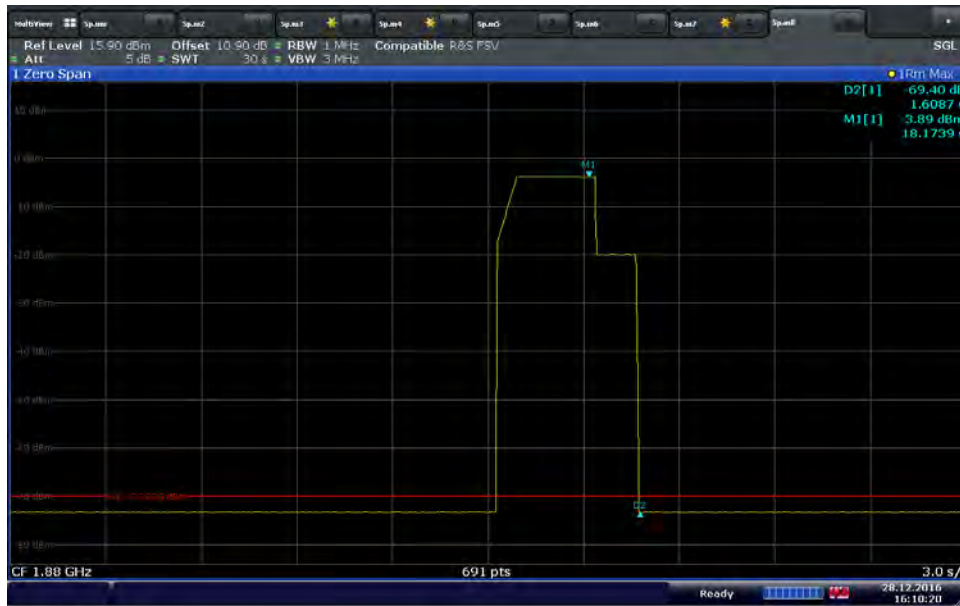

Date: 28 DEC 2016 16:10:21

LTE Band 2 Uplink 5MHz Bandwidth Mid Channel



Date: 28 DEC 2016 16:30:10

WCDMA Band 5 Uplink 5MHz Bandwidth Mid Channel



Date: 28 DEC 2016 16:18:31

LTE Band 5 Uplink 5MHz Bandwidth Mid Channel

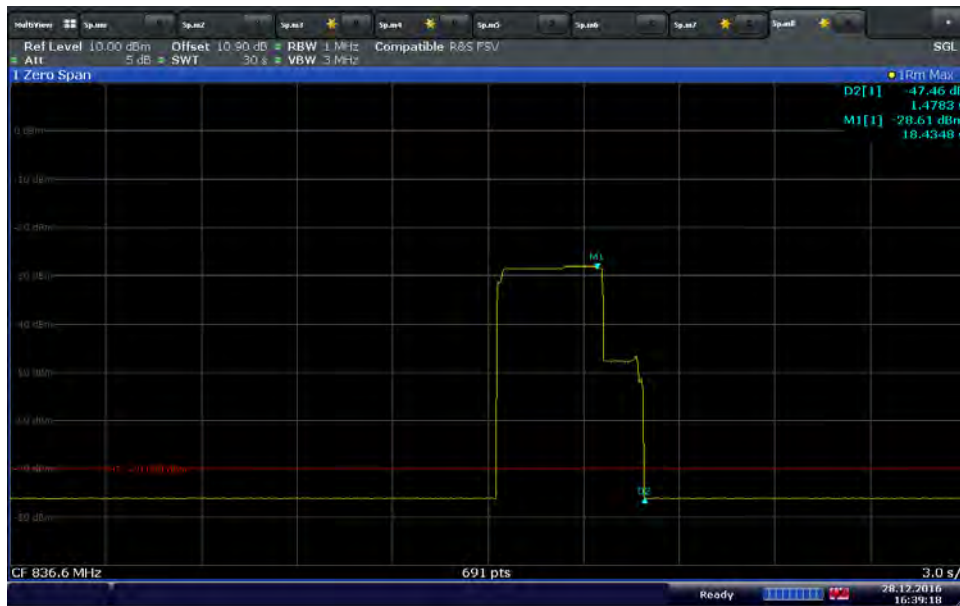

Date: 28 DEC 2016 16:39:18

LTE Band 12 Uplink 5MHz Bandwidth Mid Channel

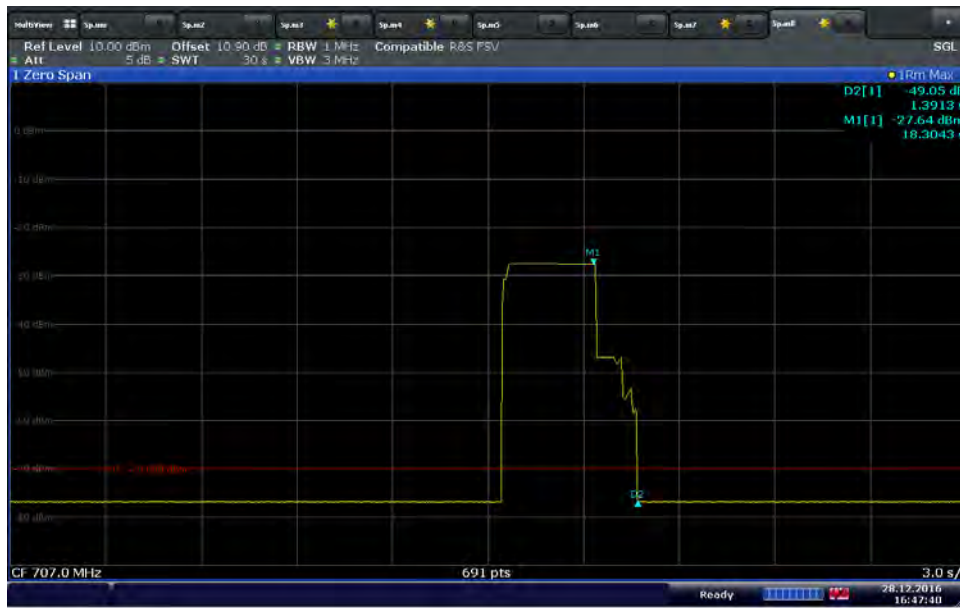

Date: 28 DEC 2016 16:47:41

LTE Band 13 Uplink 5MHz Bandwidth Mid Channel



Date: 28 DEC 2016 16:57:12

LTE Band 4 Uplink 5MHz Bandwidth Mid Channel



2.9 VARIABLE BOOSTER GAIN

2.9.1 Specification Reference

FCC 47 CFR Part 20. Clause 20.21(e)(9)(i)(C)(1)
FCC 47 CFR Part 20. Clause 20.21(e)(9)(i)(I)
KDB935210 D04, Clause 7.9

2.9.2 Standard Applicable

FCC 47 CFR Part 20. Clause 20.21(e)(9)(i)(C)(1) Booster Gain Limits:
The gain of the frequency selective consumer booster shall meet the limits below.

- 1) The uplink and downlink gain in dB of a frequency selective consumer booster referenced to its input and output ports shall not exceed BSCL - 28dB - (40 dB - MSCL).
 - (i) Where BSCL is the coupling loss between the booster's donor port and the base station's input port, and MSCL is the minimum coupling loss in dB between the wireless device and the booster's server port. MSCL must be calculated or measured for each band of operation and provided in compliance test reports.
 - (ii) In order of preference, BSCL is determined as follows: determine path loss between the base station and the booster; such measurement shall be based on measuring the received forward pilot/control channel power at the booster and reading the pilot/control channel transmit power from the base station as defined in the system information messages sent by the base station; estimate BSCL by assuming that the base station is transmitting at a level of +25 dBm per channel (assume a small, lightly loaded cell) and measuring the total received signal power level within the channel in dBm (RPCH) received at the booster input port. BSCL is then calculated as 25- RPCH; or assume that the BSCL is 70dB without performing any measurement.

FCC 47 CFR Part 20. Clause 20.21(e)(9)(i)(I) Transmit Power Off Mode.
When the consumer booster cannot otherwise meet the noise and gain limits defined herein it must operate in "Transmit Power OFF Mode." In this mode of operation, the uplink and downlink noise power shall not exceed -70 dBm/MHz and uplink gain shall not exceed the lesser of 23 dB or MSCL.

2.9.3 Equipment Under Test and Modification State

Serial No: 932703000073, 932703000059 / Test Configuration C and D

2.9.4 Date of Test/Initial of test personnel who performed the test

January 25 and February 22, 2017/XYZ

2.9.5 Test Equipment Used

The major items of test equipment used for the above tests are identified in Section 3.1.

2.9.6 Environmental Conditions

Test performed at TÜV SÜD America Inc. Rancho Bernardo facility.

Ambient Temperature	21.0 - 25.4°C
Relative Humidity	42.7 - 48.5%
ATM Pressure	99.2 - 99.5kPa

2.9.7 Additional Observations

- 1) This is conducted Test.
- 2) Test procedure is per Section 7.9 of KDB935210 (D04 Provider Specific Booster Measurements v02). Appropriate offset (line losses) applied.
- 3) The EUT operated in Normal Mode;
- 4) Setup the EUT according to Figure 1 of Section 6.3.2 of KDB935210 (D04 Provider Specific Booster Measurements v02).
- 5) Evaluations are conducted at Server and Donor antenna ports.
- 6) Variable Gain: Operational uplink and downlink bands for WCDMA Band 2, 5, and LTE Band 2, 5, 12, 13 and 4 were tested.
- 7) Uplink Gain Timing: Operational uplink bands for WCDMA Band 2, 5, and LTE Band 2, 5, 12, 13 and 4 were tested.
- 8) Both Fix Unit and Mobile Units were tested.
- 9) Signal: 5MHz LTE or WCDMA.
- 10) MSCL:
 - $L_p = 20\log f + 20\log d - 27.5$
 - L_p = Basic free space path loss,
 - f = frequency in MHz,
 - d = separation distance in meters (2m)
 - lowest MSCL value was utilized.
- 11) BSCL:
 - The coupling loss (in dB) between the donor port (NU) of the Consumer Booster and the input port of the Base Station

2.9.8 Test Results

WCDMA Band 2 Downlink Gain vs RPDH and BSCL - Middle Channel (Fix Unit)					
RPCH Power (dBm)	BSCL (dB)	Measured Power (dBm)	Gain (dB)	Limit (dB)	Margin (dB)
-98.5	123.5	6.4	83.83	85	1.17
-88.5	113.5	6.61	74.04	85	10.96
-78.5	103.5	6.53	63.96	76.5	12.55
-68.5	93.5	6.5	53.93	66.5	12.58
-58.5	83.5	6.25	43.68	56.5	12.83
-48.5	73.5	6.43	33.86	46.5	12.65

LTE Band 2 Downlink Gain vs RPCH and BSCL - Middle Channel (Fix Unit)					
RPCH Power (dBm)	BSCL (dB)	Measured Power (dBm)	Gain (dB)	Limit (dB)	Margin (dB)
-103.3	128.3	7.22	80.59	85	4.41
-93.3	118.3	7.33	70.7	85	4.3
-83.3	108.3	7.37	60.74	85	4.26
-73.3	98.3	7.25	50.62	71.3	20.69
-63.3	88.3	7.2	40.57	61.3	20.74
-53.3	78.3	7.47	30.84	51.3	20.47

WCDMA B5 Downlink Gain vs RPCH and BSCL - Middle Channel (Fix Unit)					
RPCH Power (dBm)	BSCL (dB)	Measured Power (dBm)	Gain (dB)	Limit (dB)	Margin (dB)
-91.3	96.3	6.6	84.03	85	0.97
-81.3	86.3	6.96	74.39	85	10.61
-71.3	76.3	6.59	64.02	69.3	5.28
-61.3	86.3	6.55	53.98	59.3	5.32
-51.3	76.3	6.46	43.89	49.3	5.41
-41.3	66.3	6.97	34.4	39.3	4.9

LTE Band 5 Downlink Gain vs RPCH and BSCL - Middle Channel (Fix Unit)					
RPCH Power (dBm)	BSCL (dB)	Measured Power (dBm)	Gain (dB)	Limit (dB)	Margin (dB)
-96.1	121.1	8.86	80.87	85	4.13
-86.1	111.1	8.47	70.48	85	14.52
-76.1	101.1	8.6	60.97	74.1	13.13
-66.1	91.1	8.92	50.93	64.1	13.17
-56.1	81.1	8.96	40.97	54.1	13.13
-46.1	71.1	9.16	31.17	44.1	12.93

LTE Band 12 Downlink Gain vs RPCH and BSCL - Middle Channel (Fix Unit)					
RPCH Power (dBm)	BSCL (dB)	Measured Power (dBm)	Gain (dB)	Limit (dB)	Margin (dB)
-95.8	120.8	9.1	80.87	85	4.13
-85.8	110.8	8.79	70.56	85	14.44
-75.8	100.8	9.08	60.85	73.8	12.95
-65.8	90.8	9.15	50.92	63.8	12.88
-55.8	80.8	9.29	41.06	53.8	12.74
-45.8	70.8	9.57	31.34	43.8	12.46

LTE Band 13 Downlink Gain vs RPCH and BSCL - Middle Channel (Fix Unit)					
RPCH Power (dBm)	BSCL (dB)	Measured Power (dBm)	Gain (dB)	Limit (dB)	Margin (dB)
-85.9	120.9	8.94	80.58	85	4.42
-85.9	110.9	8.92	70.56	85	14.44
-65.9	100.9	8.91	60.55	73.9	13.35
-55.9	90.9	9.03	50.67	63.9	13.23
-45.9	80.9	9.11	40.75	53.9	13.15
-35.9	70.9	9.27	30.91	43.9	12.99

LTE B4 Downlink Gain vs RPCH and BSCL - Middle Channel (Fix Unit)					
RPCH Power (dBm)	BSCL (dB)	Measured Power (dBm)	Gain (dB)	Limit (dB)	Margin (dB)
-98.4	123.4	7.08	80.41	85	4.59
-88.4	113.4	6.96	70.29	85	14.71
-78.4	103.4	6.96	60.29	76.4	16.11
-68.4	93.4	7.06	50.39	66.4	16.01
-58.4	83.4	6.98	40.31	56.4	16.09
-48.4	73.4	7.09	30.42	46.4	15.98

WCDMA Band 2 Uplink Gain vs RPCH and BSCL - Middle Channel (Fix Unit)					
RPCH Power (dBm)	BSCL (dB)	Measured Power (dBm)	Gain (dB)	Limit (dB)	Margin (dB)
-92.8	117.8	18.99	72.66	85	12.34
-82.8	107.8	8.92	62.09	85	22.91
-72.8	97.8	-1.48	51.69	70.8	19.11
-62.8	87.8	10.88	42.29	60.8	18.51
-52.8	77.8	-19.96	33.21	50.8	17.59
-42.8	67.8	-29.68	23.49	40.8	17.31

LTE Band 2 Uplink Gain vs RPCH and BSCL - Middle Channel (Fix Unit)					
RPCH Power (dBm)	BSCL (dB)	Measured Power (dBm)	Gain (dB)	Limit (dB)	Margin (dB)
-102.6	127.6	19.69	72.86	85	12.14
-92.6	117.6	19.48	72.65	85	12.35
-82.6	107.6	19.72	72.89	85	12.11
-72.6	97.6	13.29	66.46	70.64	4.18
-62.6	87.6	4.41	57.58	60.64	3.06
-52.6	-77.6	-6.29	46.88	50.64	3.76

WCDMA Band 5 Uplink Gain vs RPCH and BSCL - Middle Channel (Fix Unit)					
RPCH Power (dBm)	BSCL (dB)	Measured Power (dBm)	Gain (dB)	Limit (dB)	Margin (dB)
-92.0	117.0	17.83	69.83	85	15.17
-82	107.0	8.17	60.07	85	24.93
-72	97.0	-1.6	50.4	70	19.6
-62	87.0	-11.69	40.31	60	19.69
-52	77.0	-20.41	31.59	50	18.41
-42	67.0	-30.04	21.96	40	18.04

LTE Band 5 Uplink Gain vs RPCH and BSCL - Middle Channel (Fix Unit)					
RPCH Power (dBm)	BSCL (dB)	Measured Power (dBm)	Gain (dB)	Limit (dB)	Margin (dB)
-101.8	126.8	18.58	70.58	85	14.42
-91.8	116.8	18.45	70.45	85	14.55
-81.8	106.8	18.69	70.69	85	14.31
-71.8	96.8	14.17	66.17	69.8	3.63
-61.8	86.8	4.58	56.58	59.8	3.22
-51.8	76.8	-5.1	46.9	49.8	2.9

LTE Band 12 Uplink Gain vs RPCH and BSCL - Middle Channel (Fix Unit)					
RPCH Power (dBm)	BSCL (dB)	Measured Power (dBm)	Gain (dB)	Limit (dB)	Margin (dB)
-101.7	126.7	18.78	71.95	85	13.05
-91.7	116.7	18.74	71.91	85	13.09
-81.7	106.7	18.81	71.98	85	13.02
-71.7	96.7	13.6	66.77	69.7	2.93
-61.7	86.7	4.76	57.93	59.7	1.77
-51.7	76.7	-4.02	49.15	49.7	0.55

LTE Band 13 Uplink Gain vs RPCH and BSCL - Middle Channel (Fix Unit)					
RPCH Power (dBm)	BSCL (dB)	Measured Power (dBm)	Gain (dB)	Limit (dB)	Margin (dB)
-101.6	126.6	18.74	71.91	85	13.09
-91.6	116.6	18.82	71.99	85	13.01
-81.6	106.6	18.81	71.98	85	13.02
-71.6	96.6	13.64	66.81	69.6	2.79
-61.6	86.6	2.91	56.08	59.6	3.52
-51.6	76.6	-4.96	48.21	49.6	1.39

LTE Band 4 Uplink Gain vs RPCH and BSCL - Middle Channel (Fix Unit)					
RPCH Power (dBm)	BSCL (dB)	Measured Power (dBm)	Gain (dB)	Limit (dB)	Margin (dB)
-102.6	127.6	19.62	72.79	85	12.21
-92.6	117.6	19.6	72.77	85	12.23
-82.6	107.6	19.72	72.89	85	12.11
-72.6	97.6	14.58	67.75	70.7	2.95
-62.6	87.6	5.76	58.93	60.6	1.67
-52.6	77.6	-4.48	48.69	50.6	1.91

WCDMA Band 2 Downlink Gain vs RPCH and BSCL - Middle Channel (Mobile Unit)					
RPCH Power (dBm)	BSCL (dB)	Measured Power (dBm)	Gain (dB)	Limit (dB)	Margin (dB)
-98.51	123.5	-13.33	64.1	65	0.9
-88.	113.5	-47.86	19.57	65	45.43
-78.5	103.5	-38.09	19.34	55.5	36.16
-68.5	93.5	-29.18	18.25	45.5	27.25
-58.5	83.5	-19.39	18.04	35.5	17.46
-48.5	73.5	-9.2	18.23	25.5	7.27

LTE Band 2 Downlink Gain vs RPCH and BSCL - Middle Channel (Mobile Unit)					
RPCH Power (dBm)	BSCL (dB)	Measured Power (dBm)	Gain (dB)	Limit (dB)	Margin (dB)
-103.3	128.3	-9.65	63.72	65	1.28
-93.3	118.3	-46.5	16.87	65	48.13
-83.3	108.3	-36.83	16.54	60.3	43.76
-73.3	98.3	-27.67	15.7	50.3	34.6
-63.3	88.3	-17.75	15.62	40.3	24.68
-53.3	78.3	-7.8	15.57	30.3	14.73

WCDMA B5 Downlink Gain vs RPCH and BSCL - Middle Channel (Mobile Unit)					
RPCH Power (dBm)	BSCL (dB)	Measured Power (dBm)	Gain (dB)	Limit (dB)	Margin (dB)
-91.3	116.3	-16.43	56.9	58	1.1
-81.3	106.3	-46.81	20.62	58	37.38
-71.3	96.3	-36.93	20.5	48.3	27.8
-61.3	86.3	-27.08	20.35	38.3	17.95
-51.3	76.3	-17.77	19.66	28.3	8.64
-41.3	66.3	-17.65	9.78	18.3	8.52

LTE Band 5 Downlink Gain vs RPCH and BSCL - Middle Channel (Mobile Unit)					
RPCH Power (dBm)	BSCL (dB)	Measured Power (dBm)	Gain (dB)	Limit (dB)	Margin (dB)
-96.1	121.1	-15.14	56.87	58	1.13
-86.1	111.1	-44.52	17.49	58	40.51
-76.1	101.1	-34.66	17.35	53.1	35.75
-66.1	91.1	-25.21	16.8	43.1	26.3
-56.1	81.1	-15.41	16.6	33.1	16.5
-46.1	71.1	-7.97	14.04	23.1	9.06

LTE Band 12 Downlink Gain vs RPCH and BSCL - Middle Channel (Mobile Unit)					
RPCH Power (dBm)	BSCL (dB)	Measured Power (dBm)	Gain (dB)	Limit (dB)	Margin (dB)
-95.9	120.9	-13.1	56.67	58	1.33
-85.9	110.9	-43.24	18.53	58	39.47
-75.9	100.9	-33.54	18.23	52.9	34.67
-65.9	90.9	-23.57	18.2	42.9	24.7
-55.9	80.9	-14.87	16.9	32.9	16
-45.9	70.9	-8.94	12.83	22.9	10.07

LTE Band 13 Downlink Gain vs RPCH and BSCL - Middle Channel (Mobile Unit)					
RPCH Power (dBm)	BSCL (dB)	Measured Power (dBm)	Gain (dB)	Limit (dB)	Margin (dB)
-95.9	120.9	-13.17	57.07	58	0.93
-85.9	110.9	-43.06	18.58	58	39.42
-65.9	100.9	-33.5	18.14	52.9	34.76
-55.9	90.9	-23.81	17.83	42.9	25.07
-45.9	80.9	-14.95	16.69	32.9	16.21
-35.9	70.9	-8.96	12.68	22.9	10.22

LTE B4 Downlink Gain vs RPCH and BSCL - Middle Channel (Mobile Unit)					
RPCH Power (dBm)	BSCL (dB)	Measured Power (dBm)	Gain (dB)	Limit (dB)	Margin (dB)
-98.4	123.4	-28.93	44.4	65	20.6
-88.4	113.4	-45.28	18.05	65	46.95
-78.4	103.4	-35.35	17.98	55.4	37.42
-68.4	93.4	-27.73	15.6	45.4	29.8
-58.4	83.4	-17.95	15.38	35.4	20.02
-48.4	73.4	-8.33	15.0	25.4	10.4

WCDMA Band 2 Uplink Gain vs RPCH and BSCL - Middle Channel (Mobile Unit)					
RPCH Power (dBm)	BSCL (dB)	Measured Power (dBm)	Gain (dB)	Limit (dB)	Margin (dB)
-92.8	117.8	9.89	63.06	65	1.94
-82.8	107.8	-38.5	14.67	65	50.33
-72.8	97.8	-38.61	14.56	59.8	45.24
-62.8	87.8	-38.42	14.75	49.8	35.05
-52.8	77.8	-38.42	14.91	39.8	24.89
-42.8	67.8	-38.82	14.35	29.8	15.45

LTE Band 2 Uplink Gain vs RPCH and BSCL - Middle Channel (Mobile Unit)					
RPCH Power (dBm)	BSCL (dB)	Measured Power (dBm)	Gain (dB)	Limit (dB)	Margin (dB)

-102.6	127.6	9.46	62.63	65	2.37
-92.6	117.6	-38.22	14.95	65	50.05
-82.6	107.6	-38.37	14.8	59.6	44.8
-72.6	97.6	-38.72	14.45	49.6	35.15
-62.6	87.6	-38.45	14.72	39.6	24.88
-52.6	77.6	-38.24	14.93	29.6	14.67

WCDMA Band 5 Uplink Gain vs RPCH and BSCL - Middle Channel (Mobile Unit)					
RPCH Power (dBm)	BSCL (dB)	Measured Power (dBm)	Gain (dB)	Limit (dB)	Margin (dB)
-92.0	117.0	5.4	57.4	58	0.6
-82	107.0	-36.18	15.82	58	42.18
-72	97.0	-36.04	15.96	49	33.04
-62	87.0	-36.79	15.21	39	23.79
-52	77.0	-36.36	15.64	29	13.36
-42	67.0	-36.32	15.68	19	3.32

LTE Band 5 Uplink Gain vs RPCH and BSCL - Middle Channel (Mobile Unit)					
RPCH Power (dBm)	BSCL (dB)	Measured Power (dBm)	Gain (dB)	Limit (dB)	Margin (dB)
-101.8	126.8	5.37	57.37	58	0.63
-91.8	116.8	-35.72	16.28	58	41.72
-81.8	106.8	-35.13	16.87	58	41.13
-71.8	96.8	-35.41	16.59	48.8	32.21
-61.8	86.8	-35.53	16.47	38.8	22.33
-51.8	76.8	-35.82	16.18	28.8	12.62

LTE Band 12 Uplink Gain vs RPCH and BSCL - Middle Channel (Mobile Unit)					
RPCH Power (dBm)	BSCL (dB)	Measured Power (dBm)	Gain (dB)	Limit (dB)	Margin (dB)
-101.7	126.7	4.27	57.44	58	0.56
-91.7	116.7	-34.86	18.31	58	39.69
-81.7	106.7	-34.4	18.77	58	39.23
-71.7	96.7	-34.76	18.41	48.7	30.29
-61.7	86.7	-34.64	18.53	38.7	20.17
-51.7	76.7	-34.81	18.36	28.7	10.34

LTE Band 13 Uplink Gain vs RPCH and BSCL - Middle Channel (Mobile Unit)					
RPCH Power (dBm)	BSCL (dB)	Measured Power (dBm)	Gain (dB)	Limit (dB)	Margin (dB)
-101.6	126.6	4.13	57.61	58	0.87
-91.6	116.6	-35.69	17.48	58	40.52
-81.6	106.6	-35.3	17.87	58	40.73
-71.6	96.6	-35.64	17.53	48.6	31.07
-61.6	86.6	-35.51	17.66	38.6	20.94
-51.6	76.6	-35.31	17.86	28.6	10.74

LTE Band 4 Uplink Gain vs RPCH and BSCL - Middle Channel (Mobile Unit)					
RPCH Power (dBm)	BSCL (dB)	Measured Power (dBm)	Gain (dB)	Limit (dB)	Margin (dB)
-102.6	127.6	10.42	63.59	65	1.41
-92.6	117.6	-36.57	16.6	65	48.4
-82.6	107.6	-36.74	16.43	59.6	43.17
-72.6	97.6	-36.69	16.48	49.6	33.12
-62.6	87.6	-36.52	16.65	39.6	22.95
-52.6	77.6	-36.58	16.59	29.6	13.01

Uplink Gain Timing – Fix Unit				
Band	Frequency (MHz)	UL Gain Timing (Sec)	Limit (Sec)	Margin (Sec)
WCDMA Band 2 Uplink	1880.0	0.723	3	2.277
LTE Band 2 Uplink	1880.0	0.666	3	2.334
WCDMA Band 5 Uplink	836.6	0.593	3	2.407
LTE Band 5 Uplink	836.5	0.593	3	2.407
LTE Band 12 Uplink	707	0.568	3	2.432
LTE Band 13 Uplink	782	0.594	3	2.406
LTE Band 4 Downlink	1732.5	0.622	3	2.378

Uplink Gain Timing – Mobile Unit				
Band	Frequency (MHz)	UL Gain Timing (Sec)	Limit (Sec)	Margin (Sec)
WCDMA Band 2 Uplink	1880.0	0.593	3	2.407
LTE Band 2 Uplink	1880.0	0.622	3	2.378
WCDMA Band 5 Uplink	836.6	0.579	3	2.421
LTE Band 5 Uplink	836.5	0.593	3	2.407
LTE Band 12 Uplink	707	0.565	3	2.435
LTE Band 13 Uplink	782	0.551	3	2.449
LTE Band 4 Downlink	1732.5	0.651	3	2.349

2.9.9 Sample Test Results

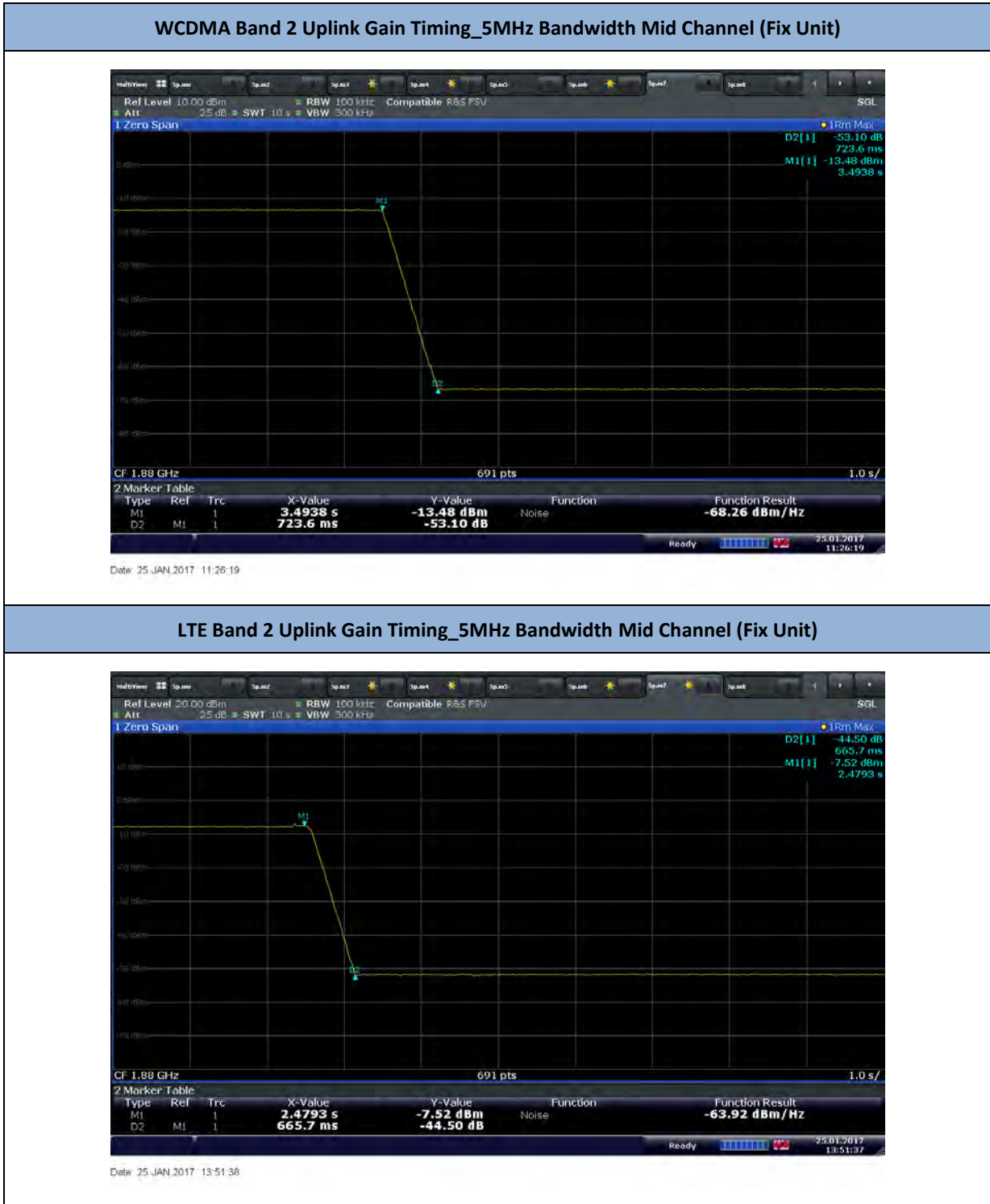

WCDMA Band 5 Uplink Gain Timing_5MHz Bandwidth Mid Channel (Fix Unit)



Date: 25 JAN 2017 13:37:09

LTE Band 5 Uplink Gain Timing_5MHz Bandwidth Mid Channel (Fix Unit)



Date: 25 JAN 2017 13:38:11

LTE Band 12 Uplink Gain Timing_5MHz Bandwidth Mid Channel (Fix Unit)



Date: 25 JAN 2017 14:32:29

LTE Band 13 Uplink Gain Timing_5MHz Bandwidth Mid Channel (Fix Unit)



Date: 25 JAN 2017 14:11:33

LTE Band 4 Uplink Gain Timing_5MHz Bandwidth Mid Channel (Fix Unit)



Date: 25 JAN 2017 13:59:23

2.10 OSCILLATION DETECTION

2.10.1 Specification Reference

FCC 47 CFR Part 20. Clause 20.21(e)(9)(ii)(A)
KDB935210 D04, Clause 7.11.1 & 7.11.2

2.10.2 Standard Applicable

FCC 47 CFR Part 20. Clause 20.21(e)(9)(ii)(A) Anti-Oscillation:
Consumer boosters must be able to detect and mitigate (i.e., by automatic gain reduction or shut down), any oscillations in uplink and downlink bands. Oscillation detection and mitigation must occur automatically within 0.3 seconds in the uplink band and within 1 second in the downlink band. In cases where oscillation is detected, the booster must continue mitigation for at least one minute before restarting. After five such restarts, the booster must not resume operation until manually reset.

2.10.3 Equipment Under Test and Modification State

Serial No: 332633000271, 932703000264 / Test Configuration K and L

2.10.4 Date of Test/Initial of test personnel who performed the test

February 07 and 22, 2017/XYZ

2.10.5 Test Equipment Used

The major items of test equipment used for the above tests are identified in Section 3.1.

2.10.6 Environmental Conditions

Test performed at TÜV SÜD America Inc. Rancho Bernardo facility.

Ambient Temperature	24.6 - 25.4°C
Relative Humidity	42.7 - 48.9%
ATM Pressure	99.5 - 99.6kPa

2.10.7 Additional Observations

- 1) This is conducted Test.
- 2) Test procedure is per Section 7.11.1 and 7.11.2 of KDB935210 (D04 Provider Specific Booster Measurements v02). Appropriate offset (line losses) applied.
- 3) The Fix Unit operated in Normal Mode when testing Oscillation Mitigation Time;
- 4) Setup the EUT according to Figure 10 (uplink) and Figure 11 (downlink) of Section 7.11.2 of KDB935210 (D04 Provider Specific Booster Measurements v02) for Normal Mode.
- 5) The EUT operated in Test Mode when testing Re-Try event;
- 6) The EUT operated in Test Mode when testing Oscillation Mitigation or shut down (The EUT in normal mode doesn't boot up when inject AWGN signal).
- 7) Evaluations are conducted at Server and Donor antenna ports.
- 8) Signal: 5MHz LTE or WCDMA.

2.10.8 Test Results Summary

Band	Frequency (MHz)	Mitigation Time (Sec)	Limit (Sec)	Margin (Sec)
WCDMA Band 2 Downlink	1960	0.028	1	0.972
WCDMA Band 2 Uplink	1880	0.035	0.3	0.265
LTE Band 2 Downlink	1960	0.021	1	0.979
LTE Band 2 Uplink	1880	0.035	0.3	0.265
WCDMA Band 5 Downlink	881.6	0.035	1	0.965
WCDMA Band 5 Uplink	836.6	0.035	0.3	0.265
LTE Band 5 Downlink	881.5	0.021	1	0.979
LTE Band 5 Uplink	836.5	0.028	0.3	0.272
LTE Band 12 Downlink	737.5	0.028	1	0.972
LTE Band 12 Uplink	707.5	0.028	0.3	0.272
LTE Band 13 Downlink	751	0.021	1	0.979
LTE Band 13 Uplink	782	0.035	0.3	0.265
LTE Band 4 Downlink	2145	0.035	1	0.965
LTE Band 4 Uplink	1745	0.035	0.3	0.265

Band	Frequency (MHz)	Re-Try Event	Limit Event	Margin (dB)
WCDMA Band 2 Downlink	1960	0	5	-5
WCDMA Band 2 Uplink	1880	0	5	-5
LTE Band 2 Downlink	1960	0	5	-5
LTE Band 2 Uplink	1880	0	5	-5
WCDMA Band 5 Downlink	881.6	0	5	-5
WCDMA Band 5 Uplink	836.6	0	5	-5
LTE Band 5 Downlink	881.5	0	5	-5
LTE Band 5 Uplink	836.5	0	5	-5
LTE Band 12 Downlink	737.5	0	5	-5
LTE Band 12 Uplink	707.5	0	5	-5
LTE Band 13 Downlink	751	0	5	-5
LTE Band 13 Uplink	782	0	5	-5
LTE Band 4 Downlink	2145	0	5	-5
LTE Band 4 Uplink	1745	0	5	-5

Band	Frequency (MHz)	Peak Oscillation Level (dB)	Limit (dB)	Margin (dB)
WCDMA Band 2 Downlink	1932.4	2.36	12	9.64
WCDMA Band 2 Uplink	1852.4	2.45	12	9.55
LTE Band 2 Downlink	1932.4	3.69	12	8.31
LTE Band 2 Uplink	1852.4	2.94	12	9.06
WCDMA Band 5 Downlink	871.4	4.15	12	7.85
WCDMA Band 5 Uplink	826.4	4.04	12	7.96
LTE Band 5 Downlink	871.5	3.14	12	8.86
LTE Band 5 Uplink	826.5	3.06	12	8.94
LTE Band 12 Downlink	731.5	2.69	12	9.31
LTE Band 12 Uplink	701.5	0.66	12	11.34
LTE Band 13 Downlink	748.5	0.69	12	11.31
LTE Band 13 Uplink	779.5	4.31	12	7.69
LTE Band 4 Downlink	2112.5	3.70	12	8.3
LTE Band 4 Uplink	1712.5	3.25	12	8.75

2.10.9 Test Plots

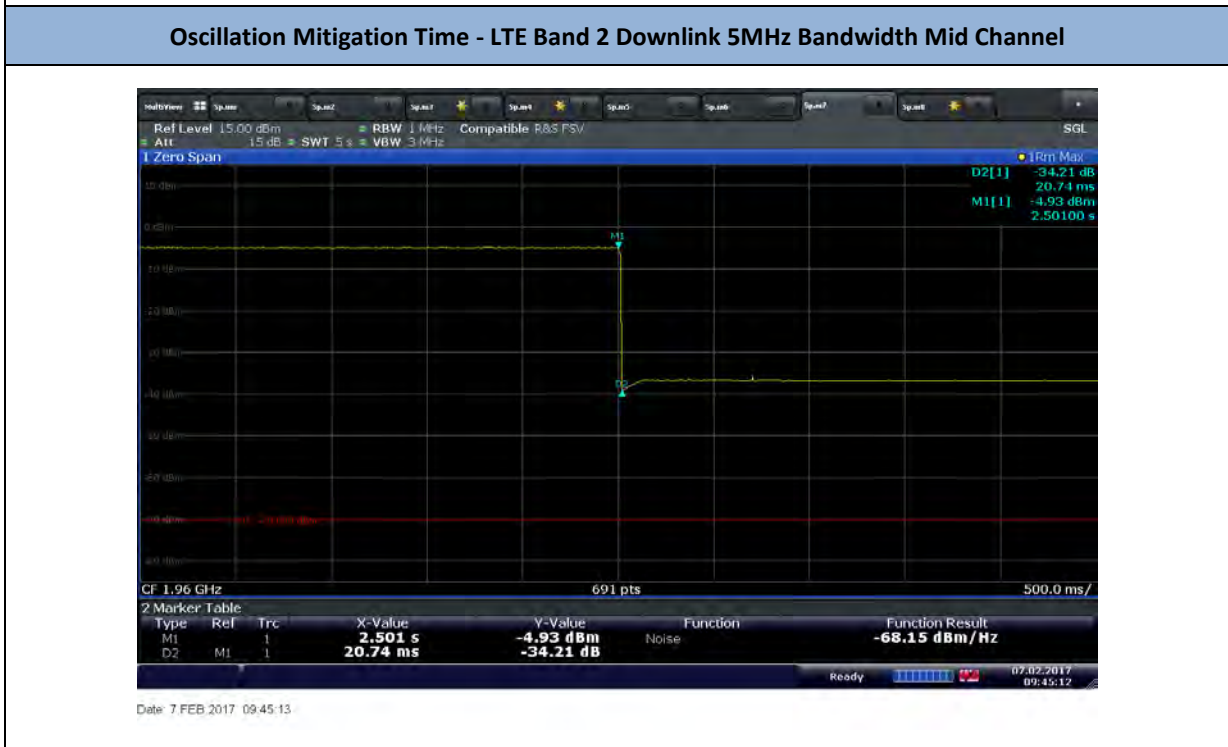
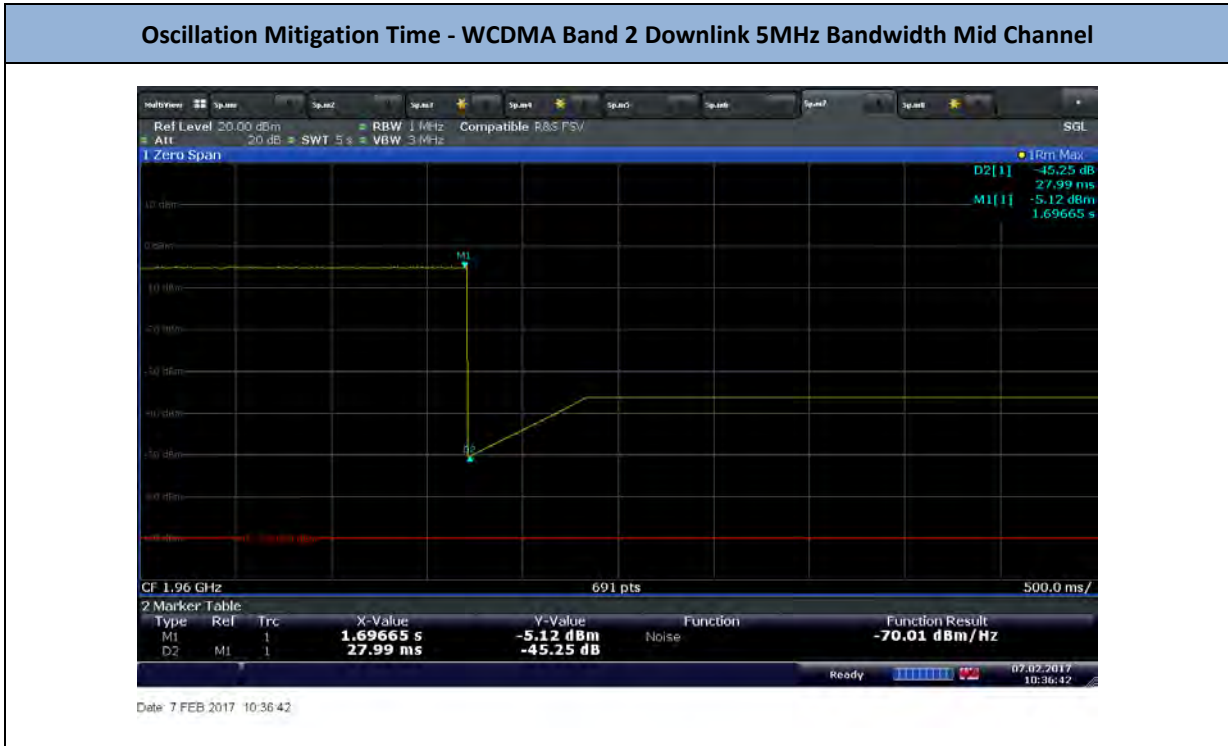

Oscillation Mitigation Time – WCDMA Band 5 Downlink 5MHz Bandwidth Mid Channel



Date: 7 FEB 2017 10:30:01

Oscillation Mitigation Time - LTE Band 5 Downlink 5MHz Bandwidth Mid Channel



Date: 7 FEB 2017 10:27:34

Oscillation Mitigation Time - LTE Band 12 Downlink 5MHz Bandwidth Mid Channel



Date: 7 FEB 2017 10:04:11

Oscillation Mitigation Time - LTE Band 13 Downlink 5MHz Bandwidth Mid Channel



Date: 7 FEB 2017 09:51:38

Oscillation Mitigation Time - LTE Band 4 Downlink 5MHz Bandwidth Mid Channel



Date: 7.FEB.2017 10:19:44

Oscillation Mitigation Time - WCDMA Band 2 Uplink 5MHz Bandwidth Mid Channel



Date: 7.FEB.2017 10:57:44

Oscillation Mitigation Time - LTE Band 2 Uplink 5MHz Bandwidth Mid Channel



Date: 7 FEB 2017 10:54:48

Oscillation Mitigation Time – WCDMA Band 5 Uplink 5MHz Bandwidth Mid Channel



Date: 7 FEB 2017 11:10:40

Oscillation Mitigation Time - LTE Band 5 Uplink 5MHz Bandwidth Mid Channel



Date: 7 FEB 2017 11:06:00

Oscillation Mitigation Time - LTE Band 12 Uplink 5MHz Bandwidth Mid Channel



Date: 7 FEB 2017 11:22:37

Oscillation Mitigation Time - LTE Band 13 Up 5MHz Bandwidth Mid Channel



Date: 7 FEB 2017 11:31:18

Oscillation Mitigation Time - LTE Band 4 Uplink 5MHz Bandwidth Mid Channel



Date: 7 FEB 2017 11:16:11

2.11 MOBILE BOOSTER AUTOMATIC FEEDBACK CANCELLATION

2.11.1 Specification Reference

FCC 47 CFR Part 20. Clause 20.21(e)(9)(i)(C)(2)(iii)
KDB935210 D04, Clause 7.12

2.11.2 Standard Applicable

FCC 47 CFR Part 20. Clause 20.21(e)(9)(i)(C)(2)(iii):
(iii) Mobile Booster maximum gain shall not exceed 15 dB when directly connected (e.g., boosters with a physical connection to the subscriber device), 23 dB when using direct contact coupling (e.g., cradle-type boosters), or 50 dB when using an inside antenna (e.g., inside a vehicle). For systems using an inside antenna that have automatic gain adjustment based on isolation measurements between booster donor and server antenna and automatic feedback cancellation, the mobile booster maximum gain shall not exceed 58 dB and 65 dB for frequencies below and above 1 GHz, respectively.

2.11.3 Equipment Under Test and Modification State

Serial No: 932703000165 / Test Configuration M

2.11.4 Date of Test/Initial of test personnel who performed the test

February 22, 2017/XYZ

2.11.5 Test Equipment Used

The major items of test equipment used for the above tests are identified in Section 3.1.

2.11.6 Environmental Conditions

Test performed at TÜV SÜD America Inc. Rancho Bernardo facility.

Ambient Temperature	25.4°C
Relative Humidity	42.7%
ATM Pressure	99.5kPa

2.11.7 Additional Observations

- 9) This is conducted Test.
- 10) Test procedure is per Section 7.12 of KDB935210 (D04 Provider Specific Booster Measurements v02).
Appropriate offset (line losses) applied.
- 11) The Mobile Unit operated in Test Mode when testing Automatic Feedback Cancellation (The EUT in normal mode doesn't boot up when inject AWGN signal).
- 12) Setup the EUT according to Figure 13 of Section 7.12 of KDB935210 (D04 Provider Specific Booster Measurements v02).
- 13) Evaluations are conducted at Server and Donor antenna ports.
- 14) Signal: 4.1MHz AWGN.

2.11.8 Test Results Summary

Band	Frequency (MHz)	Peak Oscillation Level (dB)	Limit (dB)	Margin (dB)
WCDMA Band 2 Downlink	1932.4	1.0	12	11
WCDMA Band 2 Uplink	1852.4	0.68	12	11.32
LTE Band 2 Downlink	1932.4	1.12	12	10.88
LTE Band 2 Uplink	1852.4	1.16	12	10.84
WCDMA Band 5 Downlink	871.4	0.41	12	11.59
WCDMA Band 5 Uplink	826.4	0.7	12	11.3
LTE Band 5 Downlink	871.5	0.38	12	11.62
LTE Band 5 Uplink	826.5	0.86	12	11.14
LTE Band 12 Downlink	731.5	0.83	12	11.17
LTE Band 12 Uplink	701.5	0.19	12	11.81
LTE Band 13 Downlink	748.5	0.52	12	11.48
LTE Band 13 Uplink	779.5	1.06	12	10.94
LTE Band 4 Downlink	2112.5	1.03	12	10.97
LTE Band 4 Uplink	1712.5	2.43	12	9.57

2.12 OUT OF BAND GAIN LIMIT

2.12.1 Specification Reference

FCC 47 CFR Part 20. Clause 20.21(e)(9)(i)(E)
KDB935210 D04, Clause 7.15

2.12.2 Standard Applicable

FCC 47 CFR Part 20. Clause 20.21(e)(9)(i)(E) Out of Band Gain Limits.:

(1) A frequency selective booster shall have the following minimum attenuation referenced to the gain in the center of the pass band of the booster:

- (i) -20 dB at the band edge, where band edge is the end of the licensee’s allocated spectrum,
- (ii) -30 dB at 1 MHz offset from band edge,
- (iii) -40 dB at 5 MHz offset from band edge.

(2) A frequency selective booster having maximum gain greater than 80 dB (referenced to the center of the pass band) shall limit the out of band gain to 60 dB at 0.2 MHz offset from the band edge, and 45 dB at 1 MHz offset from the band edge, where band edge is the end of the licensee’s allocated spectrum.

2.12.3 Equipment Under Test and Modification State

Serial No: 332633000356 / Test Configuration A and B

2.12.4 Date of Test/Initial of test personnel who performed the test

January 19, 2017 /XYZ

2.12.5 Test Equipment Used

The major items of test equipment used for the above tests are identified in Section 3.1.

2.12.6 Environmental Conditions/ Test Location

Test performed at TÜV SÜD America Inc. Rancho Bernardo facility

Ambient Temperature	21.1°C
Relative Humidity	59.6%
ATM Pressure	99.2kPa

2.12.7 Additional Observations

- 1) This is conducted Test. Test procedure is per Section 7.15 of KDB935210 (D04 Provider Specific Booster Measurements v02). Appropriate offset (line losses) applied.
- 2) The Fix Unit operated in Test Mode with the gain manually set to the maximum gain and a minimum bandwidth setting (5MHz).
- 3) Setup the EUT according to Figure 2 or 3 of Section 6.3.3 of KDB935210 (D04 Provider Specific Booster Measurements v02) as appropriate.
- 4) Evaluations are conducted at Server and Donor antenna ports.
- 5) Operational uplink and downlink bands for WCDMA Band 2, 5, and LTE Band 2, 5, 12, 13 and 4 were tested.
- 6) The signal generator was set to transmit a CW signal with output power level set to that as determined in clause 7.1.2 of KDB935210 (D04 Provider Specific Booster Measurements v02).

2.12.8 Test Results

Out of Band Gain Limit				
WCDMA Band 2 Downlink (1930 – 1990MHz)				
Offset (MHz)	Input Power (dBm)	Output Power (dBm)	Gain (dB)	Gain Limit (dB)
Centre Frequency	-79.10	1.26	80.36	-
0 (Low Band Edge)	-78.94	-52.97	25.97	60.36
-0.2	-78.86	-55.15	23.71	60
-1	-78.74	-54.23	24.51	45
-5	-79.30	-62.16	17.14	40.36
0 (High Band Edge)	-78.62	-58.46	20.16	60.36
+0.2	-78.72	-55.82	22.9	60
+1	-78.64	-60.77	17.87	45
+5	-79.11	-60.81	18.3	40.36

Out of Band Gain Limit WCDMA Band 2 Uplink (1850 – 1910MHz)				
Offset (MHz)	Input Power (dBm)	Output Power (dBm)	Gain (dB)	Gain Limit (dB)
Centre Frequency	-71.38	11.80	83.18	-
0 (Low Band Edge)	-71.50	-66.82	4.68	63.18
-0.2	-71.37	-68.45	2.92	60
-1	-71.63	-68.69	2.94	45
-5	-71.62	-68.64	2.98	43.18
0 (High Band Edge)	-71.41	-68.56	2.85	63.18
+0.2	-71.55	-68.81	2.74	60
+1	-71.45	-68.52	2.93	45
+5	-71.47	-68.88	2.59	43.18

Out of Band Gain Limit LTE Band 2 Downlink (1930 – 1990MHz)				
Offset (MHz)	Input Power (dBm)	Output Power (dBm)	Gain (dB)	Gain Limit (dB)
Centre Frequency	-80.84	9.29	90.13	-
0 (Low Band Edge)	-80.57	-56.85	23.72	70.13
-0.2	-80.24	-54.07	26.17	60
-1	-80.31	-56.60	23.71	45
-5	-80.4	-55.80	24.6	50.13
0 (High Band Edge)	-80.82	-57.48	23.34	70.13
+0.2	-80.37	-56.44	23.93	60
+1	-80.24	-58.7	21.54	45
+5	-80.85	-55.88	24.97	50.13

Out of Band Gain Limit LTE Band 2 Uplink (1850 – 1910MHz)				
Offset (MHz)	Input Power (dBm)	Output Power (dBm)	Gain (dB)	Gain Limit (dB)
Centre Frequency	-70.55	11.21	81.76	-
0 (Low Band Edge)	-70.58	-68.15	2.43	61.76
-0.2	-70.44	-68.47	1.97	60
-1	-70.63	-68.39	2.24	45
-5	-70.61	-68.78	1.83	41.76
0 (High Band Edge)	-70.58	-67.89	2.69	61.76
+0.2	-70.52	-68.25	2.27	60
+1	-70.5	-68.04	2.46	45
+5	-70.54	-67.26	3.28	41.76

Out of Band Gain Limit WCDMA Band 5 Downlink (869– 894MHz)				
Offset (MHz)	Input Power (dBm)	Output Power (dBm)	Gain (dB)	Gain Limit (dB)
Centre Frequency	-80.46	6.25	86.71	-
0 (Low Band Edge)	-80.83	-66.60	14.23	66.71
-0.2	-80.18	-66.65	13.53	60
-1	-80.42	-66.63	13.79	45
-5	-80.42	-65.79	14.63	46.71
0 (High Band Edge)	-80.34	-66.16	14.18	66.71
+0.2	-80.70	-67.29	13.41	60
+1	-80.28	-66.17	14.11	45
+5	-80.21	-67.88	12.33	46.71

Out of Band Gain Limit WCDMA Band 5 Uplink (824 – 849MHz)				
Offset (MHz)	Input Power (dBm)	Output Power (dBm)	Gain (dB)	Gain Limit (dB)
Centre Frequency	-70.09	4.74	74.83	-
0 (Low Band Edge)	-70.39	-66.92	3.47	54.83
-0.2	-69.64	-67.01	2.63	60
-1	-70.20	-65.44	4.76	45
-5	-70.17	-67.54	2.63	34.83
0 (High Band Edge)	-70.01	-68.05	1.96	54.83
+0.2	-69.85	-66.89	2.96	60
+1	-69.46	-65.63	3.83	45
+5	-69.83	-66.66	3.17	34.83

Out of Band Gain Limit LTE Band 5 Downlink (869– 894MHz)				
Offset (MHz)	Input Power (dBm)	Output Power (dBm)	Gain (dB)	Gain Limit (dB)
Centre Frequency	-79.39	1.56	80.95	-
0 (Low Band Edge)	-79.49	-66.31	13.18	60.95
-0.2	-79.57	-67.14	12.43	60
-1	-79.59	-65.02	14.57	45
-5	-79.42	-67.36	12.06	40.95
0 (High Band Edge)	-79.50	-67.00	12.5	60.95
+0.2	-79.66	-67.24	12.42	60
+1	-79.79	-67.29	12.5	45
+5	-79.68	-66.77	12.91	40.95

Out of Band Gain Limit LTE Band 5 Uplink (824 – 849MHz)				
Offset (MHz)	Input Power (dBm)	Output Power (dBm)	Gain (dB)	Gain Limit (dB)
Centre Frequency	-70.09	6.88	76.97	-
0 (Low Band Edge)	-70.39	-67.23	3.16	56.97
-0.2	-69.64	-66.47	3.17	60
-1	-70.20	-65.85	4.35	45
-5	-70.17	-67.54	2.63	36.97
0 (High Band Edge)	-70.01	-66.71	3.3	56.97
+0.2	-69.85	-66.69	3.16	60
+1	-69.46	-66.41	3.05	45
+5	-69.83	-65.32	4.51	36.97

Out of Band Gain Limit LTE Band 12 Downlink (729 – 746MHz)				
Offset (MHz)	Input Power (dBm)	Output Power (dBm)	Gain (dB)	Gain Limit (dB)
Centre Frequency	-78.91	6.98	85.89	-
0 (Low Band Edge)	-78.95	-66.33	12.62	65.89
-0.2	-78.84	-65.26	13.58	60
-1	-78.66	-66.21	12.45	45
-5	-78.46	-69.11	9.35	45.89
0 (High Band Edge)	-78.56	-65.47	13.09	65.89
+0.2	-78.94	-66.76	12.18	60
+1	-78.99	-66.59	12.4	45
+5	-78.92	-66.76	12.16	45.89

Out of Band Gain Limit LTE Band 12 Uplink (699 – 716MHz)				
Offset (MHz)	Input Power (dBm)	Output Power (dBm)	Gain (dB)	Gain Limit (dB)
Centre Frequency	-70.17	8.38	78.55	-
0 (Low Band Edge)	-70.01	-67.27	2.74	58.55
-0.2	-70.23	-67.39	2.84	60
-1	-70.06	-67.14	2.92	45
-5	-69.89	-68.13	1.76	38.55
0 (High Band Edge)	-69.72	-67.12	2.6	58.55
+0.2	-69.92	-67.27	2.65	60
+1	-69.82	-66.58	3.24	45
+5	-69.77	-68.90	0.87	38.55

Out of Band Gain Limit LTE Band 13 Downlink (746 – 756MHz)				
Offset (MHz)	Input Power (dBm)	Output Power (dBm)	Gain (dB)	Gain Limit (dB)
Centre Frequency	-78.67	9.20	87.87	-
0 (Low Band Edge)	-78.76	-66.98	11.78	67.87
-0.2	-78.93	-66.19	12.74	60
-1	-78.80	-66.51	12.29	45
-5	-78.62	-68.11	10.51	47.87
0 (High Band Edge)	-79.12	-66.38	12.74	67.87
+0.2	-78.85	-67.13	11.72	60
+1	-78.98	-67.23	11.75	45
+5	-78.90	-68.39	10.51	47.87

Out of Band Gain Limit				
LTE Band 13 Uplink (777 – 787MHz)				
Offset (MHz)	Input Power (dBm)	Output Power (dBm)	Gain (dB)	Gain Limit (dB)
Centre Frequency	-70.33	5.01	75.34	-
0 (Low Band Edge)	-69.88	-66.67	3.21	55.34
-0.2	-69.96	-66.08	3.88	60
-1	-69.83	-67.91	1.92	45
-5	-69.83	-68.79	1.04	35.34
0 (High Band Edge)	-70.09	-65.04	5.05	55.34
+0.2	-70.01	-64.70	5.31	60
+1	-70.17	-65.23	4.94	45
+5	-69.86	-68.80	1.06	35.34

Out of Band Gain Limit				
LTE Band 4 Downlink (2110 – 2155MHz)				
Offset (MHz)	Input Power (dBm)	Output Power (dBm)	Gain (dB)	Gain Limit (dB)
Centre Frequency	-80.68	8.57	89.25	-
0 (Low Band Edge)	-80.27	-60.34	19.93	69.25
-0.2	-80.47	-58.32	22.15	60
-1	-80.80	-58.85	21.95	45
-5	-80.56	-60.04	20.52	49.25
0 (High Band Edge)	-80.65	-59.11	21.54	69.25
+0.2	-80.82	-58.82	22	60
+1	-80.77	-59.69	21.08	45
+5	-80.53	-58.69	21.84	49.25

Out of Band Gain Limit Band 4 Uplink (1710 – 1755MHz)				
Offset (MHz)	Input Power (dBm)	Output Power (dBm)	Gain (dB)	Gain Limit (dB)
Centre Frequency	-71.03	11.66	82.69	-
0 (Low Band Edge)	-71.59	-67.68	3.91	62.69
-0.2	-71.76	-67.62	4.14	60
-1	-71.68	-65.84	5.84	45
-5	-71.73	-67.77	3.96	42.69
0 (High Band Edge)	-71.57	-66.76	4.81	62.69
+0.2	-71.46	-65.96	5.5	60
+1	-71.48	-64.88	6.6	45
+5	-71.39	-65.87	5.52	42.69

SECTION 3

TEST EQUIPMENT USED

3.1 TEST EQUIPMENT USED

List of absolute measuring and other principal items of test equipment.

ID Number (SDGE/SDRB)	Test Equipment	Type	Serial Number	Manufacturer	Cal Date	Cal Due Date
Antenna Conducted Port Setup						
7604	P-Series Power Meter	N1912A	SG45100273	Agilent	07/27/16	07/27/17
7605	50MHz-18GHz Wideband Power Sensor	N1921A	MY51100054	Agilent	04/19/16	04/19/17
7582	Signal/Spectrum Analyzer	FSW26	101614	Rhode & Schwarz	10/26/16	10/26/17
7608	Vector Signal Generator	SMBV100A	259021	Rhode & Schwarz	09/02/16	09/02/17
7610	DFS Radar Simulator and Analyzer*	Aeroflex 3005	30050A/09L	Aeroflex international LTD. UK	06/30/16	06/30/17
9063	Universal Radio Communication	CMW200	1400-38269	Rhode & Schwarz	For Signal Only	
7562	Wideband Radio Communication Tester	CMW 500	1201.0002k50 /103829	Rhode & Schwarz	For Signal Only	
-	Feedback Attenuator	RSP	834500/009	Rhode & Schwarz	Verified by 7582 and 7608	
-	11dB Step Attenuator	8494B	2812A17193	Agilent	Verified by 7582 and 7608	
-	110 dB Step Attenuator	8496B	MY42143874	Agilent	Verified by 7582 and 7608	
8825	20dB Attenuator	46-20-34	BK5773	Weinschel Corp.	Verified by 7582 and 7608	
-	10dB Attenuator	PE7010-10	-	Pasternack	Verified by 7582 and 7608	
-	3dB Attenuator	PE7010-6	-	Pasternack	Verified by 7582 and 7608	
Miscellaneous						
6792	Multimeter	3478A	2911A70964	Hewlett Packard	08/29/16	08/29/17
11312	Mini Environmental Quality Meter	850027	CF099-56010-340	Sper Scientific	08/22/16	08/22/17
	Test Software	EMC32	V8.53	Rhode & Schwarz	N/A	

3.2 MEASUREMENT UNCERTAINTY

For a 95% confidence level, the measurement uncertainties for defined systems are:

3.2.1 General Direct Conducted Antenna Port Measurement

Contribution		Probability Distribution Type	Probability Distribution x_i	Standard Uncertainty $u(x_i)$	$[u(x_i)]^2$
1	Receiver/Spectrum Analyzer	Rectangular	0.34	0.20	0.04
2	Cables	Rectangular	1.00	0.58	0.33
3	EUT Setup	Rectangular	0.50	0.29	0.08
Combined Uncertainty (u_c):					0.67
Coverage Factor (k):					1.96
Expanded Uncertainty:					1.32

SECTION 4

DIAGRAM OF TEST SETUP

4.1 TEST SETUP DIAGRAM

Notes: All tests were done on the bench (conducted). Please refer to Section 1.4.4 of this test report for more details.

SECTION 5

ACCREDITATION, DISCLAIMERS AND COPYRIGHT

5.1 ACCREDITATION, DISCLAIMERS AND COPYRIGHT

TÜV SÜD America Inc.'s reports apply only to the specific sample tested under stated test conditions. It is the manufacturer's responsibility to assure the continued compliance of production units of this model. TÜV SÜD America, Inc. shall have no liability for any deductions, inferences or generalizations drawn by the client or others from TÜV SÜD America, Inc.'s issued reports.

This report is the confidential property of the client. As a mutual protection to our clients, the public and TÜV SÜD America, Inc., extracts from the test report shall not be reproduced, except in full without TÜV SÜD America, Inc.'s written approval.

This report must not be used to claim product certification, approval, or endorsement by A2LA, NIST, or any agency of the federal government.

TÜV SÜD America, Inc. and its professional staff hold government and professional organization certifications for AAMI, ACIL, AEA, ANSI, IEEE, A2LA, NIST and VCCI.



A2LA Cert. No. 2955.13

The NIST logo is the text 'NIST' in a bold, black, sans-serif font.

