

FCC Test Report

Product Name	Mobile Tablet
Model No.	DT317BT
FCC ID	YE3800H

Applicant	DT Research, Inc.
Address	6F, No. 1, NingPo E. St. Taipei, 100 Taiwan

Date of Receipt	Jan. 05, 2017
Issued Date	Feb. 07, 2017
Report No.	1710172R-RFUSP17V00
Report Version	V1.0



The test results relate only to the samples tested.

The test results shown in the test report are traceable to the national/international standard through the calibration report of the equipment and evaluated measurement uncertainty herein.

This report must not be used to claim product endorsement by TAF or any agency of the government.

The test report shall not be reproduced without the written approval of DEKRA Testing and Certification Co., Ltd.

Test Report

Issued Date: Feb. 07, 2017

Report No.: 1710172R-RFUSP17V00



Product Name	Mobile Tablet
Applicant	DT Research, Inc.
Address	6F, No. 1, NingPo E. St. Taipei, 100 Taiwan
Manufacturer	DT Research, Inc.
Model No.	DT317BT
FCC ID.	YE3800H
EUT Rated Voltage	AC 100-240V, 50-60Hz
EUT Test Voltage	AC 120V/60Hz
Trade Name	DT Research, Inc.
Applicable Standard	FCC CFR Title 47 Part 15 Subpart C: 2015 ANSI C63.4: 2014, ANSI C63.10: 2013
Test Result	Complied

Documented By :



(Senior Adm. Specialist / Rita Huang)

Tested By :

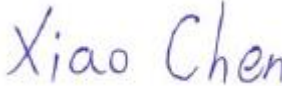

(Engineer / Xiao Chen)

Approved By :



(Director / Vincent Lin)

TABLE OF CONTENTS

Description	Page
1. GENERAL INFORMATION	4
1.1. EUT Description.....	4
1.2. Operational Description	5
1.3. Tested System Details	6
1.4. Configuration of tested System	6
1.5. EUT Exercise Software	6
1.6. Test Facility	7
2. Conducted Emission.....	9
2.1. Test Setup.....	9
2.2. Limits	10
2.3. Test Procedure.....	10
2.4. Uncertainty.....	10
2.5. Test Result of Conducted Emission.....	11
3. Radiated Emission.....	13
3.1. Test Setup.....	13
3.2. Limits	14
3.3. Test Procedure.....	15
3.4. Uncertainty.....	16
3.5. Test Result of Radiated Emission.....	17
4. Band Edge	25
4.1. Test Setup.....	25
4.2. Limits	26
4.3. Test Procedure.....	26
4.4. Uncertainty.....	26
4.5. Test Result of Band Edge	27
5. Frequency Tolerance	28
5.1. Test Setup.....	28
5.2. Limits	28
5.3. Test Procedure.....	28
5.4. Uncertainty.....	28
5.5. Test Result of Frequency Stability	29
6. EMI Reduction Method During Compliance Testing	31
Attachment 1: EUT Test Photographs	
Attachment 2: EUT Detailed Photographs	

1. GENERAL INFORMATION

1.1. EUT Description

Product Name	Mobile Tablet
Trade Name	DT Research, Inc.
Model No.	DT317BT
FCC ID	YE3800H
Frequency Range	13.56MHz
Modulation	ASK
Antenna Type	Loop Antenna
Power Adapter	MFR: ENG, M/N: 6A-181WP05 Input: 100-240V~ 0.6A, 50-60Hz Output: 5V $\overline{=}$ 3A Cable out: Non-Shielded, 1.4m, with one ferrite core bonded.

Frequency of Each Channel:

Channel	Frequency
Channel 1:	13.56 MHz

Note:

1. This device is a Mobile Tablet with built-in 13.56MHz transceiver.
2. These tests were conducted on a sample of the equipment for the purpose of demonstrating compliance with Part 15 Subpart C Paragraph 15.225
3. The radiation measurements are performed in X, Y, Z axis positioning. Only the worst case is shown in the report.

Test Mode	Mode 1: Transmit
-----------	------------------

1.3. Tested System Details

The types for all equipment, plus descriptions of all cables used in the tested system (including inserted cards) are:

	Product	Manufacturer	Model No.	Serial No.	Power Cord
1	Keyboard	Logitech	Y-UR83	SY848UK	N/A
2	Earphone	Dr.AV	CD-806B	N/A	N/A

Signal Cable Type	Signal cable Description
A Keyboard Cable	Non-Shielded, 1.8m
B Earphone Cable	Non-Shielded, 1.0m

1.4. Configuration of tested System

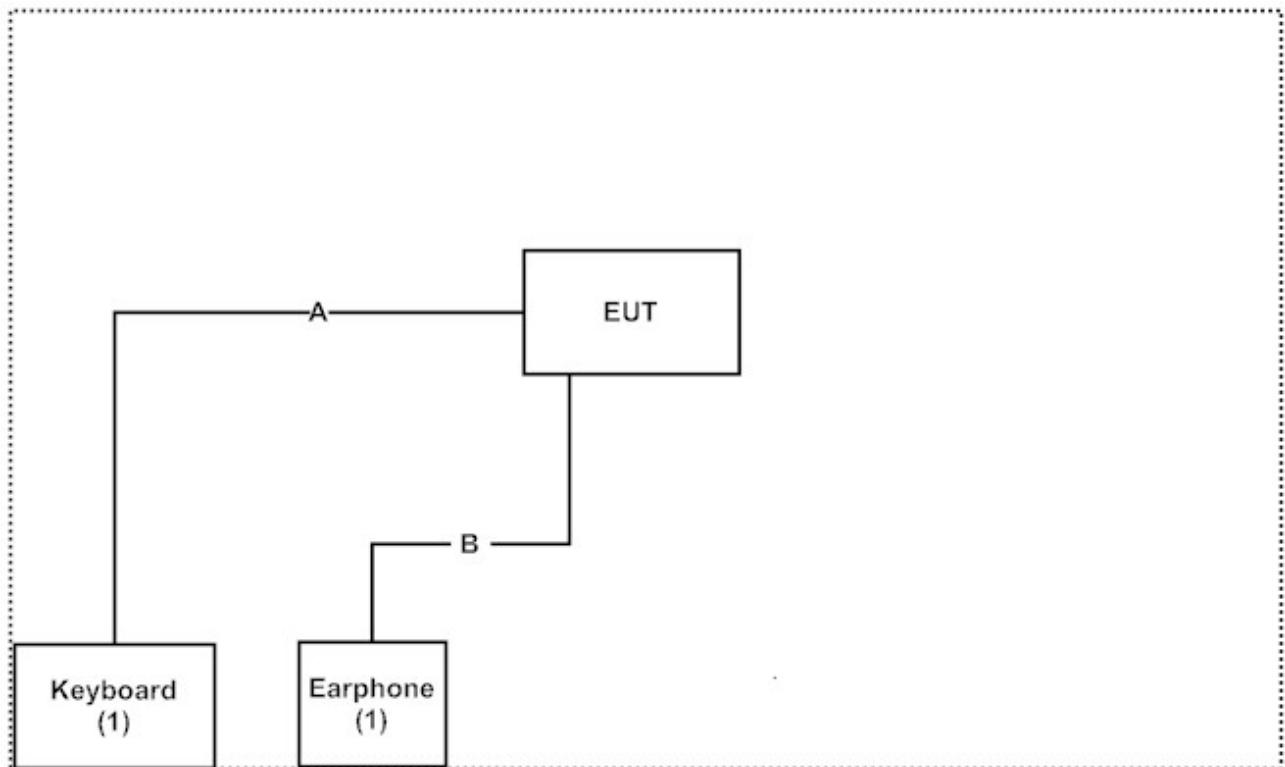

1.5. EUT Exercise Software

- (1) Setup the EUT as shown in Section 1.4
- (2) Turn on the power of all equipment.
- (3) Start the continuous transmitter.
- (4) Verify that the EUT works properly.

1.6. Test Facility

Ambient conditions in the laboratory:

Items	Required (IEC 68-1)	Actual
Temperature (°C)	15-35	20-35
Humidity (%RH)	25-75	50-65
Barometric pressure (mbar)	860-1060	950-1000

The related certificate for our laboratories about the test site and management system can be downloaded from DEKRA Testing and Certification Co., Ltd. Web Site:

<http://www.dekra.com.tw/english/about/certificates.aspx?bval=5>

The address and introduction of DEKRA Testing and Certification Co., Ltd. laboratories can be founded in our Web site: http://www.dekra.com.tw/index_en.aspx

Site Description: Accredited by TAF
Accredited Number: 3023

Site Name: DEKRA Testing and Certification Co., Ltd
Site Address: No.5-22, Ruishukeng, Linkou Dist., New Taipei City 24451,
Taiwan, R.O.C.
TEL : 886-2-8601-3788 / FAX : 886-2-8601-3789
E-Mail : info.tw@dekra.com

FCC Accreditation Number: TW1014

1.7. List of Test Equipment

For Conducted measurements /CB3/SR8

	Equipment	Manufacturer	Model No.	Serial No.	Cali. Data	Due. Data
	Temperature Chamber	WIT GROUP	TH-1S-B	EQ-201-00146	2016/11/28	2017/11/27
X	Spectrum Analyzer	Agilent	N9010A	MY48030495	2016/7/22	2017/7/21
X	Power Meter	Anritsu	ML2495A	6K00003357	2016/6/23	2017/6/22
X	Pulse power sensor	Anritsu	MA2411B	0846193	2016/6/23	2017/6/22
X	EMI Test Receiver	R&S	ESCS 30	100369	2016/10/13	2017/10/12
X	LISN	R&S	ESH3-Z5	836679/017	2017/1/7	2018/1/6
X	LISN	R&S	ENV216	100097	2017/1/7	2018/1/6
X	Coaxial Cable	QTK(Arnist)	RG 400	LC018-RG	2016/6/25	2017/6/24

For Radiated measurements /Site3/CB8

	Equipment	Manufacturer	Model No.	Serial No.	Cali. Data	Due. Data
X	Spectrum Analyzer	R&S	FSP40	100170	2017/1/5	2018/1/4
X	Loop Antenna	Teseq	HLA6121	37133	2016/3/18	2017/3/17
X	Bi-Log Antenna	Schaffner Chase	CBL6112B	2707	2016/6/11	2017/6/10
	<u>Horn Antenna</u>	ETS-Lindgren	3117	00135205	2016/4/6	2017/4/5
	<u>Horn Antenna</u>	Schwarzbeck	BBHA9170	9170430	2017/1/11	2018/1/10
X	<u>Pre-Amplifier</u>	QTK	AP/0100A	CHM/0901069	2016/6/23	2017/6/22
	<u>Pre-Amplifier</u>	EMCI	EMC012630SE	980210	2017/1/26	2018/1/24
	<u>Pre-Amplifier</u>	NARDA WE	DBL-1840N506	013	2016/9/30	2017/9/29
	Filter	MicroTRON	BRM50701	019	2016/11/2	2017/11/1
	Filter	Microwave Circuits	N0257881	36681	2016/12/7	2017/12/6
X	EMI Test Receiver	R&S	ESR26	101385	2016/9/29	2017/9/28
X	Coaxial Cable	QTK(Arnist)	SUCOFLEX 106	L1606-015C	2016/6/23	2017/6/22
X	EMI Test Receiver	R&S	ESCS 30	838251/001	2016/7/21	2017/7/20
X	Coaxial Cable	QTK(Arnist)	RG 214	LC003-RG	2016/6/16	2017/6/15
X	Coaxial signal switch	Anritsu	MP59B	6201415889	2016/6/16	2017/6/15

Note:

1. All equipments are calibrated every one year.
2. The test instruments marked with "X" are used to measure the final test results.

Test Software version :QuieTek EMI 2.0 V2.1.113.

2. Conducted Emission

2.1. Test Setup

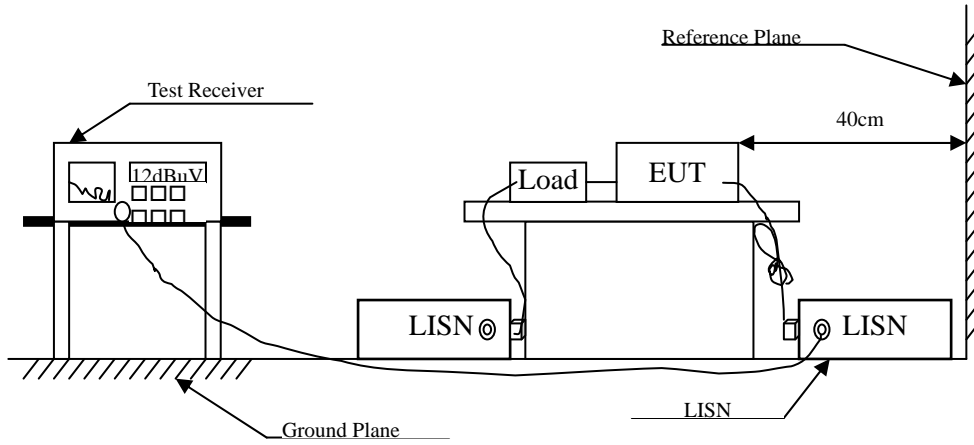

2.2. Limits

FCC Part 15 Subpart C Paragraph 15.207 (dBUV) Limit		
Frequency MHz	Limits	
	QP	AV
0.15 - 0.50	66-56 ^(註)	56-46 ^(註)
0.50-5.0	56	46
5.0 - 30	60	50

2.3. Test Procedure

The EUT and simulators are connected to the main power through a line impedance stabilization network (L.I.S.N.). This provides a 50 ohm /50uH coupling impedance for the measuring equipment. The peripheral devices are also connected to the main power through a LISN that provides a 50ohm /50uH coupling impedance with 50ohm termination. (Please refers to the block diagram of the test setup and photographs.)

Both sides of A.C. line are checked for maximum conducted interference. In order to find the maximum emission, the relative positions of equipment and all of the interface cables must be changed according to ANSI C63.4: 2014 on conducted measurement.

Conducted emissions were investigated over the frequency range from 0.15MHz to 30MHz using a receiver bandwidth of 9kHz.

2.4. Uncertainty

± 2.26 dB

2.5. Test Result of Conducted Emission

Product : Mobile Tablet
 Test Item : Conducted Emission Test
 Power Line : Line 1
 Test date : 2017/02/06
 Test Mode : Mode 1: Transmit

Frequency MHz	Correct Factor dB	Reading Level dBuV	Measurement Level dBuV	Margin dB	Limit dBuV
LINE 1					
Quasi-Peak					
0.197	9.676	41.120	50.796	-13.861	64.657
0.255	9.678	34.280	43.958	-19.042	63.000
0.345	9.681	25.720	35.401	-25.028	60.429
1.841	9.738	20.410	30.148	-25.852	56.000
3.205	9.769	16.100	25.869	-30.131	56.000
13.560	9.935	40.530	50.465	-9.535	60.000
Average					
0.197	9.676	22.150	31.826	-22.831	54.657
0.255	9.678	19.520	29.198	-23.802	53.000
0.345	9.681	5.620	15.301	-35.128	50.429
1.841	9.738	10.250	19.988	-26.012	46.000
3.205	9.769	21.460	31.229	-14.771	46.000
13.560	9.935	30.250	40.185	-9.815	50.000

Note:

1. All Reading Levels are Quasi-Peak and average value.
2. "■" means the worst emission level.
3. Measurement Level = Reading Level + Correct Factor

Product : Mobile Tablet
 Test Item : Conducted Emission Test
 Power Line : Line 2
 Test date : 2017/02/06
 Test Mode : Mode 1: Transmit

Frequency MHz	Correct Factor dB	Reading Level dBuV	Measurement Level dBuV	Margin dB	Limit dBuV
LINE 2					
Quasi-Peak					
0.177	9.659	44.140	53.799	-11.430	65.229
0.259	9.658	31.900	41.558	-21.328	62.886
0.685	9.672	20.530	30.202	-25.798	56.000
1.263	9.700	19.960	29.660	-26.340	56.000
7.748	9.856	17.360	27.216	-32.784	60.000
13.560	9.985	39.020	49.005	-10.995	60.000
Average					
0.177	9.659	27.410	37.069	-18.160	55.229
0.259	9.658	15.820	25.478	-27.408	52.886
0.685	9.672	7.550	17.222	-28.778	46.000
1.263	9.700	9.180	18.880	-27.120	46.000
7.748	9.856	10.700	20.556	-29.444	50.000
13.560	9.985	21.535	31.520	-18.480	50.000

Note:

1. All Reading Levels are Quasi-Peak and average value.
2. “█” means the worst emission level.
3. Measurement Level = Reading Level + Correct Factor

3. Radiated Emission

3.1. Test Setup

9kHz~30MHz

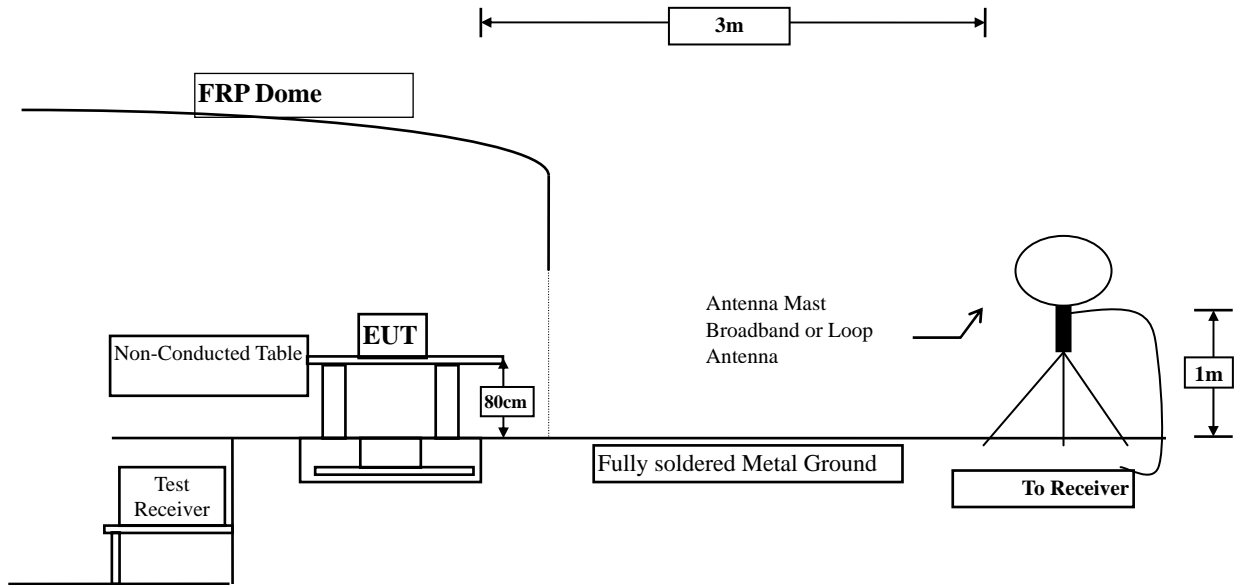

30MHz~1GHz

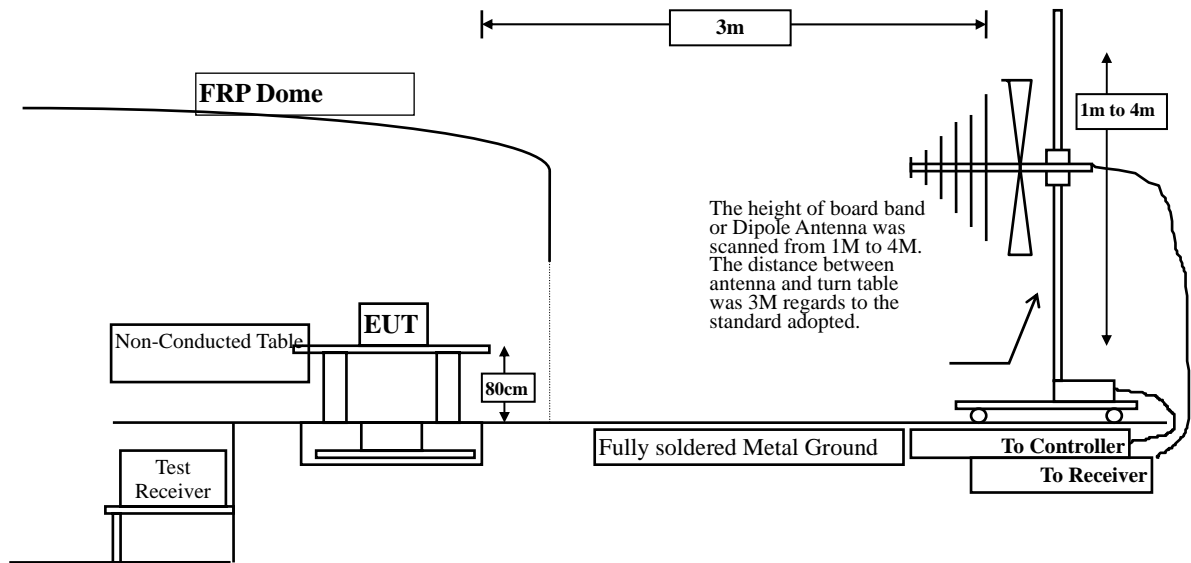

3.2. Limits

➤ Fundamental electric field strength Limit

FCC Part 15 Subpart C Paragraph 15.225 Limits				
Fundamental Frequency MHz	Field strength of fundamental			
	uV/m	Distance (meter)	dBuV/m	Distance (meter)
13.553 – 13.567	15848	30	124	3
13.410 – 13.553 and 13.567 – 13.710	334	30	90.47	3
13.110 – 13.410 and 13.710 – 14.010	106	30	80.50	3
Outside of the 13.110 – 14.010	See 15.209 Limits			

Remarks : 1. RF Voltage (dBuV) = 20 log RF Voltage (uV)

2. Distance refers to the distance in meters between the measuring instrument antenna and the closed point of any part of the device or system.

3. The emission limit in this paragraph is based on measurement instrumentation employing an average detector.

► Spurious electric field strength Limit

FCC Part 15 Subpart C Paragraph 15.209 Limits			
Frequency MHz	uV/m	dBuV/m	Measurement distance (meter)
0.009-0.490	2400/F(kHz)	See Remark ¹	300
0.490-1.705	24000/F(kHz)	See Remark ¹	30
1.705-30	30	29.5	30
30-88	100	40	3
88-216	150	43.5	3
216-960	200	46	3
Above 960	500	54	3

Remarks :

1. RF Voltage (dBuV) = 20 log RF Voltage (uV)
2. In the Above Table, the tighter limit applies at the band edges.
3. Distance refers to the distance in meters between the measuring instrument antenna and the closed point of any part of the device or system.

3.3. Test Procedure

Fundamental electric field strength:

The EUT and its simulators are placed on a turn table which is 1 meter above ground. The turn table can rotate 360 degrees to determine the position of the maximum electric field strength.

The EUT was positioned such that the distance from antenna to the EUT was 3 meters.

The antenna which is 1 meter above ground. All X-axis, Y-axis and Z-axis polarization of the antenna are set on measurement.

Spurious electric field strength:

The EUT and its simulators are placed on a turn table which is 0.8 meter above ground. The turn table can rotate 360 degrees to determine the position of the maximum emission level.

The antenna can move up and down between 1 meter and 4 meters to find out the maximum emission level. The EUT was positioned such that the distance from antenna to the EUT was 3 meters.

Both horizontal and vertical polarization of the antenna are set on measurement. In order to find the maximum emission, all of the interface cables must be manipulated according to ANSI C6310: 2013 on radiated measurement.

On any frequency the radiated limits shown are based upon the use of measurement instrumentation employing an average detector function. When average radiated emission measurement are included emission measurement below 1000 MHz, there also is a limit on the radio frequency emissions, as

measured using instrumentation with a peak detector function, corresponding to 20 dB above the maximum permitted average limit.

The bandwidth below 30MHz setting on the field strength meter is 9kHz and above 30MHz is 120kHz.

The frequency range from 9kHz to 10th harmonics is checked.

3.4. Uncertainty

± 4.08 dB above 1GHz

± 4.22 dB below 1GHz

3.5. Test Result of Radiated Emission

Product : Mobile Tablet
 Test Item : Fundamental Radiated Emission
 Test Site : No.3 OATS
 Test date : 2017/02/06
 Test Mode : Mode 1: Transmit- X-axis

Frequency MHz	Correct Factor dB	Reading Level dBuV	Measurement Level dBuV/m	Margin dB	Limit dBuV/m
X-axis					
Quasi-Peak					
Horizontal					
13.110	20.020	13.048	33.068	-36.432	69.500
13.410	20.020	14.986	35.006	-45.494	80.500
13.553	20.020	18.925	38.945	-51.555	90.500
13.560	20.020	21.661	41.681	-82.319	124.000
13.567	20.020	16.107	36.127	-54.373	90.500
13.710	20.020	13.828	33.848	-46.652	80.500
14.010	20.020	13.421	33.441	-36.059	69.500
Vertical					
13.110	20.020	13.483	33.503	-35.997	69.500
13.410	20.020	15.901	35.921	-44.579	80.500
13.553	20.020	15.531	35.551	-54.949	90.500
13.560	20.020	18.555	38.575	-85.425	124.000
13.567	20.020	16.107	36.127	-54.373	90.500
13.710	20.020	13.567	33.587	-46.913	80.500
14.010	20.020	13.053	33.073	-36.427	69.500

Note:

1. Limit=84dBuV/m + 40*Log (30(m)/3(m))=124dBuV/m
2. All Readings below 1GHz are Quasi-Peak, above are average value.
3. Measurement Level = Reading Level + Correct Factor.
4. The average measurement was not performed when the peak measured data under the limit of average detection. If the readings given are average, peak measurement should also be supplied.

Horizontal (X-axis)

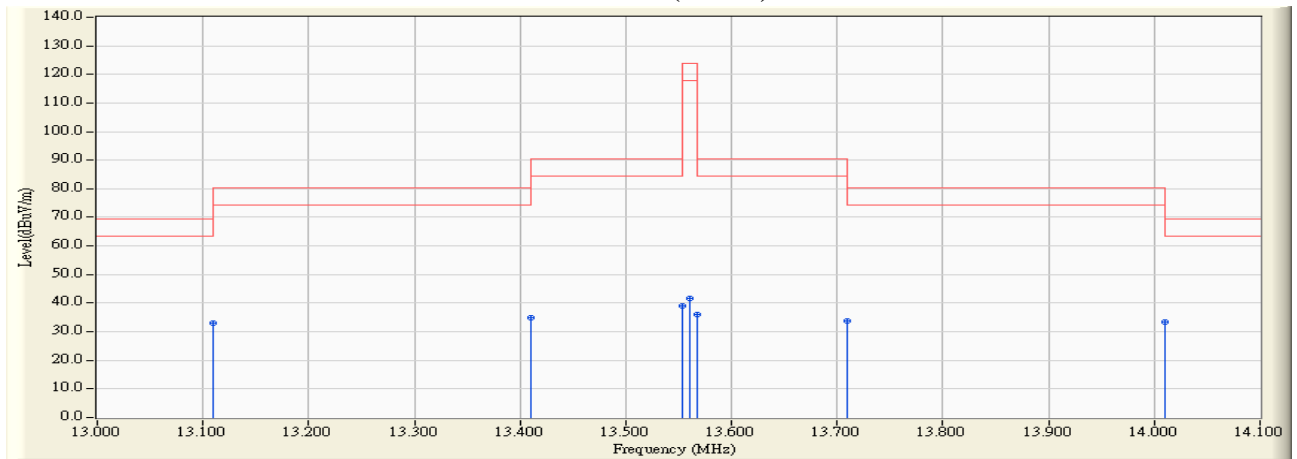

Vertical (X-axis)

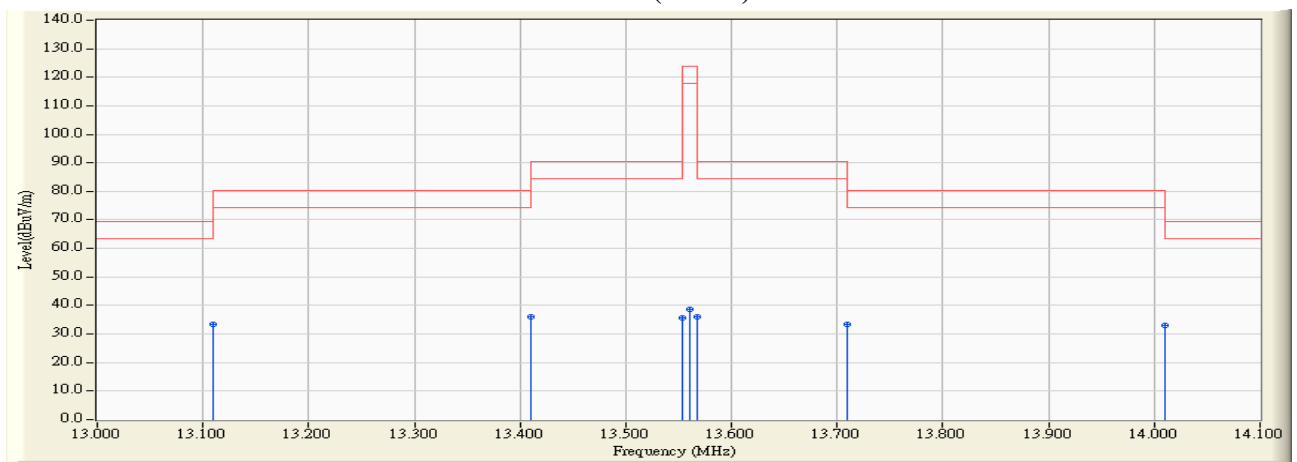

Product : Mobile Tablet
 Test Item : Fundamental Radiated Emission
 Test Site : No.3 OATS
 Test date : 2017/02/06
 Test Mode : Mode 1: Transmit- Y-axis

Frequency MHz	Correct Factor dB	Reading Level dBuV	Measurement Level dBuV/m	Margin dB	Limit dBuV/m
Y-axis					
Quasi-Peak					
Horizontal					
13.110	20.020	15.140	35.160	-34.340	69.500
13.410	20.020	13.535	33.555	-46.945	80.500
13.553	20.020	22.025	42.045	-48.455	90.500
13.560	20.020	25.642	45.662	-78.338	124.000
13.567	20.020	22.478	42.498	-48.002	90.500
13.710	20.020	12.993	33.013	-47.487	80.500
14.010	20.020	13.431	33.451	-36.049	69.500
Vertical					
13.110	20.020	13.268	33.288	-36.212	69.500
13.410	20.020	13.269	33.289	-47.211	80.500
13.553	20.020	22.800	42.820	-47.680	90.500
13.560	20.020	26.748	46.768	-77.232	124.000
13.567	20.020	22.353	42.373	-48.127	90.500
13.710	20.020	13.035	33.055	-47.445	80.500
14.010	20.020	13.141	33.161	-36.339	69.500

Note:

1. Limit=84dBuV/m + 40*Log (30(m)/3(m))=124dBuV/m
2. All Readings below 1GHz are Quasi-Peak, above are average value.
3. Measurement Level = Reading Level + Correct Factor.
4. The average measurement was not performed when the peak measured data under the limit of average detection. If the readings given are average, peak measurement should also be supplied.

Horizontal (Y-axis)

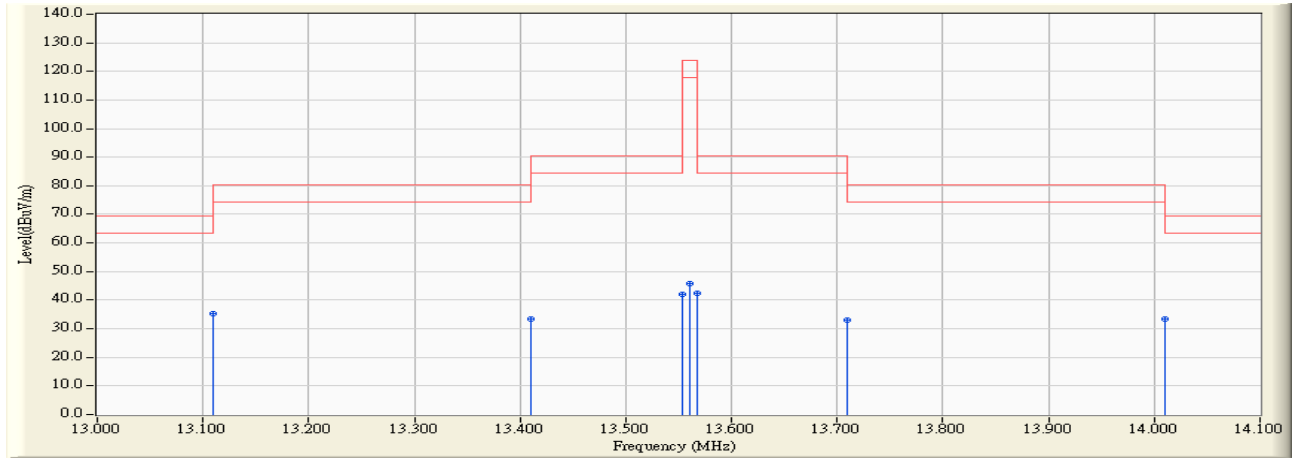

Vertical (Y-axis)

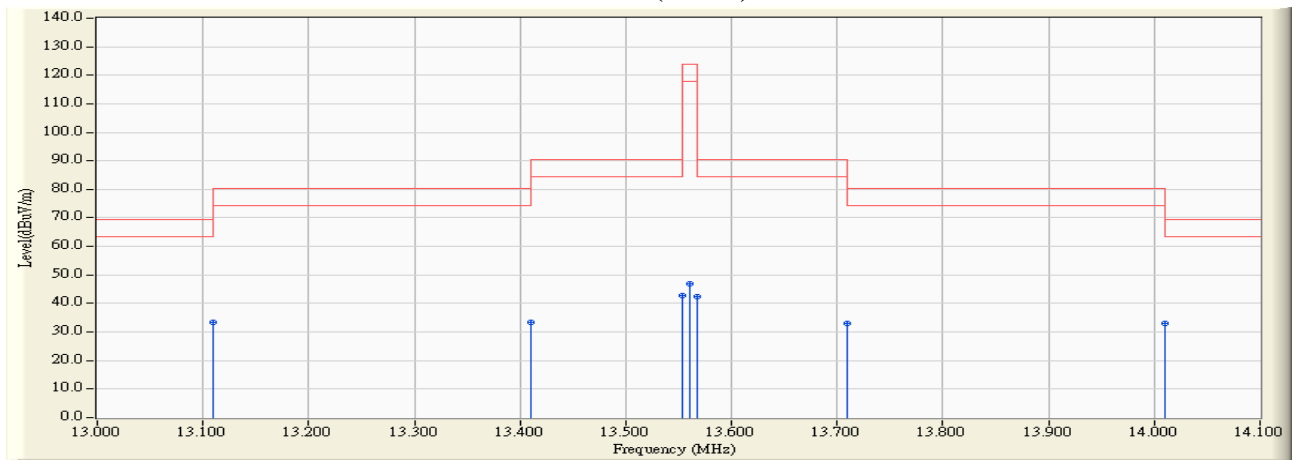

Product : Mobile Tablet
 Test Item : Fundamental Radiated Emission
 Test Site : No.3 OATS
 Test date : 2017/02/06
 Test Mode : Mode 1: Transmit- Z-axis

Frequency MHz	Correct Factor dB	Reading Level dBuV	Measurement Level dBuV/m	Margin dB	Limit dBuV/m
Z-axis					
Quasi-Peak					
Horizontal					
13.110	20.020	14.019	34.039	-35.461	69.500
13.410	20.020	14.012	34.032	-46.468	80.500
13.553	20.020	21.645	41.665	-48.835	90.500
13.560	20.020	25.410	45.430	-78.570	124.000
13.567	20.020	22.048	42.068	-48.432	90.500
13.710	20.020	13.057	33.077	-47.423	80.500
14.010	20.020	13.485	33.505	-35.995	69.500
Vertical					
13.110	20.020	13.848	33.868	-35.632	69.500
13.410	20.020	13.362	33.382	-47.118	80.500
13.553	20.020	23.690	43.710	-46.790	90.500
13.560	20.020	27.438	47.458	-76.542	124.000
13.567	20.020	23.023	43.043	-47.457	90.500
13.710	20.020	13.408	33.428	-47.072	80.500
14.010	20.020	12.972	32.992	-36.508	69.500

Note:

1. Limit=84dBuV/m + 40*Log (30(m)/3(m))=124dBuV/m
2. All Readings below 1GHz are Quasi-Peak, above are average value.
3. Measurement Level = Reading Level + Correct Factor.
4. The average measurement was not performed when the peak measured data under the limit of average detection. If the readings given are average, peak measurement should also be supplied.

Horizontal (Z-axis)

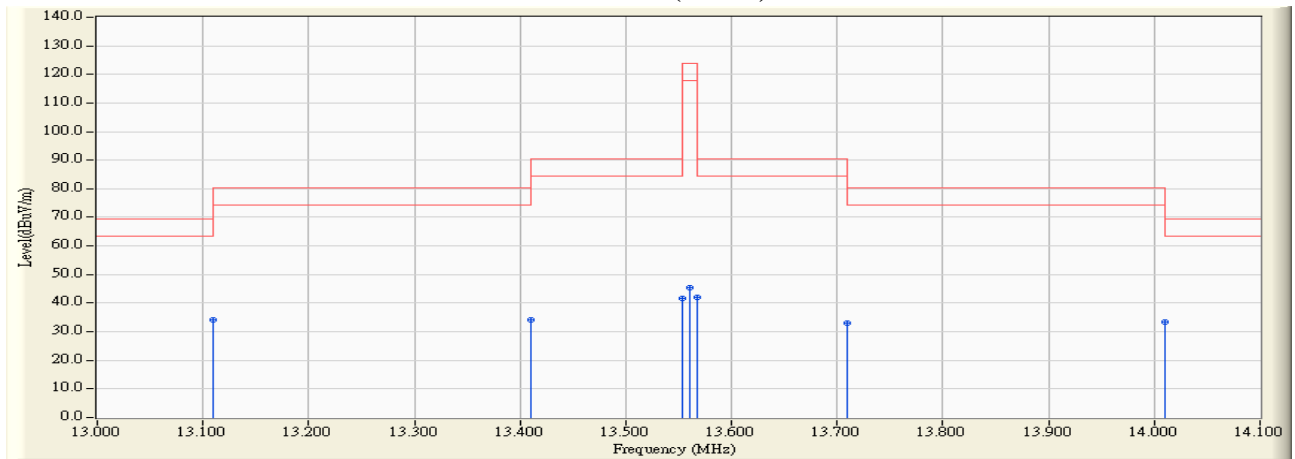

Vertical (Z-axis)

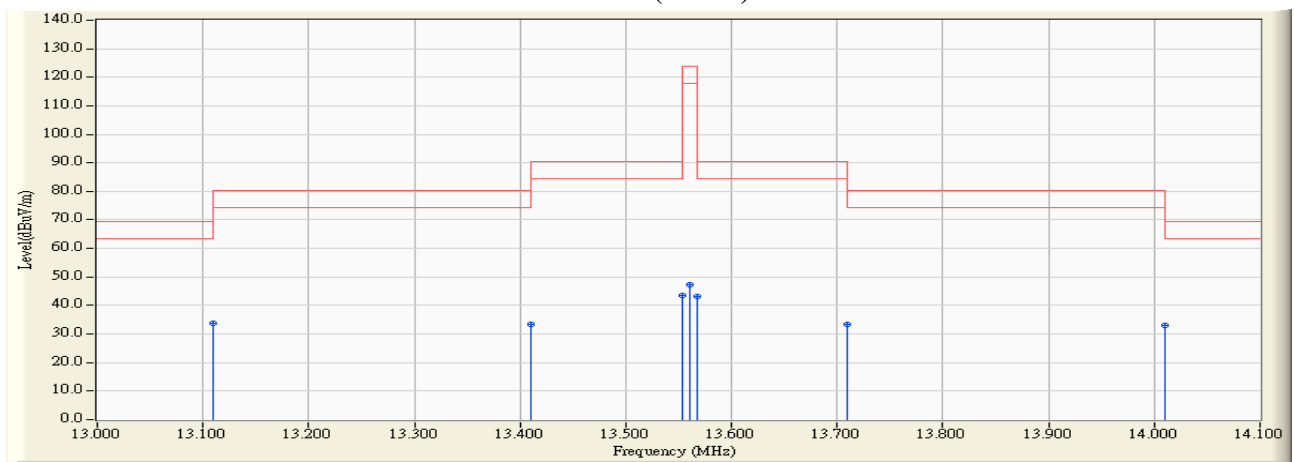

Product : Mobile Tablet
 Test Item : General Radiated Emission Data (below 30MHz)
 Test Site : No.3 OATS
 Test date : 2017/02/06
 Test Mode : Mode 1: Transmit

Frequency	Correct	Reading	Measurement	Margin	Limit
MHz	Factor	Level	Level	dB	dBuV/m
	dB	dBuV	dBuV/m		
Horizontal					
27.120	20.200	13.639	33.839	-35.701	69.540
Vertical					
27.120	20.200	15.200	35.400	-34.140	69.540

Note:

1. Limit=29.54dBuV/m + 40*Log (30(m)/3(m))=69.54dBuV/m
2. All Readings below 1GHz are Quasi-Peak, above are average value.
3. " " means the worst emission level.
4. Measurement Level = Reading Level + Correct Factor.

Product : Mobile Tablet
 Test Item : General Radiated Emission Data (above 30MHz)
 Test Site : No.3 OATS
 Test date : 2017/02/06
 Test Mode : Mode 1: Transmit

Frequency MHz	Correct Factor dB	Reading Level dBuV	Measurement Level dBuV/m	Margin dB	Limit dBuV/m
Horizontal					
QP Detector					
130.880	-7.407	40.331	32.923	-10.577	43.500
371.440	0.860	41.192	42.052	-3.948	46.000
460.680	4.030	35.062	39.092	-6.908	46.000
689.600	3.642	33.376	37.018	-8.982	46.000
831.220	7.121	31.028	38.149	-7.851	46.000
961.200	6.810	42.448	49.258	-4.742	54.000
Vertical					
QP Detector					
99.840	-6.063	37.698	31.635	-11.865	43.500
148.340	-5.406	40.384	34.978	-8.522	43.500
371.440	-0.310	34.960	34.650	-11.350	46.000
687.660	2.292	34.303	36.595	-9.405	46.000
833.160	1.716	31.702	33.418	-12.582	46.000
961.200	3.310	43.806	47.116	-6.884	54.000

Note:

1. All Readings below 1GHz are Quasi-Peak, above are average value.
2. "█" means the worst emission level.
3. Measurement Level = Reading Level + Correct Factor

4. Band Edge

4.1. Test Setup

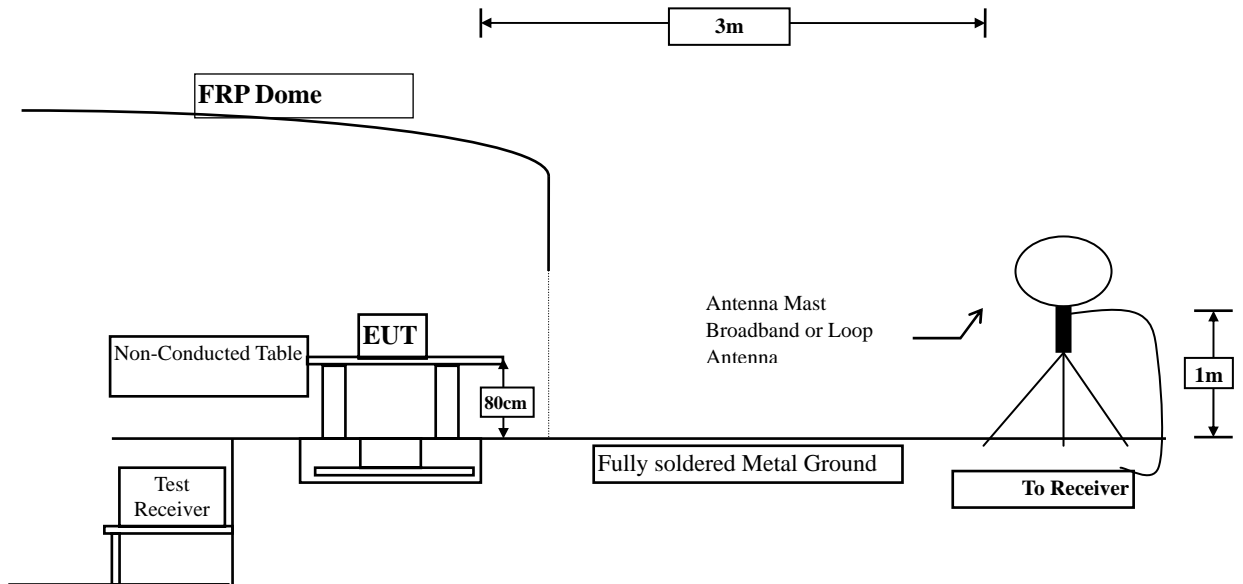

4.2. Limits

In any 9 kHz bandwidth outside the frequency band in which the spread spectrum intentional radiator is operating, the radio frequency power that is produced by the intentional radiator shall be at least 50 dB below that in the 9 kHz bandwidth within the band that contains the highest level of the desired power, based on either an RF conducted or a radiated measurement. Attenuation below the general limits specified in Section 15.209(a) is not required. In addition, radiated emissions which fall in the restricted bands, as defined in Section 15.205(a), must also comply with the radiated emission limits specified in Section 15.209(a) (see Section 15.205(c)).

4.3. Test Procedure

The EUT and its simulators are placed on a turn table which is 0.8 meter above ground. The turn table can rotate 360 degrees to determine the position of the maximum emission level. The EUT was positioned such that the distance from antenna to the EUT was 3 meters.

The antenna can move up and down between 1 meter and 4 meters to find out the maximum emission level.

Both horizontal and vertical polarization of the antenna are set on measurement. In order to find the maximum emission, all of the interface cables must be manipulated according to ANSI C63.10: 2013 on radiated measurement.

The bandwidth below 30MHz setting on the field strength meter is 9kHz and above 30MHz is 120kHz.

4.4. Uncertainty

± 4.08 dB above 1GHz

± 4.22 dB below 1GHz

4.5. Test Result of Band Edge

Product : Mobile Tablet
 Test Item : Band Edge Data
 Test Site : No.3 OATS
 Test date : 2017/02/06
 Test Mode : Mode 1: Transmit

RF Radiated Measurement

(Horizontal)

Frequency (MHz)	Correct Factor (dB)	Reading Level (dBuV)	Emission Level (dBuV/m)	QP Limit (dBuV/m)	Result
13.110	20.020	14.019	34.039	69.540	Pass
13.360	20.020	13.082	33.102	69.540	Pass
13.410	20.020	14.012	34.032	69.540	Pass
14.010	20.020	13.485	33.505	69.540	Pass

Note:

1. All Readings below 1GHz are Quasi-Peak, above are average value.
2. “█” means the worst emission level.
3. Measurement Level = Reading Level + Correct Factor

(Vertical)

Frequency (MHz)	Correct Factor (dB)	Reading Level (dBuV)	Emission Level (dBuV/m)	QP Limit (dBuV/m)	Result
13.110	20.020	13.848	33.868	69.540	Pass
13.360	20.020	12.856	32.876	69.540	Pass
13.410	20.020	13.362	33.382	69.540	Pass
14.010	20.020	12.972	32.992	69.540	Pass

Note:

1. All Readings below 1GHz are Quasi-Peak, above are average value.
2. “█” means the worst emission level.
3. Measurement Level = Reading Level + Correct Factor

5. Frequency Tolerance

5.1. Test Setup

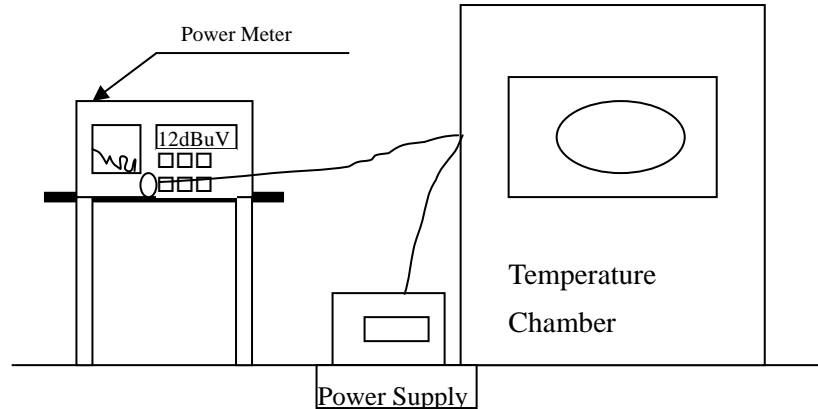

5.2. Limits

The frequency tolerance of the carrier signal shall be maintained within $\pm 0.01\%$ of the operating frequency.

5.3. Test Procedure

The over operating frequency over a temperature variation of -20 degrees to +50 degrees C at normal supply voltage, and for a variation in the primary supply voltage from 85% to 115% of the rated supply voltage at a temperature of 20 degrees C. For battery operated equipment, the equipment tests shall be performed using a new battery.

5.4. Uncertainty

± 283 Hz

5.5. Test Result of Frequency Stability

Product : Mobile Tablet
 Test Item : Frequency Tolerance
 Test Site : Temperature Chamber
 Test date : 2017/02/06
 Test Mode : Mode 1: Transmit

Temperature (°C)	Voltage (V)	Observe Time	Declared Frequency (MHz)	Read Frequency (MHz)	Tolerance (%)	Limit (%)
20	120	start	13.56	13.55980	-0.001475	± 0.01 %
		2mins	13.56	13.55980	-0.001475	
		5mins	13.56	13.55980	-0.001475	
		10mins	13.56	13.55980	-0.001475	
20	138	start	13.56	13.55980	-0.001475	± 0.01 %
		2mins	13.56	13.55980	-0.001475	
		5mins	13.56	13.55980	-0.001475	
		10mins	13.56	13.55980	-0.001475	
20	102	start	13.56	13.55980	-0.001475	± 0.01 %
		2mins	13.56	13.55980	-0.001475	
		5mins	13.56	13.55980	-0.001475	
		10mins	13.56	13.55980	-0.001475	
50	120	start	13.56	13.55974	-0.001917	± 0.01 %
		2mins	13.56	13.55974	-0.001917	
		5mins	13.56	13.55974	-0.001917	
		10mins	13.56	13.55974	-0.001917	
40	120	start	13.56	13.55981	-0.001401	± 0.01 %
		2mins	13.56	13.55981	-0.001401	
		5mins	13.56	13.55981	-0.001401	
		10mins	13.56	13.55981	-0.001401	
30	120	start	13.56	13.55985	-0.001106	± 0.01 %
		2mins	13.56	13.55985	-0.001106	
		5mins	13.56	13.55985	-0.001106	
		10mins	13.56	13.55985	-0.001106	

10	120	start	13.56	13.55972	-0.002065	± 0.01 %
		2mins	13.56	13.55972	-0.002065	
		5mins	13.56	13.55972	-0.002065	
		10mins	13.56	13.55972	-0.002065	
0	120	start	13.56	13.55969	-0.002286	± 0.01 %
		2mins	13.56	13.55969	-0.002286	
		5mins	13.56	13.55969	-0.002286	
		10mins	13.56	13.55969	-0.002286	
-10	120	start	13.56	13.55941	-0.004351	± 0.01 %
		2mins	13.56	13.55941	-0.004351	
		5mins	13.56	13.55941	-0.004351	
		10mins	13.56	13.55941	-0.004351	
-20	120	start	13.56	13.55938	-0.004572	± 0.01 %
		2mins	13.56	13.55938	-0.004572	
		5mins	13.56	13.55938	-0.004572	
		10mins	13.56	13.55938	-0.004572	

6. EMI Reduction Method During Compliance Testing

No modification was made during testing.

Attachment 1: EUT Test Photographs

Attachment 2: EUT Detailed Photographs