

FCC Test Report

Product Name	Medical Cart Computer
Model No.	DT590B, DT592B, DT594B
FCC ID.	YE3800G

Applicant	DT Research, Inc.
Address	6F, No. 1, NingPo E. St. Taipei, 100 Taiwan

Date of Receipt	Jan. 18, 2016
Issued Date	Mar. 04, 2016
Report No.	1610298R-RFUSP01V00-A
Report Version	V1.0



The test results relate only to the samples tested.

The test results shown in the test report are traceable to the national/international standard through the calibration report of the equipment and evaluated measurement uncertainty herein.

This report must not be used to claim product endorsement by TAF or any agency of the government.

The test report shall not be reproduced without the written approval of QuieTek Corporation.

Test Report

Issued Date: Mar. 04, 2016

Report No.: 1610298R-RFUSP01V00-A



Product Name	Medical Cart Computer
Applicant	DT Research, Inc.
Address	6F, No. 1, NingPo E. St. Taipei, 100 Taiwan
Manufacturer	DT Research, Inc.
Model No.	DT590B, DT592B, DT594B
FCC ID.	YE3800G
EUT Rated Voltage	AC 100-240V, 50-60Hz
EUT Test Voltage	AC 120V/60Hz
Trade Name	DT Research, Inc.
Applicable Standard	FCC CFR Title 47 Part 15 Subpart C: 2014 ANSI C63.4: 2014, ANSI C63.10: 2013 KDB 558074 D01 DTS Meas Guidance v03r04
Test Result	Complied

Documented By : Jinn Chen
(Senior Adm. Specialist / Jinn Chen)

Tested By : Yulin Chen
(Assistant Engineer / Yulin Chen)

Approved By : 
(Director / Vincent Lin)

TABLE OF CONTENTS

Description	Page
1. GENERAL INFORMATION	4
1.1. EUT Description.....	4
1.2. Operational Description.....	6
1.3. Tested System Details.....	7
1.4. Configuration of Tested System	8
1.5. EUT Exercise Software	9
1.6. Test Facility	10
2. CONDUCTED EMISSION	11
2.1. Test Equipment	11
2.2. Test Setup	11
2.3. Limits.....	12
2.4. Test Procedure	12
2.5. Uncertainty	12
2.6. Test Result of Conducted Emission.....	13
3. PEAK POWER OUTPUT	17
3.1. Test Equipment	17
3.2. Test Setup	17
3.3. Limit	17
3.4. Test Procedure	17
3.5. Uncertainty	17
3.6. Test Result of Peak Power Output	18
4. RADIATED EMISSION	19
4.1. Test Equipment	19
4.2. Test Setup	19
4.3. Limits.....	20
4.4. Test Procedure	21
4.5. Uncertainty	21
4.6. Test Result of Radiated Emission.....	22
5. RF ANTENNA CONDUCTED TEST	30
5.1. Test Equipment	30
5.2. Test Setup	30
5.3. Limits.....	30
5.4. Test Procedure	30
5.5. Uncertainty	30
5.6. Test Result of RF Antenna Conducted Test	31
6. BAND EDGE	34
6.1. Test Equipment	34
6.2. Test Setup	35
6.3. Limit	36
6.4. Test Procedure	36
6.5. Uncertainty	36
6.6. Test Result of Band Edge	37
7. OCCUPIED BANDWIDTH (6DB BW).....	45
7.1. Test Equipment	45
7.2. Test Setup	45
7.3. Limits.....	45
7.4. Test Procedure	45
7.5. Uncertainty	45
7.6. Test Result of Occupied Bandwidth	46
8. POWER DENSITY	49
8.1. Test Equipment	49
8.2. Test Setup	49
8.3. Limits.....	49
8.4. Test Procedure	49
8.5. Uncertainty	49
8.6. Test Result of Power Density	50
9. EMI REDUCTION METHOD DURING COMPLIANCE TESTING	53
Attachment 1: EUT Test Photographs	
Attachment 2: EUT Detailed Photographs	

1. GENERAL INFORMATION

1.1. EUT Description

Product Name	Medical Cart Computer
Trade Name	DT Research, Inc.
Model No.	DT590B, DT592B, DT594B
FCC ID.	YE3800G
Frequency Range	2402 – 2480MHz
Channel Number	V4.0: 40CH
Type of Modulation	V4.0: GFSK(1Mbps)
Antenna Type	PIFA Antenna
Channel Control	Auto
Antenna Gain	Refer to the table “Antenna List”
Power Cable	Non-shielded, 1.8m
Power Adapter	MFR: EDAC, M/N: EM11201D Input: 100-240Vac, 2.0-1.0A, 50-60Hz Output: 18-24V $\overline{\text{---}}$ 120W max Cable Out: Non-shielded, 1.2m, with one ferrite core bonded.

Antenna List

No.	Manufacturer	Part No.	Antenna Type	Peak Gain
1	CUELE	27-594-720020 (210-80012) (Main) 27-594-720010 (210-80013) (Aux)	PIFA Antenna	1.51dBi for 2.4 GHz

Note:

1. The antenna of EUT is conforming to FCC 15.203.

Center Frequency of Each Channel: (For V4.0)

Channel	Frequency	Channel	Frequency	Channel	Frequency	Channel	Frequency
Channel 00:	2402 MHz	Channel 01:	2404 MHz	Channel 02:	2406 MHz	Channel 03:	2408 MHz
Channel 04:	2410 MHz	Channel 05:	2412 MHz	Channel 06:	2414 MHz	Channel 07:	2416 MHz
Channel 08:	2418 MHz	Channel 09:	2420 MHz	Channel 10:	2422 MHz	Channel 11:	2424 MHz
Channel 12:	2426 MHz	Channel 13:	2428 MHz	Channel 14:	2430 MHz	Channel 15:	2432 MHz
Channel 16:	2434 MHz	Channel 17:	2436 MHz	Channel 18:	2438 MHz	Channel 19:	2440 MHz
Channel 20:	2442 MHz	Channel 21:	2444 MHz	Channel 22:	2446 MHz	Channel 23:	2448 MHz
Channel 24:	2450 MHz	Channel 25:	2452 MHz	Channel 26:	2454 MHz	Channel 27:	2456 MHz
Channel 28:	2458 MHz	Channel 29:	2460 MHz	Channel 30:	2462 MHz	Channel 31:	2464 MHz
Channel 32:	2466 MHz	Channel 33:	2468 MHz	Channel 34:	2470 MHz	Channel 35:	2472 MHz
Channel 36:	2474 MHz	Channel 37:	2476 MHz	Channel 38:	2478 MHz	Channel 39:	2480 MHz

Note:

1. The EUT is a Medical Cart Computer with a built-in 2.4GHz and 5GHz WLAN 、Bluetooth transceiver, this report for Bluetooth V4.0.
2. These tests were conducted on a sample for the purpose of demonstrating compliance of Bluetooth transmitter with Part 15 Subpart C Paragraph 15.247 for spread spectrum devices.
3. Regarding to the operation frequency, the lowest, middle and highest frequency are selected to perform the test.
4. Medical Cart Computer operation on 19-inch 、22-inch and 24-inch size,it was evaluated at both 22-inch and 24-inch size . 22-inch was found through pre-testing, 22-inch produce emissions was worse case.

Test Mode	Mode 1: Transmit - BLE (GFSK)
-----------	-------------------------------

1.3. Tested System Details

The types for all equipment, plus descriptions of all cables used in the tested system (including inserted cards) are:

For 19”:

	Product	Manufacturer	Model No.	Serial No.	Power Cord
1	LCD Monitor	DELL	ST2320Lf	CN-0M2nn6-72872-22I-C A1S	Non-Shielded, 1.8m
2	LCD Monitor	ASUS	VS229HA	F4LMQS135395	Non-Shielded, 1.8m
3	Modem	ACEEX	DM-1414	0102027541	Non-Shielded, 1.8m
4	Keyboard	Logitech	Y-U0009	LZ027HU	N/A
5	USB Mouse	Logitech	M-U0026	1245HS0684H8	N/A
6	iPod nano	Apple	A1199	5U728909VQ5	N/A
7	iPod nano	Apple	A1199	YM73337PVQ5	N/A
8	iPod nano	Apple	A1199	YM73336EVQ5	N/A
9	iPod nano	Apple	A1199	YM7333DCVQ5	N/A
10	Microphone & Earphone	Ergotech	ET-E201	N/A	N/A

For 22”:

	Product	Manufacturer	Model No.	Serial No.	Power Cord
1	LCD Monitor	DELL	ST2320Lf	CN-0M2nn6-72872-22I-C A1S	Non-Shielded, 1.8m
2	LCD Monitor	ASUS	VS229HA	F4LMQS135395	Non-Shielded, 1.8m
3	Modem	ACEEX	DM-1414	0102027541	Non-Shielded, 1.8m
4	Modem	ACEEX	DM-1414	0102027559	Non-Shielded, 1.8m
5	Modem	ACEEX	DM-1414	0102027533	Non-Shielded, 1.8m
6	Modem	ACEEX	DM-1414	0102027537	Non-Shielded, 1.8m
7	Keyboard	Logitech	Y-U0009	LZ027HU	N/A
8	USB Mouse	Logitech	M-U0026	1245HS0684H8	N/A
9	iPod nano	Apple	A1199	5U728909VQ5	N/A
10	iPod nano	Apple	A1199	YM73337PVQ5	N/A
11	iPod nano	Apple	A1199	YM73336EVQ5	N/A
12	iPod nano	Apple	A1199	YM7333DCVQ5	N/A
13	Microphone & Earphone	Ergotech	ET-E201	N/A	N/A

For 19”:

	Signal Cable Type	Signal cable Description
A	HDMI Card	Non-Shielded, 1.8m, two PCS.
B	Modem Card	Shielded, 1.5m
C	Keyboard Cable	Shielded, 1.8m
D	Mouse Cable	Shielded, 1.8m
E	USB Cable	Shielded, 1.2m, four PCS.
F	Earphone Cable	Non-Shielded, 2m

For 22”:

Signal Cable Type	Signal cable Description
A	HDMI Card
B	Modem Card
C	Keyboard Cable
D	Mouse Cable
E	USB Cable
F	Earphone Cable

1.4. Configuration of Tested System

For 19”:

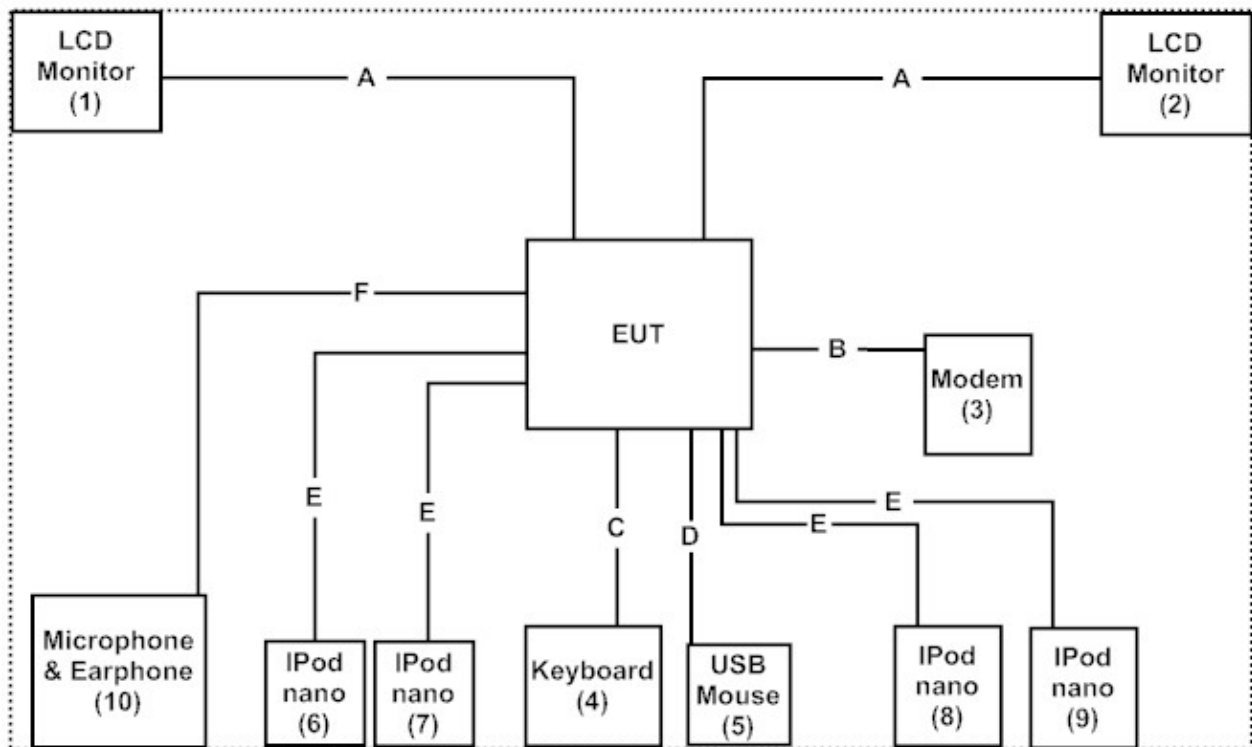

For 22”:

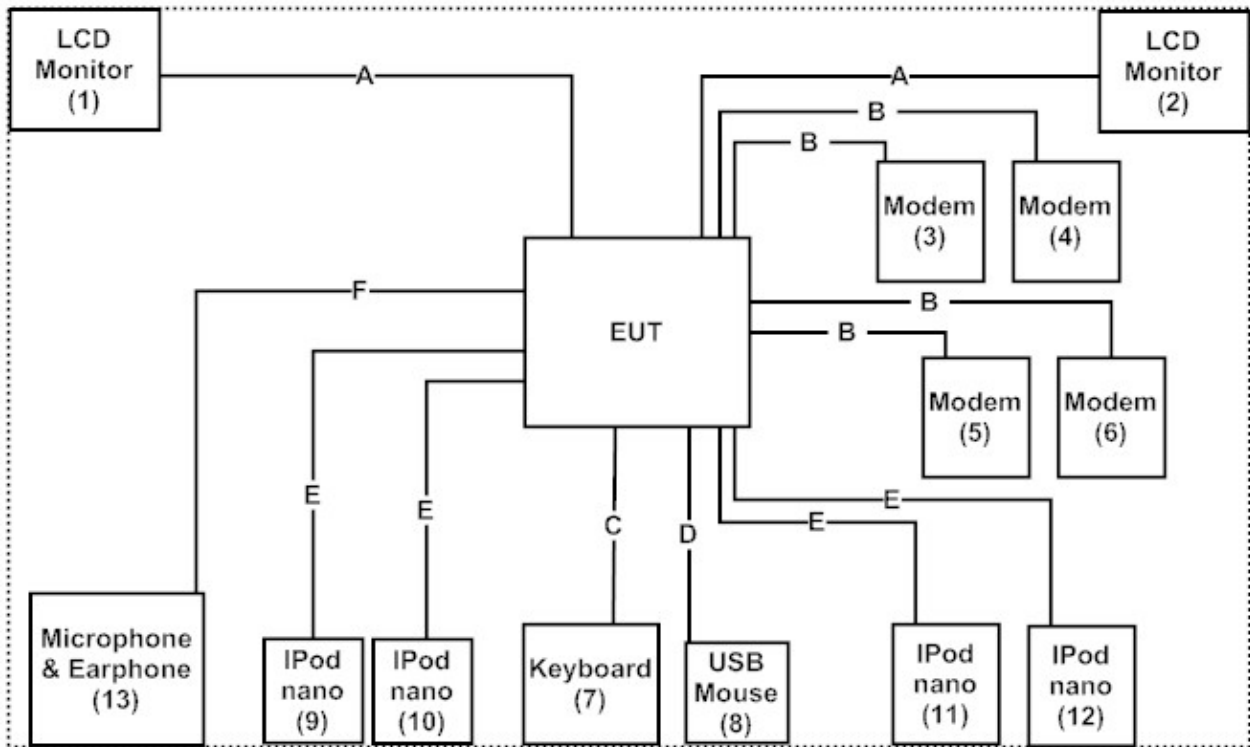

1.5. EUT Exercise Software

- (1) Setup the EUT as shown in Section 1.4.
- (2) Execute software “DRTU-V1.7.4-1041” on the EUT
- (3) Configure the test mode, the test channel, and the data rate.
- (4) Press “OK” to start the continuous Transmit.
- (5) Verify that the EUT works properly.

1.6. Test Facility

Ambient conditions in the laboratory:

Items	Required (IEC 68-1)	Actual
Temperature (°C)	15-35	20-35
Humidity (%RH)	25-75	30-65
Barometric pressure (mbar)	860-1060	950-1000

The related certificate for our laboratories about the test site and management system can be downloaded from

Quietek Corporation's Web Site: <http://www.quietek.com/chinese/about/certificates.aspx?bval=5>

The address and introduction of Quietek Corporation's laboratories can be founded in our Web site:
<http://www.quietek.com/>

Site Description: File on
 Federal Communications Commission
 FCC Engineering Laboratory
 7435 Oakland Mills Road
 Columbia, MD 21046
 Registration Number: 92195

Site Name: Quietek Corporation
 Site Address: No.5-22, Ruishukeng,
 Linkou Dist. New Taipei City 24451,
 Taiwan, R.O.C.
 TEL: 886-2-8601-3788 / FAX : 886-2-8601-3789
 E-Mail : service@quietek.com

FCC Accreditation Number: TW1014

2. Conducted Emission

2.1. Test Equipment

	Equipment	Manufacturer	Model No. / Serial No.	Last Cal.	Remark
X	Test Receiver	R & S	ESCS 30 / 825442/018	Sep., 2015	
X	Artificial Mains Network	R & S	ENV4200 / 848411/10	Feb., 2016	Peripherals
X	LISN	R & S	ESH3-Z5 / 825562/002	Feb., 2016	EUT
	DC LISN	Schwarzbeck	8226 / 176	Mar, 2016	EUT
X	Pulse Limiter	R & S	ESH3-Z2 / 357.8810.52	Feb., 2016	
	No.1 Shielded Room				

Note:

1. All equipments are calibrated every one year.
2. The test instruments marked by “X” are used to measure the final test results.

2.2. Test Setup

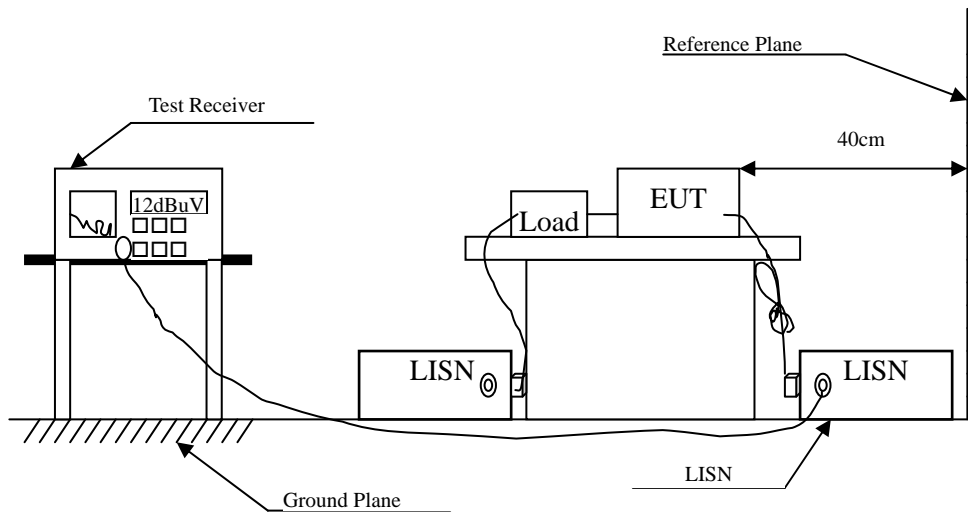

2.3. Limits

FCC Part 15 Subpart C Paragraph 15.207 (dBuV) Limit		
Frequency MHz	Limits	
	QP	AV
0.15 - 0.50	66-56	56-46
0.50-5.0	56	46
5.0 - 30	60	50

Remarks: In the above table, the tighter limit applies at the band edges.

2.4. Test Procedure

The EUT and Peripherals are connected to the main power through a line impedance stabilization network (L.I.S.N.). This provides a 50 ohm /50uH coupling impedance for the measuring equipment. The peripheral devices are also connected to the main power through a LISN that provides a 50ohm /50uH coupling impedance with 50ohm termination. (Please refer to the block diagram of the test setup and photographs.)

Both sides of A.C. line are checked for maximum conducted interference. In order to find the maximum emission, the relative positions of equipment and all the interface cables must be changed according to ANSI C63.4: 2014 on conducted measurement.

Conducted emissions were investigated over the frequency range from 0.15MHz to 30MHz using a receiver bandwidth of 9kHz.

The EUT was setup to ANSI C63.4, 2014; tested to DTS test procedure of FCC KDB-558074 for compliance to FCC 47CFR Subpart C requirements.

2.5. Uncertainty

± 2.26 dB

2.6. Test Result of Conducted Emission

Product : Medical Cart Computer
Test Item : Conducted Emission Test
Power Line : Line 1
Test Mode : Mode 1: Transmit - BLE (GFSK) (2442MHz) (19'')

Frequency MHz	Correct Factor dB	Reading Level dBuV	Measurement Level dBuV	Margin dB	Limit dBuV
LINE 1					
Quasi-Peak					
0.154	9.783	17.620	27.403	-38.483	65.886
0.576	9.794	20.120	29.914	-26.086	56.000
0.638	9.799	17.460	27.259	-28.741	56.000
15.326	10.159	17.910	28.069	-31.931	60.000
18.787	10.185	15.200	25.385	-34.615	60.000
23.998	10.198	14.040	24.238	-35.762	60.000
Average					
0.154	9.783	13.380	23.163	-32.723	55.886
0.576	9.794	16.880	26.674	-19.326	46.000
0.638	9.799	7.650	17.449	-28.551	46.000
15.326	10.159	12.510	22.669	-27.331	50.000
18.787	10.185	11.940	22.125	-27.875	50.000
23.998	10.198	10.130	20.328	-29.672	50.000

Note:

1. All Reading Levels are Quasi-Peak and average value.
2. "■" means the worst emission level.
3. Measurement Level = Reading Level + Correct Factor

Product : Medical Cart Computer
 Test Item : Conducted Emission Test
 Power Line : Line 2
 Test Mode : Mode 1: Transmit - BLE (GFSK) (2442MHz) (19'')

Frequency MHz	Correct Factor dB	Reading Level dBuV	Measurement Level dBuV	Margin dB	Limit dBuV
LINE 2					
Quasi-Peak					
0.173	9.833	14.160	23.993	-41.350	65.343
0.209	9.835	12.560	22.395	-41.919	64.314
0.384	9.849	7.820	17.669	-41.645	59.314
0.513	9.859	15.190	25.049	-30.951	56.000
14.029	10.271	17.420	27.691	-32.309	60.000
23.982	10.398	16.300	26.698	-33.302	60.000
Average					
0.173	9.833	11.670	21.503	-33.840	55.343
0.209	9.835	8.500	18.335	-35.979	54.314
0.384	9.849	1.690	11.539	-37.775	49.314
0.513	9.859	13.520	23.379	-22.621	46.000
14.029	10.271	13.380	23.651	-26.349	50.000
23.982	10.398	14.530	24.928	-25.072	50.000

Note:

1. All Reading Levels are Quasi-Peak and average value.
2. "■" means the worst emission level.
3. Measurement Level = Reading Level + Correct Factor

Product : Medical Cart Computer
Test Item : Conducted Emission Test
Power Line : Line 1
Test Mode : Mode 1: Transmit - BLE (GFSK) (2442MHz) (22'')

Frequency MHz	Correct Factor dB	Reading Level dBuV	Measurement Level dBuV	Margin dB	Limit dBuV
LINE 1					
Quasi-Peak					
0.177	9.777	39.210	48.987	-16.242	65.229
0.220	9.776	37.560	47.336	-16.664	64.000
0.338	9.775	25.200	34.975	-25.654	60.629
7.130	10.045	9.300	19.345	-40.655	60.000
10.482	10.095	14.370	24.465	-35.535	60.000
14.310	10.145	33.080	43.225	-16.775	60.000
Average					
0.177	9.777	22.560	32.337	-22.892	55.229
0.220	9.776	22.460	32.236	-21.764	54.000
0.338	9.775	15.450	25.225	-25.404	50.629
7.130	10.045	4.790	14.835	-35.165	50.000
10.482	10.095	8.070	18.165	-31.835	50.000
14.310	10.145	28.310	38.455	-11.545	50.000

Note:

1. All Reading Levels are Quasi-Peak and average value.
2. "■" means the worst emission level.
3. Measurement Level = Reading Level + Correct Factor

Product : Medical Cart Computer
 Test Item : Conducted Emission Test
 Power Line : Line 2
 Test Mode : Mode 1: Transmit - BLE (GFSK) (2442MHz) (22'')

Frequency MHz	Correct Factor dB	Reading Level dBuV	Measurement Level dBuV	Margin dB	Limit dBuV
LINE 2					
Quasi-Peak					
0.162	9.832	43.900	53.732	-11.925	65.657
0.189	9.834	36.350	46.184	-18.702	64.886
0.236	9.838	24.550	34.388	-29.155	63.543
0.334	9.845	18.120	27.965	-32.778	60.743
3.845	10.050	7.090	17.140	-38.860	56.000
14.302	10.275	32.570	42.845	-17.155	60.000
Average					
0.162	9.832	23.590	33.422	-22.235	55.657
0.189	9.834	29.640	39.474	-15.412	54.886
0.236	9.838	13.220	23.058	-30.485	53.543
0.334	9.845	12.700	22.545	-28.198	50.743
3.845	10.050	0.440	10.490	-35.510	46.000
14.302	10.275	27.790	38.065	-11.935	50.000

Note:

1. All Reading Levels are Quasi-Peak and average value.
2. "■" means the worst emission level.
3. Measurement Level = Reading Level + Correct Factor

3. Peak Power Output

3.1. Test Equipment

	Equipment	Manufacturer	Model No./Serial No.	Last Cal.
X	Power Meter	Anritsu	ML2495A/6K00003357	May, 2015
X	Power Sensor	Anritsu	MA2411B/0738448	Jun, 2015

Note: 1. All equipments are calibrated every one year.
 2. The test instruments marked by “X” are used to measure the final test results.

3.2. Test Setup

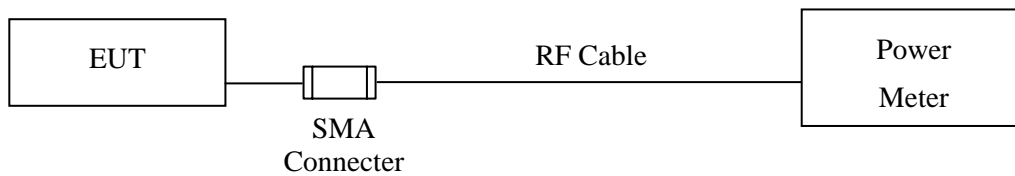

3.3. Limit

The maximum peak power shall be less 1Watt.

3.4. Test Procedure

Tested according to DTS test procedure of KDB 558074 for compliance to FCC 47CFR 15.247 requirements. The maximum peak conducted output power using KDB 558074 section 9.1.3 PKPM1 Peak power meter method.

3.5. Uncertainty

± 1.27 dB

3.6. Test Result of Peak Power Output

Product : Medical Cart Computer
 Test Item : Peak Power Output
 Test Site : No.3 OATS
 Test Mode : Mode 1: Transmit - BLE (GFSK) (19''+22''+24'')

Channel No.	Frequency (MHz)	Measurement (dBm)	Required Limit	Result
Channel 00	2402.00	0.37	1 Watt= 30 dBm	Pass
Channel 19	2440.00	1.26	1 Watt= 30 dBm	Pass
Channel 39	2480.00	1.57	1 Watt= 30 dBm	Pass

4. Radiated Emission

4.1. Test Equipment

The following test equipments are used during the radiated emission test:

Test Site	Equipment	Manufacturer	Model No./Serial No.	Last Cal.	
☒ Site # 3	X	Magnetic Loop Antenna	Teseq	HLA6121/ 37133	Sep, 2015
	X	Bilog Antenna	Schaffner Chase	CBL6112B/ 2707	Jun, 2015
	X	EMI Test Receiver	R&S	ESCS 30/838251/ 001	Jun, 2015
	X	Coaxial Cable	QTK(Arnist)	RG 214/ LC003-RG	Jun, 2015
	X	Coaxial signal switch	Arnist	MP59B/ 6200798682	Jun, 2015

Test Site	Equipment	Manufacturer	Model No./Serial No.	Last Cal.	
☒ CB # 8	X	Spectrum Analyzer	R&S	FSP40/ 100339	Oct, 2015
	X	Horn Antenna	ETS-Lindgren	3117/ 35205	Mar, 2016
	X	Horn Antenna	Schwarzbeck	BBHA9170/209	Jan, 2016
	X	Horn Antenna	TRC	AH-0801/95051	Aug, 2015
	X	Pre-Amplifier	EMCI	EMC012630SE/980210	Jan, 2016
	X	Pre-Amplifier	MITEQ	JS41-001040000-58-5P/153945	Jul, 2015
	X	Pre-Amplifier	NARDA	DBL-1840N506/013	Jul, 2015

- Note: 1. All equipments are calibrated with traceable calibrations. Each calibration is traceable to the national or international standards.
2. The test instruments marked with "X" are used to measure the final test results.

4.2. Test Setup

Below 1GHz

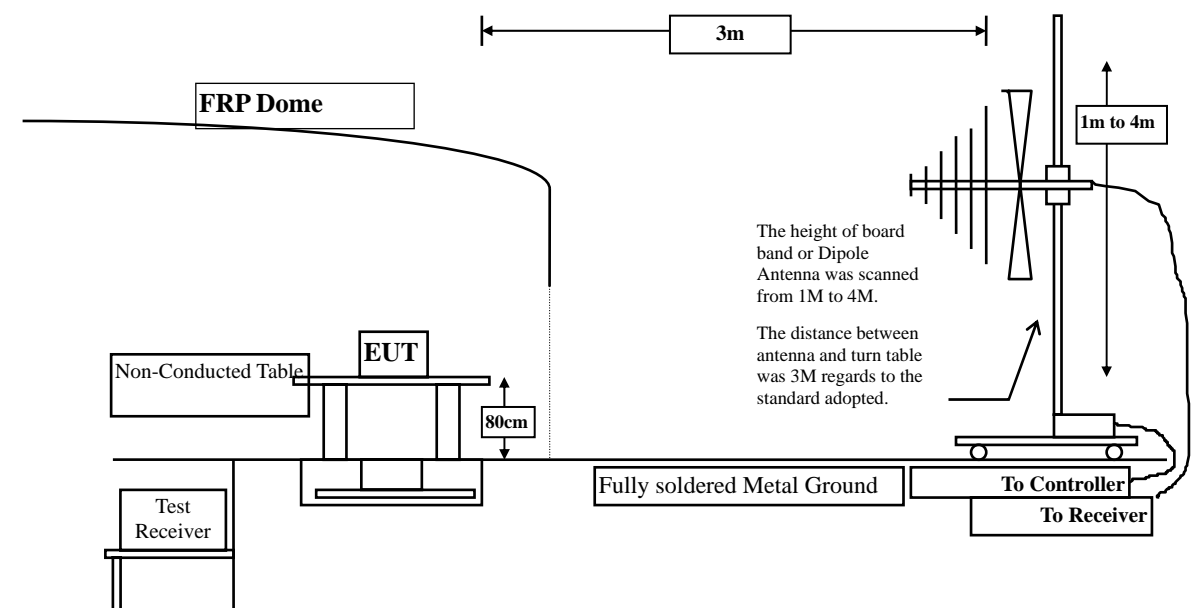

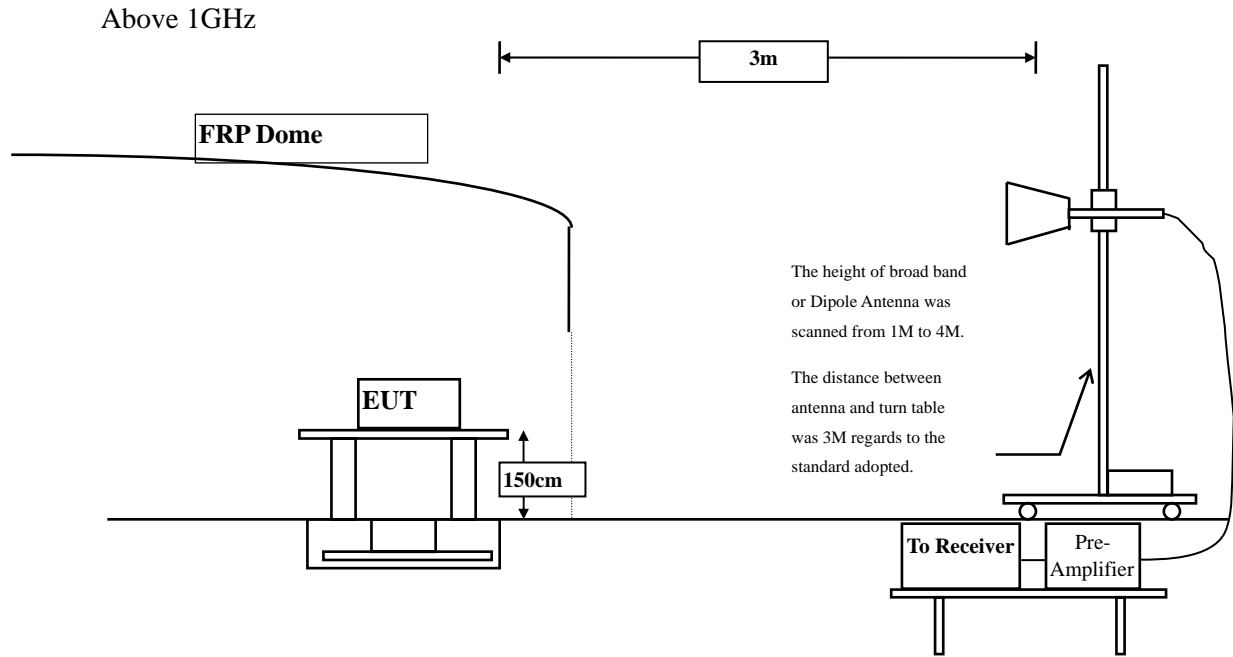

4.3. Limits

➤ General Radiated Emission Limits

Emissions radiated outside of the specified frequency bands, except for harmonics, shall be attenuated by at least 20dB below the level of the fundamental or to the general radiated emission limits in paragraph 15.209, whichever is the lesser attenuation.

FCC Part 15 Subpart C Paragraph 15.209 Limits		
Frequency MHz	Field strength (microvolts/meter)	Measurement distance (meter)
0.009-0.490	2400/F(kHz)	300
0.490-1.705	24000/F(kHz)	30
1.705-30	30	30
30-88	100	3
88-216	150	3
216-960	200	3
Above 960	500	3

- Remarks:
1. RF Voltage (dBuV) = 20 log RF Voltage (uV)
 2. In the Above Table, the tighter limit applies at the band edges.
 3. Distance refers to the distance in meters between the measuring instrument antenna and the closed point of any part of the device or system.

4.4. Test Procedure

The EUT was setup according to ANSI C63.10: 2013 and tested according to DTS test procedure of KDB558074 for compliance to FCC 47CFR 15.247 requirements.

Measuring the frequency range below 1GHz, the EUT is placed on a turn table which is 0.8 meter above ground, when measuring the frequency range above 1GHz, the EUT is placed on a turn table which is 1.5 meter above ground.

The turn table is rotated 360 degrees to determine the position of the maximum emission level.

The EUT was positioned such that the distance from antenna to the EUT was 3 meters.

The antenna is scanned between 1 meter and 4 meters to find out the maximum emission level. This is repeated for both horizontal and vertical polarization of the antenna. In order to find the maximum emission, all of the interface cables were manipulated according to ANSI C63.10: 2013 on radiated measurement.

The resolution bandwidth below 30MHz setting on the field strength meter is 9kHz and 30MHz~1GHz is 120kHz and above 1GHz is 1MHz.

Radiated emission measurements below 30MHz are made using Loop Antenna and 30MHz~1GHz are made using broadband Bilog antenna and above 1GHz are made using Horn Antennas.

The measurement is divided into the Preliminary Measurement and the Final Measurement.

The suspected frequencies are searched for in Preliminary Measurement with the measurement antenna kept pointed at the source of the emission both in azimuth and elevation, with the polarization of the antenna oriented for maximum response. The antenna is pointed at an angle towards the source of the emission, and the EUT is rotated in both height and polarization to maximize the measured emission. The emission is kept within the illumination area of the 3 dB bandwidth of the antenna.

The worst radiated emission is measured in the Open Area Test Site on the Final Measurement.

The measurement frequency range from 9kHz - 10th Harmonic of fundamental was investigated.

4.5. Uncertainty

± 3.9 dB above 1GHz

± 3.8 dB below 1GHz

4.6. Test Result of Radiated Emission

Product : Medical Cart Computer
 Test Item : Harmonic Radiated Emission
 Test Site : No.3 OATS
 Test Mode : Mode 1: Transmit - BLE (GFSK)(2402MHz) (19'')

Frequency MHz	Correct Factor dB	Reading Level dBuV	Measurement Level dBuV/m	Margin dB	Limit dBuV/m
Horizontal					
Peak Detector:					
4804.000	3.331	31.030	34.361	-39.639	74.000
7206.000	10.136	31.780	41.916	-32.084	74.000
9608.000	13.706	32.580	46.286	-27.714	74.000
Average Detector:					
--					
Vertical					
Peak Detector:					
4804.000	6.638	31.020	37.657	-36.343	74.000
7206.000	11.005	31.780	42.785	-31.215	74.000
9608.000	14.103	32.600	46.703	-27.297	74.000
Average Detector:					
--					

Note:

1. All Readings below 1GHz are Quasi-Peak, above 1GHz are performed with peak and/or average measurements as necessary.
2. Peak measurements: RBW = 1MHz, VBW = 3 MHz, Sweep: Auto.
3. Average measurements: RBW = 1MHz, VBW = 10 Hz, Sweep: Auto.
4. Measurement Level = Reading Level + Correct Factor.
5. Correct Factor = Antenna factor + Cable loss – Amplifier gain.
6. The average measurement was not performed when the peak measured data under the limit of average detection.
7. The emission levels of other frequencies are very lower than the limit and not show in test report.

Product : Medical Cart Computer
 Test Item : Harmonic Radiated Emission
 Test Site : No.3 OATS
 Test Mode : Mode 1: Transmit - BLE (GFSK) (2440MHz) (19'')

Frequency MHz	Correct Factor dB	Reading Level dBuV	Measurement Level dBuV/m	Margin dB	Limit dBuV/m
Horizontal					
Peak Detector:					
4880.000	3.010	30.840	33.850	-40.150	74.000
7320.000	11.833	32.190	44.024	-29.976	74.000
9760.000	12.580	33.930	46.511	-27.489	74.000
Average Detector:					
--					
Vertical					
Peak Detector:					
4880.000	5.738	30.950	36.688	-37.312	74.000
7320.000	12.703	32.150	44.853	-29.147	74.000
9760.000	13.052	33.890	46.942	-27.058	74.000
Average Detector:					
--					

Note:

1. All Readings below 1GHz are Quasi-Peak, above 1GHz are performed with peak and/or average measurements as necessary.
2. Peak measurements: RBW = 1MHz, VBW = 3 MHz, Sweep: Auto.
3. Average measurements: RBW = 1MHz, VBW = 10 Hz, Sweep: Auto.
4. Measurement Level = Reading Level + Correct Factor.
5. Correct Factor = Antenna factor + Cable loss – Amplifier gain.
6. The average measurement was not performed when the peak measured data under the limit of average detection.
7. The emission levels of other frequencies are very lower than the limit and not show in test report.

Product : Medical Cart Computer
 Test Item : Harmonic Radiated Emission
 Test Site : No.3 OATS
 Test Mode : Mode 1: Transmit - BLE (GFSK) (2480MHz) (19'')

Frequency MHz	Correct Factor dB	Reading Level dBuV	Measurement Level dBuV/m	Margin dB	Limit dBuV/m
Horizontal					
Peak Detector:					
4960.000	2.760	31.200	33.960	-40.040	74.000
7440.000	12.567	31.780	44.346	-29.654	74.000
9920.000	13.456	32.930	46.386	-27.614	74.000
Average Detector:					
--					
Vertical					
Peak Detector:					
4960.000	5.557	31.190	36.747	-37.253	74.000
7440.000	13.426	31.840	45.265	-28.735	74.000
9920.000	13.958	33.050	47.008	-26.992	74.000
Average Detector:					
--					

Note:

1. All Readings below 1GHz are Quasi-Peak, above 1GHz are performed with peak and/or average measurements as necessary.
2. Peak measurements: RBW = 1MHz, VBW = 3 MHz, Sweep: Auto.
3. Average measurements: RBW = 1MHz, VBW = 10 Hz, Sweep: Auto.
4. Measurement Level = Reading Level + Correct Factor.
5. Correct Factor = Antenna factor + Cable loss – Amplifier gain.
6. The average measurement was not performed when the peak measured data under the limit of average detection.
7. The emission levels of other frequencies are very lower than the limit and not show in test report.

Product : Medical Cart Computer
 Test Item : Harmonic Radiated Emission
 Test Site : No.3 OATS
 Test Mode : Mode 1: Transmit - BLE (GFSK)(2402MHz) (22'')

Frequency MHz	Correct Factor dB	Reading Level dBuV	Measurement Level dBuV/m	Margin dB	Limit dBuV/m
Horizontal					
Peak Detector:					
4804.000	3.327	34.670	37.997	-36.003	74.000
7206.000	10.136	31.300	41.436	-32.564	74.000
9608.000	13.706	30.620	44.326	-29.674	74.000
Average Detector:					
--					
Vertical					
Peak Detector:					
4804.000	6.638	36.050	42.687	-31.313	74.000
7206.000	11.005	31.400	42.405	-31.595	74.000
9608.000	14.103	30.830	44.933	-29.067	74.000
Average Detector:					
--					

Note:

1. All Readings below 1GHz are Quasi-Peak, above 1GHz are performed with peak and/or average measurements as necessary.
2. Peak measurements: RBW = 1MHz, VBW = 3 MHz, Sweep: Auto.
3. Average measurements: RBW = 1MHz, VBW = 10 Hz, Sweep: Auto.
4. Measurement Level = Reading Level + Correct Factor.
5. Correct Factor = Antenna factor + Cable loss – Amplifier gain.
6. The average measurement was not performed when the peak measured data under the limit of average detection.
7. The emission levels of other frequencies are very lower than the limit and not show in test report.

Product : Medical Cart Computer
Test Item : Harmonic Radiated Emission
Test Site : No.3 OATS
Test Mode : Mode 1: Transmit - BLE (GFSK) (2440MHz) (22'')

Frequency MHz	Correct Factor dB	Reading Level dBuV	Measurement Level dBuV/m	Margin dB	Limit dBuV/m
Horizontal					
Peak Detector:					
4880.000	3.010	34.240	37.250	-36.750	74.000
7320.000	11.833	31.460	43.294	-30.706	74.000
9760.000	12.580	30.890	43.471	-30.529	74.000
Average Detector:					
--					
Vertical					
Peak Detector:					
4880.000	5.738	34.400	40.138	-33.862	74.000
7320.000	12.703	31.230	43.933	-30.067	74.000
9760.000	13.052	31.060	44.112	-29.888	74.000
Average Detector:					
--					

Note:

1. All Readings below 1GHz are Quasi-Peak, above 1GHz are performed with peak and/or average measurements as necessary.
2. Peak measurements: RBW = 1MHz, VBW = 3 MHz, Sweep: Auto.
3. Average measurements: RBW = 1MHz, VBW = 10 Hz, Sweep: Auto.
4. Measurement Level = Reading Level + Correct Factor.
5. Correct Factor = Antenna factor + Cable loss – Amplifier gain.
6. The average measurement was not performed when the peak measured data under the limit of average detection.
7. The emission levels of other frequencies are very lower than the limit and not show in test report.

Product : Medical Cart Computer
 Test Item : Harmonic Radiated Emission
 Test Site : No.3 OATS
 Test Mode : Mode 1: Transmit - BLE (GFSK) (2480MHz) (22'')

Frequency MHz	Correct Factor dB	Reading Level dBuV	Measurement Level dBuV/m	Margin dB	Limit dBuV/m
Horizontal					
Peak Detector:					
4960.000	2.760	33.700	36.460	-37.540	74.000
7440.000	12.567	31.960	44.526	-29.474	74.000
9920.000	13.456	33.060	46.516	-27.484	74.000
Average Detector:					
--					
Vertical					
Peak Detector:					
4960.000	5.557	34.070	39.627	-34.373	74.000
7440.000	13.426	31.680	45.105	-28.895	74.000
9920.000	13.958	32.090	46.048	-27.952	74.000
Average Detector:					
--					

Note:

1. All Readings below 1GHz are Quasi-Peak, above 1GHz are performed with peak and/or average measurements as necessary.
2. Peak measurements: RBW = 1MHz, VBW = 3 MHz, Sweep: Auto.
3. Average measurements: RBW = 1MHz, VBW = 10 Hz, Sweep: Auto.
4. Measurement Level = Reading Level + Correct Factor.
5. Correct Factor = Antenna factor + Cable loss – Amplifier gain.
6. The average measurement was not performed when the peak measured data under the limit of average detection.
7. The emission levels of other frequencies are very lower than the limit and not show in test report.

Product : Medical Cart Computer
 Test Item : General Radiated Emission
 Test Site : No.3 OATS
 Test Mode : Mode 1: Transmit - BLE (GFSK) (2440MHz) (19'')

Frequency MHz	Correct Factor dB	Reading Level dBuV	Measurement Level dBuV/m	Margin dB	Limit dBuV/m
Horizontal					
135.435	-10.321	46.508	36.187	-7.313	43.500
311.159	-4.012	34.053	30.041	-15.959	46.000
457.362	0.192	26.952	27.144	-18.856	46.000
642.928	1.436	22.501	23.937	-22.063	46.000
800.377	5.137	26.088	31.225	-14.775	46.000
947.986	6.636	28.527	35.163	-10.837	46.000
Vertical					
141.058	-6.260	43.603	37.343	-6.157	43.500
291.478	-8.068	33.880	25.813	-20.187	46.000
470.014	-4.686	34.196	29.510	-16.490	46.000
600.754	-2.748	34.640	31.892	-14.108	46.000
777.884	2.641	26.288	28.928	-17.072	46.000
970.478	7.689	27.296	34.985	-19.015	54.000

Note:

1. All Readings below 1GHz are Quasi-Peak, above 1GHz are performed with peak and/or average measurements as necessary.
2. Peak measurements: RBW = 1MHz, VBW = 3 MHz, Sweep: Auto.
3. Average measurements: RBW = 1MHz, VBW = 10 Hz, Sweep: Auto.
4. Measurement Level = Reading Level + Correct Factor.
5. Correct Factor = Antenna factor + Cable loss – Amplifier gain.
6. The average measurement was not performed when the peak measured data under the limit of average detection.
7. The emission levels of other frequencies are very lower than the limit and not show in test report.
8. No emission found between lowest internal used/generated frequency to 30MHz.

Product : Medical Cart Computer
 Test Item : General Radiated Emission
 Test Site : No.3 OATS
 Test Mode : Mode 1: Transmit - BLE (GFSK) (2440MHz) (22'')

Frequency MHz	Correct Factor dB	Reading Level dBuV	Measurement Level dBuV/m	Margin dB	Limit dBuV/m
Horizontal					
209.942	-10.994	41.439	30.446	-13.054	43.500
326.623	-4.543	27.374	22.831	-23.169	46.000
423.623	-3.172	21.992	18.820	-27.180	46.000
567.014	1.655	23.363	25.019	-20.981	46.000
710.406	3.595	18.038	21.633	-24.367	46.000
900.188	5.549	24.985	30.534	-15.466	46.000
Vertical					
179.014	-8.515	35.598	27.083	-16.417	43.500
288.667	-8.221	30.217	21.996	-24.004	46.000
436.275	-8.766	28.065	19.299	-26.701	46.000
623.246	-2.659	30.940	28.281	-17.719	46.000
776.478	2.284	24.178	26.462	-19.538	46.000
966.261	8.016	24.029	32.045	-21.955	54.000

Note:

1. All Readings below 1GHz are Quasi-Peak, above 1GHz are performed with peak and/or average measurements as necessary.
2. Peak measurements: RBW = 1MHz, VBW = 3 MHz, Sweep: Auto.
3. Average measurements: RBW = 1MHz, VBW = 10 Hz, Sweep: Auto.
4. Measurement Level = Reading Level + Correct Factor.
5. Correct Factor = Antenna factor + Cable loss – Amplifier gain.
6. The average measurement was not performed when the peak measured data under the limit of average detection.
7. The emission levels of other frequencies are very lower than the limit and not show in test report.
8. No emission found between lowest internal used/generated frequency to 30MHz.

5. RF Antenna Conducted Test

5.1. Test Equipment

	Equipment	Manufacturer	Model No./Serial No.	Last Cal.
	Spectrum Analyzer	R&S	FSP40 / 100170	Jun, 2015
	Spectrum Analyzer	Agilent	E4407B / US39440758	Jun, 2015
X	Spectrum Analyzer	Agilent	N9010A / MY48030495	Apr., 2015

Note: 1. All equipments are calibrated every one year.
2. The test instruments Marked “X” are used to measure the final test results.

5.2. Test Setup

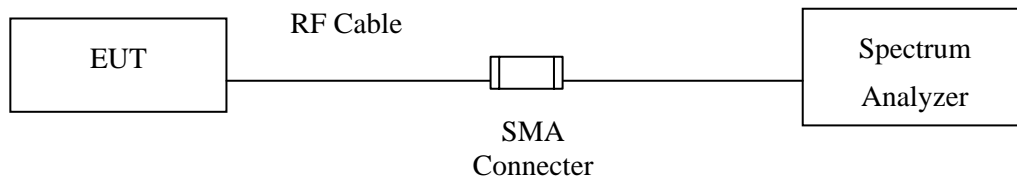

5.3. Limits

According to FCC Section 15.247(d). In any 100 kHz bandwidth outside the frequency band in which the spread spectrum or digitally modulated intentional radiator is operating, the radio frequency power that is produced by the intentional radiator shall be at least 20 dB below that in the 100 kHz bandwidth within the band that contains the highest level of the desired power, based on either an RF conducted or measurement, provided the transmitter demonstrates compliance with the peak conducted power limits. If the transmitter complies with the conducted power limits based on the use of RMS averaging over a time interval, the attenuation required under this paragraph shall be 30 dB instead of 20 dB.

5.4. Test Procedure

The EUT was tested according to DTS test procedure of KDB558074 for compliance to FCC 47CFR 15.247 requirements.

5.5. Uncertainty

± 150Hz

5.6. Test Result of RF Antenna Conducted Test

Product : Medical Cart Computer
Test Item : RF Antenna Conducted Test
Test Site : No.3 OATS
Test Mode : Mode 1: Transmit - BLE (GFSK) (19''+ 22''+ 24'')

Figure Channel 00:

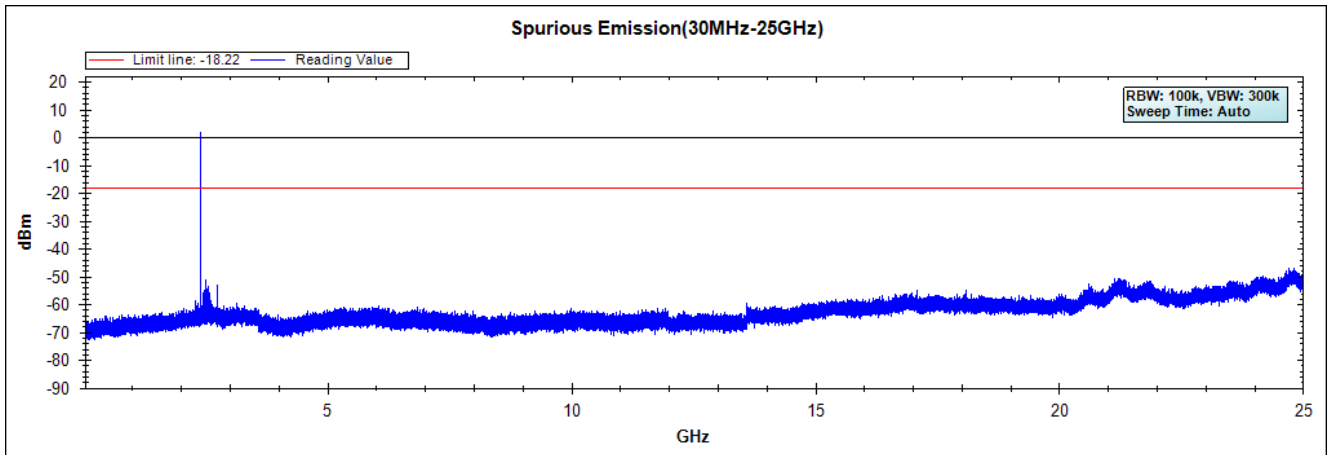

Product : Medical Cart Computer
Test Item : RF Antenna Conducted Test
Test Site : No.3 OATS
Test Mode : Mode 1: Transmit - BLE (GFSK) (19''+ 22''+ 24'')

Figure Channel 19:

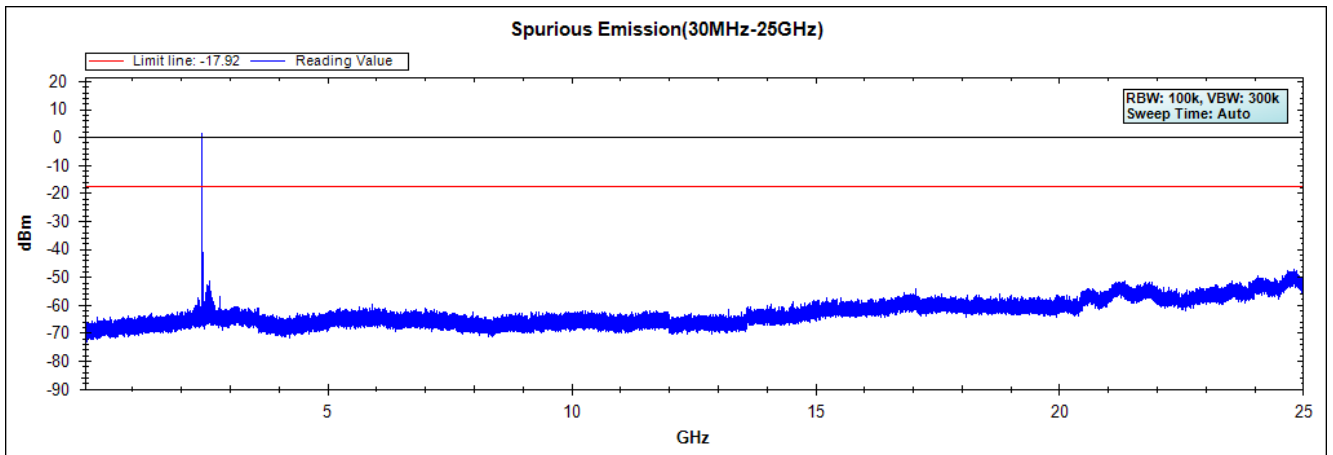

Product : Medical Cart Computer
Test Item : RF Antenna Conducted Test
Test Site : No.3 OATS
Test Mode : Mode 1: Transmit - BLE (GFSK) (19''+ 22''+ 24'')

Figure Channel 39:

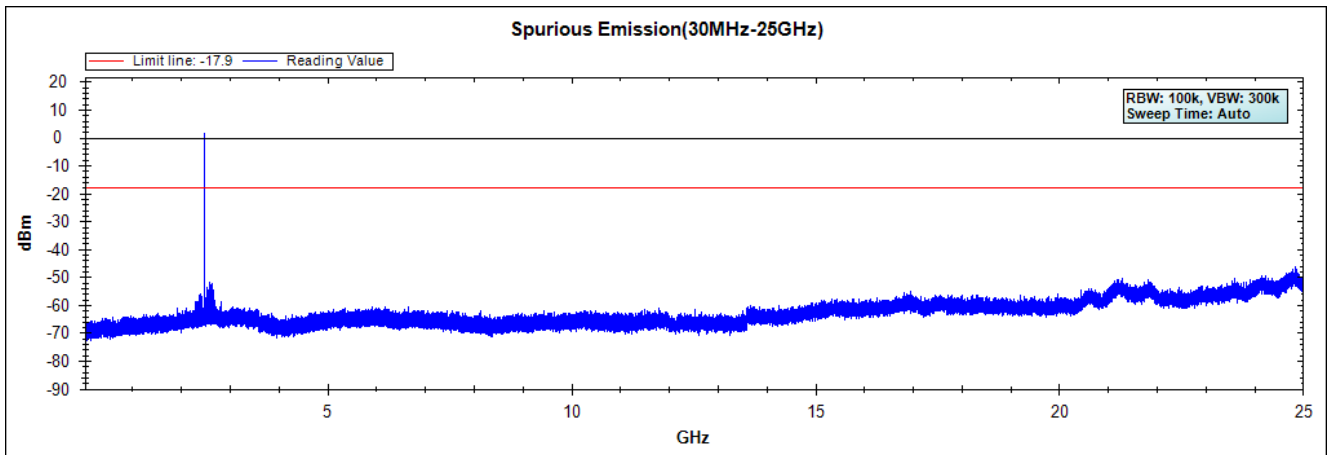

6. Band Edge

6.1. Test Equipment

RF Conducted Measurement

The following test equipments are used during the band edge tests:

	Equipment	Manufacturer	Model No./Serial No.	Last Cal.
	Spectrum Analyzer	R&S	FSP40 / 100170	Jun, 2015
	Spectrum Analyzer	Agilent	E4407B / US39440758	Jun, 2015
X	Spectrum Analyzer	Agilent	N9010A / MY48030495	Apr., 2015

RF Radiated Measurement:

The following test equipments are used during the band edge tests:

Test Site		Equipment	Manufacturer	Model No./Serial No.	Last Cal.
☒ CB # 8	X	Spectrum Analyzer	R&S	FSP40/ 100339	Oct, 2015
	X	Horn Antenna	ETS-Lindgren	3117/ 35205	Mar, 2016
	X	Horn Antenna	Schwarzbeck	BBHA9170/209	Jan, 2016
	X	Horn Antenna	TRC	AH-0801/95051	Aug, 2015
	X	Pre-Amplifier	EMCI	EMC012630SE/980210	Jan, 2016
	X	Pre-Amplifier	MITEQ	JS41-001040000-58-5P/153945	Jul, 2015
	X	Pre-Amplifier	NARDA	DBL-1840N506/013	Jul, 2015

- Note:
1. All equipments are calibrated every one year.
 2. The test instruments marked by "X" are used to measure the final test results.

6.2. Test Setup

RF Conducted Measurement

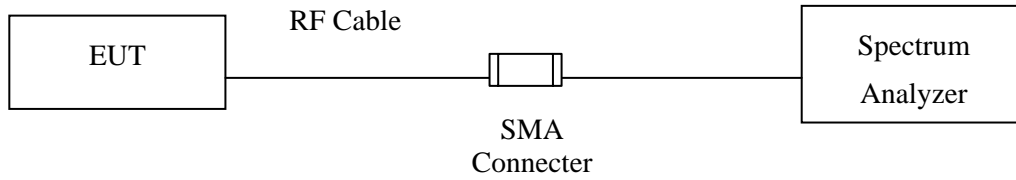

RF Radiated Measurement:

Above 1GHz

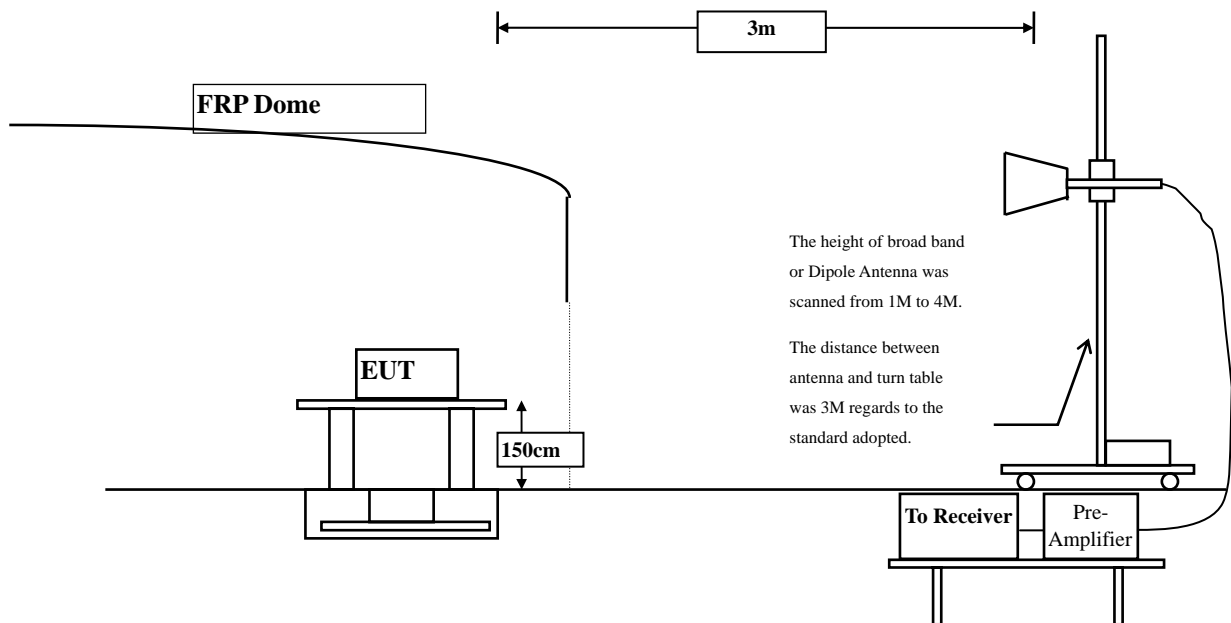

6.3. Limit

In any 100 kHz bandwidth outside the frequency band in which the spread spectrum intentional radiator is operating, the radio frequency power that is produced by the intentional radiator shall be at least 20 dB below that in the 100 kHz bandwidth within the band that contains the highest level of the desired power, based on either an RF conducted or a radiated measurement. Attenuation below the general limits specified in Section 15.209(a) is not required. In addition, radiated emissions which fall in the restricted bands, as defined in Section 15.205(a), must also comply with the radiated emission limits specified in Section 15.209(a) (see Section 15.205(c)).

6.4. Test Procedure

The EUT was setup according to ANSI C63.10, 2013 and tested according to DTS test procedure of KDB558074 for compliance to FCC 47CFR 15.247 requirements.

The EUT is placed on a turn table which is 1.5 meter above ground. The turn table is rotated 360 degrees to determine the position of the maximum emission level. The EUT was positioned such that the distance from antenna to the EUT was 3 meters.

The antenna is scanned from 1 meter to 4 meters to find out the maximum emission level. This is repeated for both horizontal and vertical polarization of the antenna. In order to find the maximum emission, all of the interface cables were manipulated according to ANSI C63.10:2013 on radiated measurement.

6.5. Uncertainty

± 3.9 dB above 1GHz

± 3.8 dB below 1GHz

6.6. Test Result of Band Edge

Product : Medical Cart Computer
 Test Item : Band Edge
 Test Site : No.3 OATS
 Test Mode : Mode 1: Transmit - BLE (GFSK) (19"')

RF Radiated Measurement (Horizontal):

Channel No.	Frequency (MHz)	Correct Factor (dB)	Reading Level (dBuV)	Emission Level (dBuV/m)	Peak Limit (dBuV/m)	Average Limit (dBuV/m)	Result
00 (Peak)	2376.087	31.454	28.352	59.807	74.00	54.00	Pass
00 (Peak)	2390.000	31.509	27.448	58.957	74.00	54.00	Pass
00 (Peak)	2400.000	31.561	35.698	67.259	--	--	--
00 (Peak)	2402.319	31.575	65.348	96.924	--	--	--
00 (Average)	2344.928	31.333	14.567	45.900	74.00	54.00	Pass
00 (Average)	2390.000	31.509	13.543	45.052	74.00	54.00	Pass
00 (Average)	2400.000	31.561	18.021	49.582	--	--	--
00 (Average)	2402.029	31.573	46.920	78.494	--	--	--

Figure Channel 00: Horizontal (Peak)

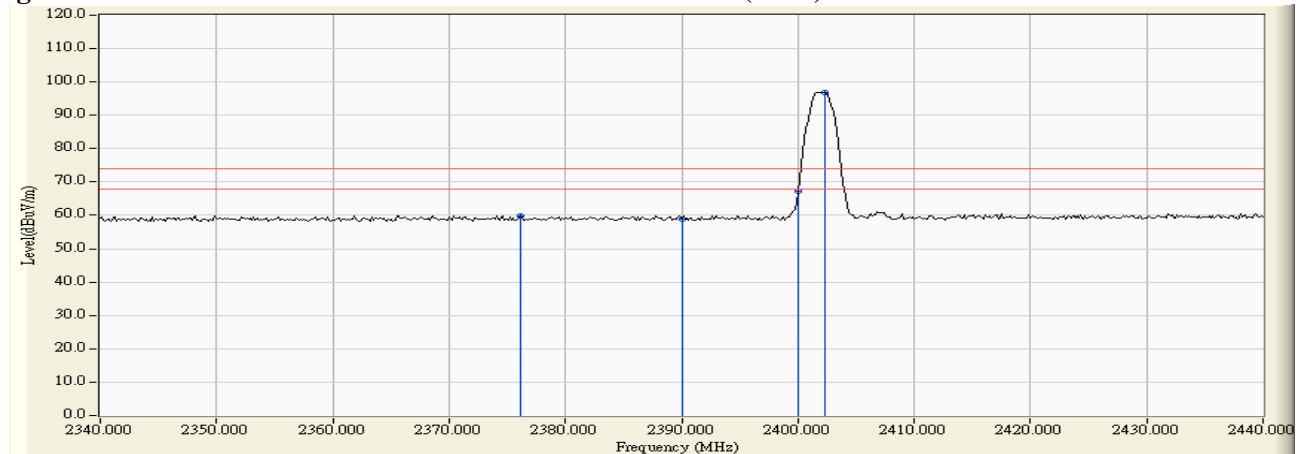
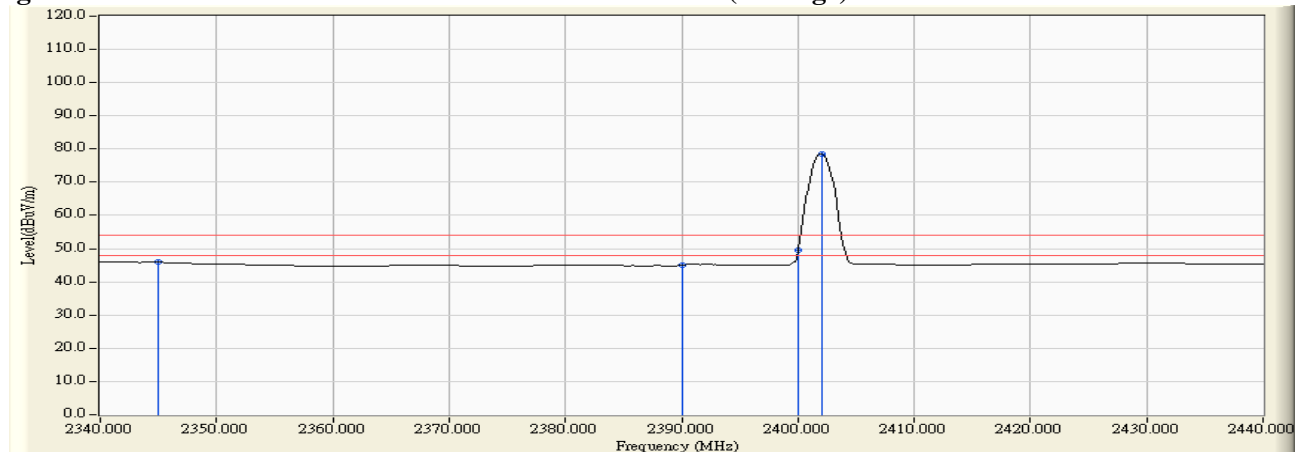

Figure Channel 00: Horizontal (Average)



Note:

1. All readings above 1GHz are performed with peak and/or average measurements as necessary.
2. Peak measurements: RBW = 1MHz, VBW = 3 MHz, Sweep: Auto.
3. Average measurements: RBW = 1MHz, VBW = 10 Hz, Sweep: Auto.
4. “ * ”, means this data is the worst emission level.
5. Measurement Level = Reading Level + Correct Factor.
6. The average measurement was not performed when the peak measured data under the limit of average detection.

Product : Medical Cart Computer
 Test Item : Band Edge
 Test Site : No.3 OATS
 Test Mode : Mode 1: Transmit - BLE (GFSK) (19"")

RF Radiated Measurement (Vertical):

Channel No.	Frequency (MHz)	Correct Factor (dB)	Reading Level (dBuV)	Emission Level (dBuV/m)	Peak Limit (dBuV/m)	Average Limit (dBuV/m)	Result
00 (Peak)	2389.420	30.918	28.894	59.812	74.00	54.00	Pass
00 (Peak)	2390.000	30.915	27.649	58.564	74.00	54.00	Pass
00 (Peak)	2400.000	30.912	35.029	65.941	--	--	--
00 (Peak)	2402.319	30.918	65.557	96.475	--	--	--
00 (Average)	2342.464	31.135	14.714	45.850	74.00	54.00	Pass
00 (Average)	2390.000	30.915	13.741	44.656	74.00	54.00	Pass
00 (Average)	2400.000	30.912	18.234	49.146	--	--	--
00 (Average)	2402.029	30.917	47.036	77.953	--	--	--

Figure Channel 00: Vertical (Peak)

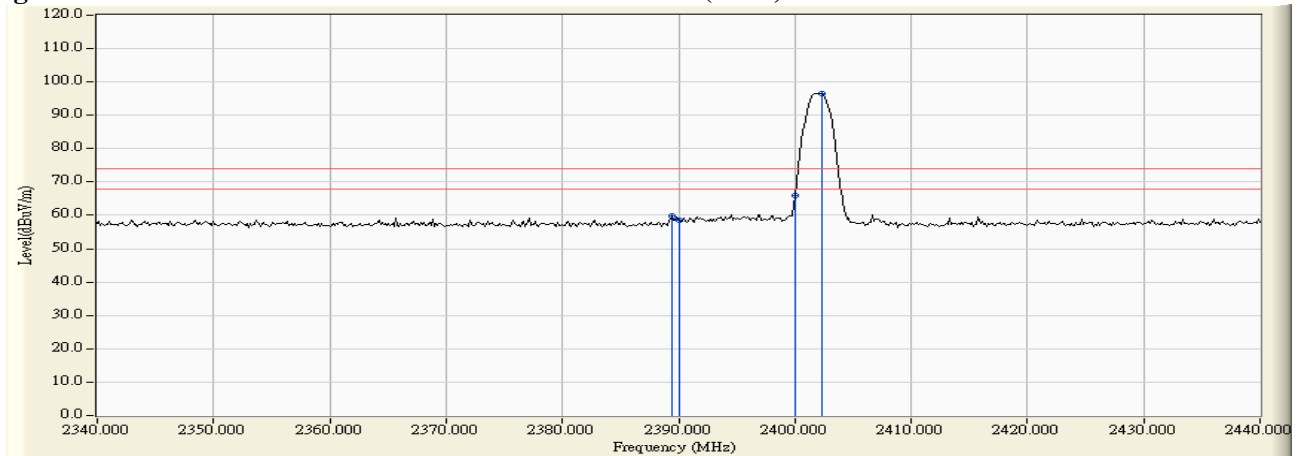
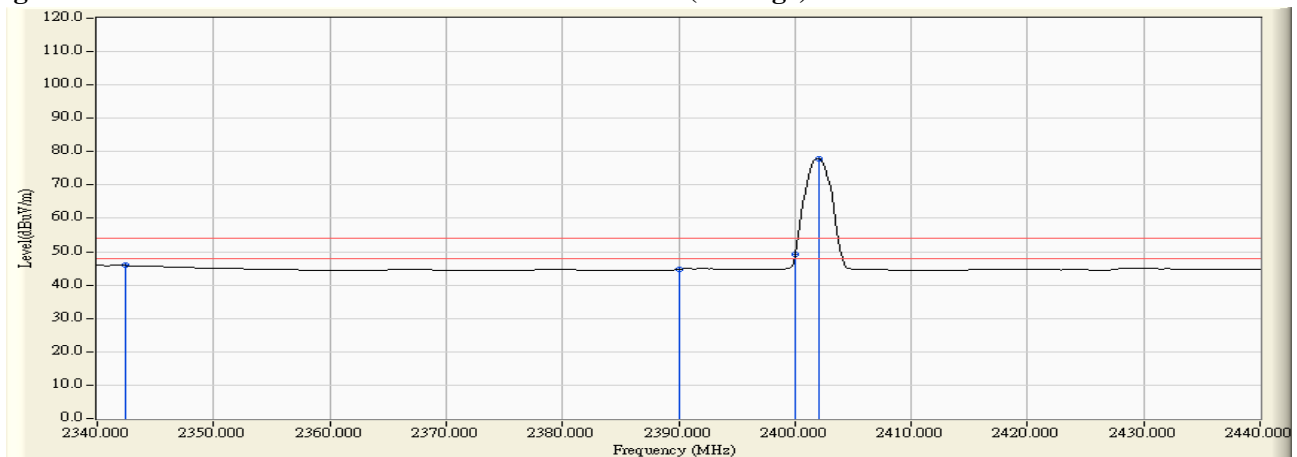

Figure Channel 00: Vertical (Average)



Note:

1. All readings above 1GHz are performed with peak and/or average measurements as necessary.
2. Peak measurements: RBW = 1MHz, VBW = 3 MHz, Sweep: Auto.
3. Average measurements: RBW = 1MHz, VBW = 10 Hz, Sweep: Auto.
4. “ * ”, means this data is the worst emission level.
5. Measurement Level = Reading Level + Correct Factor.
6. The average measurement was not performed when the peak measured data under the limit of average detection.

Product : Medical Cart Computer
 Test Item : Band Edge
 Test Site : No.3 OATS
 Test Mode : Mode 1: Transmit - BLE (GFSK) (19")

RF Radiated Measurement (Horizontal):

Channel No.	Frequency (MHz)	Correct Factor (dB)	Reading Level (dBuV)	Emission Level (dBuV/m)	Peak Limit (dBuV/m)	Average Limit (dBuV/m)	Result
39 (Peak)	2479.732	32.154	66.748	98.902	--	--	--
39 (Peak)	2483.500	32.182	27.101	59.283	74.00	54.00	Pass
39 (Peak)	2484.804	32.193	29.730	61.922	74.00	54.00	Pass
39 (Average)	2480.022	32.156	48.057	80.213	--	--	--
39 (Average)	2483.500	32.182	14.054	46.236	74.00	54.00	Pass
39 (Average)	2509.152	32.254	15.415	47.669	74.00	54.00	Pass

Figure Channel 39: Horizontal (Peak)

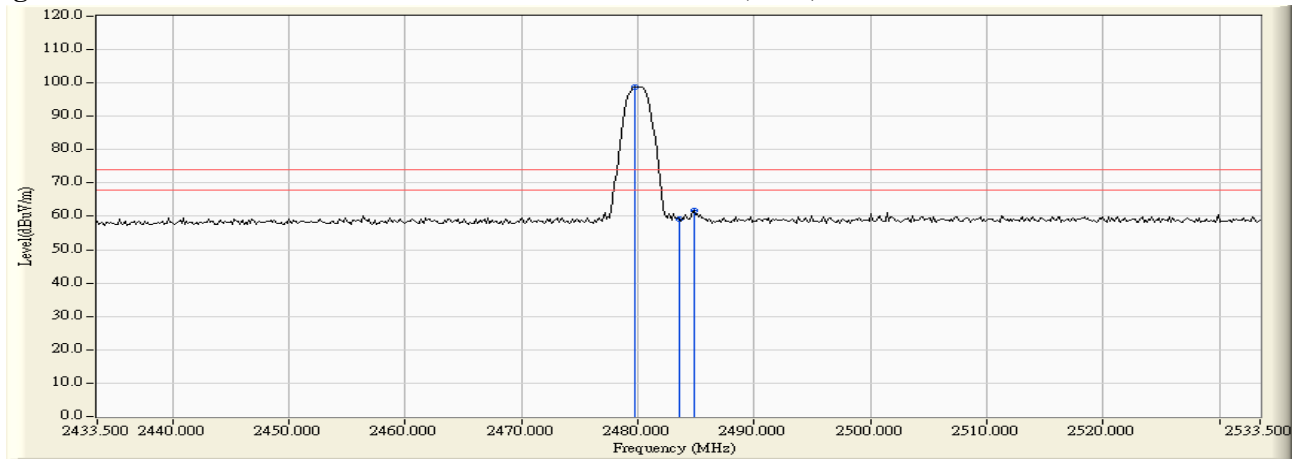
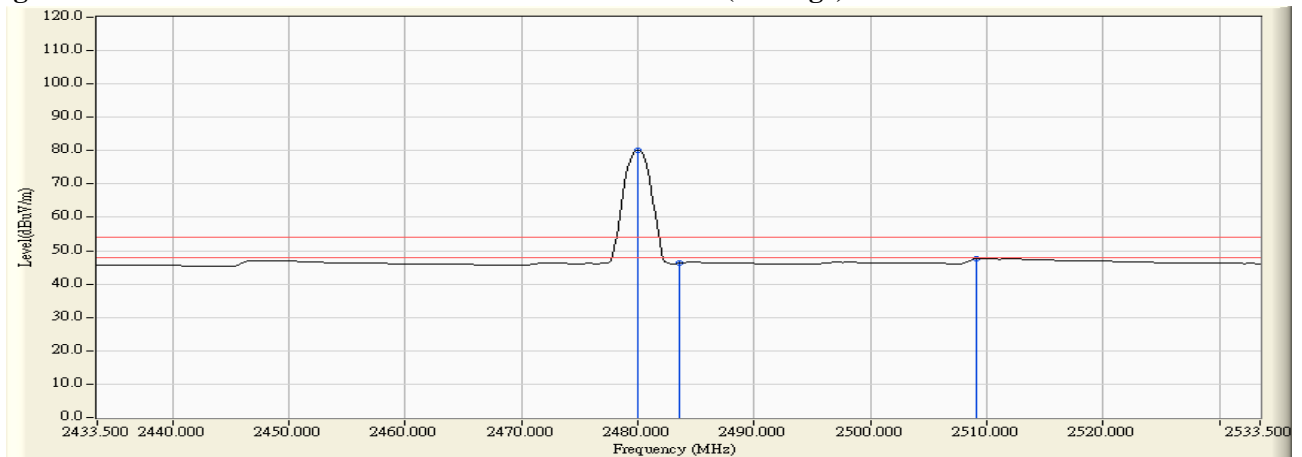

Figure Channel 39: Horizontal (Average)



Note:

1. All readings above 1GHz are performed with peak and/or average measurements as necessary.
2. Peak measurements: RBW = 1MHz, VBW = 3 MHz, Sweep: Auto.
3. Average measurements: RBW = 1MHz, VBW = 10 Hz, Sweep: Auto.
4. “ * ”, means this data is the worst emission level.
5. Measurement Level = Reading Level + Correct Factor.
6. The average measurement was not performed when the peak measured data under the limit of average detection.

Product : Medical Cart Computer
 Test Item : Band Edge
 Test Site : No.3 OATS
 Test Mode : Mode 1: Transmit - BLE (GFSK) (19")

RF Radiated Measurement (Vertical):

Channel No.	Frequency (MHz)	Correct Factor (dB)	Reading Level (dBuV)	Emission Level (dBuV/m)	Peak Limit (dBuV/m)	Average Limit (dBuV/m)	Result
39 (Peak)	2479.732	31.410	68.370	99.780	--	--	--
39 (Peak)	2483.500	31.435	27.180	58.615	74.00	54.00	Pass
39 (Peak)	2485.239	31.447	30.292	61.739	74.00	54.00	Pass
39 (Average)	2480.022	31.412	49.104	80.516	--	--	--
39 (Average)	2483.500	31.435	14.086	45.521	74.00	54.00	Pass
39 (Average)	2509.297	31.546	15.429	46.975	74.00	54.00	Pass

Figure Channel 39: Vertical (Peak)

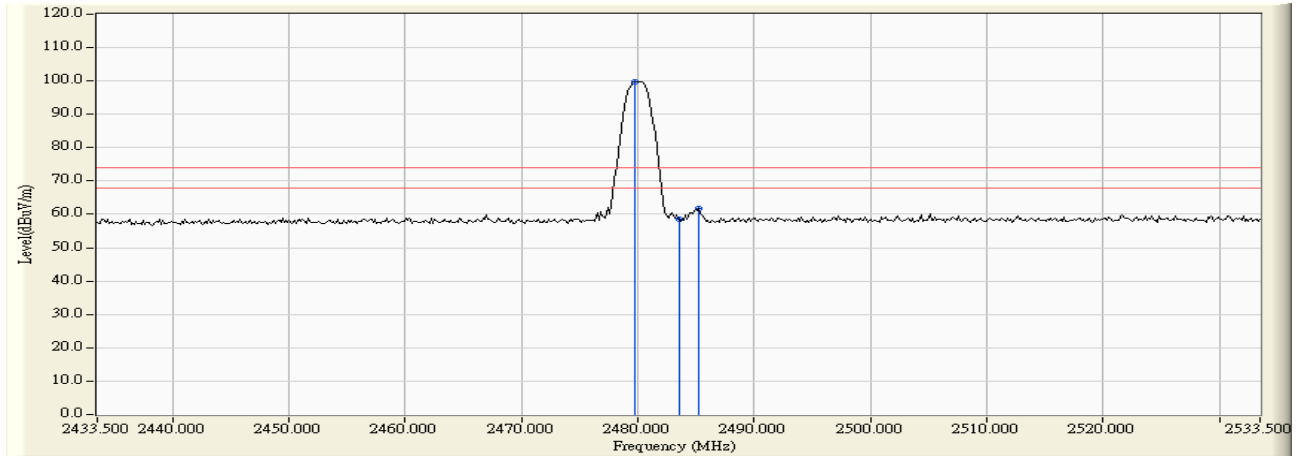
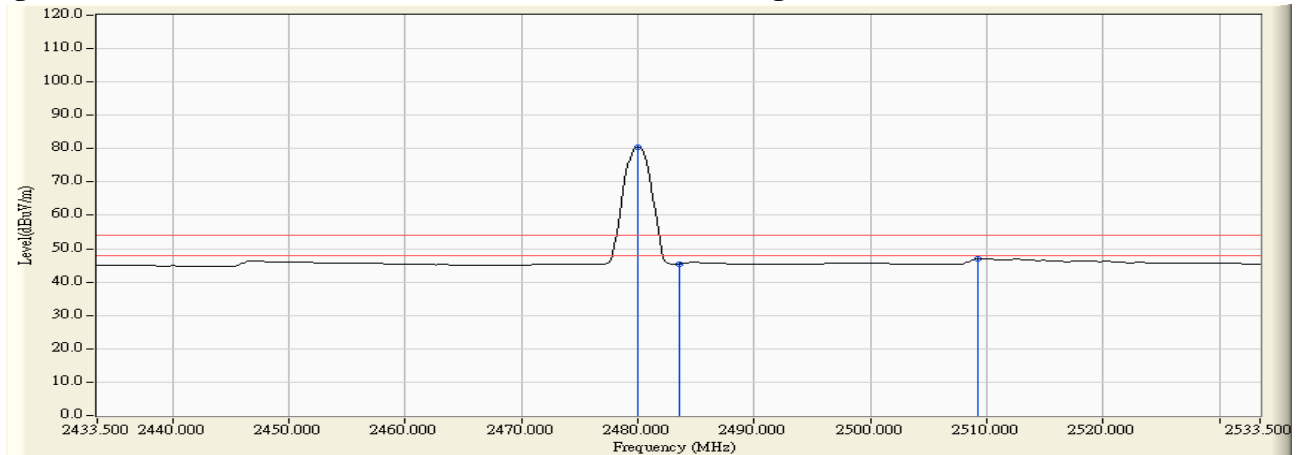

Figure Channel 39: Vertical (Average)



Note:

1. All readings above 1GHz are performed with peak and/or average measurements as necessary.
2. Peak measurements: RBW = 1MHz, VBW = 3 MHz, Sweep: Auto.
3. Average measurements: RBW = 1MHz, VBW = 10 Hz, Sweep: Auto.
4. “ * ”, means this data is the worst emission level.
5. Measurement Level = Reading Level + Correct Factor.
6. The average measurement was not performed when the peak measured data under the limit of average detection.

Product : Medical Cart Computer
 Test Item : Band Edge
 Test Site : No.3 OATS
 Test Mode : Mode 1: Transmit - BLE (GFSK) (22")

RF Radiated Measurement (Horizontal):

Channel No.	Frequency (MHz)	Correct Factor (dB)	Reading Level (dBuV)	Emission Level (dBuV/m)	Peak Limit (dBuV/m)	Average Limit (dBuV/m)	Result
00 (Peak)	2345.362	-1.306	48.659	47.353	74.00	54.00	Pass
00 (Peak)	2390.000	-1.131	48.432	47.301	74.00	54.00	Pass
00 (Peak)	2400.000	-1.084	65.494	64.411	--	--	--
00 (Peak)	2402.029	-1.073	89.583	88.511	--	--	--
00 (Average)	2350.870	-1.284	34.058	32.774	74.00	54.00	Pass
00 (Average)	2390.000	-1.131	33.651	32.520	74.00	54.00	Pass
00 (Average)	2400.000	-1.084	42.855	41.772	--	--	--
00 (Average)	2402.029	-1.073	68.019	66.947	--	--	--

Figure Channel 00: Horizontal (Peak)

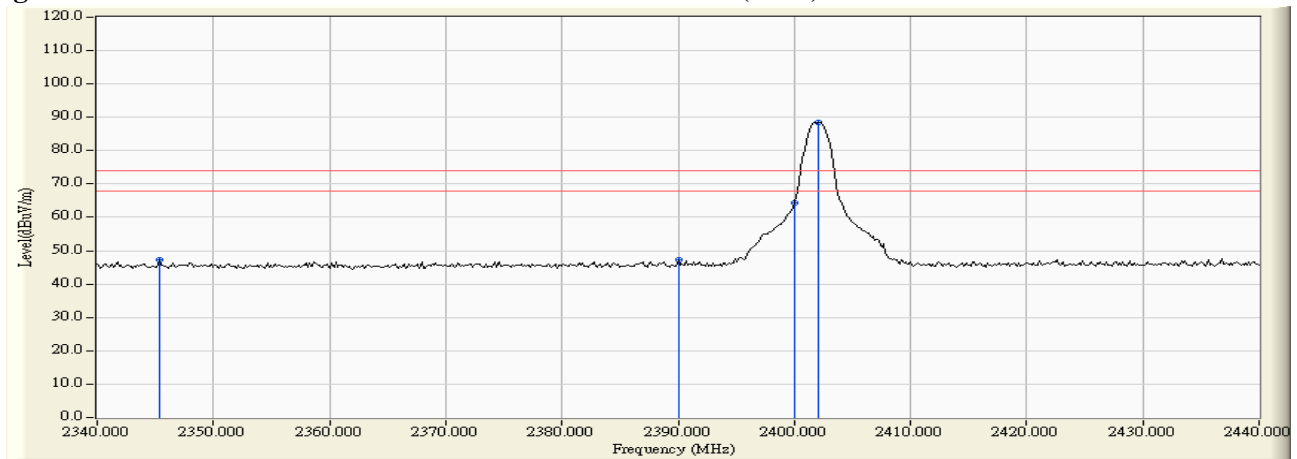
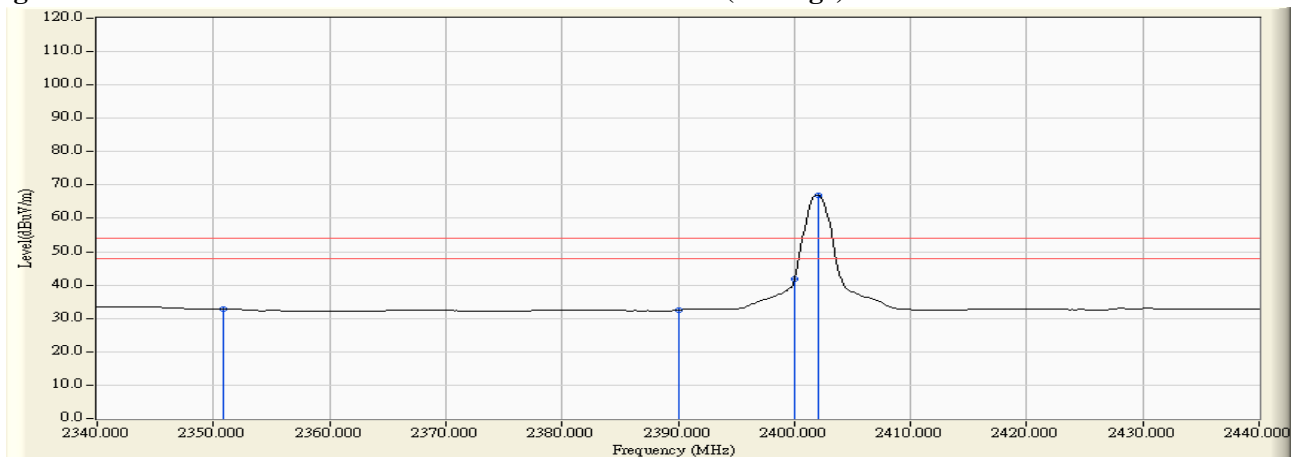

Figure Channel 00: Horizontal (Average)



Note:

1. All readings above 1GHz are performed with peak and/or average measurements as necessary.
2. Peak measurements: RBW = 1MHz, VBW = 3 MHz, Sweep: Auto.
3. Average measurements: RBW = 1MHz, VBW = 10 Hz, Sweep: Auto.
4. “ * ”, means this data is the worst emission level.
5. Measurement Level = Reading Level + Correct Factor.
6. The average measurement was not performed when the peak measured data under the limit of average detection.

Product : Medical Cart Computer
 Test Item : Band Edge
 Test Site : No.3 OATS
 Test Mode : Mode 1: Transmit - BLE (GFSK) (22")

RF Radiated Measurement (Vertical):

Channel No.	Frequency (MHz)	Correct Factor (dB)	Reading Level (dBuV)	Emission Level (dBuV/m)	Peak Limit (dBuV/m)	Average Limit (dBuV/m)	Result
00 (Peak)	2387.971	-1.715	47.382	45.667	74.00	54.00	Pass
00 (Peak)	2390.000	-1.725	46.052	44.327	74.00	54.00	Pass
00 (Peak)	2400.000	-1.733	60.420	58.688	--	--	--
00 (Peak)	2401.739	-1.730	84.317	82.588	--	--	--
00 (Average)	2377.826	-1.668	33.727	32.059	74.00	54.00	Pass
00 (Average)	2390.000	-1.725	33.634	31.909	74.00	54.00	Pass
00 (Average)	2400.000	-1.733	39.890	38.158	--	--	--
00 (Average)	2402.029	-1.729	64.398	62.669	--	--	--

Figure Channel 00: Vertical (Peak)

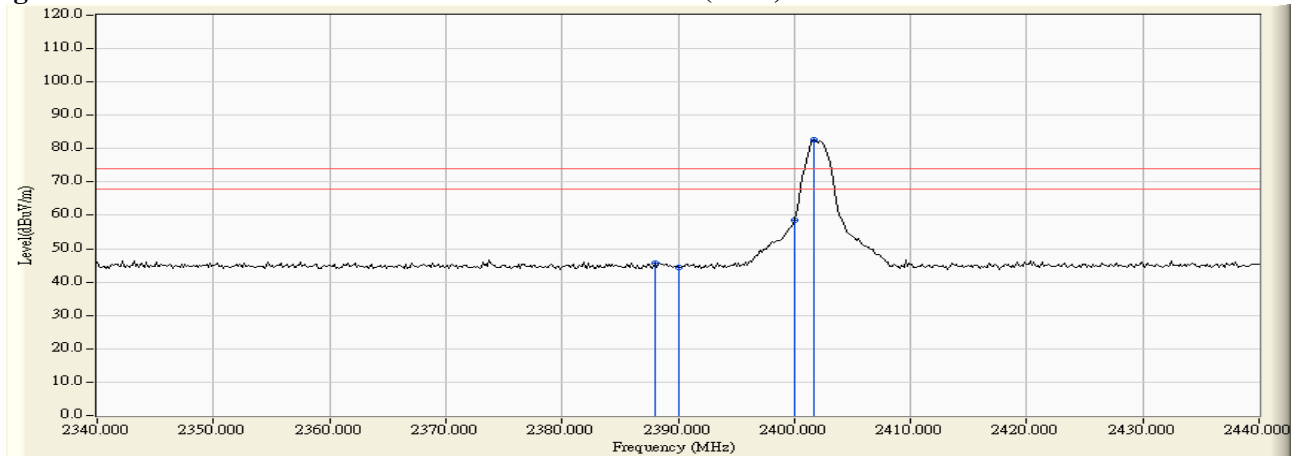
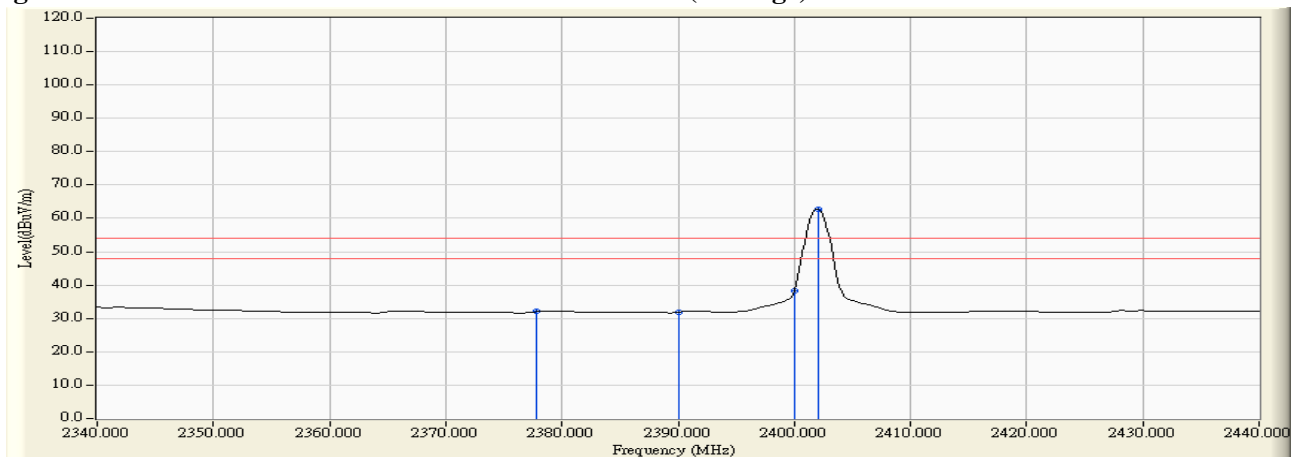

Figure Channel 00: Vertical (Average)



Note:

1. All readings above 1GHz are performed with peak and/or average measurements as necessary.
2. Peak measurements: RBW = 1MHz, VBW = 3 MHz, Sweep: Auto.
3. Average measurements: RBW = 1MHz, VBW = 10 Hz, Sweep: Auto.
4. “ * ”, means this data is the worst emission level.
5. Measurement Level = Reading Level + Correct Factor.
6. The average measurement was not performed when the peak measured data under the limit of average detection.

Product : Medical Cart Computer
 Test Item : Band Edge
 Test Site : No.3 OATS
 Test Mode : Mode 1: Transmit - BLE (GFSK) (22")

RF Radiated Measurement (Horizontal):

Channel No.	Frequency (MHz)	Correct Factor (dB)	Reading Level (dBuV)	Emission Level (dBuV/m)	Peak Limit (dBuV/m)	Average Limit (dBuV/m)	Result
39 (Peak)	2480.167	-0.579	92.949	92.370	--	--	--
39 (Peak)	2483.500	-0.558	61.010	60.452	74.00	54.00	Pass
39 (Average)	2480.022	-0.580	70.885	70.305	--	--	--
39 (Average)	2483.500	-0.558	39.869	39.311	74.00	54.00	Pass

Figure Channel 39: Horizontal (Peak)

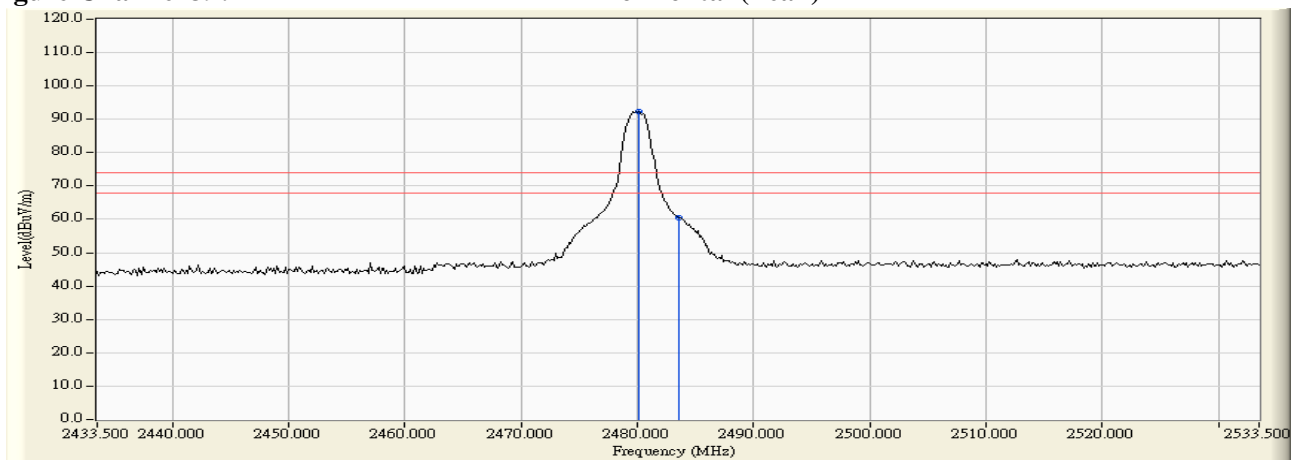
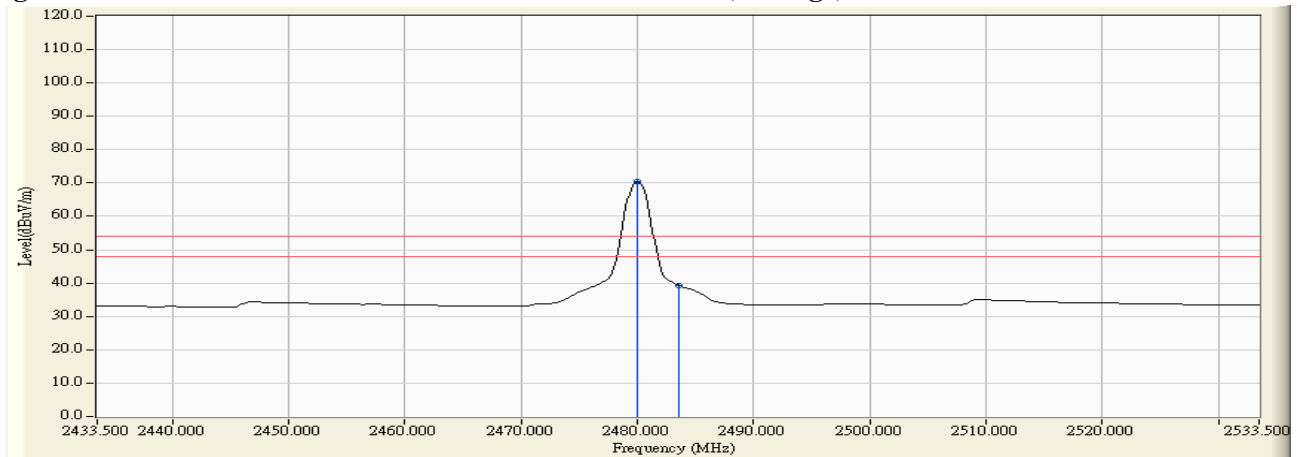

Figure Channel 39: Horizontal (Average)



Note:

1. All readings above 1GHz are performed with peak and/or average measurements as necessary.
2. Peak measurements: RBW = 1MHz, VBW = 3 MHz, Sweep: Auto.
3. Average measurements: RBW = 1MHz, VBW = 10 Hz, Sweep: Auto.
4. “ * ”, means this data is the worst emission level.
5. Measurement Level = Reading Level + Correct Factor.
6. The average measurement was not performed when the peak measured data under the limit of average detection.

Product : Medical Cart Computer
 Test Item : Band Edge
 Test Site : No.3 OATS
 Test Mode : Mode 1: Transmit - BLE (GFSK) (22")

RF Radiated Measurement (Vertical):

Channel No.	Frequency (MHz)	Correct Factor (dB)	Reading Level (dBuV)	Emission Level (dBuV/m)	Peak Limit (dBuV/m)	Average Limit (dBuV/m)	Result
39 (Peak)	2480.022	-1.324	91.032	89.708	--	--	--
39 (Peak)	2483.500	-1.305	59.498	58.193	74.00	54.00	Pass
39 (Average)	2480.022	-1.324	69.493	68.169	--	--	--
39 (Average)	2483.500	-1.305	38.864	37.559	74.00	54.00	Pass

Figure Channel 39: Vertical (Peak)

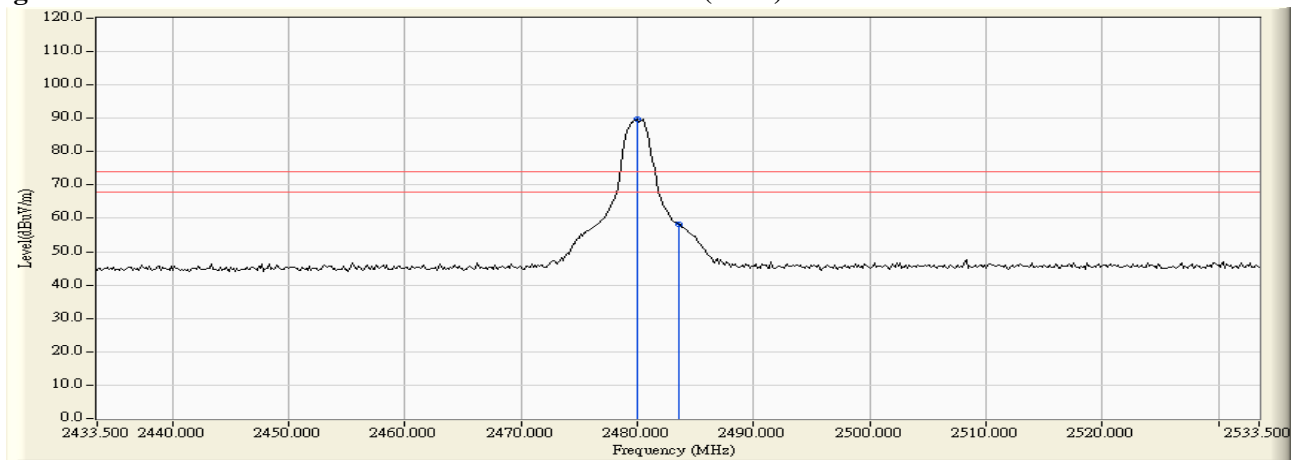
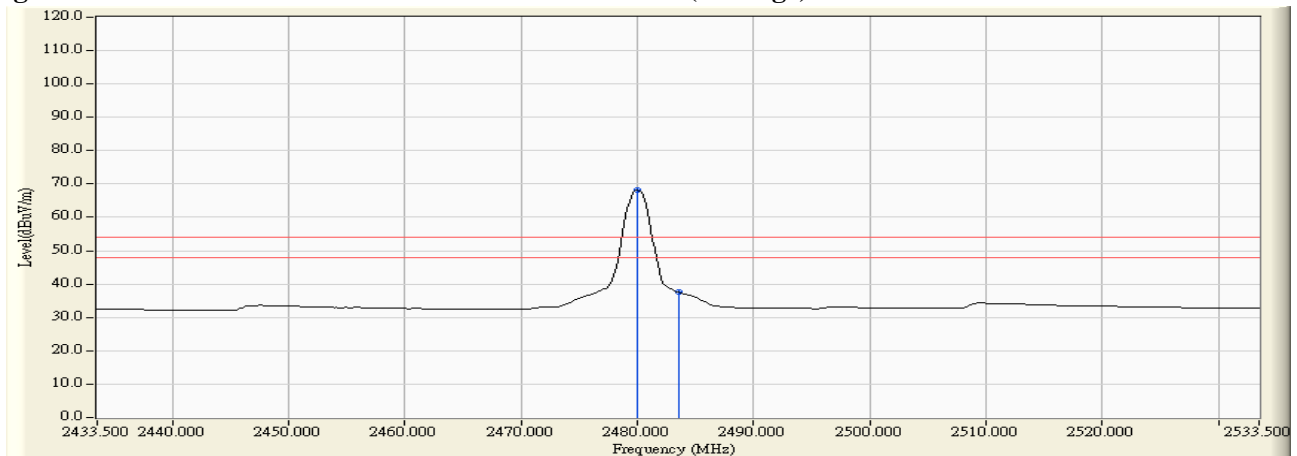

Figure Channel 39: Vertical (Average)



Note:

1. All readings above 1GHz are performed with peak and/or average measurements as necessary.
2. Peak measurements: RBW = 1MHz, VBW = 3 MHz, Sweep: Auto.
3. Average measurements: RBW = 1MHz, VBW = 10 Hz, Sweep: Auto.
4. “ * ”, means this data is the worst emission level.
5. Measurement Level = Reading Level + Correct Factor.
6. The average measurement was not performed when the peak measured data under the limit of average detection.

7. Occupied Bandwidth (6dB BW)

7.1. Test Equipment

	Equipment	Manufacturer	Model No./Serial No.	Last Cal.
	Spectrum Analyzer	R&S	FSP40 / 100170	Jun, 2015
	Spectrum Analyzer	Agilent	E4407B / US39440758	Jun, 2015
X	Spectrum Analyzer	Agilent	N9010A / MY48030495	Apr., 2015

Note:

1. All equipments are calibrated with traceable calibrations. Each calibration is traceable to the national or international standards.
2. The test instruments marked with “X” are used to measure the final test results.

7.2. Test Setup

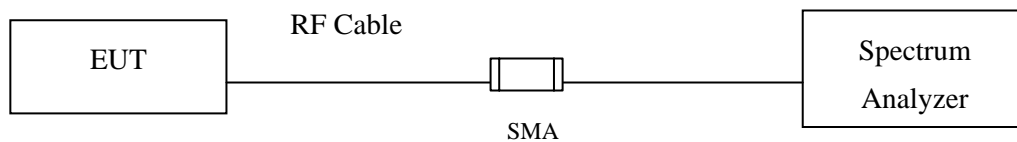

7.3. Limits

The minimum bandwidth shall be at least 500 kHz.

7.4. Test Procedure

The EUT was setup according to ANSI C63.10 2013; tested according to DTS test procedure of KDB558074 for compliance to FCC 47CFR 15.247 requirements.

Set RBW = 1-5% of the emission bandwidth, VBW \geq 3*RBW

7.5. Uncertainty

$\pm 150\text{Hz}$

7.6. Test Result of Occupied Bandwidth

Product : Medical Cart Computer
 Test Item : Occupied Bandwidth Data
 Test Site : No.3 OATS
 Test Mode : Mode 1: Transmit - BLE (GFSK) (2402MHz) (19''+22''+24'')

Channel No.	Frequency (MHz)	Measurement Level (kHz)	Required Limit (kHz)	Result
00	2402	700	>500	Pass

Figure Channel 00:

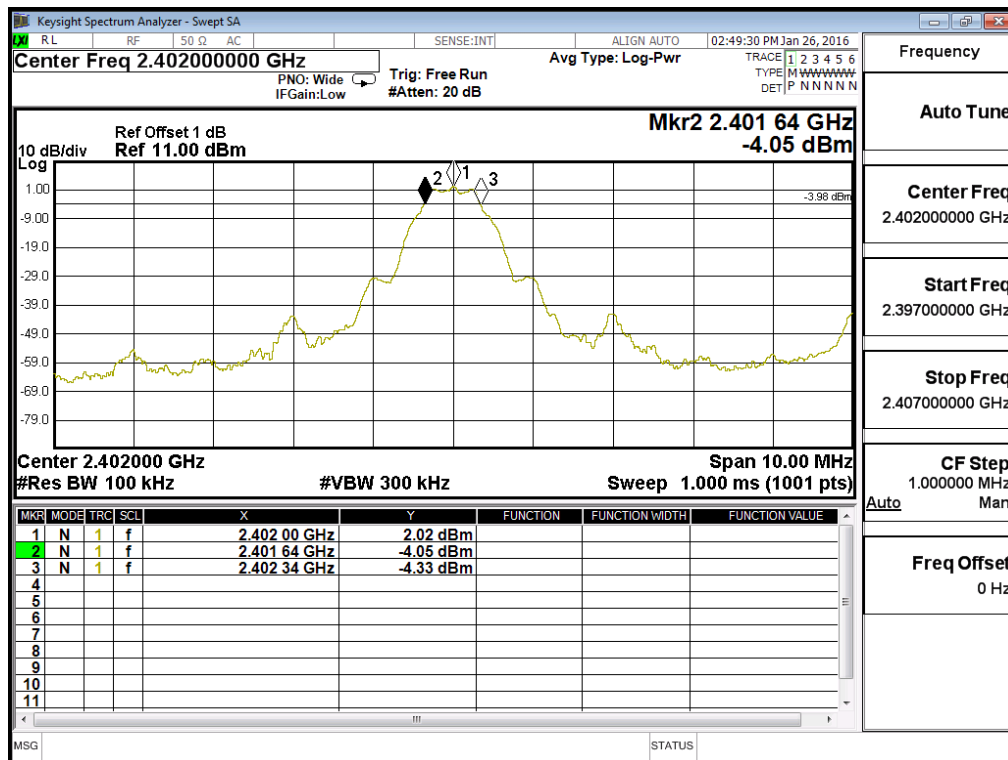

Product : Medical Cart Computer
 Test Item : Occupied Bandwidth Data
 Test Site : No.3 OATS
 Test Mode : Mode 1: Transmit - BLE (GFSK) (2440MHz) (19'' +22''+24'')

Channel No.	Frequency (MHz)	Measurement Level (kHz)	Required Limit (kHz)	Result
19	2440	720	>500	Pass

Figure Channel 19:

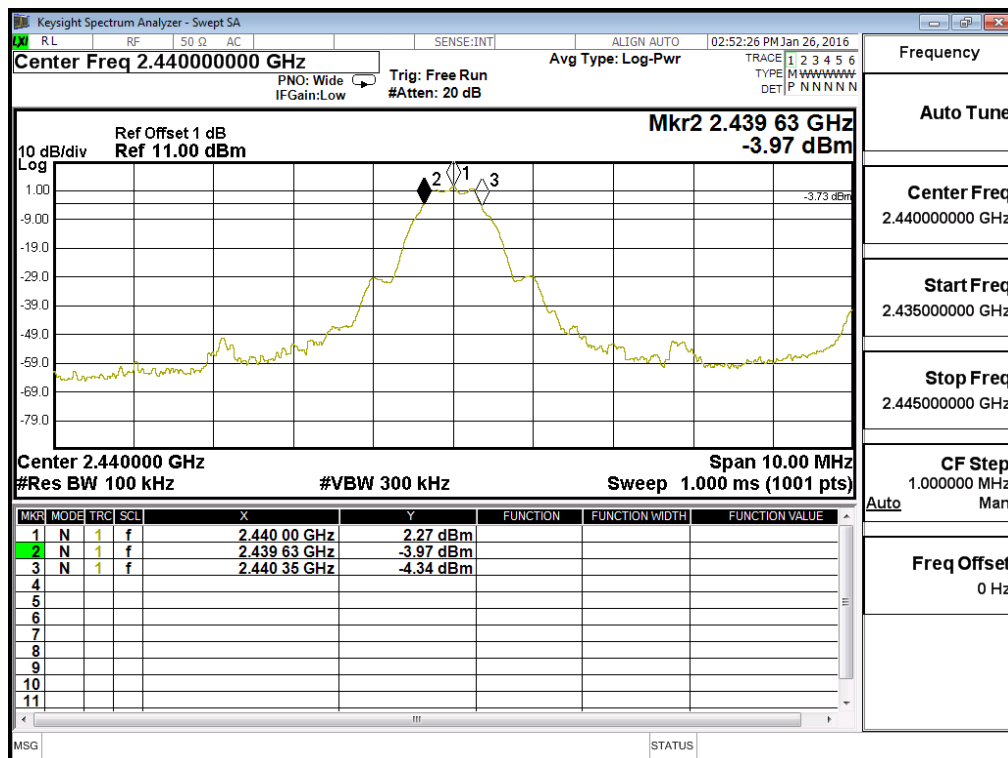

Product : Medical Cart Computer
 Test Item : Occupied Bandwidth Data
 Test Site : No.3 OATS
 Test Mode : Mode 1: Transmit - BLE (GFSK) (2480MHz) (19''+22''+24'')

Channel No.	Frequency (MHz)	Measurement Level (kHz)	Required Limit (kHz)	Result
39	2480	710	>500	Pass

Figure Channel 39:

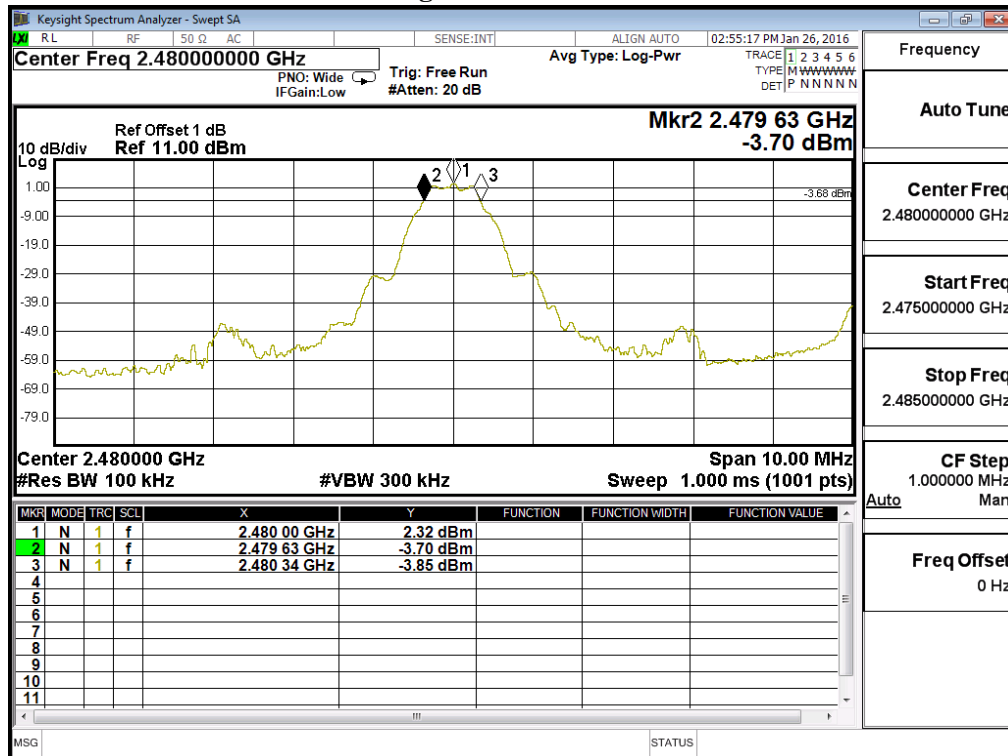

8. Power Density

8.1. Test Equipment

	Equipment	Manufacturer	Model No./Serial No.	Last Cal.
	Spectrum Analyzer	R&S	FSP40 / 100170	Jun, 2015
	Spectrum Analyzer	Agilent	E4407B / US39440758	Jun, 2015
X	Spectrum Analyzer	Agilent	N9010A / MY48030495	Apr., 2015

Note:

1. All equipments are calibrated with traceable calibrations. Each calibration is traceable to the national or international standards.
2. The test instruments marked with “X” are used to measure the final test results.

8.2. Test Setup

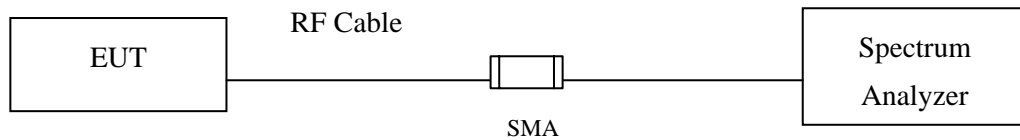

8.3. Limits

The transmitted power density averaged over any 1 second interval shall not be greater +8dBm in any 3kHz bandwidth.

8.4. Test Procedure

The EUT was setup according to ANSI C63.10: 2013, the maximum power spectral density using KDB 558074 section 10.2 PKPSD (peak PSD) method.

8.5. Uncertainty

± 1.27 dB

8.6. Test Result of Power Density

Product : Medical Cart Computer
 Test Item : Power Density Data
 Test Site : No.3 OATS
 Test Mode : Mode 1: Transmit - BLE (GFSK) (2402MHz) (19''+22''+24'')

Channel No.	Frequency (MHz)	Measure Level (dBm)	Limit (dBm)	Result
00	2402	1.780	≤ 8dBm	Pass

Figure Channel 00:

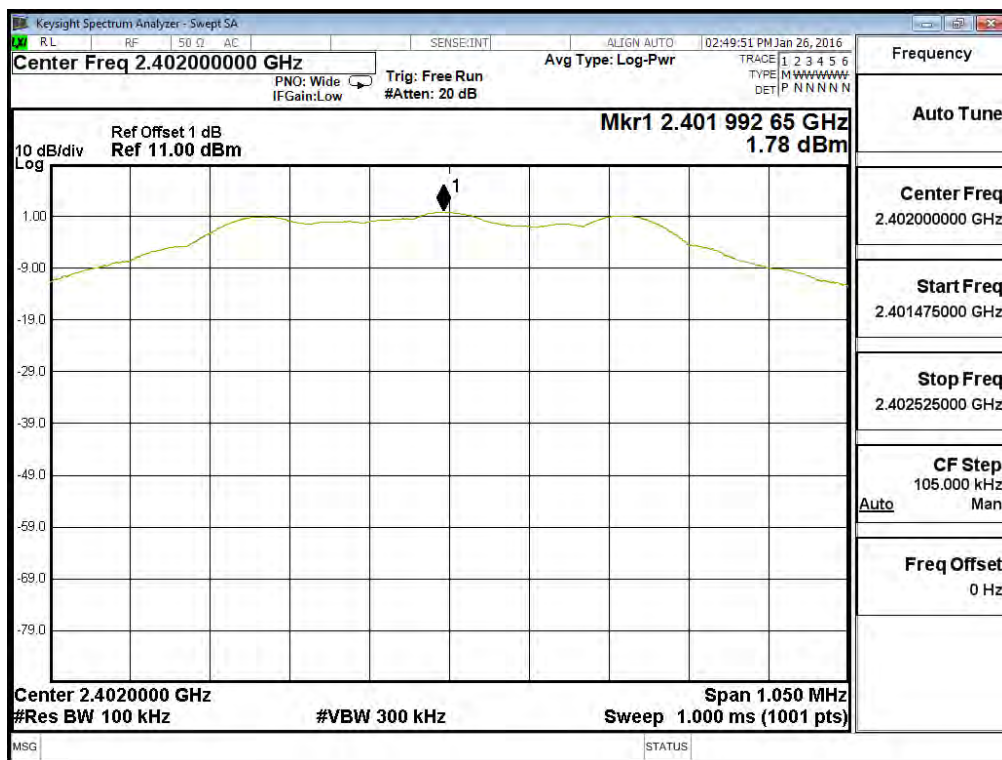

Product : Medical Cart Computer
 Test Item : Power Density Data
 Test Site : No.3OATS
 Test Mode : Mode 1: Transmit - BLE (GFSK) (2440MHz) (19''+22''+24'')

Channel No.	Frequency (MHz)	Measurement Level (dBm)	Required Limit (dBm)	Result
19	2440	2.080	≤ 8dBm	Pass

Figure Channel 19:

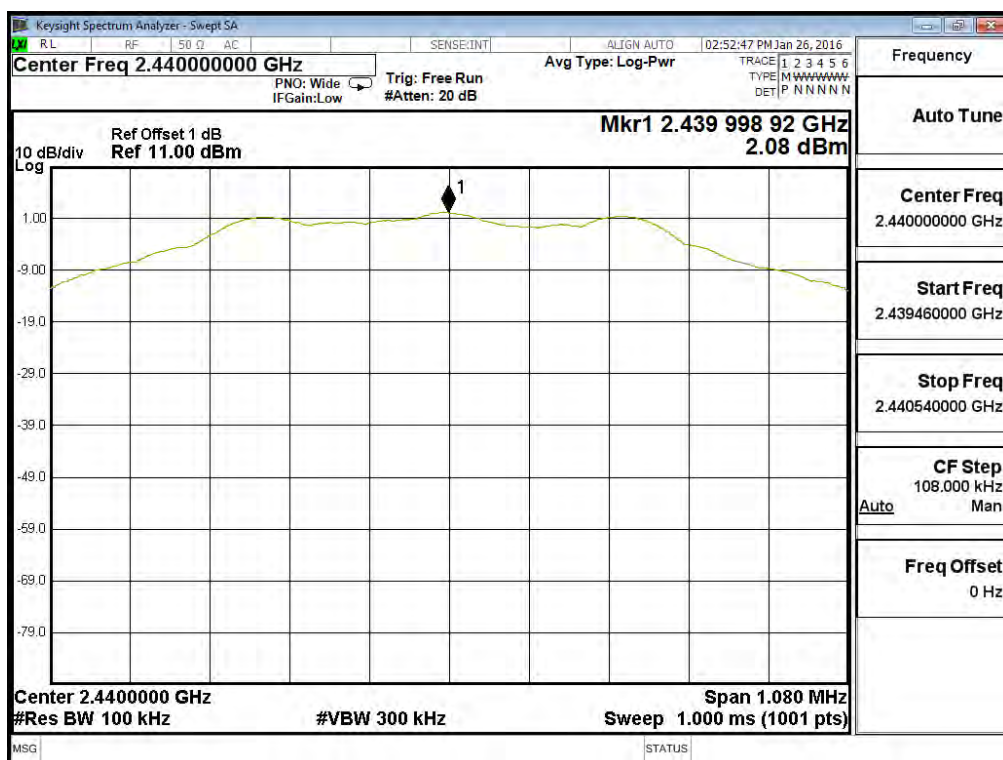

Product : Medical Cart Computer
 Test Item : Power Density Data
 Test Site : No.3 OATS
 Test Mode : Mode 1: Transmit - BLE (GFSK) (2480MHz) (19''+22''+24'')

Channel No.	Frequency (MHz)	Measurement Level (dBm)	Required Limit (dBm)	Result
39	2480	2.100	≤ 8dBm	Pass

Figure Channel 39:

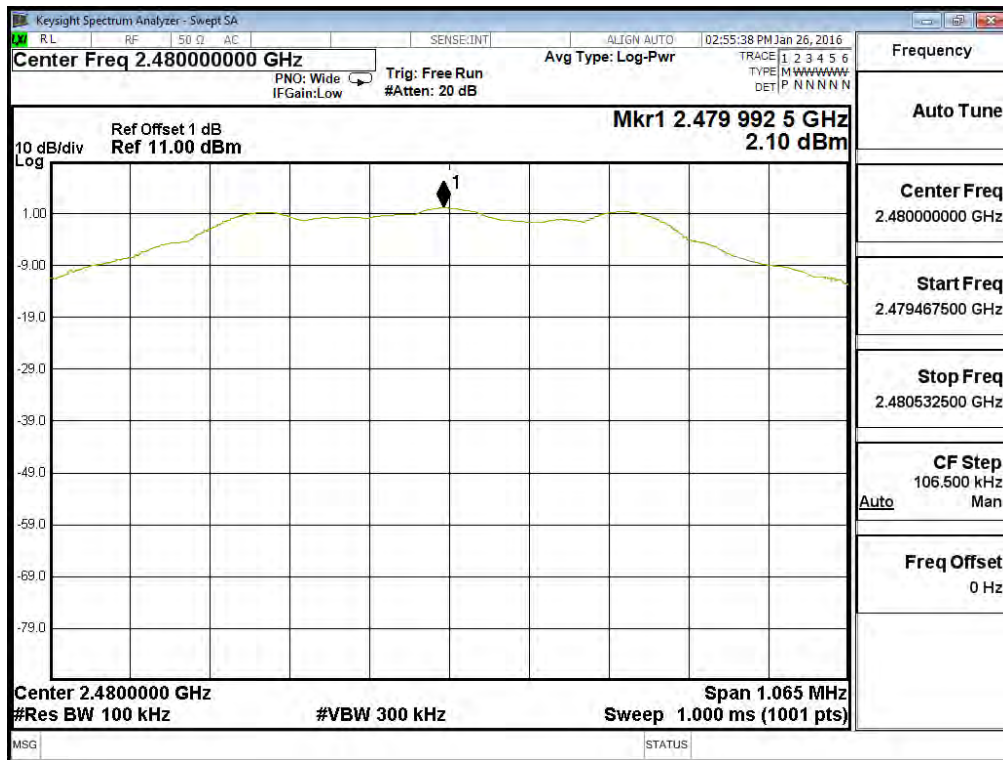

9. EMI Reduction Method During Compliance Testing

No modification was made during testing.