

FCC Test Report

Product Name	Medical Cart Computer
Model No.	DT590B, DT592B, DT594B
FCC ID.	YE3800G

Applicant	DT Research, Inc.
Address	6F, No. 1, NingPo E. St. Taipei, 100 Taiwan

Date of Receipt	Jan. 18, 2016
Issued Date	Mar. 07, 2016
Report No.	1610298R-RFUSP01V00
Report Version	V1.0



The test results relate only to the samples tested.

The test results shown in the test report are traceable to the national/international standard through the calibration report of the equipment and evaluated measurement uncertainty herein.

This report must not be used to claim product endorsement by TAF or any agency of the government.

The test report shall not be reproduced without the written approval of QuieTek Corporation.

Test Report

Issued Date: Mar. 07, 2016

Report No.: 1610298R-RFUSP01V00



Product Name	Medical Cart Computer
Applicant	DT Research, Inc.
Address	6F, No. 1, NingPo E. St. Taipei, 100 Taiwan
Manufacturer	DT Research, Inc.
Model No.	DT590B, DT592B, DT594B
FCC ID.	YE3800G
EUT Rated Voltage	AC 100-240V, 50/60Hz
EUT Test Voltage	AC 120V/60Hz
Trade Name	DT Research, Inc.
Applicable Standard	FCC CFR Title 47 Part 15 Subpart C: 2014 ANSI C63.4: 2014, ANSI C63.10: 2013
Test Result	Complied

Documented By :

Jinn Chen

(Senior Adm. Specialist / Jinn Chen)

Tested By :

Yulin Chen

(Assistant Engineer / Yulin Chen)

Approved By :

Vincent Lin

(Director / Vincent Lin)

TABLE OF CONTENTS

Description	Page
1. GENERAL INFORMATION	5
1.1. EUT Description.....	5
1.2. Operational Description.....	7
1.3. Tested System Details.....	8
1.4. Configuration of Tested System	8
1.5. EUT Exercise Software	10
1.6. Test Facility	11
2. CONDUCTED EMISSION	12
2.1. Test Equipment.....	12
2.2. Test Setup	12
2.3. Limits.....	13
2.4. Test Procedure	13
2.5. Uncertainty	13
2.6. Test Result of Conducted Emission.....	14
3. PEAK POWER OUTPUT	18
3.1. Test Equipment.....	18
3.2. Test Setup	18
3.3. Limit	18
3.4. Test Procedure	18
3.5. Uncertainty	18
3.6. Test Result of Peak Power Output.....	19
4. RADIATED EMISSION	21
4.1. Test Equipment.....	21
4.2. Test Setup	21
4.3. Limits.....	22
4.4. Test Procedure	23
4.5. Uncertainty	23
4.6. Test Result of Radiated Emission.....	24
5. RF ANTENNA CONDUCTED TEST	40
5.1. Test Equipment.....	40
5.2. Test Setup	40
5.3. Limits.....	40
5.4. Test Procedure	40
5.5. Uncertainty	40
5.6. Test Result of RF Antenna Conducted Test.....	41
6. BAND EDGE	43
6.1. Test Equipment.....	43
6.2. Test Setup	43
6.3. Limit	44
6.4. Test Procedure	44
6.5. Uncertainty	44

6.6.	Test Result of Band Edge	45
7.	CHANNEL NUMBER.....	77
7.1.	Test Equipment	77
7.2.	Test Setup	77
7.3.	Limit	77
7.4.	Test Procedure	77
7.5.	Uncertainty	77
7.6.	Test Result of Channel Number.....	78
8.	CHANNEL SEPARATION.....	80
8.1.	Test Equipment	80
8.2.	Test Setup	80
8.3.	Limit	80
8.4.	Test Procedure	80
8.5.	Uncertainty	80
8.6.	Test Result of Channel Separation.....	81
9.	DWELL TIME.....	85
9.1.	Test Equipment	85
9.2.	Test Setup	85
9.3.	Limit	85
9.4.	Test Procedure	85
9.5.	Uncertainty	85
9.6.	Test Result of Dwell Time	86
10.	OCCUPIED BANDWIDTH	90
10.1.	Test Equipment	90
10.2.	Test Setup	90
10.3.	Limits.....	90
10.4.	Test Procedure	90
10.5.	Uncertainty	90
10.6.	Test Result of Occupied Bandwidth	91
11.	EMI REDUCTION METHOD DURING COMPLIANCE TESTING	95

Attachment 1: EUT Test Photographs

Attachment 2: EUT Detailed Photographs

1. GENERAL INFORMATION

1.1. EUT Description

Product Name	Medical Cart Computer
Trade Name	DT Research, Inc.
Model No.	DT590B, DT592B, DT594B
FCC ID.	YE3800G
Frequency Range	2402 – 2480MHz
Channel Number	79
Type of Modulation	FHSS: GFSK(1Mbps) / π /4DQPSK(2Mbps) / 8DPSK(3Mbps)
Antenna Type	PIFA Antenna
Channel Control	Auto
Antenna Gain	Refer to the table “Antenna List”
Power Cable	Non-shielded, 1.8m
Power Adapter	MFR: EDAC, M/N: EM11201D Input: 100-240Vac, 2.0-1.0A, 50-60Hz Output: 18-24V $\overline{\text{---}}$ 120W max Cable Out: Non-shielded, 1.2m, with one ferrite core bonded.

Antenna List

No.	Manufacturer	Part No.	Antenna Type	Peak Gain
1	CUELE	27-594-720020 (210-80012) (Main) 27-594-720010 (210-80013) (Aux)	PIFA Antenna	1.51dBi for 2.4 GHz

Note:

1. The antenna of EUT conforms to FCC 15.203.

Center Frequency of Each Channel:

Channel	Frequency	Channel	Frequency	Channel	Frequency	Channel	Frequency
Channel 00:	2402 MHz	Channel 20:	2422 MHz	Channel 40:	2442 MHz	Channel 60:	2462 MHz
Channel 01:	2403 MHz	Channel 21:	2423 MHz	Channel 41:	2443 MHz	Channel 61:	2463 MHz
Channel 02:	2404 MHz	Channel 22:	2424 MHz	Channel 42:	2444 MHz	Channel 62:	2464 MHz
Channel 03:	2405 MHz	Channel 23:	2425 MHz	Channel 43:	2445 MHz	Channel 63:	2465 MHz
Channel 04:	2406 MHz	Channel 24:	2426 MHz	Channel 44:	2446 MHz	Channel 64:	2466 MHz
Channel 05:	2407 MHz	Channel 25:	2427 MHz	Channel 45:	2447 MHz	Channel 65:	2467 MHz
Channel 06:	2408 MHz	Channel 26:	2428 MHz	Channel 46:	2448 MHz	Channel 66:	2468 MHz
Channel 07:	2409 MHz	Channel 27:	2429 MHz	Channel 47:	2449 MHz	Channel 67:	2469 MHz
Channel 08:	2410 MHz	Channel 28:	2430 MHz	Channel 48:	2450 MHz	Channel 68:	2470 MHz
Channel 09:	2411 MHz	Channel 29:	2431 MHz	Channel 49:	2451 MHz	Channel 69:	2471 MHz
Channel 10:	2412 MHz	Channel 30:	2432 MHz	Channel 50:	2452 MHz	Channel 70:	2472 MHz
Channel 11:	2413 MHz	Channel 31:	2433 MHz	Channel 51:	2453 MHz	Channel 71:	2473 MHz
Channel 12:	2414 MHz	Channel 32:	2434 MHz	Channel 52:	2454 MHz	Channel 72:	2474 MHz
Channel 13:	2415 MHz	Channel 33:	2435 MHz	Channel 53:	2455 MHz	Channel 73:	2475 MHz
Channel 14:	2416 MHz	Channel 34:	2436 MHz	Channel 54:	2456 MHz	Channel 74:	2476 MHz
Channel 15:	2417 MHz	Channel 35:	2437 MHz	Channel 55:	2457 MHz	Channel 75:	2477 MHz
Channel 16:	2418 MHz	Channel 36:	2438 MHz	Channel 56:	2458 MHz	Channel 76:	2478 MHz
Channel 17:	2419 MHz	Channel 37:	2439 MHz	Channel 57:	2459 MHz	Channel 77:	2479 MHz
Channel 18:	2420 MHz	Channel 38:	2440 MHz	Channel 58:	2460 MHz	Channel 78:	2480 MHz
Channel 19:	2421 MHz	Channel 39:	2441 MHz	Channel 59:	2461 MHz		

Note:

1. The EUT is a Medical Cart Computer with a built-in 2.4GHz and 5GHz WLAN 、 Bluetooth transceiver, this report for Bluetooth.
2. These tests were conducted on a sample for the purpose of demonstrating compliance of Bluetooth transmitter with Part 15 Subpart C Paragraph 15.247 for spread spectrum devices.
3. Regarding to the operation frequency, the lowest, middle and highest frequency are selected to perform the test.
4. Bluetooth operation was evaluated at both 1Mb/s and 3Mb/s data rates. 2Mb/s data rate was found, through pre-testing, to produce emissions similar to those for 3Mb/s.
5. Medical Cart Computer operation on 19-inch 、 22-inch and 24-inch size,it was evaluated at both 22-inch and 24-inch size . 22-inch was found through pre-testing, 22-inch produce emissions was worse case.

Test Mode	Mode 1: Transmit - 1Mbps (GFSK) Mode 2: Transmit - 3Mbps (8DPSK)
-----------	---

1.3. Tested System Details

The types for all equipment, plus descriptions of all cables used in the tested system (including inserted cards) are:

For 19”:

	Product	Manufacturer	Model No.	Serial No.	Power Cord
1	LCD Monitor	DELL	ST2320Lf	CN-0M2nn6-72872-22I-C A1S	Non-Shielded, 1.8m
2	LCD Monitor	ASUS	VS229HA	F4LMQS135395	Non-Shielded, 1.8m
3	Modem	ACEEX	DM-1414	0102027541	Non-Shielded, 1.8m
4	Keyboard	Logitech	Y-U0009	LZ027HU	N/A
5	USB Mouse	Logitech	M-U0026	1245HS0684H8	N/A
6	iPod nano	Apple	A1199	5U728909VQ5	N/A
7	iPod nano	Apple	A1199	YM73337PVQ5	N/A
8	iPod nano	Apple	A1199	YM73336EVQ5	N/A
9	iPod nano	Apple	A1199	YM7333DCVQ5	N/A
10	Microphone & Earphone	Ergotech	ET-E201	N/A	N/A

For 22”:

	Product	Manufacturer	Model No.	Serial No.	Power Cord
1	LCD Monitor	DELL	ST2320Lf	CN-0M2nn6-72872-22I-C A1S	Non-Shielded, 1.8m
2	LCD Monitor	ASUS	VS229HA	F4LMQS135395	Non-Shielded, 1.8m
3	Modem	ACEEX	DM-1414	0102027541	Non-Shielded, 1.8m
4	Modem	ACEEX	DM-1414	0102027559	Non-Shielded, 1.8m
5	Modem	ACEEX	DM-1414	0102027533	Non-Shielded, 1.8m
6	Modem	ACEEX	DM-1414	0102027537	Non-Shielded, 1.8m
7	Keyboard	Logitech	Y-U0009	LZ027HU	N/A
8	USB Mouse	Logitech	M-U0026	1245HS0684H8	N/A
9	iPod nano	Apple	A1199	5U728909VQ5	N/A
10	iPod nano	Apple	A1199	YM73337PVQ5	N/A
11	iPod nano	Apple	A1199	YM73336EVQ5	N/A
12	iPod nano	Apple	A1199	YM7333DCVQ5	N/A
13	Microphone & Earphone	Ergotech	ET-E201	N/A	N/A

For 19”:

Signal Cable Type	Signal cable Description
A	HDMI Card Non-Shielded, 1.8m, two PCS.
B	Modem Card Shielded, 1.5m
C	Keyboard Cable Shielded, 1.8m
D	Mouse Cable Shielded, 1.8m
E	USB Cable Shielded, 1.2m, four PCS.
F	Earphone Cable Non-Shielded, 2m

For 22”:

Signal Cable Type	Signal cable Description
A	HDMI Card
B	Modem Card
C	Keyboard Cable
D	Mouse Cable
E	USB Cable
F	Earphone Cable

1.4. Configuration of Tested System

For 19”:

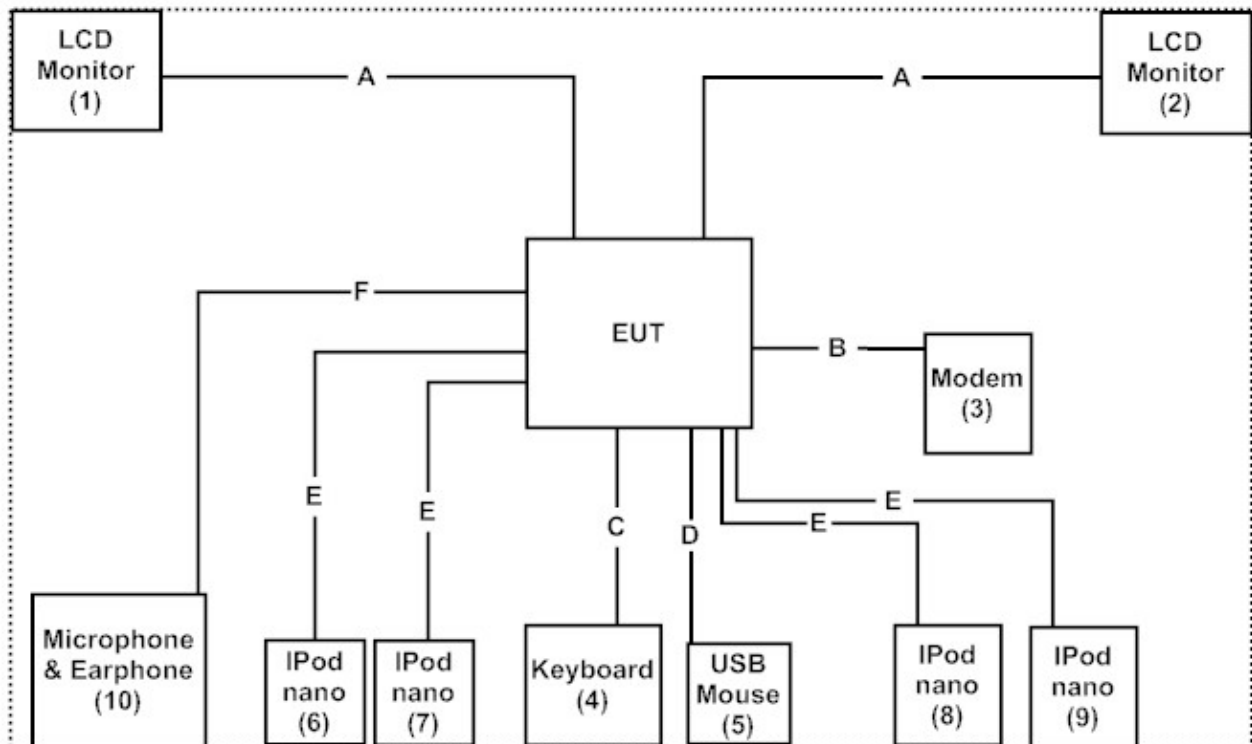

For 22”:

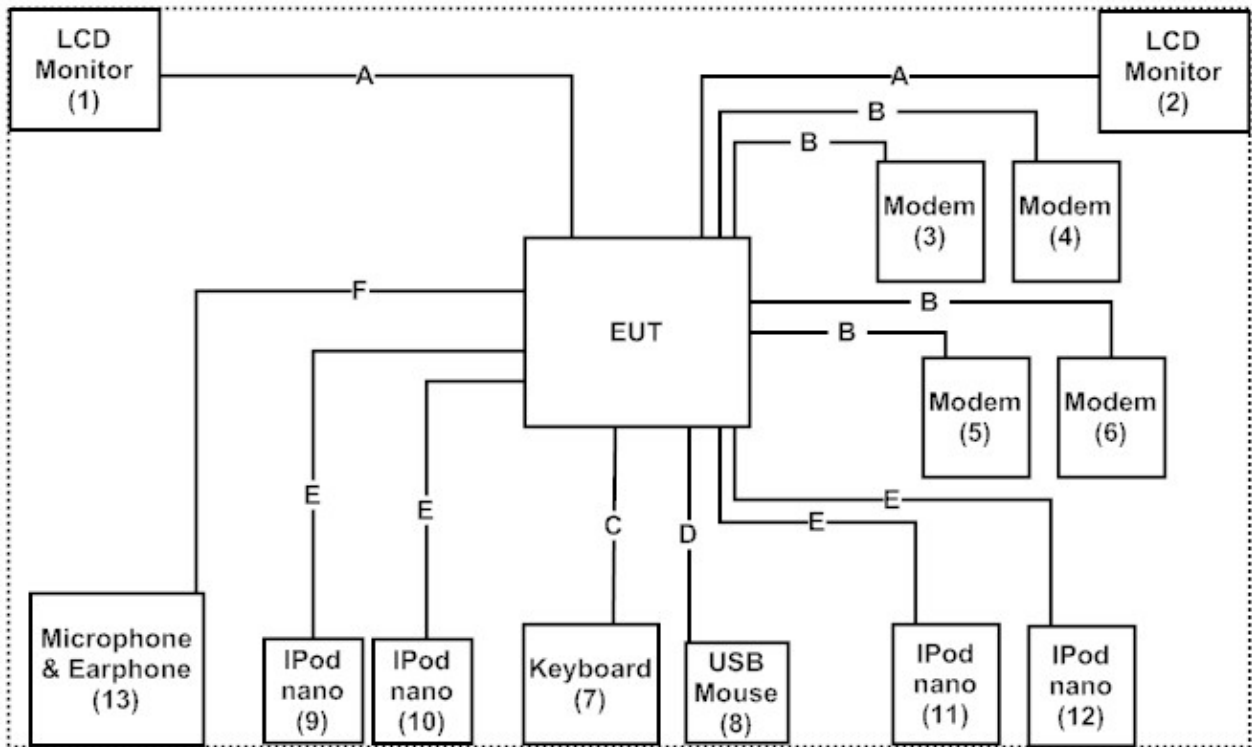

1.5. EUT Exercise Software

1. Setup the EUT as shown in Section 1.4.
2. Execute software “DRTU-V1.7.4-1041” on the EUT.
3. Configure the test mode, the test channel, and the data rate.
4. Press “OK” to start the continuous Transmit.
5. Verify that the EUT works properly.

1.6. Test Facility

Ambient conditions in the laboratory:

Items	Required (IEC 68-1)	Actual
Temperature (°C)	15-35	20-35
Humidity (%RH)	25-75	30-65
Barometric pressure (mbar)	860-1060	950-1000

The related certificate for our laboratories about the test site and management system can be downloaded from Quietek Corporation's Web Site: <http://www.quietek.com/chinese/about/certificates.aspx?bval=5>
 The address and introduction of Quietek Corporation's laboratories can be founded in our Web site: <http://www.quietek.com/>

Site Description: File on
 Federal Communications Commission
 FCC Engineering Laboratory
 7435 Oakland Mills Road
 Columbia, MD 21046
 Registration Number: 92195

Site Name: Quietek Corporation
 Site Address: No.5-22, Ruishukeng,
 Linkou Dist. New Taipei City 24451,
 Taiwan, R.O.C.
 TEL: 886-2-8601-3788 / FAX : 886-2-8601-3789
 E-Mail : service@quietek.com

FCC Accreditation Number: TW1014

2. Conducted Emission

2.1. Test Equipment

	Equipment	Manufacturer	Model No. / Serial No.	Last Cal.	Remark
X	Test Receiver	R & S	ESCS 30 / 825442/018	Sep., 2015	
X	Artificial Mains Network	R & S	ENV4200 / 848411/10	Feb., 2016	Peripherals
X	LISN	R & S	ESH3-Z5 / 825562/002	Feb., 2016	EUT
	DC LISN	Schwarzbeck	8226 / 176	Mar., 2016	EUT
X	Pulse Limiter	R & S	ESH3-Z2 / 357.8810.52	Feb., 2016	
	No.1 Shielded Room				

Note:

1. All equipments are calibrated every one year.
2. The test instruments marked by “X” are used to measure the final test results.

2.2. Test Setup

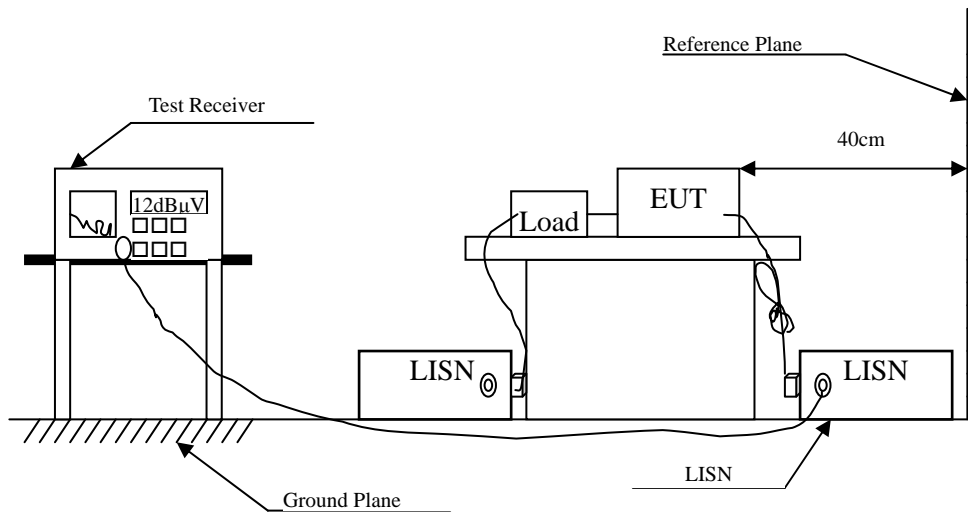

2.3. Limits

FCC Part 15 Subpart C Paragraph 15.207 (dBµV) Limit		
Frequency MHz	Limits	
	QP	AV
0.15 - 0.50	66-56	56-46
0.50-5.0	56	46
5.0 - 30	60	50

Remarks: In the above table, the tighter limit applies at the band edges.

2.4. Test Procedure

The EUT and Peripherals are connected to the main power through a line impedance stabilization network (L.I.S.N.). This provides a 50 ohm /50uH coupling impedance for the measuring equipment. The peripheral devices are also connected to the main power through a LISN that provides a 50ohm /50uH coupling impedance with 50ohm termination. (Please refer to the block diagram of the test setup and photographs.)

Both sides of A.C. line are checked for maximum conducted interference. In order to find the maximum emission, the relative positions of equipment and all the interface cables must be changed according to ANSI C63.4: 2014 on conducted measurement.

Conducted emissions were investigated over the frequency range from 0.15MHz to 30MHz using a receiver bandwidth of 9kHz.

The EUT was setup to ANSI C63.4, 2014; tested to FHSS test procedure of FCC Public Notice DA 00-705 for compliance to FCC 47CFR 15.247 requirements.

2.5. Uncertainty

± 2.26 dB

2.6. Test Result of Conducted Emission

Product : Medical Cart Computer
Test Item : Conducted Emission Test
Power Line : Line 1
Test Mode : Mode 2: Transmit - 3Mbps (8DPSK) (2441MHz) (19")

Frequency MHz	Correct Factor dB	Reading Level dBµV	Measurement Level dBµV	Margin dB	Limit dBµV
LINE 1					
Quasi-Peak					
0.154	9.783	17.440	27.223	-38.663	65.886
0.267	9.780	3.750	13.530	-49.127	62.657
0.548	9.792	13.190	22.982	-33.018	56.000
0.615	9.797	17.180	26.977	-29.023	56.000
6.716	10.041	2.250	12.291	-47.709	60.000
14.427	10.147	17.950	28.097	-31.903	60.000
Average					
0.154	9.783	13.000	22.783	-33.103	55.886
0.267	9.780	0.240	10.020	-42.637	52.657
0.548	9.792	9.720	19.512	-26.488	46.000
0.615	9.797	11.580	21.377	-24.623	46.000
6.716	10.041	-1.610	8.431	-41.569	50.000
14.427	10.147	13.080	23.227	-26.773	50.000

Note:

1. All Reading Levels are Quasi-Peak and average value.
2. "■" means the worst emission level.
3. Measurement Level = Reading Level + Correct Factor

Product : Medical Cart Computer
Test Item : Conducted Emission Test
Power Line : Line 2
Test Mode : Mode 2: Transmit - 3Mbps (8DPSK) (2441MHz) (19")

Frequency MHz	Correct Factor dB	Reading Level dBμV	Measurement Level dBμV	Margin dB	Limit dBμV
LINE 2					
Quasi-Peak					
0.162	9.832	15.890	25.722	-39.935	65.657
0.209	9.835	12.350	22.185	-42.129	64.314
0.615	9.867	17.220	27.087	-28.913	56.000
1.107	9.905	1.120	11.025	-44.975	56.000
4.607	10.073	1.330	11.403	-44.597	56.000
13.576	10.255	16.520	26.775	-33.225	60.000
Average					
0.162	9.832	1.480	11.312	-44.345	55.657
0.209	9.835	7.830	17.665	-36.649	54.314
0.615	9.867	10.640	20.507	-25.493	46.000
1.107	9.905	-2.180	7.725	-38.275	46.000
4.607	10.073	-1.830	8.243	-37.757	46.000
13.576	10.255	11.970	22.225	-27.775	50.000

Note:

1. All Reading Levels are Quasi-Peak and average value.
2. "█" means the worst emission level.
3. Measurement Level = Reading Level + Correct Factor

Product : Medical Cart Computer
Test Item : Conducted Emission Test
Power Line : Line 1
Test Mode : Mode 2: Transmit - 3Mbps (8DPSK) (2441MHz) (22")

Frequency MHz	Correct Factor dB	Reading Level dBμV	Measurement Level dBμV	Margin dB	Limit dBμV
LINE 1					
Quasi-Peak					
0.154	9.783	44.710	54.493	-11.393	65.886
0.224	9.777	37.020	46.797	-17.089	63.886
0.341	9.776	26.390	36.166	-24.377	60.543
0.439	9.783	18.220	28.003	-29.740	57.743
3.162	9.967	6.330	16.297	-39.703	56.000
13.966	10.140	32.120	42.260	-17.740	60.000
Average					
0.154	9.783	26.420	36.203	-19.683	55.886
0.224	9.777	24.700	34.477	-19.409	53.886
0.341	9.776	8.160	17.936	-32.607	50.543
0.439	9.783	7.410	17.193	-30.550	47.743
3.162	9.967	-0.720	9.247	-36.753	46.000
13.966	10.140	27.780	37.920	-12.080	50.000

Note:

1. All Reading Levels are Quasi-Peak and average value.
2. "■" means the worst emission level.
3. Measurement Level = Reading Level + Correct Factor

Product : Medical Cart Computer
Test Item : Conducted Emission Test
Power Line : Line 2
Test Mode : Mode 2: Transmit - 3Mbps (8DPSK) (2441MHz) (22")

Frequency MHz	Correct Factor dB	Reading Level dBµV	Measurement Level dBµV	Margin dB	Limit dBµV
LINE 2					
Quasi-Peak					
0.166	9.832	43.240	53.072	-12.471	65.543
0.193	9.834	36.110	45.944	-18.827	64.771
0.244	9.838	22.870	32.708	-30.606	63.314
0.338	9.845	18.280	28.125	-32.504	60.629
0.716	9.875	10.110	19.985	-36.015	56.000
14.142	10.273	33.040	43.313	-16.687	60.000
Average					
0.166	9.832	14.340	24.172	-31.371	55.543
0.193	9.834	22.890	32.724	-22.047	54.771
0.244	9.838	15.040	24.878	-28.436	53.314
0.338	9.845	12.350	22.195	-28.434	50.629
0.716	9.875	5.940	15.815	-30.185	46.000
14.142	10.273	29.540	39.813	-10.187	50.000

Note:

1. All Reading Levels are Quasi-Peak and average value.
2. "█" means the worst emission level.
3. Measurement Level = Reading Level + Correct Factor

3. Peak Power Output

3.1. Test Equipment

	Equipment	Manufacturer	Model No./Serial No.	Last Cal.
X	Power Meter	Anritsu	ML2495A/6K00003357	May, 2015
X	Power Sensor	Anritsu	MA2411B/0738448	Jun., 2015

Note: 1. All equipments are calibrated every one year.
2. The test instruments marked by “X” are used to measure the final test results.

3.2. Test Setup

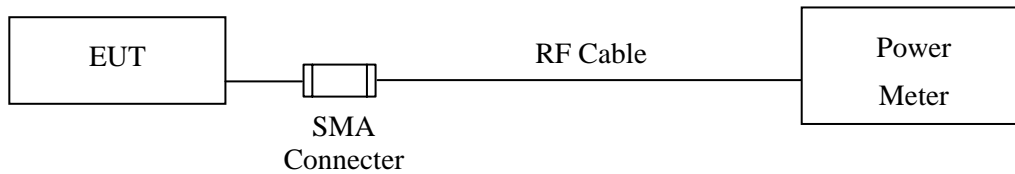

3.3. Limit

The maximum peak power shall be less 1Watt.

3.4. Test Procedure

The EUT was setup to ANSI C63.4, 2014; tested to FHSS test procedure of FCC Public Notice DA 00-705 for compliance to FCC 47CFR 15.247 requirements.

3.5. Uncertainty

± 1.27 dB

3.6. Test Result of Peak Power Output

Product : Medical Cart Computer
Test Item : Peak Power Output
Test Site : No.3 OATS
Test Mode : Mode 1: Transmit - 1Mbps (GFSK) (19''+22''+24'')

Channel No.	Frequency (MHz)	Measurement (dBm)	Required Limit	Result
Channel 00	2402.00	1.27	1 Watt= 30 dBm	Pass
Channel 39	2441.00	2.17	1 Watt= 30 dBm	Pass
Channel 78	2480.00	2.48	1 Watt= 30 dBm	Pass

Product : Medical Cart Computer
 Test Item : Peak Power Output
 Test Site : No.3 OATS
 Test Mode : Mode 2: Transmit - 3Mbps (8DPSK) (19''+22''+24'')

Channel No.	Frequency (MHz)	Measurement (dBm)	Required Limit	Result
Channel 00	2402.00	-0.65	1 Watt= 30 dBm	Pass
Channel 39	2441.00	0.24	1 Watt= 30 dBm	Pass
Channel 78	2480.00	0.56	1 Watt= 30 dBm	Pass

4. Radiated Emission

4.1. Test Equipment

The following test equipments are used during the radiated emission test:

Test Site	Equipment	Manufacturer	Model No./Serial No.	Last Cal.	
☒ Site # 3	X	Magnetic Loop Antenna	Teseq	HLA6121/ 37133	Sep, 2015
	X	Bilog Antenna	Schaffner Chase	CBL6112B/ 2707	Jun., 2015
	X	EMI Test Receiver	R&S	ESCS 30/838251/ 001	Jun., 2015
	X	Coaxial Cable	QTK(Arnist)	RG 214/ LC003-RG	Jun., 2015
	X	Coaxial signal switch	Arnist	MP59B/ 6200798682	Jun., 2015

Test Site	Equipment	Manufacturer	Model No./Serial No.	Last Cal.	
☒ CB # 8	X	Spectrum Analyzer	R&S	FSP40/ 100339	Oct., 2015
	X	Horn Antenna	ETS-Lindgren	3117/ 35205	Mar., 2016
	X	Horn Antenna	Schwarzbeck	BBHA9170/209	Jan., 2016
	X	Horn Antenna	TRC	AH-0801/95051	Aug., 2015
	X	Pre-Amplifier	EMCI	EMC012630SE/980210	Jan., 2016
	X	Pre-Amplifier	MITEQ	JS41-001040000-58-5P/153945	Jul., 2015
	X	Pre-Amplifier	NARDA	DBL-1840N506/013	Jul., 2015

- Note: 1. All equipments are calibrated with traceable calibrations. Each calibration is traceable to the national or international standards.
2. The test instruments marked with “X” are used to measure the final test results.

4.2. Test Setup

sBelow 1GHz

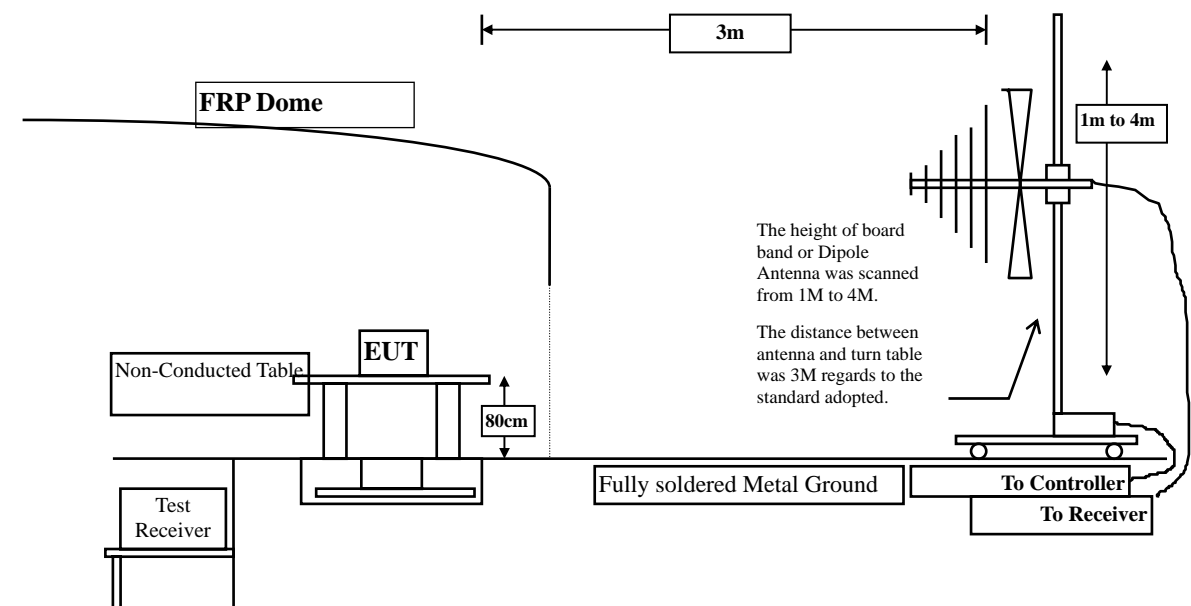

Above 1GHz

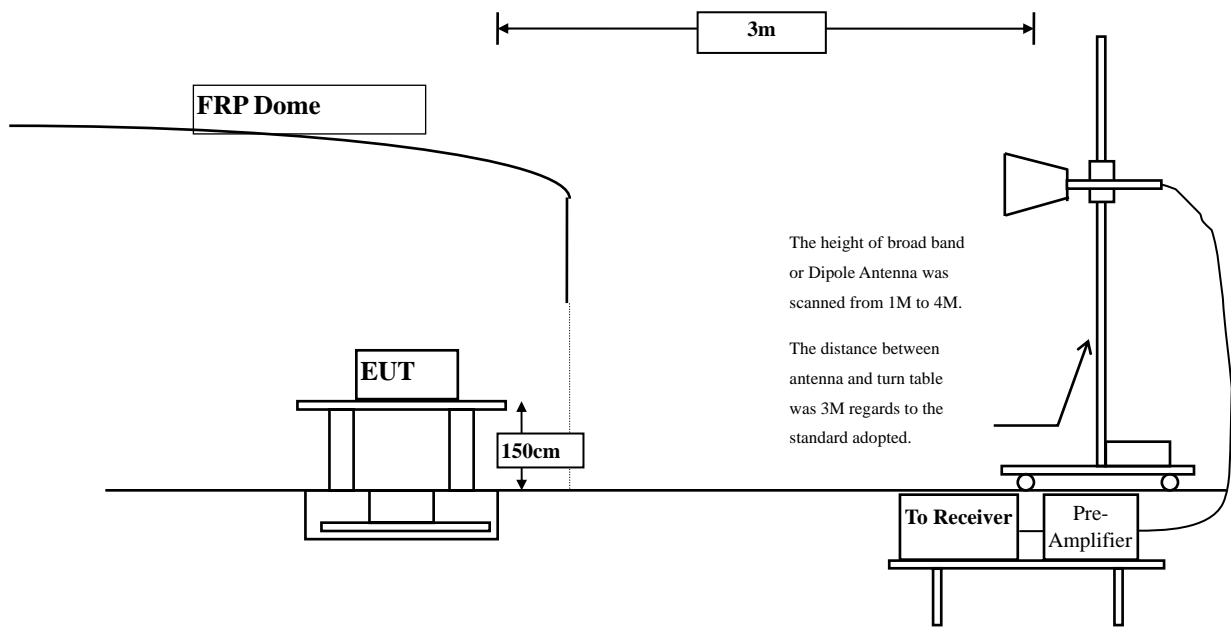

4.3. Limits

➤ General Radiated Emission Limits

Emissions radiated outside of the specified frequency bands, except for harmonics, shall be attenuated by at least 20dB below the level of the fundamental or to the general radiated emission limits in paragraph 15.209, whichever is the lesser attenuation.

FCC Part 15 Subpart C Paragraph 15.209 Limits		
Frequency MHz	uV/m @3m	dBμV/m@3m
30-88	100	40
88-216	150	43.5
216-960	200	46
Above 960	500	54

- Remarks:
1. RF Voltage (dBμV) = 20 log RF Voltage (uV)
 2. In the Above Table, the tighter limit applies at the band edges.
 3. Distance refers to the distance in meters between the measuring instrument antenna and the closed point of any part of the device or system.

4.4. Test Procedure

The EUT was setup according to ANSI C63.10, 2013 and tested compliance to FCC 47CFR 15.249 requirements.

Measuring the frequency range below 1GHz, the EUT is placed on a turn table which is 0.8 meter above ground, when measuring the frequency range above 1GHz, the EUT is placed on a turn table which is 1.5 meter above ground.

The turn table is rotated 360 degrees to determine the position of the maximum emission level.

The EUT was positioned such that the distance from antenna to the EUT was 3 meters.

The antenna is scanned between 1 meter and 4 meters to find out the maximum emission level. This is repeated for both horizontal and vertical polarization of the antenna. In order to find the maximum emission, all of the interface cables were manipulated according to ANSI C63.10: 2013 on radiated measurement.

The resolution bandwidth below 30MHz setting on the field strength meter is 9kHz and 30MHz~1GHz is 120kHz and above 1GHz is 1MHz.

Radiated emission measurements below 30MHz are made using Loop Antenna and 30MHz~1GHz are made using broadband Bilog antenna and above 1GHz are made using Horn Antennas.

The measurement is divided into the Preliminary Measurement and the Final Measurement.

The suspected frequencies are searched for in Preliminary Measurement with the measurement antenna kept pointed at the source of the emission both in azimuth and elevation, with the polarization of the antenna oriented for maximum response. The antenna is pointed at an angle towards the source of the emission, and the EUT is rotated in both height and polarization to maximize the measured emission. The emission is kept within the illumination area of the 3 dB bandwidth of the antenna.

The worst radiated emission is measured in the Open Area Test Site on the Final Measurement.

The measurement frequency range from 9kHz - 10th Harmonic of fundamental was investigated.

4.5. Uncertainty

± 3.9 dB above 1GHz

± 3.8 dB below 1GHz

4.6. Test Result of Radiated Emission

Product : Medical Cart Computer
 Test Item : Harmonic Radiated Emission
 Test Site : No.3 OATS
 Test Mode : Mode 1: Transmit - 1Mbps (GFSK)(2402MHz) (19'')

Frequency MHz	Correct Factor dB	Reading Level dBµV	Measurement Level dBµV/m	Margin dB	Limit dBµV/m
Horizontal					
Peak Detector:					
4804.000	3.327	43.393	46.720	-27.280	74.000
7206.000	10.136	38.145	48.281	-25.719	74.000
9608.000	13.706	35.748	49.454	-24.546	74.000
Average Detector:					
--					
Vertical					
Peak Detector:					
4804.000	6.638	47.245	53.882	-20.118	74.000
7206.000	11.005	37.354	48.359	-25.641	74.000
9608.000	14.103	25.027	39.130	-34.870	74.000
Average Detector:					
--					

Note:

1. All Readings below 1GHz are Quasi-Peak, above 1GHz are performed with peak and/or average measurements as necessary.
2. Peak measurements: RBW = 1MHz, VBW = 3 MHz, Sweep: Auto.
3. Average measurements: RBW = 1MHz, VBW = 10 Hz, Sweep: Auto.
4. Measurement Level = Reading Level + Correct Factor.
5. Correct Factor = Antenna factor + Cable loss – Amplifier gain.
6. The average measurement was not performed when the peak measured data under the limit of average detection.
7. The emission levels of other frequencies are very lower than the limit and not show in test report.

Product : Medical Cart Computer
Test Item : Harmonic Radiated Emission
Test Site : No.3 OATS
Test Mode : Mode 1: Transmit - 1Mbps (GFSK)(2441MHz) (19'')

Frequency MHz	Correct Factor dB	Reading Level dB μ V	Measurement Level dB μ V/m	Margin dB	Limit dB μ V/m
Horizontal					
Peak Detector:					
4882.000	3.001	43.074	46.075	-27.925	74.000
7323.000	11.846	35.894	47.741	-26.259	74.000
9764.000	12.563	35.258	47.821	-26.179	74.000
Average Detector:					
--					
Vertical					
Peak Detector:					
4882.000	5.713	36.196	41.910	-32.090	74.000
7323.000	12.727	35.176	47.904	-26.096	74.000
9764.000	13.028	35.647	48.675	-25.325	74.000
Average Detector:					
--					

Note:

1. All Readings below 1GHz are Quasi-Peak, above 1GHz are performed with peak and/or average measurements as necessary.
2. Peak measurements: RBW = 1MHz, VBW = 3 MHz, Sweep: Auto.
3. Average measurements: RBW = 1MHz, VBW = 10 Hz, Sweep: Auto.
4. Measurement Level = Reading Level + Correct Factor.
5. Correct Factor = Antenna factor + Cable loss – Amplifier gain.
6. The average measurement was not performed when the peak measured data under the limit of average detection.
7. The emission levels of other frequencies are very lower than the limit and not show in test report.

Product : Medical Cart Computer
 Test Item : Harmonic Radiated Emission
 Test Site : No.3 OATS
 Test Mode : Mode 1: Transmit - 1Mbps (GFSK)(2480MHz) (19'')

Frequency MHz	Correct Factor dB	Reading Level dB μ V	Measurement Level dB μ V/m	Margin dB	Limit dB μ V/m
Horizontal					
Peak Detector:					
4960.000	2.760	45.682	48.442	-25.558	74.000
7440.000	12.567	35.179	47.745	-26.255	74.000
9920.000	13.456	35.460	48.916	-25.084	74.000
Average Detector:					
--					
Vertical					
Peak Detector:					
4960.000	5.557	42.342	47.899	-26.101	74.000
7440.000	13.426	35.429	48.854	-25.146	74.000
9920.000	13.958	35.627	49.585	-24.415	74.000
Average Detector:					
--					

Note:

1. All Readings below 1GHz are Quasi-Peak, above 1GHz are performed with peak and/or average measurements as necessary.
2. Peak measurements: RBW = 1MHz, VBW = 3 MHz, Sweep: Auto.
3. Average measurements: RBW = 1MHz, VBW = 10 Hz, Sweep: Auto.
4. Measurement Level = Reading Level + Correct Factor.
5. Correct Factor = Antenna factor + Cable loss – Amplifier gain.
6. The average measurement was not performed when the peak measured data under the limit of average detection.
7. The emission levels of other frequencies are very lower than the limit and not show in test report.

Product : Medical Cart Computer
 Test Item : Harmonic Radiated Emission
 Test Site : No.3 OATS
 Test Mode : Mode 2: Transmit - 3Mbps (8DPSK)(2402MHz) (19'')

Frequency MHz	Correct Factor dB	Reading Level dB μ V	Measurement Level dB μ V/m	Margin dB	Limit dB μ V/m
Horizontal					
Peak Detector:					
4804.000	3.327	44.143	47.470	-26.530	74.000
7206.000	10.136	38.495	48.631	-25.369	74.000
9608.000	13.706	35.228	48.934	-25.066	74.000
Average Detector:					
--					
Vertical					
Peak Detector:					
4804.000	6.638	46.135	52.772	-21.228	74.000
7206.000	11.005	37.364	48.369	-25.631	74.000
9608.000	14.103	35.234	49.337	-24.663	74.000
Average Detector:					
--					

Note:

1. All Readings below 1GHz are Quasi-Peak, above 1GHz are performed with peak and/or average measurements as necessary.
2. Peak measurements: RBW = 1MHz, VBW = 3 MHz, Sweep: Auto.
3. Average measurements: RBW = 1MHz, VBW = 10 Hz, Sweep: Auto.
4. Measurement Level = Reading Level + Correct Factor.
5. Correct Factor = Antenna factor + Cable loss – Amplifier gain.
6. The average measurement was not performed when the peak measured data under the limit of average detection.
7. The emission levels of other frequencies are very lower than the limit and not show in test report.

Product : Medical Cart Computer
 Test Item : Harmonic Radiated Emission
 Test Site : No.3 OATS
 Test Mode : Mode 2: Transmit - 3Mbps (8DPSK) (2441MHz) (19")

Frequency MHz	Correct Factor dB	Reading Level dBμV	Measurement Level dBμV/m	Margin dB	Limit dBμV/m
Horizontal					
Peak Detector:					
4882.000	3.001	41.504	44.505	-29.495	74.000
7323.000	11.846	35.754	47.601	-26.399	74.000
9764.000	12.563	35.488	48.051	-25.949	74.000
Average Detector:					
--					
Vertical					
Peak Detector:					
4882.000	5.713	37.794	43.508	-30.492	74.000
7323.000	12.727	35.446	48.174	-25.826	74.000
9764.000	13.028	35.287	48.315	-25.685	74.000
Average Detector:					
--					

Note:

1. All Readings below 1GHz are Quasi-Peak, above 1GHz are performed with peak and/or average measurements as necessary.
2. Peak measurements: RBW = 1MHz, VBW = 3 MHz, Sweep: Auto.
3. Average measurements: RBW = 1MHz, VBW = 10 Hz, Sweep: Auto.
4. Measurement Level = Reading Level + Correct Factor.
5. Correct Factor = Antenna factor + Cable loss – Amplifier gain.
6. The average measurement was not performed when the peak measured data under the limit of average detection.
7. The emission levels of other frequencies are very lower than the limit and not show in test report.

Product : Medical Cart Computer
Test Item : Harmonic Radiated Emission
Test Site : No.3 OATS
Test Mode : Mode 2: Transmit - 3Mbps (8DPSK) (2480MHz) (19")

Frequency MHz	Correct Factor dB	Reading Level dB μ V	Measurement Level dB μ V/m	Margin dB	Limit dB μ V/m
Horizontal					
Peak Detector:					
4960.000	2.760	44.182	46.942	-27.058	74.000
7440.000	12.567	35.529	48.095	-25.905	74.000
9920.000	13.456	34.680	48.136	-25.864	74.000
Average Detector:					
--					
Vertical					
Peak Detector:					
4960.000	5.557	44.612	50.169	-23.831	74.000
7440.000	13.426	35.689	49.114	-24.886	74.000
9920.000	13.958	35.337	49.295	-24.705	74.000
Average Detector:					
--					

Note:

1. All Readings below 1GHz are Quasi-Peak, above 1GHz are performed with peak and/or average measurements as necessary.
2. Peak measurements: RBW = 1MHz, VBW = 3 MHz, Sweep: Auto.
3. Average measurements: RBW = 1MHz, VBW = 10 Hz, Sweep: Auto.
4. Measurement Level = Reading Level + Correct Factor.
5. Correct Factor = Antenna factor + Cable loss –Amplifier gain.
6. The average measurement was not performed when the peak measured data under the limit of average detection.
7. The emission levels of other frequencies are very lower than the limit and not show in test report.

Product : Medical Cart Computer
Test Item : Harmonic Radiated Emission
Test Site : No.3 OATS
Test Mode : Mode 1: Transmit - 1Mbps (GFSK)(2402MHz) (22'')

Frequency MHz	Correct Factor dB	Reading Level dB μ V	Measurement Level dB μ V/m	Margin dB	Limit dB μ V/m
Horizontal					
Peak Detector:					
4804.000	3.327	35.570	38.897	-35.103	74.000
7206.000	10.136	30.470	40.606	-33.394	74.000
9608.000	13.706	30.860	44.566	-29.434	74.000
Average Detector:					
--					
Vertical					
Peak Detector:					
4804.000	6.638	36.760	43.397	-30.603	74.000
7206.000	11.005	30.090	41.095	-32.905	74.000
9608.000	14.103	30.790	44.893	-29.107	74.000
Average Detector:					
--					

Note:

1. All Readings below 1GHz are Quasi-Peak, above 1GHz are performed with peak and/or average measurements as necessary.
2. Peak measurements: RBW = 1MHz, VBW = 3 MHz, Sweep: Auto.
3. Average measurements: RBW = 1MHz, VBW = 10 Hz, Sweep: Auto.
4. Measurement Level = Reading Level + Correct Factor.
5. Correct Factor = Antenna factor + Cable loss – Amplifier gain.
6. The average measurement was not performed when the peak measured data under the limit of average detection.
7. The emission levels of other frequencies are very lower than the limit and not show in test report.

Product : Medical Cart Computer
Test Item : Harmonic Radiated Emission
Test Site : No.3 OATS
Test Mode : Mode 1: Transmit - 1Mbps (GFSK)(2441MHz) (22")

Frequency MHz	Correct Factor dB	Reading Level dB μ V	Measurement Level dB μ V/m	Margin dB	Limit dB μ V/m
Horizontal					
Peak Detector:					
4882.000	3.001	35.900	38.901	-35.099	74.000
7323.000	11.846	31.200	43.047	-30.953	74.000
9764.000	12.563	30.590	43.153	-30.847	74.000
Average Detector:					
--					
Vertical					
Peak Detector:					
4882.000	5.713	35.040	40.754	-33.246	74.000
7323.000	12.727	30.660	43.388	-30.612	74.000
9764.000	13.028	30.730	43.758	-30.242	74.000
Average Detector:					
--					

Note:

1. All Readings below 1GHz are Quasi-Peak, above 1GHz are performed with peak and/or average measurements as necessary.
2. Peak measurements: RBW = 1MHz, VBW = 3 MHz, Sweep: Auto.
3. Average measurements: RBW = 1MHz, VBW = 10 Hz, Sweep: Auto.
4. Measurement Level = Reading Level + Correct Factor.
5. Correct Factor = Antenna factor + Cable loss – Amplifier gain.
6. The average measurement was not performed when the peak measured data under the limit of average detection.
7. The emission levels of other frequencies are very lower than the limit and not show in test report.

Product : Medical Cart Computer
Test Item : Harmonic Radiated Emission
Test Site : No.3 OATS
Test Mode : Mode 1: Transmit - 1Mbps (GFSK)(2480MHz) (22'')

Frequency MHz	Correct Factor dB	Reading Level dB μ V	Measurement Level dB μ V/m	Margin dB	Limit dB μ V/m
Horizontal					
Peak Detector:					
4960.000	2.760	34.170	36.930	-37.070	74.000
7440.000	12.567	31.180	43.746	-30.254	74.000
9920.000	13.456	32.210	45.666	-28.334	74.000
Average Detector:					
--					
Vertical					
Peak Detector:					
4960.000	5.557	35.070	40.627	-33.373	74.000
7440.000	13.426	31.680	45.105	-28.895	74.000
9920.000	13.958	32.390	46.348	-27.652	74.000
Average Detector:					
--					

Note:

1. All Readings below 1GHz are Quasi-Peak, above 1GHz are performed with peak and/or average measurements as necessary.
2. Peak measurements: RBW = 1MHz, VBW = 3 MHz, Sweep: Auto.
3. Average measurements: RBW = 1MHz, VBW = 10 Hz, Sweep: Auto.
4. Measurement Level = Reading Level + Correct Factor.
5. Correct Factor = Antenna factor + Cable loss – Amplifier gain.
6. The average measurement was not performed when the peak measured data under the limit of average detection.
7. The emission levels of other frequencies are very lower than the limit and not show in test report.

Product : Medical Cart Computer
 Test Item : Harmonic Radiated Emission
 Test Site : No.3 OATS
 Test Mode : Mode 2: Transmit - 3Mbps (8DPSK)(2402MHz) (22'')

Frequency MHz	Correct Factor dB	Reading Level dBμV	Measurement Level dBμV/m	Margin dB	Limit dBμV/m
Horizontal					
Peak Detector:					
4804.000	3.327	34.240	37.567	-36.433	74.000
7206.000	10.136	31.250	41.386	-32.614	74.000
9608.000	13.706	31.350	45.056	-28.944	74.000
Average Detector:					
--					
Vertical					
Peak Detector:					
4804.000	6.638	34.300	40.937	-33.063	74.000
7206.000	11.005	30.640	41.645	-32.355	74.000
9608.000	14.103	31.650	45.753	-28.247	74.000
Average Detector:					
--					

Note:

1. All Readings below 1GHz are Quasi-Peak, above 1GHz are performed with peak and/or average measurements as necessary.
2. Peak measurements: RBW = 1MHz, VBW = 3 MHz, Sweep: Auto.
3. Average measurements: RBW = 1MHz, VBW = 10 Hz, Sweep: Auto.
4. Measurement Level = Reading Level + Correct Factor.
5. Correct Factor = Antenna factor + Cable loss – Amplifier gain.
6. The average measurement was not performed when the peak measured data under the limit of average detection.
7. The emission levels of other frequencies are very lower than the limit and not show in test report.

Product : Medical Cart Computer
 Test Item : Harmonic Radiated Emission
 Test Site : No.3 OATS
 Test Mode : Mode 2: Transmit - 3Mbps (8DPSK) (2441MHz) (22'')

Frequency MHz	Correct Factor dB	Reading Level dBμV	Measurement Level dBμV/m	Margin dB	Limit dBμV/m
------------------	-------------------------	--------------------------	--------------------------------	--------------	-----------------

Horizontal

Peak Detector:

4882.000	3.001	34.210	37.211	-36.789	74.000
7323.000	11.846	31.550	43.397	-30.603	74.000
9764.000	12.563	31.300	43.863	-30.137	74.000

Average

Detector:

--

Vertical

Peak Detector:

4882.000	5.713	35.500	41.214	-32.786	74.000
7323.000	12.727	31.170	43.898	-30.102	74.000
9764.000	13.028	31.510	44.538	-29.462	74.000

Average

Detector:

--

Note:

1. All Readings below 1GHz are Quasi-Peak, above 1GHz are performed with peak and/or average measurements as necessary.
2. Peak measurements: RBW = 1MHz, VBW = 3 MHz, Sweep: Auto.
3. Average measurements: RBW = 1MHz, VBW = 10 Hz, Sweep: Auto.
4. Measurement Level = Reading Level + Correct Factor.
5. Correct Factor = Antenna factor + Cable loss – Amplifier gain.
6. The average measurement was not performed when the peak measured data under the limit of average detection.
7. The emission levels of other frequencies are very lower than the limit and not show in test report.

Product : Medical Cart Computer
Test Item : Harmonic Radiated Emission
Test Site : No.3 OATS
Test Mode : Mode 2: Transmit - 3Mbps (8DPSK) (2480MHz) (22")

Frequency MHz	Correct Factor dB	Reading Level dB μ V	Measurement Level dB μ V/m	Margin dB	Limit dB μ V/m
Horizontal					
Peak Detector:					
4960.000	2.760	35.110	37.870	-36.130	74.000
7440.000	12.567	32.270	44.836	-29.164	74.000
9920.000	13.456	32.520	45.976	-28.024	74.000
Average Detector:					
--					
Vertical					
Peak Detector:					
4960.000	5.557	34.140	39.697	-34.303	74.000
7440.000	13.426	31.650	45.075	-28.925	74.000
9920.000	13.958	32.290	46.248	-27.752	74.000
Average Detector:					
--					

Note:

1. All Readings below 1GHz are Quasi-Peak, above 1GHz are performed with peak and/or average measurements as necessary.
2. Peak measurements: RBW = 1MHz, VBW = 3 MHz, Sweep: Auto.
3. Average measurements: RBW = 1MHz, VBW = 10 Hz, Sweep: Auto.
4. Measurement Level = Reading Level + Correct Factor.
5. Correct Factor = Antenna factor + Cable loss – Amplifier gain.
6. The average measurement was not performed when the peak measured data under the limit of average detection.
7. The emission levels of other frequencies are very lower than the limit and not show in test report.

Product : Medical Cart Computer
 Test Item : General Radiated Emission
 Test Site : No.3 OATS
 Test Mode : Mode 1: Transmit - 1Mbps (GFSK) (2441MHz) (19'')

Frequency MHz	Correct Factor dB	Reading Level dB μ V	Measurement Level dB μ V/m	Margin dB	Limit dB μ V/m
Horizontal					
166.362	-10.996	44.594	33.598	-9.902	43.500
332.246	-4.247	30.625	26.378	-19.622	46.000
474.232	0.032	26.930	26.962	-19.038	46.000
614.812	3.419	28.038	31.457	-14.543	46.000
779.290	4.178	23.158	27.337	-18.663	46.000
953.609	6.368	28.354	34.722	-11.278	46.000
Vertical					
146.681	-6.247	38.295	32.048	-11.452	43.500
298.507	-7.009	30.447	23.437	-22.563	46.000
460.174	-3.359	23.733	20.375	-25.625	46.000
656.986	-3.679	28.202	24.523	-21.477	46.000
817.246	3.263	19.055	22.318	-23.682	46.000
969.072	8.191	25.278	33.469	-20.531	54.000

Note:

1. All Readings below 1GHz are Quasi-Peak, above 1GHz are performed with peak and/or average measurements as necessary.
2. Peak measurements: RBW = 1MHz, VBW = 3 MHz, Sweep: Auto.
3. Average measurements: RBW = 1MHz, VBW = 10 Hz, Sweep: Auto.
4. Measurement Level = Reading Level + Correct Factor.
5. Correct Factor = Antenna factor + Cable loss – Amplifier gain.
6. The average measurement was not performed when the peak measured data under the limit of average detection.
7. The emission levels of other frequencies are very lower than the limit and not show in test report.

Product : Medical Cart Computer
 Test Item : General Radiated Emission
 Test Site : No.3 OATS
 Test Mode : Mode 2: Transmit - 3Mbps (8DPSK) (2441MHz) (19")

Frequency MHz	Correct Factor dB	Reading Level dBμV	Measurement Level dBμV/m	Margin dB	Limit dBμV/m
Horizontal					
150.899	-10.178	44.595	34.417	-9.083	43.500
330.841	-4.469	30.246	25.777	-20.223	46.000
485.478	-0.791	23.261	22.470	-23.530	46.000
635.899	2.144	26.229	28.373	-17.627	46.000
776.478	4.181	26.961	31.142	-14.858	46.000
945.174	6.537	27.072	33.609	-12.391	46.000
Vertical					
136.841	-5.190	37.097	31.907	-11.593	43.500
257.739	-7.542	35.179	27.638	-18.362	46.000
406.754	-6.650	33.918	27.268	-18.732	46.000
572.638	-5.555	30.865	25.310	-20.690	46.000
796.159	2.832	27.589	30.422	-15.578	46.000
966.261	8.016	27.814	35.830	-18.170	54.000

Note:

1. All Readings below 1GHz are Quasi-Peak, above 1GHz are performed with peak and/or average measurements as necessary.
2. Peak measurements: RBW = 1MHz, VBW = 3 MHz, Sweep: Auto.
3. Average measurements: RBW = 1MHz, VBW = 10 Hz, Sweep: Auto.
4. Measurement Level = Reading Level + Correct Factor.
5. Correct Factor = Antenna factor + Cable loss – Amplifier gain.
6. The average measurement was not performed when the peak measured data under the limit of average detection.
7. The emission levels of other frequencies are very lower than the limit and not show in test report.
8. No emission found between lowest internal used/generated frequency to 30MHz.

Product : Medical Cart Computer
 Test Item : General Radiated Emission
 Test Site : No.3 OATS
 Test Mode : Mode 1: Transmit - 1Mbps (GFSK) (2441MHz) (22'')

Frequency MHz	Correct Factor dB	Reading Level dB μ V	Measurement Level dB μ V/m	Margin dB	Limit dB μ V/m
Horizontal					
228.217	-8.811	39.060	30.250	-15.750	46.000
388.478	-1.647	22.921	21.274	-24.726	46.000
536.087	2.178	21.226	23.404	-22.596	46.000
662.609	2.082	22.054	24.136	-21.864	46.000
780.696	4.227	23.565	27.792	-18.208	46.000
940.957	6.407	23.507	29.914	-16.086	46.000
Vertical					
181.826	-9.836	37.517	27.681	-15.819	43.500
358.957	-3.855	25.467	21.612	-24.388	46.000
534.681	-0.539	24.105	23.566	-22.434	46.000
682.290	1.601	22.551	24.152	-21.848	46.000
836.928	2.201	26.130	28.331	-17.669	46.000
973.290	3.974	28.418	32.393	-21.607	54.000

Note:

1. All Readings below 1GHz are Quasi-Peak, above 1GHz are performed with peak and/or average measurements as necessary.
2. Peak measurements: RBW = 1MHz, VBW = 3 MHz, Sweep: Auto.
3. Average measurements: RBW = 1MHz, VBW = 10 Hz, Sweep: Auto.
4. Measurement Level = Reading Level + Correct Factor.
5. Correct Factor = Antenna factor + Cable loss – Amplifier gain.
6. The average measurement was not performed when the peak measured data under the limit of average detection.
7. The emission levels of other frequencies are very lower than the limit and not show in test report.

Product : Medical Cart Computer
 Test Item : General Radiated Emission
 Test Site : No.3 OATS
 Test Mode : Mode 2: Transmit - 3Mbps (8DPSK) (2441MHz) (22")

Frequency MHz	Correct Factor dB	Reading Level dB μ V	Measurement Level dB μ V/m	Margin dB	Limit dB μ V/m
Horizontal					
186.043	-11.971	41.044	29.073	-14.427	43.500
354.739	-2.501	23.244	20.742	-25.258	46.000
498.130	-0.164	26.154	25.991	-20.009	46.000
659.797	2.105	24.390	26.495	-19.505	46.000
810.217	5.055	22.152	27.207	-18.793	46.000
949.391	6.690	25.336	32.026	-13.974	46.000
Vertical					
191.667	-10.234	39.440	29.206	-14.294	43.500
321.000	-6.899	27.070	20.171	-25.829	46.000
474.232	-4.558	25.281	20.723	-25.277	46.000
655.580	-4.239	27.903	23.664	-22.336	46.000
820.058	3.332	23.844	27.176	-18.824	46.000
970.478	7.689	27.392	35.081	-18.919	54.000

Note:

1. All Readings below 1GHz are Quasi-Peak, above 1GHz are performed with peak and/or average measurements as necessary.
2. Peak measurements: RBW = 1MHz, VBW = 3 MHz, Sweep: Auto.
3. Average measurements: RBW = 1MHz, VBW = 10 Hz, Sweep: Auto.
4. Measurement Level = Reading Level + Correct Factor.
5. Correct Factor = Antenna factor + Cable loss – Amplifier gain.
6. The average measurement was not performed when the peak measured data under the limit of average detection.
7. The emission levels of other frequencies are very lower than the limit and not show in test report.
8. No emission found between lowest internal used/generated frequency to 30MHz.

5. RF Antenna Conducted Test

5.1. Test Equipment

Equipment	Manufacturer	Model No./Serial No.	Last Cal.
Spectrum Analyzer	R&S	FSP40 / 100170	Jun., 2015
Spectrum Analyzer	Agilent	E4407B / US39440758	Jun., 2015
X Spectrum Analyzer	Agilent	N9010A / MY48030495	Apr., 2015

Note: 1. All equipments are calibrated every one year.
2. The test instruments Marked “X” are used to measure the final test results.

5.2. Test Setup

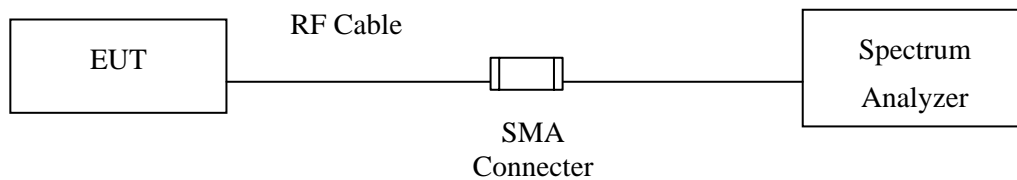

5.3. Limits

According to FCC Section 15.247(d). In any 100 kHz bandwidth outside the frequency band in which the spread spectrum or digitally modulated intentional radiator is operating, the radio frequency power that is produced by the intentional radiator shall be at least 20 dB below that in the 100 kHz bandwidth within the band that contains the highest level of the desired power, based on either an RF conducted or measurement, provided the transmitter demonstrates compliance with the peak conducted power limits. If the transmitter complies with the conducted power limits based on the use of RMS averaging over a time interval, the attenuation required under this paragraph shall be 30 dB instead of 20 dB.

5.4. Test Procedure

The EUT was setup to ANSI C63.4, 2014; tested to FHSS test procedure of FCC Public Notice DA 00-705 for compliance to FCC 47CFR 15.247 requirements.

5.5. Uncertainty

± 150Hz

5.6. Test Result of RF Antenna Conducted Test

Product : Medical Cart Computer
 Test Item : RF Antenna Conducted Test
 Test Site : No.3 OATS
 Test Mode : Mode 1: Transmit - 1Mbps (GFSK) (19''+22''+24'')

Figure Channel 00:

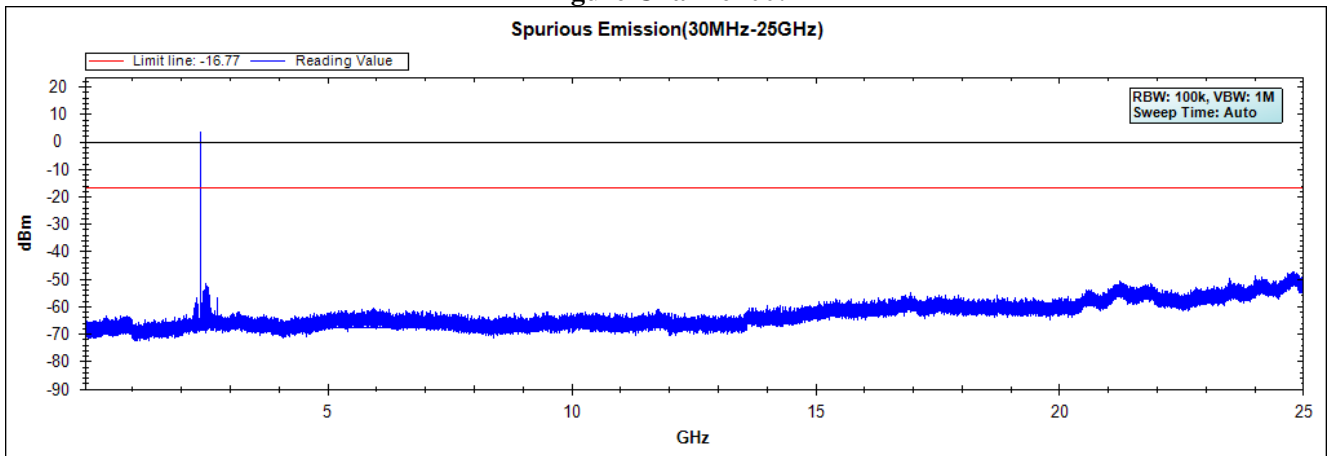

Figure Channel 39:

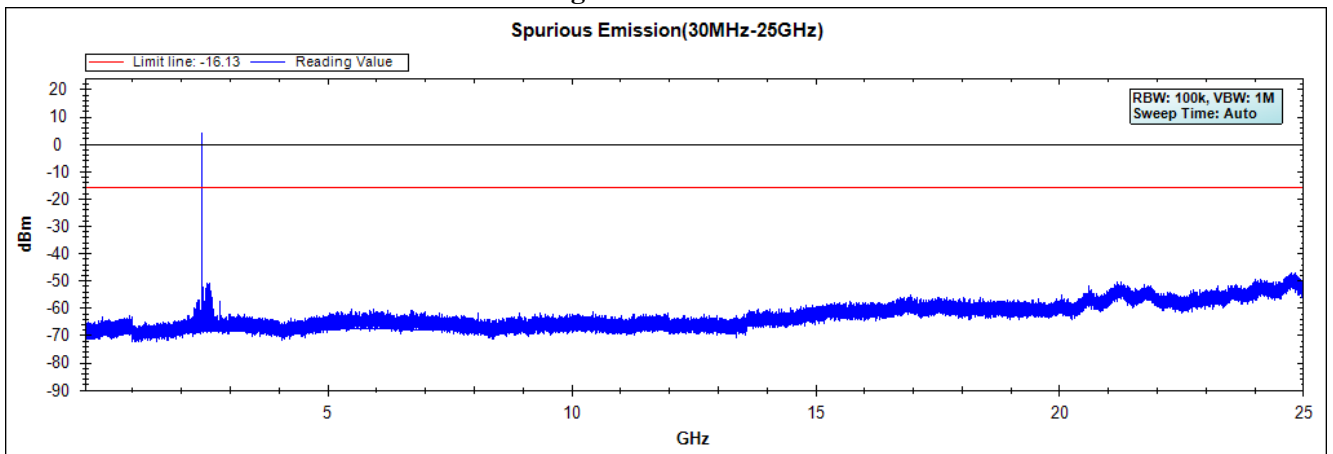
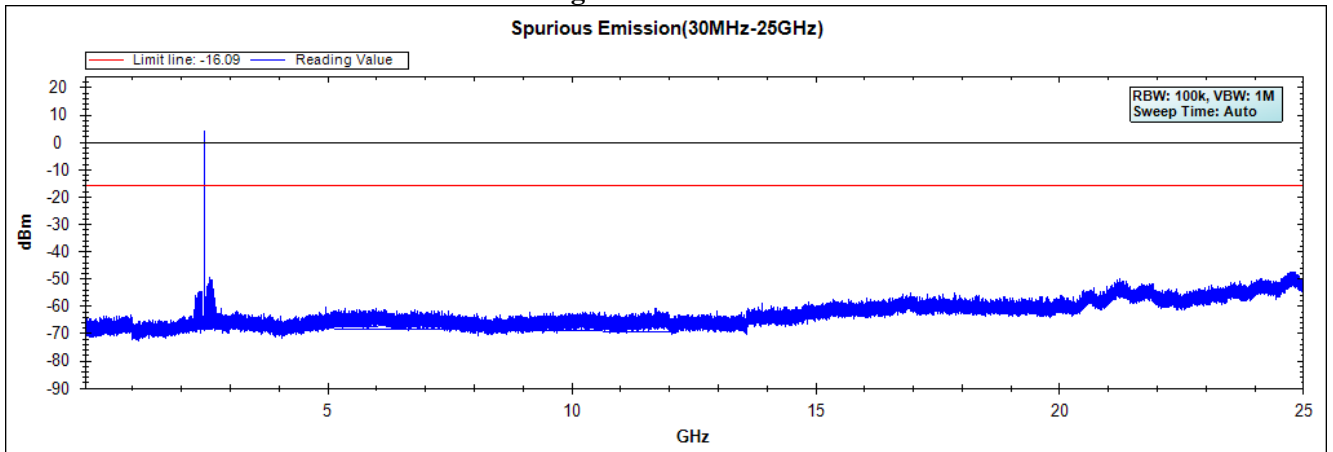

Figure Channel 78:



Note: The above test pattern is synthesized by multiple of the frequency range.

Product : Medical Cart Computer
Test Item : RF Antenna Conducted Test
Test Site : No.3 OATS
Test Mode : Mode 2: Transmit - 3Mbps (8DPSK) (19''+22''+24'')

Figure Channel 00:

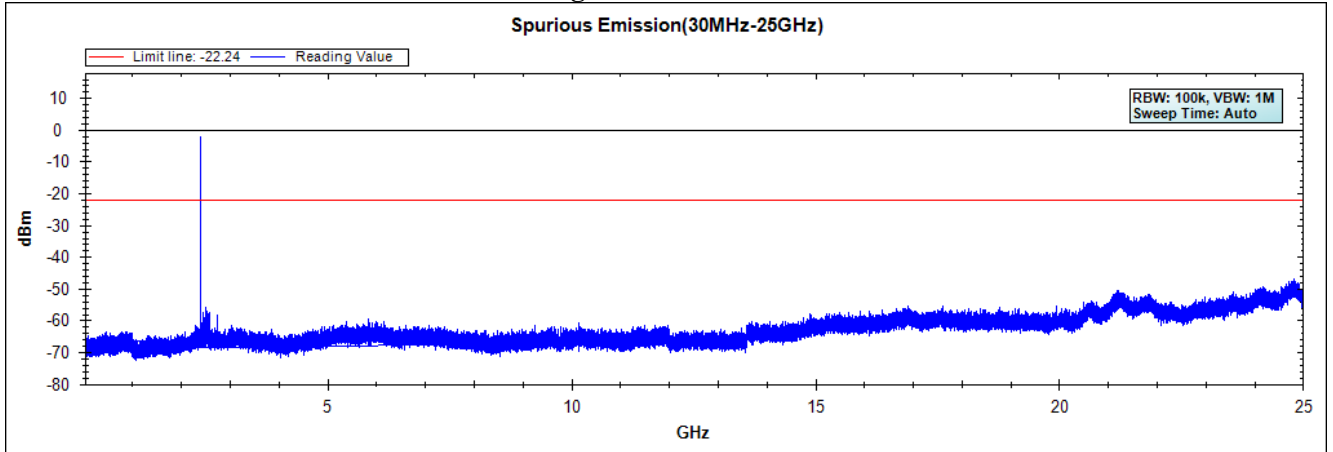

Figure Channel 39:

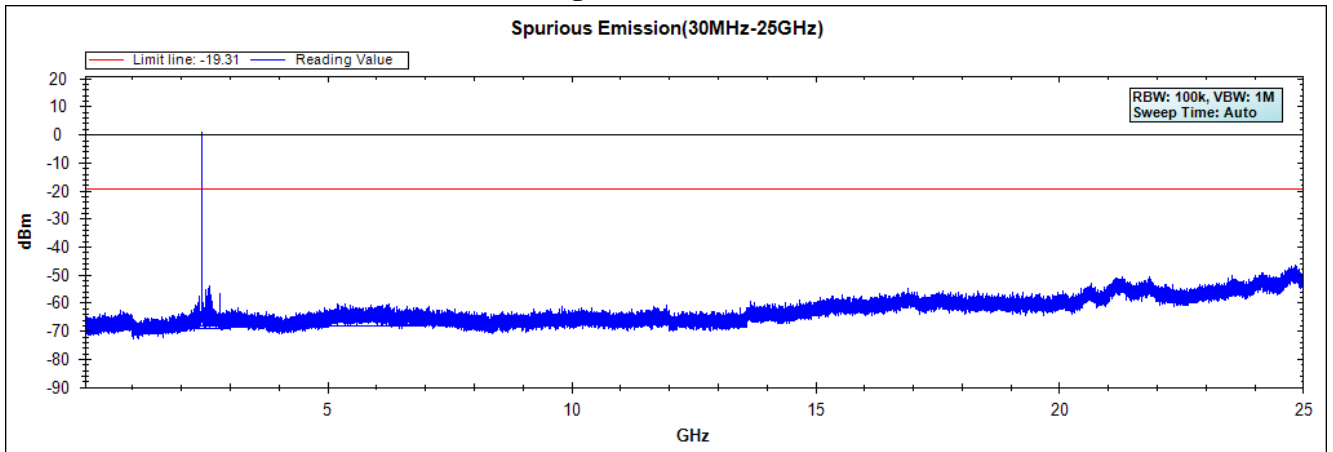
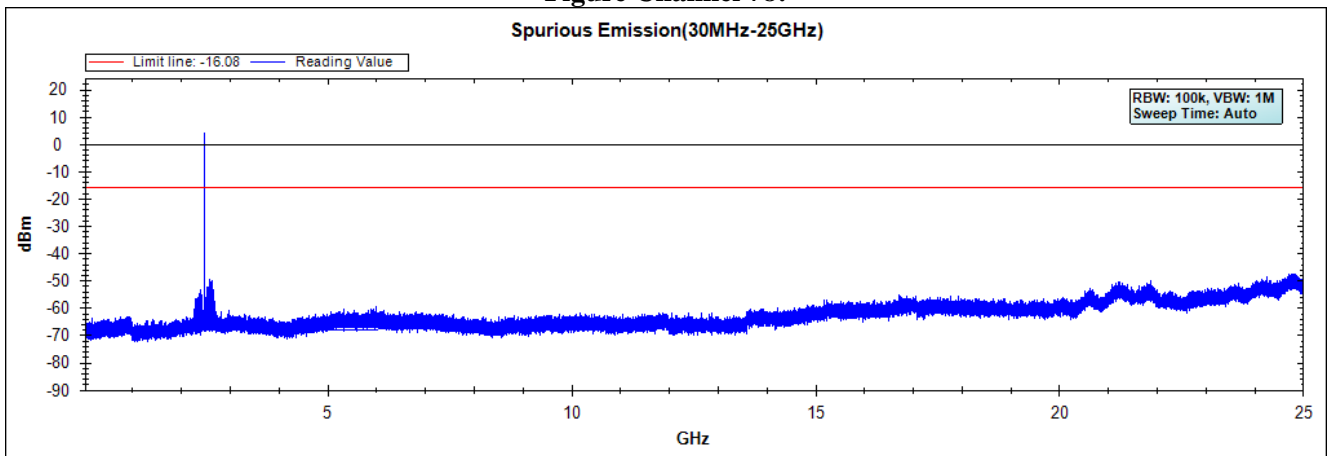

Figure Channel 78:



Note: The above test pattern is synthesized by multiple of the frequency range.

6. Band Edge

6.1. Test Equipment

RF Radiated Measurement:

The following test equipments are used during the band edge tests:

Test Site		Equipment	Manufacturer	Model No./Serial No.	Last Cal.
☒ CB # 8	X	Spectrum Analyzer	R&S	FSP40/ 100339	Oct., 2015
	X	Horn Antenna	ETS-Lindgren	3117/ 35205	Mar., 2016
	X	Horn Antenna	Schwarzbeck	BBHA9170/209	Jan., 2016
	X	Horn Antenna	TRC	AH-0801/95051	Aug., 2015
	X	Pre-Amplifier	EMCI	EMC012630SE/980210	Jan., 2016
	X	Pre-Amplifier	MITEQ	JS41-001040000-58-5P/153945	Jul., 2015
	X	Pre-Amplifier	NARDA	DBL-1840N506/013	Jul., 2015

- Note:
1. All equipments are calibrated every one year.
 2. The test instruments marked by “X” are used to measure the final test results.

6.2. Test Setup

RF Radiated Measurement:

Above 1GHz

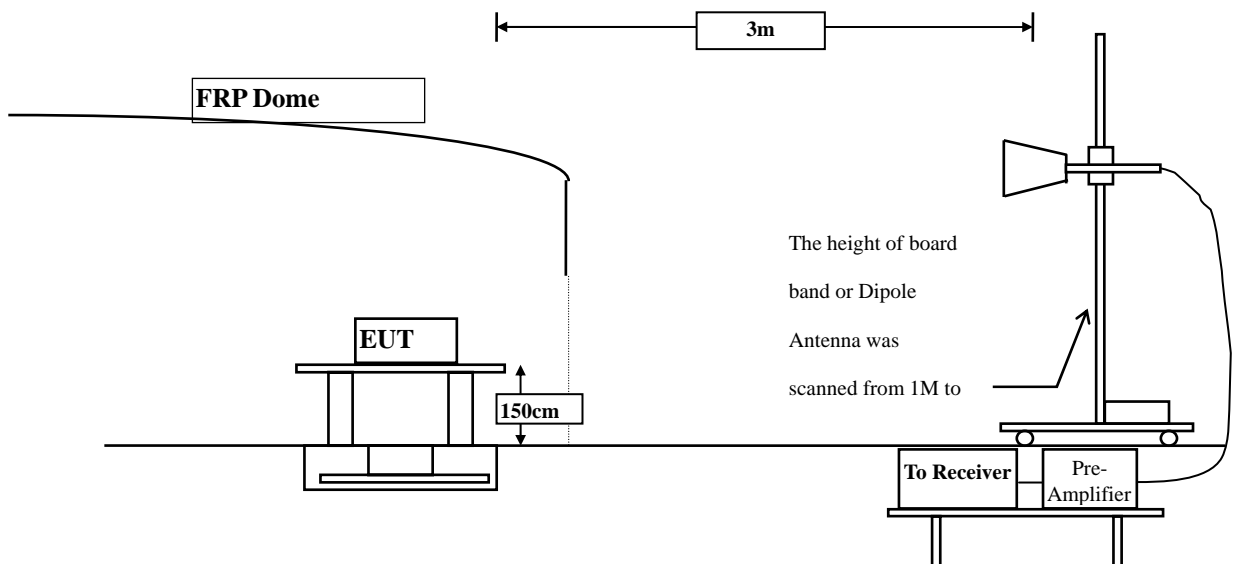

6.3. Limit

In any 100 kHz bandwidth outside the frequency band in which the spread spectrum intentional radiator is operating, the radio frequency power that is produced by the intentional radiator shall be at least 20 dB below that in the 100 kHz bandwidth within the band that contains the highest level of the desired power, based on either an RF conducted or a radiated measurement. Attenuation below the general limits specified in Section 15.209(a) is not required. In addition, radiated emissions which fall in the restricted bands, as defined in Section 15.205(a), must also comply with the radiated emission limits specified in Section 15.209(a) (see Section 15.205(c)).

6.4. Test Procedure

The EUT is placed on a turn table which is 1.5 meter above ground. The turn table is rotated 360 degrees to determine the position of the maximum emission level. The EUT was positioned such that the distance from antenna to the EUT was 3 meters.

The antenna can move up and down between 1 meter and 4 meters to find out the maximum emission level.

Both horizontal and vertical polarization of the antenna are set on measurement. In order to find the maximum emission, all of the interface cables must be manipulated according to ANSI C63.10: 2013 on radiated measurement.

The bandwidth setting below 1GHz and above 1GHz on the field strength meter is 120 kHz and 1MHz, respectively.

6.5. Uncertainty

± 3.9 dB above 1GHz

± 3.8 dB below 1GHz

6.6. Test Result of Band Edge

Product : Medical Cart Computer
 Test Item : Band Edge
 Test Site : No.3 OATS
 Test Mode : Mode 1: Transmit - 1Mbps (GFSK) (2402MHz) (19'')

RF Radiated Measurement (Horizontal):

Channel No.	Frequency (MHz)	Correct Factor (dB)	Reading Level (dBμV)	Emission Level (dBμV/m)	Peak Limit (dBμV/m)	Average Limit (dBμV/m)	Result
00 (Peak)	2390.000	31.509	25.710	57.219	74.00	54.00	Pass
00 (Peak)	2400.000	31.561	32.957	64.518	--	--	--
00 (Peak)	2402.174	31.574	67.025	98.600	--	--	--
00 (Average)	2343.768	31.329	14.520	45.848	74.00	54.00	Pass
00 (Average)	2390.000	31.509	13.562	45.071	74.00	54.00	Pass
00 (Average)	2400.000	31.561	17.443	49.004	--	--	--
00 (Average)	2402.029	31.573	55.848	87.422	--	--	--

Figure Channel 00:

Horizontal (Peak)

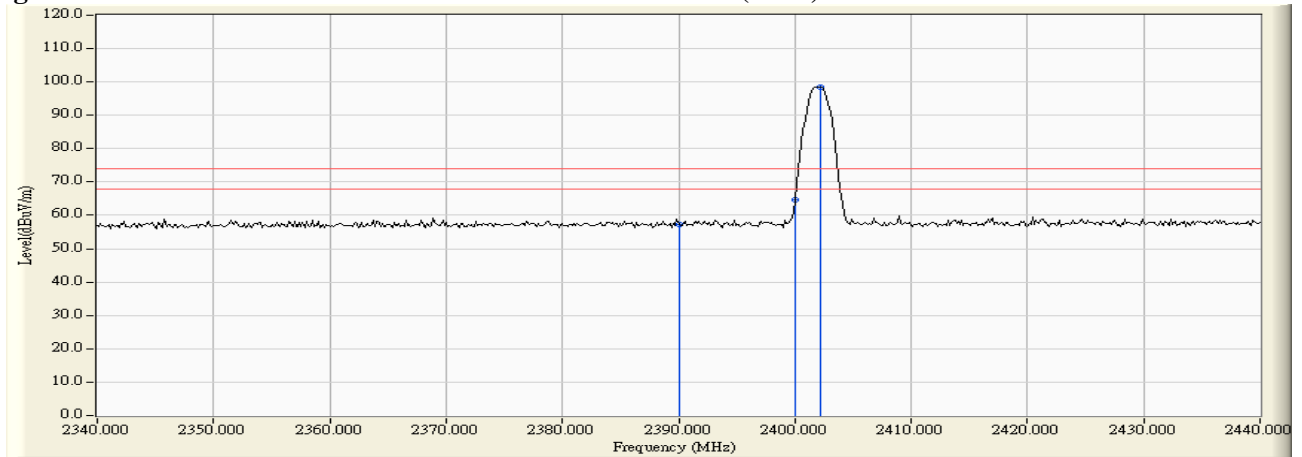
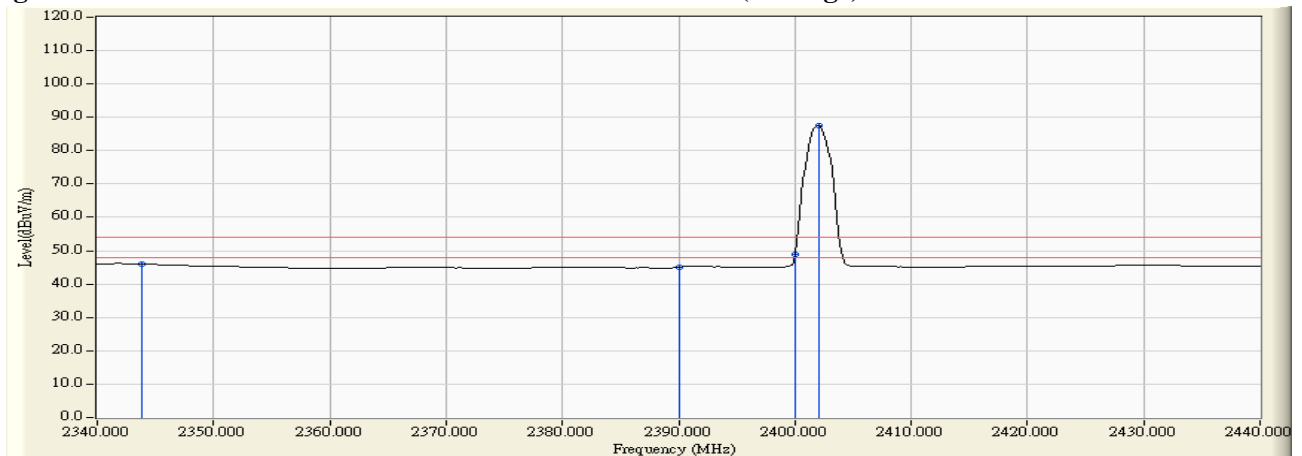

Figure Channel 00:

Horizontal (Average)



Note:

1. All readings above 1GHz are performed with peak and/or average measurements as necessary.
2. Peak measurements: RBW = 1MHz, VBW = 3 MHz, Sweep: Auto.
3. Average measurements: RBW = 1MHz, VBW = 10 Hz, Sweep: Auto.
4. “ * ”, means this data is the worst emission level.
5. Measurement Level = Reading Level + Correction Factor.
6. The average measurement was not performed when the peak measured data is under the limit of average detection.

Product : Medical Cart Computer
 Test Item : Band Edge
 Test Site : No.3 OATS
 Test Mode : Mode 1: Transmit - 1Mbps (GFSK) (2402MHz) (19'')

RF Radiated Measurement (VERTICAL):

Channel No.	Frequency (MHz)	Correct Factor (dB)	Reading Level (dBμV)	Emission Level (dBμV/m)	Peak Limit (dBμV/m)	Average Limit (dBμV/m)	Result
00 (Peak)	2390.000	30.915	28.347	59.262	74.00	54.00	Pass
00 (Peak)	2400.000	30.912	34.209	65.121	--	--	--
00 (Peak)	2402.174	30.917	67.684	98.602	--	--	--
00 (Average)	2342.754	31.134	14.651	45.785	74.00	54.00	Pass
00 (Average)	2390.000	30.915	13.749	44.664	74.00	54.00	Pass
00 (Average)	2400.000	30.912	17.873	48.785	--	--	--
00 (Average)	2402.029	30.917	56.527	87.444	--	--	--

Figure Channel 00: VERTICAL (Peak)

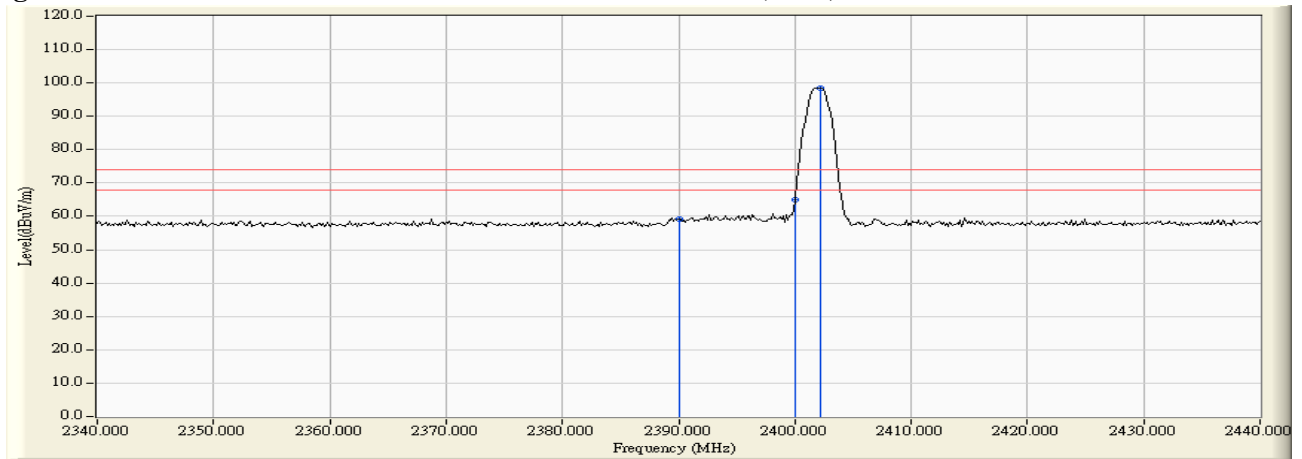
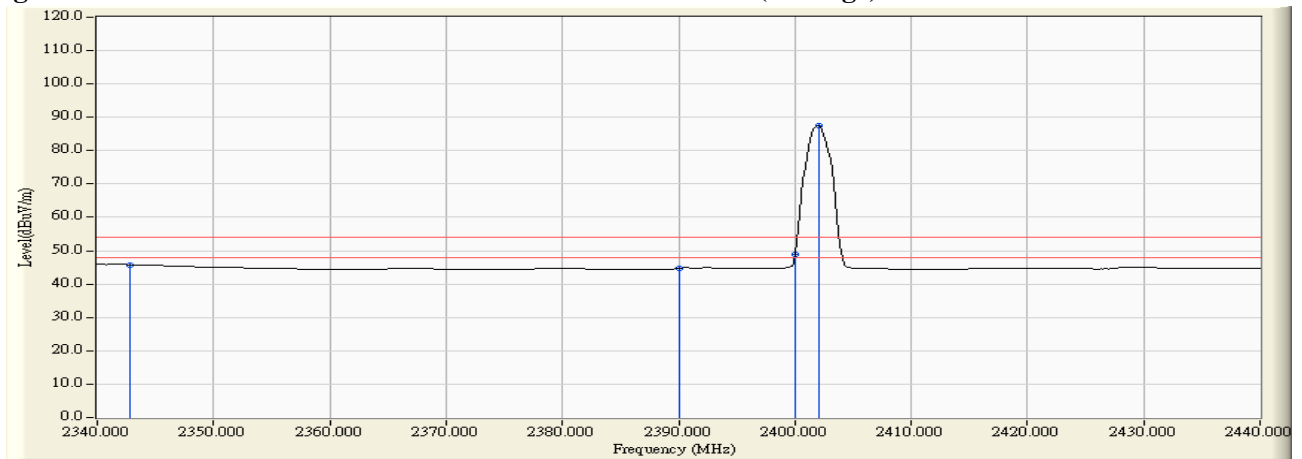

Figure Channel 00: VERTICAL (Average)



Note:

1. All readings above 1GHz are performed with peak and/or average measurements as necessary.
2. Peak measurements: RBW = 1MHz, VBW = 3 MHz, Sweep: Auto.
3. Average measurements: RBW = 1MHz, VBW = 10 Hz, Sweep: Auto.
4. “ * ”, means this data is the worst emission level.
5. Measurement Level = Reading Level + Correction Factor.
6. The average measurement was not performed when the peak measured data is under the limit of average detection.

Product : Medical Cart Computer
 Test Item : Band Edge
 Test Site : No.3 OATS
 Test Mode : Mode 1: Transmit - 1Mbps (GFSK) (2480MHz) (19")

RF Radiated Measurement (Horizontal):

Channel No.	Frequency (MHz)	Correct Factor (dB)	Reading Level (dBμV)	Emission Level (dBμV/m)	Peak Limit (dBμV/m)	Average Limit (dBμV/m)	Result
78 (Peak)	2479.877	32.155	67.772	99.927	--	--	--
78 (Peak)	2483.500	32.182	26.448	58.630	74.00	54.00	Pass
78 (Peak)	2485.384	32.196	28.722	60.918	74.00	54.00	Pass
78 (Average)	2480.022	32.156	56.242	88.398	--	--	--
78 (Average)	2483.500	32.182	14.056	46.238	74.00	54.00	Pass
78 (Average)	2508.717	32.254	15.057	47.311	74.00	54.00	Pass

Figure Channel 78: Horizontal (Peak)

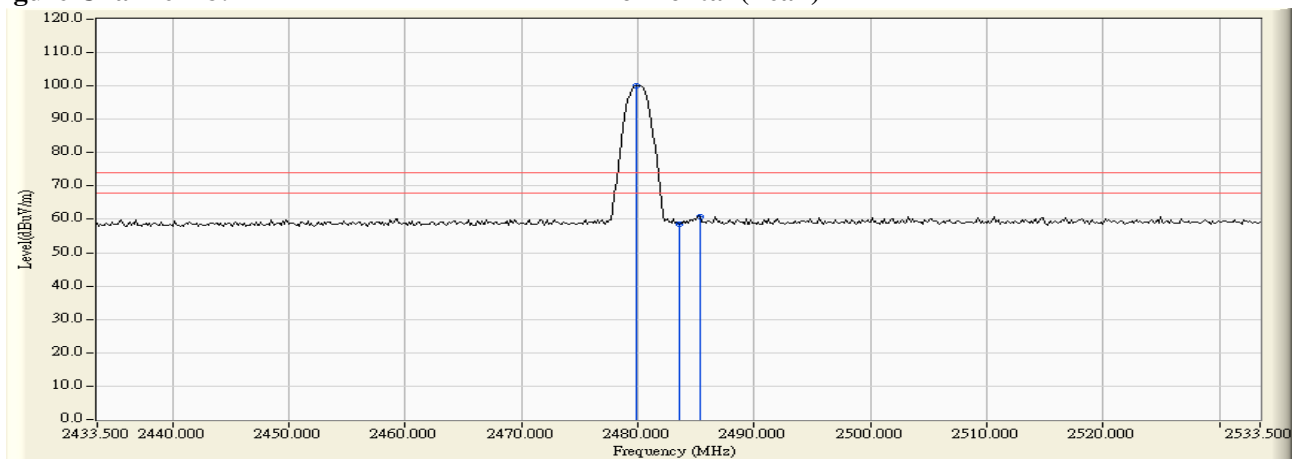
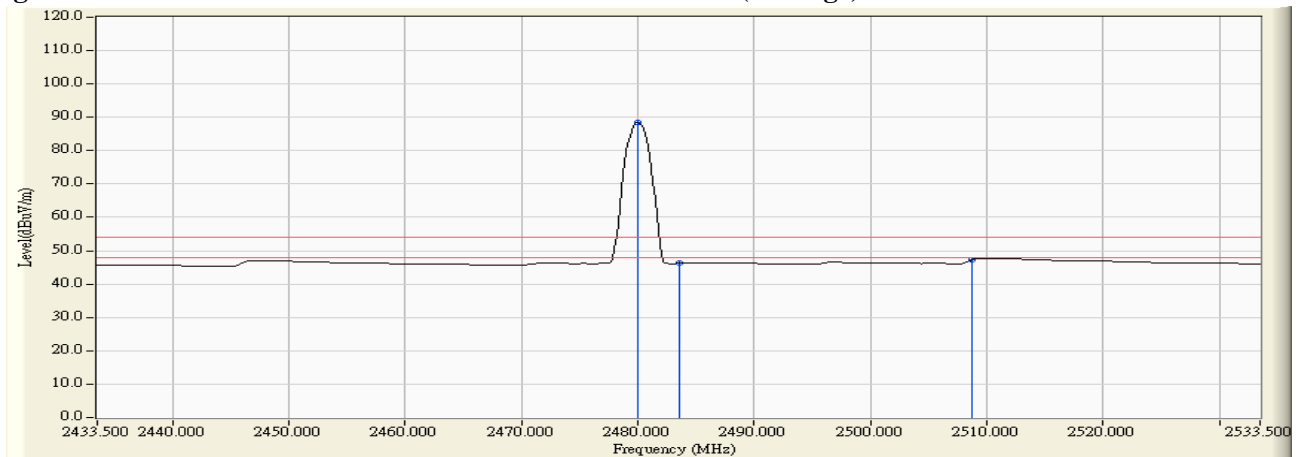

Figure Channel 78: Horizontal (Average)



Note:

1. All readings above 1GHz are performed with peak and/or average measurements as necessary.
2. Peak measurements: RBW = 1MHz, VBW = 3 MHz, Sweep: Auto.
3. Average measurements: RBW = 1MHz, VBW = 10 Hz, Sweep: Auto.
4. “ * ”, means this data is the worst emission level.
5. Measurement Level = Reading Level + Correction Factor.
6. The average measurement was not performed when the peak measured data is under the limit of average detection.

Product : Medical Cart Computer
 Test Item : Band Edge
 Test Site : No.3 OATS
 Test Mode : Mode 1: Transmit - 1Mbps (GFSK) (2480MHz) (19'')

RF Radiated Measurement (VERTICAL):

Channel No.	Frequency (MHz)	Correct Factor (dB)	Reading Level (dBμV)	Emission Level (dBμV/m)	Peak Limit (dBμV/m)	Average Limit (dBμV/m)	Result
78 (Peak)	2479.877	31.411	70.417	101.828	--	--	--
78 (Peak)	2483.500	31.435	27.264	58.699	74.00	54.00	Pass
78 (Peak)	2488.283	31.467	28.499	59.967	74.00	54.00	Pass
78 (Average)	2480.022	31.412	59.530	90.942	--	--	--
78 (Average)	2483.500	31.435	14.139	45.574	74.00	54.00	Pass
78 (Average)	2509.587	31.546	15.452	46.998	74.00	54.00	Pass

Figure Channel 78: VERTICAL (Peak)

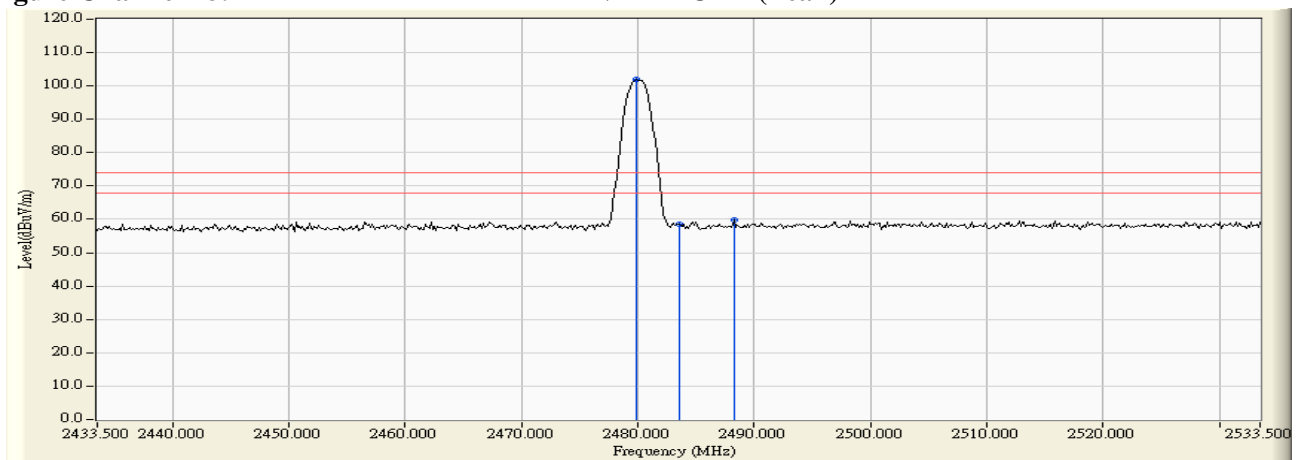
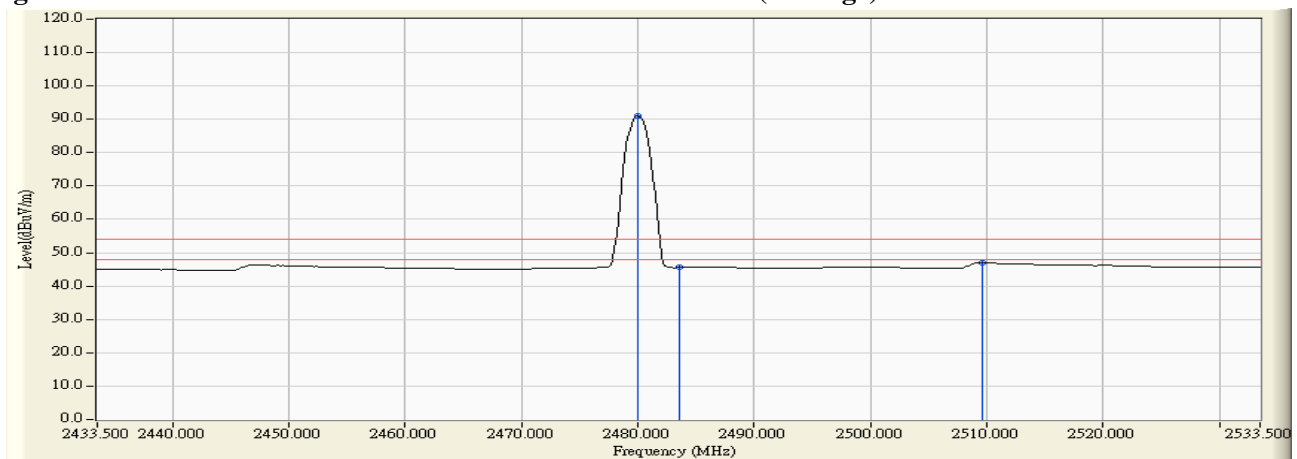

Figure Channel 78: VERTICAL (Average)



Note:

1. All readings above 1GHz are performed with peak and/or average measurements as necessary.
2. Peak measurements: RBW = 1MHz, VBW = 3 MHz, Sweep: Auto.
3. Average measurements: RBW = 1MHz, VBW = 10 Hz, Sweep: Auto.
4. “ * ”, means this data is the worst emission level.
5. Measurement Level = Reading Level + Correction Factor.
6. The average measurement was not performed when the peak measured data is under the limit of average detection.

Product : Medical Cart Computer
 Test Item : Band Edge
 Test Site : No.3 OATS
 Test Mode : Mode 2: Transmit - 3Mbps (8DPSK) (2402MHz) (19")

RF Radiated Measurement (Horizontal):

Channel No.	Frequency (MHz)	Correct Factor (dB)	Reading Level (dBμV)	Emission Level (dBμV/m)	Peak Limit (dBμV/m)	Average Limit (dBμV/m)	Result
00 (Peak)	2370.870	31.435	29.541	60.975	74.00	54.00	Pass
00 (Peak)	2390.000	31.509	28.061	59.570	74.00	54.00	Pass
00 (Peak)	2400.000	31.561	37.075	68.636	--	--	--
00 (Peak)	2402.029	31.573	64.037	95.611	--	--	--
00 (Average)	2345.507	31.335	14.491	45.826	74.00	54.00	Pass
00 (Average)	2390.000	31.509	13.553	45.062	74.00	54.00	Pass
00 (Average)	2400.000	31.561	22.348	53.909	--	--	--
00 (Average)	2402.029	31.573	50.932	82.506	--	--	--

Figure Channel 00: Horizontal (Peak)

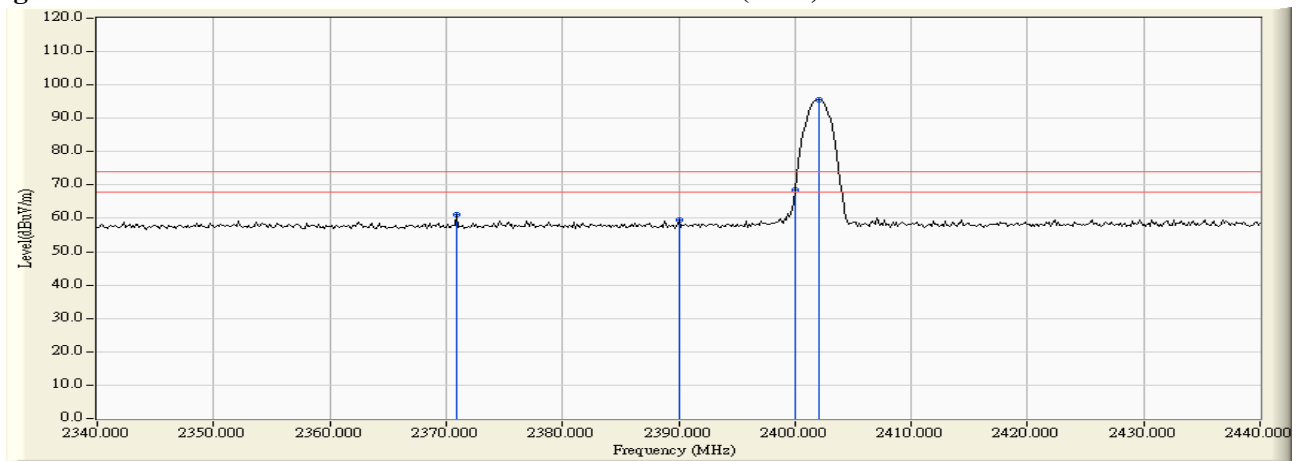
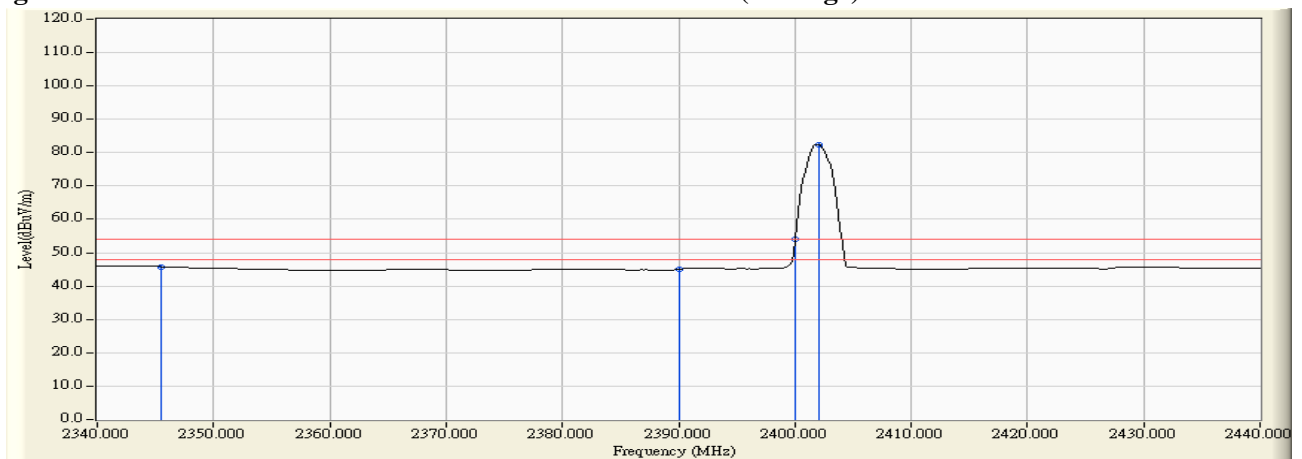

Figure Channel 00: Horizontal (Average)



Note:

1. All readings above 1GHz are performed with peak and/or average measurements as necessary.
2. Peak measurements: RBW = 1MHz, VBW = 3 MHz, Sweep: Auto.
3. Average measurements: RBW = 1MHz, VBW = 10 Hz, Sweep: Auto.
4. “ * ”, means this data is the worst emission level.
5. Measurement Level = Reading Level + Correction Factor.
6. The average measurement was not performed when the peak measured data is under the limit of average detection.

Product : Medical Cart Computer
 Test Item : Band Edge
 Test Site : No.3 OATS
 Test Mode : Mode 2: Transmit - 3Mbps (8DPSK) (2402MHz) (19")

RF Radiated Measurement (VERTICAL):

Channel No.	Frequency (MHz)	Correct Factor (dB)	Reading Level (dBμV)	Emission Level (dBμV/m)	Peak Limit (dBμV/m)	Average Limit (dBμV/m)	Result
00 (Peak)	2390.000	30.915	28.571	59.486	74.00	54.00	Pass
00 (Peak)	2400.000	30.912	37.784	68.696	--	--	--
00 (Peak)	2402.029	30.917	64.876	95.793	--	--	--
00 (Average)	2342.464	31.135	14.710	45.846	74.00	54.00	Pass
00 (Average)	2390.000	30.915	13.726	44.641	74.00	54.00	Pass
00 (Average)	2400.000	30.912	23.178	54.090	--	--	--
00 (Average)	2402.029	30.917	52.563	83.480	--	--	--

Figure Channel 00: VERTICAL (Peak)

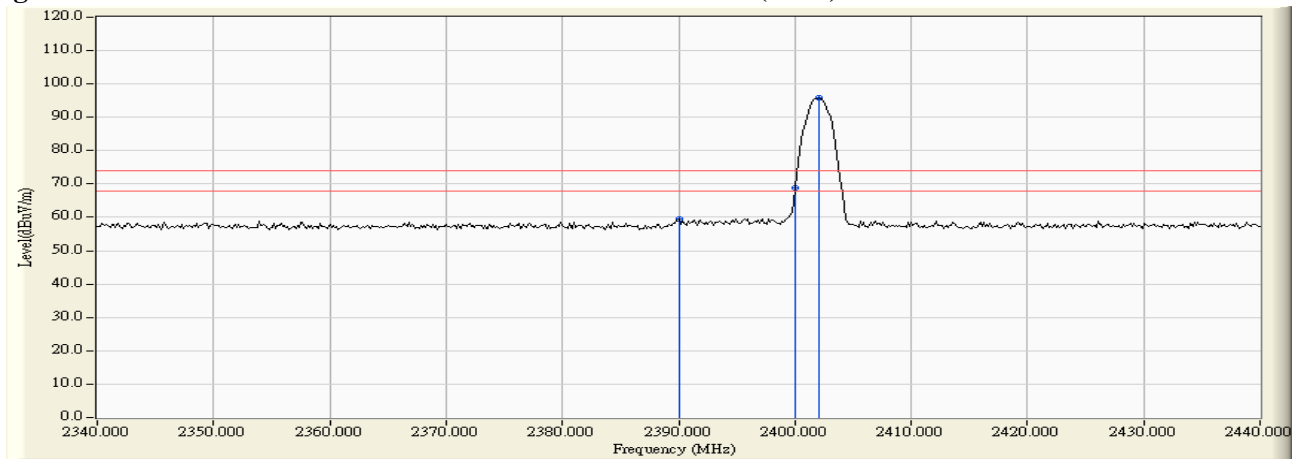
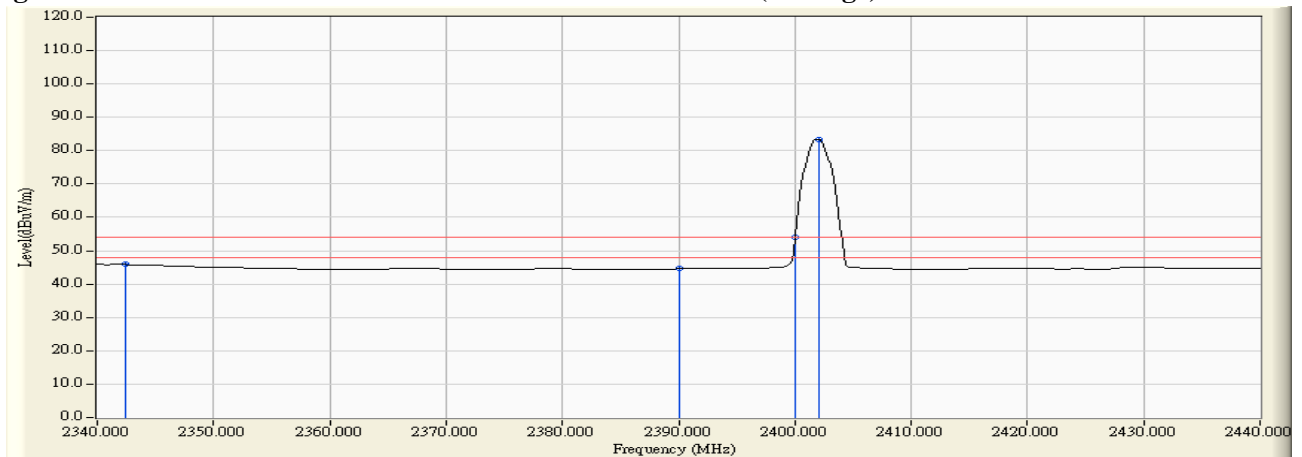

Figure Channel 00: VERTICAL (Average)



Note:

1. All readings above 1GHz are performed with peak and/or average measurements as necessary.
2. Peak measurements: RBW = 1MHz, VBW = 3 MHz, Sweep: Auto.
3. Average measurements: RBW = 1MHz, VBW = 10 Hz, Sweep: Auto.
4. “ * ”, means this data is the worst emission level.
5. Measurement Level = Reading Level + Correction Factor.
6. The average measurement was not performed when the peak measured data is under the limit of average detection.

Product : Medical Cart Computer
 Test Item : Band Edge
 Test Site : No.3 OATS
 Test Mode : Mode 2: Transmit - 3Mbps (8DPSK) (2480MHz) (19")

RF Radiated Measurement (Horizontal):

Channel No.	Frequency (MHz)	Correct Factor (dB)	Reading Level (dBμV)	Emission Level (dBμV/m)	Peak Limit (dBμV/m)	Average Limit (dBμV/m)	Result
78 (Peak)	2480.022	32.156	65.584	97.740	--	--	--
78 (Peak)	2483.500	32.182	26.839	59.021	74.00	54.00	Pass
78 (Peak)	2484.804	32.193	28.444	60.636	74.00	54.00	Pass
78 (Average)	2480.022	32.156	53.054	85.210	--	--	--
78 (Average)	2483.500	32.182	14.153	46.335	74.00	54.00	Pass
78 (Average)	2509.152	32.254	15.406	47.660	74.00	54.00	Pass

Figure Channel 00: Horizontal (Peak)

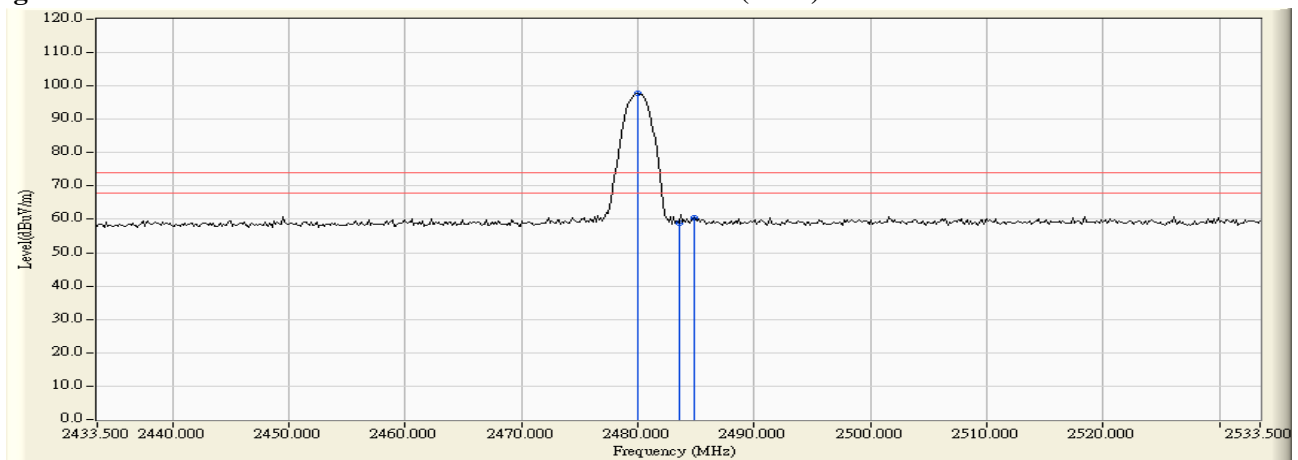
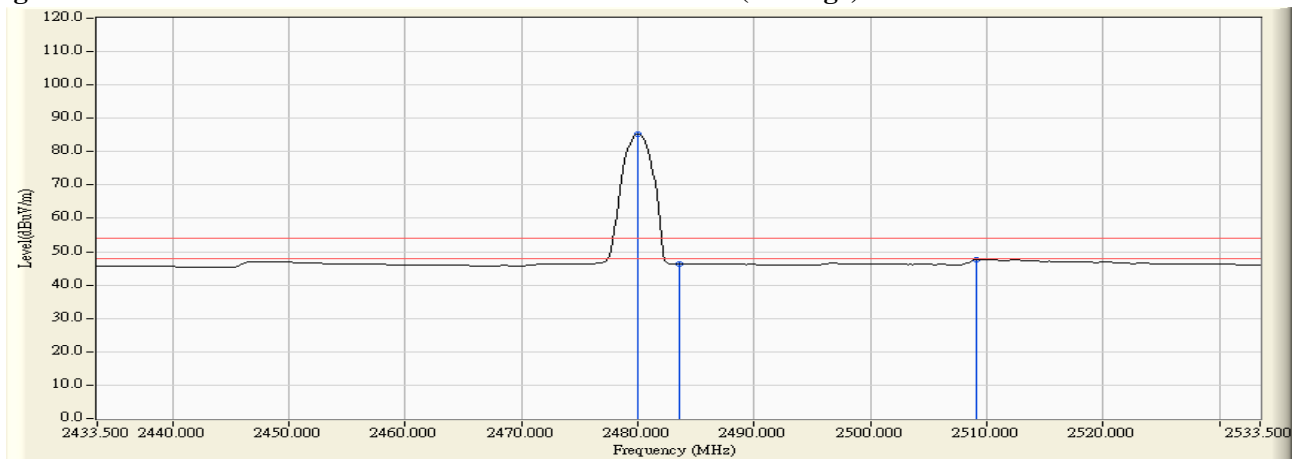

Figure Channel 00: Horizontal (Average)



Note:

1. All readings above 1GHz are performed with peak and/or average measurements as necessary.
2. Peak measurements: RBW = 1MHz, VBW = 3 MHz, Sweep: Auto.
3. Average measurements: RBW = 1MHz, VBW = 10 Hz, Sweep: Auto.
4. “ * ”, means this data is the worst emission level.
5. Measurement Level = Reading Level + Correction Factor.
6. The average measurement was not performed when the peak measured data is under the limit of average detection.

Product : Medical Cart Computer
 Test Item : Band Edge
 Test Site : No.3 OATS
 Test Mode : Mode 2: Transmit - 3Mbps (8DPSK) (2480MHz) (19")

RF Radiated Measurement (VERTICAL):

Channel No.	Frequency (MHz)	Correct Factor (dB)	Reading Level (dBμV)	Emission Level (dBμV/m)	Peak Limit (dBμV/m)	Average Limit (dBμV/m)	Result
78 (Peak)	2480.022	31.412	67.676	99.088	--	--	--
78 (Peak)	2483.500	31.435	26.241	57.676	74.00	54.00	Pass
78 (Peak)	2488.572	31.470	27.923	59.393	74.00	54.00	Pass
78 (Average)	2480.022	31.412	54.128	85.540	--	--	--
78 (Average)	2483.500	31.435	14.282	45.717	74.00	54.00	Pass
78 (Average)	2509.297	31.546	15.447	46.993	74.00	54.00	Pass

Figure Channel 78: VERTICAL (Peak)

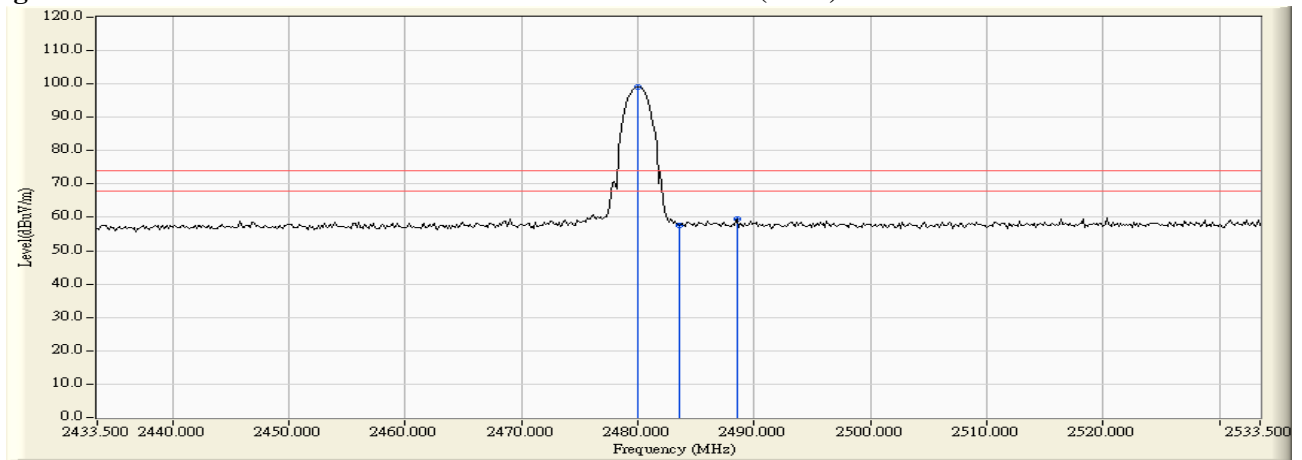
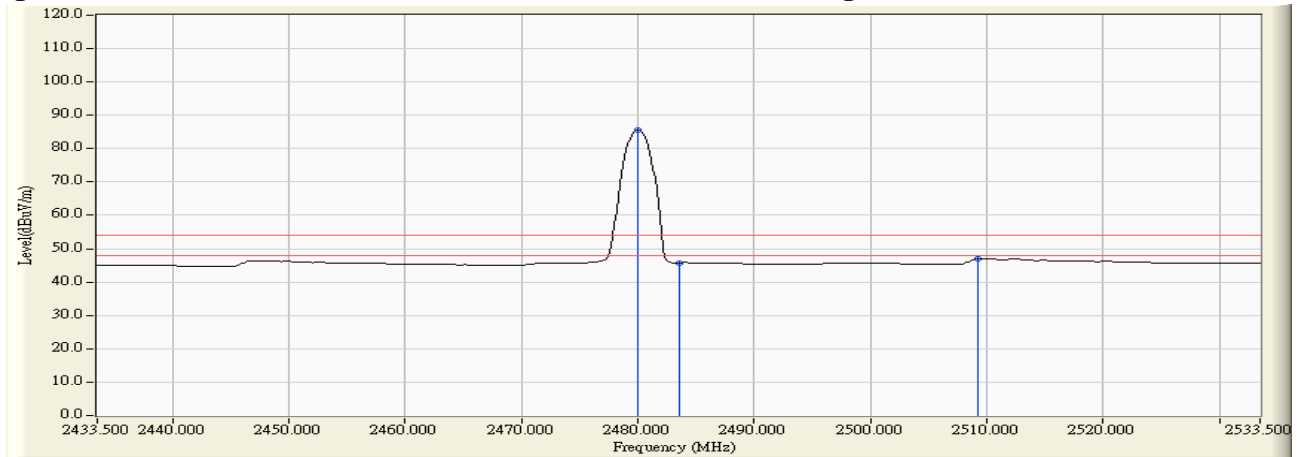

Figure Channel 78: VERTICAL (Average)



Note:

1. All readings above 1GHz are performed with peak and/or average measurements as necessary.
2. Peak measurements: RBW = 1MHz, VBW = 3 MHz, Sweep: Auto.
3. Average measurements: RBW = 1MHz, VBW = 10 Hz, Sweep: Auto.
4. “ * ”, means this data is the worst emission level.
5. Measurement Level = Reading Level + Correction Factor.
6. The average measurement was not performed when the peak measured data is under the limit of average detection.

Product : Medical Cart Computer
 Test Item : Band Edge
 Test Site : No.3 OATS
 Test Mode : Mode 1: Transmit - 1Mbps (GFSK) (2402MHz) (Hopping Bandedge) (19")

RF Radiated Measurement (Horizontal):

Channel No.	Frequency (MHz)	Correct Factor (dB)	Reading Level (dBµV)	Emission Level (dBµV/m)	Peak Limit (dBµV/m)	Average Limit (dBµV/m)	Result
00 (Peak)	2390.000	31.509	26.705	58.214	74.00	54.00	Pass
00 (Peak)	2400.000	31.561	33.101	64.662	--	--	--
00 (Peak)	2440.000	31.852	67.181	99.033	--	--	--
00 (Average)	2390.000	31.509	14.092	45.601	74.00	54.00	Pass
00 (Average)	2400.000	31.561	18.688	50.249	--	--	--
00 (Average)	2440.000	31.852	66.949	98.801	--	--	--

Figure Channel 00: Horizontal (Peak)

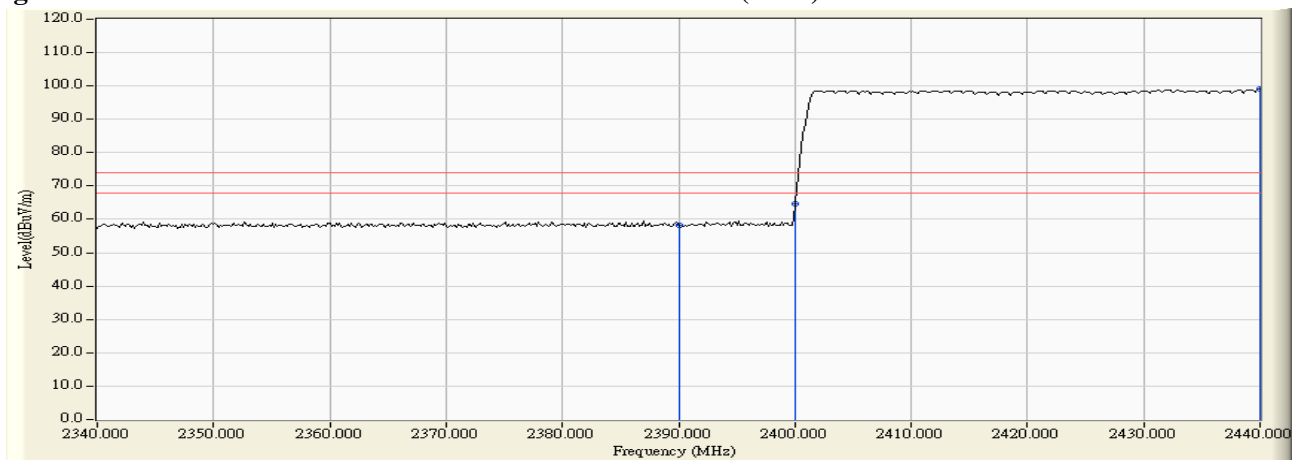
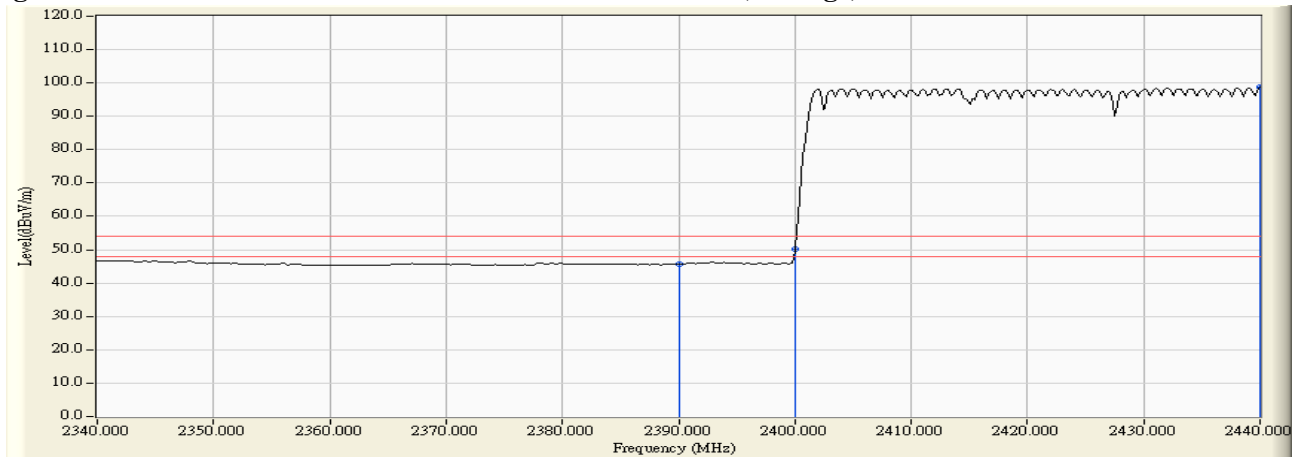

Figure Channel 00: Horizontal (Average)



Note:

1. All readings above 1GHz are performed with peak and/or average measurements as necessary.
2. Peak measurements: RBW = 1MHz, VBW = 3 MHz, Sweep: Auto.
3. Average measurements: RBW = 1MHz, VBW = 10 Hz, Sweep: Auto.
4. “ * ”, means this data is the worst emission level.
5. Measurement Level = Reading Level + Correction Factor.
6. The average measurement was not performed when the peak measured data is under the limit of average detection.

Product : Medical Cart Computer
 Test Item : Band Edge
 Test Site : No.3 OATS
 Test Mode : Mode 1: Transmit - 1Mbps (GFSK) (2402MHz) (Hopping Bandedge) (19'')

RF Radiated Measurement (VERTICAL):

Channel No.	Frequency (MHz)	Correct Factor (dB)	Reading Level (dBμV)	Emission Level (dBμV/m)	Peak Limit (dBμV/m)	Average Limit (dBμV/m)	Result
00 (Peak)	2390.000	30.915	27.848	58.763	74.00	54.00	Pass
00 (Peak)	2400.000	30.912	32.852	63.764	--	--	--
00 (Peak)	2439.855	31.138	69.367	100.505	--	--	--
00 (Average)	2342.754	31.134	15.305	46.439	74.00	54.00	Pass
00 (Average)	2390.000	30.915	14.646	45.561	74.00	54.00	Pass
00 (Average)	2400.000	30.912	19.291	50.203	--	--	--
00 (Average)	2440.000	31.139	69.150	100.289	--	--	--

Figure Channel 00: VERTICAL (Peak)

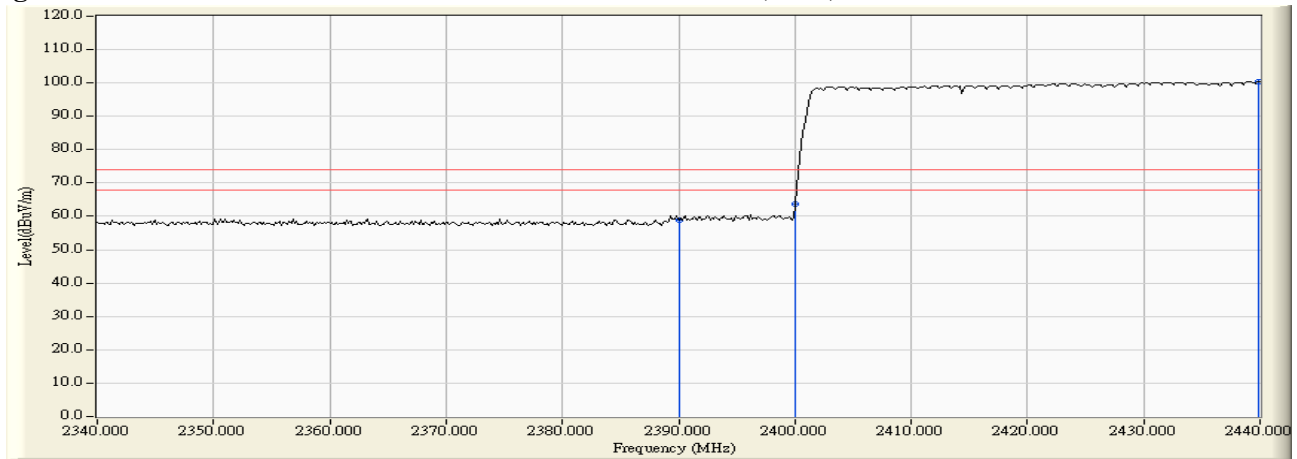
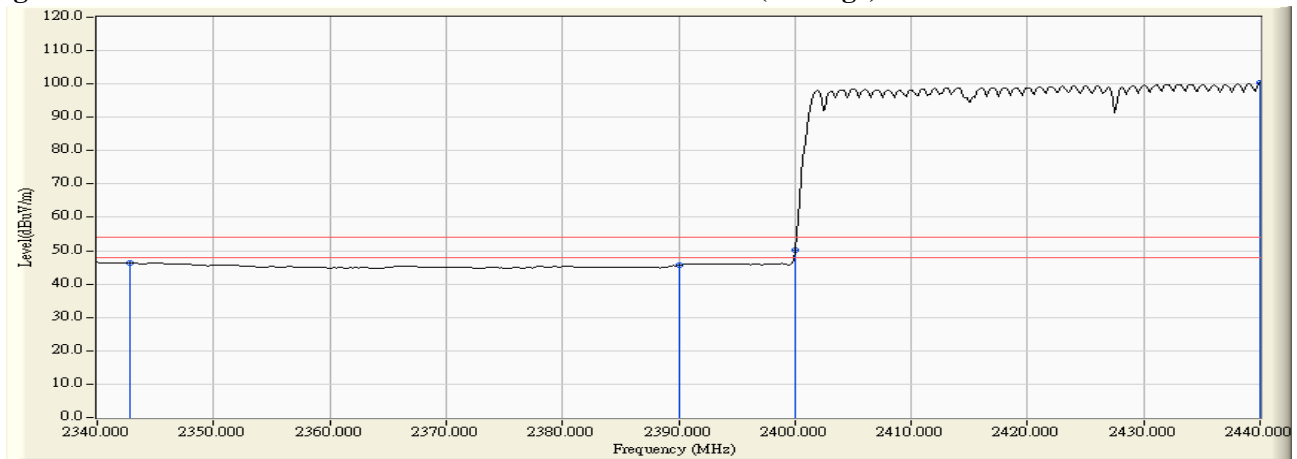

Figure Channel 00: VERTICAL (Average)



Note:

1. All readings above 1GHz are performed with peak and/or average measurements as necessary.
2. Peak measurements: RBW = 1MHz, VBW = 3 MHz, Sweep: Auto.
3. Average measurements: RBW = 1MHz, VBW = 10 Hz, Sweep: Auto.
4. “ * ”, means this data is the worst emission level.
5. Measurement Level = Reading Level + Correction Factor.
6. The average measurement was not performed when the peak measured data is under the limit of average detection.

Product : Medical Cart Computer
 Test Item : Band Edge
 Test Site : No.3 OATS
 Test Mode : Mode 1: Transmit - 1Mbps (GFSK) (2480MHz) (Hopping Bandedge) (19")

RF Radiated Measurement (Horizontal):

Channel No.	Frequency (MHz)	Correct Factor (dB)	Reading Level (dBμV)	Emission Level (dBμV/m)	Peak Limit (dBμV/m)	Average Limit (dBμV/m)	Result
78 (Peak)	2469.152	32.073	68.381	100.454	--	--	--
78 (Peak)	2483.500	32.182	26.995	59.177	74.00	54.00	Pass
78 (Peak)	2486.399	32.204	28.211	60.415	74.00	54.00	Pass
78 (Average)	2469.007	32.072	68.189	100.261	--	--	--
78 (Average)	2483.500	32.182	14.477	46.659	74.00	54.00	Pass
78 (Average)	2509.297	32.253	16.270	48.523	74.00	54.00	Pass

Figure Channel 78: Horizontal (Peak)

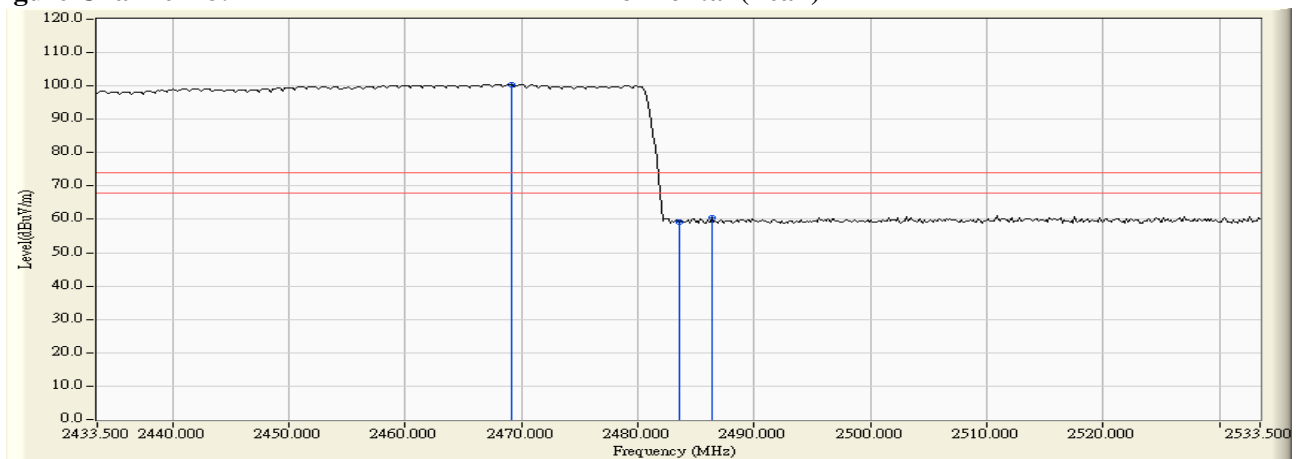
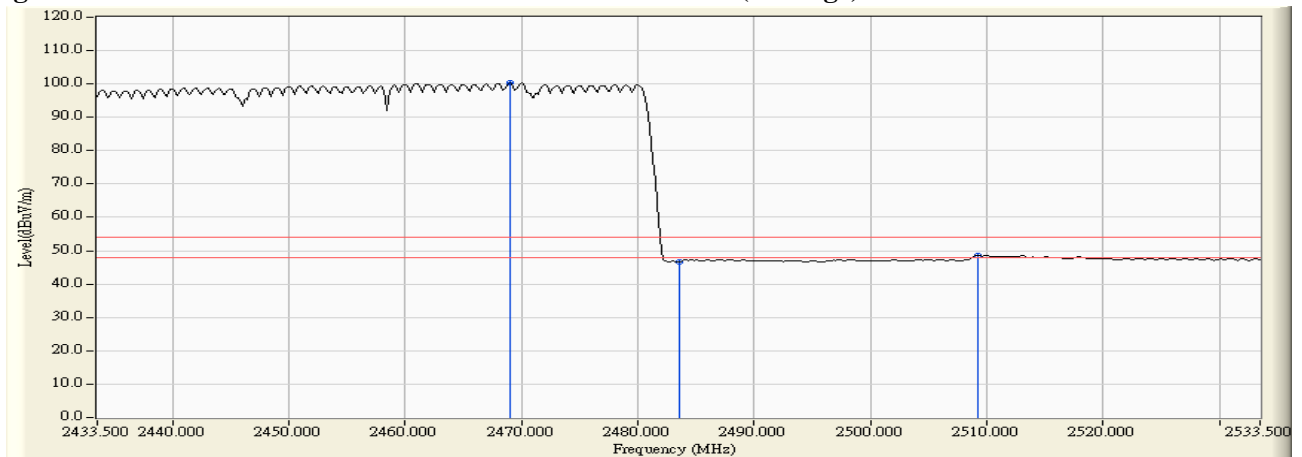

Figure Channel 78: Horizontal (Average)



Note:

1. All readings above 1GHz are performed with peak and/or average measurements as necessary.
2. Peak measurements: RBW = 1MHz, VBW = 3 MHz, Sweep: Auto.
3. Average measurements: RBW = 1MHz, VBW = 10 Hz, Sweep: Auto.
4. “ * ”, means this data is the worst emission level.
5. Measurement Level = Reading Level + Correction Factor.
6. The average measurement was not performed when the peak measured data is under the limit of average detection.

Product : Medical Cart Computer
 Test Item : Band Edge
 Test Site : No.3 OATS
 Test Mode : Mode 1: Transmit - 1Mbps (GFSK) (2480MHz) (Hopping Bandedge) (19")

RF Radiated Measurement (VERTICAL):

Channel No.	Frequency (MHz)	Correct Factor (dB)	Reading Level (dBμV)	Emission Level (dBμV/m)	Peak Limit (dBμV/m)	Average Limit (dBμV/m)	Result
78 (Peak)	2469.152	31.338	70.836	102.175	--	--	--
78 (Peak)	2483.500	31.435	27.508	58.943	74.00	54.00	Pass
78 (Peak)	2530.891	31.558	28.671	60.229	74.00	54.00	Pass
78 (Average)	2469.007	31.338	70.722	102.060	--	--	--
78 (Average)	2483.500	31.435	14.656	46.091	74.00	54.00	Pass
78 (Average)	2509.152	31.546	16.451	47.996	74.00	54.00	Pass

Figure Channel 78: VERTICAL (Peak)

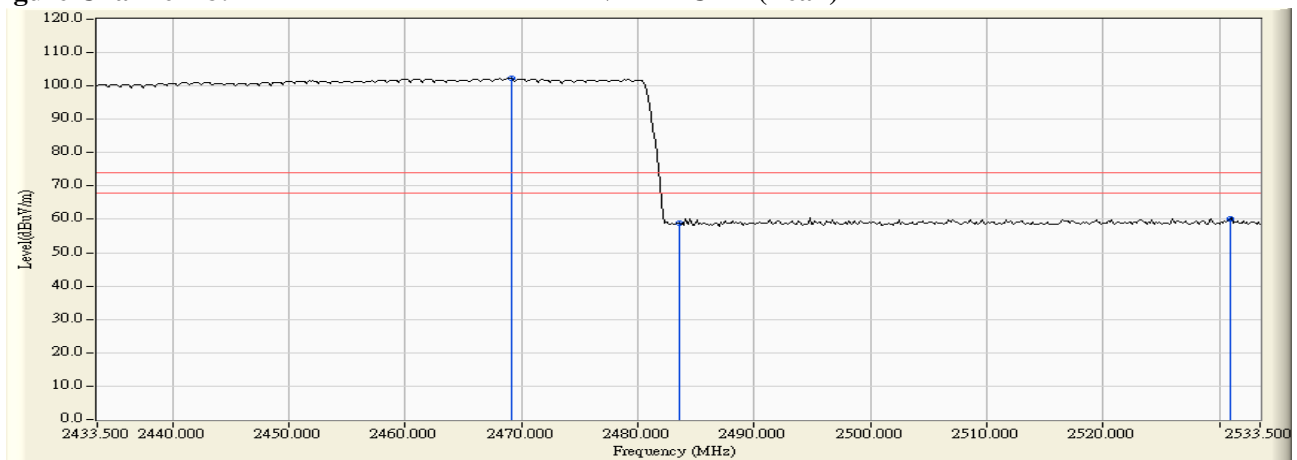
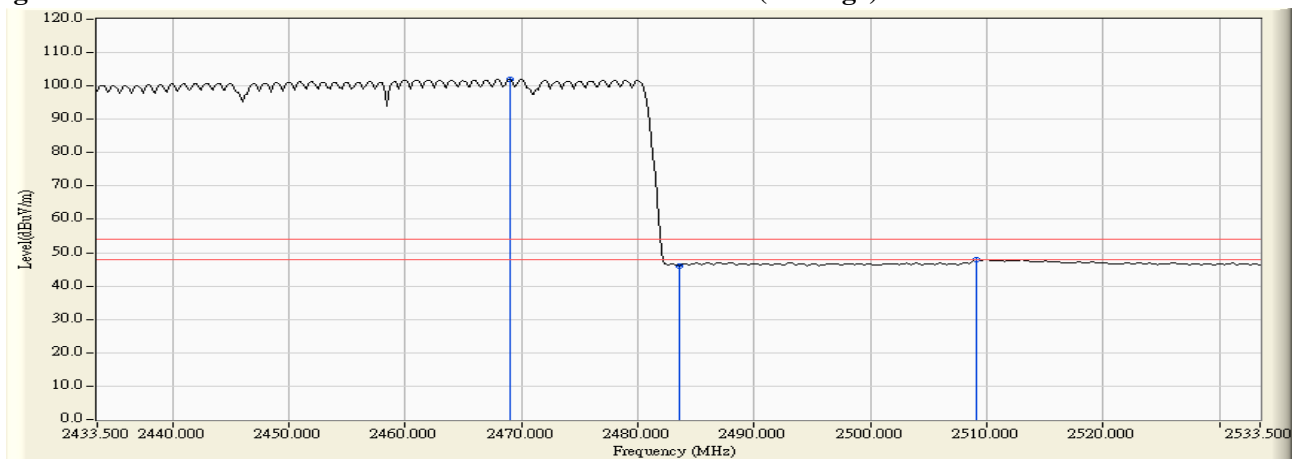

Figure Channel 78: VERTICAL (Average)



Note:

1. All readings above 1GHz are performed with peak and/or average measurements as necessary.
2. Peak measurements: RBW = 1MHz, VBW = 3 MHz, Sweep: Auto.
3. Average measurements: RBW = 1MHz, VBW = 10 Hz, Sweep: Auto.
4. “ * ”, means this data is the worst emission level.
5. Measurement Level = Reading Level + Correction Factor.
6. The average measurement was not performed when the peak measured data is under the limit of average detection.

Product : Medical Cart Computer
 Test Item : Band Edge
 Test Site : No.3 OATS
 Test Mode : Mode 2: Transmit - 3Mbps (8DPSK) (2402MHz) (Hopping Bandedge) (19'')

RF Radiated Measurement (Horizontal):

Channel No.	Frequency (MHz)	Correct Factor (dB)	Reading Level (dBμV)	Emission Level (dBμV/m)	Peak Limit (dBμV/m)	Average Limit (dBμV/m)	Result
00 (Peak)	2366.957	31.418	28.054	59.473	74.00	54.00	Pass
00 (Peak)	2390.000	31.509	27.012	58.521	74.00	54.00	Pass
00 (Peak)	2400.000	31.561	36.360	67.921	--	--	--
00 (Peak)	2440.000	31.852	64.233	96.085	--	--	--
00 (Average)	2345.362	31.334	14.935	46.269	74.00	54.00	Pass
00 (Average)	2390.000	31.509	13.863	45.372	74.00	54.00	Pass
00 (Average)	2400.000	31.561	25.290	56.851	--	--	--
00 (Average)	2440.000	31.852	61.398	93.250	--	--	--

Figure Channel 00: Horizontal (Peak)

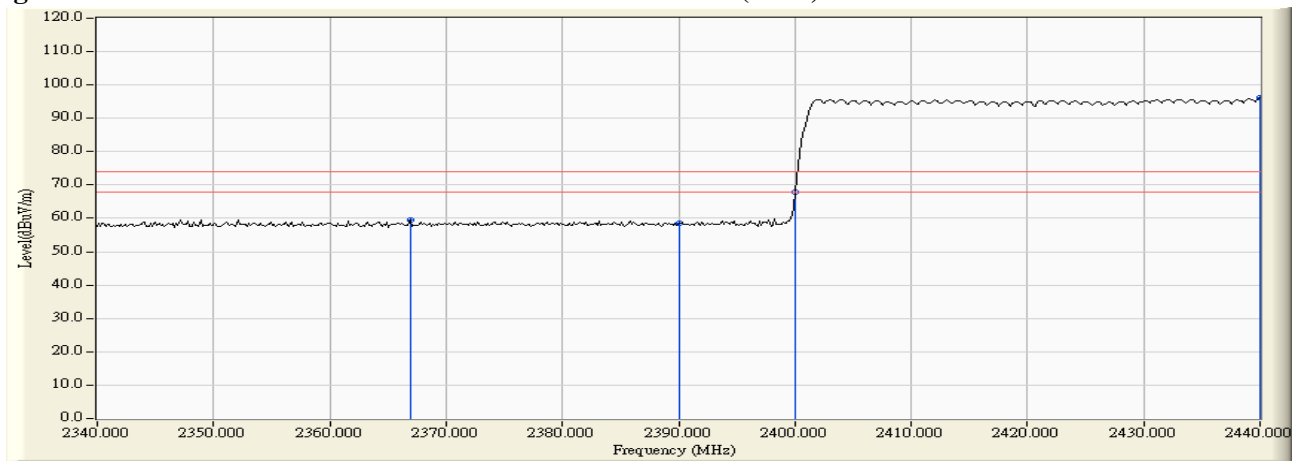
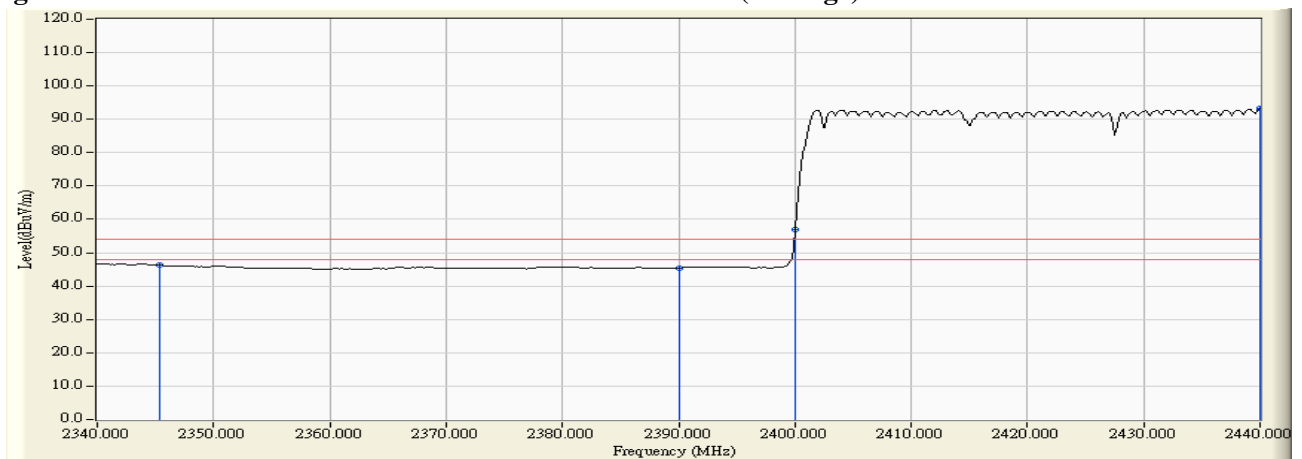

Figure Channel 00: Horizontal (Average)



Note:

1. All readings above 1GHz are performed with peak and/or average measurements as necessary.
2. Peak measurements: RBW = 1MHz, VBW = 3 MHz, Sweep: Auto.
3. Average measurements: RBW = 1MHz, VBW = 10 Hz, Sweep: Auto.
4. “ * ”, means this data is the worst emission level.
5. Measurement Level = Reading Level + Correction Factor.
6. The average measurement was not performed when the peak measured data is under the limit of average detection.

Product : Medical Cart Computer
 Test Item : Band Edge
 Test Site : No.3 OATS
 Test Mode : Mode 2: Transmit - 3Mbps (8DPSK) (2402MHz) (Hopping Bandedge) (19")

RF Radiated Measurement (VERTICAL):

Channel No.	Frequency (MHz)	Correct Factor (dB)	Reading Level (dBμV)	Emission Level (dBμV/m)	Peak Limit (dBμV/m)	Average Limit (dBμV/m)	Result
00 (Peak)	2390.000	30.915	27.913	58.828	74.00	54.00	Pass
00 (Peak)	2400.000	30.912	37.158	68.070	--	--	--
00 (Peak)	2440.000	31.139	66.875	98.014	--	--	--
00 (Average)	2342.609	31.135	15.193	46.328	74.00	54.00	Pass
00 (Average)	2390.000	30.915	14.441	45.356	74.00	54.00	Pass
00 (Average)	2400.000	30.912	26.029	56.941	--	--	--
00 (Average)	2440.000	31.139	64.045	95.184	--	--	--

Figure Channel 00: VERTICAL (Peak)

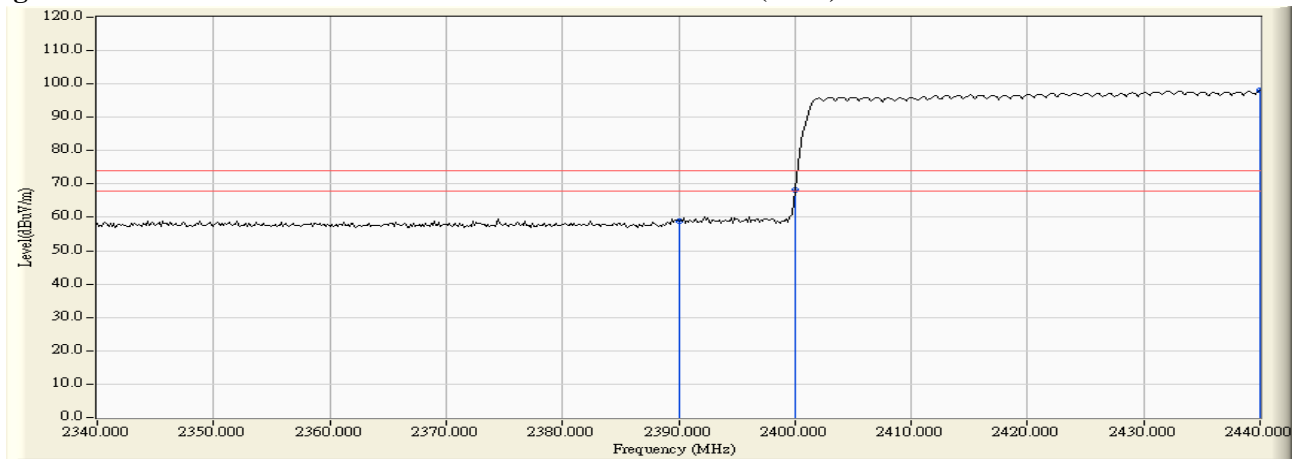
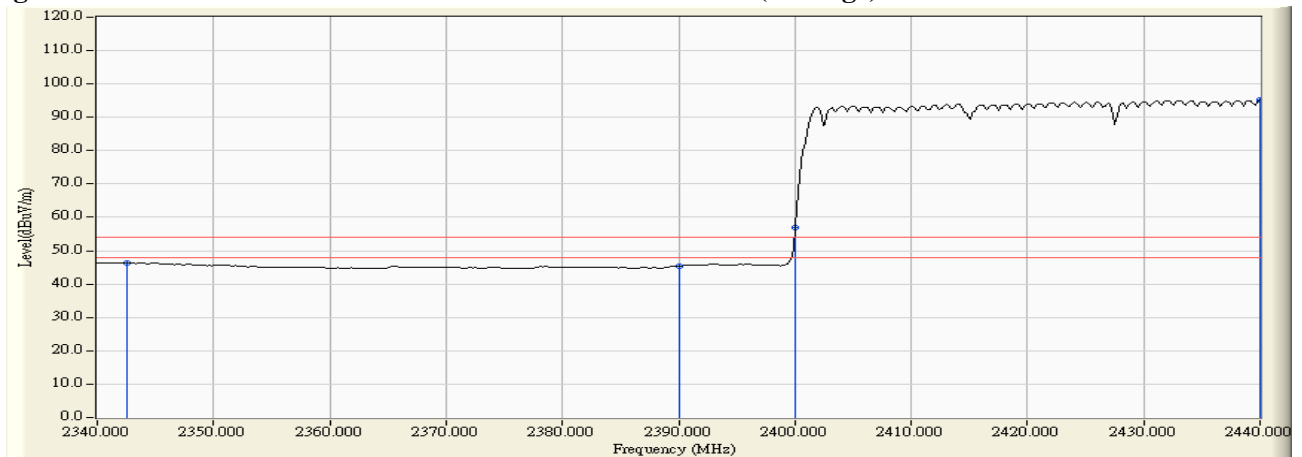

Figure Channel 00: VERTICAL (Average)



Note:

1. All readings above 1GHz are performed with peak and/or average measurements as necessary.
2. Peak measurements: RBW = 1MHz, VBW = 3 MHz, Sweep: Auto.
3. Average measurements: RBW = 1MHz, VBW = 10 Hz, Sweep: Auto.
4. “ * ”, means this data is the worst emission level.
5. Measurement Level = Reading Level + Correction Factor.
6. The average measurement was not performed when the peak measured data is under the limit of average detection.

Product : Medical Cart Computer
 Test Item : Band Edge
 Test Site : No.3 OATS
 Test Mode : Mode 2: Transmit - 3Mbps (8DPSK) (2480MHz) (Hopping Bandedge) (19")

RF Radiated Measurement (Horizontal):

Channel No.	Frequency (MHz)	Correct Factor (dB)	Reading Level (dBμV)	Emission Level (dBμV/m)	Peak Limit (dBμV/m)	Average Limit (dBμV/m)	Result
78 (Peak)	2469.007	32.072	66.123	98.195	--	--	--
78 (Peak)	2483.500	32.182	27.021	59.203	74.00	54.00	Pass
78 (Peak)	2484.804	32.193	28.663	60.855	74.00	54.00	Pass
78 (Average)	2470.022	32.080	63.310	95.390	--	--	--
78 (Average)	2483.500	32.182	14.307	46.489	74.00	54.00	Pass
78 (Average)	2509.007	32.253	16.087	48.341	74.00	54.00	Pass

Figure Channel 00: Horizontal (Peak)

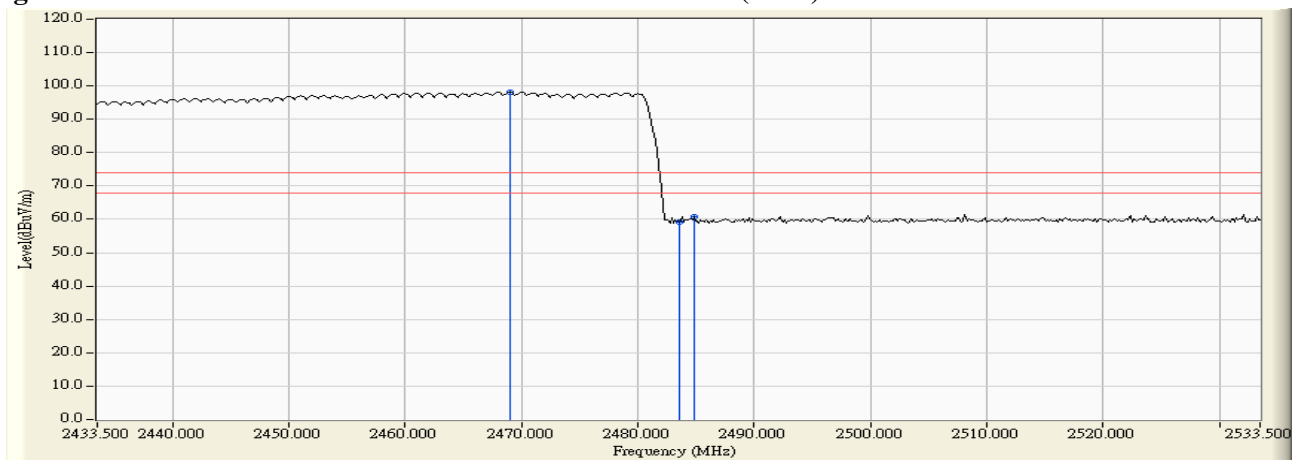
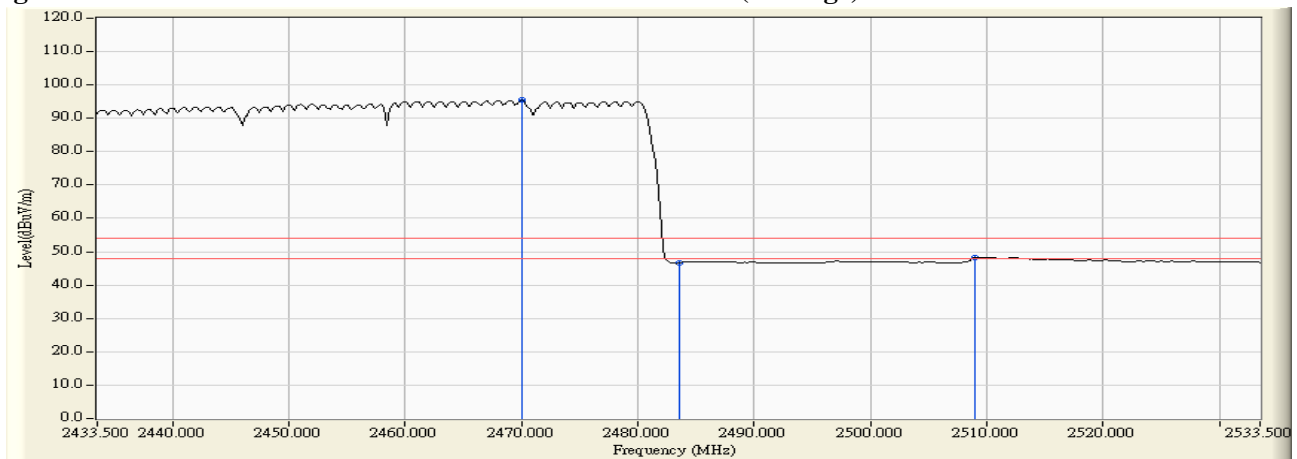

Figure Channel 00: Horizontal (Average)



Note:

1. All readings above 1GHz are performed with peak and/or average measurements as necessary.
2. Peak measurements: RBW = 1MHz, VBW = 3 MHz, Sweep: Auto.
3. Average measurements: RBW = 1MHz, VBW = 10 Hz, Sweep: Auto.
4. “ * ”, means this data is the worst emission level.
5. Measurement Level = Reading Level + Correction Factor.
6. The average measurement was not performed when the peak measured data is under the limit of average detection.

Product : Medical Cart Computer
 Test Item : Band Edge
 Test Site : No.3 OATS
 Test Mode : Mode 2: Transmit - 3Mbps (8DPSK) (2480MHz) (Hopping Bandedge) (19")

RF Radiated Measurement (VERTICAL):

Channel No.	Frequency (MHz)	Correct Factor (dB)	Reading Level (dBμV)	Emission Level (dBμV/m)	Peak Limit (dBμV/m)	Average Limit (dBμV/m)	Result
78 (Peak)	2467.993	31.331	68.259	99.590	--	--	--
78 (Peak)	2483.500	31.435	27.199	58.634	74.00	54.00	Pass
78 (Peak)	2496.399	31.520	29.166	60.686	74.00	54.00	Pass
78 (Average)	2470.022	31.344	65.504	96.848	--	--	--
78 (Average)	2483.500	31.435	14.642	46.077	74.00	54.00	Pass
78 (Average)	2509.587	31.546	15.965	47.511	74.00	54.00	Pass

Figure Channel 78: VERTICAL (Peak)

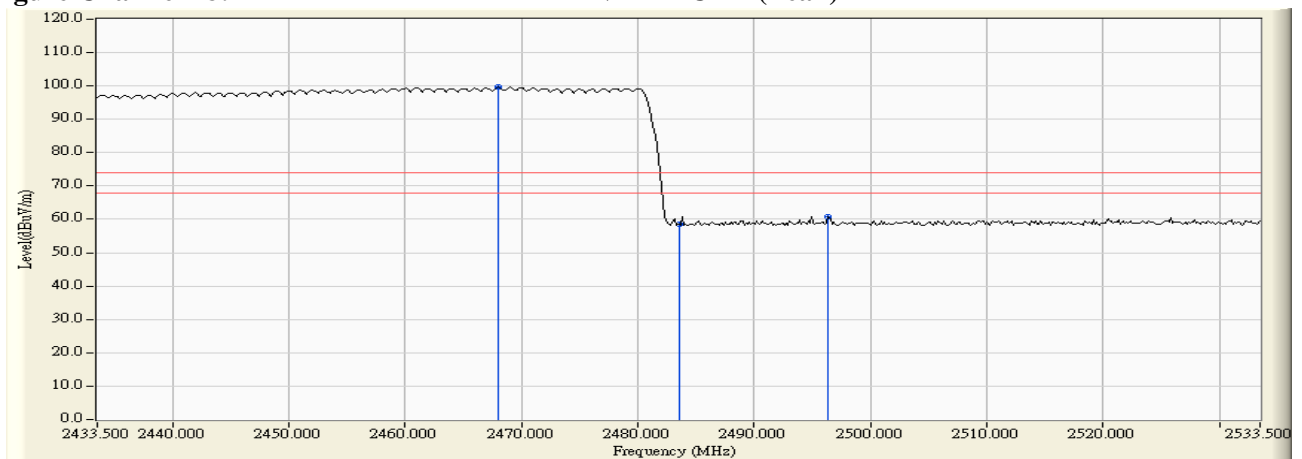
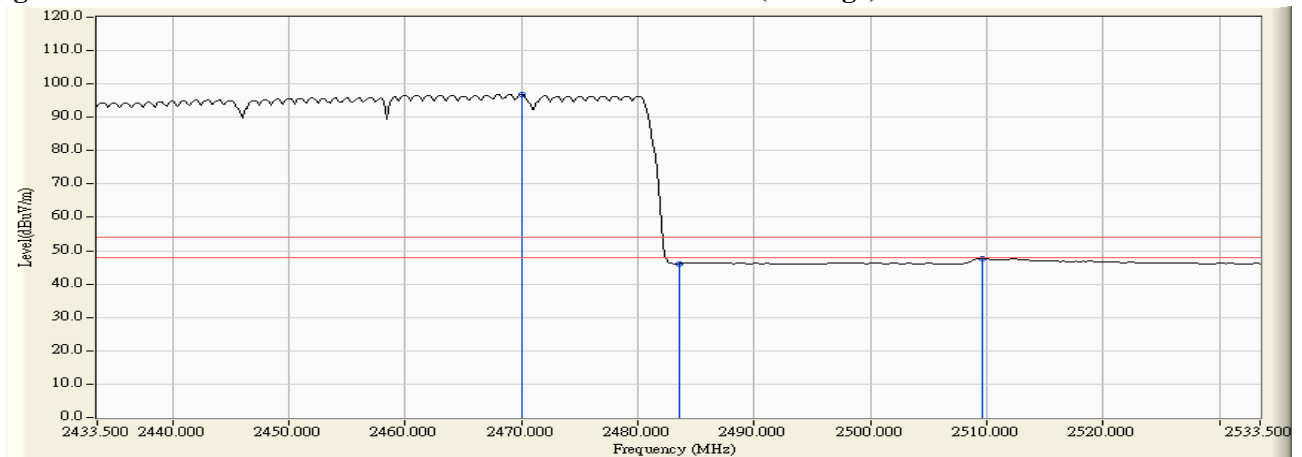

Figure Channel 78: VERTICAL (Average)



Note:

1. All readings above 1GHz are performed with peak and/or average measurements as necessary.
2. Peak measurements: RBW = 1MHz, VBW = 3 MHz, Sweep: Auto.
3. Average measurements: RBW = 1MHz, VBW = 10 Hz, Sweep: Auto.
4. “ * ”, means this data is the worst emission level.
5. Measurement Level = Reading Level + Correction Factor.
6. The average measurement was not performed when the peak measured data is under the limit of average detection.

Product : Medical Cart Computer
 Test Item : Band Edge
 Test Site : No.3 OATS
 Test Mode : Mode 1: Transmit - 1Mbps (GFSK) (2402MHz) (22")

RF Radiated Measurement (Horizontal):

Channel No.	Frequency (MHz)	Correct Factor (dB)	Reading Level (dB μ V)	Emission Level (dB μ V/m)	Peak Limit (dB μ V/m)	Average Limit (dB μ V/m)	Result
00 (Peak)	2371.594	-1.203	48.397	47.194	74.00	54.00	Pass
00 (Peak)	2390.000	-1.131	46.785	45.654	74.00	54.00	Pass
00 (Peak)	2400.000	-1.084	65.109	64.026	--	--	--
00 (Peak)	2401.884	-1.073	89.862	88.789	--	--	--
00 (Average)	2341.739	-1.319	35.056	33.736	74.00	54.00	Pass
00 (Average)	2390.000	-1.131	33.700	32.569	74.00	54.00	Pass
00 (Average)	2400.000	-1.084	44.105	43.022	--	--	--
00 (Average)	2402.029	-1.073	75.612	74.540	--	--	--

Figure Channel 00: Horizontal (Peak)

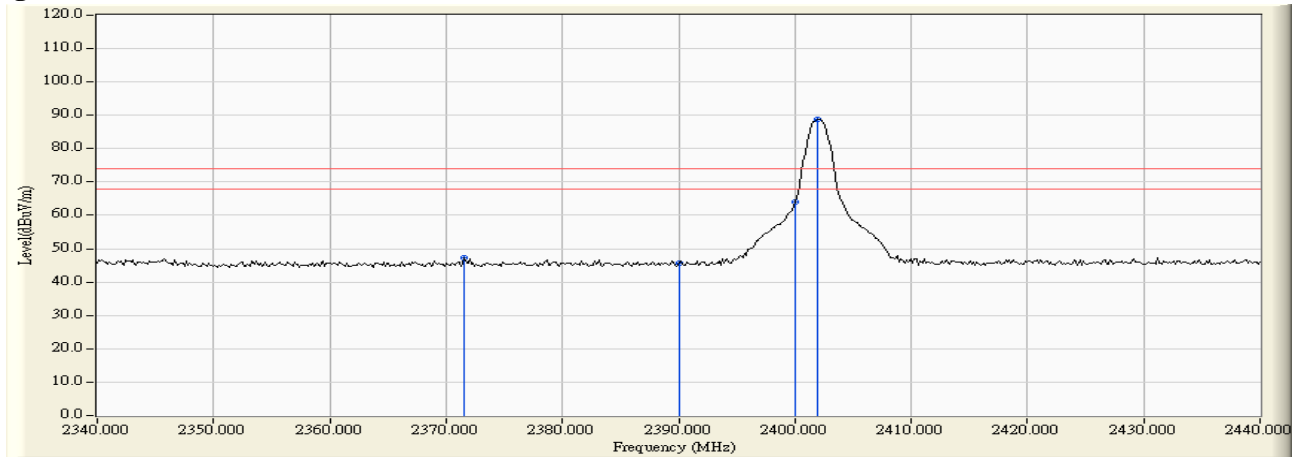
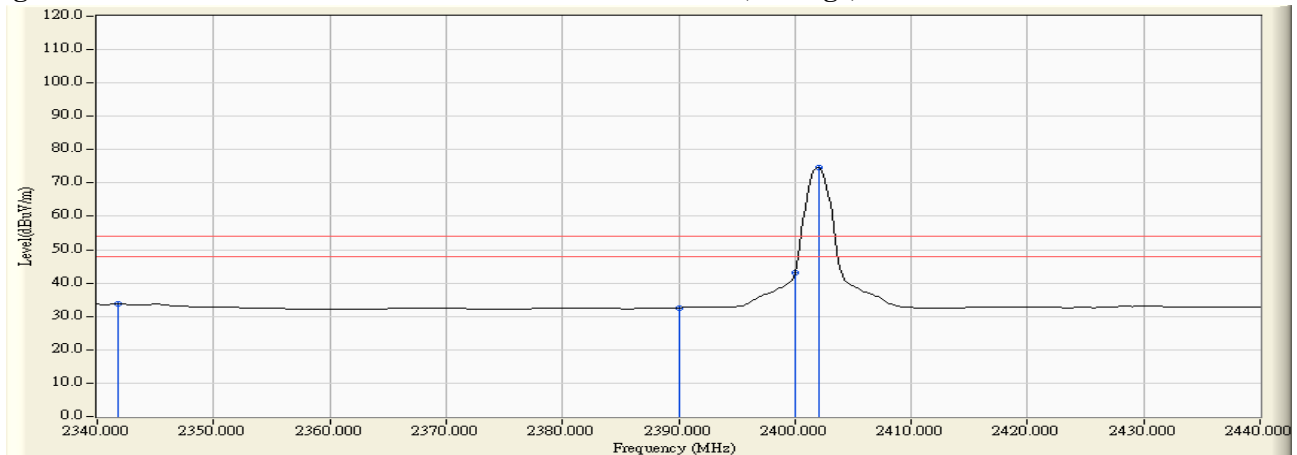

Figure Channel 00: Horizontal (Average)



Note:

1. All readings above 1GHz are performed with peak and/or average measurements as necessary.
2. Peak measurements: RBW = 1MHz, VBW = 3 MHz, Sweep: Auto.
3. Average measurements: RBW = 1MHz, VBW = 10 Hz, Sweep: Auto.
4. “ * ”, means this data is the worst emission level.
5. Measurement Level = Reading Level + Correction Factor.
6. The average measurement was not performed when the peak measured data is under the limit of average detection.

Product : Medical Cart Computer
 Test Item : Band Edge
 Test Site : No.3 OATS
 Test Mode : Mode 1: Transmit - 1Mbps (GFSK) (2402MHz) (22'')

RF Radiated Measurement (VERTICAL):

Channel No.	Frequency (MHz)	Correct Factor (dB)	Reading Level (dBμV)	Emission Level (dBμV/m)	Peak Limit (dBμV/m)	Average Limit (dBμV/m)	Result
00 (Peak)	2357.681	-1.575	48.040	46.465	74.00	54.00	Pass
00 (Peak)	2390.000	-1.725	47.169	45.444	74.00	54.00	Pass
00 (Peak)	2400.000	-1.733	60.662	58.930	--	--	--
00 (Peak)	2402.174	-1.729	85.244	83.516	--	--	--
00 (Average)	2343.768	-1.510	34.705	33.195	74.00	54.00	Pass
00 (Average)	2390.000	-1.725	33.775	32.050	74.00	54.00	Pass
00 (Average)	2400.000	-1.733	41.132	39.400	--	--	--
00 (Average)	2402.029	-1.729	71.965	70.236	--	--	--

Figure Channel 00: VERTICAL (Peak)

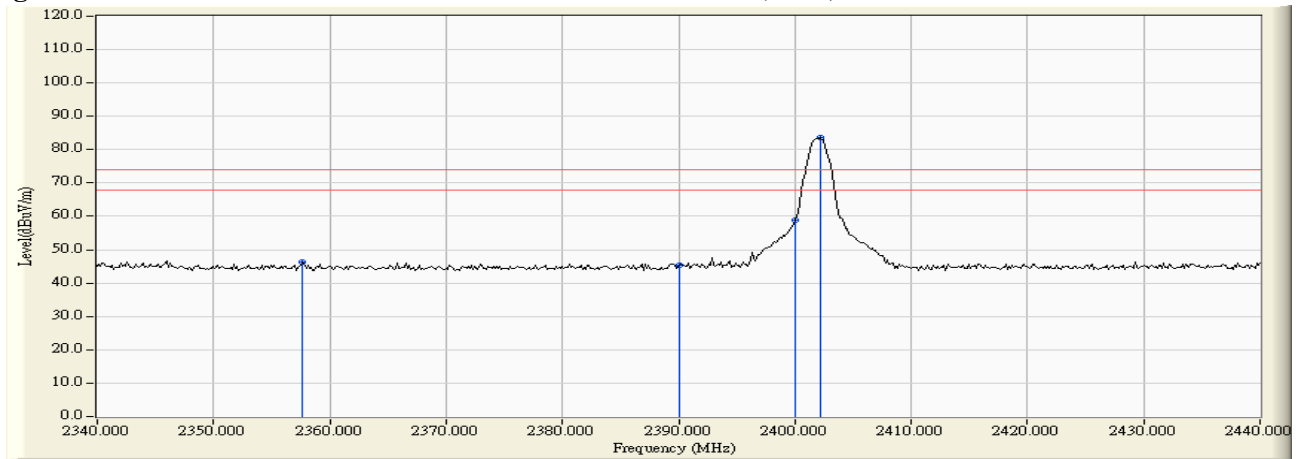
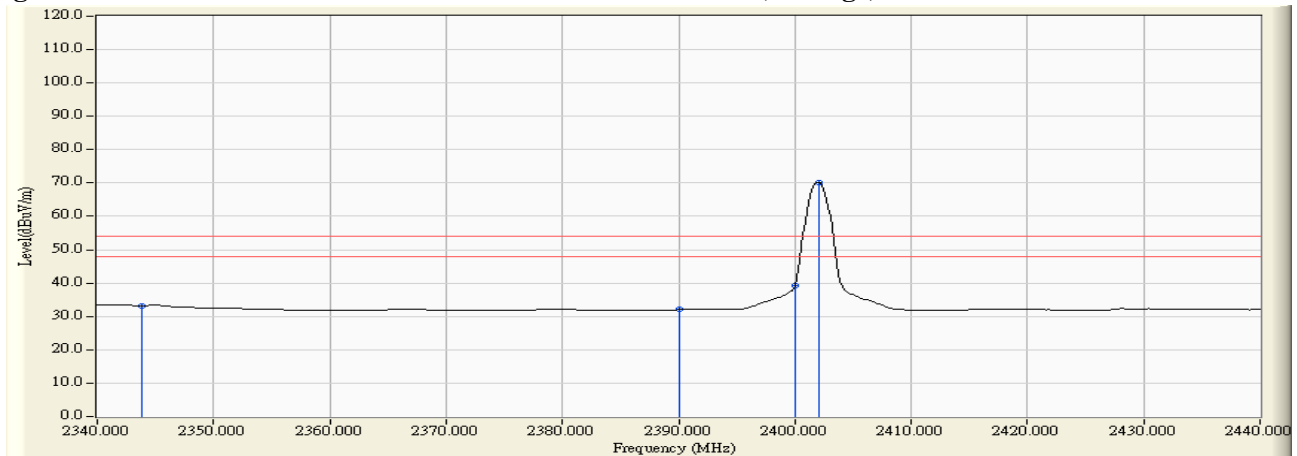

Figure Channel 00: VERTICAL (Average)



Note:

1. All readings above 1GHz are performed with peak and/or average measurements as necessary.
2. Peak measurements: RBW = 1MHz, VBW = 3 MHz, Sweep: Auto.
3. Average measurements: RBW = 1MHz, VBW = 10 Hz, Sweep: Auto.
4. “ * ”, means this data is the worst emission level.
5. Measurement Level = Reading Level + Correction Factor.
6. The average measurement was not performed when the peak measured data is under the limit of average detection.

Product : Medical Cart Computer
 Test Item : Band Edge
 Test Site : No.3 OATS
 Test Mode : Mode 1: Transmit - 1Mbps (GFSK) (2480MHz) (22")

RF Radiated Measurement (Horizontal):

Channel No.	Frequency (MHz)	Correct Factor (dB)	Reading Level (dBμV)	Emission Level (dBμV/m)	Peak Limit (dBμV/m)	Average Limit (dBμV/m)	Result
78 (Peak)	2479.877	-0.581	95.137	94.556	--	--	--
78 (Peak)	2483.500	-0.558	62.297	61.739	74.00	54.00	Pass
78 (Average)	2480.022	-0.580	92.250	91.670	--	--	--
78 (Average)	2483.500	-0.558	49.568	49.010	74.00	54.00	Pass

Figure Channel 78: Horizontal (Peak)

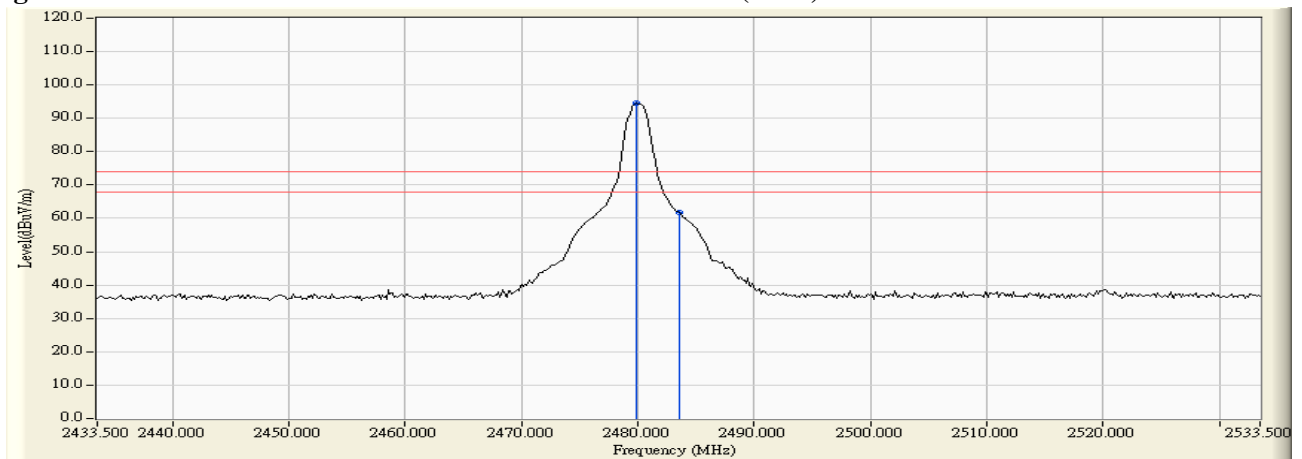
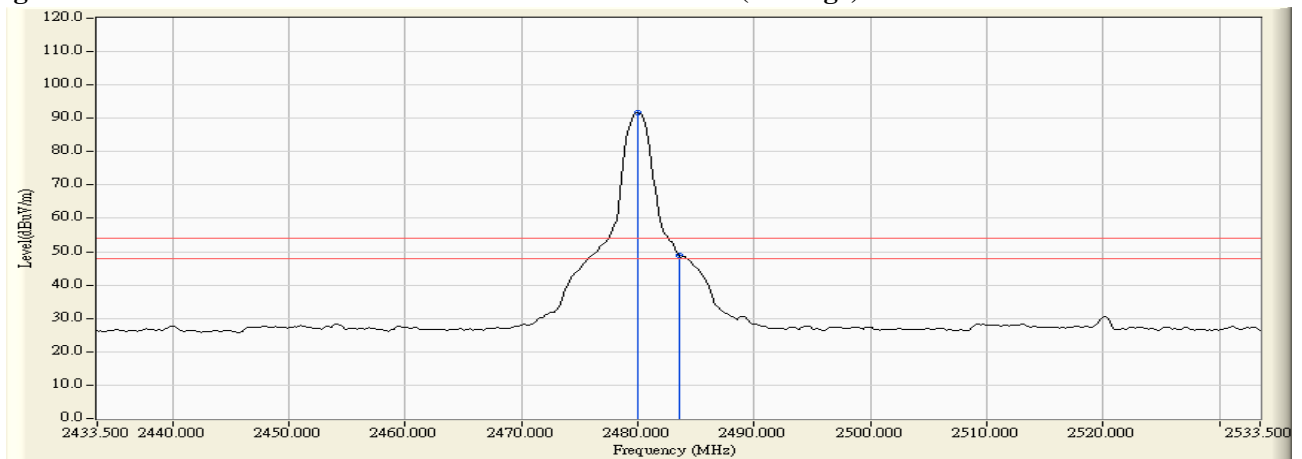

Figure Channel 78: Horizontal (Average)



Note:

1. All readings above 1GHz are performed with peak and/or average measurements as necessary.
2. Peak measurements: RBW = 1MHz, VBW = 3 MHz, Sweep: Auto.
3. Average measurements: RBW = 1MHz, VBW = 10 Hz, Sweep: Auto.
4. “ * ”, means this data is the worst emission level.
5. Measurement Level = Reading Level + Correction Factor.
6. The average measurement was not performed when the peak measured data is under the limit of average detection.

Product : Medical Cart Computer
 Test Item : Band Edge
 Test Site : No.3 OATS
 Test Mode : Mode 1: Transmit - 1Mbps (GFSK) (2480MHz) (22'')

RF Radiated Measurement (VERTICAL):

Channel No.	Frequency (MHz)	Correct Factor (dB)	Reading Level (dBμV)	Emission Level (dBμV/m)	Peak Limit (dBμV/m)	Average Limit (dBμV/m)	Result
78 (Peak)	2480.022	-1.324	92.150	90.826	--	--	--
78 (Peak)	2483.500	-1.305	59.495	58.190	74.00	54.00	Pass
78 (Average)	2480.022	-1.324	74.249	72.925	--	--	--
78 (Average)	2483.500	-1.305	34.670	33.365	74.00	54.00	Pass

Figure Channel 78: VERTICAL (Peak)

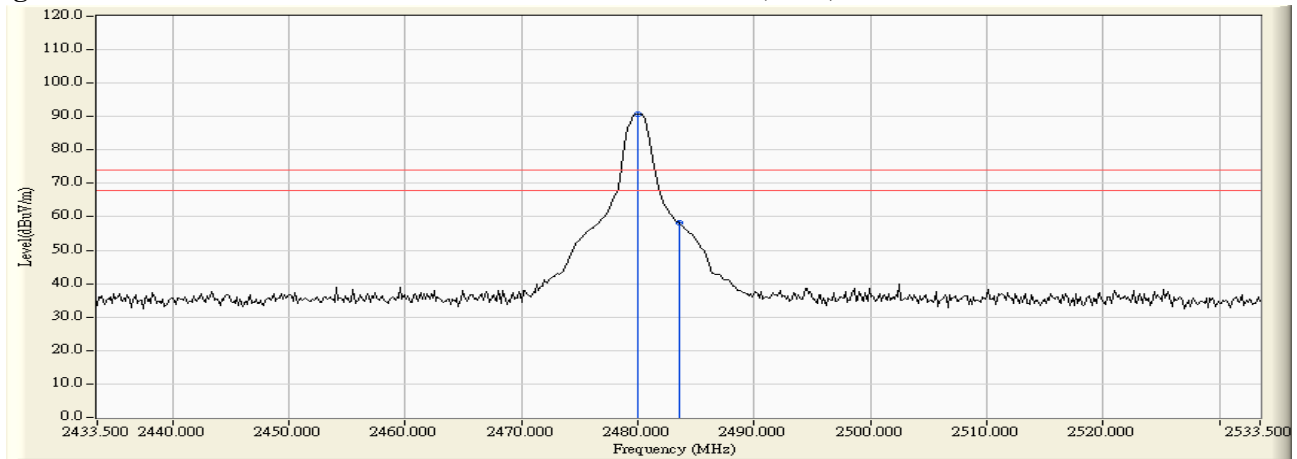
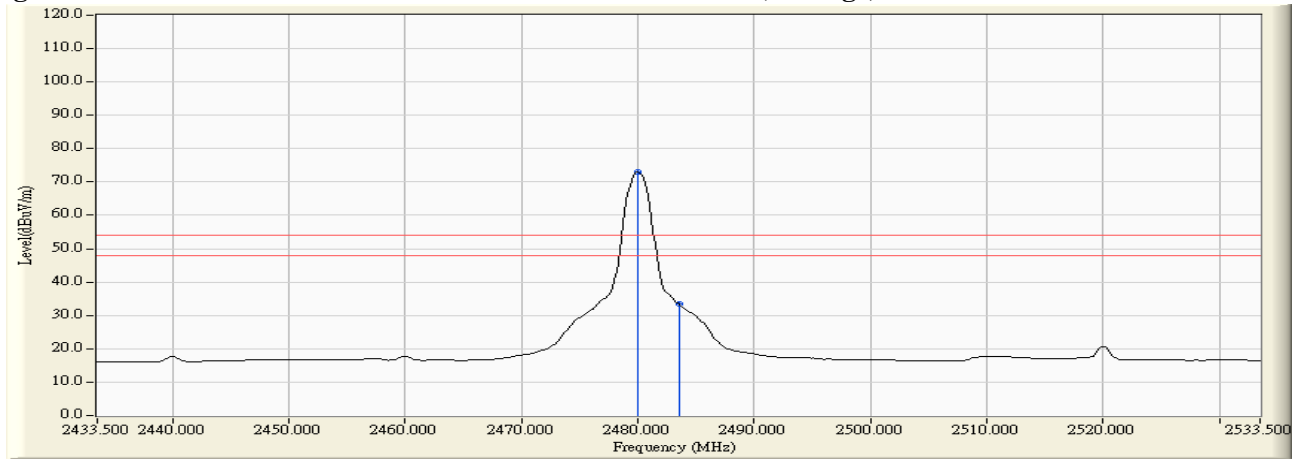

Figure Channel 78: VERTICAL (Average)



Note:

1. All readings above 1GHz are performed with peak and/or average measurements as necessary.
2. Peak measurements: RBW = 1MHz, VBW = 3 MHz, Sweep: Auto.
3. Average measurements: RBW = 1MHz, VBW = 10 Hz, Sweep: Auto.
4. “ * ”, means this data is the worst emission level.
5. Measurement Level = Reading Level + Correction Factor.
6. The average measurement was not performed when the peak measured data is under the limit of average detection.

Product : Medical Cart Computer
 Test Item : Band Edge
 Test Site : No.3 OATS
 Test Mode : Mode 2: Transmit - 3Mbps (8DPSK) (2402MHz) (22")

RF Radiated Measurement (Horizontal):

Channel No.	Frequency (MHz)	Correct Factor (dB)	Reading Level (dBμV)	Emission Level (dBμV/m)	Peak Limit (dBμV/m)	Average Limit (dBμV/m)	Result
00 (Peak)	2376.957	-1.181	47.834	46.652	74.00	54.00	Pass
00 (Peak)	2390.000	-1.131	46.338	45.207	74.00	54.00	Pass
00 (Peak)	2400.000	-1.084	63.566	62.483	--	--	--
00 (Peak)	2401.739	-1.074	86.981	85.907	--	--	--
00 (Average)	2344.928	-1.307	34.728	33.421	74.00	54.00	Pass
00 (Average)	2390.000	-1.131	33.674	32.543	74.00	54.00	Pass
00 (Average)	2400.000	-1.084	46.017	44.934	--	--	--
00 (Average)	2402.029	-1.073	72.372	71.300	--	--	--

Figure Channel 00: Horizontal (Peak)

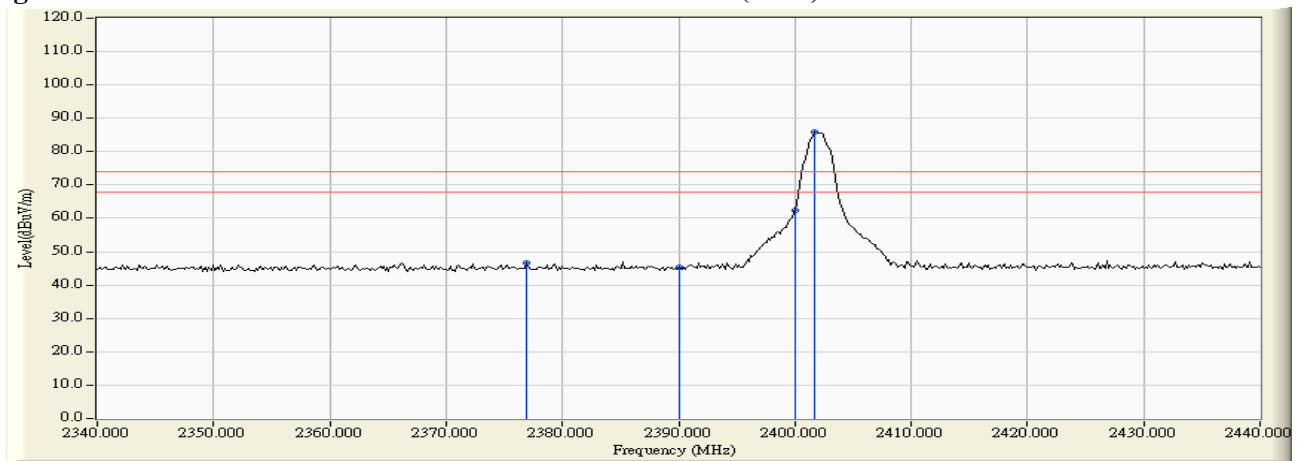
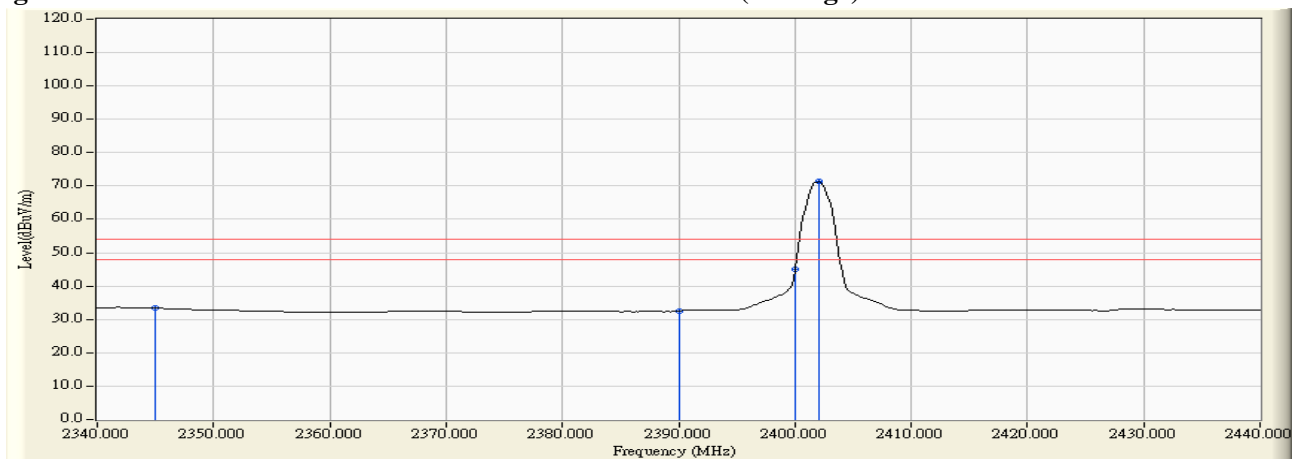

Figure Channel 00: Horizontal (Average)



Note:

1. All readings above 1GHz are performed with peak and/or average measurements as necessary.
2. Peak measurements: RBW = 1MHz, VBW = 3 MHz, Sweep: Auto.
3. Average measurements: RBW = 1MHz, VBW = 10 Hz, Sweep: Auto.
4. “ * ”, means this data is the worst emission level.
5. Measurement Level = Reading Level + Correction Factor.
6. The average measurement was not performed when the peak measured data is under the limit of average detection.

Product : Medical Cart Computer
 Test Item : Band Edge
 Test Site : No.3 OATS
 Test Mode : Mode 2: Transmit - 3Mbps (8DPSK) (2402MHz) (22")

RF Radiated Measurement (VERTICAL):

Channel No.	Frequency (MHz)	Correct Factor (dB)	Reading Level (dBμV)	Emission Level (dBμV/m)	Peak Limit (dBμV/m)	Average Limit (dBμV/m)	Result
00 (Peak)	2367.391	-1.620	49.028	47.408	74.00	54.00	Pass
00 (Peak)	2390.000	-1.725	48.679	46.954	74.00	54.00	Pass
00 (Peak)	2400.000	-1.733	59.119	57.387	--	--	--
00 (Peak)	2402.174	-1.729	81.897	80.169	--	--	--
00 (Average)	2342.609	-1.505	34.941	33.436	74.00	54.00	Pass
00 (Average)	2390.000	-1.725	33.988	32.263	74.00	54.00	Pass
00 (Average)	2400.000	-1.733	42.065	40.333	--	--	--
00 (Average)	2402.029	-1.729	67.624	65.895	--	--	--

Figure Channel 00: VERTICAL (Peak)

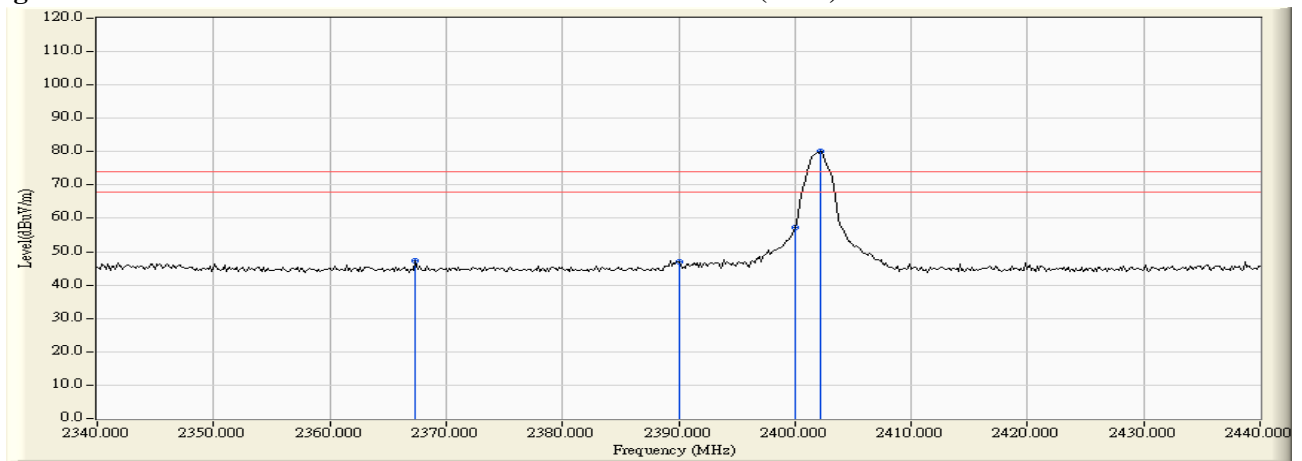
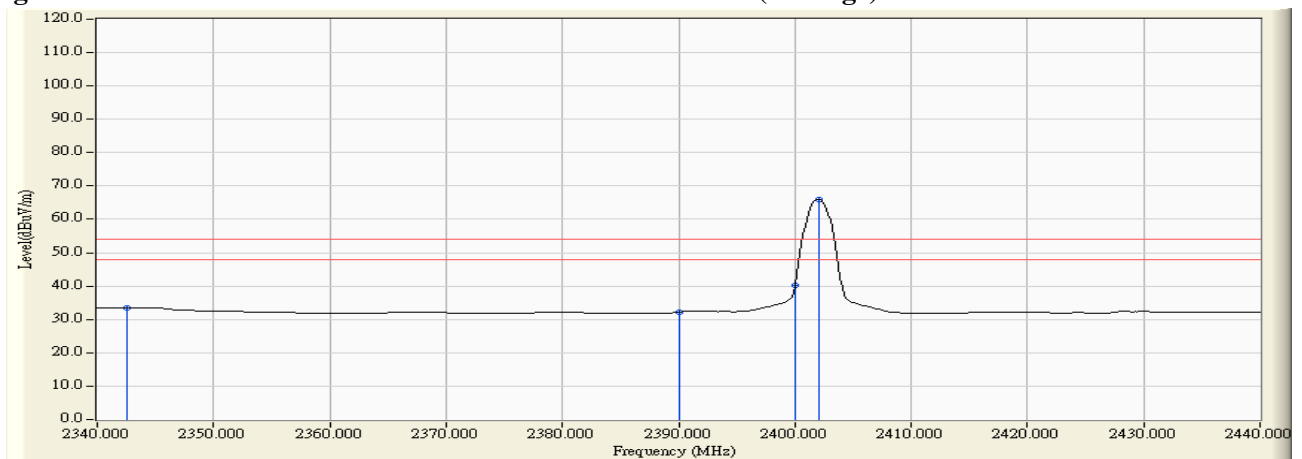

Figure Channel 00: VERTICAL (Average)



Note:

1. All readings above 1GHz are performed with peak and/or average measurements as necessary.
2. Peak measurements: RBW = 1MHz, VBW = 3 MHz, Sweep: Auto.
3. Average measurements: RBW = 1MHz, VBW = 10 Hz, Sweep: Auto.
4. “ * ”, means this data is the worst emission level.
5. Measurement Level = Reading Level + Correction Factor.
6. The average measurement was not performed when the peak measured data is under the limit of average detection.

Product : Medical Cart Computer
 Test Item : Band Edge
 Test Site : No.3 OATS
 Test Mode : Mode 2: Transmit - 3Mbps (8DPSK) (2480MHz) (22")

RF Radiated Measurement (Horizontal):

Channel No.	Frequency (MHz)	Correct Factor (dB)	Reading Level (dBμV)	Emission Level (dBμV/m)	Peak Limit (dBμV/m)	Average Limit (dBμV/m)	Result
78 (Peak)	2479.732	-0.582	92.127	91.545	--	--	--
78 (Peak)	2483.500	-0.558	60.745	60.187	74.00	54.00	Pass
78 (Average)	2480.022	-0.580	73.052	72.472	--	--	--
78 (Average)	2483.500	-0.558	34.606	34.048	74.00	54.00	Pass

Figure Channel 00: Horizontal (Peak)

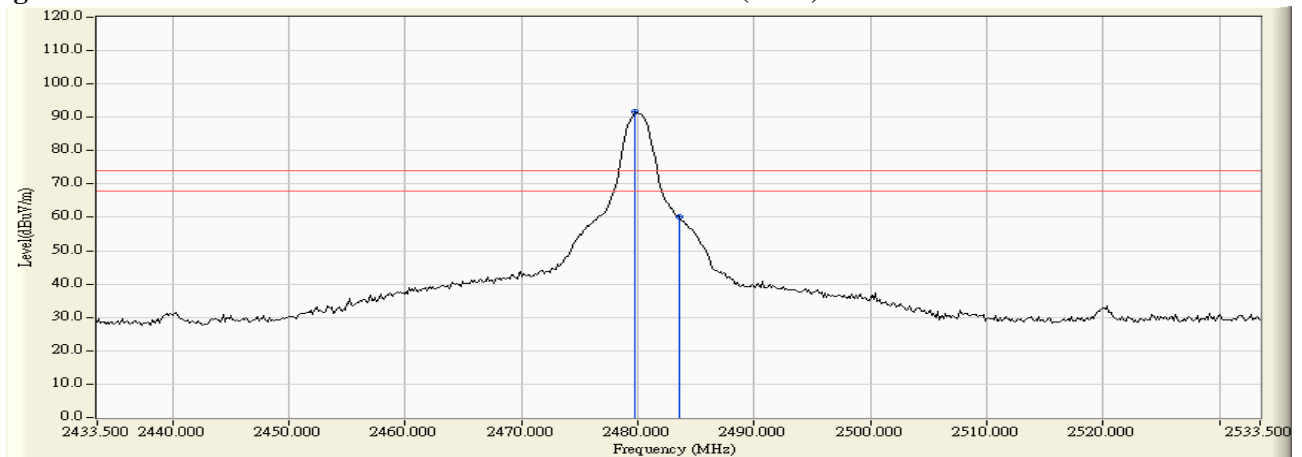
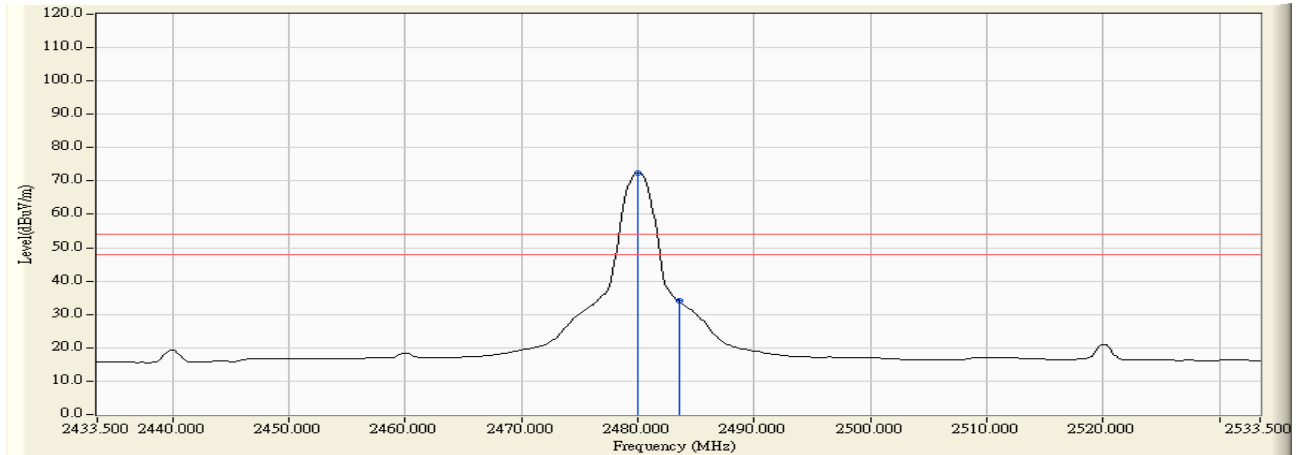

Figure Channel 00: Horizontal (Average)



Note:

1. All readings above 1GHz are performed with peak and/or average measurements as necessary.
2. Peak measurements: RBW = 1MHz, VBW = 3 MHz, Sweep: Auto.
3. Average measurements: RBW = 1MHz, VBW = 10 Hz, Sweep: Auto.
4. “*”, means this data is the worst emission level.
5. Measurement Level = Reading Level + Correction Factor.
6. The average measurement was not performed when the peak measured data is under the limit of average detection.

Product : Medical Cart Computer
 Test Item : Band Edge
 Test Site : No.3 OATS
 Test Mode : Mode 2: Transmit - 3Mbps (8DPSK) (2480MHz) (22")

RF Radiated Measurement (VERTICAL):

Channel No.	Frequency (MHz)	Correct Factor (dB)	Reading Level (dBμV)	Emission Level (dBμV/m)	Peak Limit (dBμV/m)	Average Limit (dBμV/m)	Result
78 (Peak)	2480.022	-1.324	89.368	88.044	--	--	--
78 (Peak)	2483.500	-1.305	58.019	56.714	74.00	54.00	Pass
78 (Average)	2480.022	-1.324	70.741	69.417	--	--	--
78 (Average)	2483.500	-1.305	33.007	31.702	74.00	54.00	Pass

Figure Channel 78: VERTICAL (Peak)

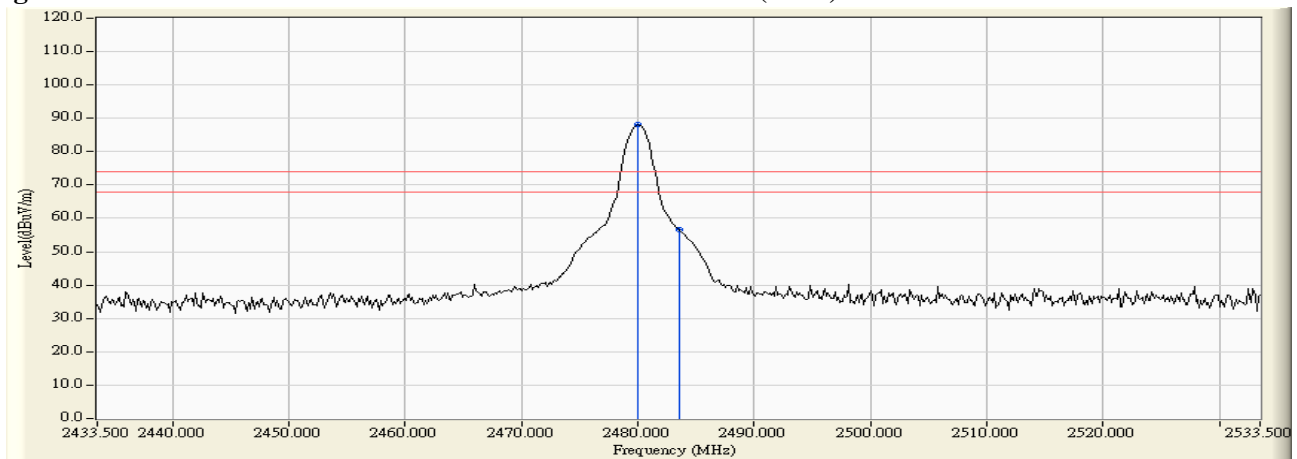
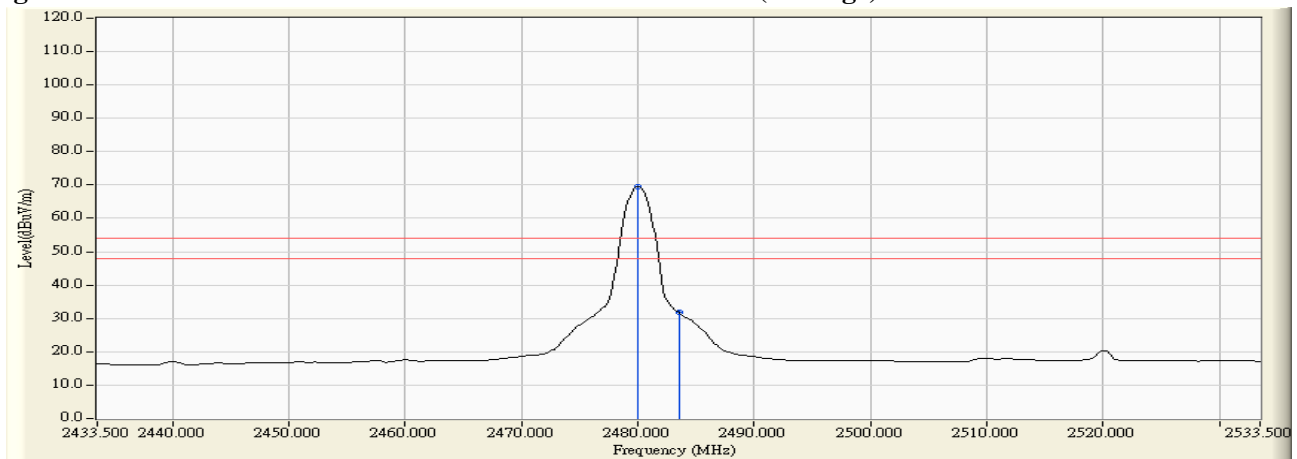

Figure Channel 78: VERTICAL (Average)



Note:

1. All readings above 1GHz are performed with peak and/or average measurements as necessary.
2. Peak measurements: RBW = 1MHz, VBW = 3 MHz, Sweep: Auto.
3. Average measurements: RBW = 1MHz, VBW = 10 Hz, Sweep: Auto.
4. “ * ”, means this data is the worst emission level.
5. Measurement Level = Reading Level + Correction Factor.
6. The average measurement was not performed when the peak measured data is under the limit of average detection.

Product : Medical Cart Computer
 Test Item : Band Edge
 Test Site : No.3 OATS
 Test Mode : Mode 1: Transmit - 1Mbps (GFSK) (2402MHz) (Hopping Bandedge) (22")

RF Radiated Measurement (Horizontal):

Channel No.	Frequency (MHz)	Correct Factor (dB)	Reading Level (dBμV)	Emission Level (dBμV/m)	Peak Limit (dBμV/m)	Average Limit (dBμV/m)	Result
00 (Peak)	2382.609	-1.159	48.990	47.830	74.00	54.00	Pass
00 (Peak)	2390.000	-1.131	47.421	46.290	74.00	54.00	Pass
00 (Peak)	2400.000	-1.084	65.698	64.615	--	--	--
00 (Peak)	2439.130	-0.841	94.031	93.190	--	--	--
00 (Average)	2375.652	-1.186	37.149	35.962	74.00	54.00	Pass
00 (Average)	2390.000	-1.131	35.844	34.713	74.00	54.00	Pass
00 (Average)	2400.000	-1.084	53.402	52.319	--	--	--
00 (Average)	2440.000	-0.836	91.368	90.532	--	--	--

Figure Channel 00: Horizontal (Peak)

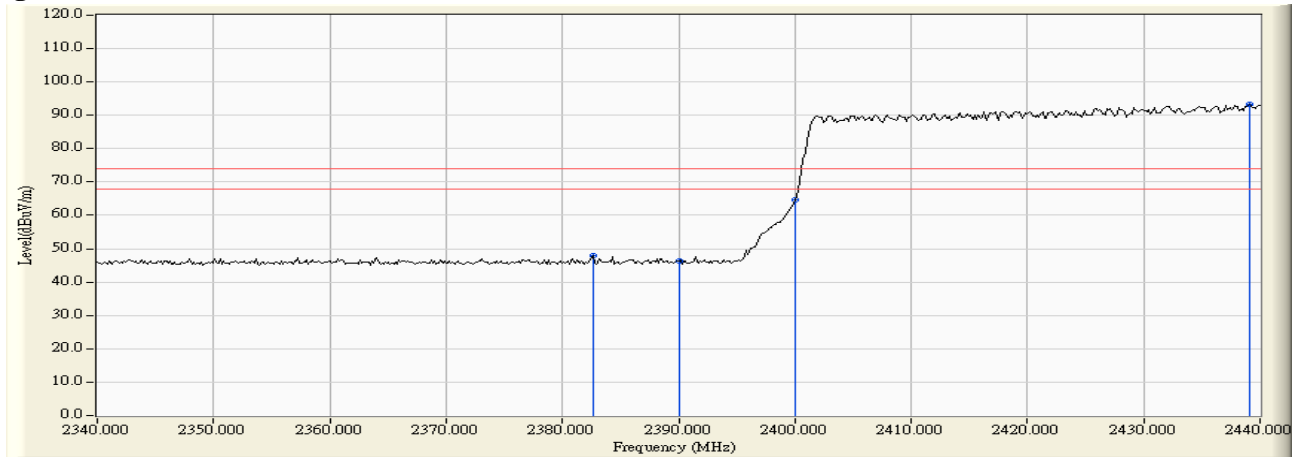
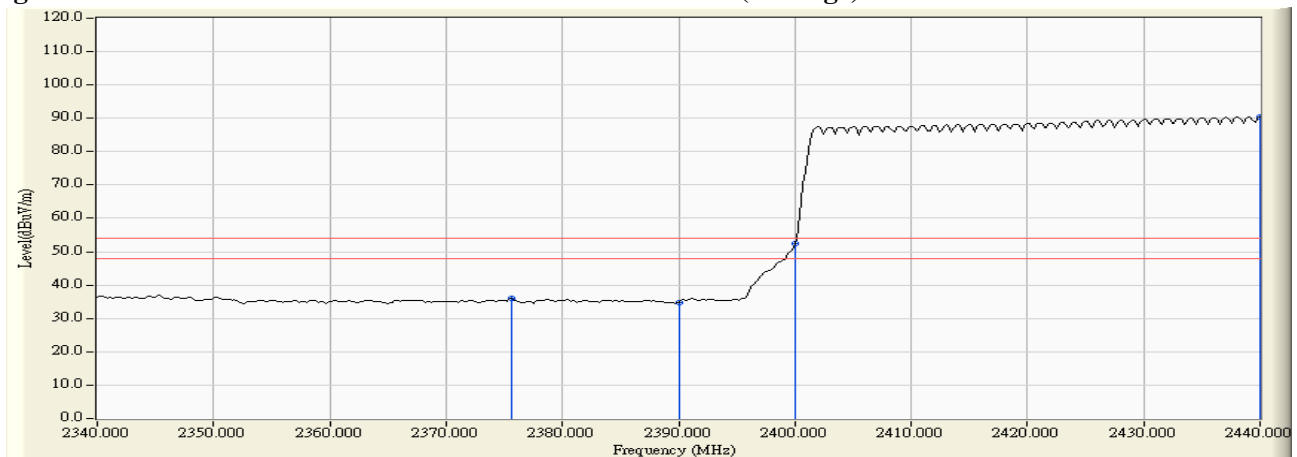

Figure Channel 00: Horizontal (Average)



Note:

1. All readings above 1GHz are performed with peak and/or average measurements as necessary.
2. Peak measurements: RBW = 1MHz, VBW = 3 MHz, Sweep: Auto.
3. Average measurements: RBW = 1MHz, VBW = 10 Hz, Sweep: Auto.
4. “ * ”, means this data is the worst emission level.
5. Measurement Level = Reading Level + Correction Factor.
6. The average measurement was not performed when the peak measured data is under the limit of average detection.

Product : Medical Cart Computer
 Test Item : Band Edge
 Test Site : No.3 OATS
 Test Mode : Mode 1: Transmit - 1Mbps (GFSK) (2402MHz) (Hopping Bandedge) (22'')

RF Radiated Measurement (VERTICAL):

Channel No.	Frequency (MHz)	Correct Factor (dB)	Reading Level (dBμV)	Emission Level (dBμV/m)	Peak Limit (dBμV/m)	Average Limit (dBμV/m)	Result
00 (Peak)	2383.333	-1.694	48.680	46.986	74.00	54.00	Pass
00 (Peak)	2390.000	-1.725	47.690	45.965	74.00	54.00	Pass
00 (Peak)	2400.000	-1.733	60.684	58.952	--	--	--
00 (Peak)	2436.087	-1.570	88.327	86.756	--	--	--
00 (Average)	2389.275	-1.721	37.345	35.624	74.00	54.00	Pass
00 (Average)	2390.000	-1.725	35.724	33.999	74.00	54.00	Pass
00 (Average)	2400.000	-1.733	48.258	46.526	--	--	--
00 (Average)	2440.000	-1.549	85.815	84.266	--	--	--

Figure Channel 00: VERTICAL (Peak)

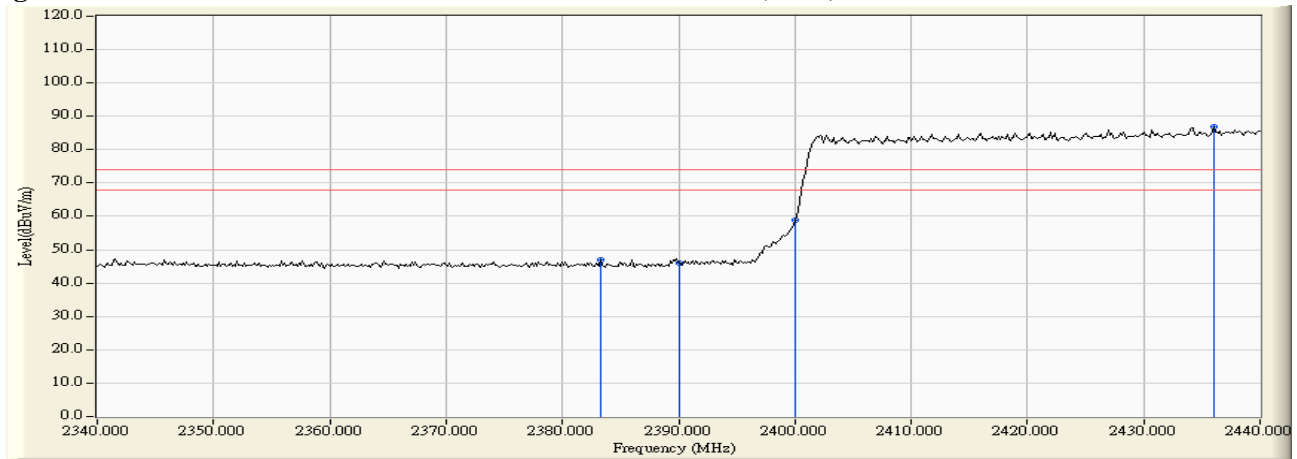
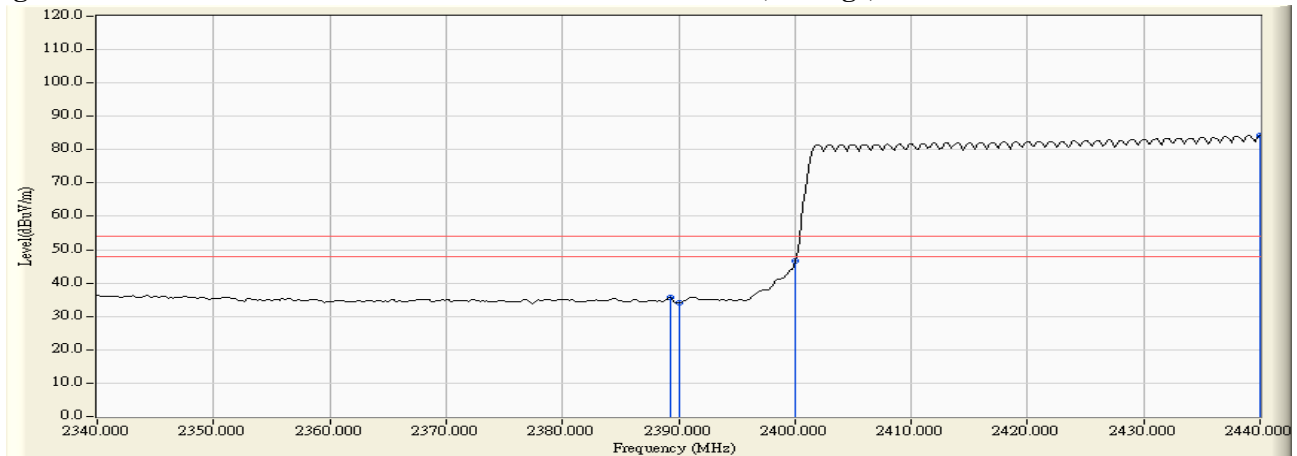

Figure Channel 00: VERTICAL (Average)



Note:

1. All readings above 1GHz are performed with peak and/or average measurements as necessary.
2. Peak measurements: RBW = 1MHz, VBW = 3 MHz, Sweep: Auto.
3. Average measurements: RBW = 1MHz, VBW = 10 Hz, Sweep: Auto.
4. “ * ”, means this data is the worst emission level.
5. Measurement Level = Reading Level + Correction Factor.
6. The average measurement was not performed when the peak measured data is under the limit of average detection.

Product : Medical Cart Computer
 Test Item : Band Edge
 Test Site : No.3 OATS
 Test Mode : Mode 1: Transmit - 1Mbps (GFSK) (2480MHz) (Hopping Bandedge) (22'')

RF Radiated Measurement (Horizontal):

Channel No.	Frequency (MHz)	Correct Factor (dB)	Reading Level (dBμV)	Emission Level (dBμV/m)	Peak Limit (dBμV/m)	Average Limit (dBμV/m)	Result
78 (Peak)	2471.906	-0.632	94.736	94.104	--	--	--
78 (Peak)	2483.500	-0.558	61.177	60.619	74.00	54.00	Pass
78 (Average)	2469.007	-0.651	91.945	91.295	--	--	--
78 (Average)	2483.500	-0.558	47.198	46.640	74.00	54.00	Pass

Figure Channel 78: Horizontal (Peak)

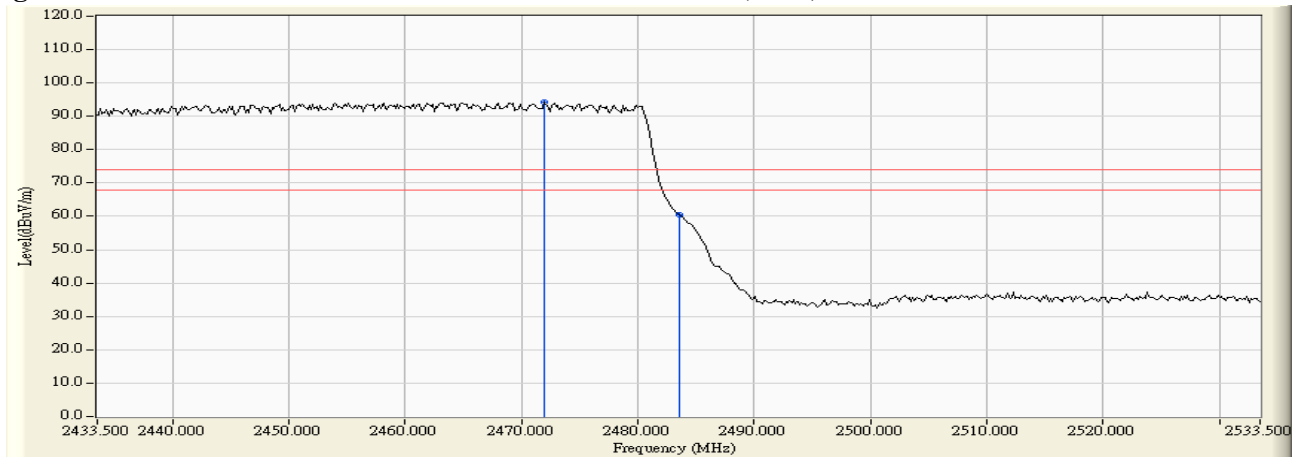
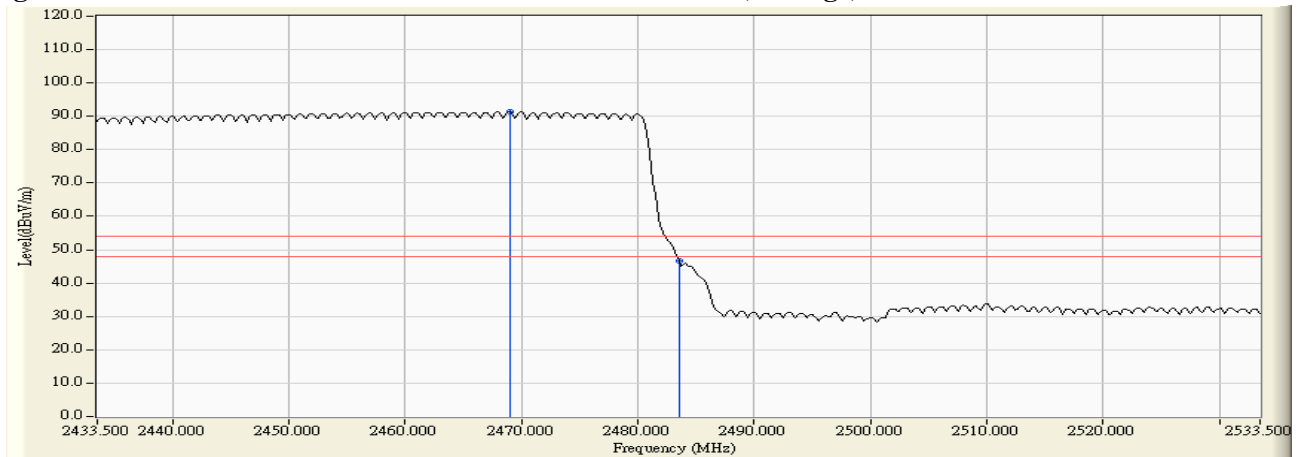

Figure Channel 78: Horizontal (Average)



Note:

1. All readings above 1GHz are performed with peak and/or average measurements as necessary.
2. Peak measurements: RBW = 1MHz, VBW = 3 MHz, Sweep: Auto.
3. Average measurements: RBW = 1MHz, VBW = 10 Hz, Sweep: Auto.
4. “ * ”, means this data is the worst emission level.
5. Measurement Level = Reading Level + Correction Factor.
6. The average measurement was not performed when the peak measured data is under the limit of average detection.

Product : Medical Cart Computer
 Test Item : Band Edge
 Test Site : No.3 OATS
 Test Mode : Mode 1: Transmit - 1Mbps (GFSK) (2480MHz) (Hopping Bandedge) (22")

RF Radiated Measurement (VERTICAL):

Channel No.	Frequency (MHz)	Correct Factor (dB)	Reading Level (dBμV)	Emission Level (dBμV/m)	Peak Limit (dBμV/m)	Average Limit (dBμV/m)	Result
78 (Peak)	2474.080	-1.358	92.288	90.931	--	--	Pass
78 (Peak)	2483.500	-1.305	59.426	58.121	74.00	54.00	Pass
78 (Average)	2472.920	-1.364	89.913	88.549	--	--	Pass
78 (Average)	2483.500	-1.305	43.854	42.549	74.00	54.00	Pass

Figure Channel 78: VERTICAL (Peak)

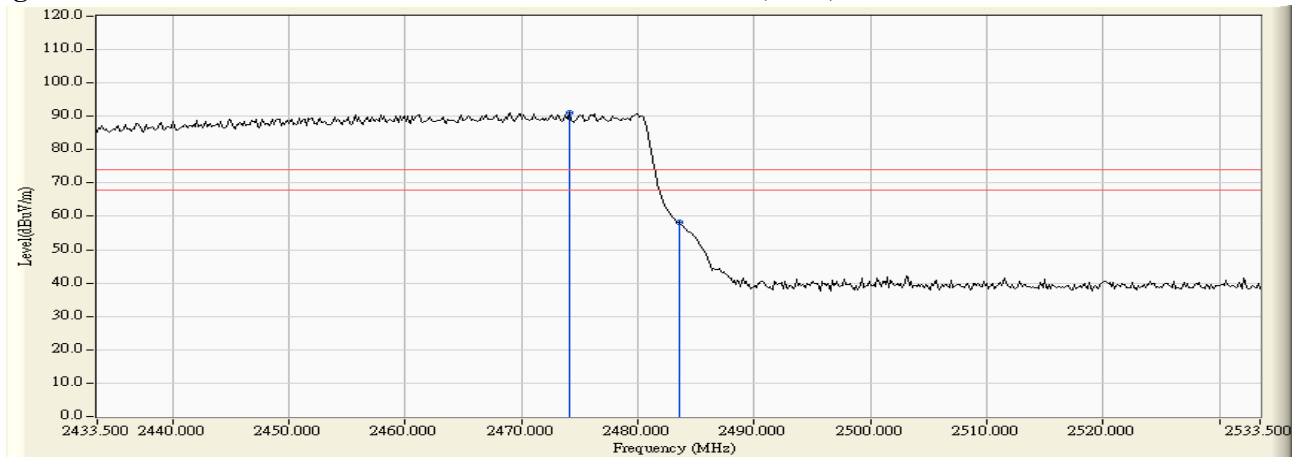
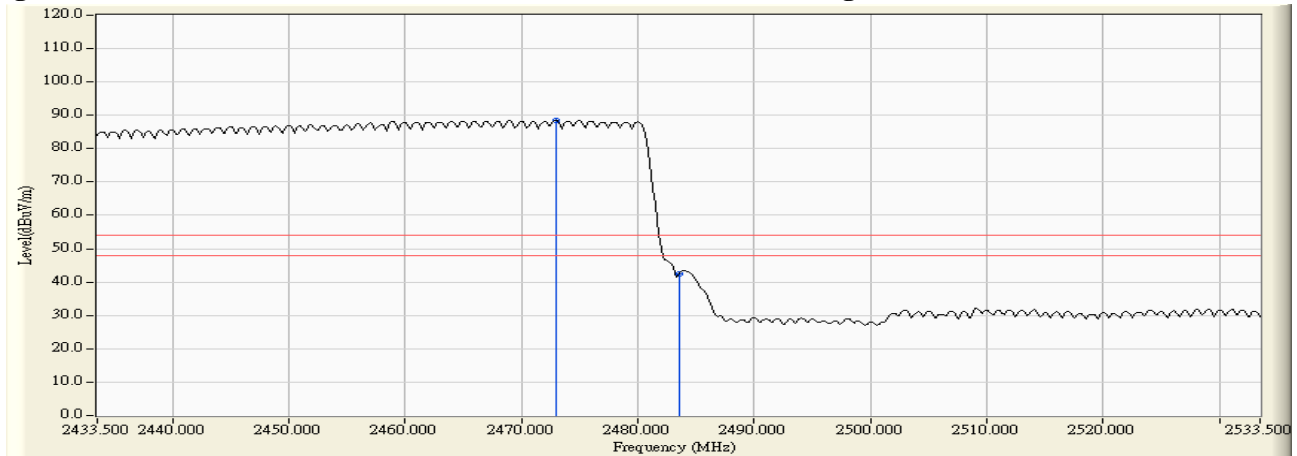

Figure Channel 78: VERTICAL (Average)



Note:

1. All readings above 1GHz are performed with peak and/or average measurements as necessary.
2. Peak measurements: RBW = 1MHz, VBW = 3 MHz, Sweep: Auto.
3. Average measurements: RBW = 1MHz, VBW = 10 Hz, Sweep: Auto.
4. “ * ”, means this data is the worst emission level.
5. Measurement Level = Reading Level + Correction Factor.
6. The average measurement was not performed when the peak measured data is under the limit of average detection.

Product : Medical Cart Computer
 Test Item : Band Edge
 Test Site : No.3 OATS
 Test Mode : Mode 2: Transmit - 3Mbps (8DPSK) (2402MHz) (Hopping Bandedge) (22")

RF Radiated Measurement (Horizontal):

Channel No.	Frequency (MHz)	Correct Factor (dB)	Reading Level (dBμV)	Emission Level (dBμV/m)	Peak Limit (dBμV/m)	Average Limit (dBμV/m)	Result
00 (Peak)	2383.333	-1.157	48.524	47.367	74.00	54.00	Pass
00 (Peak)	2390.000	-1.131	47.606	46.475	74.00	54.00	Pass
00 (Peak)	2400.000	-1.084	63.151	62.068	--	--	--
00 (Peak)	2436.957	-0.856	89.615	88.760	--	--	--
00 (Average)	2354.058	-1.272	37.289	36.017	74.00	54.00	Pass
00 (Average)	2390.000	-1.131	35.706	34.575	74.00	54.00	Pass
00 (Average)	2400.000	-1.084	52.188	51.105	--	--	--
00 (Average)	2440.000	-0.836	86.972	86.136	--	--	--

Figure Channel 00: Horizontal (Peak)

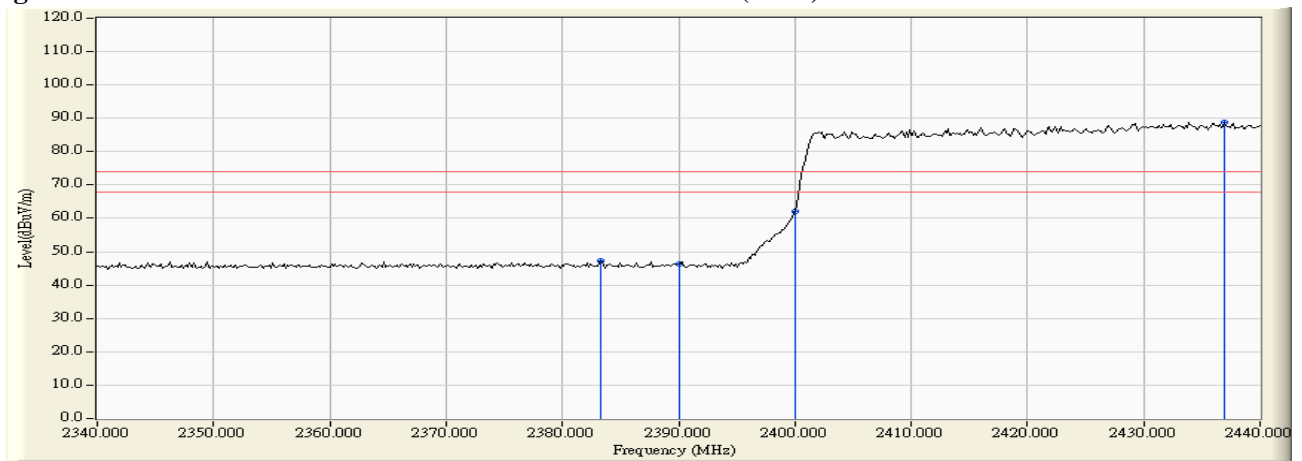
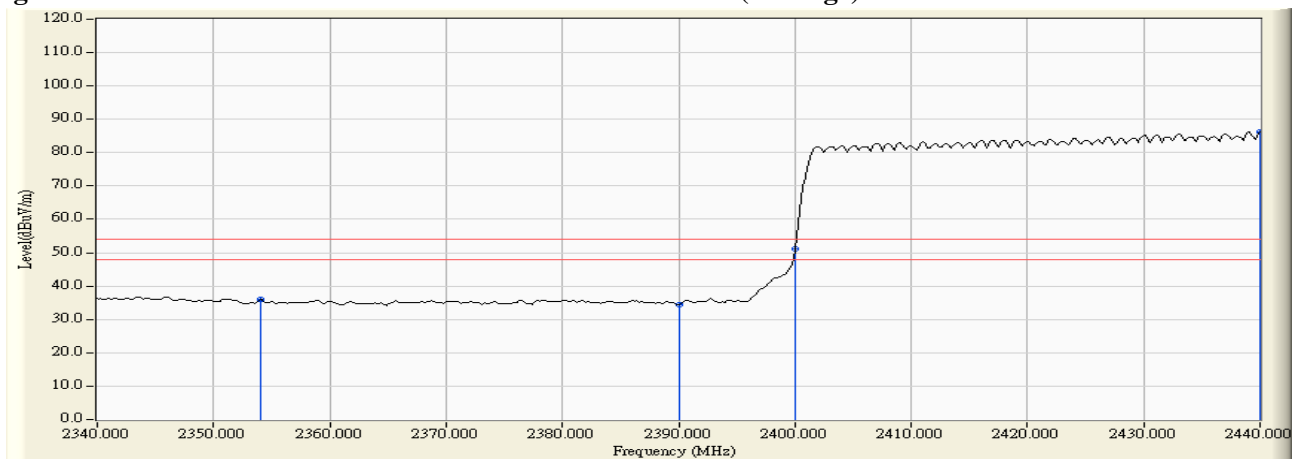

Figure Channel 00: Horizontal (Average)



Note:

1. All readings above 1GHz are performed with peak and/or average measurements as necessary.
2. Peak measurements: RBW = 1MHz, VBW = 3 MHz, Sweep: Auto.
3. Average measurements: RBW = 1MHz, VBW = 10 Hz, Sweep: Auto.
4. “ * ”, means this data is the worst emission level.
5. Measurement Level = Reading Level + Correction Factor.
6. The average measurement was not performed when the peak measured data is under the limit of average detection.

Product : Medical Cart Computer
 Test Item : Band Edge
 Test Site : No.3 OATS
 Test Mode : Mode 2: Transmit - 3Mbps (8DPSK) (2402MHz) (Hopping Bandedge) (22")

RF Radiated Measurement (VERTICAL):

Channel No.	Frequency (MHz)	Correct Factor (dB)	Reading Level (dBμV)	Emission Level (dBμV/m)	Peak Limit (dBμV/m)	Average Limit (dBμV/m)	Result
00 (Peak)	2390.000	-1.725	49.671	47.946	74.00	54.00	Pass
00 (Peak)	2400.000	-1.733	58.514	56.782	--	--	--
00 (Peak)	2436.232	-1.570	85.246	83.676	--	--	--
00 (Average)	2345.507	-1.519	37.866	36.348	74.00	54.00	Pass
00 (Average)	2390.000	-1.725	36.107	34.382	74.00	54.00	Pass
00 (Average)	2400.000	-1.733	47.156	45.424	--	--	--
00 (Average)	2437.971	-1.560	81.715	80.155	--	--	--

Figure Channel 00: VERTICAL (Peak)

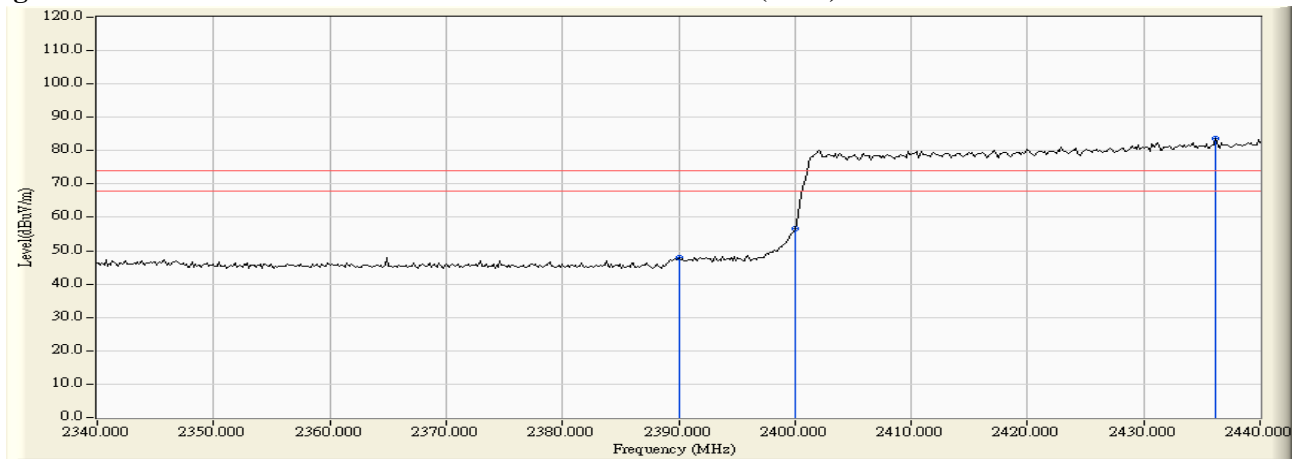
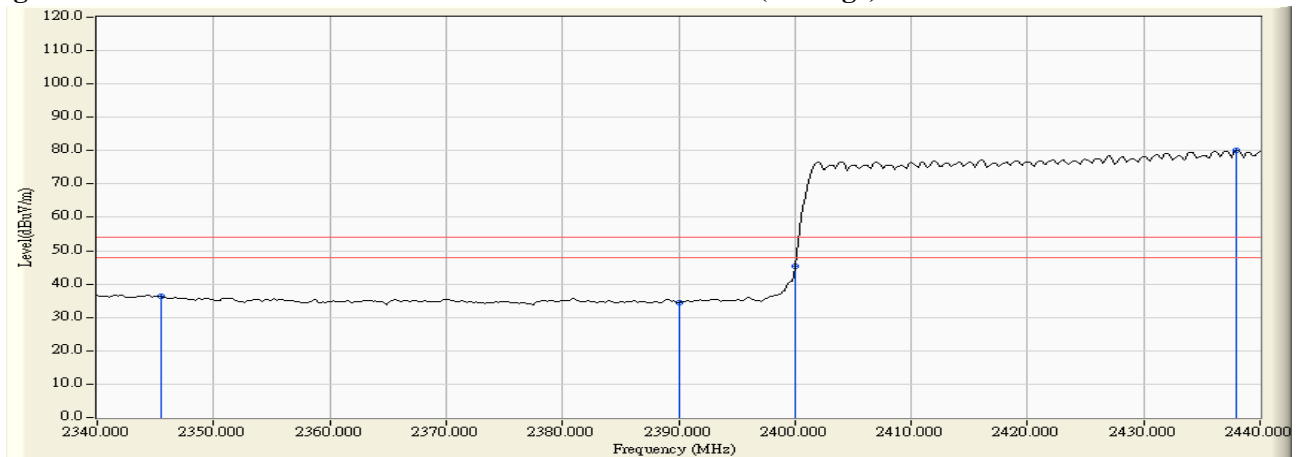

Figure Channel 00: VERTICAL (Average)



Note:

1. All readings above 1GHz are performed with peak and/or average measurements as necessary.
2. Peak measurements: RBW = 1MHz, VBW = 3 MHz, Sweep: Auto.
3. Average measurements: RBW = 1MHz, VBW = 10 Hz, Sweep: Auto.
4. “ * ”, means this data is the worst emission level.
5. Measurement Level = Reading Level + Correction Factor.
6. The average measurement was not performed when the peak measured data is under the limit of average detection.

Product : Medical Cart Computer
 Test Item : Band Edge
 Test Site : No.3 OATS
 Test Mode : Mode 2: Transmit - 3Mbps (8DPSK) (2480MHz) (Hopping Bandedge) (22")

RF Radiated Measurement (Horizontal):

Channel No.	Frequency (MHz)	Correct Factor (dB)	Reading Level (dBμV)	Emission Level (dBμV/m)	Peak Limit (dBμV/m)	Average Limit (dBμV/m)	Result
78 (Peak)	2471.906	-0.632	92.319	91.687	--	--	Pass
78 (Peak)	2483.500	-0.558	60.426	59.868	74.00	54.00	Pass
78 (Average)	2466.978	-0.664	88.444	87.781	--	--	Pass
78 (Average)	2483.500	-0.558	40.735	40.177	74.00	54.00	Pass
78 (Average)	2483.935	-0.555	42.940	42.385	74.00	54.00	Pass

Figure Channel 00: Horizontal (Peak)

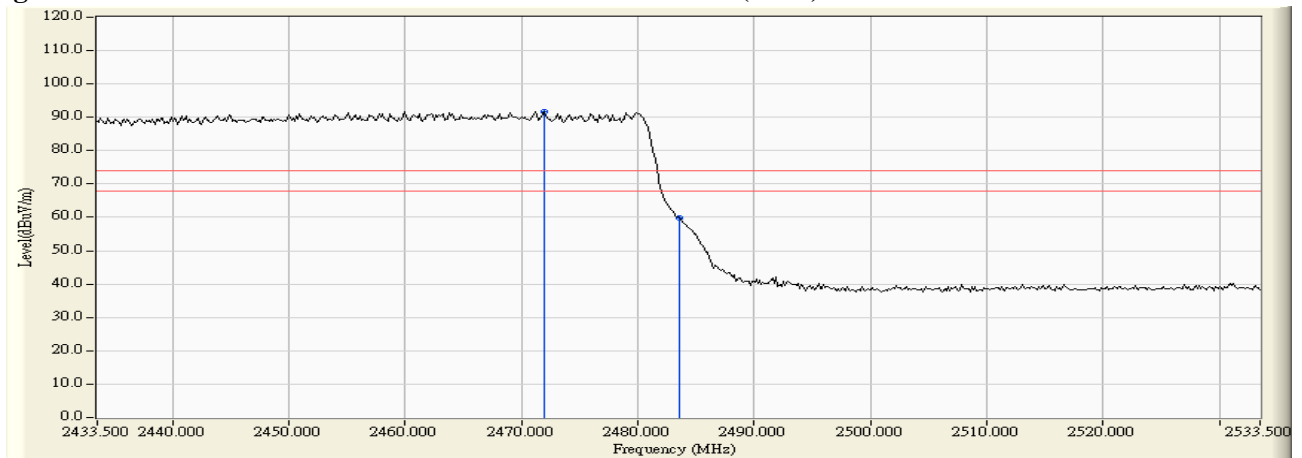
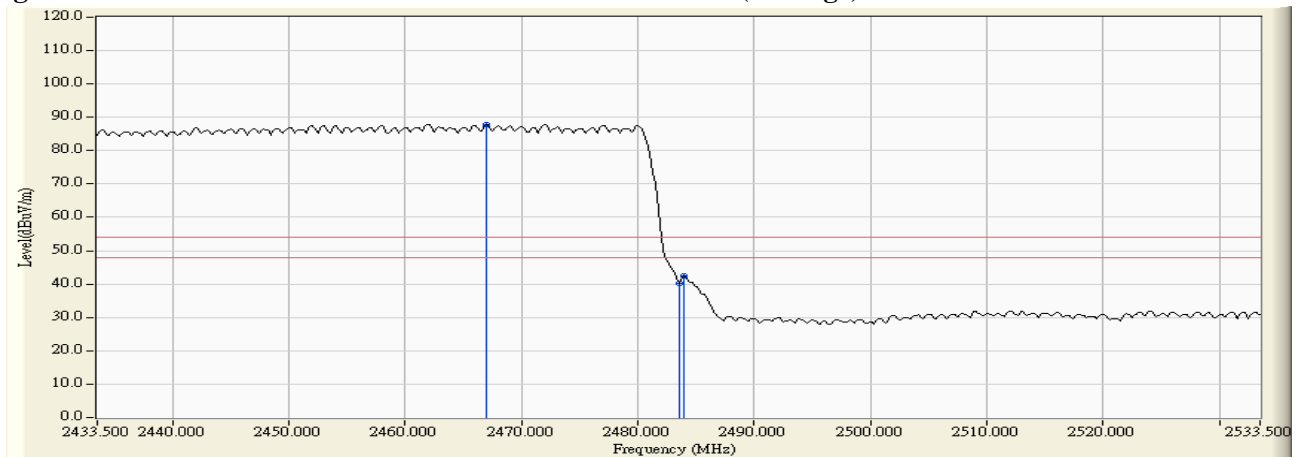

Figure Channel 00: Horizontal (Average)



Note:

1. All readings above 1GHz are performed with peak and/or average measurements as necessary.
2. Peak measurements: RBW = 1MHz, VBW = 3 MHz, Sweep: Auto.
3. Average measurements: RBW = 1MHz, VBW = 10 Hz, Sweep: Auto.
4. “ * ”, means this data is the worst emission level.
5. Measurement Level = Reading Level + Correction Factor.
6. The average measurement was not performed when the peak measured data is under the limit of average detection.

Product : Medical Cart Computer
 Test Item : Band Edge
 Test Site : No.3 OATS
 Test Mode : Mode 2: Transmit - 3Mbps (8DPSK) (2480MHz) (Hopping Bandedge) (22")

RF Radiated Measurement (VERTICAL):

Channel No.	Frequency (MHz)	Correct Factor (dB)	Reading Level (dBμV)	Emission Level (dBμV/m)	Peak Limit (dBμV/m)	Average Limit (dBμV/m)	Result
78 (Peak)	2472.775	-1.365	89.178	87.814	--	--	Pass
78 (Peak)	2483.500	-1.305	57.474	56.169	74.00	54.00	Pass
78 (Average)	2471.906	-1.369	85.866	84.497	--	--	Pass
78 (Average)	2483.500	-1.305	42.265	40.960	74.00	54.00	Pass

Figure Channel 78: VERTICAL (Peak)

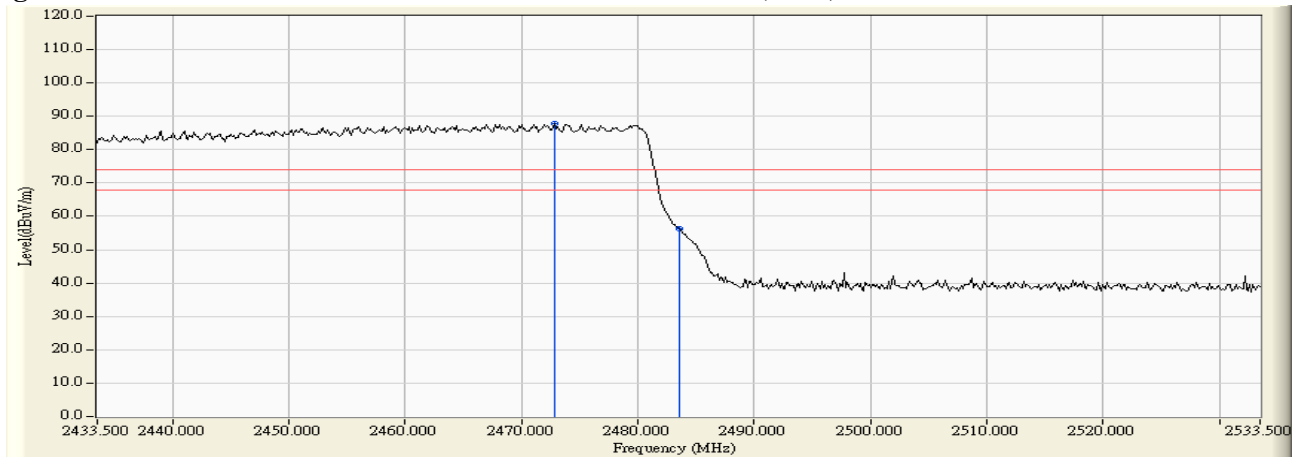
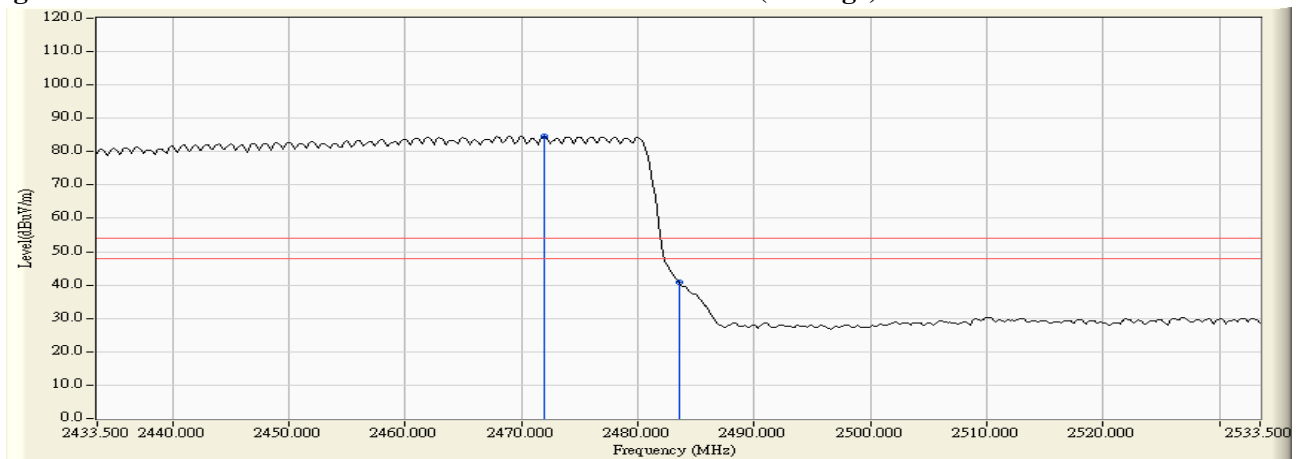

Figure Channel 78: VERTICAL (Average)



Note:

1. All readings above 1GHz are performed with peak and/or average measurements as necessary.
2. Peak measurements: RBW = 1MHz, VBW = 3 MHz, Sweep: Auto.
3. Average measurements: RBW = 1MHz, VBW = 10 Hz, Sweep: Auto.
4. “ * ”, means this data is the worst emission level.
5. Measurement Level = Reading Level + Correction Factor.
6. The average measurement was not performed when the peak measured data is under the limit of average detection.

7. Channel Number

7.1. Test Equipment

	Equipment	Manufacturer	Model No./Serial No.	Last Cal.
	Spectrum Analyzer	R&S	FSP40 / 100170	Jun., 2015
	Spectrum Analyzer	Agilent	E4407B / US39440758	Jun., 2015
X	Spectrum Analyzer	Agilent	N9010A / MY48030495	Apr., 2015

Note: 1. All equipments are calibrated every one year.
 2. The test instruments marked by “X” are used to measure the final test results.

7.2. Test Setup

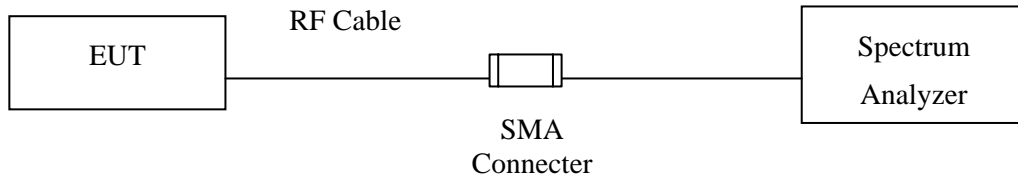

7.3. Limit

Frequency hopping systems operating in the 2400-2483.5 MHz bands shall use at least 75 hopping frequencies.

7.4. Test Procedure

The EUT was setup to ANSI C63.4, 2014; tested to FHSS test procedure of FCC Public Notice DA 00-705 for compliance to FCC 47CFR 15.247 requirements.

7.5. Uncertainty

N/A

7.6. Test Result of Channel Number

Product : Medical Cart Computer
 Test Item : Channel Number
 Test Site : No.3 OATS
 Test Mode : Mode 1: Transmit - 1Mbps (GFSK) (19''+22''+24'')

Frequency Range (MHz)	Measurement (Hopping Channel)	Required Limit (Hopping Channel)	Result
2402 ~ 2480	79	>75	Pass

2402-2421MHz

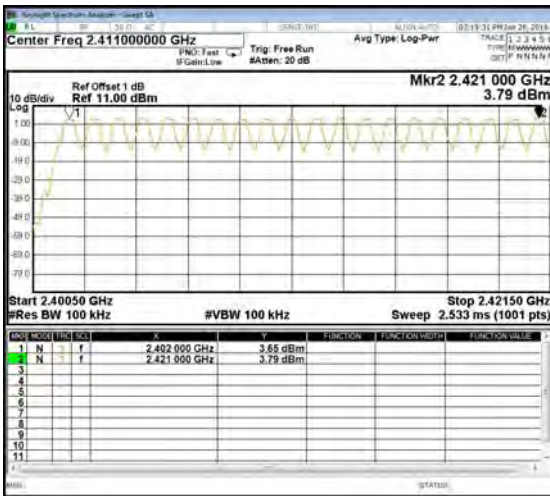

2422-2441MHz

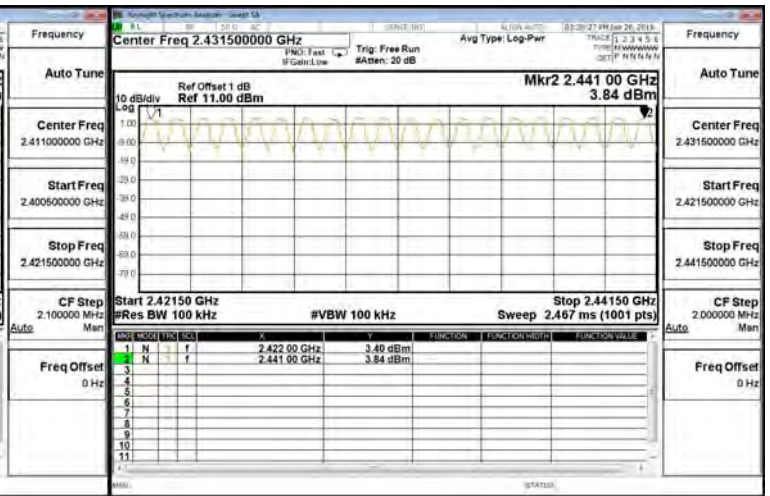

2442-2461MHz

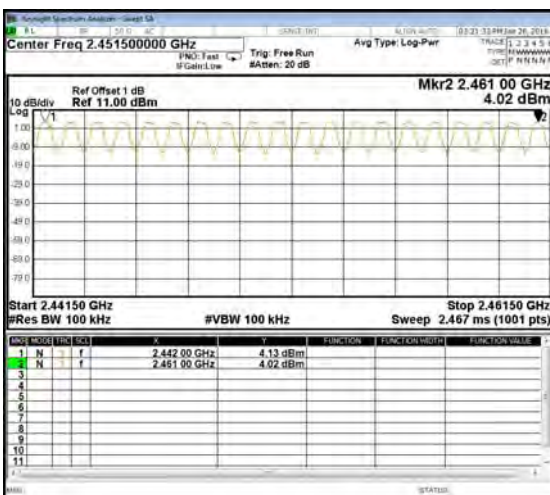

2462-2480MHz

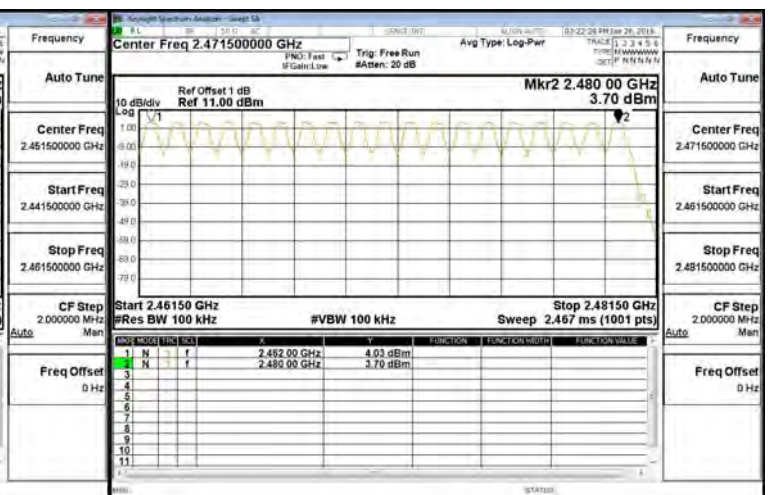

Product : Medical Cart Computer
 Test Item : Channel Number
 Test Site : No.3 OATS
 Test Mode : Mode 2: Transmit - 3Mbps (8DPSK) (19''+22''+24'')

Frequency Range (MHz)	Measurement (Hopping Channel)	Required Limit (Hopping Channel)	Result
2402 ~ 2480	79	>75	Pass

2402-2421MHz

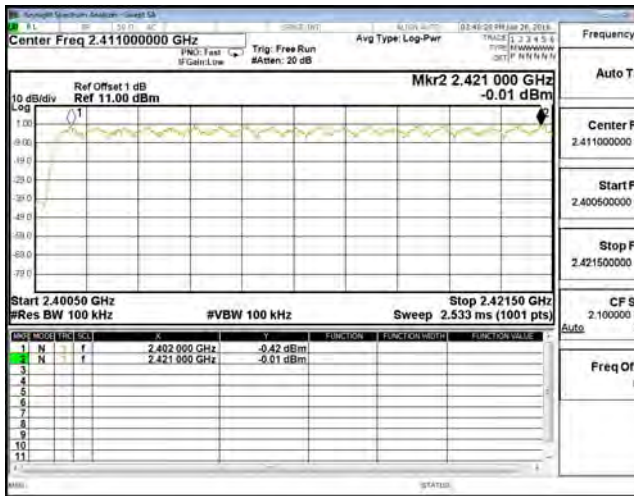

2422-2441MHz

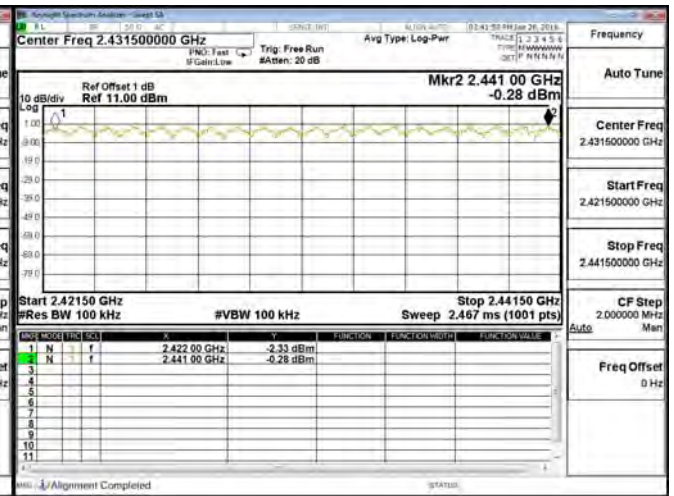

2442-2461MHz

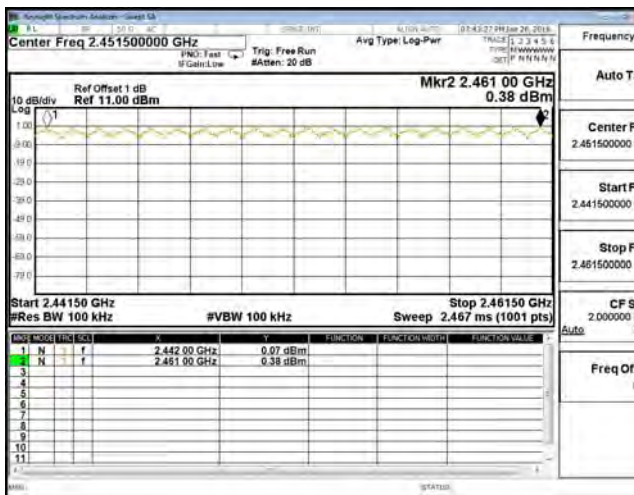

2462-2480MHz

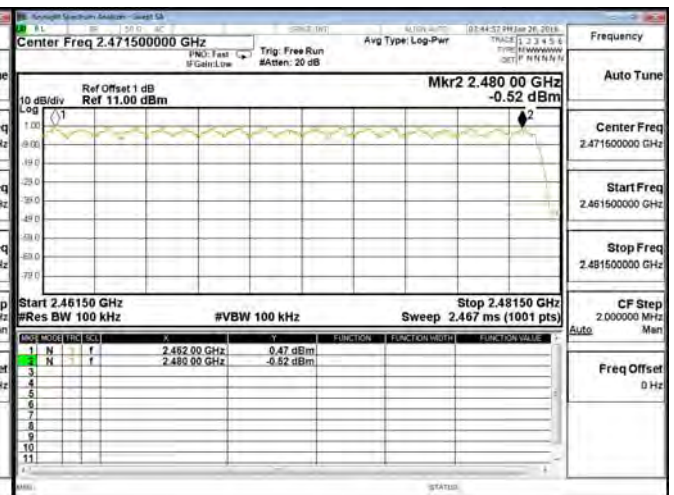

8. Channel Separation

8.1. Test Equipment

	Equipment	Manufacturer	Model No./Serial No.	Last Cal.
	Spectrum Analyzer	R&S	FSP40 / 100170	Jun., 2015
	Spectrum Analyzer	Agilent	E4407B / US39440758	Jun., 2015
X	Spectrum Analyzer	Agilent	N9010A / MY48030495	Apr., 2015

Note: 1. All equipments are calibrated every one year.
2. The test instruments mark by “X” are used to measure the final test results.

8.2. Test Setup

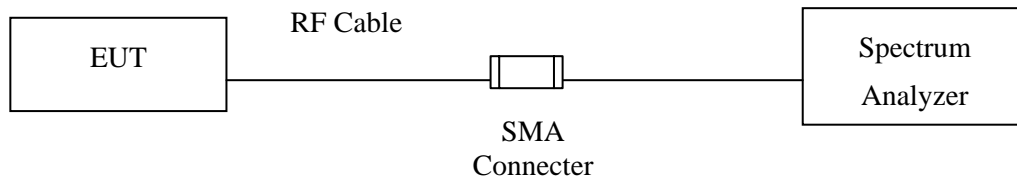

8.3. Limit

Frequency hopping systems shall have hopping channel carrier frequencies separated by a minimum of 25 kHz or the 20 dB bandwidth of the hopping channel, whichever is greater.

8.4. Test Procedure

The EUT was setup to ANSI C63.4, 2014; tested to FHSS test procedure of FCC Public Notice DA 00-705 for compliance to FCC 47CFR 15.247 requirements.

8.5. Uncertainty

± 150Hz

8.6. Test Result of Channel Separation

Product : Medical Cart Computer
 Test Item : Channel Separation
 Test Site : No.3 OATS
 Test Mode : Mode 1: Transmit - 1Mbps (GFSK) (19''+22''+24'')

Channel No.	Frequency (MHz)	Measurement Level (kHz)	Limit (kHz)	Limit of (2/3)*20dB Bandwidth (kHz)	Result
00	2402	1000	>25 kHz	753.3	Pass
39	2441	1000	>25 kHz	753.3	Pass
78	2480	1000	>25 kHz	760.0	Pass

NOTE: The 20dB Bandwidth is refer to section 10.

Channel 00 (2402MHz)

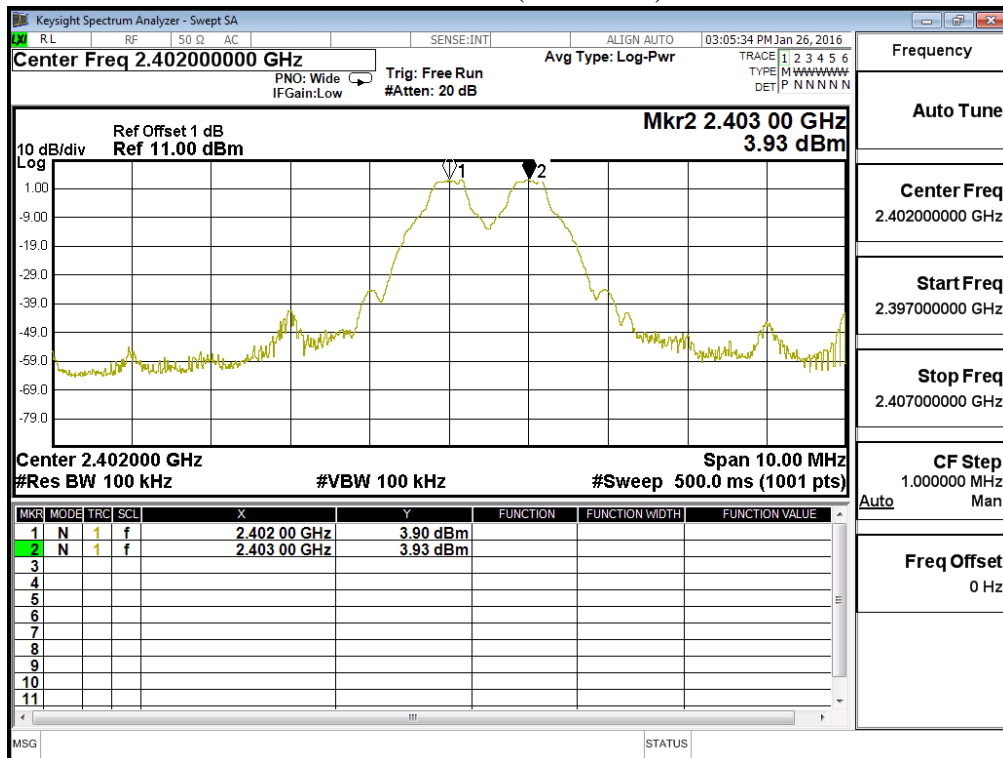

Channel 39 (2441MHz)

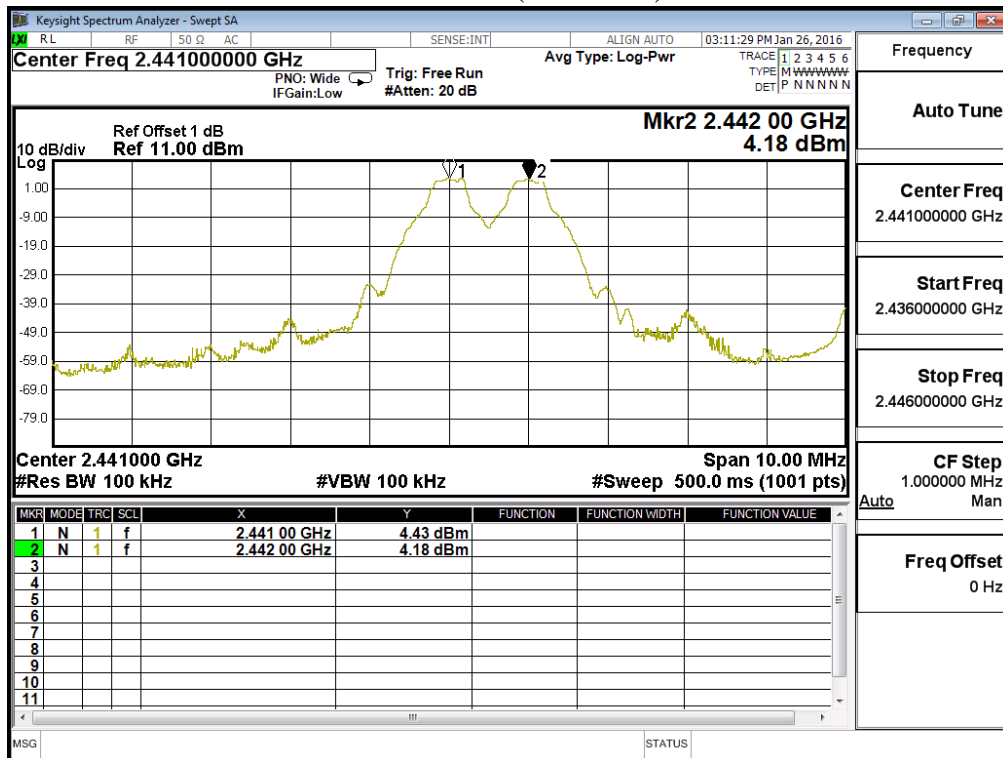

Channel 78 (2480MHz)

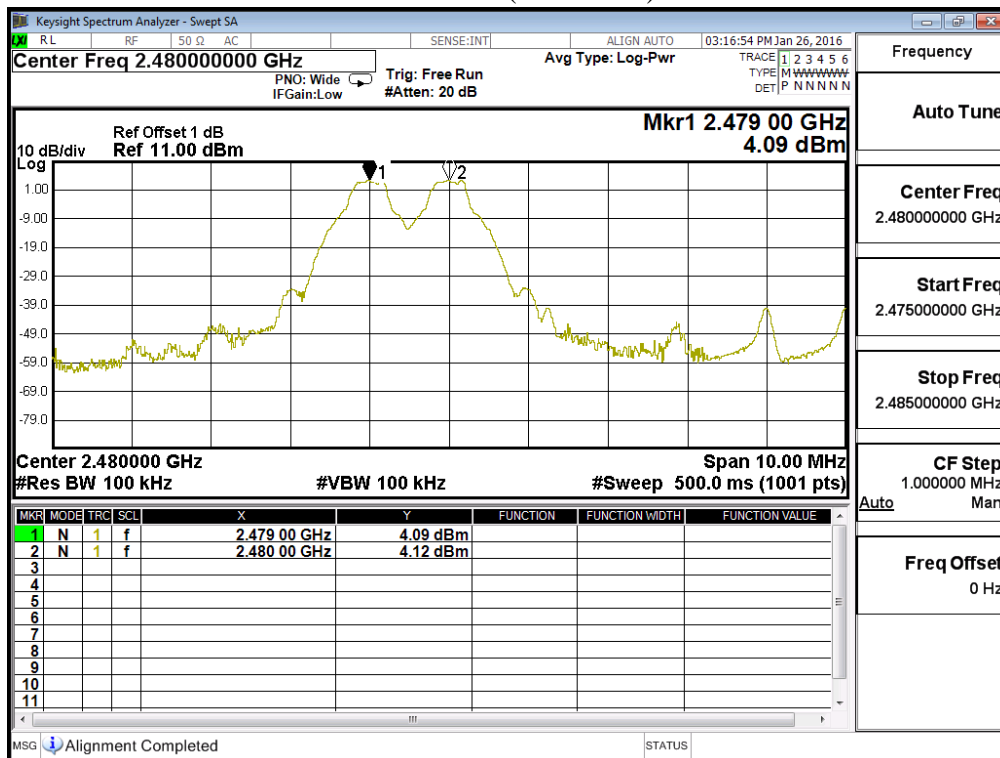

Product : Medical Cart Computer
 Test Item : Channel Separation
 Test Site : No.3 OATS
 Test Mode : Mode 2: Transmit - 3Mbps (8DPSK) (19''+22''+24'')

Channel No.	Frequency (MHz)	Measurement Level (kHz)	Limit (kHz)	Limit of (2/3)*20dB Bandwidth (kHz)	Result
00	2402	1000	>25 kHz	990.7	Pass
39	2441	1000	>25 kHz	990.0	Pass
78	2480	1000	>25 kHz	990.7	Pass

NOTE: The 20dB Bandwidth is refer to section 10.

Channel 00 (2402MHz)

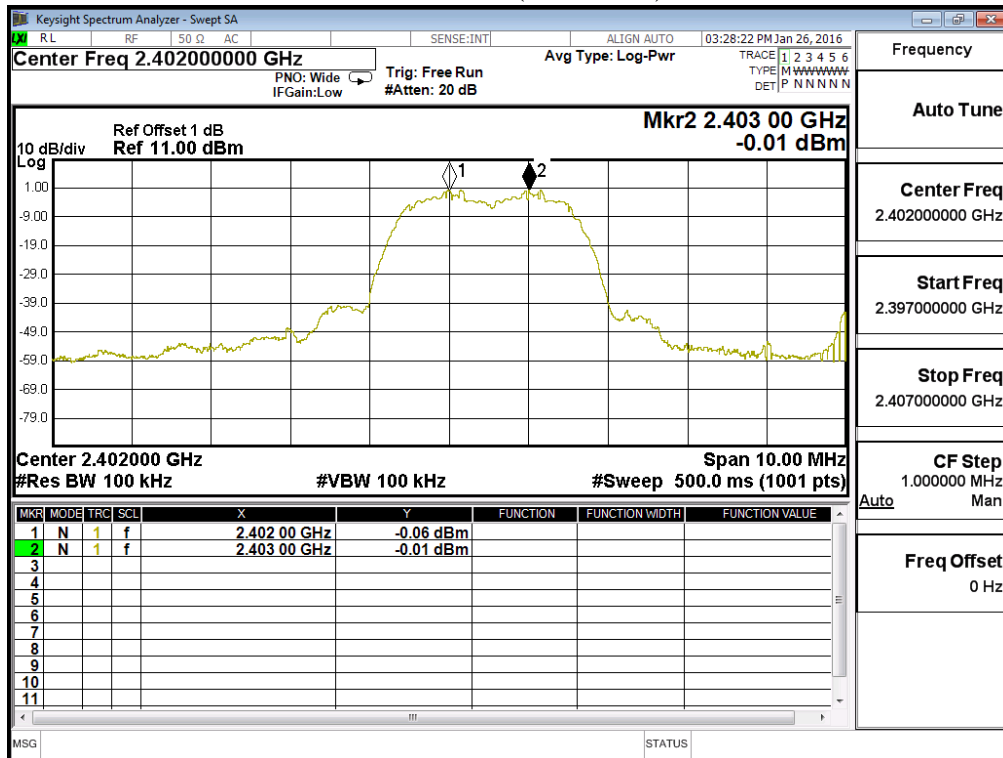

Channel 39 (2441MHz)

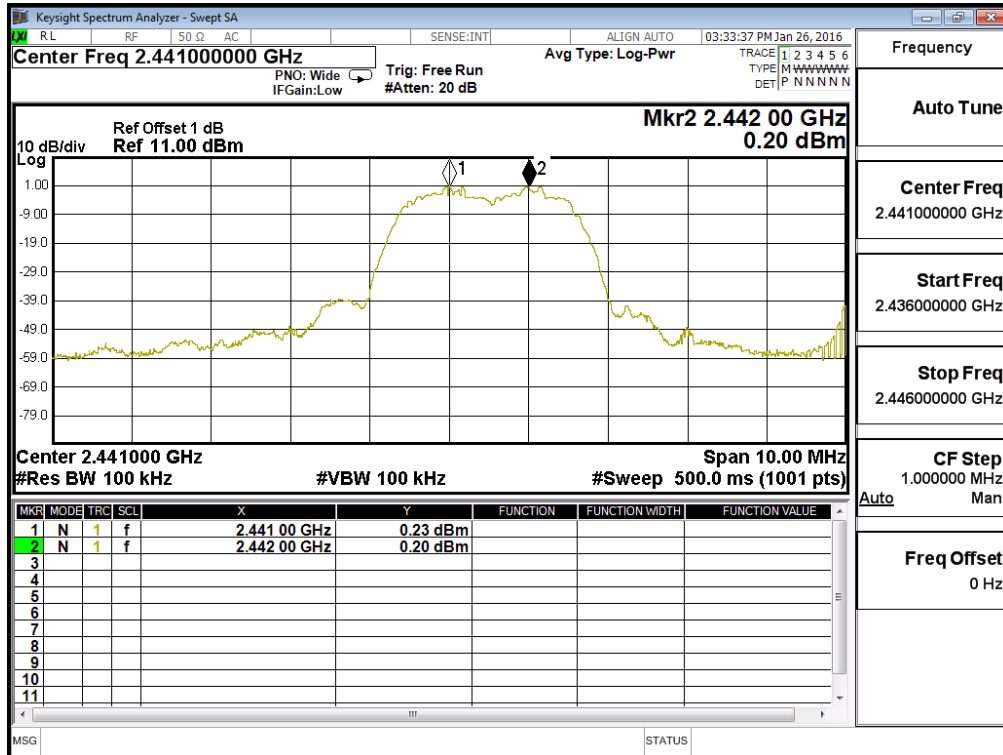

Channel 78 (2480MHz)

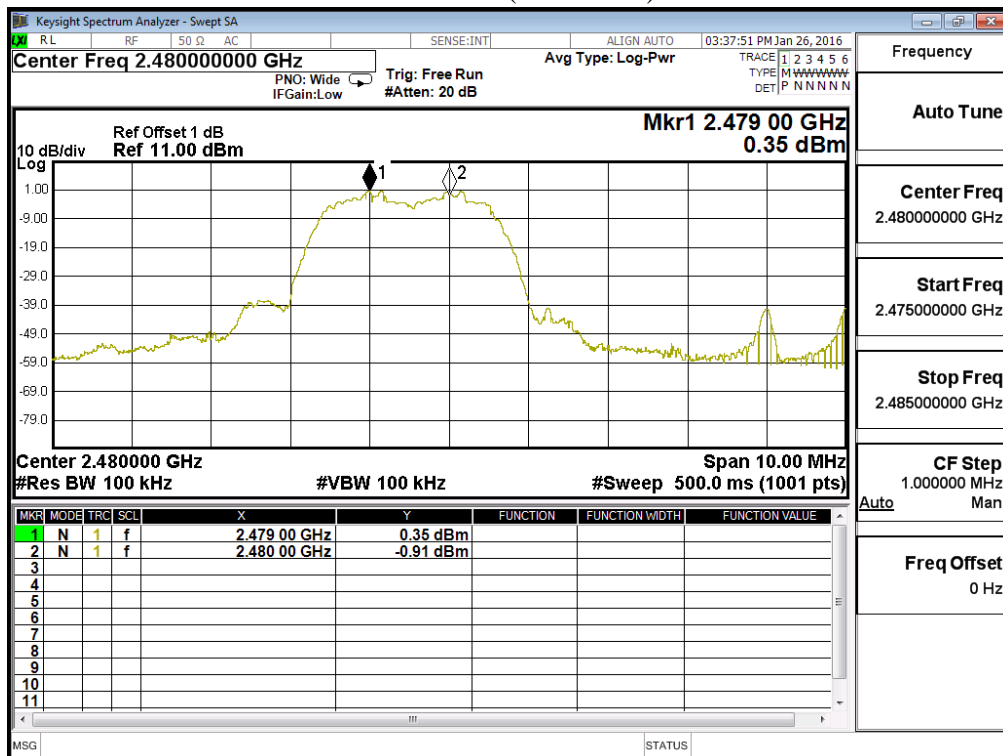

9. Dwell Time

9.1. Test Equipment

	Equipment	Manufacturer	Model No./Serial No.	Last Cal.
	Spectrum Analyzer	R&S	FSP40 / 100170	Jun., 2015
	Spectrum Analyzer	Agilent	E4407B / US39440758	Jun., 2015
X	Spectrum Analyzer	Agilent	N9010A / MY48030495	Apr., 2015

Note: 1. All equipments are calibrated every one year.
2. The test instruments marked by “X” are used to measure the final test results.

9.2. Test Setup

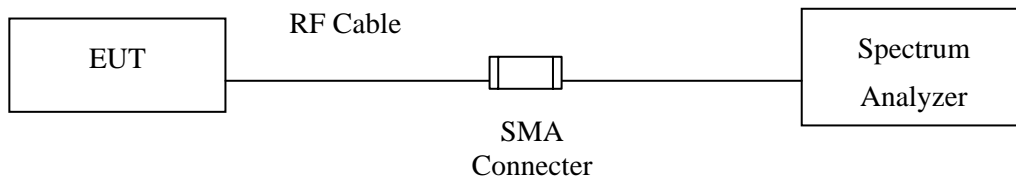

9.3. Limit

The dwell time shall be the average time of occupancy on any frequency shall not be greater than 0.4 seconds within a 30 second period.

9.4. Test Procedure

The EUT was setup to ANSI C63.4, 2014; tested to FHSS test procedure of FCC Public Notice DA 00-705 for compliance to FCC 47CFR 15.247 requirements.

9.5. Uncertainty

± 25msec

9.6. Test Result of Dwell Time

Product : Medical Cart Computer
 Test Item : Dwell Time
 Test Site : No.3 OATS
 Test Mode : Mode 1: Transmit - 1Mbps (GFSK) (Channel 00,39,78 –DH5) (19’’+22’’+24’’)

Frequency (MHz)	Time slot length (ms)	Hopping of Number	Sweep time (ms)	Duty cycle	Dwell Time (Sec)	Limit (Sec)	Result
2402	2.877	13	50	0.75	0.299	0.4	Pass
2441	2.877	13	50	0.75	0.299	0.4	Pass
2480	2.877	13	50	0.75	0.299	0.4	Pass

Duty cycle = ((Time slot length(ms)*Hopping of Number) / Sweep time (ms))

Dwell time = (Duty cycle /79) * (79*0.4)

CH 00 Time Interval between hops

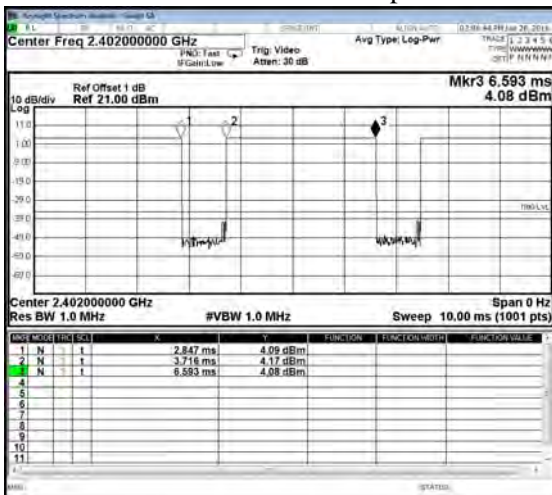

CH 00 Transmission Time

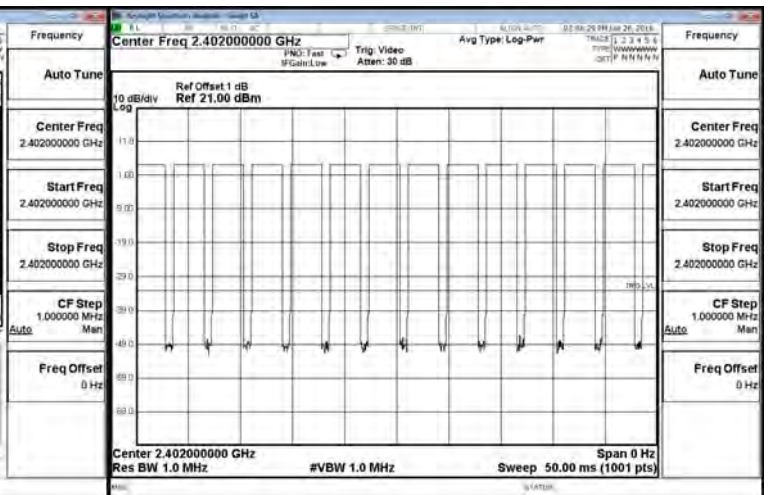

CH39 Time Interval between hops

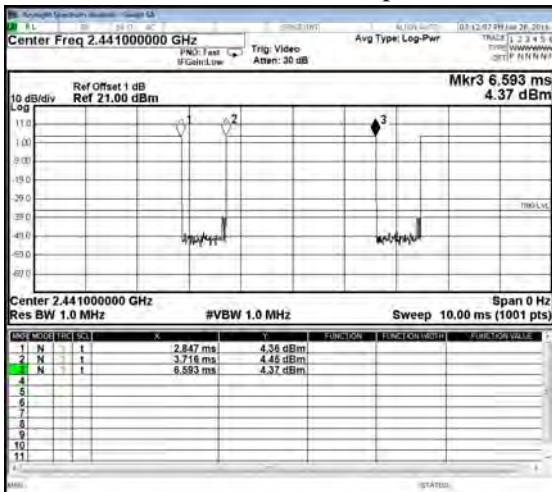

CH 39Transmission Time

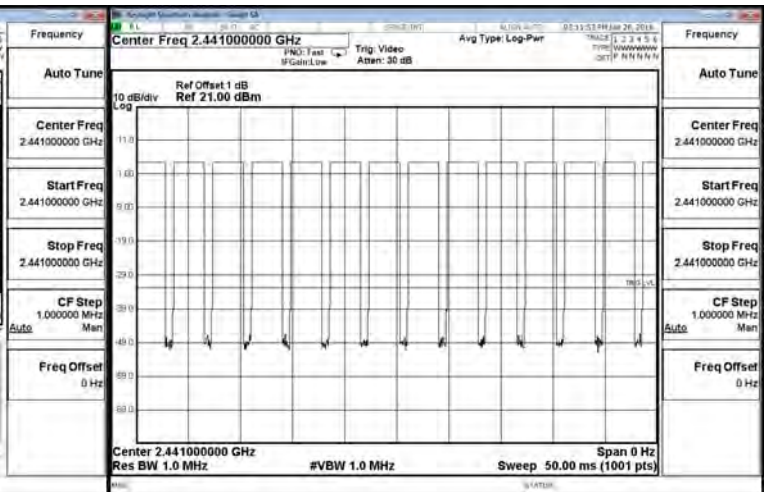

CH 78 Time Interval between hops

CH 78 Transmission Time

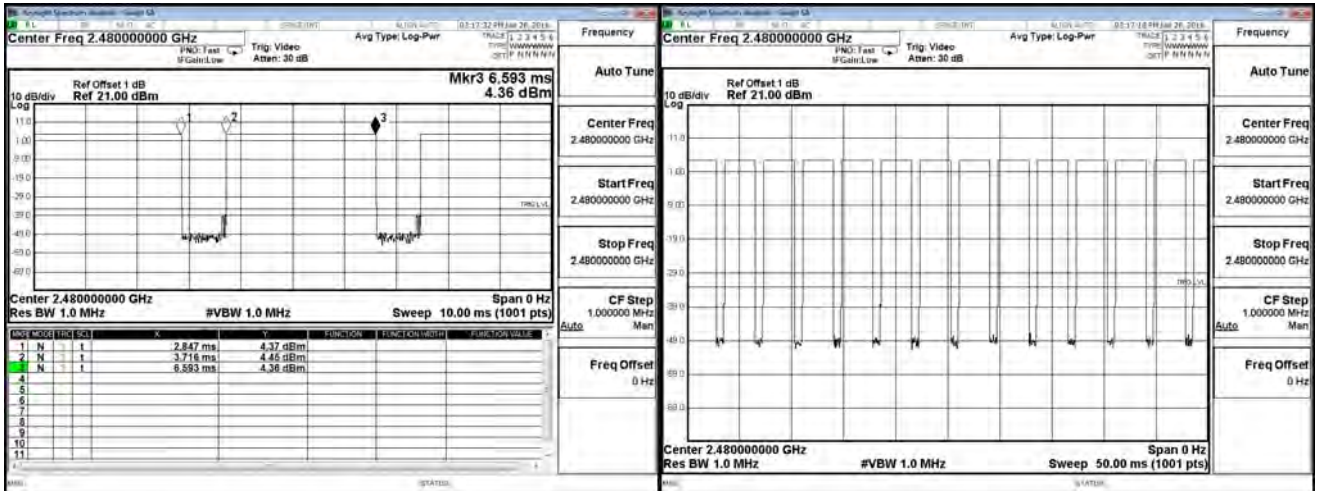

Note:

The dwell times of the packet type of DH1, DH3, and DH5 are tested. Only the worst case is shown on the report.

Product : Medical Cart Computer
 Test Item : Dwell Time
 Test Site : No.3 OATS
 Test Mode : Mode 2: Transmit - 3Mbps (8DPSK) (Channel 00,39,78 –DH5) (19’’+22’’+24’’)

Frequency (MHz)	Time slot length (ms)	Hopping of Number	Sweep time (ms)	Duty cycle	Dwell Time (Sec)	Limit (Sec)	Result
2402	2.887	13	50	0.75	0.300	0.4	Pass
2441	2.887	13	50	0.75	0.300	0.4	Pass
2480	2.887	13	50	0.75	0.300	0.4	Pass

Duty cycle = ((Time slot length(ms)*Hopping of Number) / Sweep time (ms))

Dwell time = (Duty cycle /79) * (79*0.4)

CH 00 Time Interval between hops

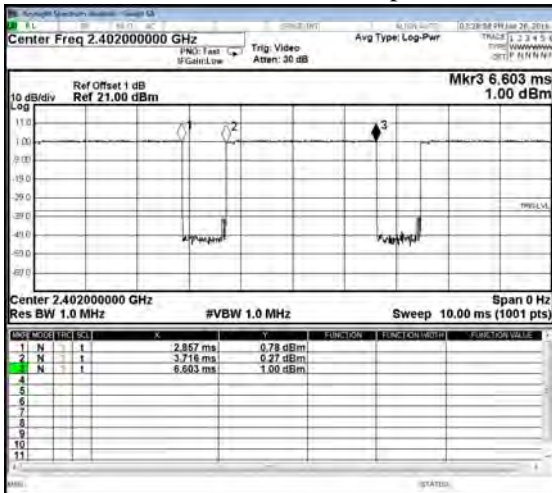

CH 00 Transmission Time

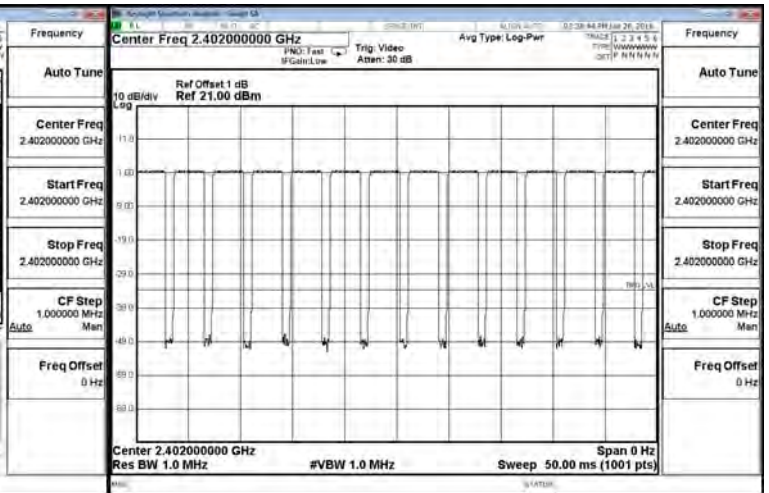

CH39 Time Interval between hops

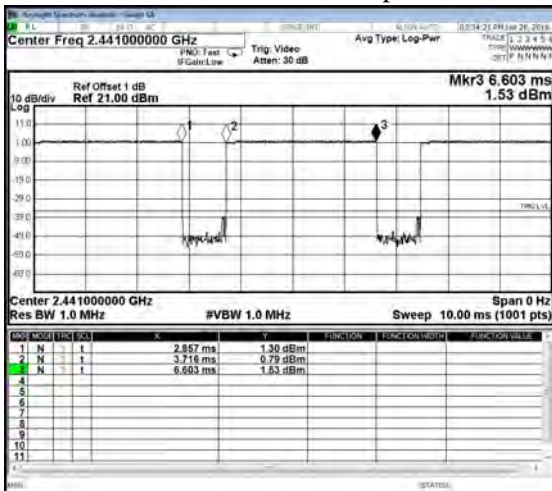

CH 39 Transmission Time

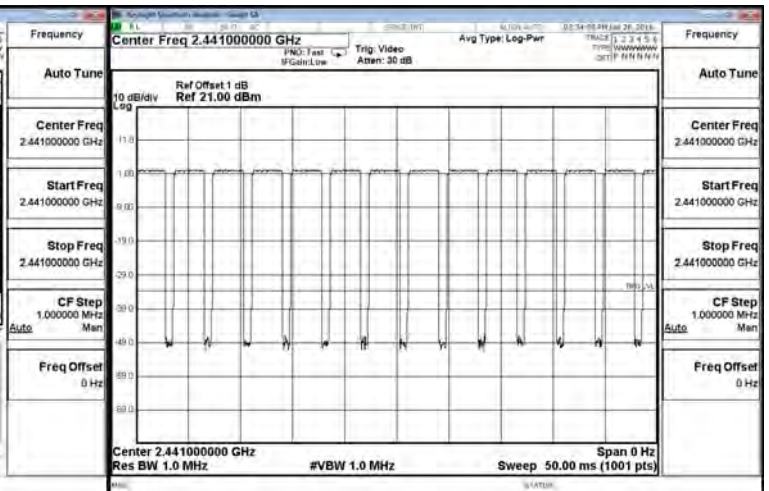

CH 78 Time Interval between hops

CH 78 Transmission Time



Note:

The dwell times of the packet type of DH1, DH3, and DH5 are tested. Only the worst case is shown on the report.

10. Occupied Bandwidth

10.1. Test Equipment

	Equipment	Manufacturer	Model No./Serial No.	Last Cal.
	Spectrum Analyzer	R&S	FSP40 / 100170	Jun., 2015
	Spectrum Analyzer	Agilent	E4407B / US39440758	Jun., 2015
X	Spectrum Analyzer	Agilent	N9010A / MY48030495	Apr., 2015

Note: 1. All equipments are calibrated every one year.
2. The test instruments marked by “X” are used to measure the final test results.

10.2. Test Setup

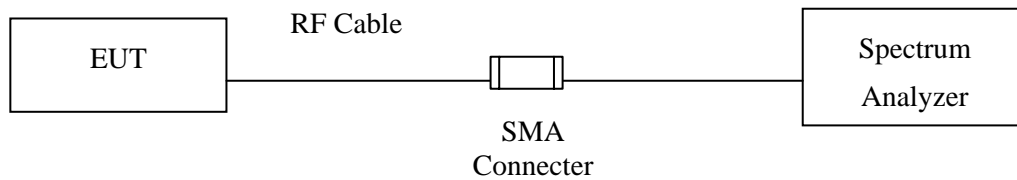

10.3. Limits

N/A

10.4. Test Procedure

The EUT was setup to ANSI C63.4, 2014; tested to FHSS test procedure of FCC Public Notice DA 00-705 for compliance to FCC 47CFR 15.247 requirements.

10.5. Uncertainty

$\pm 150\text{Hz}$

10.6. Test Result of Occupied Bandwidth

Product : Medical Cart Computer
 Test Item : Occupied Bandwidth Data
 Test Site : No.3 OATS
 Test Mode : Mode 1: Transmit - 1Mbps (GFSK) (19''+22''+24'')

Channel No.	Frequency (MHz)	Measurement Level (kHz)	Required Limit (kHz)	Result
00	2402	1130	--	NA
39	2441	1130	--	NA
78	2480	1140	--	NA

Figure Channel 00:

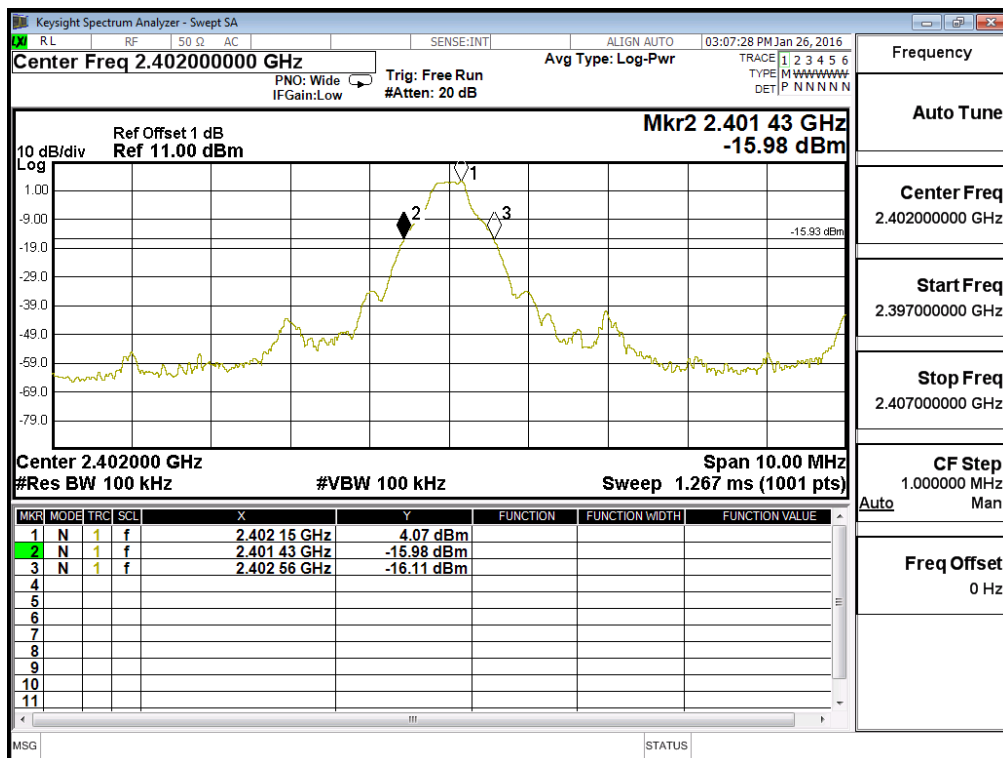

Figure Channel 39:

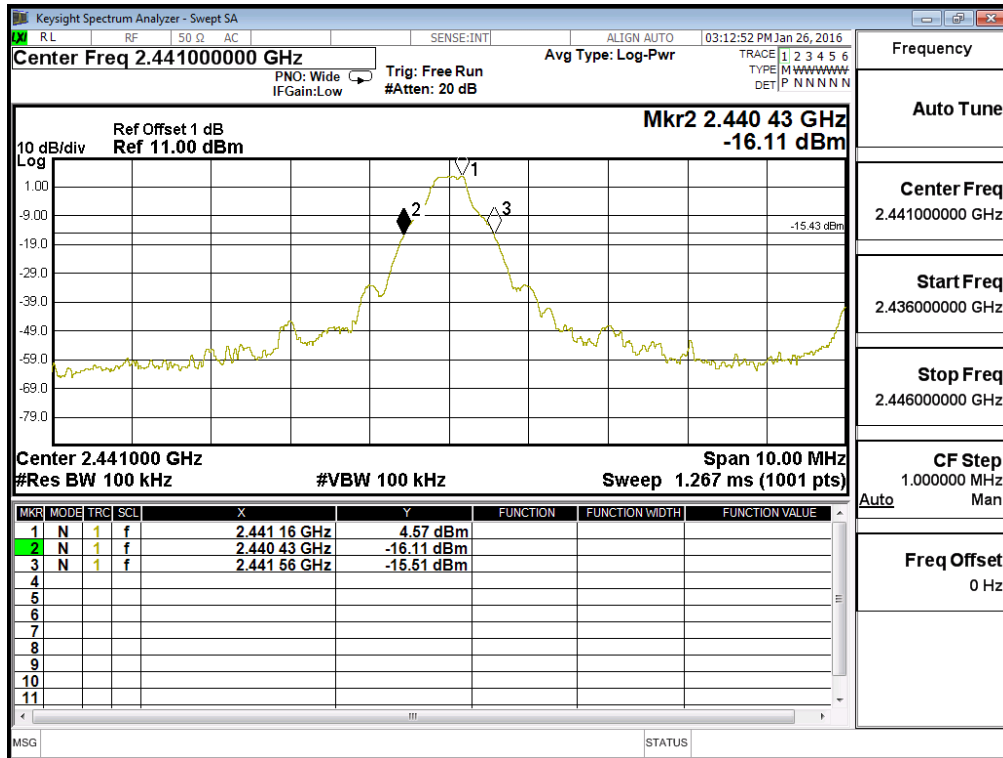
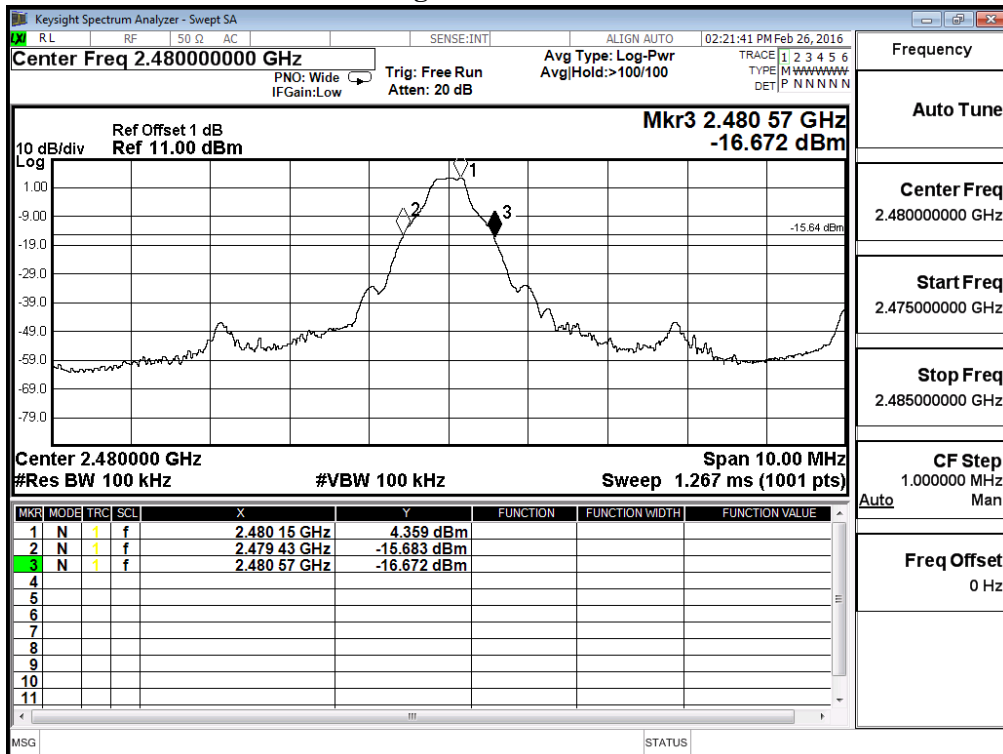

Figure Channel 78:



Product : Medical Cart Computer
 Test Item : Occupied Bandwidth Data
 Test Site : No.3 OATS
 Test Mode : Mode 2: Transmit - 3Mbps (8DPSK) (2402MHz) (19''+22''+24'')

Channel No.	Frequency (MHz)	Measurement Level (kHz)	Required Limit (kHz)	Result
00	2402	1486	--	NA
39	2441	1485	--	NA
78	2480	1486	--	NA

Figure Channel 00:

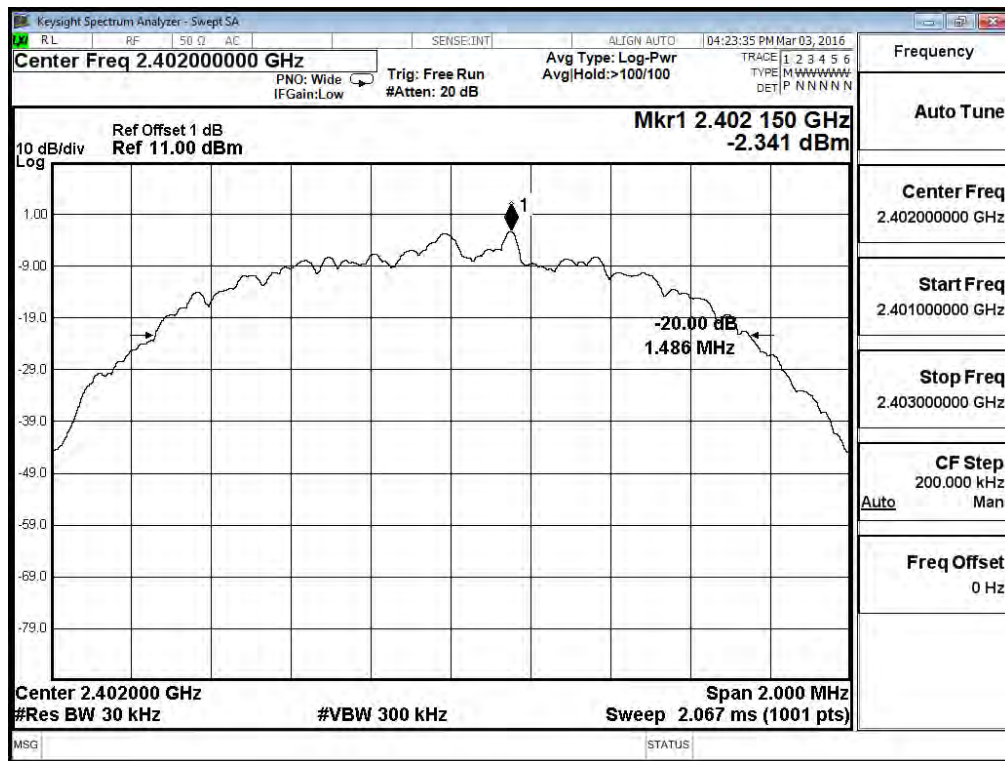

Figure Channel 39:

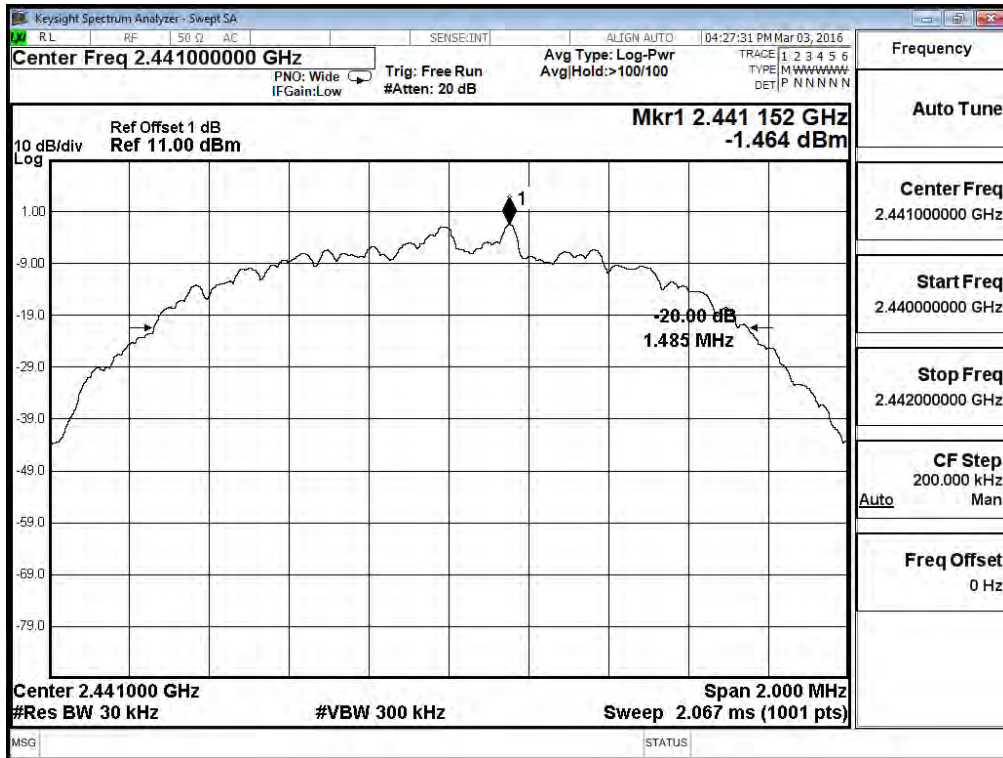
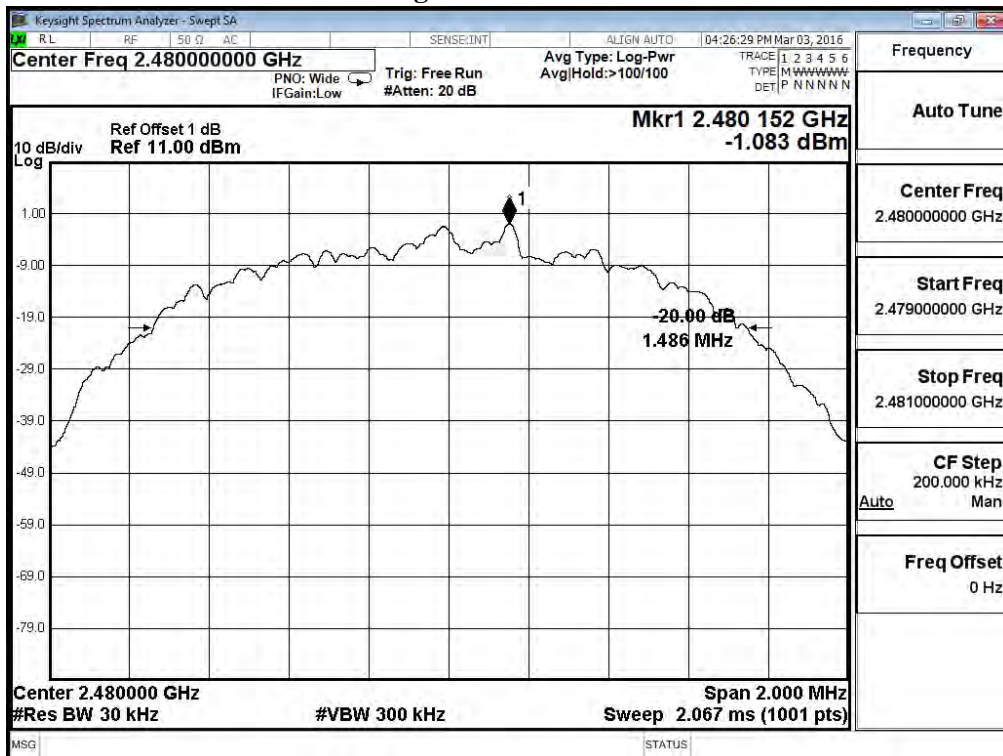

Figure Channel 78:



11. EMI Reduction Method During Compliance Testing

No modification was made during testing.