



FCC RF Test Report

APPLICANT : DT Research Inc.
EQUIPMENT : Mobile Tablet
BRAND NAME : DT Research Inc.
MODEL NAME : DT398H
FCC ID : YE3800C
STANDARD : FCC 47 CFR Part 2, 22(H), 24(E)
CLASSIFICATION : PCS Licensed Transmitter (PCB)

The product was received on Sep. 16, 2014 and testing was completed on Dec. 18, 2014. We, SPORTON INTERNATIONAL INC., would like to declare that the tested sample has been evaluated in accordance with the test procedures given in ANSI / TIA / EIA-603-C-2004 and has been in compliance with the applicable technical standards.

The test results in this report apply exclusively to the tested model / sample. Without written approval of SPORTON INTERNATIONAL INC., the test report shall not be reproduced except in full.

Reviewed by: Joseph Lin / Supervisor

Approved by: Jones Tsai / Manager



SPORTON INTERNATIONAL INC.

No. 52, Hwa Ya 1st Rd., Hwa Ya Technology Park, Kwei-Shan Hsiang, Tao Yuan Hsien, Taiwan, R.O.C.



TABLE OF CONTENTS

REVISION HISTORY.....3

SUMMARY OF TEST RESULT4

1 GENERAL DESCRIPTION5

 1.1 Applicant.....5

 1.2 Manufacturer5

 1.3 Product Feature of Equipment Under Test5

 1.4 Product Specification subjective to this standard.....6

 1.5 Modification of EUT6

 1.6 Maximum ERP/EIRP Power, Frequency Tolerance, and Emission Designator6

 1.7 Testing Location7

 1.8 Applicable Standards7

2 TEST CONFIGURATION OF EQUIPMENT UNDER TEST.....8

 2.1 Test Mode.....8

 2.2 Connection Diagram of Test System9

 2.3 Support Unit used in test configuration9

 2.4 Measurement Results Explanation Example9

3 TEST RESULT.....10

 3.1 Conducted Output Power and ERP/EIRP Measurement.....10

 3.2 Peak-to-Average Ratio12

 3.3 99% Occupied Bandwidth and 26dB Bandwidth Measurement.....18

 3.4 Band Edge Measurement.....26

 3.5 Conducted Spurious Emission Measurement.....32

 3.6 Field Strength of Spurious Radiation Measurement48

 3.7 Frequency Stability Measurement.....56

4 LIST OF MEASURING EQUIPMENT60

5 UNCERTAINTY OF EVALUATION.....62

APPENDIX A. SETUP PHOTOGRAPHS



SUMMARY OF TEST RESULT

Report Section	FCC Rule	IC Rule	Description	Limit	Result	Remark
3.1	§2.1046	RSS-132 (5.4) RSS-133 (6.4)	Conducted Output Power	N/A	PASS	-
	§22.913(a)(2)	RSS-132(5.4) SRSP-503(5.1.3)	Effective Radiated Power	< 7 Watts	PASS	-
	§24.232(c)	RSS-133 (6.4) SRSP-510(5.1.2)	Equivalent Isotropic Radiated Power	< 2 Watts	PASS	-
3.2	§24.232(d)	RSS-132 (5.4) RSS-133(6.4)	Peak-to-Average Ratio	<13 dB	PASS	-
3.3	§2.1049 §22.917(b) §24.238(b)	RSS-GEN(4.6.1) RSS-133(2.3)	Occupied Bandwidth	N/A	PASS	-
3.4	§2.1051 §22.917(a) §24.238(a)	RSS-132 (5.5) RSS-133 (6.5)	Band Edge Measurement	< 43+10log ₁₀ (P[Watts])	PASS	-
3.5	§2.1051 §22.917(a) §24.238(a)	RSS-132 (5.5) RSS-133 (6.5)	Conducted Spurious Emission	< 43+10log ₁₀ (P[Watts])	PASS	-
3.6	§2.1053 §22.917(a) §24.238(a)	RSS-132 (5.5) RSS-133 (6.5)	Field Strength of Spurious Radiation	< 43+10log ₁₀ (P[Watts])	PASS	Under limit 14.11 dB at 5730.000 MHz
3.7	§2.1055 §22.355	RSS-132(5.3)	Frequency Stability for Temperature & Voltage	< 2.5 ppm for Part 22 Within Authorized Band	PASS	-
	§2.1055 §24.235	RSS-133(6.3)				



1 General Description

1.1 Applicant

DT Research Inc.
6F, NO. 1, NingPo E. St., Taipei, 100 Taiwan, R.O.C.

1.2 Manufacturer

DT Research Inc.
6F, NO. 1, NingPo E. St., Taipei, 100 Taiwan, R.O.C.

1.3 Product Feature of Equipment Under Test

Product Feature	
Equipment	Mobile Tablet
Brand Name	DT Research Inc.
Model Name	DT398H
FCC ID	YE3800C
EUT supports Radios application	CDMA/EV-DO/LTE WLAN 11a/b/g/n (HT20/HT40) WLAN 11ac (VHT20/VHT40/VHT80) Bluetooth v4.0 EDR/LE
EUT Stage	Production Unit

Remark: The above EUT's information was declared by manufacturer. Please refer to the specifications or user's manual for more detailed description.



1.4 Product Specification subjective to this standard

Product Specification subjective to this standard	
Tx Frequency	CDMA2000 BC0: 824.70 MHz ~ 848.31 MHz CDMA2000 BC1: 1851.25 MHz ~ 1908.75 MHz
Rx Frequency	CDMA2000 BC0: 869.70 MHz ~ 893.31 MHz CDMA2000 BC1: 1931.25 MHz ~ 1988.75 MHz
Maximum Output Power to Antenna	CDMA2000 BC0 : 23.93 dBm CDMA2000 BC1 : 23.91 dBm
99% Occupied Bandwidth	CDMA2000 BC0: 1.28MHz CDMA2000 BC1: 1.28MHz
Antenna Type	PIFA Antenna
Antenna Gain	CDMA2000 BC0 : 0.54 dBi CDMA2000 BC1 : 1.18 dBi
Type of Modulation	CDMA2000 : QPSK CDMA2000 1xEV-DO : QPSK/8PSK

1.5 Modification of EUT

No modifications are made to the EUT during all test items.

1.6 Maximum ERP/EIRP Power, Frequency Tolerance, and Emission Designator

FCC Rule	System	Type of Modulation	Maximum ERP/EIRP (W)	Frequency Tolerance (ppm)	Emission Designator
Part 22	CDMA2000 BC0 1xRTT	QPSK	0.171	0.0167 ppm	1M28F9W
Part 24	CDMA2000 BC1 1xEV-DO Rev. 0	QPSK	0.323	0.0021 ppm	1M28F9W



1.7 Testing Location

Sporton Lab is accredited to ISO 17025 by Taiwan Accreditation Foundation (TAF code : 1190) and the FCC designation No. TW1022 under the FCC 2.948(e) by Mutual Recognition Agreement (MRA) in FCC Test.

Test Site	SPORTON INTERNATIONAL INC.	
Test Site Location	No. 52, Hwa Ya 1 st Rd., Hwa Ya Technology Park, Kwei-Shan Hsiang, Tao Yuan Hsien, Taiwan, R.O.C. TEL: +886-3-327-3456 FAX: +886-3-328-4978	
Test Site No.	Sporton Site No.	
	TH02-HY	03CH10-HY

1.8 Applicable Standards

According to the specifications of the manufacturer, the EUT must comply with the requirements of the following standards:

- ♦ FCC 47 CFR Part 2, 22(H), 24(E)
- ♦ ANSI / TIA / EIA-603-C-2004
- ♦ FCC KDB 971168 D01 Power Meas. License Digital Systems v02r02
- ♦ FCC KDB 412172 D01 Determining ERP and ERIP v01

Remark:

1. All test items were verified and recorded according to the standards and without any deviation during the test.
2. This EUT has also been tested and complied with the requirements of FCC Part 15, Subpart B, recorded in a separate test report.



2 Test Configuration of Equipment Under Test

2.1 Test Mode

Antenna port conducted and radiated test items were performed according to KDB 971168 D01 Power Meas. License Digital Systems v02r02 with maximum output power.

Radiated measurements were performed with rotating EUT in different three orthogonal test planes to find the maximum emission.

Radiated emissions were investigated as following frequency range:

1. 30 MHz to 9000 MHz for CDMA2000 BC0.
2. 30 MHz to 19000 MHz for CDMA2000 BC1.

All modes and data rates and positions were investigated.

Test modes are chosen to be reported as the worst case configuration below:

Test Modes		
Band	Radiated TCs	Conducted TCs
CDMA2000 BC0	■ 1xRTT Link Mode	■ 1xRTT Link Mode
CDMA2000 BC1	■ 1xEV-DO Rev. 0 Link Mode	■ 1xEV-DO Rev. 0 Link Mode

Conducted Power Measurement Results:

Conducted Power (*Unit: dBm)						
Band	CDMA2000 BC0			CDMA2000 BC1		
Channel	1013	384	777	25	600	1175
Frequency	824.7	836.52	848.31	1851.25	1880	1908.75
1xRTT RC1 SO55	23.73	23.93	23.71	23.84	23.79	23.74
1xRTT RC3 SO55	23.61	23.85	23.61	23.87	23.80	23.78
1xRTT RC3 SO32(+ F-SCH)	23.65	23.89	23.65	23.85	23.81	23.76
1xRTT RC3 SO32(+SCH)	23.59	23.85	23.58	23.87	23.82	23.79
1xEV-DO RTAP 153.6kbps	23.59	23.85	23.60	23.91	23.79	23.79
1xEV-DO RETAP 4096Bits	23.58	23.83	23.57	23.85	23.82	23.77

2.2 Connection Diagram of Test System

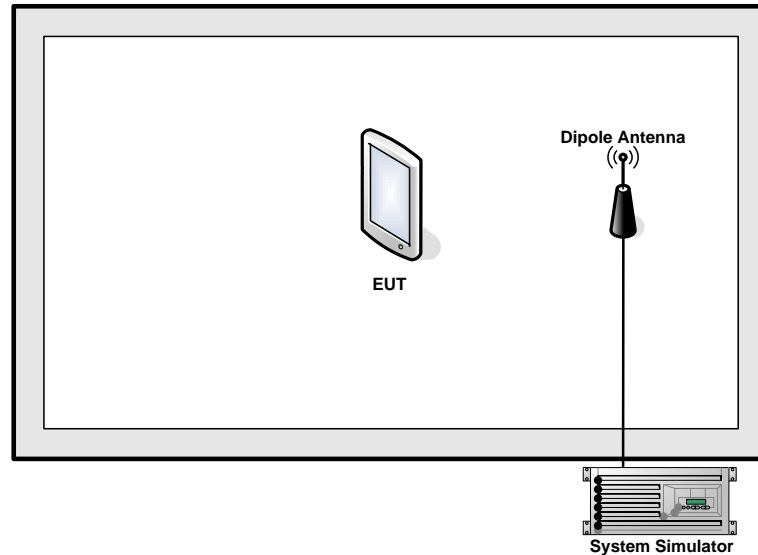

2.3 Support Unit used in test configuration

Item	Equipment	Trade Name	Model No.	FCC ID	Data Cable	Power Cord
1.	System Simulator	R&S	CMU 200	N/A	N/A	Unshielded, 1.8 m

2.4 Measurement Results Explanation Example

For all conducted test items:

The offset level is set in the spectrum analyzer to compensate the RF cable loss and attenuator factor between RF conducted output port and spectrum analyzer. With the offset compensation, the spectrum analyzer reading level will be exactly the RF output level.

The spectrum analyzer offset is derived from RF cable loss and attenuator factor.

Offset = RF cable loss + attenuator factor.

The following shows an offset computation example with RF cable loss 4.2 dB and a 10dB attenuator.

Example :

$$\begin{aligned} \text{Offset(dB)} &= \text{RF cable loss(dB)} + \text{attenuator factor(dB)}. \\ &= 4.2 + 10 = 14.2 \text{ (dB)} \end{aligned}$$

3 Test Result

3.1 Conducted Output Power and ERP/EIRP Measurement

3.1.1 Description of the Conducted Output Power and ERP/EIRP Measurement

A system simulator was used to establish communication with the EUT. Its parameters were set to enforce EUT transmitting at the maximum power. The measured power in the radio frequency on the transmitter output terminals shall be reported.

The ERP of mobile transmitters must not exceed 7 Watts for Band 850.

The EIRP of mobile transmitters must not exceed 2 Watts for Band 1900.

According to KDB 412172 D01 Power Approach,

$EIRP = P_T + G_T - L_C$, $ERP = EIRP - 2.15$, where

P_T = transmitter output power in dBm

G_T = gain of the transmitting antenna in dBi

L_C = signal attenuation in the connecting cable between the transmitter and antenna in dB

3.1.2 Measuring Instruments

The measuring equipment is listed in the section 4 of this test report.

3.1.3 Test Procedures

1. The transmitter output port was connected to the system simulator.
2. Set EUT at maximum power through system simulator.
3. Select lowest, middle, and highest channels for each band and different modulation.
4. Measure the maximum average power for CDMA

3.1.4 Test Setup

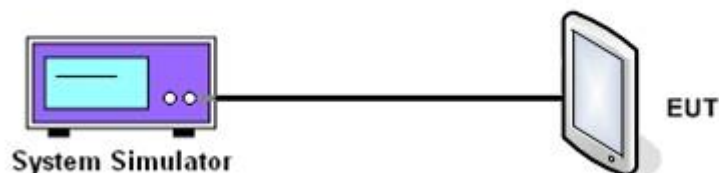



3.1.5 Test Result of Conducted Output Power

Cellular Band ($G_T - L_C = 0.54\text{dB}$)			
Modes	CDMA 2000 1xRTT		
Test Status	RC1+SO55		
Channel	1013 (Low)	384 (Mid)	777 (High)
Frequency (MHz)	824.70	836.52	848.31
Conducted Power P_T (dBm)	23.73	23.93	23.71
Conducted Power P_T (Watts)	0.24	0.25	0.23
ERP(dBm)	22.12	22.32	22.10
ERP(Watts)	0.163	0.171	0.162

PCS Band ($G_T - L_C = 1.18\text{dB}$)			
Modes	CDMA 2000 1xEV-DO Rev. 0		
Test Status	RTAP 153.6K		
Channel	25 (Low)	600 (Mid)	1175 (High)
Frequency (MHz)	1851.25	1880.00	1908.75
Conducted Power P_T (dBm)	23.91	23.82	23.79
Conducted Power P_T (Watts)	0.25	0.24	0.24
EIRP(dBm)	25.09	25	24.97
EIRP(Watts)	0.323	0.316	0.314

Note:

$EIRP = P_T + G_T - L_C$, $ERP = EIRP - 2.15$, where

P_T = transmitter output power in dBm

G_T = gain of the transmitting antenna in dBi

L_C = signal attenuation in the connecting cable between the transmitter and antenna in dB

3.2 Peak-to-Average Ratio

3.2.1 Description of the PAR Measurement

The peak-to-average ratio (PAR) of the transmission may not exceed 13 dB.

3.2.2 Measuring Instruments

The measuring equipment is listed in the section 4 of this test report.

3.2.3 Test Procedures

1. The testing follows FCC KDB 971168 v02r02 Section 5.7.1.
2. The EUT was connected to the spectrum analyzer and system simulator via a power divider.
3. Set the CCDF (Complementary Cumulative Distribution Function) option on the spectrum analyzer.
4. The highest RF powers were measured and recorded the maximum PAPR level associated with a probability of 0.1 %.
5. Record the deviation as Peak to Average Ratio.

3.2.4 Test Setup

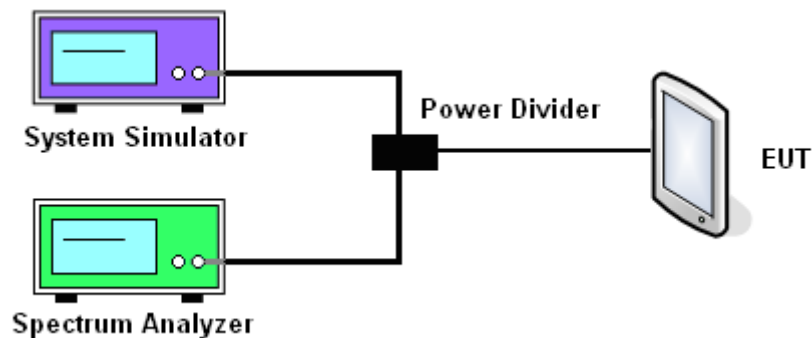



3.2.5 Test Result of Peak-to-Average Ratio

CDMA2000 BC0			
Modes	CDMA 2000 1xRTT		
Channel	1013 (Low)	384 (Mid)	777 (High)
Frequency (MHz)	824.70	836.52	848.31
Peak-to-Average Ratio (dB)	4.36	4.24	3.76

CDMA2000 BC1			
Modes	CDMA 2000 1xEV-DO Rev. 0		
Test Status	RTAP 153.6K		
Channel	25 (Low)	600 (Mid)	1175 (High)
Frequency (MHz)	1851.25	1880.00	1908.75
Peak-to-Average Ratio (dB)	3.76	4.12	3.08



3.2.6 Test Result (Plots) of Peak-to-Average Ratio

Band :	CDMA2000 BC0	Test Mode :	1xRTT Link (QPSK)
--------	--------------	-------------	-------------------

Peak-to-Average Ratio on Channel 1013 (824.70 MHz)

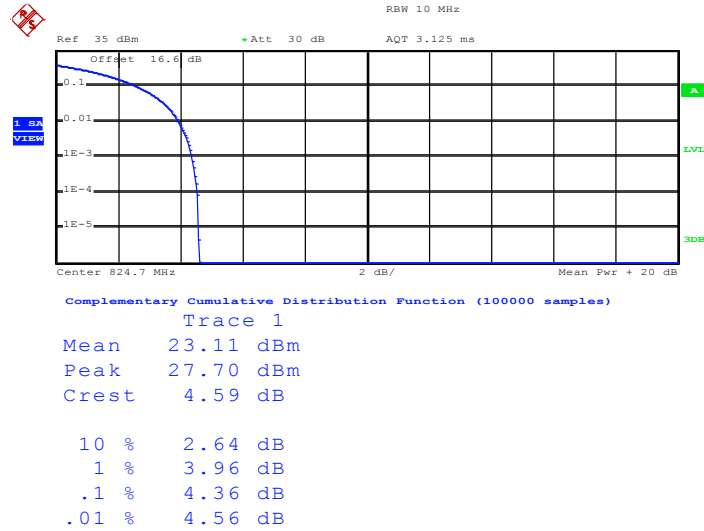

Date: 6.OCT.2014 15:52:59

Peak-to-Average Ratio on Channel 384 (836.52 MHz)

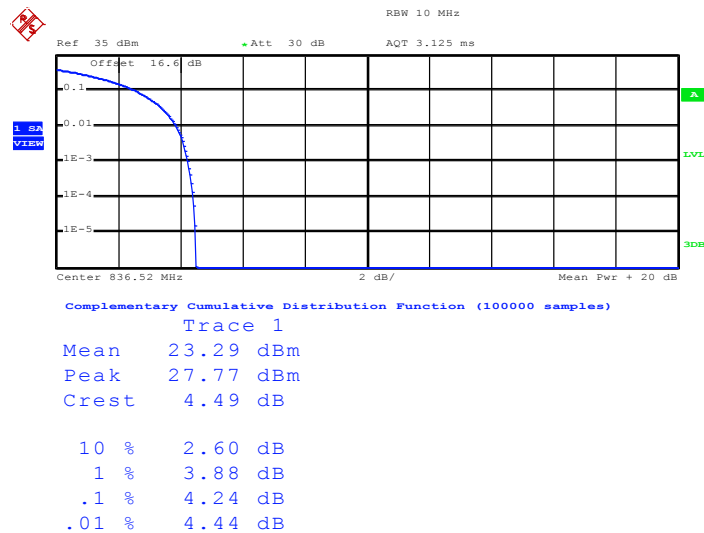

Date: 6.OCT.2014 15:53:38



Peak-to-Average Ratio on Channel 777 (848.31 MHz)

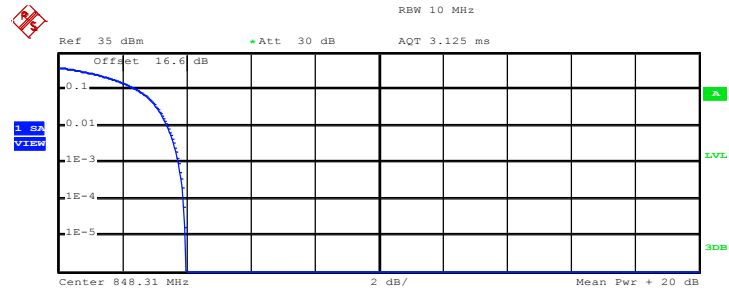

Complementary Cumulative Distribution Function (100000 samples)

Trace 1
 Mean 23.22 dBm
 Peak 27.21 dBm
 Crest 3.99 dB

10 %	2.48 dB
1 %	3.40 dB
.1 %	3.76 dB
.01 %	3.92 dB

Date: 6.OCT.2014 15:54:32



Band :	CDMA2000 BC1	Test Mode :	1xRTT Link (QPSK)
---------------	--------------	--------------------	-------------------

Peak-to-Average Ratio on Channel 25 (1851.25 MHz)

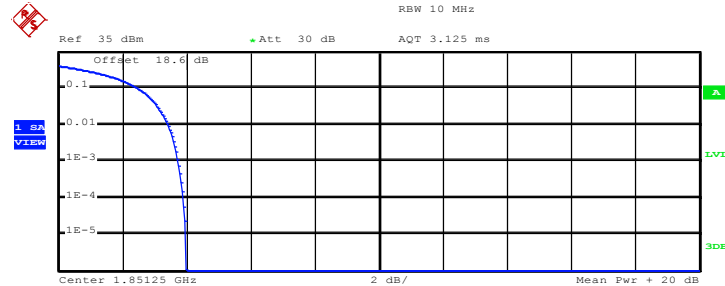

Complementary Cumulative Distribution Function (100000 samples)

Trace 1

Mean	24.50 dBm
Peak	28.48 dBm
Crest	3.98 dB
10 %	2.52 dB
1 %	3.44 dB
.1 %	3.76 dB
.01 %	3.92 dB

Date: 6.OCT.2014 17:12:43

Peak-to-Average Ratio on Channel 600 (1880 MHz)

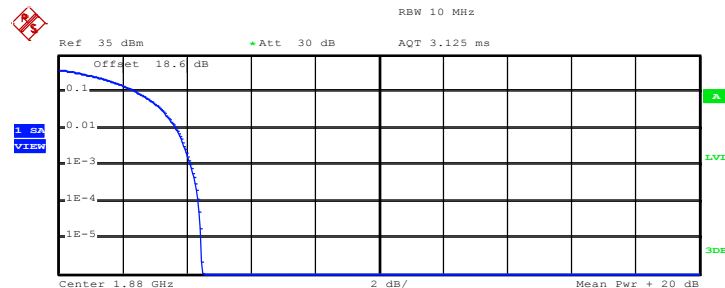

Complementary Cumulative Distribution Function (100000 samples)

Trace 1

Mean	24.78 dBm
Peak	29.26 dBm
Crest	4.48 dB
10 %	2.48 dB
1 %	3.68 dB
.1 %	4.12 dB
.01 %	4.36 dB

Date: 6.OCT.2014 17:13:12



Peak-to-Average Ratio on Channel 1175 (1908.75 MHz)

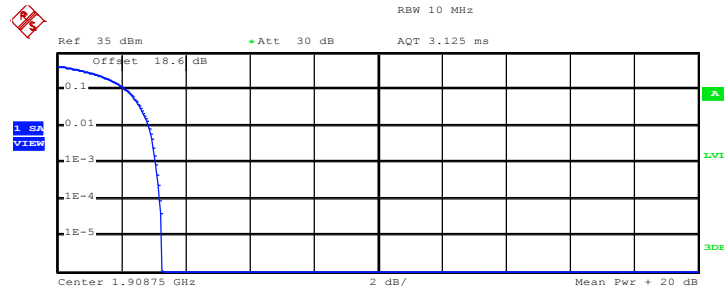

Complementary Cumulative Distribution Function (100000 samples)

Trace 1	
Mean	24.23 dBm
Peak	27.49 dBm
Crest	3.27 dB
10 %	2.16 dB
1 %	2.88 dB
.1 %	3.08 dB
.01 %	3.20 dB

Date: 6.OCT.2014 17:14:06

3.3 99% Occupied Bandwidth and 26dB Bandwidth Measurement

3.3.1 Description of 99% Occupied Bandwidth and 26dB Bandwidth Measurement

The 99% occupied bandwidth is the width of a frequency band such that, below the lower and above the upper frequency limits, the mean powers emitted are each equal to a specified percentage 0.5% of the total mean transmitted power.

The emission bandwidth is defined as the width of the signal between two points, located at the 2 sides of the carrier frequency, outside of which all emissions are attenuated at least 26 dB below the transmitter power.

3.3.2 Measuring Instruments

The measuring equipment is listed in the section 4 of this test report.

3.3.3 Test Procedures

1. The testing follows FCC KDB 971168 v02r02 Section 4.2.
2. The EUT was connected to the spectrum analyzer and system simulator via a power divider.
3. The RF output of the EUT was connected to the spectrum analyzer by RF cable and attenuator. The path loss was compensated to the results for each measurement.
4. The 99% occupied bandwidth were measured, set RBW= 1% of span, VBW= 3*RBW, sample detector, trace maximum hold.
5. The 26dB bandwidth were measured, set RBW= 1% of EBW, VBW= 3*RBW, peak detector, trace maximum hold.

3.3.4 Test Setup

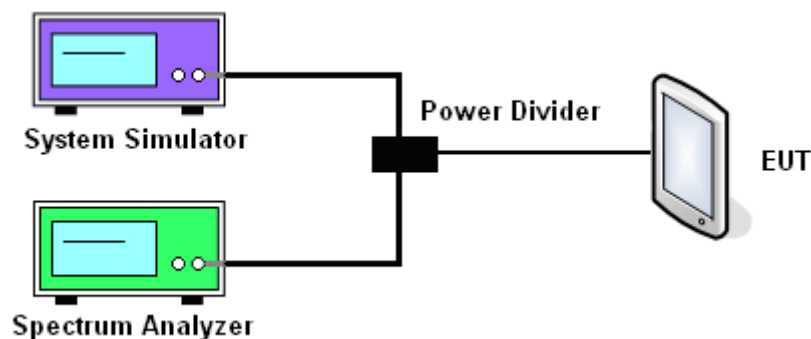



3.3.5 Test Result of Occupied Bandwidth and 26dB Bandwidth

CDMA2000 BC0			
Test Mode	CDMA 2000 1xRTT		
Test Status	RC1+SO55		
Channel	1013 (Low)	384 (Mid)	777 (High)
Frequency (MHz)	824.70	836.52	848.31
99% OBW (MHz)	1.28	1.27	1.28
26dB BW (MHz)	1.41	1.41	1.42

CDMA2000 BC1			
Test Mode	CDMA 2000 1xEV-DO Rev. 0		
Test Status	RTAP 153.6K		
Channel	25 (Low)	600 (Mid)	1175 (High)
Frequency (MHz)	1851.25	1880.00	1908.75
99% OBW (MHz)	1.28	1.27	1.28
26dB BW (MHz)	1.42	1.42	1.44



3.3.6 Test Result (Plots) of Occupied Bandwidth and 26dB Bandwidth

Band :	CDMA2000 BC0	Test Mode :	1xRTT_RC1+SO55 (QPSK)
--------	--------------	-------------	-----------------------

99% Occupied Bandwidth Plot on Channel 1013 (824.7 MHz)

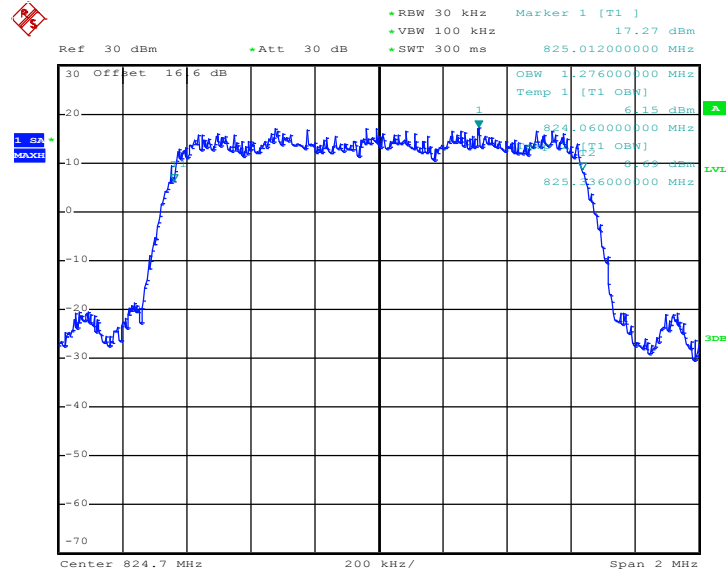

Date: 6.OCT.2014 16:47:59

26dB Bandwidth Plot on Channel 1013 (824.7 MHz)

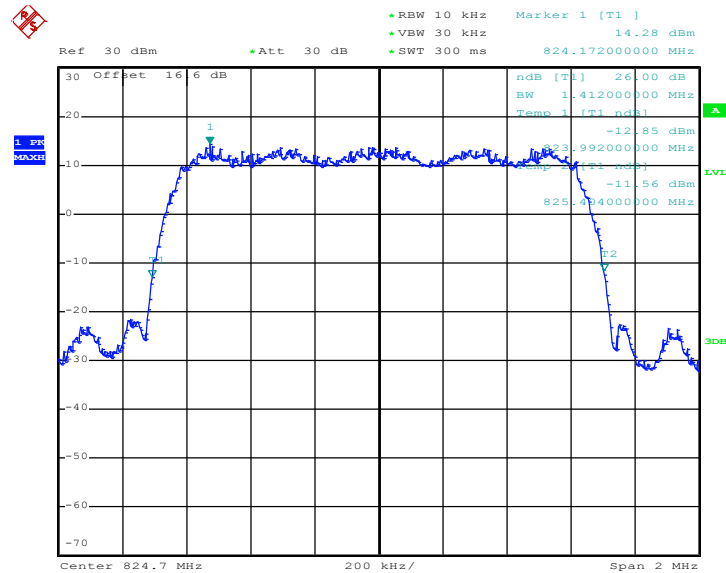

Date: 6.OCT.2014 16:40:23



99% Occupied Bandwidth Plot on Channel 384 (836.52 MHz)

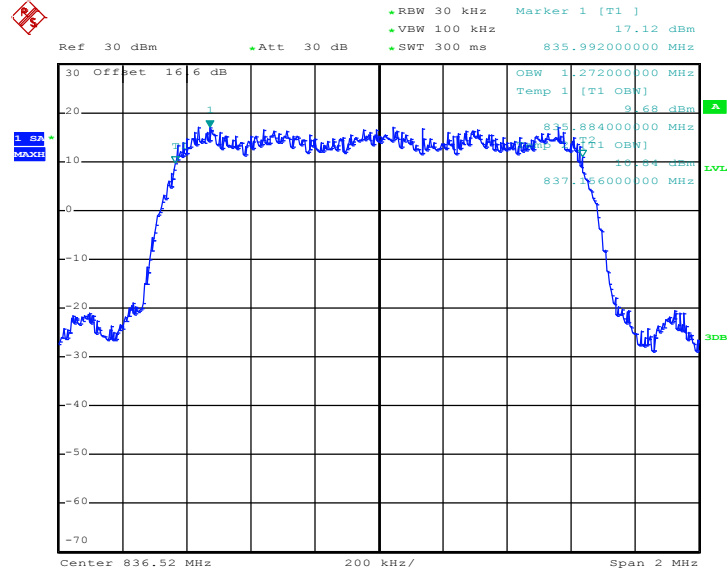

Date: 6.OCT.2014 16:48:34

26dB Bandwidth Plot on Channel 384 (836.52 MHz)

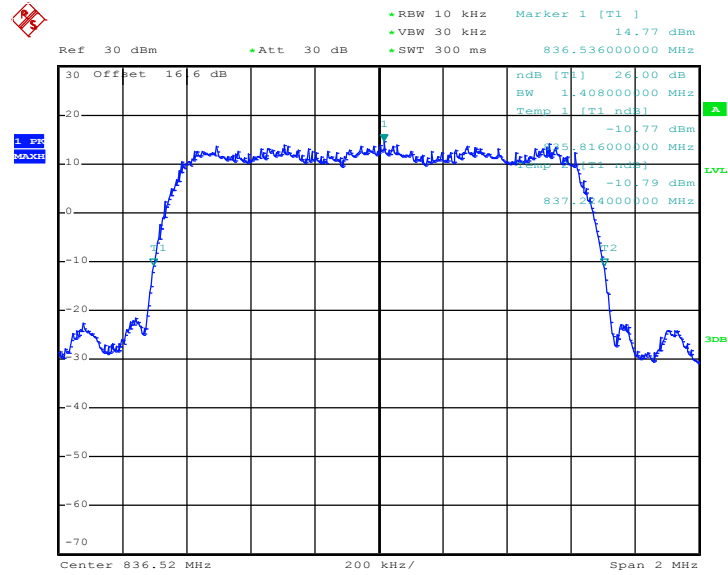

Date: 6.OCT.2014 16:41:03



99% Occupied Bandwidth Plot on Channel 777 (848.31 MHz)

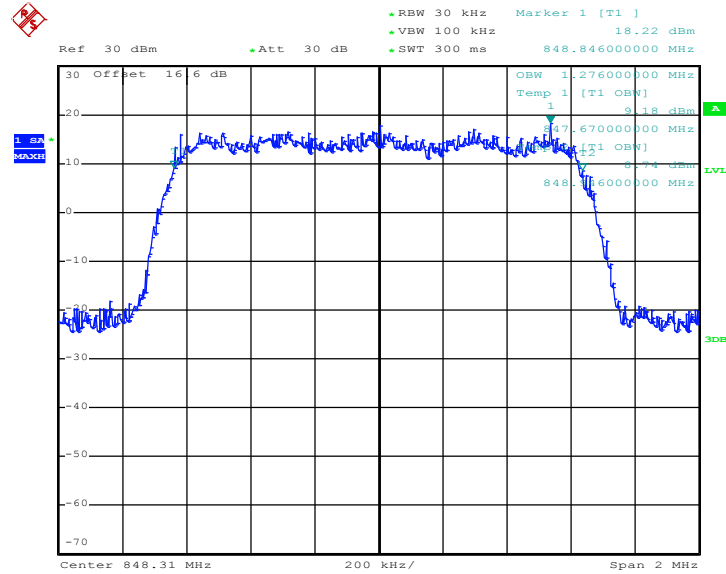

Date: 6.OCT.2014 16:49:19

26dB Bandwidth Plot on Channel 777 (848.31 MHz)

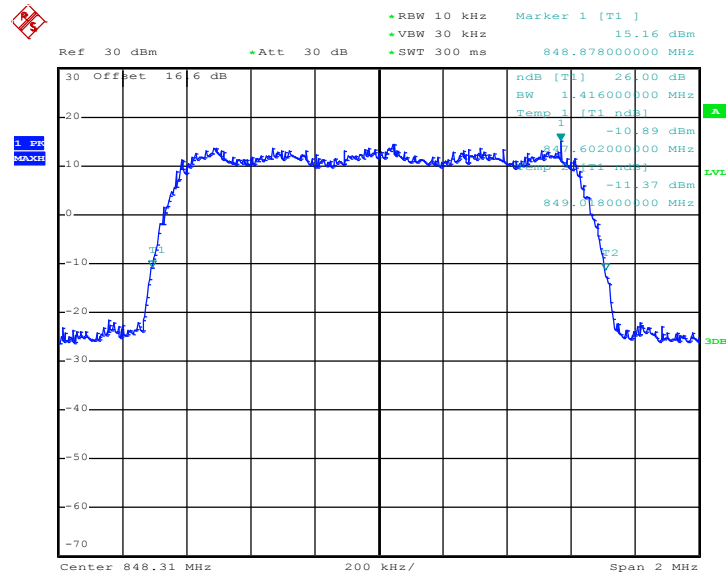

Date: 6.OCT.2014 16:41:39



Band :	CDMA2000 BC1	Test Mode :	1xEV-DO Rev. 0_RTAP 153.6K (QPSK)
--------	--------------	-------------	-----------------------------------

99% Occupied Bandwidth Plot on Channel 25 (1851.25 MHz)

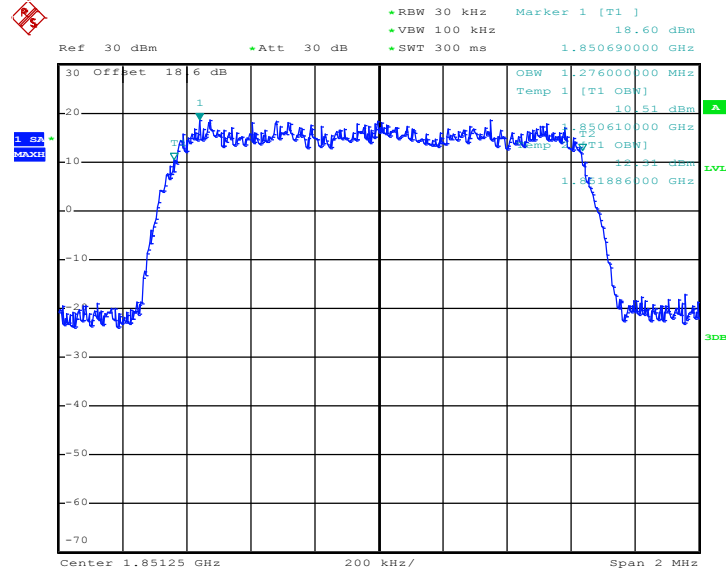

Date: 6.OCT.2014 17:32:12

26dB Bandwidth Plot on Channel 25 (1851.25 MHz)

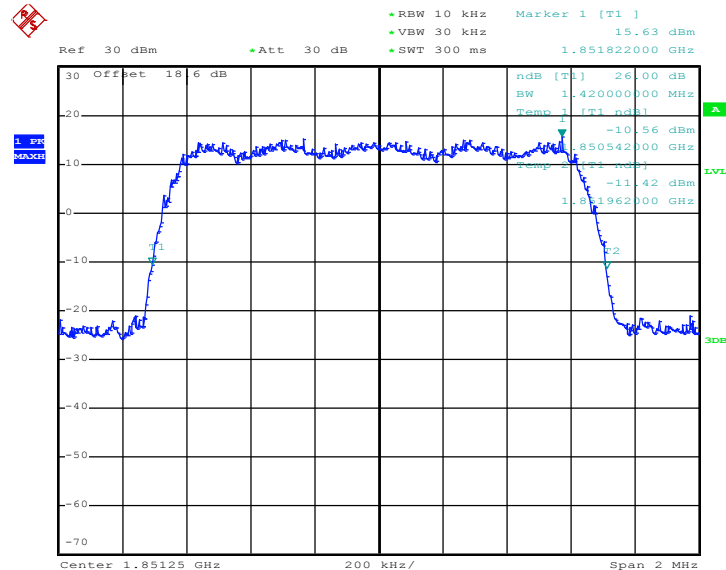

Date: 6.OCT.2014 17:29:14



99% Occupied Bandwidth Plot on Channel 600 (1880.0 MHz)

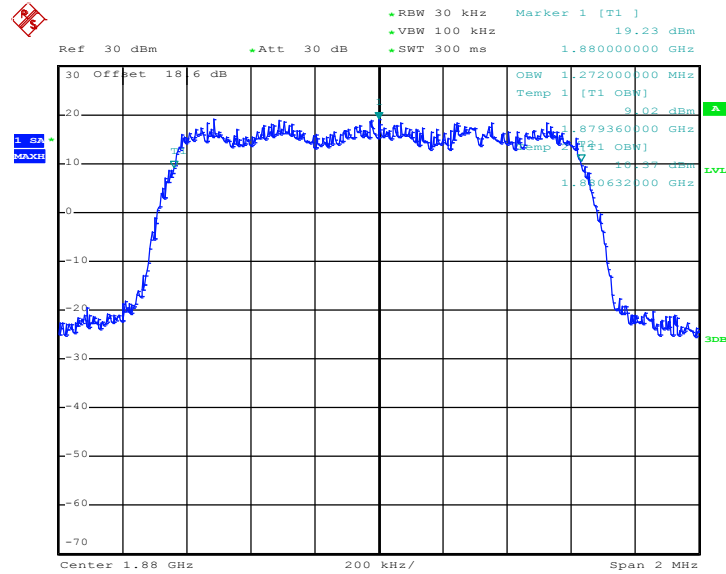

Date: 6.OCT.2014 17:32:45

26dB Bandwidth Plot on Channel 600 (1880.0 MHz)

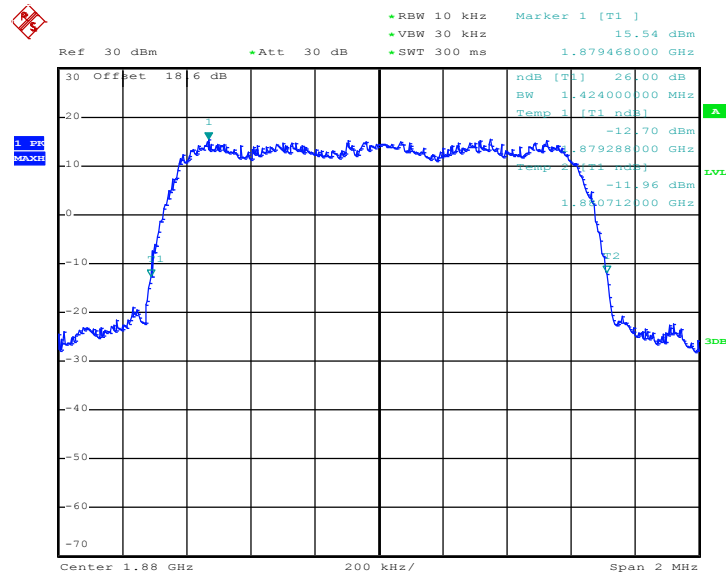

Date: 6.OCT.2014 17:29:47



99% Occupied Bandwidth Plot on Channel 1175 (1908.75 MHz)

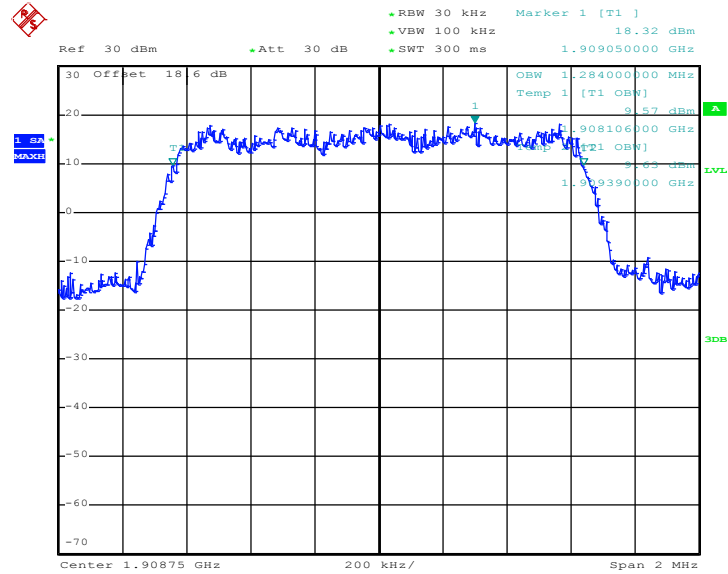

Date: 6.OCT.2014 17:33:19

26dB Bandwidth Plot on Channel 1175 (1908.75 MHz)

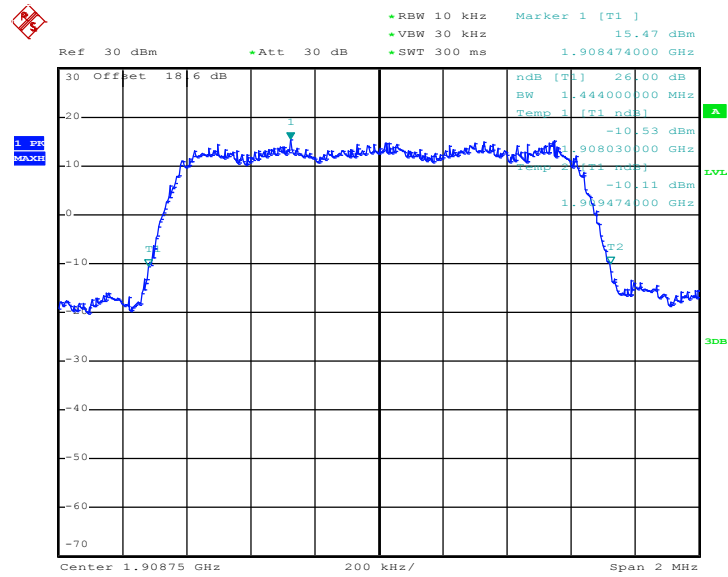

Date: 6.OCT.2014 17:30:30



3.4 Band Edge Measurement

3.4.1 Description of Band Edge Measurement

The power of any emission outside of the authorized operating frequency ranges must be lower than the transmitter power (P) by a factor of at least $43 + 10 \log (P)$ dB.

3.4.2 Measuring Instruments

The measuring equipment is listed in the section 4 of this test report.

3.4.3 Test Procedures

1. The testing follows FCC KDB 971168 v02r02 Section 6.0.
2. The EUT was connected to the spectrum analyzer and system simulator via a power divider.
3. The RF output of EUT was connected to the spectrum analyzer by an RF cable and attenuator. The path loss was compensated to the results for each measurement.
4. The band edges of low and high channels for the highest RF powers were measured.
5. The RBW was replaced by 10 kHz, slightly smaller than the value in (2), due to the spectrum analyzer limitation to set the exact value. A worst case correction factor of $10 \cdot \log (1\% \text{ emission-BW/measurement RBW})$ was compensated.
6. The RF fundamental frequency should be excluded against the limit line in the operating frequency band.
7. The limit line is derived from $43 + 10\log(P)$ dB below the transmitter power P(Watts)
= $P(W) - [43 + 10\log(P)]$ (dB)
= $[30 + 10\log(P)]$ (dBm) - $[43 + 10\log(P)]$ (dB)
= -13dBm.

3.4.4 Test Setup

<Conducted Band Edge >

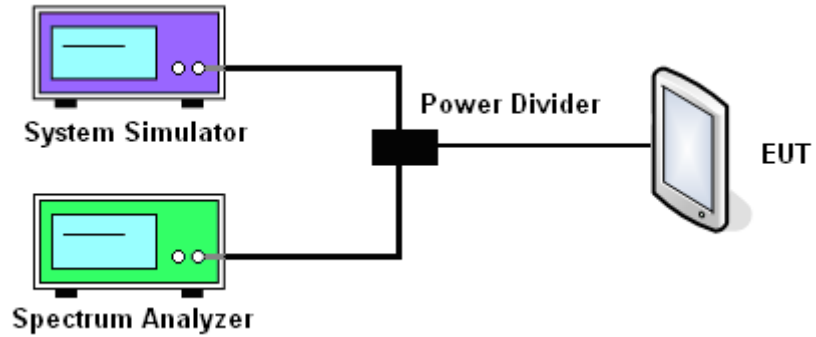



3.4.5 Test Result (Plots) of Conducted Band Edge

Band :	CDMA2000 BC0	Test Mode :	1xRTT_RC1+SO55 (QPSK)
---------------	--------------	--------------------	-----------------------

Lower Band Edge Plot on Channel 1013 (824.7 MHz)

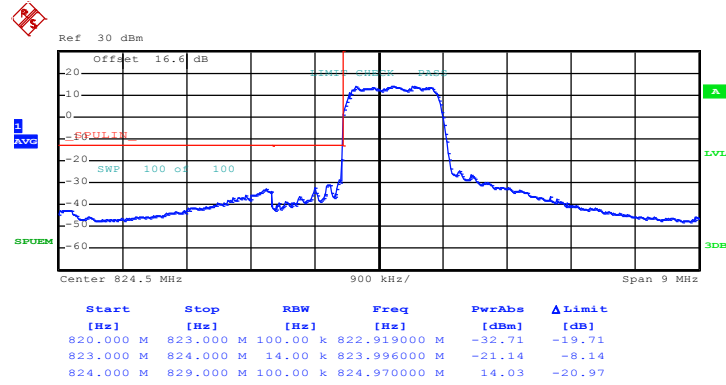

Date: 6.OCT.2014 16:25:07



Band :	CDMA2000 BC0	Test Mode :	1xRTT_RC1+SO55 (QPSK)
---------------	--------------	--------------------	-----------------------

Higher Band Edge Plot on Channel 777 (848.31 MHz)

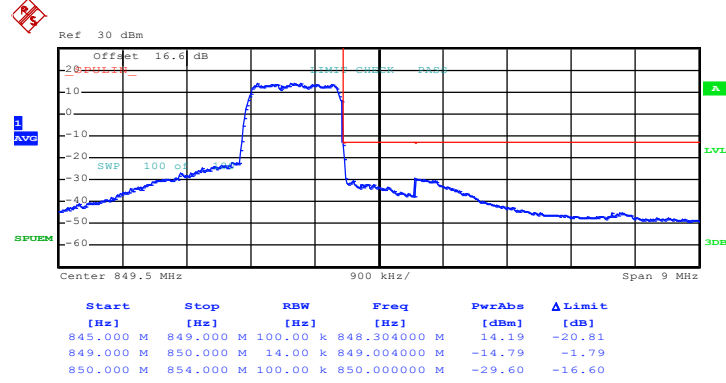

Date: 6.OCT.2014 15:58:41



Band :	CDMA2000 BC1	Test Mode :	1xEV-DO Rev. 0_RTAP 153.6K (QPSK)
--------	--------------	-------------	-----------------------------------

Lower Band Edge Plot on Channel 25 (1851.25 MHz)

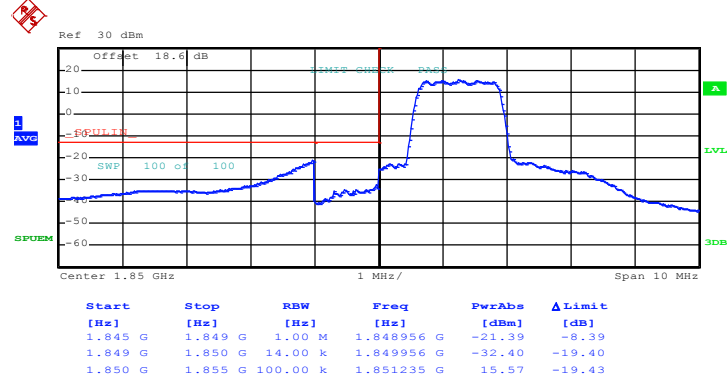

Date: 6.OCT.2014 17:26:42



Band :	CDMA2000 BC1	Test Mode :	1xEV-DO Rev. 0_RTAP 153.6K (QPSK)
---------------	--------------	--------------------	-----------------------------------

Higher Band Edge Plot on Channel 1175 (1908.75 MHz)

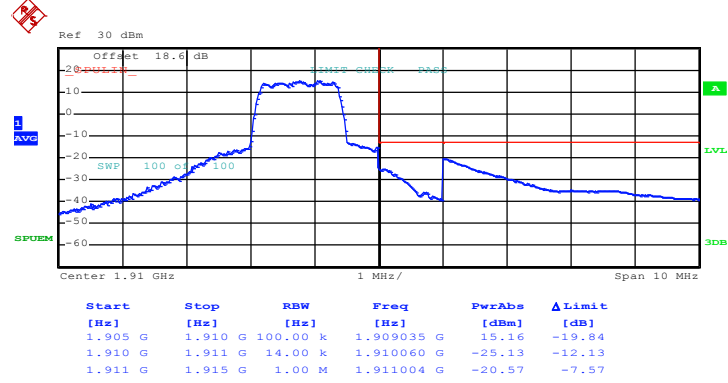

Date: 6.OCT.2014 17:17:25

3.5 Conducted Spurious Emission Measurement

3.5.1 Description of Conducted Spurious Emission Measurement

The power of any emission outside of the authorized operating frequency ranges must be lower than the transmitter power (P) by a factor of at least $43 + 10 \log (P)$ dB.

It is measured by means of a calibrated spectrum analyzer and scanned from 30 MHz up to a frequency including its 10th harmonic.

3.5.2 Measuring Instruments

The measuring equipment is listed in the section 4 of this test report.

3.5.3 Test Procedures

1. The testing follows FCC KDB 971168 v02r02 Section 6.0.
2. The EUT was connected to the spectrum analyzer and system simulator via a power divider.
3. The RF output of EUT was connected to the spectrum analyzer by an RF cable and attenuator. The path loss was compensated to the results for each measurement.
4. The middle channel for the highest RF power within the transmitting frequency was measured.
5. The conducted spurious emission for the whole frequency range was taken.
6. The RF fundamental frequency should be excluded against the limit line in the operating frequency band.
7. The limit line is derived from $43 + 10\log(P)$ dB below the transmitter power P(Watts)
 $= P(W) - [43 + 10\log(P)]$ (dB)
 $= [30 + 10\log(P)]$ (dBm) - $[43 + 10\log(P)]$ (dB)
 $= -13\text{dBm}$.

3.5.4 Test Setup

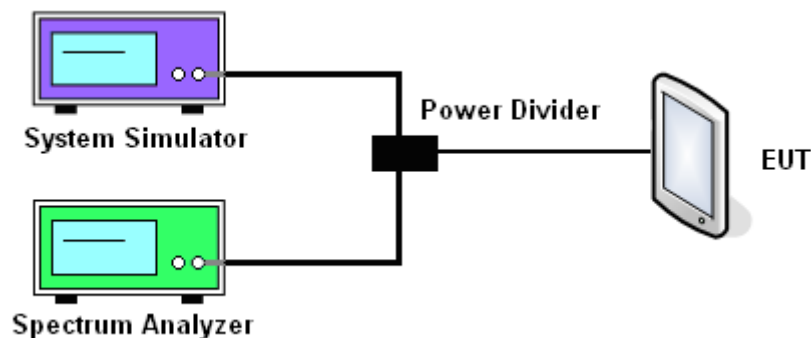



3.5.5 Test Result (Plots) of Conducted Spurious Emission

<Low Channel>

Band :	CDMA2000 BC0	Channel :	CH1013
Test Mode :	1xRTT_RC1+SO55 (QPSK)	Frequency :	824.70 MHz

Conducted Spurious Emission Plot between 30MHz ~ 1GHz

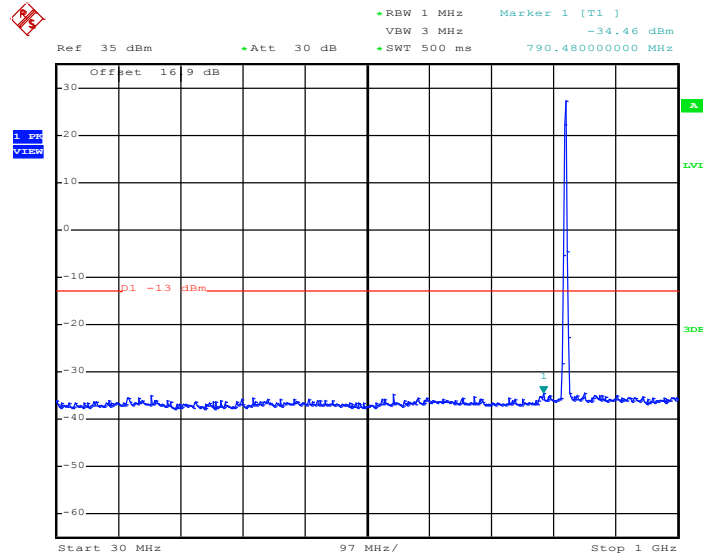

Date: 6.OCT.2014 16:51:35

Conducted Spurious Emission Plot between 1GHz ~ 3GHz

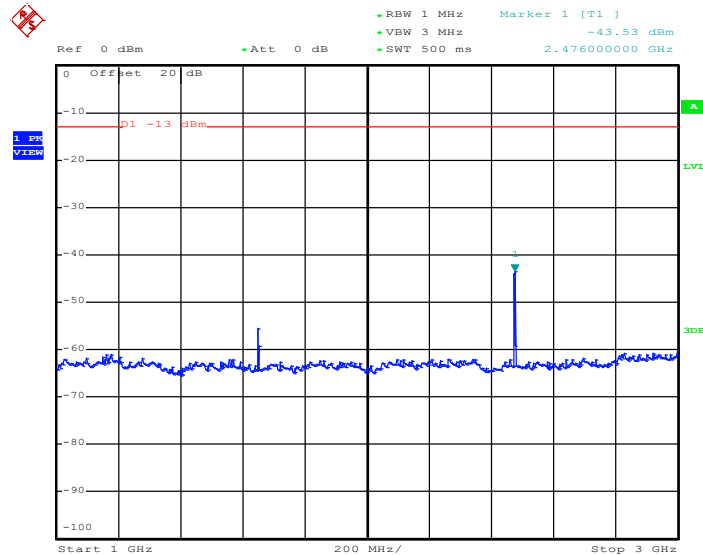

Date: 6.OCT.2014 16:51:37



Conducted Spurious Emission Plot between 3GHz ~ 7GHz

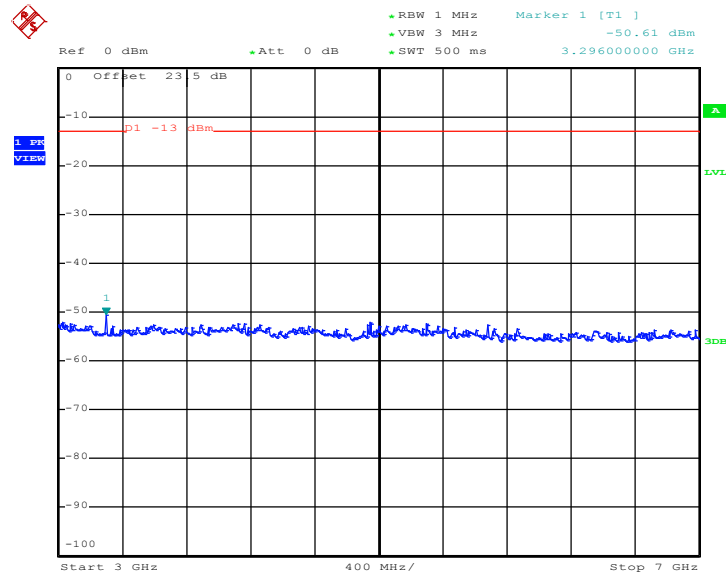

Date: 6.OCT.2014 16:51:46

Conducted Spurious Emission Plot between 7GHz ~ 9GHz

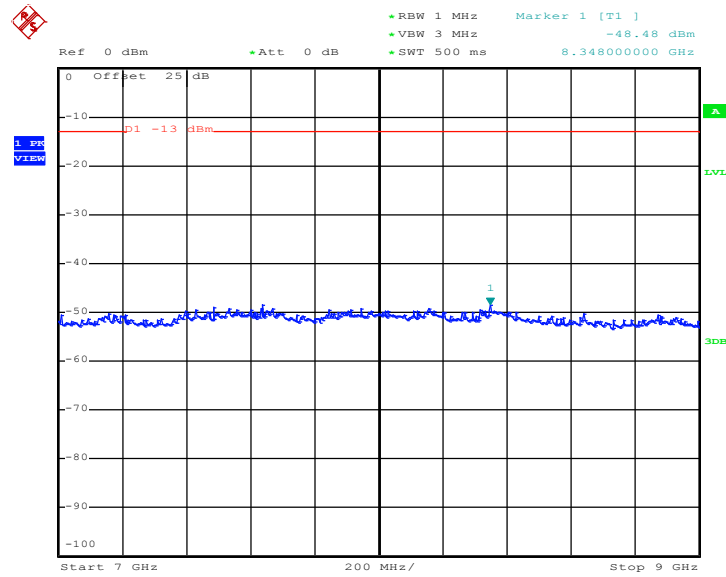

Date: 6.OCT.2014 16:51:54



<Middle Channel>

Band :	CDMA2000 BC0	Channel :	CH384
Test Mode :	1xRTT_RC1+SO55 (QPSK)	Frequency :	836.52 MHz

Conducted Spurious Emission Plot between 30MHz ~ 1GHz

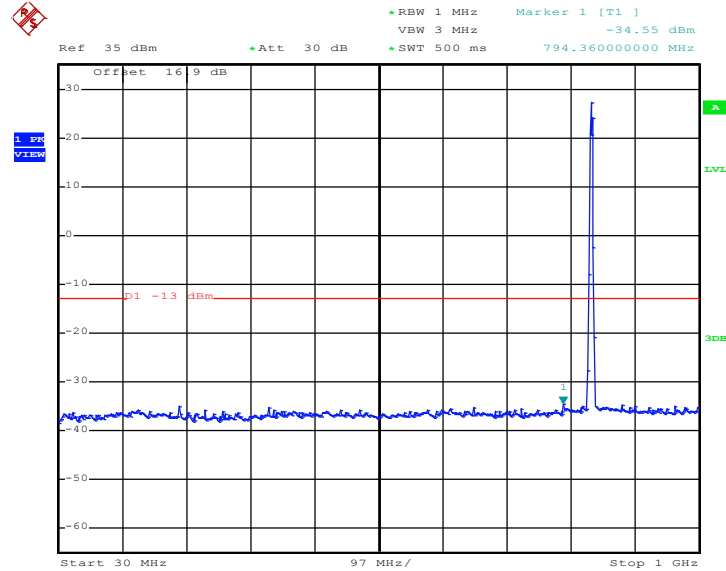

Date: 6.OCT.2014 16:52:18

Conducted Spurious Emission Plot between 1GHz ~ 3GHz

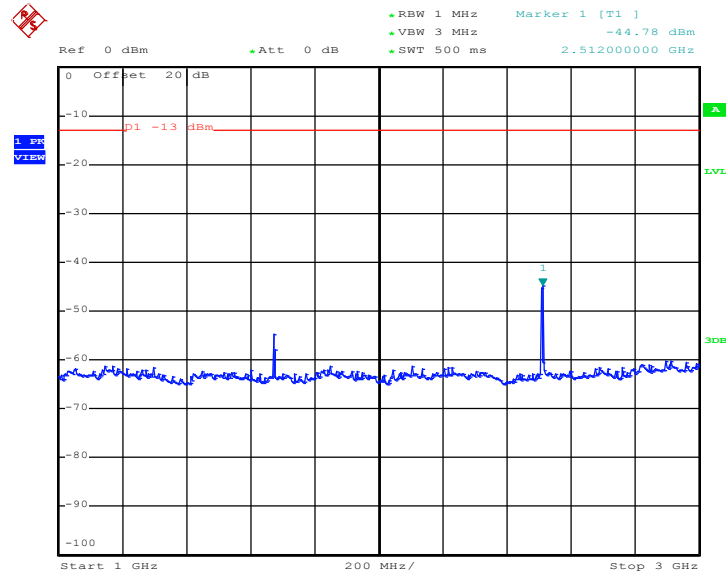

Date: 6.OCT.2014 16:52:57



Conducted Spurious Emission Plot between 3GHz ~ 7GHz

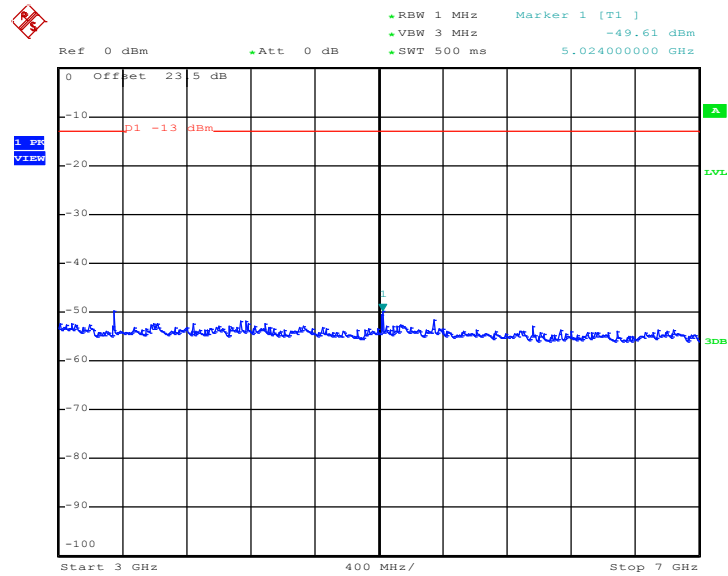

Date: 6.OCT.2014 16:53:06

Conducted Spurious Emission Plot between 7GHz ~ 9GHz

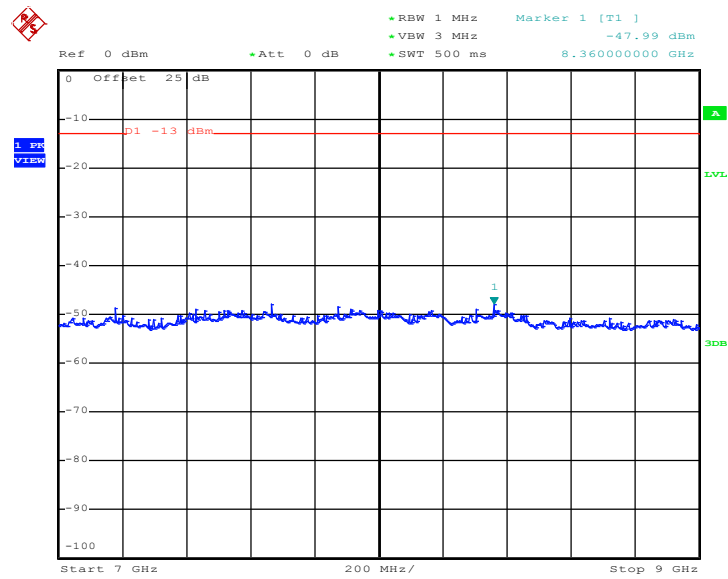

Date: 6.OCT.2014 16:53:14



<High Channel>

Band :	CDMA2000 BC0	Channel :	CH777
Test Mode :	1xRTT_RC1+SO55 (QPSK)	Frequency :	848.31 MHz

Conducted Spurious Emission Plot between 30MHz ~ 1GHz

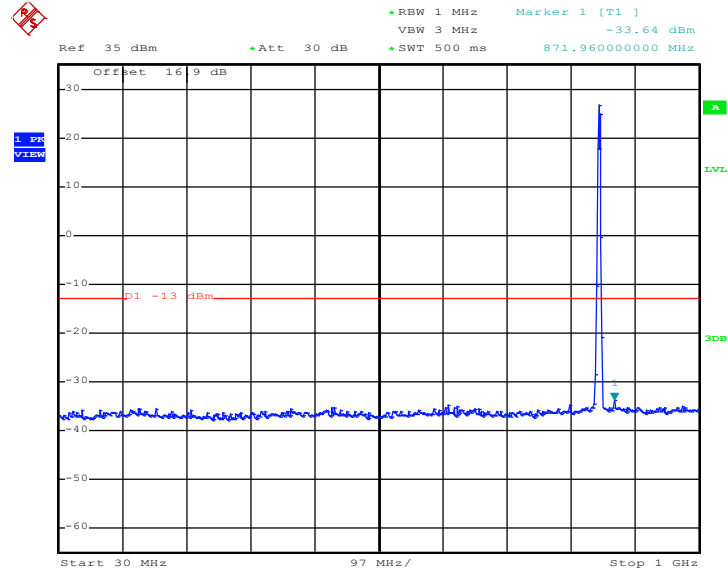

Date: 6.OCT.2014 16:53:53

Conducted Spurious Emission Plot between 1GHz ~ 3GHz

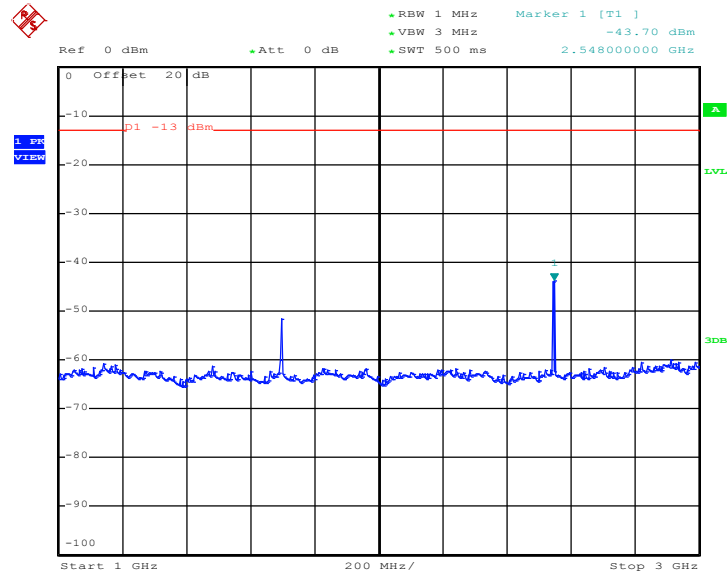

Date: 6.OCT.2014 16:54:06



Conducted Spurious Emission Plot between 3GHz ~ 7GHz

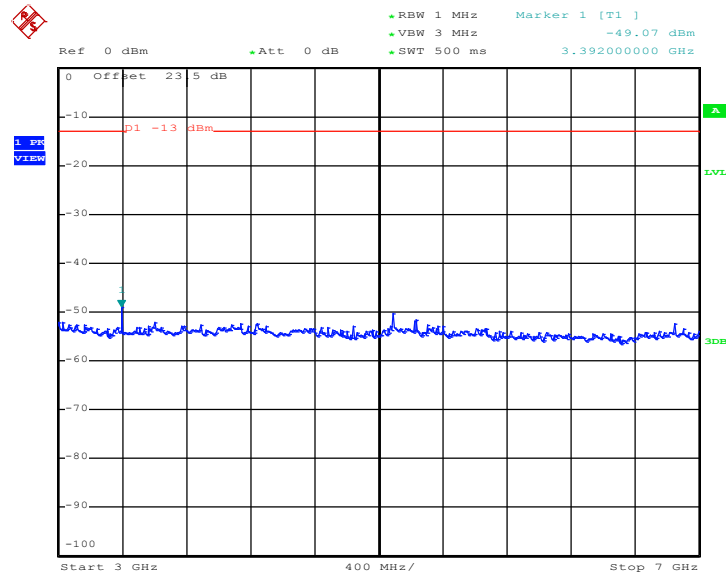

Date: 6.OCT.2014 16:54:14

Conducted Spurious Emission Plot between 7GHz ~ 9GHz

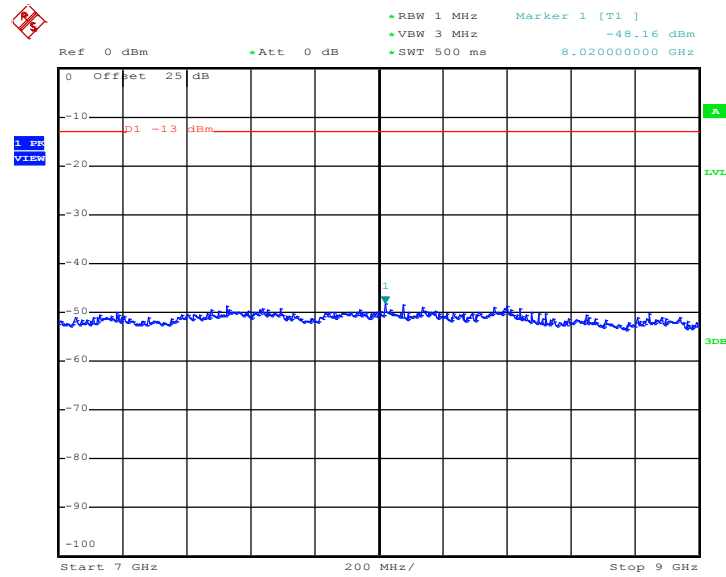

Date: 6.OCT.2014 16:54:23



<Low Channel>

Band :	CDMA2000 BC1	Channel :	CH25
Test Mode :	1xEV-DO Rev. 0_RTAP 153.6K (QPSK)	Frequency :	1851.25 MHz

Conducted Spurious Emission Plot between 30MHz ~ 1GHz

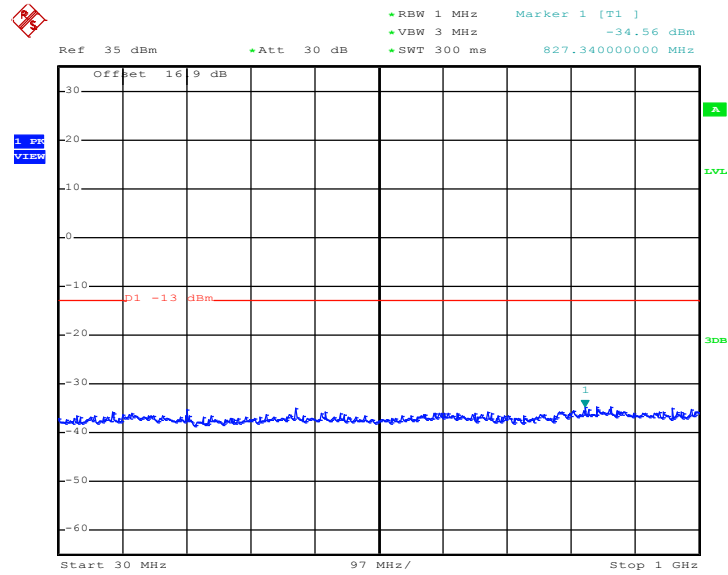

Date: 6.OCT.2014 17:34:35

Conducted Spurious Emission Plot between 1GHz ~ 3GHz

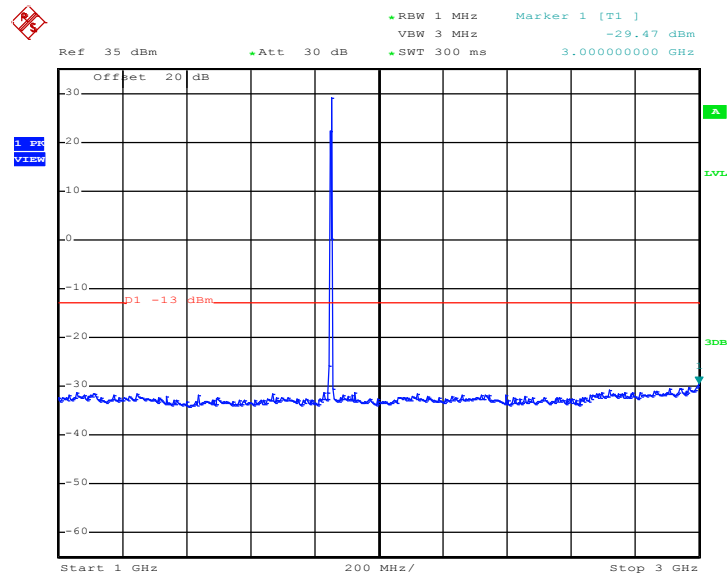

Date: 6.OCT.2014 17:34:11



Conducted Spurious Emission Plot between 3GHz ~ 7GHz

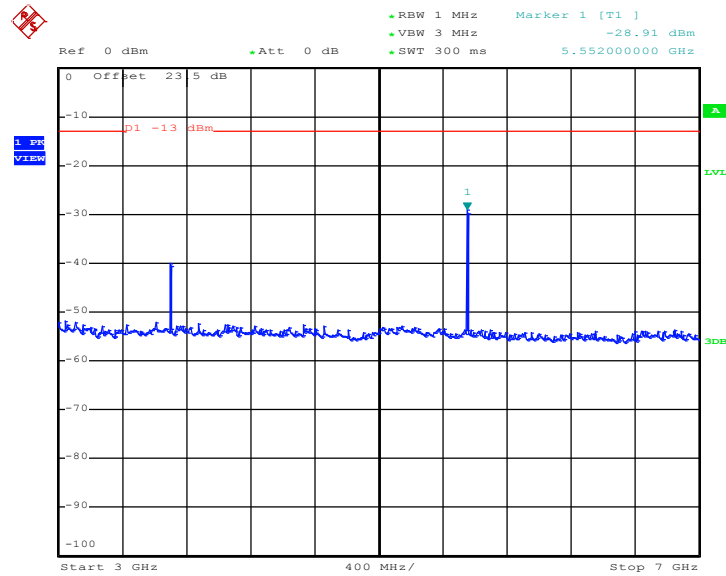

Date: 6.OCT.2014 17:34:54

Conducted Spurious Emission Plot between 7GHz ~ 13.6GHz

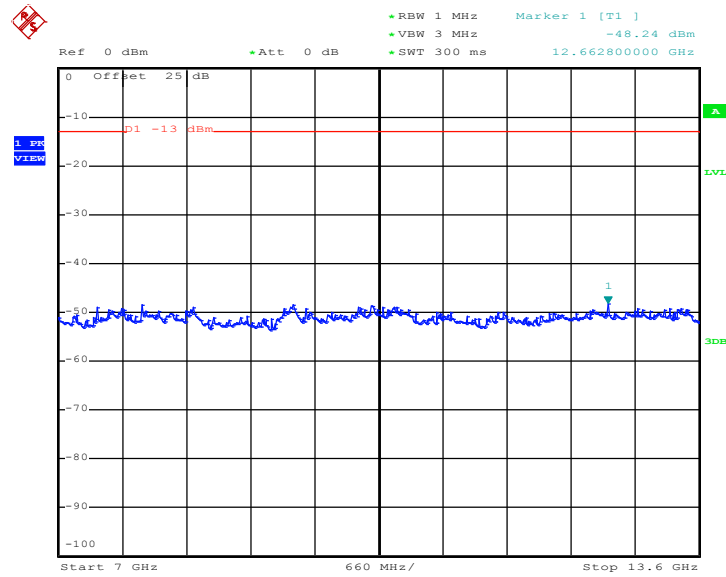

Date: 6.OCT.2014 17:35:02



Conducted Spurious Emission Plot between 13.6GHz ~ 19.1GHz

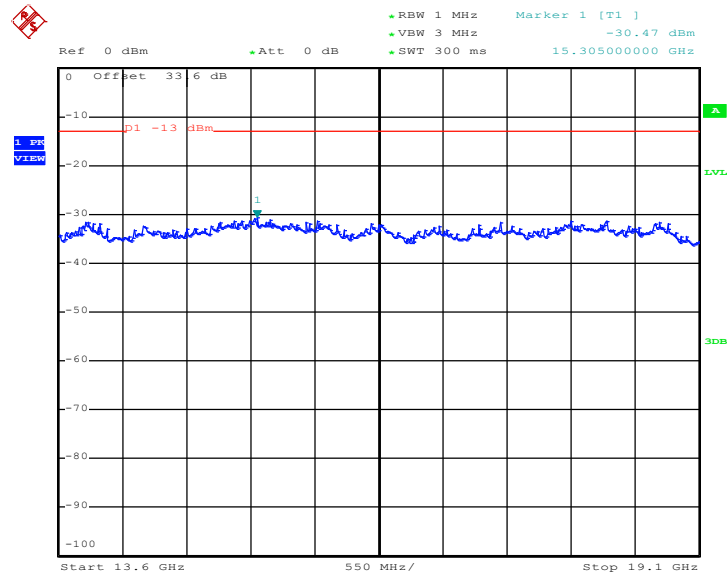

Date: 6.OCT.2014 17:35:11



<Middle Channel>

Band :	CDMA2000 BC1	Channel :	CH600
Test Mode :	1xEV-DO Rev. 0_RTAP 153.6K (QPSK)	Frequency :	1880.0 MHz

Conducted Spurious Emission Plot between 30MHz ~ 1GHz

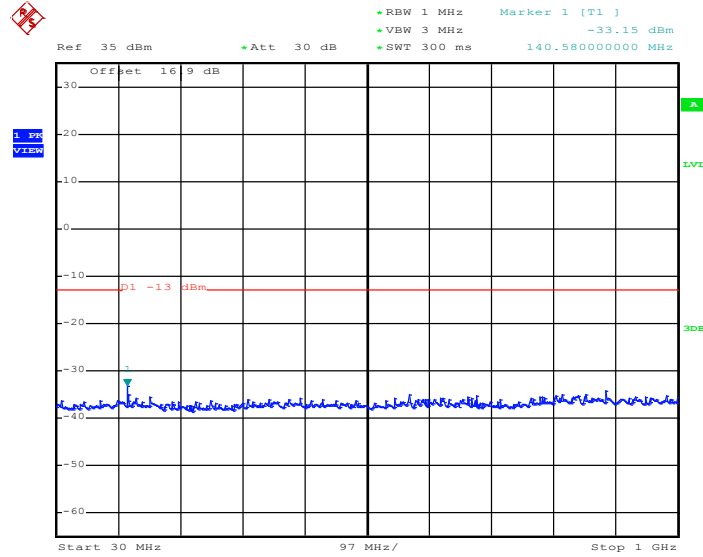

Date: 6.OCT.2014 17:43:22

Conducted Spurious Emission Plot between 1GHz ~ 3GHz

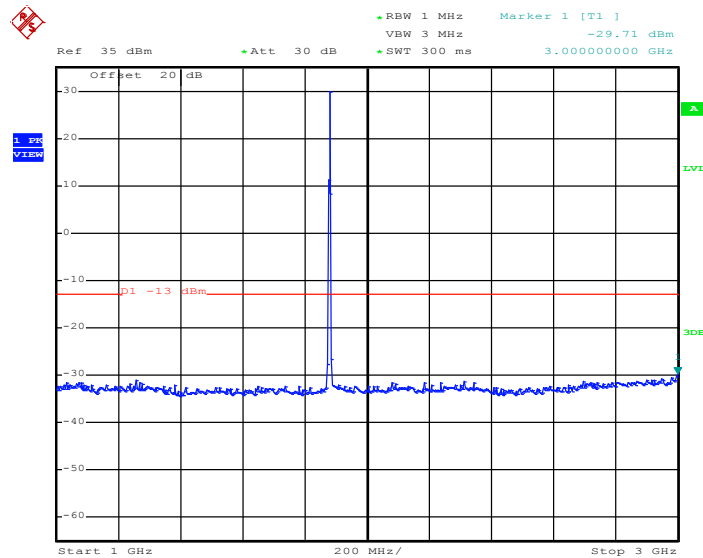

Date: 6.OCT.2014 17:43:08



Conducted Spurious Emission Plot between 3GHz ~ 7GHz

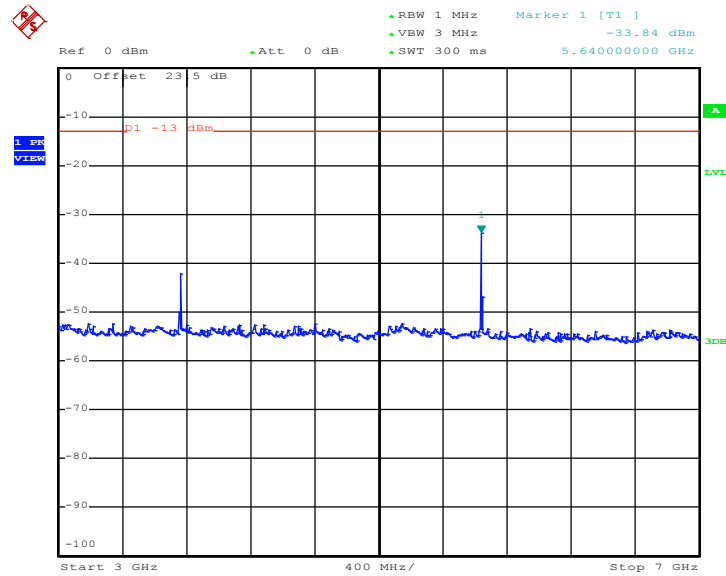

Date: 6.OCT.2014 17:43:58

Conducted Spurious Emission Plot between 7GHz ~ 13.6GHz

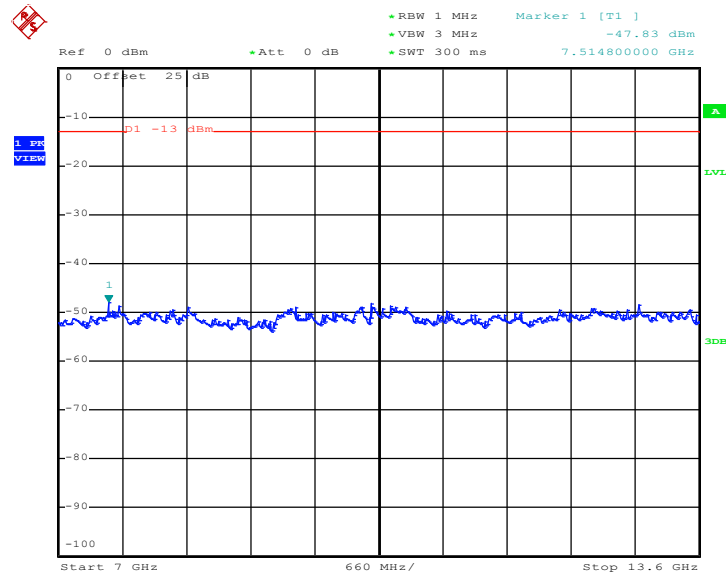

Date: 6.OCT.2014 17:44:06



Conducted Spurious Emission Plot between 13.6GHz ~ 19.1GHz

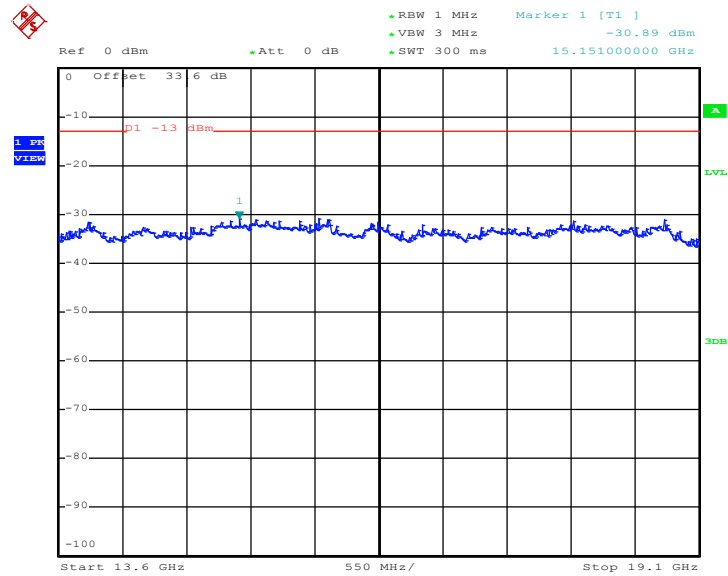

Date: 6.OCT.2014 17:44:15



<High Channel>

Band :	CDMA2000 BC1	Channel :	CH600
Test Mode :	1xEV-DO Rev. 0_RTAP 153.6K (QPSK)	Frequency :	1880.0 MHz

Conducted Spurious Emission Plot between 30MHz ~ 1GHz

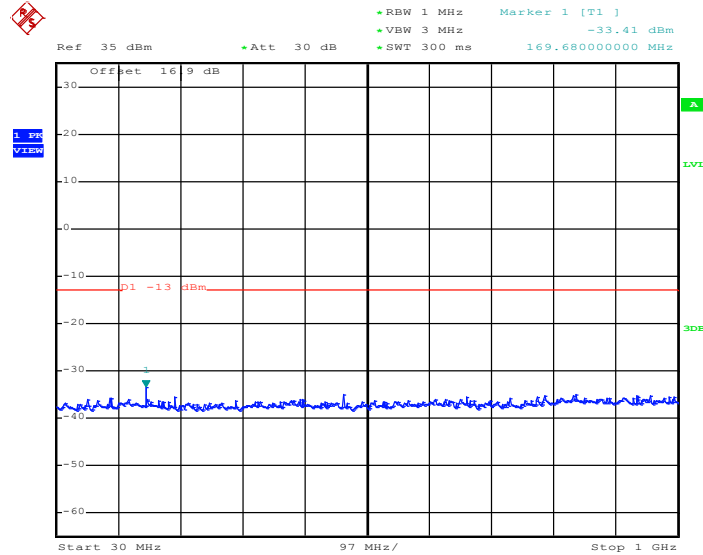

Date: 6.OCT.2014 17:45:16

Conducted Spurious Emission Plot between 1GHz ~ 3GHz

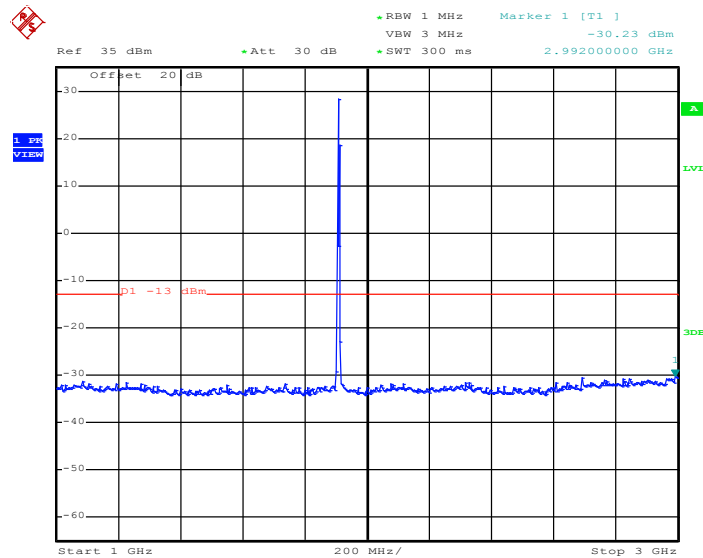

Date: 6.OCT.2014 17:46:07



Conducted Spurious Emission Plot between 3GHz ~ 7GHz

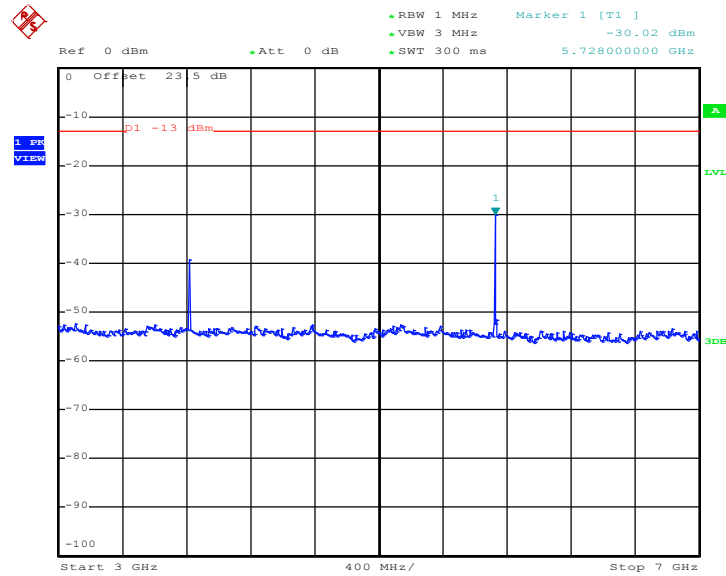

Date: 6.OCT.2014 17:45:37

Conducted Spurious Emission Plot between 7GHz ~ 13.6GHz

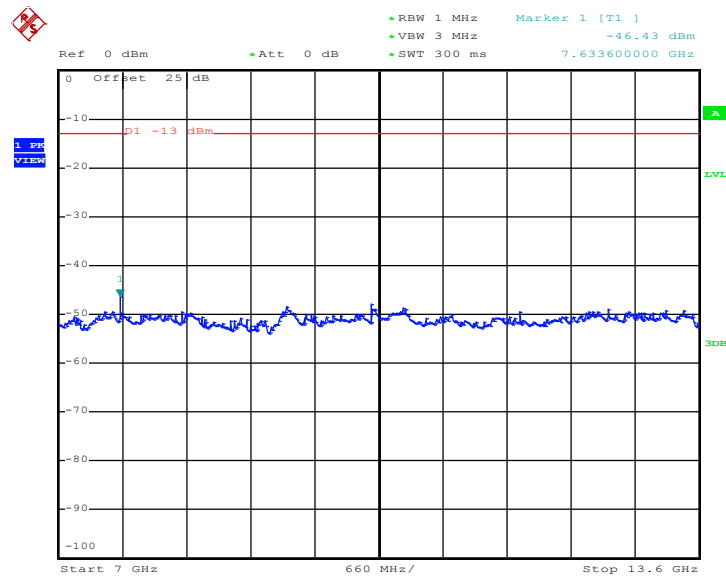

Date: 6.OCT.2014 17:45:45



Conducted Spurious Emission Plot between 13.6GHz ~ 19.1GHz

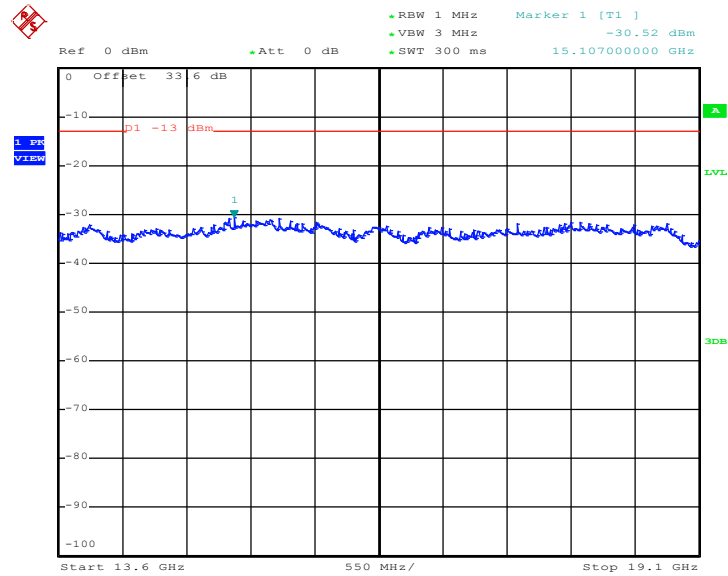

Date: 6.OCT.2014 17:45:54



3.6 Field Strength of Spurious Radiation Measurement

3.6.1 Description of Field Strength of Spurious Radiated Measurement

The power of any emission outside of the authorized operating frequency ranges must be attenuated below the transmitter power (P) by a factor of at least $43 + 10 \log (P)$ dB. The spectrum is scanned from 30 MHz up to a frequency including its 10th harmonic.

3.6.2 Measuring Instruments

The measuring equipment is listed in the section 4 of this test report.

3.6.3 Test Procedures

1. The testing follows FCC KDB 971168 v02r02 Section 5.8 and ANSI / TIA-603-C-2004 Section 2.2.12.
2. The EUT was placed on a rotatable wooden table 0.8 meters above the ground.
3. The EUT was set 3 meters from the receiving antenna, which was mounted on the antenna tower.
4. The table was rotated 360 degrees to determine the position of the highest spurious emission.
5. The height of the receiving antenna is varied between one meter and four meters to search for the maximum spurious emission for both horizontal and vertical polarizations.
6. Make the measurement with the spectrum analyzer's RBW = 1MHz, VBW = 3MHz, taking record of maximum spurious emission.
7. A horn antenna was substituted in place of the EUT and was driven by a signal generator.
8. Tune the output power of signal generator to the same emission level with EUT maximum spurious emission.
9. Taking the record of output power at antenna port.
10. Repeat step 7 to step 8 for another polarization.
11. $EIRP (dBm) = S.G. Power - Tx Cable Loss + Tx Antenna Gain$
12. $ERP (dBm) = EIRP - 2.15$
13. The RF fundamental frequency should be excluded against the limit line in the operating frequency band.
14. The limit line is derived from $43 + 10\log(P)$ dB below the transmitter power P(Watts)
= $P(W) - [43 + 10\log(P)] (dB)$
= $[30 + 10\log(P)] (dBm) - [43 + 10\log(P)] (dB)$
= -13dBm.

3.6.4 Test Setup

For radiated emissions from 30MHz to 1GHz

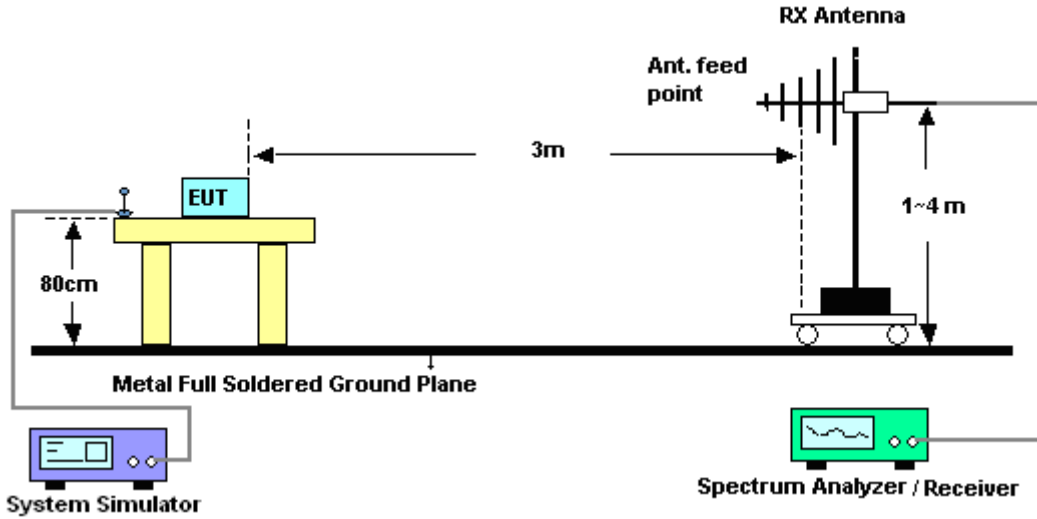

For radiated emissions above 1GHz

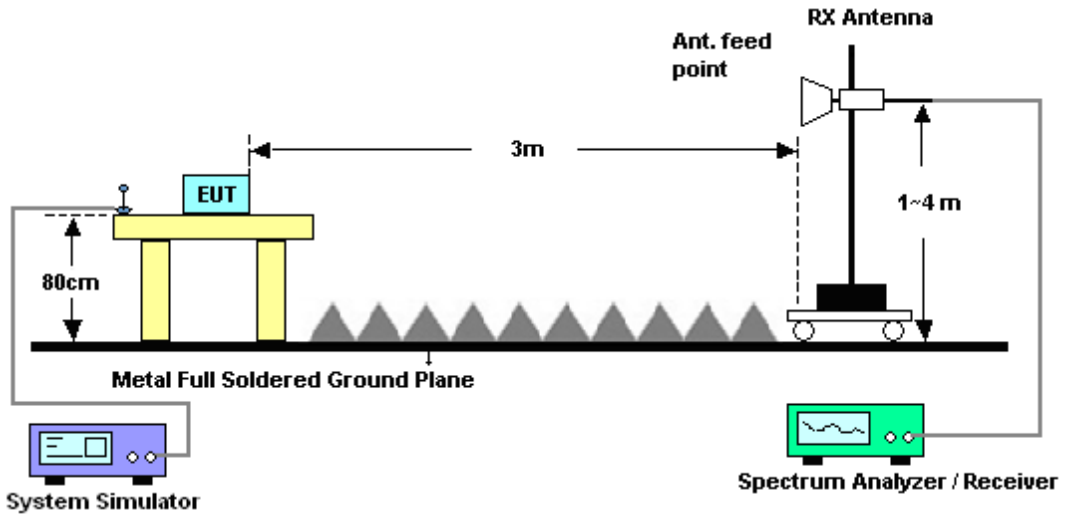



3.6.5 Test Result of Field Strength of Spurious Radiated

<Low Channel>

Band :	CDMA2000 BC0						Temperature :	20~22°C	
Test Mode :	1xRTT_RC1+SO55 (QPSK)						Relative Humidity :	47~48%	
Test Engineer :	Stan Hsieh, Eric Shih, and Derreck Chen						Polarization :	Horizontal	
Remark :	Spurious emissions within 30-1000MHz were found more than 20dB below limit line.								
Frequency (MHz)	ERP (dBm)	Limit (dBm)	Over Limit (dB)	SPA Reading (dBm)	S.G. Power (dBm)	TX Cable loss (dB)	TX Antenna Gain (dBi)	Polarization (H/V)	Result
1648	-45.76	-13	-32.76	-55.29	-47.52	0.98	4.89	H	Pass
2472	-46.91	-13	-33.91	-60.03	-48.79	1.28	5.32	H	Pass
3296	-52.34	-13	-39.34	-68.75	-55.75	1.54	7.10	H	Pass

Band :	CDMA2000 BC0						Temperature :	20~22°C	
Test Mode :	1xRTT_RC1+SO55 (QPSK)						Relative Humidity :	47~48%	
Test Engineer :	Stan Hsieh, Eric Shih, and Derreck Chen						Polarization :	Vertical	
Remark :	Spurious emissions within 30-1000MHz were found more than 20dB below limit line.								
Frequency (MHz)	ERP (dBm)	Limit (dBm)	Over Limit (dB)	SPA Reading (dBm)	S.G. Power (dBm)	TX Cable loss (dB)	TX Antenna Gain (dBi)	Polarization (H/V)	Result
1648	-44.88	-13	-31.88	-52.33	-46.64	0.98	4.89	V	Pass
2472	-46.12	-13	-33.12	-61.24	-48	1.28	5.32	V	Pass
3296	-57.46	-13	-44.46	-73.01	-60.87	1.54	7.10	V	Pass



<Middle Channel>

Band :	CDMA2000 BC0	Temperature :	20~22°C						
Test Mode :	1xRTT_RC1+SO55 (QPSK)	Relative Humidity :	47~48%						
Test Engineer :	Stan Hsieh, Eric Shih, and Derreck Chen	Polarization :	Horizontal						
Remark :	Spurious emissions within 30-1000MHz were found more than 20dB below limit line.								
Frequency (MHz)	ERP (dBm)	Limit (dBm)	Over Limit (dB)	SPA Reading (dBm)	S.G. Power (dBm)	TX Cable loss (dB)	TX Antenna Gain (dBi)	Polarization (H/V)	Result
1672	-43.10	-13	-30.10	-52.48	-44.78	0.99	4.82	H	Pass
2512	-48.29	-13	-35.29	-61.54	-50.26	1.29	5.41	H	Pass
3344	-53.20	-13	-40.20	-69.3	-56.81	1.56	7.31	H	Pass

Band :	CDMA2000 BC0	Temperature :	20~22°C						
Test Mode :	1xRTT_RC1+SO55 (QPSK)	Relative Humidity :	47~48%						
Test Engineer :	Stan Hsieh, Eric Shih, and Derreck Chen	Polarization :	Vertical						
Remark :	Spurious emissions within 30-1000MHz were found more than 20dB below limit line.								
Frequency (MHz)	ERP (dBm)	Limit (dBm)	Over Limit (dB)	SPA Reading (dBm)	S.G. Power (dBm)	TX Cable loss (dB)	TX Antenna Gain (dBi)	Polarization (H/V)	Result
1672	-50.42	-13	-37.42	-57.62	-52.1	0.99	4.82	V	Pass
2512	-47.48	-13	-34.48	-62.78	-49.45	1.29	5.41	V	Pass
3344	-58.02	-13	-45.02	-73.17	-61.63	1.56	7.31	V	Pass



<High Channel>

Band :	CDMA2000 BC0						Temperature :	20~22°C		
Test Mode :	1xRTT_RC1+SO55 (QPSK)						Relative Humidity :	47~48%		
Test Engineer :	Stan Hsieh, Eric Shih, and Derreck Chen						Polarization :	Horizontal		
Remark :	Spurious emissions within 30-1000MHz were found more than 20dB below limit line.									
Frequency (MHz)	ERP (dBm)	Limit (dBm)	Over Limit (dB)	SPA Reading (dBm)	S.G. Power (dBm)	TX Cable loss (dB)	TX Antenna Gain (dBi)	Polarization (H/V)	Result	
1696	-40.60	-13	-27.60	-50.08	-42.2	1.00	4.75	H	Pass	
2544	-41.48	-13	-28.48	-55.21	-43.46	1.30	5.44	H	Pass	
3392	-49.28	-13	-36.28	-65.71	-53.08	1.57	7.52	H	Pass	
4240	-49.40	-13	-36.40	-70.72	-54	1.90	8.65	H	Pass	

Band :	CDMA2000 BC0						Temperature :	20~22°C		
Test Mode :	1xRTT_RC1+SO55 (QPSK)						Relative Humidity :	47~48%		
Test Engineer :	Stan Hsieh, Eric Shih, and Derreck Chen						Polarization :	Vertical		
Remark :	Spurious emissions within 30-1000MHz were found more than 20dB below limit line.									
Frequency (MHz)	ERP (dBm)	Limit (dBm)	Over Limit (dB)	SPA Reading (dBm)	S.G. Power (dBm)	TX Cable loss (dB)	TX Antenna Gain (dBi)	Polarization (H/V)	Result	
1696	-46.52	-13	-33.52	-54.28	-48.12	1.00	4.75	V	Pass	
2544	-42.17	-13	-29.17	-57.54	-44.15	1.30	5.44	V	Pass	
3392	-54.67	-13	-41.67	-70.52	-58.47	1.57	7.52	V	Pass	
4240	-52.22	-13	-39.22	-72.42	-56.82	1.90	8.65	V	Pass	



<Low Channel>

Band :	CDMA2000 BC1						Temperature :	20~22°C	
Test Mode :	1xEV-DO Rev. 0_RTAP 153.6K (QPSK)						Relative Humidity :	47~48%	
Test Engineer :	Stan Hsieh, Eric Shih, and Derreck Chen						Polarization :	Horizontal	
Remark :	Spurious emissions within 30-1000MHz were found more than 20dB below limit line.								
Frequency (MHz)	EIRP (dBm)	Limit (dBm)	Over Limit (dB)	SPA Reading (dBm)	S.G. Power (dBm)	TX Cable loss (dB)	TX Antenna Gain (dBi)	Polarization (H/V)	Result
3700	-39.61	-13	-26.61	-58.26	-46.18	1.67	8.24	H	Pass
5555	-33.94	-13	-20.94	-57.61	-41.01	2.66	9.72	H	Pass
7403	-41.27	-13	-28.27	-70.06	-50.42	2.46	11.61	H	Pass

Band :	CDMA2000 BC1						Temperature :	20~22°C	
Test Mode :	1xEV-DO Rev. 0_RTAP 153.6K (QPSK)						Relative Humidity :	47~48%	
Test Engineer :	Stan Hsieh, Eric Shih, and Derreck Chen						Polarization :	Vertical	
Remark :	Spurious emissions within 30-1000MHz were found more than 20dB below limit line.								
Frequency (MHz)	EIRP (dBm)	Limit (dBm)	Over Limit (dB)	SPA Reading (dBm)	S.G. Power (dBm)	TX Cable loss (dB)	TX Antenna Gain (dBi)	Polarization (H/V)	Result
3700	-44.63	-13	-31.63	-63.19	-51.2	1.67	8.24	V	Pass
5555	-36.93	-13	-23.93	-59.05	-44	2.66	9.72	V	Pass
7403	-46.31	-13	-33.31	-74.73	-55.46	2.46	11.61	V	Pass



<Middle Channel>

Band :	CDMA2000 BC1	Temperature :	20~22°C						
Test Mode :	1xEV-DO Rev. 0_RTAP 153.6K (QPSK)	Relative Humidity :	47~48%						
Test Engineer :	Stan Hsieh, Eric Shih, and Derreck Chen	Polarization :	Horizontal						
Remark :	Spurious emissions within 30-1000MHz were found more than 20dB below limit line.								
Frequency (MHz)	EIRP (dBm)	Limit (dBm)	Over Limit (dB)	SPA Reading (dBm)	S.G. Power (dBm)	TX Cable loss (dB)	TX Antenna Gain (dBi)	Polarization (H/V)	Result
3763	-35.47	-13	-22.47	-54.62	-42.1	1.69	8.32	H	Pass
5639	-28.40	-13	-15.40	-52.22	-35.45	2.71	9.76	H	Pass
7522	-42.08	-13	-29.08	-70.76	-51.47	2.42	11.81	H	Pass

Band :	CDMA2000 BC1	Temperature :	20~22°C						
Test Mode :	1xEV-DO Rev. 0_RTAP 153.6K (QPSK)	Relative Humidity :	47~48%						
Test Engineer :	Stan Hsieh, Eric Shih, and Derreck Chen	Polarization :	Vertical						
Remark :	Spurious emissions within 30-1000MHz were found more than 20dB below limit line.								
Frequency (MHz)	EIRP (dBm)	Limit (dBm)	Over Limit (dB)	SPA Reading (dBm)	S.G. Power (dBm)	TX Cable loss (dB)	TX Antenna Gain (dBi)	Polarization (H/V)	Result
3763	-38.43	-13	-25.43	-57.06	-45.06	1.69	8.32	V	Pass
5639	-32.98	-13	-19.98	-55.27	-40.03	2.71	9.76	V	Pass
7522	-46.55	-13	-33.55	-74.84	-55.94	2.42	11.81	V	Pass



<High Channel>

Band :	CDMA2000 BC1						Temperature :	20~22°C	
Test Mode :	1xEV-DO Rev. 0_RTAP 153.6K (QPSK)						Relative Humidity :	47~48%	
Test Engineer :	Stan Hsieh, Eric Shih, and Derreck Chen						Polarization :	Horizontal	
Remark :	Spurious emissions within 30-1000MHz were found more than 20dB below limit line.								
Frequency (MHz)	EIRP (dBm)	Limit (dBm)	Over Limit (dB)	SPA Reading (dBm)	S.G. Power (dBm)	TX Cable loss (dB)	TX Antenna Gain (dBi)	Polarization (H/V)	Result
3819	-37.84	-13	-24.84	-57.38	-44.52	1.70	8.38	H	Pass
5730	-27.11	-13	-14.11	-51.23	-34.14	2.76	9.79	H	Pass
7634	-42.02	-13	-29.02	-70.48	-51.51	2.39	11.88	H	Pass

Band :	CDMA2000 BC1						Temperature :	20~22°C	
Test Mode :	1xEV-DO Rev. 0_RTAP 153.6K (QPSK)						Relative Humidity :	47~48%	
Test Engineer :	Stan Hsieh, Eric Shih, and Derreck Chen						Polarization :	Vertical	
Remark :	Spurious emissions within 30-1000MHz were found more than 20dB below limit line.								
Frequency (MHz)	EIRP (dBm)	Limit (dBm)	Over Limit (dB)	SPA Reading (dBm)	S.G. Power (dBm)	TX Cable loss (dB)	TX Antenna Gain (dBi)	Polarization (H/V)	Result
3819	-40.01	-13	-27.01	-58.69	-46.69	1.70	8.38	V	Pass
5730	-29.25	-13	-16.25	-52.41	-36.28	2.76	9.79	V	Pass
7634	-43.98	-13	-30.98	-72.06	-53.47	2.39	11.88	V	Pass



3.7 Frequency Stability Measurement

3.7.1 Description of Frequency Stability Measurement

The frequency stability shall be measured by variation of ambient temperature and variation of primary supply voltage to ensure that the fundamental emission stays within the authorized frequency block. The frequency stability of the transmitter shall be maintained within $\pm 0.00025\%$ ($\pm 2.5\text{ppm}$) of the center frequency.

3.7.2 Measuring Instruments

The measuring equipment is listed in the section 4 of this test report.

3.7.3 Test Procedures for Temperature Variation

1. The testing follows FCC KDB 971168 v02r02 Section 9.0.
2. The EUT was set up in the thermal chamber and connected with the system simulator.
3. With power OFF, the temperature was decreased to -30°C and the EUT was stabilized before testing. Power was applied and the maximum change in frequency was recorded within one minute.
4. With power OFF, the temperature was raised in 10°C steps up to 50°C . The EUT was stabilized at each step for at least half an hour. Power was applied and the maximum frequency change was recorded within one minute.

3.7.4 Test Procedures for Voltage Variation

1. The testing follows FCC KDB 971168 v02r02 Section 9.0.
2. The EUT was placed in a temperature chamber at $25\pm 5^{\circ}\text{C}$ and connected with the system simulator.
3. The power supply voltage to the EUT was varied from BEP to 115% of the nominal value measured at the input to the EUT.
4. The variation in frequency was measured for the worst case.

3.7.5 Test Setup

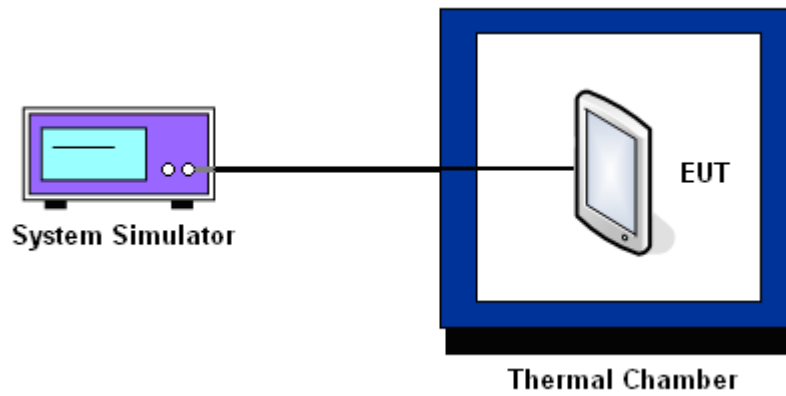



3.7.6 Test Result of Temperature Variation

Band :	CDMA2000 BC0 1xRTT_RC1+SO55	Channel :	384
Limit (ppm) :	2.5	Frequency :	836.52 MHz

Temperature (°C)	Deviation (ppm)	Result
50	0.0167	PASS
40	0.0108	
30	0.0024	
20(Ref.)	0.0000	
10	0.0012	
0	0.0024	
-10	0.0012	
-20	0.0084	
-30	0.0036	

Band :	CDMA2000 BC1 1xEV-DO Rev. 0_RTAP 153.6K	Channel :	600
Limit (ppm) :	within authorized band	Frequency :	1880.0 MHz

Temperature (°C)	Deviation (ppm)	Result
50	0.0011	PASS
40	0.0016	
30	0.0011	
20(Ref.)	0.0000	
10	0.0021	
0	0.0016	
-10	0.0005	
-20	0.0005	
-30	0.0000	

Note: The frequency fundamental emissions stay within the authorized frequency block based on the frequency deviation measured is small.



3.7.7 Test Result of Voltage Variation

Band & Channel	Mode	Voltage (Volt)	Deviation (ppm)	Limit (ppm)	Result
CDMA2000 BC0 CH384	1xRTT RC1+SO55	132	0.0108	2.5	Pass
		120	0.0072		
		BEP	0.0084		
CDMA2000 BC1 CH600	1xEV-DO Rev. 0 RTAP 153.6K	132	0.0005	(Note 3.)	
		120	0.0000		
		BEP	0.0011		

Note:

- 1. Normal Voltage = 132V.
- 2. Battery End Point (BEP) = 120 V.
- 3. The frequency fundamental emissions stay within the authorized frequency block based on the frequency deviation measured is small.



4 List of Measuring Equipment

Instrument	Manufacturer	Model No.	Serial No.	Characteristics	Calibration Date	Test Date	Due Date	Remark
Base Station	Rohde & Schwarz	CMU200	117591	GSM/GPRS/WCD	Oct. 23, 2013	Dec. 15, 2014~ Dec. 18, 2014	Oct. 22, 2015	Radiation (03CH10-HY)
Notch Filter	Wainwright	WRCG1710/ 1755-1690/17	SN2	AWS Band	Oct. 01, 2014	Dec. 15, 2014~ Dec. 18, 2014	Sep. 30, 2015	Radiation (03CH10-HY)
Notch Filter	Wainwright	WRCG824/8 49-40/8SS	SN35	CDMA 850	Oct. 01, 2014	Dec. 15, 2014~ Dec. 18, 2014	Sep. 30, 2015	Radiation (03CH10-HY)
Notch Filter	Wainwright	WRCT1850/1 910-40/8SS	SN21	1900	Oct. 01, 2014	Dec. 15, 2014~ Dec. 18, 2014	Sep. 30, 2015	Radiation (03CH10-HY)
Filter	Wainwright	WLKS1200-8 SS	SN3	1.2G Low Pass	Oct. 01, 2014	Dec. 15, 2014~ Dec. 18, 2014	Sep. 30, 2015	Radiation (03CH10-HY)
Filter	Microwave	H3G018G1	SN477220	3.0G High Pass	Oct. 01, 2014	Dec. 15, 2014~ Dec. 18, 2014	Sep. 30, 2015	Radiation (03CH10-HY)
Amplifier	SONOMA	310N	187311	0.1MHz~1000MHz	Nov. 24, 2014	Dec. 15, 2014~ Dec. 18, 2014	Nov. 23, 2015	Radiation (03CH10-HY)
Bilog Antenna	TESEQ	CBL 6111D	35413	30MHz~1GHz	Oct. 24, 2014	Dec. 15, 2014~ Dec. 18, 2014	Oct. 23, 2015	Radiation (03CH10-HY)
Hygrometer	TECPEL	DTM-303B	TP140320	N/A	Nov. 17, 2014	Dec. 15, 2014~ Dec. 18, 2014	Nov. 16, 2015	Radiation (03CH10-HY)
Preamplifier	Keysight	83017A	MY53270078	1GHz~26.5GHz	Nov. 20, 2014	Dec. 15, 2014~ Dec. 18, 2014	Nov. 19, 2015	Radiation (03CH10-HY)
Spectrum Analyzer	Keysight	N9010A	MY54200485	N/A	Oct. 14, 2014	Dec. 15, 2014~ Dec. 18, 2014	Oct. 13, 2015	Radiation (03CH10-HY)
Double Ridged Guide Horn	SCHWARZBEC K	BBHA 9120 D	9120D-1325	1GHz ~ 18GHz	Oct. 03, 2014	Dec. 15, 2014~ Dec. 18, 2014	Oct. 02, 2015	Radiation (03CH10-HY)
Base Station (Measure)	Anritsu	MT8820C	6201432817	N/A	Oct. 28, 2014	Dec. 15, 2014~ Dec. 18, 2014	Oct. 27, 2015	Radiation (03CH10-HY)
RF Cable	HUBER + SUHNER	SUCOFLEX 104	MY24956/4 MY24952/4M	30MHz~1GHz	Nov. 06, 2014	Dec. 15, 2014~ Dec. 18, 2014	Nov. 05, 2015	Radiation (03CH10-HY)
RF Cable	HUBER + SUHNER	SUCOFLEX 104	MY249564 MY249524MY	1GHz~25GHz	Nov. 06, 2014	Dec. 15, 2014~ Dec. 18, 2014	Nov. 05, 2015	Radiation (03CH10-HY)
Controller	EMEC	EM 1000	N/A	1m-4m	N/A	Dec. 15, 2014~ Dec. 18, 2014	N/A	Radiation (03CH10-HY)
Antenna Mast	EMEC	AM-BS-4500- B	N/A	N/A	N/A	Dec. 15, 2014~ Dec. 18, 2014	N/A	Radiation (03CH10-HY)
Turn Table	EMEC	TT 2200	N/A	0-360 degree	N/A	Dec. 15, 2014~ Dec. 18, 2014	N/A	Radiation (03CH10-HY)
Filter	Wainwright	WHKX1.5/15 G-10SS	SN31	1.5G High Pass	Oct. 01, 2014	Dec. 15, 2014~ Dec. 18, 2014	Sep. 30, 2015	Radiation (03CH10-HY)
Signal Generator	Rohde & Schwarz	SMF100A	101107	100kHz~40GHz	May. 23, 2014	Dec. 15, 2014~ Dec. 18, 2014	May. 22, 2015	Radiation (03CH10-HY)



Instrument	Manufacturer	Model No.	Serial No.	Characteristics	Calibration Date	Test Date	Due Date	Remark
Spectrum Analyzer	Rohde & Schwarz	FSP40	100055	9kHz~40GHz	Jun. 09, 2014	Oct. 06, 2014	Jun. 08, 2015	Conducted (TH02-HY)
Thermal Chamber	Ten Billion	TTH-D3SP	TBN-930701	N/A	Jul. 17, 2014	Oct. 06, 2014	Jul. 16, 2015	Conducted (TH02-HY)
LTE Base Station	Anritsu	MT8820C	6201026480	30MHz~2.7GHz SISO	Jan. 07, 2014	Oct. 06, 2014	Jan. 06, 2015	Conducted (TH02-HY)



5 Uncertainty of Evaluation

Uncertainty of Radiated Emission Measurement (30 MHz ~ 1000 MHz)

Measuring Uncertainty for a Level of Confidence of 95% ($U = 2Uc(y)$)	4.90
---	------

Uncertainty of Radiated Emission Measurement (1 GHz ~ 40 GHz)

Measuring Uncertainty for a Level of Confidence of 95% ($U = 2Uc(y)$)	5.50
---	------