



FCC RF Test Report

APPLICANT : DT Research Inc.
EQUIPMENT : Mobile Tablet
BRAND NAME : DT Research Inc.
MODEL NAME : DT398
FCC ID : YE3800B
STANDARD : FCC 47 CFR Part 2, 22(H), 24(E)
CLASSIFICATION : PCS Licensed Transmitter (PCB)

The product was received on Feb. 20, 2013 and completely tested on Mar. 14, 2013. We, SPORTON INTERNATIONAL INC., would like to declare that the tested sample has been evaluated in accordance with the procedures given in ANSI / TIA / EIA-603-C-2004 and shown compliance with the applicable technical standards.

The test results in this report apply exclusively to the tested model / sample. Without written approval of SPORTON INTERNATIONAL INC., the test report shall not be reproduced except in full.

Reviewed by: Joseph Lin / Supervisor

Approved by: Jones Tsai / Manager



SPORTON INTERNATIONAL INC.

No. 52, Hwa Ya 1st Rd., Hwa Ya Technology Park, Kwei-Shan Hsiang, Tao Yuan Hsien, Taiwan, R.O.C.



TABLE OF CONTENTS

REVISION HISTORY..... 3

SUMMARY OF TEST RESULT 4

1 GENERAL DESCRIPTION 5

 1.1 Applicant..... 5

 1.2 Manufacturer 5

 1.3 Feature of Equipment Under Test..... 5

 1.4 Product Specification of Equipment Under Test 5

 1.5 Maximum ERP/EIRP Power, Frequency Tolerance, and Emission Designator 6

 1.6 Testing Site..... 6

 1.7 Applied Standards 7

2 TEST CONFIGURATION OF EQUIPMENT UNDER TEST 8

 2.1 Test Mode..... 8

 2.2 Connection Diagram of Test System 9

 2.3 Support Unit used in test configuration and system 9

 2.4 Measurement Results Explanation Example 10

3 TEST RESULT 11

 3.1 Conducted Output Power and ERP/EIRP Measurement 11

 3.2 Peak-to-Average Ratio 14

 3.3 99% Occupied Bandwidth and 26dB Bandwidth Measurement..... 20

 3.4 Band Edge Measurement..... 28

 3.5 Conducted Spurious Emission Measurement 34

 3.6 Field Strength of Spurious Radiation Measurement 40

 3.7 Frequency Stability Measurement..... 47

4 LIST OF MEASURING EQUIPMENT 51

5 UNCERTAINTY OF EVALUATION 52

APPENDIX A. PHOTOGRAPHS OF EUT

APPENDIX B. SETUP PHOTOGRAPHS



REVISION HISTORY

REPORT NO.	VERSION	DESCRIPTION	ISSUED DATE
FG322149	Rev. 01	Initial issue of report	Mar. 29, 2013



SUMMARY OF TEST RESULT

Report Section	FCC Rule	IC Rule	Description	Limit	Result	Remark
3.1	§2.1046	RSS-132 (5.4) RSS-133 (6.4)	Conducted Output Power	N/A	PASS	-
3.1	§22.913(a)(2)	RSS-132(5.4) SRSP-503(5.1.3)	Effective Radiated Power	< 7 Watts	PASS	-
3.1	§24.232(c)	RSS-133 (6.4) SRSP-510(5.1.2)	Equivalent Isotropic Radiated Power	< 2 Watts	PASS	-
3.2	§24.232(d)	RSS-132 (5.4) RSS-133(6.4)	Peak-to-Average Ratio	< 13 dB	PASS	-
3.3	§2.1049 §22.917(a) §24.238(a)	RSS-GEN(4.6.1) RSS-133(2.3)	Occupied Bandwidth	N/A	PASS	-
3.4	§2.1051 §22.917(a) §24.238(a)	RSS-132 (5.5) RSS-133 (6.5)	Band Edge Measurement	< 43+10log ₁₀ (P[Watts])	PASS	-
3.5	§2.1051 §22.917(a) §24.238(a)	RSS-132 (5.5) RSS-133 (6.5)	Conducted Spurious Emission	< 43+10log ₁₀ (P[Watts])	PASS	-
3.6	§2.1053 §22.917(a) §24.238(a)	RSS-132 (5.5) RSS-133 (6.5)	Field Strength of Spurious Radiation	< 43+10log ₁₀ (P[Watts])	PASS	Under limit 19.88 dB at 5640.000 MHz
3.7	§2.1055 §22.355 §24.235	RSS-132(5.3) RSS-133(6.3)	Frequency Stability for Temperature & Voltage	< 2.5 ppm	PASS	-

1 General Description

1.1 Applicant

DT Research Inc.
6F., NO. 1, NingPo E. St., Taipei, 100 Taiwan, R.O.C.

1.2 Manufacturer

DT Research Inc.
6F., NO. 1, NingPo E. St., Taipei, 100 Taiwan, R.O.C.

1.3 Feature of Equipment Under Test

Product Feature	
Equipment	Mobile Tablet
Brand Name	DT Research Inc.
Model Name	DT398
FCC ID	YE3800B
EUT supports Radios application	CDMA/EV-DO/ WLAN 11abgn / Bluetooth 2.1/3.0/4.0
EUT Stage	Production Unit

Remark: The above EUT's information was declared by manufacturer. Please refer to the specifications or user's manual for more detailed description.

1.4 Product Specification of Equipment Under Test

Product Specification subjective to this standard	
Tx Frequency	CDMA2000 BC0: 824.70 MHz ~ 848.31 MHz CDMA2000 BC1: 1851.25 MHz ~ 1908.75 MHz
Rx Frequency	CDMA2000 BC0: 869.70 MHz ~ 893.31 MHz CDMA2000 BC1: 1931.25 MHz ~ 1988.75 MHz
Maximum Output Power to Antenna	CDMA2000 BC0 : 23.64 dBm CDMA2000 BC1 : 23.95 dBm
Antenna Type	PIFA Antenna
Antenna Gain	CDMA2000 BC0 : 2.70 dBi CDMA2000 BC1 : 2.51 dBi
Type of Modulation	CDMA2000 : QPSK CDMA2000 1xEV-DO : QPSK/8PSK

1.5 Maximum ERP/EIRP Power, Frequency Tolerance, and Emission Designator

FCC Rule	System	Type of Modulation	Maximum ERP/EIRP (W)	Frequency Tolerance (% , Hz, ppm)	Emission Designator
Part 22	CDMA2000 BC0 1xEV-DO Rev. 0	QPSK	0.2624	0.03 ppm	1M28F9W
Part 24	CDMA2000 BC1 1xEV-DO Rev. 0	QPSK	0.4426	0.01 ppm	1M28F9W

1.6 Testing Site

Test Site	SPORTON INTERNATIONAL INC.		
Test Site Location	No. 52, Hwa Ya 1 st Rd., Hwa Ya Technology Park, Kwei-Shan Hsiang, Tao Yuan Hsien, Taiwan, R.O.C. TEL: +886-3-327-3456 FAX: +886-3-328-4978		
Test Site No.	Sporton Site No.		FCC/IC Registration No.
	TH02-HY	03CH05-HY	722060/4086B-1



1.7 Applied Standards

According to the specifications of the manufacturer, the EUT must comply with the requirements of the following standards:

- ♦ FCC 47 CFR Part 2, 22(H), 24(E)
- ♦ ANSI / TIA / EIA-603-C-2004
- ♦ FCC KDB 412172 D01 Determining ERP and ERIP v01

Remark:

1. All test items were verified and recorded according to the standards and without any deviation during the test.
2. This EUT has also been tested and complied with the requirements of FCC Part 15, Subpart B, recorded in a separate test report.

2 Test Configuration of Equipment Under Test

2.1 Test Mode

During all testing, EUT is in link mode with base station emulator at maximum power level. The spurious emission measurements were carried out in semi-anechoic chamber with 3-meter test range, and EUT is rotated on three test planes to find out the worst emission.

Frequency range investigated for radiated emission is as follows:

1. 30 MHz to 9000 MHz for CDMA2000 BC0.
2. 30 MHz to 19000 MHz for CDMA2000 BC1.

Test Modes		
Band	Radiated TCs	Conducted TCs
CDMA2000 BC0	■ 1xEV-DO Rev. 0 Link Mode	■ 1xEV-DO Rev. 0 Link Mode
CDMA2000 BC1	■ 1xEV-DO Rev. 0 Link Mode	■ 1xEV-DO Rev. 0 Link Mode

Note:

1. The maximum RF output power levels are 1xEV-DO Rev. 0 RTAP 153.6K mode for CDMA2000 BC0 on QPSK Link and 1xEV-DO Rev. 0 RTAP 153.6K mode for CDMA2000 BC1 on QPSK Link; only these modes were used for all tests.
2. Because there are individual antennas for each WWAN, WLAN, and Bluetooth, the co-location test modes are not required.

The conducted power table is as follows:

Band	Conducted Power (*Unit: dBm)					
	CDMA2000 BC0			CDMA2000 BC1		
Channel	1013	384	777	25	600	1175
Frequency	824.7	836.52	848.31	1851.25	1880	1908.75
1xRTT RC1+SO55	23.43	23.49	23.41	23.83	23.76	23.54
1xRTT RC3+SO55	23.40	23.50	23.32	23.74	23.73	23.44
1xRTT RC3+SO32 (+ F-SCH)	23.42	23.52	23.33	23.81	23.74	23.43
1xRTT RC3+SO32(+SCH)	23.45	23.51	23.29	23.79	23.72	23.46
1xEV-DO RTAP 153.6K	23.49	23.64	23.47	23.95	23.90	23.63
1xEV-DO RETAP 4096K	23.55	23.59	23.50	23.93	23.88	23.58

2.2 Connection Diagram of Test System

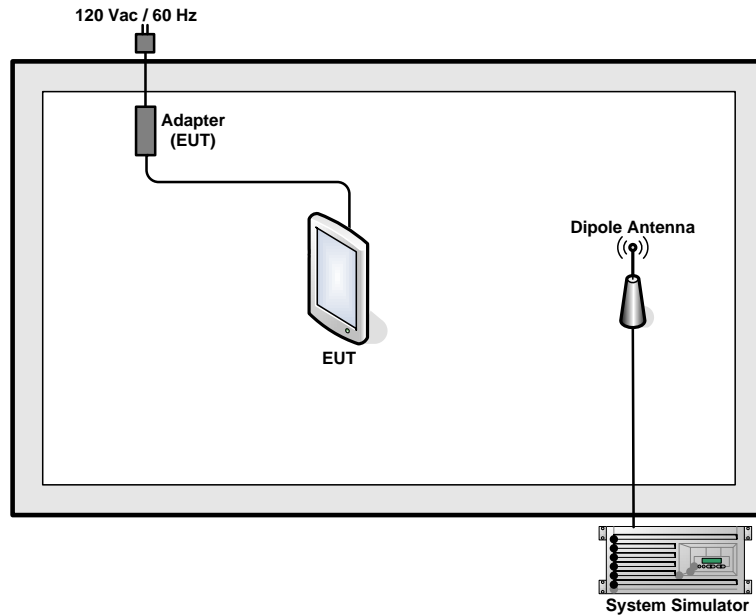

2.3 Support Unit used in test configuration and system

Item	Equipment	Trade Name	Model No.	FCC ID	Data Cable	Power Cord
1.	System Simulator	Agilent	E5515C	N/A	N/A	Unshielded, 1.8 m



2.4 Measurement Results Explanation Example

For all conducted test items:

The offset level is set in the spectrum analyzer to compensate the RF cable loss and attenuator factor between EUT conducted output port and spectrum analyzer. With the offset compensation, the spectrum analyzer reading level is exactly the EUT RF output level.

The spectrum analyzer offset is derived from RF cable loss and attenuator factor.

Offset = RF cable loss + attenuator factor.

Following shows an offset computation example with cable loss 4.2 dB and 10dB attenuator.

Example :

$$\begin{aligned} \text{Offset(dB)} &= \text{RF cable loss(dB)} + \text{attenuator factor(dB)}. \\ &= 4.2 + 10 = 14.2 \text{ (dB)} \end{aligned}$$

3 Test Result

3.1 Conducted Output Power and ERP/EIRP Measurement

3.1.1 Description of the Conducted Output Power and ERP/EIRP Measurement

A base station simulator was used to establish communication with the EUT. Its parameters were set to transmit the maximum power on the EUT. The measured power in the radio frequency on the transmitter output terminals shall be reported.

The ERP of mobile transmitters must not exceed 7 Watts and the EIRP of mobile transmitters are limited to 2 Watts. According to KDB 412172 D01 Power Approach,

$EIRP = P_T + G_T - L_C$, $ERP = EIRP - 2.15$, where

P_T = transmitter output power in dBm

G_T = gain of the transmitting antenna in dBi

L_C = signal attenuation in the connecting cable between the transmitter and antenna in dB

3.1.2 Measuring Instruments

See list of measuring instruments of this test report.

3.1.3 Test Procedures

1. The transmitter output port was connected to base station.
2. The RF output of EUT was connected to the spectrum analyzer by RF cable and attenuator. The path loss was compensated to the results for each measurement.
3. Set EUT at maximum power through base station.
4. Select lowest, middle, and highest channels for each band and different modulation.
5. Measure the maximum burst average power for GSM and maximum average power for other modulation signal.

3.1.4 Test Setup

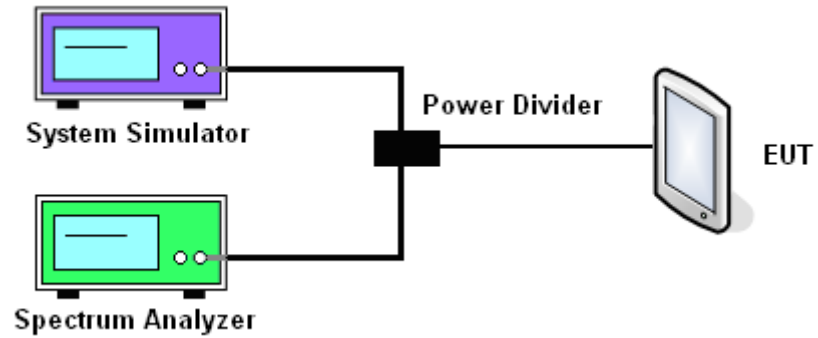

3.1.5 Test Result of Conducted Output Power

Cellular Band ($G_T - L_C = 2.7\text{dB}$)			
Modes	CDMA 2000 1xEV-DO Rev. 0		
Test Status	RTAP 153.6K		
Channel	1013 (Low)	384 (Mid)	777 (High)
Frequency (MHz)	824.70	836.52	848.31
Conducted Power (dBm)	23.49	23.64	23.47
Conducted Power (Watts)	0.22	0.23	0.22
ERP(dBm)	24.04	24.19	24.02
ERP(Watts)	0.2535	0.2624	0.2523

PCS Band ($G_T - L_C = 2.51\text{dB}$)			
Modes	CDMA 2000 1xEV-DO Rev. 0		
Test Status	RTAP 153.6K		
Channel	25 (Low)	600 (Mid)	1175 (High)
Frequency (MHz)	1851.25	1880.00	1908.75
Conducted Power (dBm)	23.95	23.9	23.63
Conducted Power (Watts)	0.25	0.25	0.23
EIRP(dBm)	26.46	26.41	26.14
EIRP(Watts)	0.4426	0.4375	0.4111

Note:

$EIRP = P_T + G_T - L_C$, $ERP = EIRP - 2.15$, where

P_T = transmitter output power in dBm

G_T = gain of the transmitting antenna in dBi

L_C = signal attenuation in the connecting cable between the transmitter and antenna in dB

3.2 Peak-to-Average Ratio

3.2.1 Description of the PAR Measurement

The peak-to-average ratio (PAR) of the transmission may not exceed 13 dB.

3.2.2 Measuring Instruments

See list of measuring instruments of this test report.

3.2.3 Test Procedures

1. The EUT was connected to Spectrum Analyzer and System Simulator via power divider.
2. For GSM/EGPRS operating modes:
 - a. Set EUT in maximum power output.
 - b. Set the RBW = 1MHz, VBW = 3MHz, Peak detector in spectrum analyzer for first trace.
 - c. Set the RBW = 1MHz, VBW = 3MHz, RMS detector in spectrum analyzer for second trace.
 - d. The wanted burst signal is triggered by spectrum analyzer, and measured respectively the peak level and Mean level without burst-off time, after system simulator synchronized with the spectrum analyzer.
3. For UMTS operating modes:
 - a. Set the CCDF (Complementary Cumulative Distribution Function) option in spectrum analyzer.
 - b. The highest RF powers were measured and recorded the maximum PAPR level associated with a probability of 0.1 %.
4. Record the deviation as Peak to Average Ratio.

3.2.4 Test Setup

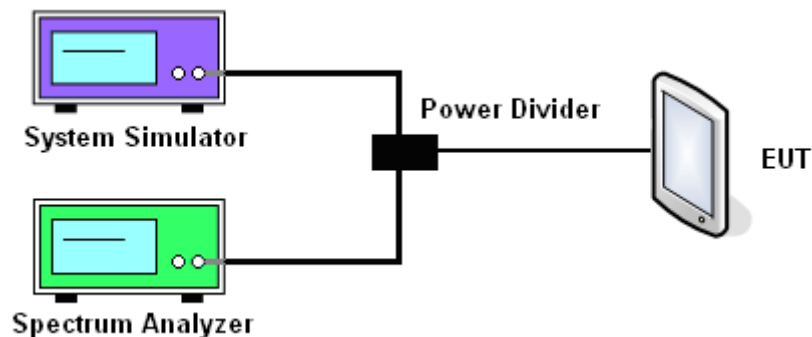



3.2.5 Test Result of Peak-to-Average Ratio

CDMA2000 BC0			
Modes	CDMA 2000 1xEV-DO Rev. 0		
Test Status	RTAP 153.6K		
Channel	1013 (Low)	384 (Mid)	777 (High)
Frequency (MHz)	824.70	836.52	848.31
Peak-to-Average Ratio (dB)	4.36	4.08	3.96

CDMA2000 BC1			
Modes	CDMA 2000 1xEV-DO Rev. 0		
Test Status	RTAP 153.6K		
Channel	25 (Low)	600 (Mid)	1175 (High)
Frequency (MHz)	1851.25	1880.00	1908.75
Peak-to-Average Ratio (dB)	3.80	4.08	4.00



3.2.6 Test Result (Plots) of Peak-to-Average Ratio

Band :	CDMA2000 BC0	Test Mode :	1xEV-DO RTAP 153.6K Link (QPSK)
--------	--------------	-------------	---------------------------------

Peak-to-Average Ratio on Channel 1013 (824.70 MHz)

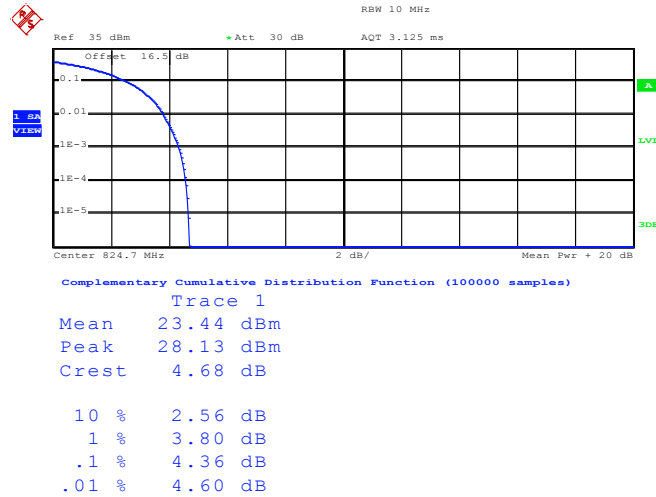

Date: 9.MAR.2013 00:46:54

Peak-to-Average Ratio on Channel 384 (836.52 MHz)

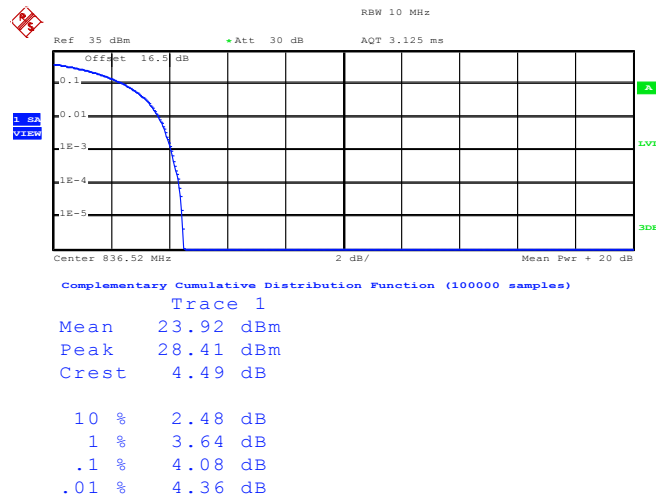

Date: 9.MAR.2013 00:47:38



Peak-to-Average Ratio on Channel 777 (848.31 MHz)

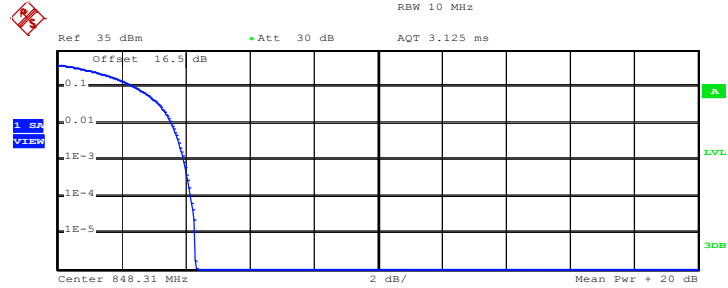

Complementary Cumulative Distribution Function (100000 samples)

Trace 1

Mean	23.53 dBm
Peak	27.84 dBm
Crest	4.31 dB
10 %	2.44 dB
1 %	3.56 dB
.1 %	3.96 dB
.01 %	4.16 dB

Date: 9.MAR.2013 00:48:38



Band :	CDMA2000 BC1	Test Mode :	1xEV-DO RTAP 153.6K Link (QPSK)
---------------	--------------	--------------------	---------------------------------

Peak-to-Average Ratio on Channel 25 (1851.25 MHz)

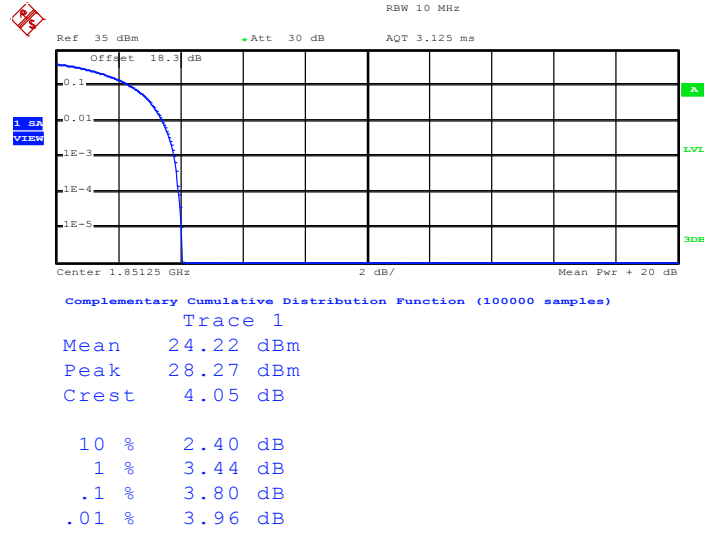

Date: 9.MAR.2013 01:30:11

Peak-to-Average Ratio on Channel 600 (1880 MHz)

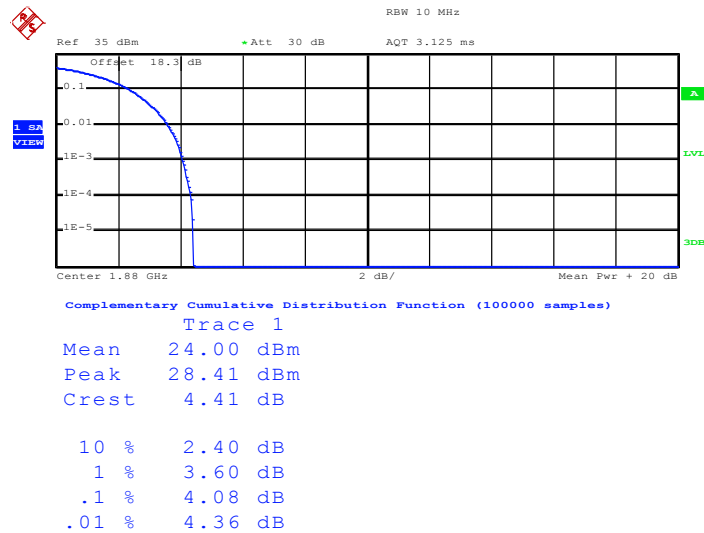

Date: 9.MAR.2013 01:30:52



Peak-to-Average Ratio on Channel 1175 (1908.75 MHz)

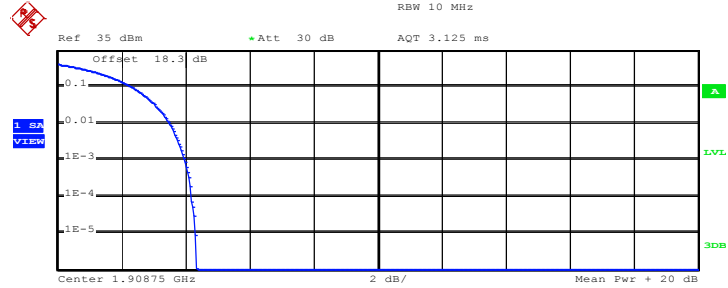

Complementary Cumulative Distribution Function (100000 samples)

Trace 1

Mean	23.66 dBm
Peak	27.99 dBm
Crest	4.33 dB
10 %	2.36 dB
1 %	3.52 dB
.1 %	4.00 dB
.01 %	4.20 dB

Date: 9.MAR.2013 01:33:19

3.3 99% Occupied Bandwidth and 26dB Bandwidth Measurement

3.3.1 Description of 99% Occupied Bandwidth and 26dB Bandwidth Measurement

The 99% occupied bandwidth is the width of a frequency band such that, below the lower and above the upper frequency limits, the mean powers emitted are each equal to a specified percentage 0.5% of the total mean transmitted power.

The emission bandwidth is defined as the width of the signal between two points, located at the 2 sides of the carrier frequency, outside of which all emissions are attenuated at least 26 dB below the transmitter power.

3.3.2 Measuring Instruments

See list of measuring instruments of this test report.

3.3.3 Test Procedures

1. The EUT was connected to Spectrum Analyzer and Base Station via power divider.
2. The RF output of EUT was connected to the spectrum analyzer by RF cable and attenuator. The path loss was compensated to the results for each measurement.
3. The 99% occupied bandwidth and 26 dB bandwidth of the middle channel for the highest RF powers were measured.

3.3.4 Test Setup

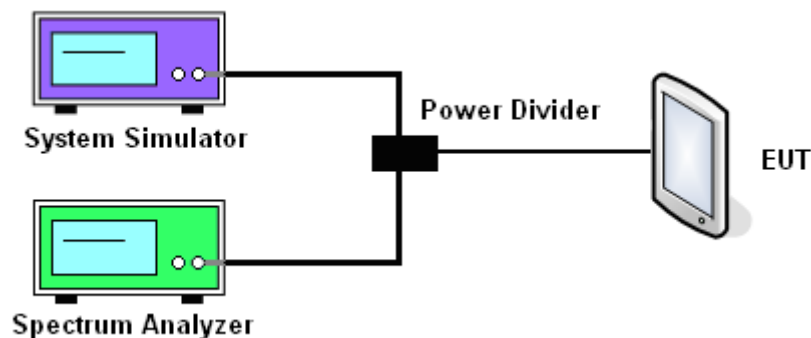



3.3.5 Test Result of Occupied Bandwidth and 26dB Bandwidth

CDMA2000 BC0			
Test Mode	CDMA 2000 1xEV-DO Rev. 0		
Test Status	RTAP 153.6K		
Channel	1013 (Low)	384 (Mid)	777 (High)
Frequency (MHz)	824.70	836.52	848.31
99% OBW (MHz)	1.276	1.276	1.276
26dB BW (MHz)	1.424	1.432	1.436

CDMA2000 BC1			
Test Mode	CDMA 2000 1xEV-DO Rev. 0		
Test Status	RTAP 153.6K		
Channel	25 (Low)	600 (Mid)	1175 (High)
Frequency (MHz)	1851.25	1880.00	1908.75
99% OBW (MHz)	1.280	1.280	1.280
26dB BW (MHz)	1.436	1.440	1.444



3.3.6 Test Result (Plots) of Occupied Bandwidth and 26dB Bandwidth

Band :	CDMA2000 BC0	Test Mode :	1xEV-DO Rev. 0_RTAP 153.6K (QPSK)
--------	--------------	-------------	-----------------------------------

99% Occupied Bandwidth Plot on Channel 1013 (824.7 MHz)

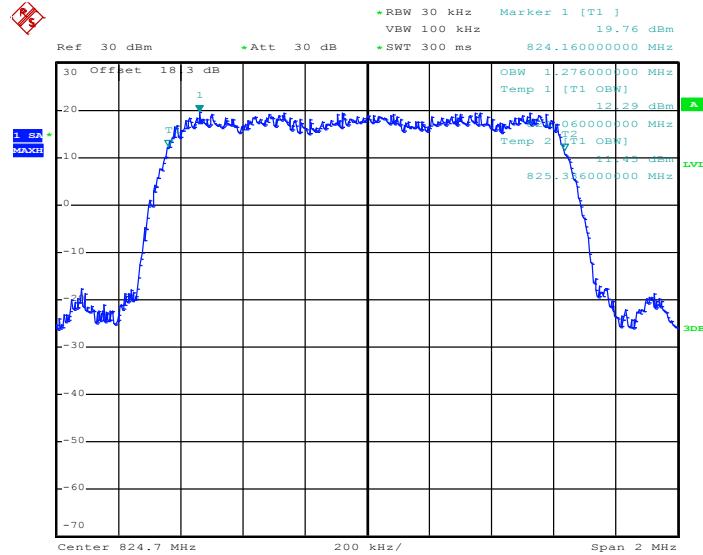

Date: 9.MAR.2013 00:44:56

26dB Bandwidth Plot on Channel 1013 (824.7 MHz)

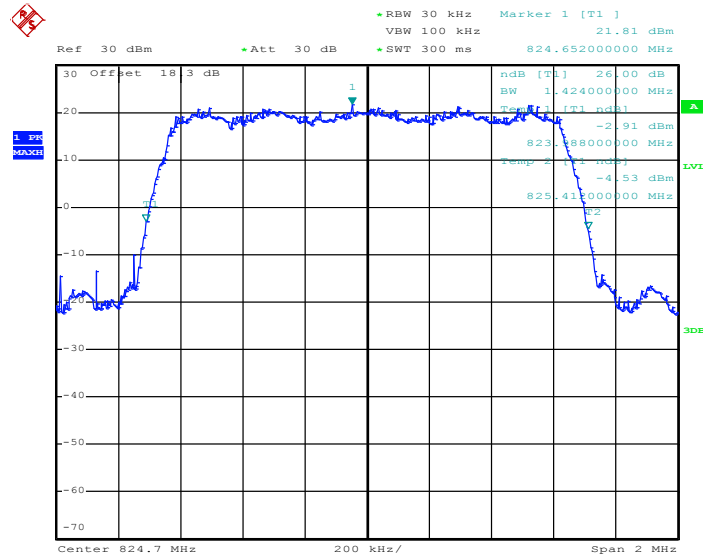

Date: 9.MAR.2013 00:39:21



99% Occupied Bandwidth Plot on Channel 384 (836.52 MHz)

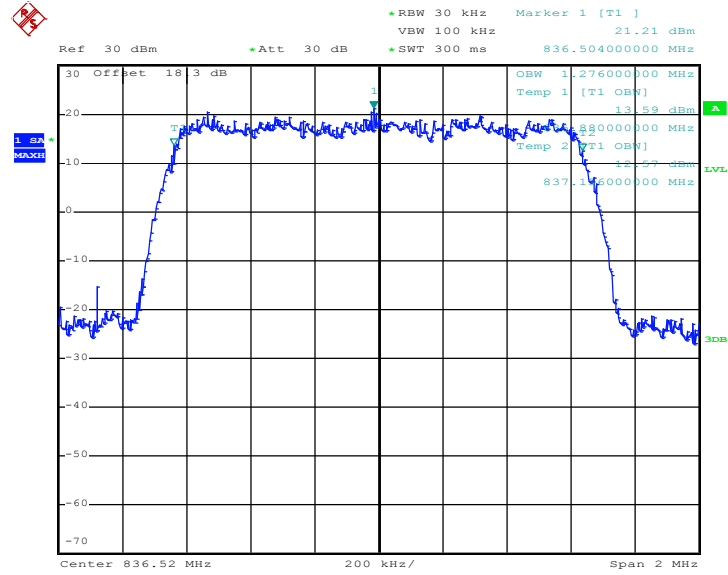

Date: 9.MAR.2013 00:43:20

26dB Bandwidth Plot on Channel 384 (836.52 MHz)

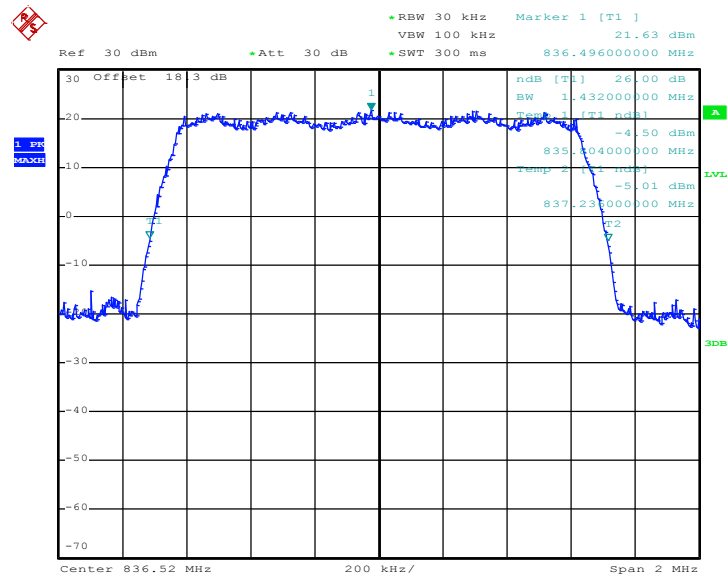

Date: 9.MAR.2013 00:38:44



99% Occupied Bandwidth Plot on Channel 777 (848.31 MHz)

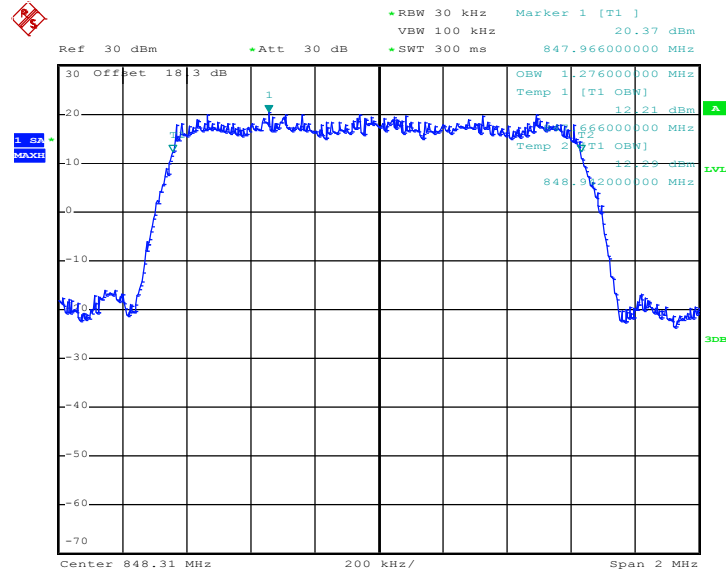

Date: 9.MAR.2013 00:42:02

26dB Bandwidth Plot on Channel 777 (848.31 MHz)

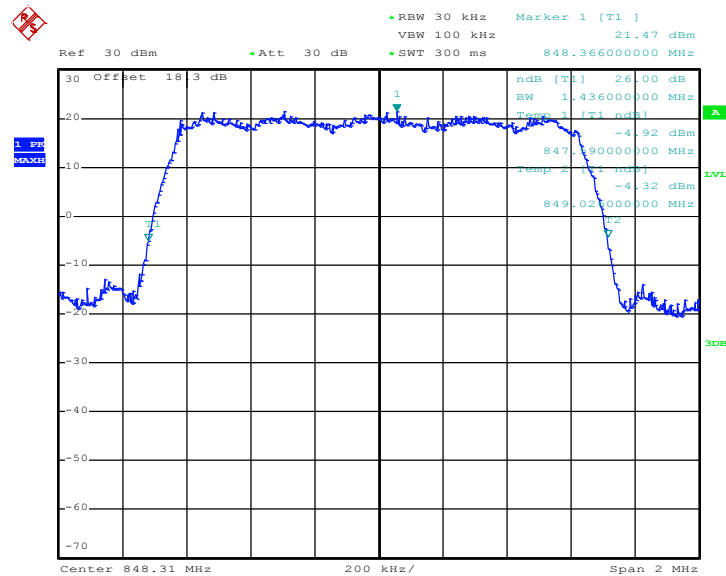

Date: 9.MAR.2013 00:40:03



Band :	CDMA2000 BC1	Test Mode :	1xEV-DO Rev. 0_RTAP 153.6K (QPSK)
--------	--------------	-------------	-----------------------------------

99% Occupied Bandwidth Plot on Channel 25 (1851.25 MHz)

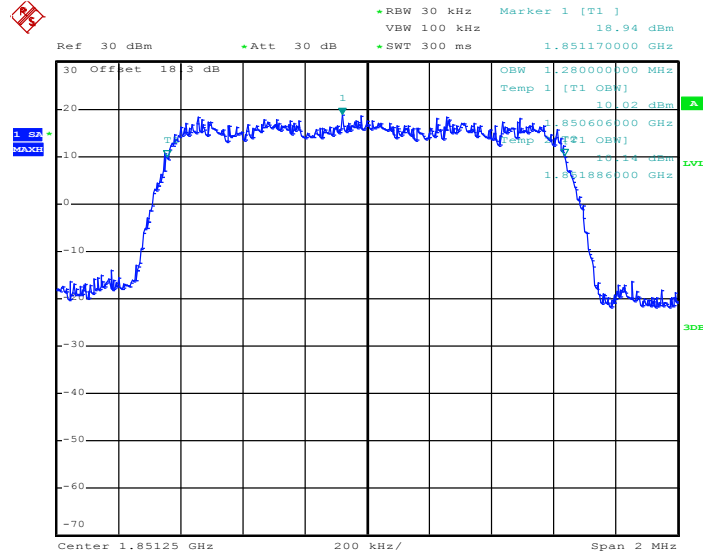

Date: 9.MAR.2013 01:57:41

26dB Bandwidth Plot on Channel 25 (1851.25 MHz)

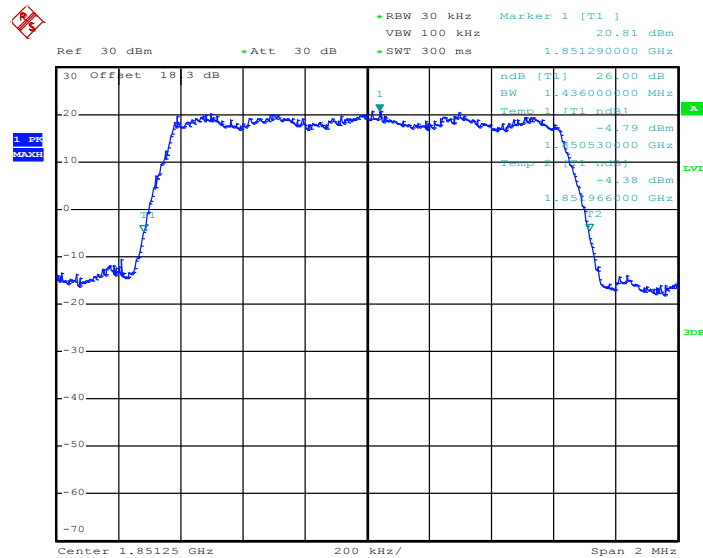

Date: 9.MAR.2013 01:47:50



99% Occupied Bandwidth Plot on Channel 600 (1880.0 MHz)

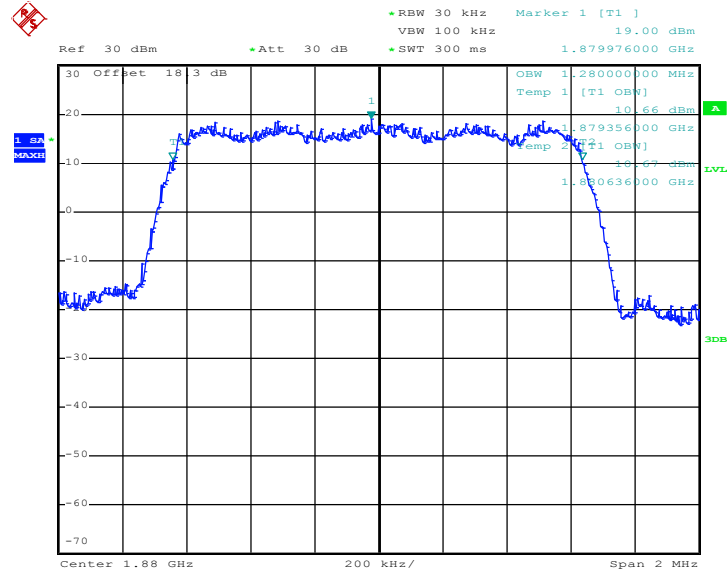

Date: 9.MAR.2013 01:55:20

26dB Bandwidth Plot on Channel 600 (1880.0 MHz)

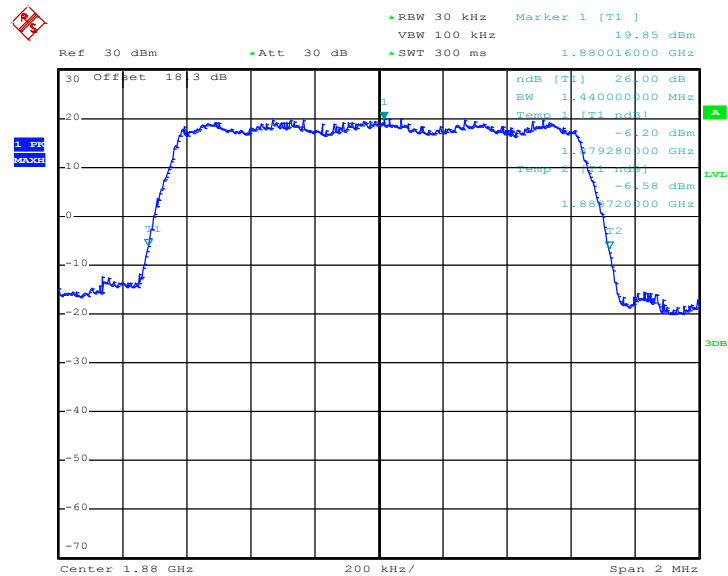

Date: 9.MAR.2013 01:49:11



99% Occupied Bandwidth Plot on Channel 1175 (1908.75 MHz)

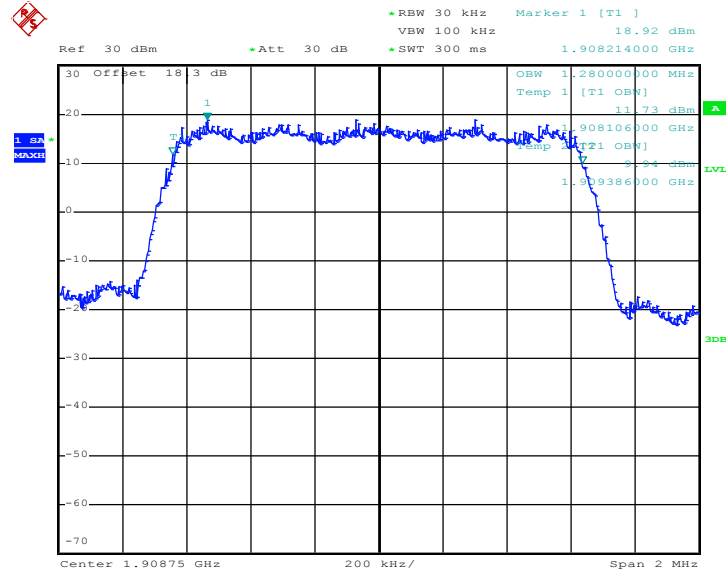

Date: 9.MAR.2013 01:52:51

26dB Bandwidth Plot on Channel 1175 (1908.75 MHz)

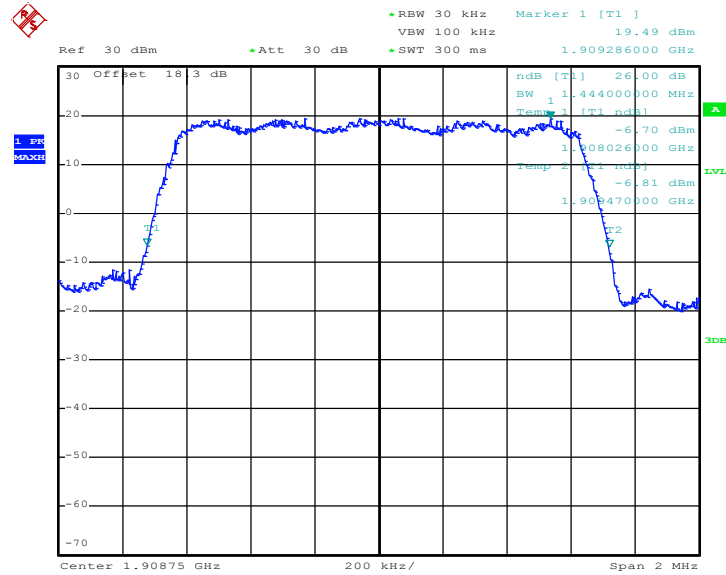

Date: 9.MAR.2013 01:50:21

3.4 Band Edge Measurement

3.4.1 Description of Band Edge Measurement

The power of any emission outside of the authorized operating frequency ranges must be lower than the transmitter power (P) by a factor of at least $43 + 10 \log (P)$ dB.

3.4.2 Measuring Instruments

See list of measuring instruments of this test report.

3.4.3 Test Procedures

1. The EUT was connected to Spectrum Analyzer and Base Station via power divider.
2. The RF output of EUT was connected to the spectrum analyzer by RF cable and attenuator. The path loss was compensated to the results for each measurement.
3. The band edges of low and high channels for the highest RF powers were measured. Setting RBW as roughly $BW/100$.
4. The RBW was replaced by 10 kHz, slightly smaller than the value in (3), due to the spectrum analyzer limitation to set the exact value. A worst case correction factor of $10 \cdot \log (1\% \text{ emission-BW/measurement RBW})$ was compensated.
5. The RF fundamental frequency should be excluded against the limit line in the operating frequency band.
6. The limit line is derived from $43 + 10 \log(P)$ dB below the transmitter power P(Watts)
 $= P(W) - [43 + 10 \log(P)] \text{ (dB)}$
 $= [30 + 10 \log(P)] \text{ (dBm)} - [43 + 10 \log(P)] \text{ (dB)}$
 $= -13 \text{ dBm.}$

3.4.4 Test Setup

<Conducted Band Edge >

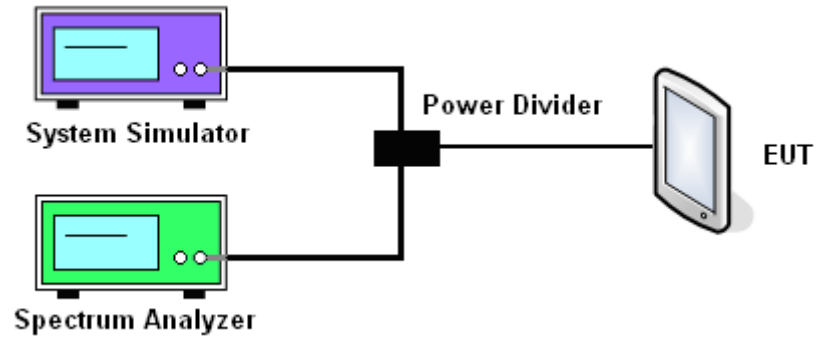



3.4.5 Test Result (Plots) of Conducted Band Edge

Band :	CDMA2000 BC0	Test Mode :	1xEV-DO Rev. 0_RTAP 153.6K (QPSK)
Correction Factor :	1.57dB	Maximum 26dB Bandwidth :	1.436MHz
Band Edge :	-17.96dBm	Measurement Value :	-19.53dBm

Lower Band Edge Plot on Channel 1013 (824.7 MHz)

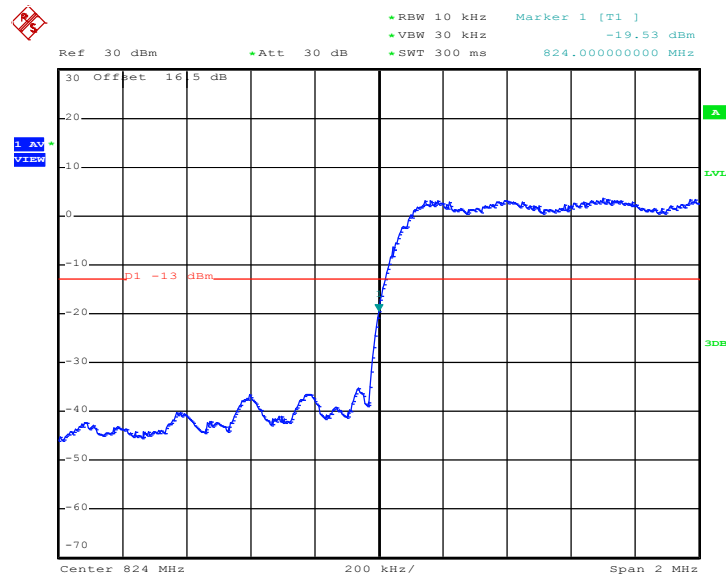

Date: 9.MAR.2013 00:52:00

1. Correction Factor(dB)= 10log(1% Emission BW/RBW)
2. Band Edge= Measurement Value + Correction Factor(dB)



Band :	CDMA2000 BC0	Test Mode :	1xEV-DO Rev. 0_RTAP 153.6K (QPSK)
Correction Factor :	1.57dB	Maximum 26dB Bandwidth:	1.436MHz
Band Edge :	-14.58dBm	Measurement Value :	-16.15dBm

Higher Band Edge Plot on Channel 777 (848.31 MHz)

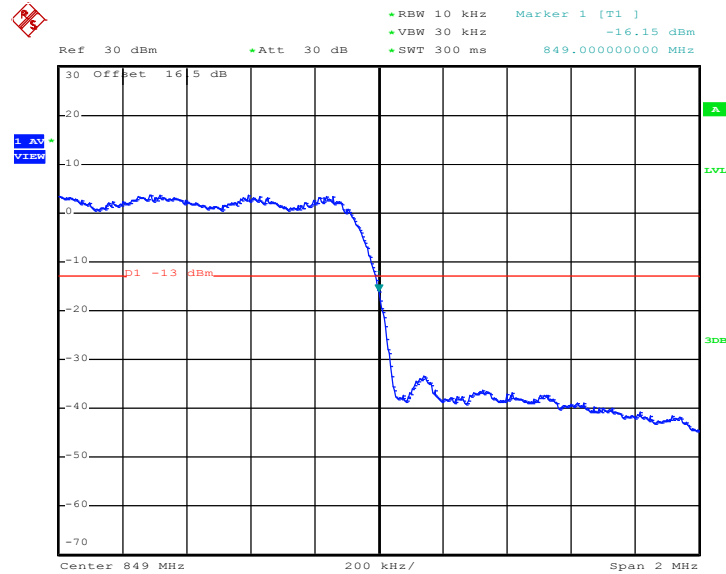

Date: 9.MAR.2013 00:51:00

1. Correction Factor(dB)= $10\log(1\% \text{ Emission BW/RBW})$
2. Band Edge= Measurement Value + Correction Factor(dB)



Band :	CDMA2000 BC1	Test Mode :	1xEV-DO Rev. 0_RTAP 153.6K (QPSK)
Correction Factor :	1.60dB	Maximum 26dB Bandwidth:	1.444MHz
Band Edge :	-32.33dBm	Measurement Value :	-33.93dBm

Lower Band Edge Plot on Channel 25 (1851.25 MHz)

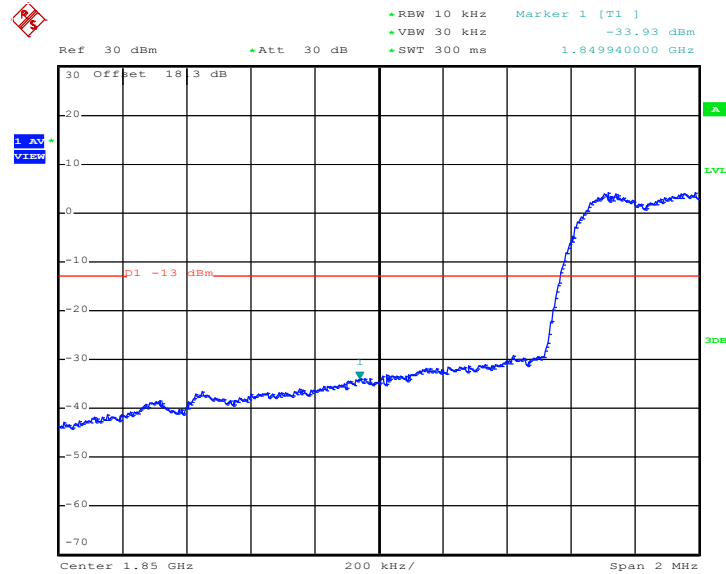

Date: 9.MAR.2013 01:15:02

1. Correction Factor(dB)= 10log(1% Emission BW/RBW)
2. Band Edge= Measurement Value + Correction Factor(dB)



Band :	CDMA2000 BC1	Test Mode :	1xEV-DO Rev. 0_RTAP 153.6K (QPSK)
Correction Factor :	1.60dB	Maximum 26dB Bandwidth:	1.444MHz
Band Edge :	-36.19dBm	Measurement Value :	-37.79dBm

Higher Band Edge Plot on Channel 1175 (1908.75 MHz)

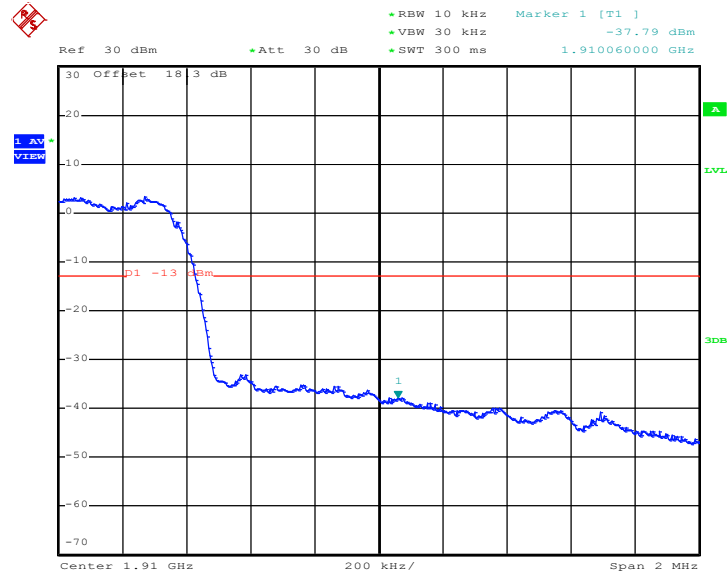

Date: 9.MAR.2013 01:17:15

1. Correction Factor(dB)= $10\log(1\% \text{ Emission BW/RBW})$
2. Band Edge= Measurement Value + Correction Factor(dB)

3.5 Conducted Spurious Emission Measurement

3.5.1 Description of Conducted Emission Measurement

The power of any emission outside of the authorized operating frequency ranges must be lower than the transmitter power (P) by a factor of at least $43 + 10 \log (P)$ dB.

It is measured by means of a calibrated spectrum analyzer and scanned from 30 MHz up to a frequency including its 10th harmonic.

3.5.2 Measuring Instruments

See list of measuring instruments of this test report.

3.5.3 Test Procedures

1. The EUT was connected to spectrum analyzer and base station via power divider.
2. The RF output of EUT was connected to the spectrum analyzer by RF cable and attenuator. The path loss was compensated to the results for each measurement.
3. The middle channel for the highest RF power within the transmitting frequency was measured.
4. The conducted spurious emission for the whole frequency range was taken.
5. The RF fundamental frequency should be excluded against the limit line in the operating frequency band.
6. The limit line is derived from $43 + 10\log(P)$ dB below the transmitter power P(Watts)

$$= P(W) - [43 + 10\log(P)] \text{ (dB)}$$

$$= [30 + 10\log(P)] \text{ (dBm)} - [43 + 10\log(P)] \text{ (dB)}$$

$$= -13\text{dBm}.$$

3.5.4 Test Setup

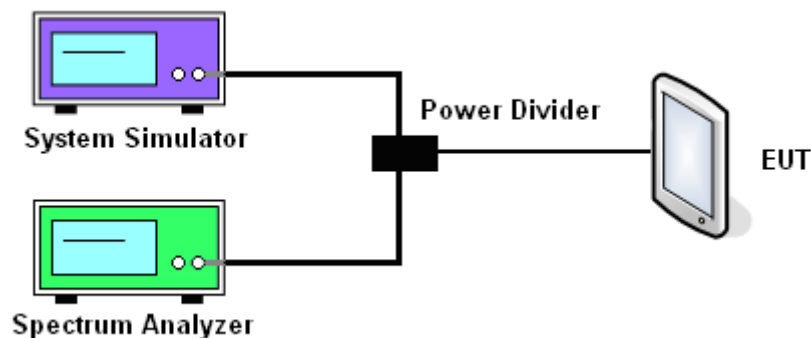



3.5.5 Test Result (Plots) of Conducted Spurious Emission

Band :	CDMA2000 BC0	Channel	384
Test Mode :	1xEV-DO Rev. 0_RTAP 153.6K (QPSK)	Frequency :	836.52 MHz

Conducted Spurious Emission Plot between 30MHz ~ 1GHz

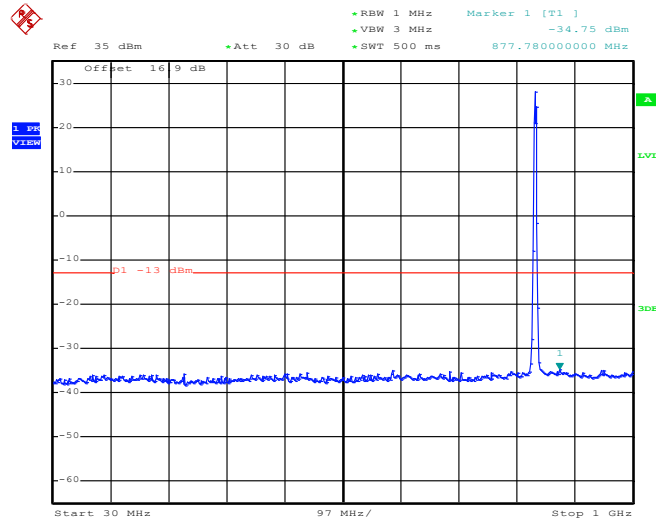

Date: 8.MAR.2013 23:59:28

Conducted Spurious Emission Plot between 1GHz ~ 3GHz

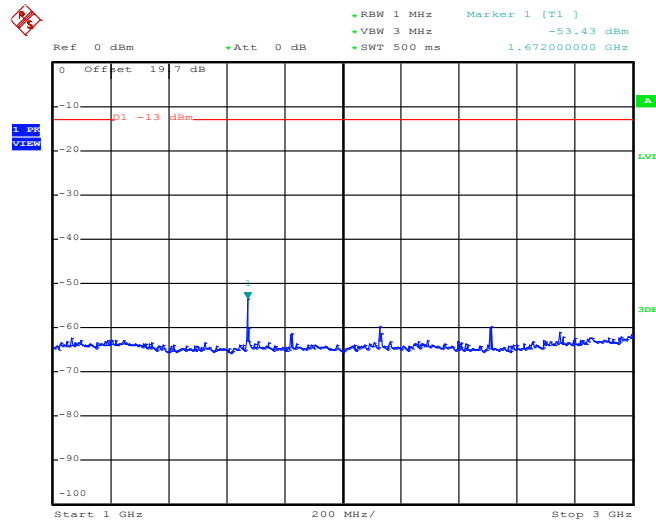

Date: 8.MAR.2013 23:59:45



Conducted Spurious Emission Plot between 3GHz ~ 7GHz

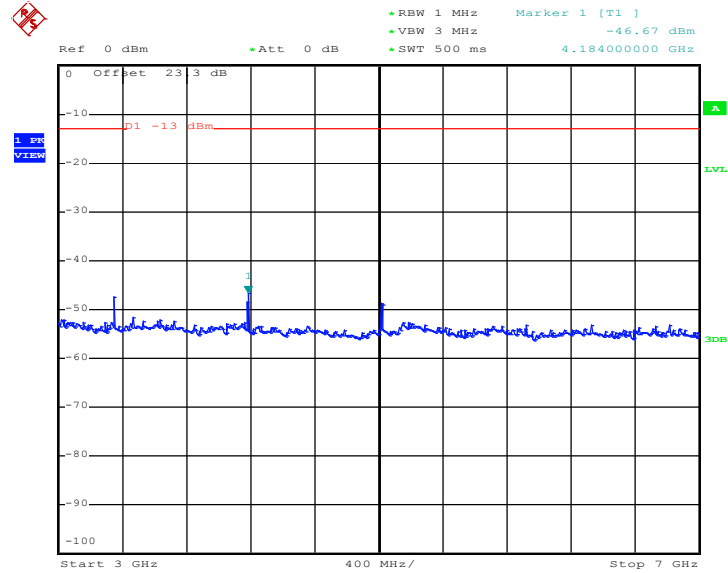

Date: 8.MAR.2013 23:59:58

Conducted Spurious Emission Plot between 7GHz ~ 9GHz

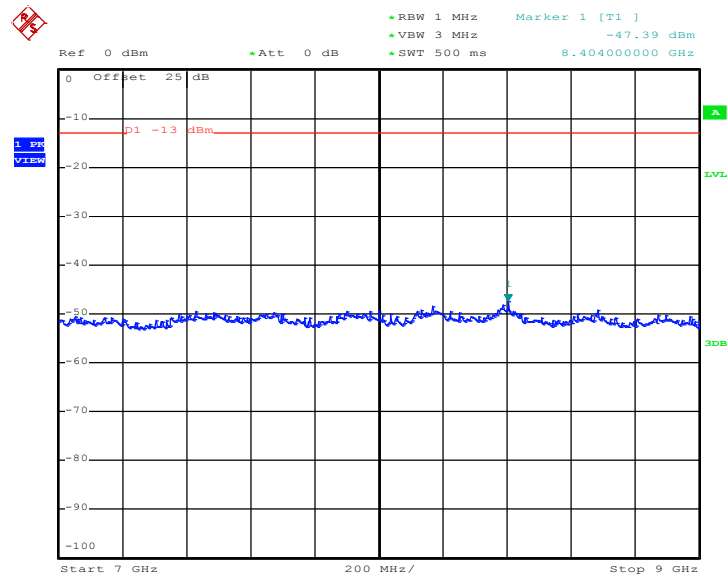

Date: 9.MAR.2013 00:00:10



Band :	CDMA2000 BC1	Channel	600
Test Mode :	1xEV-DO Rev. 0_RTAP 153.6K (QPSK)	Frequency :	1880.0 MHz

Conducted Spurious Emission Plot between 30MHz ~ 1GHz

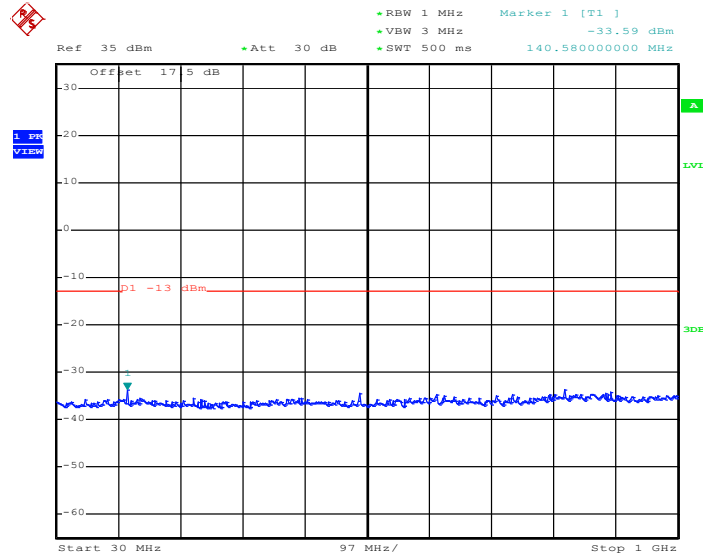

Date: 8.MAR.2013 14:18:52

Conducted Spurious Emission Plot between 1GHz ~ 3GHz

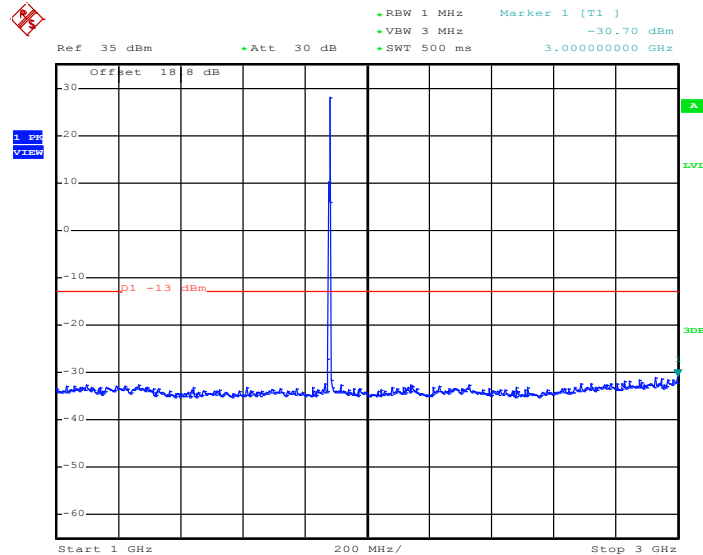

Date: 8.MAR.2013 14:19:04



Conducted Spurious Emission Plot between 3GHz ~ 7GHz

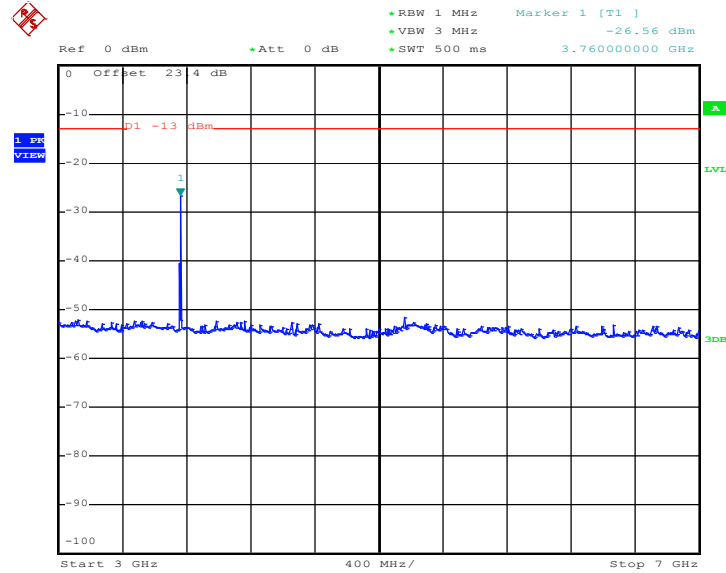

Date: 8.MAR.2013 14:19:21

Conducted Spurious Emission Plot between 7GHz ~ 13.6GHz

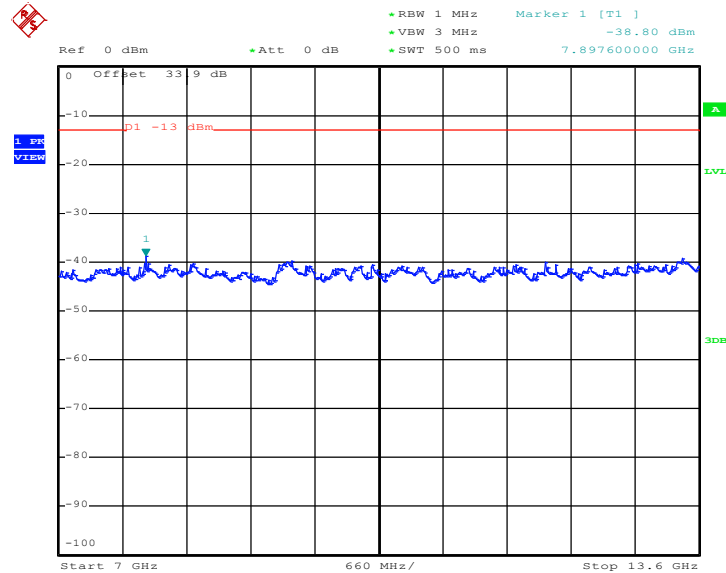

Date: 8.MAR.2013 14:19:33



Conducted Spurious Emission Plot between 13.6GHz ~ 19.1GHz

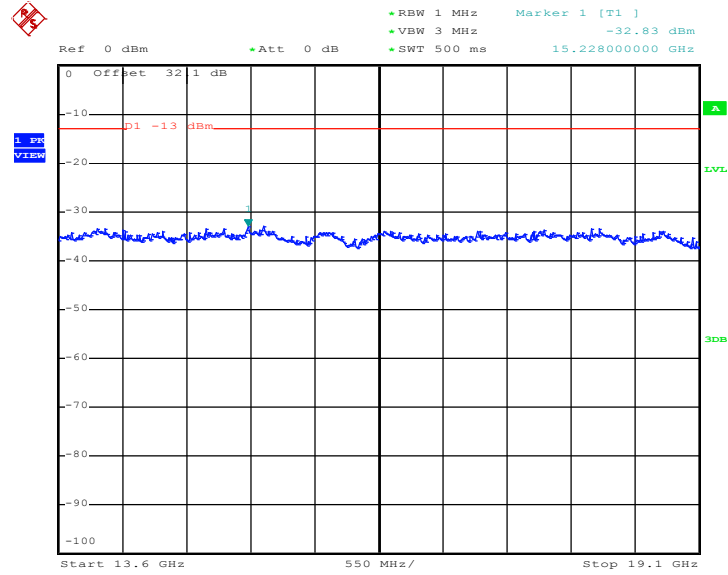

Date: 8.MAR.2013 14:19:46

3.6 Field Strength of Spurious Radiation Measurement

3.6.1 Description of Field Strength of Spurious Radiated Measurement

The power of any emission outside of the authorized operating frequency ranges must be attenuated below the transmitter power (P) by a factor of at least $43+10\log_{10}(P[\text{Watts}])$ dB. The spectrum is scanned from 30 MHz up to a frequency including its 10th harmonic.

3.6.2 Measuring Instruments

See list of measuring instruments of this test report.

3.6.3 Test Procedures

1. The EUT was placed on a rotatable wooden table with 0.8 meter above ground.
2. The EUT was set 3 meters from the receiving antenna, which was mounted on the antenna tower.
3. The table was rotated 360 degrees to determine the position of the highest spurious emission.
4. The height of the receiving antenna is varied between one meter and four meters to search the maximum spurious emission for both horizontal and vertical polarizations.
5. Make the measurement with the spectrum analyzer's RBW = 1MHz, VBW = 3MHz, taking the record of maximum spurious emission.
6. A horn antenna was substituted in place of the EUT and was driven by a signal generator.
7. Tune the output power of signal generator to the same emission level with EUT maximum spurious emission.
8. Taking the record of output power at antenna port.
9. Repeat step 7 to step 8 for another polarization.
10. $\text{EIRP (dBm)} = \text{S.G. Power} - \text{Tx Cable Loss} + \text{Tx Antenna Gain}$
11. $\text{ERP (dBm)} = \text{EIRP} - 2.15$
12. The RF fundamental frequency should be excluded against the limit line in the operating frequency band.
13. The limit line is derived from $43 + 10\log(P)$ dB below the transmitter power P(Watts)
 $= P(W) - [43 + 10\log(P)]$ (dB)
 $= [30 + 10\log(P)]$ (dBm) - $[43 + 10\log(P)]$ (dB)
 $= -13\text{dBm}$.

3.6.4 Test Setup

For radiated emissions below 30MHz

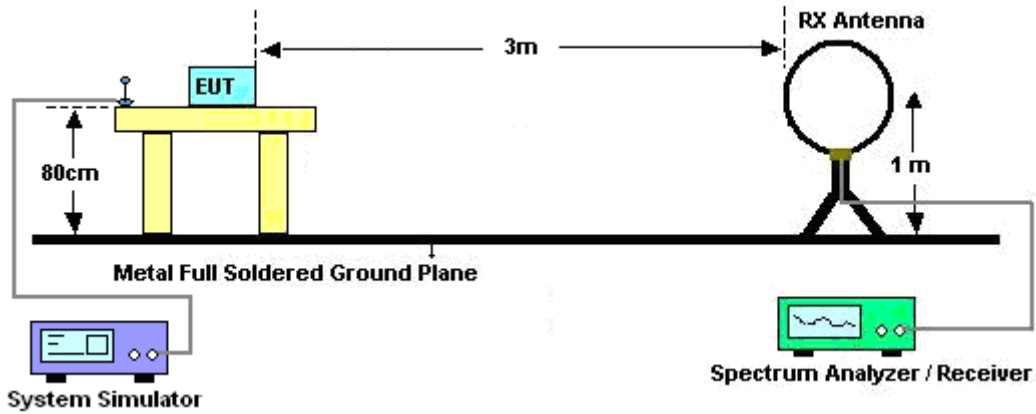

For radiated emissions from 30MHz to 1GHz

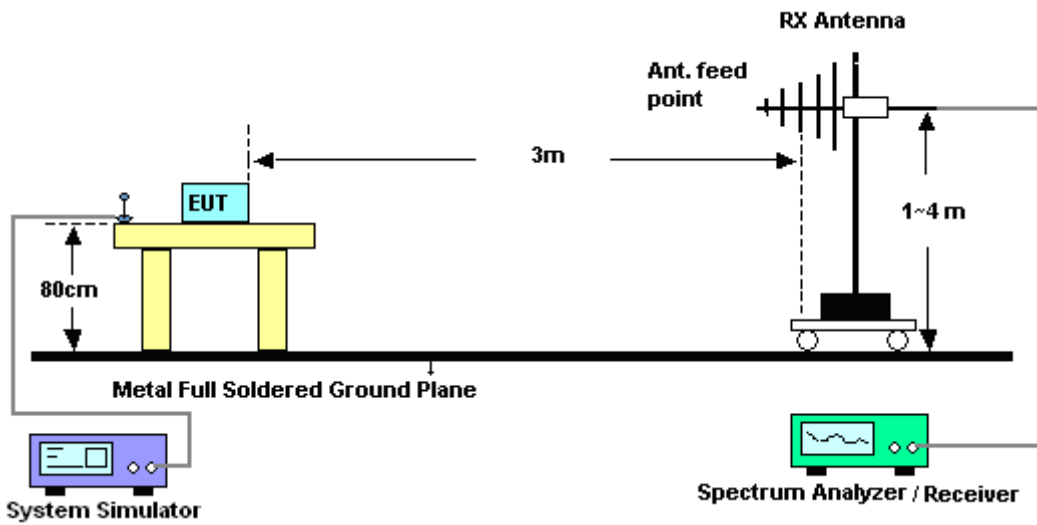

For radiated emissions above 1GHz

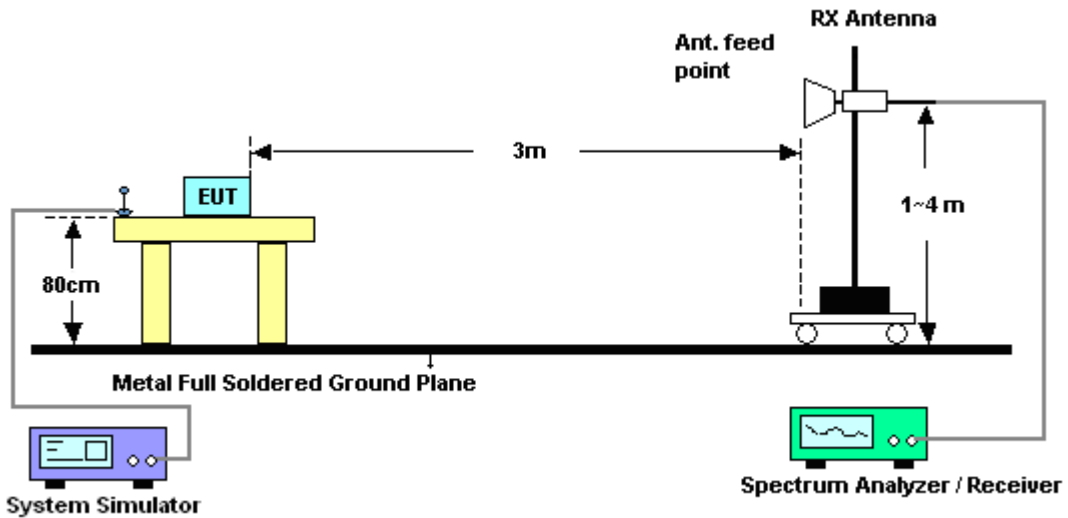

3.6.5 Test Results of Radiated Emissions (9 KHz ~ 30 MHz)

The low frequency, which started from 9 KHz to 30MHz, was pre-scanned and the result which was 20dB lower than the limit line per 15.31(o) was not reported.



3.6.6 Test Result of Field Strength of Spurious Radiated

Band :	CDMA2000 BC0	Temperature :	22~24°C
Test Mode :	1xEV-DO Rev. 0_RTAP 153.6K (QPSK)	Relative Humidity :	57~59%
Test Engineer :	David Yang	Polarization :	Horizontal
Remark :	Spurious emissions within 30-1000MHz were found more than 20dB below limit line.		

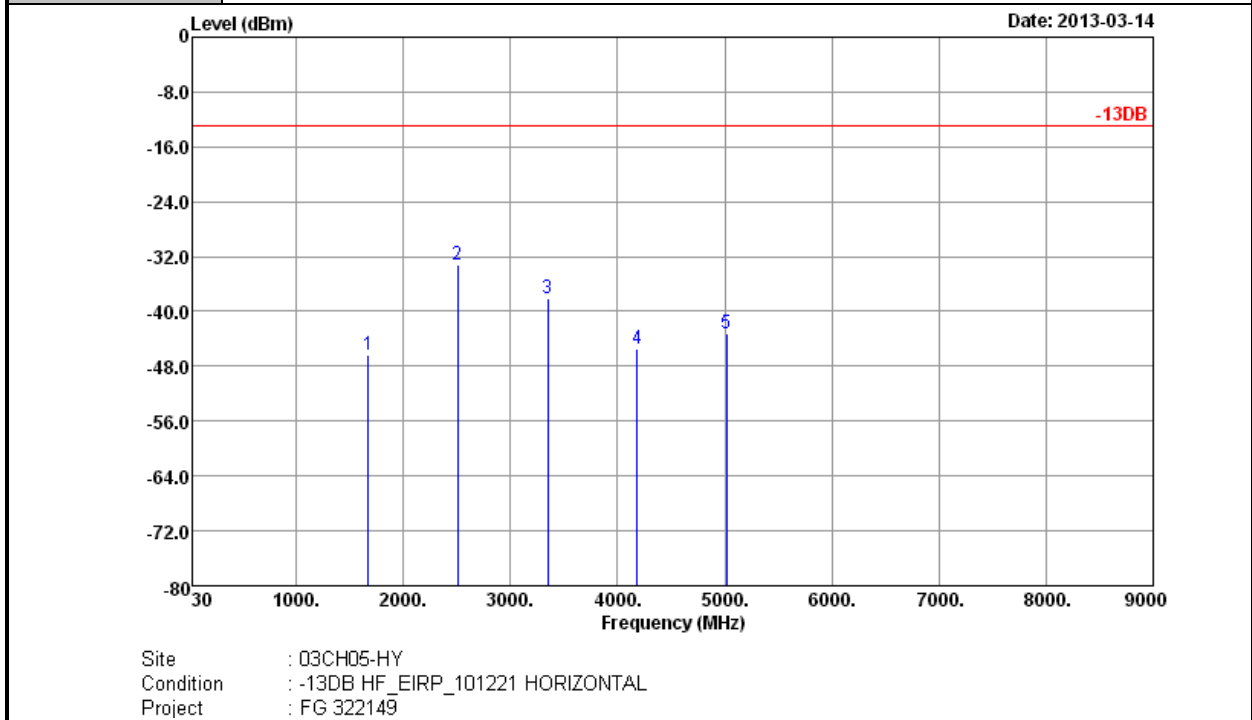

Frequency (MHz)	ERP (dBm)	Limit (dBm)	Over Limit (dB)	SPA Reading (dBm)	S.G. Power (dBm)	TX Cable loss (dB)	TX Antenna Gain (dBi)	Polarization (H/V)	Result
1672	-46.40	-13	-33.40	-53.19	-48.16	1.35	5.25	H	Pass
2509	-33.26	-13	-20.26	-44.09	-35.64	1.58	6.12	H	Pass
3349	-38.10	-13	-25.10	-51.25	-41.95	1.94	7.94	H	Pass
4180	-45.43	-13	-32.43	-61.49	-50.47	1.96	9.15	H	Pass
5015	-43.18	-13	-30.18	-61.93	-49.36	2.08	10.42	H	Pass



Band :	CDMA2000 BC0	Temperature :	22~24°C
Test Mode :	1xEV-DO Rev. 0_RTAP 153.6K (QPSK)	Relative Humidity :	57~59%
Test Engineer :	David Yang	Polarization :	Vertical
Remark :	Spurious emissions within 30-1000MHz were found more than 20dB below limit line.		

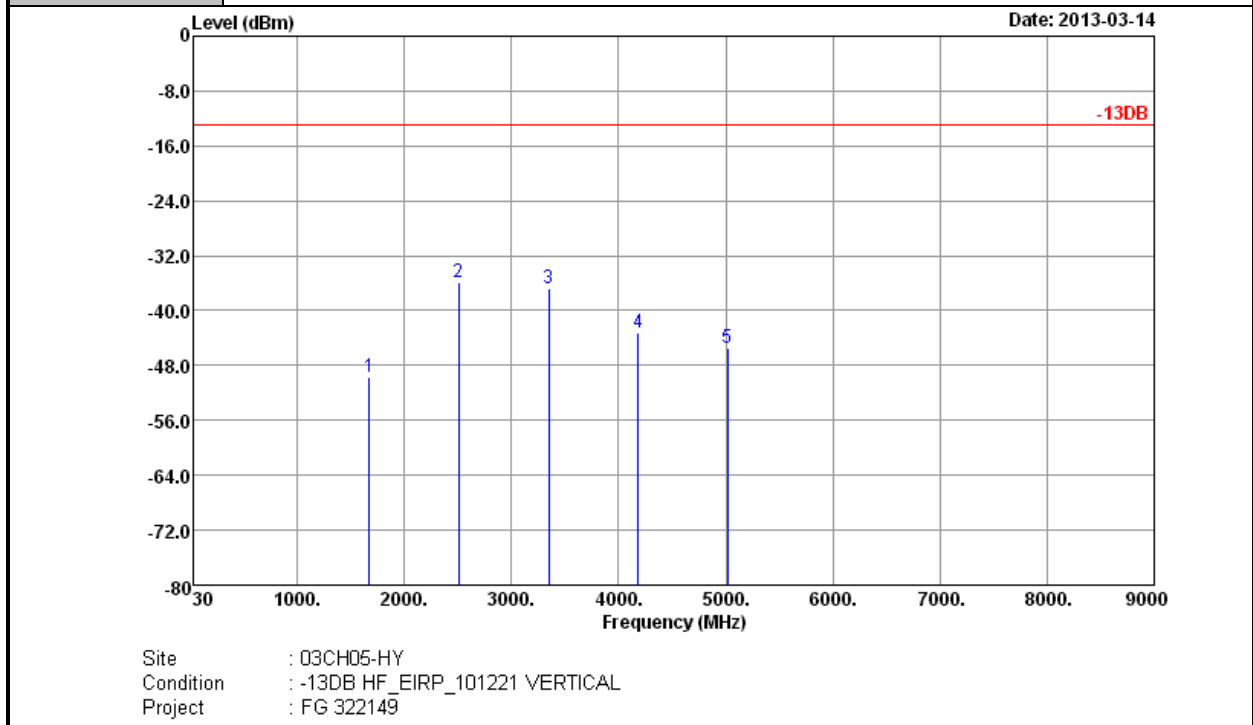

Frequency (MHz)	ERP (dBm)	Limit (dBm)	Over Limit (dB)	SPA Reading (dBm)	S.G. Power (dBm)	TX Cable loss (dB)	TX Antenna Gain (dBi)	Polarization (H/V)	Result
1672	-49.66	-13	-36.66	-55.99	-51.42	1.35	5.25	V	Pass
2509	-35.91	-13	-22.91	-46.02	-38.29	1.58	6.12	V	Pass
3349	-36.73	-13	-23.73	-49.29	-40.58	1.94	7.94	V	Pass
4180	-43.32	-13	-30.32	-59.37	-48.36	1.96	9.15	V	Pass
5015	-45.57	-13	-32.57	-63.78	-51.75	2.08	10.42	V	Pass



Band :	CDMA2000 BC1	Temperature :	22~24°C
Test Mode :	1xEV-DO Rev. 0_RTAP 153.6K (QPSK)	Relative Humidity :	57~59%
Test Engineer :	David Yang	Polarization :	Horizontal
Remark :	Spurious emissions within 30-1000MHz were found more than 20dB below limit line.		

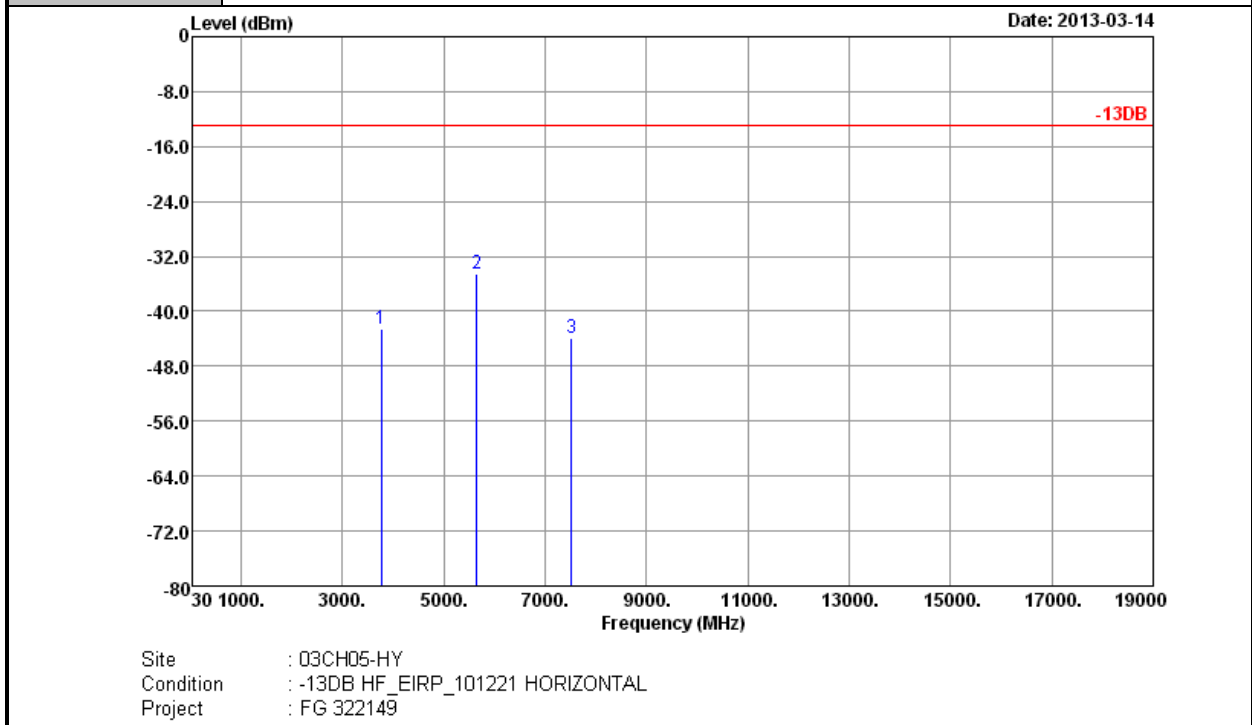

Frequency (MHz)	EIRP (dBm)	Limit (dBm)	Over Limit (dB)	SPA Reading (dBm)	S.G. Power (dBm)	TX Cable loss (dB)	TX Antenna Gain (dBi)	Polarization (H/V)	Result
3760	-42.65	-13	-29.65	-57.17	-49.36	2.00	8.71	H	Pass
5640	-34.64	-13	-21.64	-54.44	-43.28	2.13	10.77	H	Pass
7520	-43.90	-13	-30.90	-66.86	-53.44	2.68	12.22	H	Pass



Band :	CDMA2000 BC1	Temperature :	22~24°C
Test Mode :	1xEV-DO Rev. 0_RTAP 153.6K (QPSK)	Relative Humidity :	57~59%
Test Engineer :	David Yang	Polarization :	Vertical
Remark :	Spurious emissions within 30-1000MHz were found more than 20dB below limit line.		

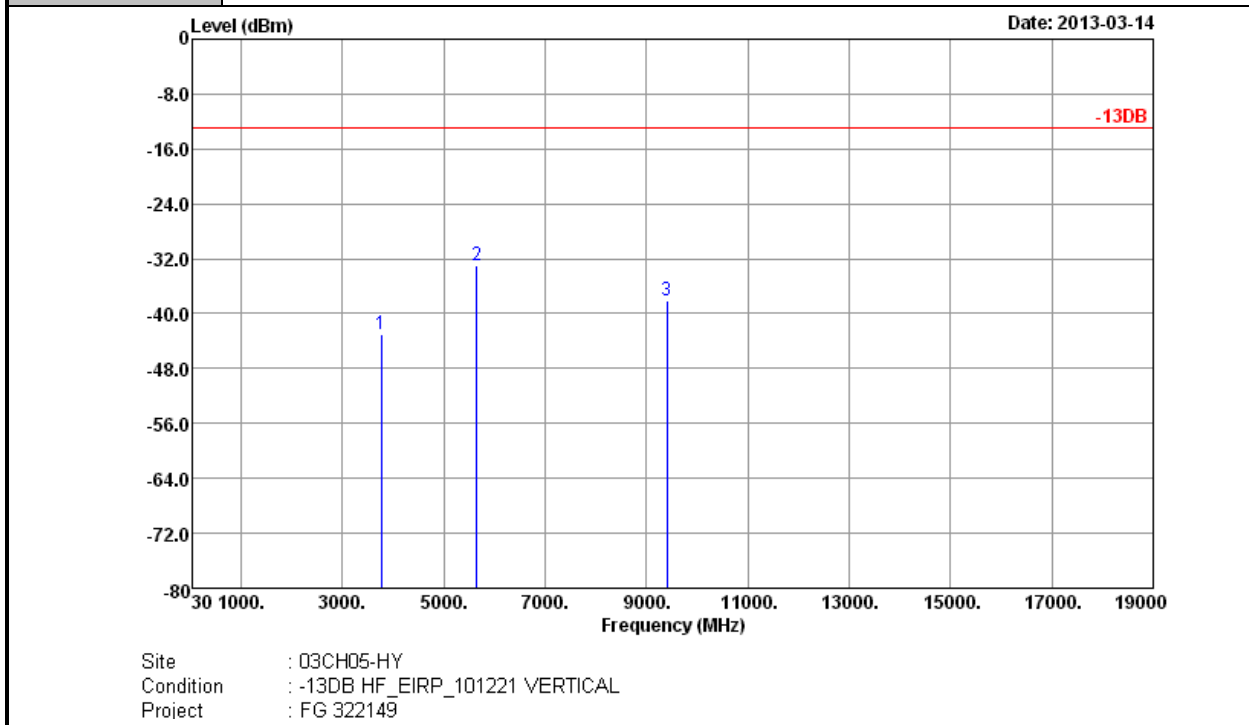

Frequency (MHz)	EIRP (dBm)	Limit (dBm)	Over Limit (dB)	SPA Reading (dBm)	S.G. Power (dBm)	TX Cable loss (dB)	TX Antenna Gain (dBi)	Polarization (H/V)	Result
3760	-43.05	-13	-30.05	-57.43	-49.76	2.00	8.71	V	Pass
5640	-32.88	-13	-19.88	-51.98	-41.52	2.13	10.77	V	Pass
9404	-38.12	-13	-25.12	-63.56	-48.63	2.87	13.38	V	Pass

3.7 Frequency Stability Measurement

3.7.1 Description of Frequency Stability Measurement

The frequency stability shall be measured by variation of ambient temperature and variation of primary supply voltage to ensure that the fundamental emission stays within the authorized frequency block. The frequency stability of the transmitter shall be maintained within $\pm 0.00025\%$ ($\pm 2.5\text{ppm}$) of the center frequency.

3.7.2 Measuring Instruments

See list of measuring instruments of this test report.

3.7.3 Test Procedures for Temperature Variation

1. The EUT was set up in the thermal chamber and connected with the base station.
2. With power OFF, the temperature was decreased to -30°C and the EUT was stabilized before testing. Power was applied and the maximum change in frequency was recorded within one minute.
3. With power OFF, the temperature was raised in 10°C step up to 50°C . The EUT was stabilized at each step for at least half an hour. Power was applied and the maximum frequency change was recorded within one minute.
4. If the EUT cannot be turned on at -30°C , the testing lowest temperature will be raised in 10°C step until the EUT can be turned on.

3.7.4 Test Procedures for Voltage Variation

1. The EUT was placed in a temperature chamber at $25\pm 5^{\circ}\text{C}$ and connected with the base station.
2. The power supply voltage to the EUT was varied from BEP to 115% of the nominal value measured at the input to the EUT.
3. The variation in frequency was measured for the worst case.

3.7.5 Test Setup

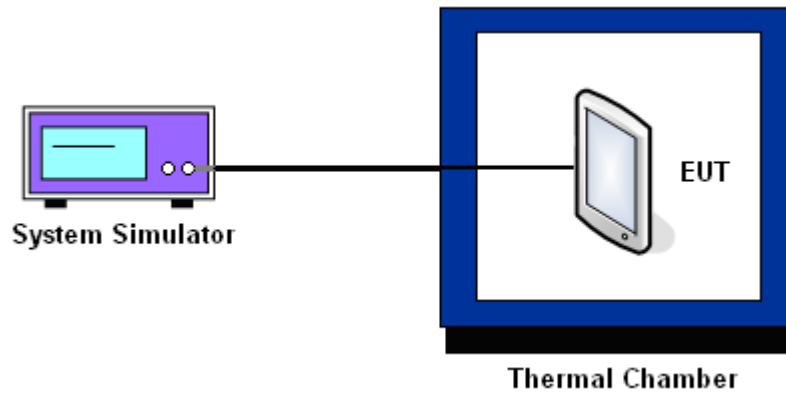



3.7.6 Test Result of Temperature Variation

Band :	CDMA2000 BC0 1xEV-DO Rev. 0_RTAP 153.6K	Channel :	384
Limit (ppm) :	2.5	Frequency :	836.52 MHz

Temperature (°C)	Freq. Dev. (Hz)	Deviation (ppm)	Result
-30	-18	-0.02	PASS
-20	-13	-0.02	
-10	19	0.02	
0	17	0.02	
10	15	0.02	
20	18	0.02	
30	-22	-0.03	
40	21	0.02	
50	25	0.03	

Band :	CDMA2000 BC1 1xEV-DO Rev. 0_RTAP 153.6K	Channel :	600
Limit (ppm) :	2.5	Frequency :	1880.0 MHz

Temperature (°C)	Freq. Dev. (Hz)	Deviation (ppm)	Result
-30	-14	-0.01	PASS
-20	-13	-0.01	
-10	-12	-0.01	
0	-15	-0.01	
10	-14	-0.01	
20	-16	-0.01	
30	-17	-0.01	
40	-20	-0.01	
50	-21	-0.01	



3.7.7 Test Result of Voltage Variation

Band & Channel	Mode	Voltage (Volt)	Freq. Dev. (Hz)	Deviation (ppm)	Limit (ppm)	Result
CDMA2000 BC0 CH384	1xEV-DO Rev. 0 RTAP 153.6K	19.00	15	0.02	2.5	PASS
		BEP	-14	-0.02		
		19.95	18	0.02		
CDMA2000 BC1 CH600	1xEV-DO Rev. 0 RTAP 153.6K	19.00	-20	-0.01	2.5	PASS
		BEP	-18	-0.01		
		19.95	-21	-0.01		

Note :

- 1. Normal Voltage = 19.00V.
- 2. Battery End Point (BEP) = 18.05 V.



4 List of Measuring Equipment

Instrument	Manufacturer	Model No.	Serial No.	Characteristics	Calibration Date	Test Date	Due Date	Remark
System Simulator	R&S	CMU200	117995	N/A	Jul. 30, 2012	Mar. 08, 2013 ~ Mar. 09, 2013	Jul. 29, 2013	Conducted (TH02-HY)
Spectrum Analyzer	R&S	FSP40	100055	9kHz~40GHz	Jun. 06, 2012	Mar. 08, 2013 ~ Mar. 09, 2013	Jun. 05, 2013	Conducted (TH02-HY)
Thermal Chamber	Ten Billion	TTH-D3SP	TBN-930701	N/A	Jul. 23, 2012	Mar. 08, 2013 ~ Mar. 09, 2013	Jul. 22, 2013	Conducted (TH02-HY)
Spectrum Analyzer	R&S	ESU26	100390	20Hz~26.5GHz	Dec. 14, 2012	Mar. 14, 2013	Dec. 13, 2013	Radiation (03CH05-HY)
Bilog Antenna	Schaffner	CBL6111C	2725	30MHz~2GHz	Oct. 06, 2012	Mar. 14, 2013	Oct. 05, 2013	Radiation (03CH05-HY)
Turn Table	HD	Deis HD 2000	420/611	0 ~ 360 degree	N/A	Mar. 14, 2013	N/A	Radiation (03CH05-HY)
Antenna Mast	HD	MA 240	240/666	1 m ~ 4 m	N/A	Mar. 14, 2013	N/A	Radiation (03CH05-HY)
Horn Antenna	ESCO	3117	66584	1GHz~18GHz	Aug. 10, 2012	Mar. 14, 2013	Aug. 09, 2013	Radiation (03CH05-HY)
Pre Amplifier	Agilent	8449B	3008A02665	1GHz~26.5GHz	Aug. 28, 2012	Mar. 14, 2013	Aug. 27, 2013	Radiation (03CH05-HY)
SHF-EHF Horn Antenna	SCHWARZBECK	BBHA 9170	BBHA917025 1	15GHz ~ 40GHz	Sep. 28, 2012	Mar. 14, 2013	Sep. 27, 2013	Radiation (03CH05-HY)
Preamplifier	COM-POWER	PA-103	161075	10Hz~1000MHz Gain:32dB	Feb. 26, 2013	Mar. 14, 2013	Feb. 25, 2014	Radiation (03CH05-HY)
Loop Antenna	R&S	HFH2-Z2	860004/001	9KHz ~ 30MHz	Jul. 03, 2012	Mar. 14, 2013	Jul. 02, 2013	Radiation (03CH05-HY)
System Simulator	Agilent	E5515C (8960)	MY48360820	N/A	Jan. 05, 2012	Mar. 14, 2013	Jan. 04, 2014	Radiation (03CH05-HY)



5 Uncertainty of Evaluation

Uncertainty of Radiated Emission Measurement (30 MHz ~ 1000 MHz)

Measuring Uncertainty for a Level of Confidence of 95% ($U = 2Uc(y)$)	2.54
---	------

Uncertainty of Radiated Emission Measurement (1 GHz ~ 40 GHz)

Measuring Uncertainty for a Level of Confidence of 95% ($U = 2Uc(y)$)	4.72
---	------



Appendix A. Photographs of EUT

Please refer to Sporton report number EP322149 as below.