Low cost PCB antenna for 2.4 GHz radio: meander design for STM32WB Series

Introduction

This application note is dedicated to the STM32WB Series microcontrollers.

One of the main reasons to use a PCB (printed circuit board) antenna is the reduced overall cost of the radio module. Well designed and implemented PCB-printed antennas have a similar performance to the SMD (surface-mounted device) ceramic equivalence.

In general, the footprint for a ceramic SMD antenna is smaller than that for a PCB-printed variant. For a PCB-printed antenna solution, the increased size of the PCB in relation to space required for the antenna means that the radio module is larger and the cost of the PCB increased. However the PCB solution is generally cheaper than a SMD ceramic antenna.

The demonstration and development boards for the STM32WB Series implement PCB printed antenna based on this application note.

1 General information

This document applies to STM32WB Series Arm[®]-based devices.

Note: Arm is a registered trademark of Arm Limited (or its subsidiaries) in the US and/or elsewhere.



2 Coordinate system

For the purpose of this document, the spherical coordinate system illustrated in the figure below is used.

Figure 1. Spherical coordinate system

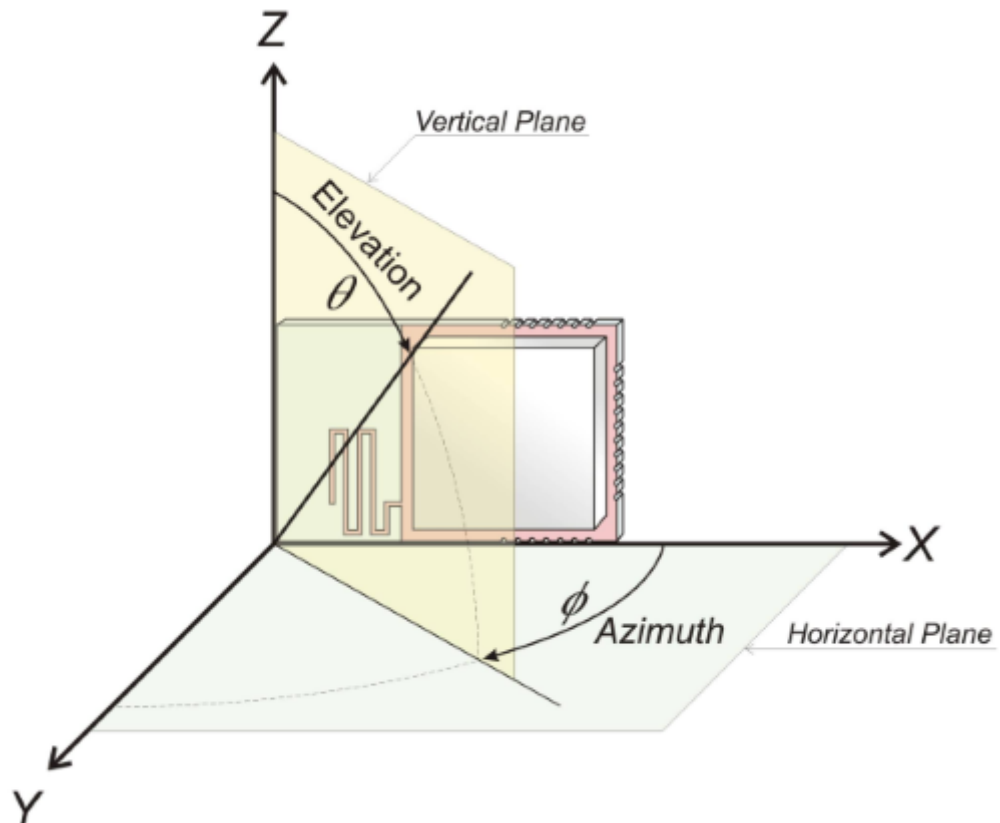

The PCB module is orientated vertically (plane X-Z) and located in proximity to the origin of the coordinate system. The azimuth angle radiates from the X-axis towards the Y-axis and the elevation angle radiates from the Z-axis towards the horizontal X-Y plane.

Sometimes, as with geographical and navigational systems, the X-axis is called the "Nord-axis", the Y-axis is called the "East-axis" and the Z-axis is called the "Zenith-axis".

The figure below illustrates a typical cross-section of the substrate in a PCB-antennae area.

Figure 3. PCB cross section at antennae area

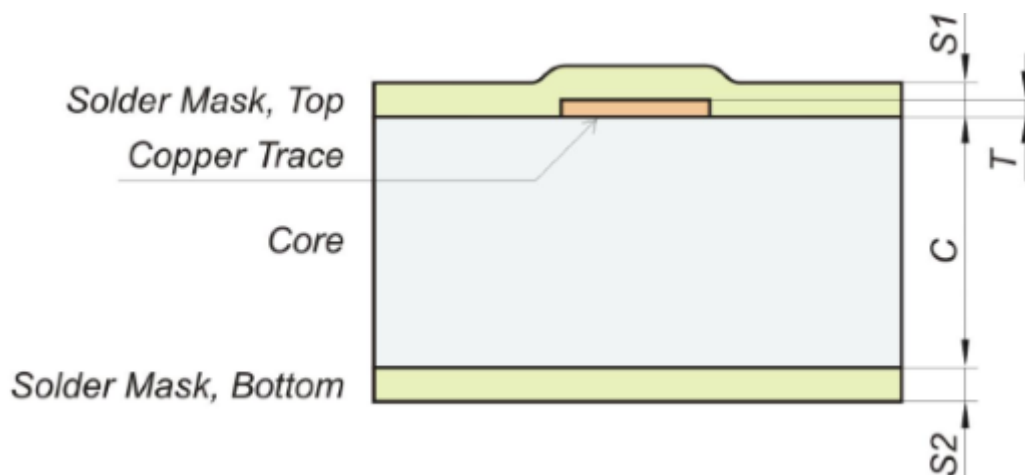

A substrate with the parameters as defined in the table below is recommended.

Table 1. Recommended substrate specification

Layer	Dimensions			Dielectric constant ϵ_R
	Label	Value (mil)	Value (μm)	
Solder mask, top	S1	0.7	17.78	4.4
Copper trace	T	1.6	40.64	-
Core	C	28	711.2	4.4
Solder mask, bottom	S2	0.7	17.78	4.4

4 Impedance matching

Meander-like PCB antenna can be tuned to the required 50 Ω impedance by matching the impedance circuitry with the π topology. In Figure 2, the impedance matching area is marked with a dashed line. Under nominal conditions, this antenna exhibits an impedance very close to the required nominal impedance (50 Ω).

To check the performance of this design, a sample antenna was manufactured (according to the specifications covered by this document). The figure below shows this antenna.

Figure 4. Part of 802.15.4 and BLE PCB with meander-like antenna (scale around 4:1)



Assuming that the manufactured sample exhibits the expected performance (no impedance matching necessary), the impedance matching circuitry is bypassed by two 100 pF capacitors connected in series, as shown in the figure below.

Figure 5. Bypassing impedance matching circuitry - Direct RF connection

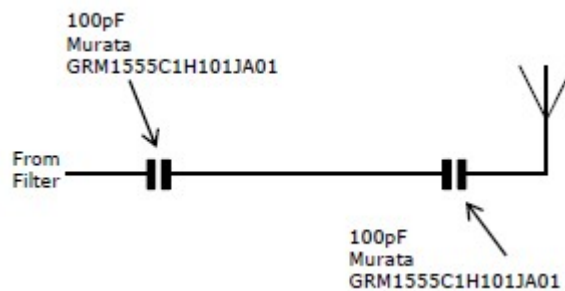

All electrical parameters of the meander-like antenna have been measured at connection to the band-pass filter (BPF) with the frequency span covering frequencies from 2.4 GHz to 2.5 GHz.

Complex impedance of the antenna is shown in the Smith diagram in the figure below.

Figure 6. Complex impedance of the meander-like antenna (Smith chart)

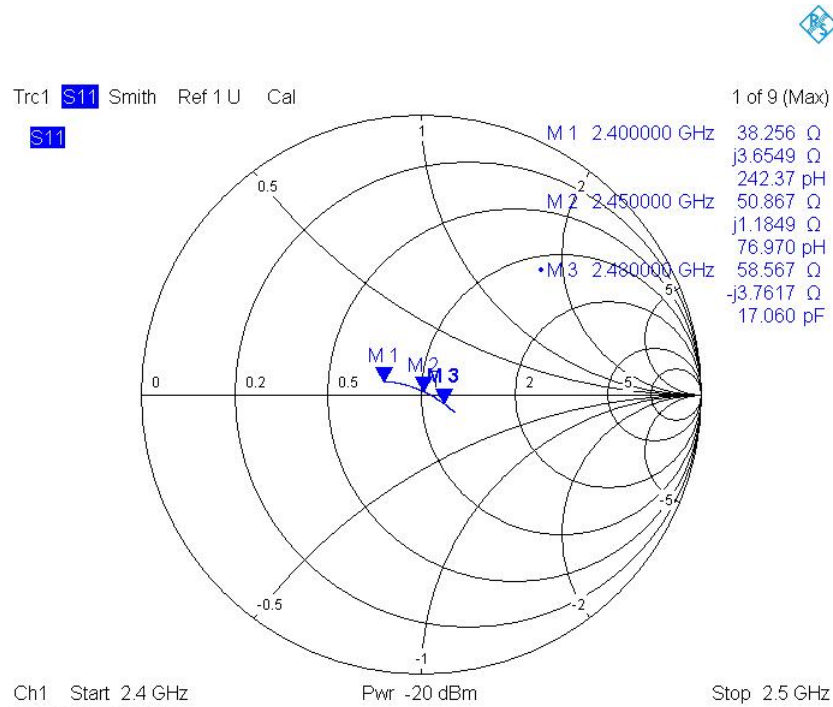

The figure below shows the magnitude of the S11 parameter (in log scale).

Figure 7. S11 parameter in logarithmic scale (Cartesian plot)

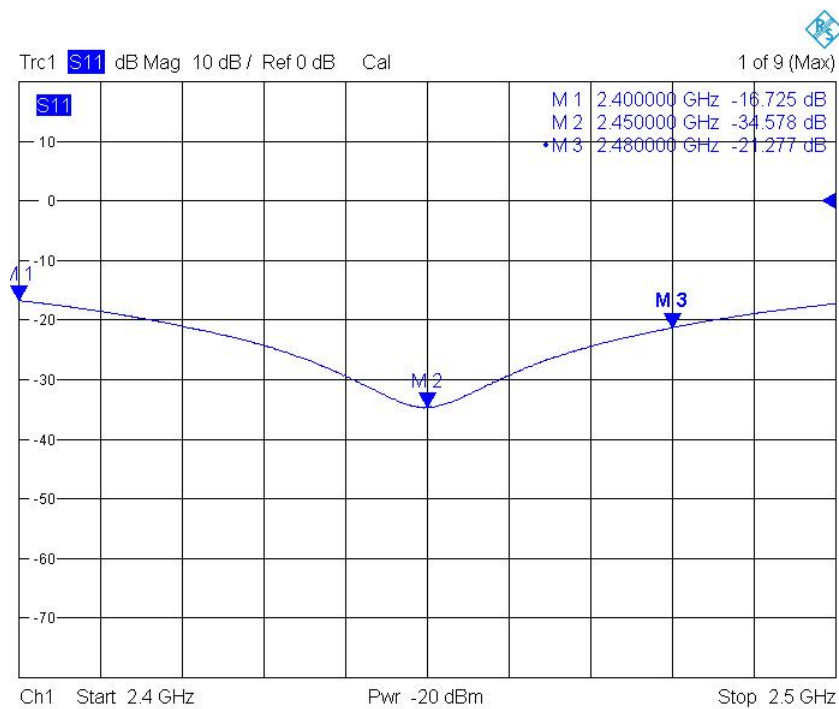

The figure below shows the standing wave ratio (SWR).

Figure 8. Antenna standing wave ratio (SWR)

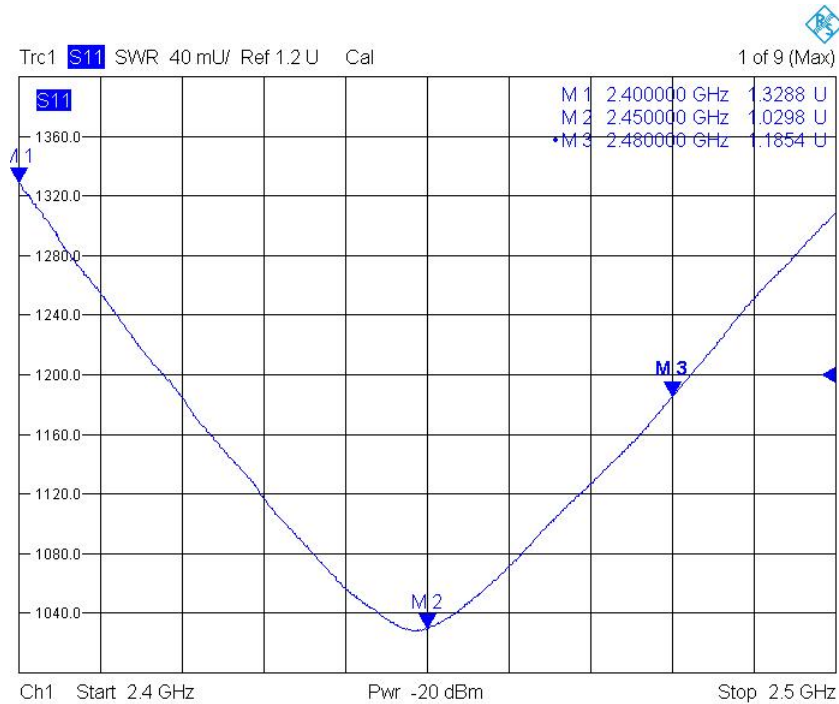

The following changes affect the radiation impedance of the PCB antenna:

- slight board size variation
- metal shielding
- use of plastic cover
- presence of other components in proximity of the antenna

The best performance impedance matching circuitry compensates these effects so that, for operating frequencies, the optimum 50 Ω impedance is achieved.

5 Radiation pattern, 3-D visualization

A three-dimensional (3-D) visualization of the radiation pattern (magnitude of the electrical far field $|E|$) is done for the center ISM band frequency 2.44175 GHz.

Figure 9. 3-D radiation pattern overview

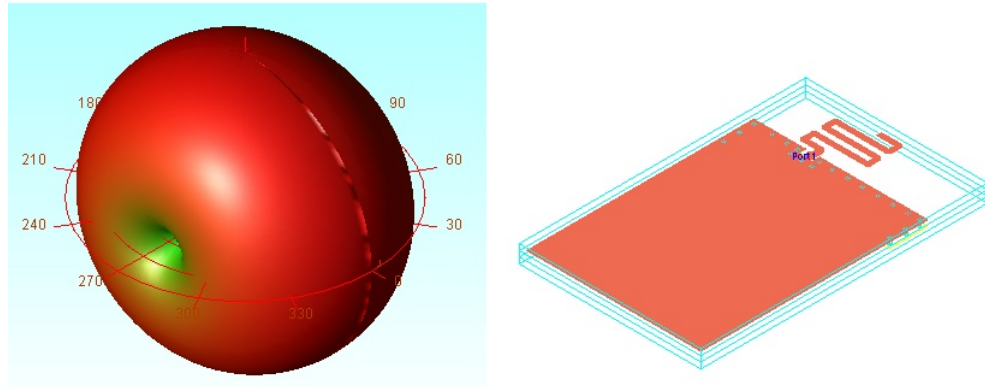
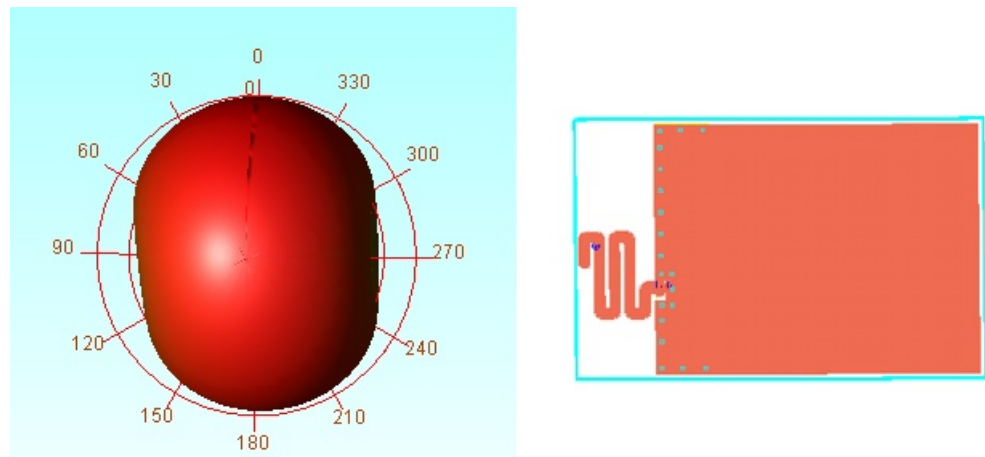

Figure 10. Radiation pattern on X-Z plane



6 Radiation pattern, 2-D visualization

In this section, all radiation patterns are related to the magnitude of electrical far field $|E|$, that is normalized and shown in the logarithmic scale (in dB). This means that the maximum global radiation pattern (maximum magnitude of the electrical far-field E) is represented by 0 dB level.

To show the antenna radiation patterns in detail, three two dimensional (2-D) major cuts are presented. Consider the orientation of the module in the spherical coordinate system as shown in [Figure 1](#).

A three dimensional (3-D) far field radiation pattern is visualized as three two dimensional (2-D) cuts through a 3-D pattern. The following major planes are used for these cuts (see [Figure 11](#)):

- one horizontal X-Y plane
- two vertical planes: X-Z plane and Y-Z plane

Colors of the plots in the figure below, are as follows:

- The "Blue" plot is drawn on the horizontal X-Y plane, where azimuth ϕ radiates from 0° on the X-axis towards the Y-axis, until it reaches 360° on the X-axis.
- The "Red" plot is drawn on the X-Z plane, where elevation θ radiates from 0° on the Z-axis towards the positive part of the X-axis, until it reaches 180° on the negative part of the Z-axis. In this plot (cut by X-Z plane), elevation θ is negative for $X < 0$.
- The "Green" plot is drawn on the Y-Z plane, where elevation θ radiates from 0° on the Z-axis towards the positive part of the Y-axis, until it reaches 180° on the negative part of the Z-axis. For this plot (cut by Y-Z plane), elevation θ is negative for $Y < 0$.

Figure 11. Major planes to visualize 3-D radiation pattern using 2-D plots

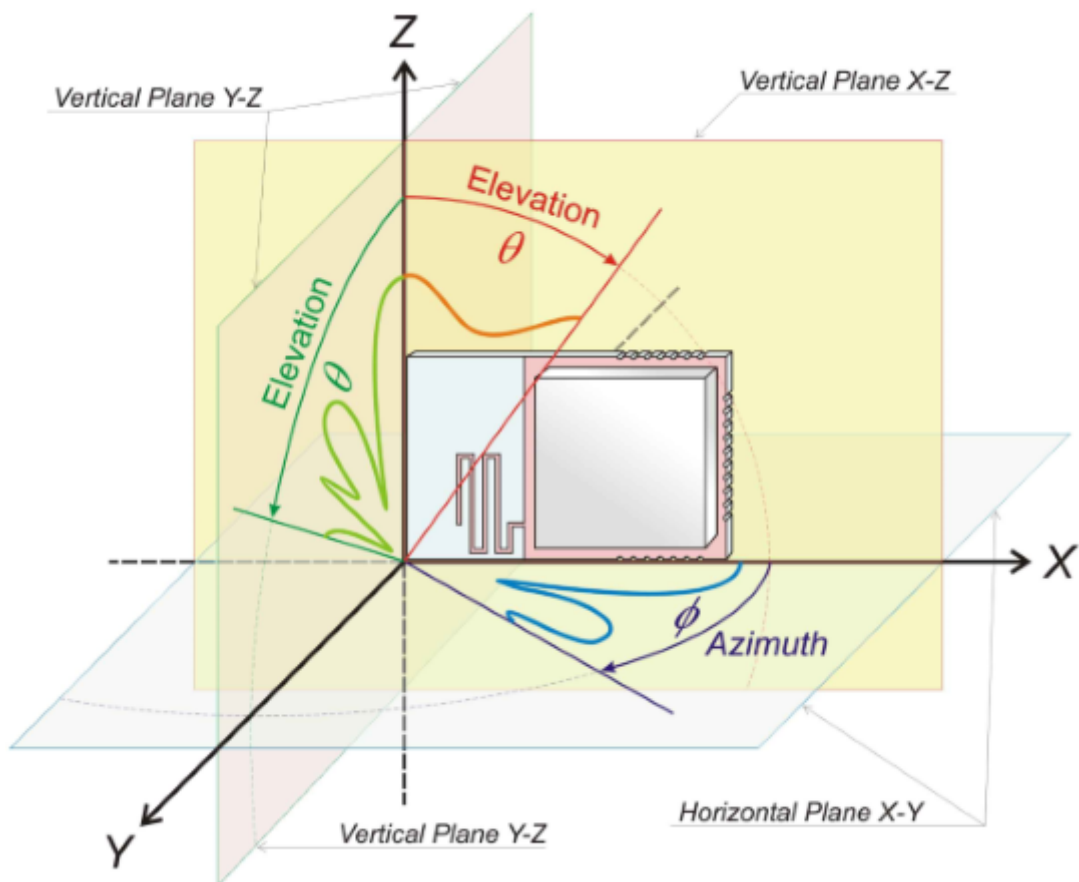

This section uses short dipole for comparison and clarification purposes only.

6.1 Radiation pattern on Y-Z plane

The first radiation patterns in Figure 13 and Figure 14 show a normal electrical field radiation pattern $|E|$ (far field) on the Y-Z plane. The module orientation versus Y-Z plane and this plot is shown in the figure below.

Figure 12. Far field radiation pattern plotted on Y-Z plane

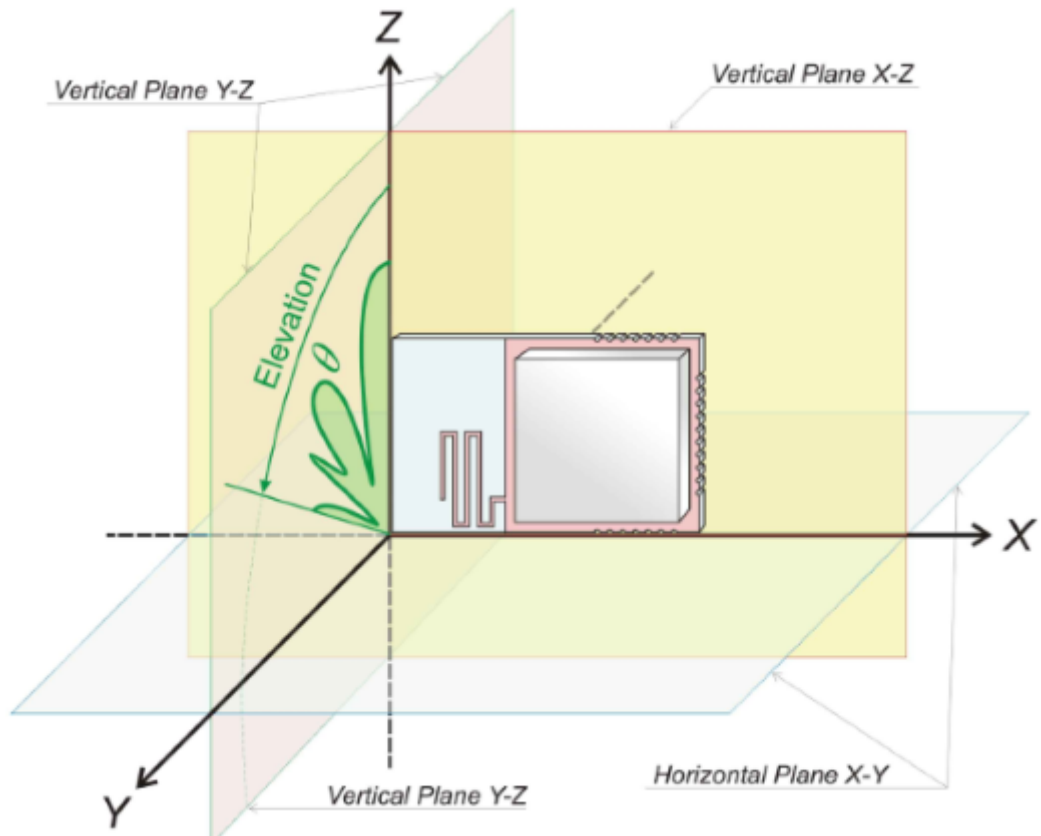

Note: The level of the radiation is nearly constant and the radiation is nearly omni-directional on this plane. For a vertically orientated dipole, this pattern is equivalent to the horizontal radiation.

Figure 13. Normalized radiation pattern on Y-Z plan (polar plot)

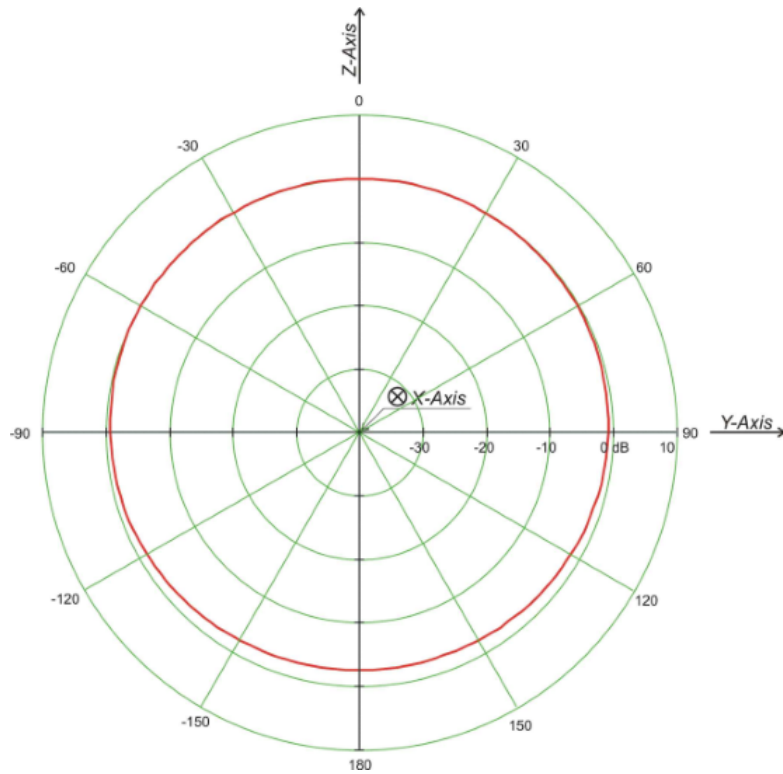

The figure below shows the same radiation pattern as in the previous figure, presented as a Cartesian plot.

Figure 14. Normalized radiation pattern on Y-Z plan (Cartesian plot)

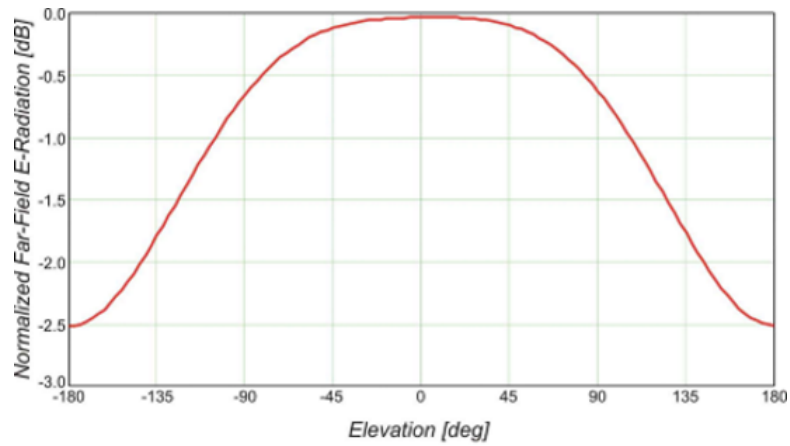

6.2 Radiation pattern on X-Y plane

The second far-field radiation patterns in Figure 16 and Figure 17 represent a normalized magnitude of the electrical field $|E|$ plotted on the X-Y plane. The module orientation versus the X-Y plane and this plot is shown in the figure below.

Figure 15. Far field radiation pattern plotted on X-Y plane

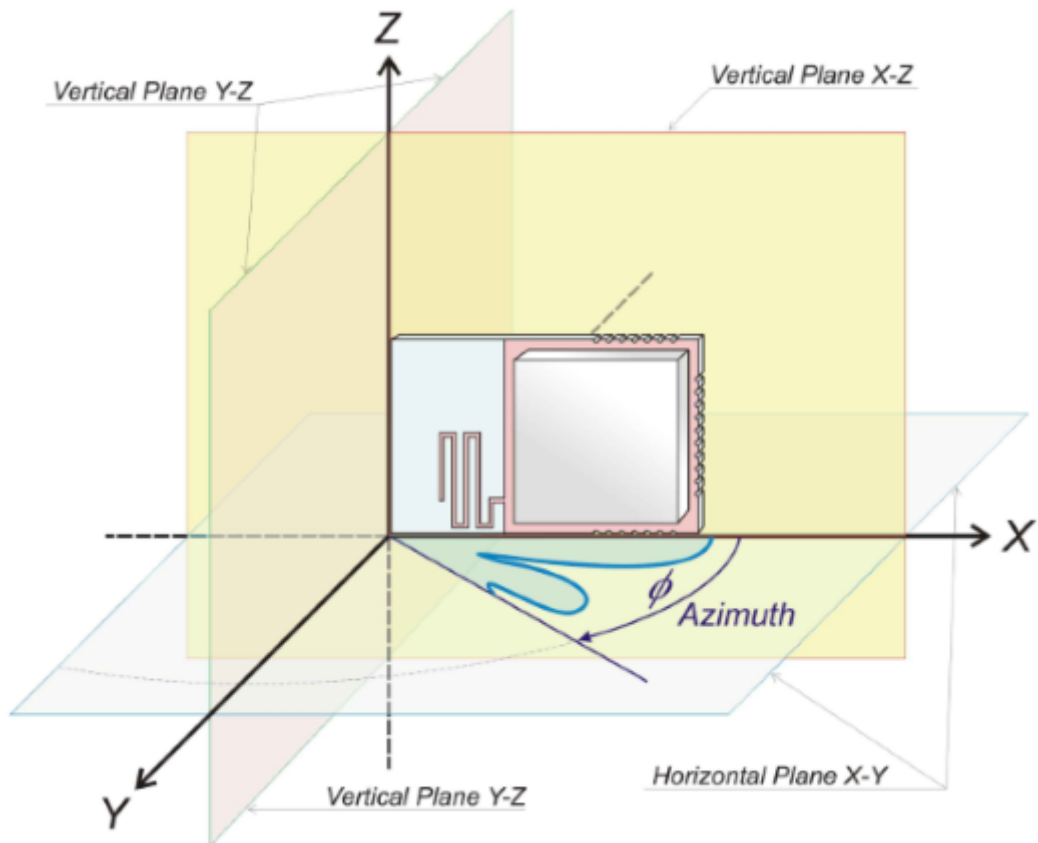

For a vertically orientated dipole, this pattern is equivalent to the vertical radiation.

Note that this solution does not present blind direction as a standard dipole will do when the receiver will be in the Z axis of the dipole antenna. In this solution the maximum attenuation is in the range of 10 to 14 dB in the worst XY direction

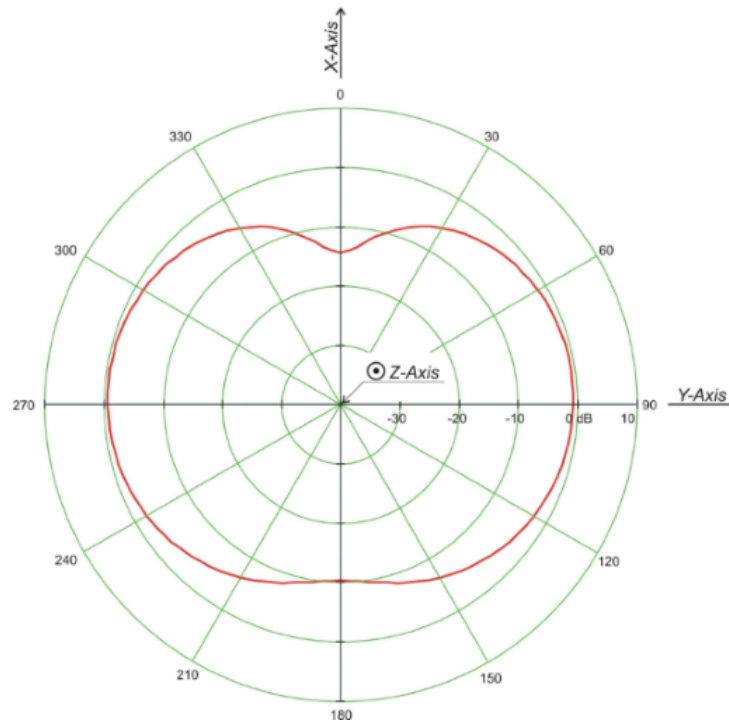
Figure 16. Normalized radiation pattern on X-Y plan (polar plot)

The figure below shows the same far $|E|$ -field radiation pattern on the X-Y plane as in the previous figure, presented as a Cartesian plot.

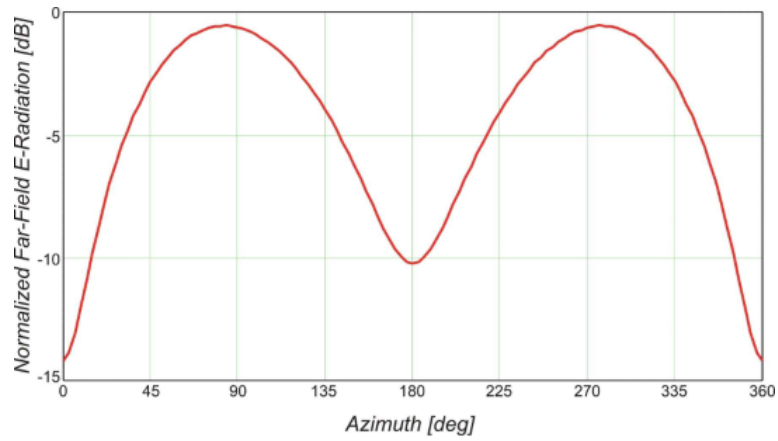
Figure 17. Normalized radiation pattern on X-Y plan (Cartesian plot)

6.3 Radiation pattern on X-Z plane

The third and last radiation patterns in Figure 19 and Figure 20 represent a normalized electrical field radiation pattern $|E|$ (far field) on the X-Z plane. The module orientation versus the X-Z plane and this plot is shown in the figure below.

Figure 18. Far field radiation pattern plotted on X-Z plane

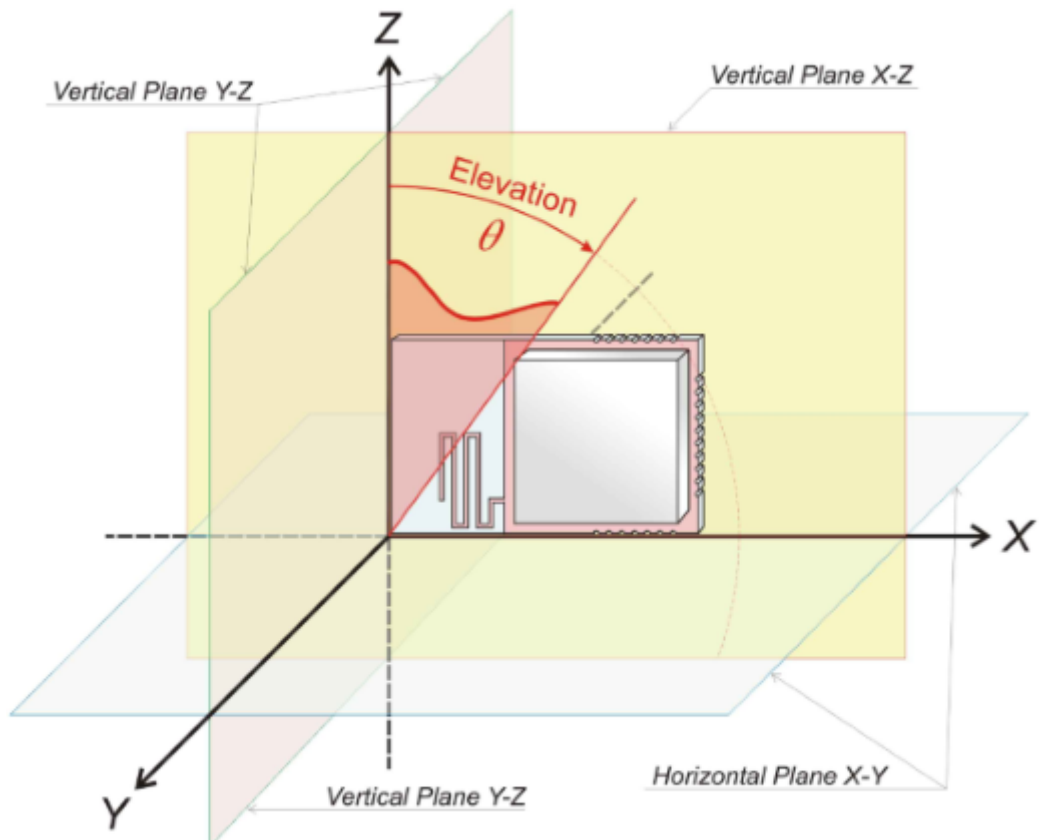

For a horizontally orientated dipole, this pattern is equivalent to the vertical radiation.

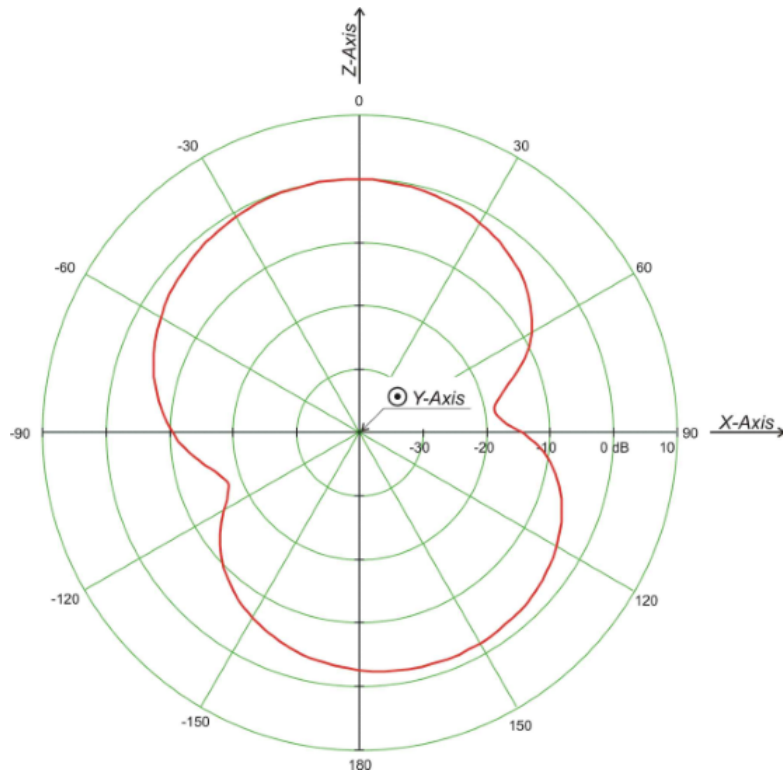
Figure 19. Normalized radiation pattern on X-Z plan (polar plot)

The figure below shows the same far electrical field radiation pattern on the X-Z plane in the previous figure, presented as a Cartesian plot.

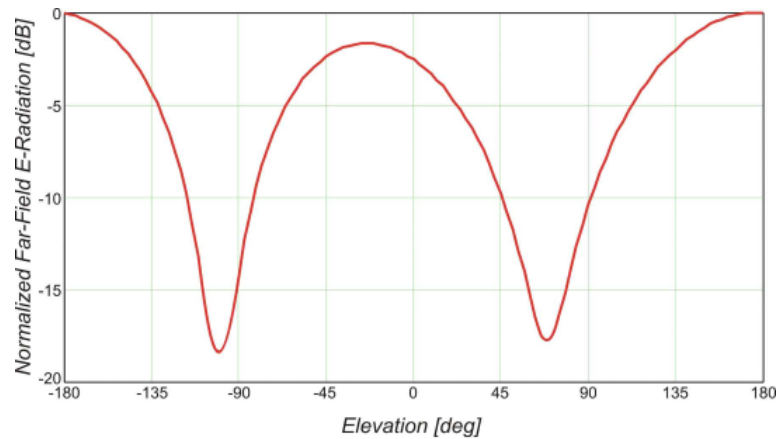
Figure 20. Normalized radiation pattern on X-Z plan (Cartesian plot)

7 Performance

At center ISM Band frequency 2.44175 GHz, the antenna shows the following key performance parameters:

- Directivity 2.21 dB
- Gain 1.95 dBi
- Maximum intensity 0.125 W/Steradian

8 Mechanical and PCB impact

The integration of such antenna in a final product can be degraded if the ground plane is too close. Enough room must be left around the antenna without ground plane.

Note: Any metallic object impacts the antenna performances and radiation pattern. In the same way, if the device is hand operated, the hand and body position of the user may impact the antenna design

Revision history

Table 2. Document revision history

Date	Version	Changes
17-Jan-2018	1	Initial release.
14-Sep-2018	2	Updated document's publishing scope.
25-Feb-2019	3	Updated document's publishing scope.
23-Apr-2019	4	Updated Figure 2. PCB antenna dimensions (in mm) .

Contents

1	General information	2
2	Coordinate system	3
3	Layout specification	4
4	Impedance matching	6
5	Radiation pattern, 3-D visualization	9
6	Radiation pattern, 2-D visualization	10
6.1	Radiation pattern on Y-Z plane	10
6.2	Radiation pattern on X-Y plane	12
6.3	Radiation pattern on X-Z plane	14
7	Performance	17
8	Mechanical and PCB impact	18
	Revision history	19
	Contents	20
	List of figures	21

List of figures

Figure 1.	Spherical coordinate system	3
Figure 2.	PCB antenna dimensions (in mm)	4
Figure 3.	PCB cross section at antennae area	5
Figure 4.	Part of 802.15.4 and BLE PCB with meander-like antenna (scale around 4:1)	6
Figure 5.	Bypassing impedance matching circuitry - Direct RF connection	6
Figure 6.	Complex impedance of the meander-like antenna (Smith chart)	7
Figure 7.	S11 parameter in logarithmic scale (Cartesian plot)	7
Figure 8.	Antenna standing wave ratio (SWR)	8
Figure 9.	3-D radiation pattern overview	9
Figure 10.	Radiation pattern on X-Z plane	9
Figure 11.	Major planes to visualize 3-D radiation pattern using 2-D plots	10
Figure 12.	Far field radiation pattern plotted on Y-Z plane	11
Figure 13.	Normalized radiation pattern on Y-Z plan (polar plot)	12
Figure 14.	Normalized radiation pattern on Y-Z plan (Cartesian plot)	12
Figure 15.	Far field radiation pattern plotted on X-Y plane	13
Figure 16.	Normalized radiation pattern on X-Y plan (polar plot)	14
Figure 17.	Normalized radiation pattern on X-Y plan (Cartesian plot)	14
Figure 18.	Far field radiation pattern plotted on X-Z plane	15
Figure 19.	Normalized radiation pattern on X-Z plan (polar plot)	16
Figure 20.	Normalized radiation pattern on X-Z plan (Cartesian plot)	16

IMPORTANT NOTICE – PLEASE READ CAREFULLY

STMicroelectronics NV and its subsidiaries (“ST”) reserve the right to make changes, corrections, enhancements, modifications, and improvements to ST products and/or to this document at any time without notice. Purchasers should obtain the latest relevant information on ST products before placing orders. ST products are sold pursuant to ST’s terms and conditions of sale in place at the time of order acknowledgement.

Purchasers are solely responsible for the choice, selection, and use of ST products and ST assumes no liability for application assistance or the design of Purchasers’ products.

No license, express or implied, to any intellectual property right is granted by ST herein.

Resale of ST products with provisions different from the information set forth herein shall void any warranty granted by ST for such product.

ST and the ST logo are trademarks of ST. For additional information about ST trademarks, please refer to www.st.com/trademarks. All other product or service names are the property of their respective owners.

Information in this document supersedes and replaces information previously supplied in any prior versions of this document.

© 2019 STMicroelectronics – All rights reserved