

FCC Test Firm Designation Number: FR0014
ISED Wireless Device Testing Laboratory CAB Number: FR0004

Matériel testé :
Equipment under test:

ST / MB1803B-01
(Trademark / Marketing name or product reference)

Demandeur de certification : **STMicroelectronics (Rousset) SAS**
Applicant for certification: 190 Avenue Celestin Coq
13106 – ROUSSET – France

Client : **STMicroelectronics**
Customer: 12 Rue Jules Horowitz
38000 – Grenoble – France

Numéro d'affaire : 10035
Work number :

Référence de la proposition : 112023-26544
Proposal number:

Date de l'essai : Du 30 Novembre au 13 Decembre 2023
Date of test: November 30th to December 13th,2023

Objectif des essais : EMC qualification accordingly to following standards:
Test purpose: - CFR 47, FCC Part 15, Subpart C
(Chapter 15.247 - Operation within the bands 902–928 MHz, 2400–2483.5 MHz, and 5725–5850 MHz)s
- Industry Canada RSS-247, Issue 3
(Digital Transmission Systems Operating in the Bands 902–928 MHz)
Measurement standards:
ANSI C63.10 (2013)

Lieu du test: SMEE, 385 Rue René Rambaud
Test location: 38500 VOIRON - France

Test réalisé par : Chemseddine KERMICHE
Test realized by:

Conclusion : L'équipement satisfait aux prescriptions et essais des normes citées en référence.
Conclusion: The appliance complies with requirements and tests of above mentioned standards.

Ed.	Date	Modifications / Pages	Written by: Visa	Approved by: Visa
1	February 29, 2024	Initial Edition	Chemseddine KERMICHE Test operator 	Laurent CHAPUS Technical Manager

La copie de ce document n'est permise que sous sa forme intégrale. Ce document est le résultat d'essais effectués sur un échantillon. Il ne préjuge pas de la conformité de l'ensemble des produits fabriqués à l'objet essayé. Pour la déclaration de conformité de l'équipement, il n'est pas tenu compte de l'incertitude de mesure. Cette nouvelle édition de ce rapport annule et remplace l'édition précédente. Les modifications apportées à une nouvelle édition de ce rapport sont signalées par un trait vertical à gauche de la page. L'utilisation de la marque d'accréditation COFRAC est interdite.
This document shall not be reproduced, except in full. This document contains results related only to the item tested. It does not imply the conformity of the whole production to the item tested. For the declaration of conformity of the equipment, the measurement uncertainty is not taken into account. This new edition of this report cancels and replaces the previous edition. Changes made to a new edition of this report are indicated by a vertical line to the left of the page. The use of the COFRAC accreditation mark is prohibited.



Accréditation
N° 1-6356
Portée disponible sur :
Scope available on :
www.cofrac.fr

COORDONNEES

SMEE
385, Rue René Rambaud, ZA Le Parvis 2
38500 VOIRON - France

TEL : 04 76 65 76 50
FAX : 04 76 66 18 30

SAS au capital de 50 000 € / RC Grenoble B534 796 453 / SIRET 534 796 453 00015 / code APE 7490B / n° TVA : FR 59 534 796 453

Contents

1. NORMATIVES REFERENCES.....	3
2. TEST SYNTHESIS	4
3. EQUIPMENT UNDER TEST (EUT)	5
4. TEST CONDITIONS	5
5. MODIFICATIONS OF THE EUT	6
6. SPECIAL ACCESSORY	6
7. MEASUREMENT UNCERTAINTY	6
8. FIELD STRENGTH CALCULATION	6
9. TEST SETUP DIAGRAM.....	7
10. CONDUCTED EMISSION MEASUREMENT (150 KHZ-30MHZ)	9
11. DTS BANDWIDTH.....	12
12. MAXIMUM PEAK OUTPUT POWER	15
13. MAXIMUM POWER SPECTRAL DENSITY LEVEL IN THE FUNDAMENTAL EMISSION	18
14. UNWANTED EMISSIONS IN NON-RESTRICTED FREQUENCY BANDS (RADIATED EMISSIONS)	21
15. UNWANTED EMISSIONS IN RESTRICTED FREQUENCY BANDS	24
16. OCCUPIED BANDWIDTH (99%)	30
17. TEST EQUIPMENT LIST	33

1. Normatives References

FCC qualification according to:		
Standards	Applied	Title
ANSI C63.10 (2013)	X	American National Standard for Testing Unlicensed Wireless Devices
CFR47, Part 15 (December 2023)	X	Telecommunication – Federal Communication Commission – Radio frequency devices, Sections 15.207 / 15.209 / 15.247

ISED qualification according to:		
Standards	Applied	Title
RSS-Gen (Issue 5/2018, amendments 2019 and 2021)	X	General Requirements and Information for the Certification of Radio Apparatus
RSS-247 (Issue 3/2023)	X	Digital Transmission Systems (DTSs), Frequency Hopping Systems (FHSs) and Licence-Exempt Local Area Network (LE-LAN) Devices

Note: Following guidance are used

- DTS Measurement Guidance 558074 D01 v05r02
- Determining ERP and EIRP Guidance 412172 D01 v01r01

Deviation from standard: None.

2. Test synthesis

TEST	Paragraph number FCC Part 15 / ISED ICES & RSS	Spec. FCC Part 15 / ISED ICES & RSS	RESULTS (comments)
Conducted emissions test	15.207 (a) RSS-Gen § 8.8	Table 15.107 (a) / 15.207 (a) Table 4 / RSS-Gen	PASS
6dB Bandwidth	15.247 (a) (2) RSS-247 § 5.2 (a)	At least 500kHz	PASS
Maximum Peak Output Power	15.247 (b) (3) & (4) RSS-247 § 5.4 (d)	1W max / 30dBm (Conducted) 4W max / 36dBm (EIRP)	PASS
Maximum Power Spectral Density	15.247 (e) RSS-247 § 5.2 (b)	8dBm in a 3kHz band segment	PASS
Unwanted emissions into Non Restricted Frequency Bands	15.247 (d) / RSS-247 § 5.5	-20dBc in any 100kHz outside frequency band.	PASS
Unwanted emissions into Restricted Frequency Bands	15.209 (a) / 15.247 (d) / 15.205 (a) RSS-GEN §8.9, § 8.10 / RSS-247 § 5.5	<u>Measure at 300m</u> 9-490kHz: 2400µV/m/F(kHz) 6.370µA/m/F (kHz) <u>Measure at 30m</u> 0.490-1.705: 24000µV/m/F(kHz) 63.70µA/m/F (kHz) 1.705-30MHz: 30µV/m 0.08µA/m <u>Measure at 3m</u> 30MHz-88MHz : 40 dBµV/m 88MHz-216MHz : 43.5 dBµV/m 216MHz-960MHz : 46.0 dBµV/m Above 960MHz : 54.0 dBµV/m	PASS
Occupied Bandwidth	RSS-GEN § 6.7	BW at 99%	PASS
Antenna requirement	FCC 15.203 RSS-GEN § 6.8		PASS

- General conclusion:**

Measures and tests performed on the sample of the product *ST / MB1803B-01*, in configuration and description presented in this test report, show compliance with standards FCC CFR 47, PART 15, Subpart C and ISED RSS-Gen & RSS-247.

3. Equipment Under Test (EUT)

**Nom /
Identification**

ST / MB1803B-01
(Trademark / Marketing name or product reference)

MB1803-WBA55CGA-B01
SN: D2334100082

FCC ID: YCP-MB180300
IC: 8976A-MB180300
Model / HVIN: MB1803B-01
Product name / PMN: MB1803B
FVIN: V1.2.0
Modular approval: Yes

**Alimentation /
Power supply** 5V DC from Laptop USB-Port. (USB port)

**Auxiliaires /
Auxiliaries** Laptop ASUS, model ASUS VIVABOOK for equipment programming only.

**Entrées-Sorties /
Input / Output**

	Câbles pour essai / Cables for test	Blindé / Shielded	Prévu pour >3m / Intended for >3m
USB-Type C Cable (Power + STLink)	1.0m	Yes	No

**Mode de fonctionnement /
Running mode**

The BLE module MB1803B is plug onto a mini-.board MB1801D.
The device (MB1801D+MB1803B) is powered by DC 5V, the device is connected to a PC with an USB cable.
The tested sample is able to:
- Transmit a carrier frequency on low, middle and high channels (Bluetooth Low Energy).

**Programme de test /
Test program /**

STM32CubeMonitor-RF Version 2.9.0-S4602

**Fréquence max interne EST /
Max internal EUT frequency**

2.480GHz for RF data transmission.

**Information sur l'équipement /
Equipment information**

Declaration of the applicant:
- Frequency band: 2400 to 2483.5 MHz (Tx & Rx, Wideband Data Transmission systems)
- BLE Power Setting: Power is set at 10dBm
- Duty cycle: 85%
- Modulation: Bluetooth Low Energy GFSK (1Mbps, 2Mbps) for DTS
- BLE version 5.3
- Antenna type: Printed PCB (Max antenna gain 1.95dBi)
- Powered by 5V DC from external power supply
- Equipment intended for use as a mobile device
- Equipment designed for continuous operation

**Dimensions de l'EST /
Dimensions of EUT**

48mm x 43x 8 (PCB)

All Information above is declared by the customer / applicant and are under his responsibility.

4. Test conditions

Power supply voltage:
Equipment under test: 5V DC from Laptop USB-Port
Auxiliaries: 120V/60Hz

5. Modifications of the EUT

None.

6. Special accessory

None.

7. Measurement Uncertainty

Test Description	Expanded uncertainty
Conducted emissions test (150k-30MHz, AC mains)	± 3.5dB
Radiated emission test (9kHz-30MHz, electric field)	± 4.0dB
Radiated emission test (30-200MHz, SAC 3m)	± 5.6dB
Radiated emission test (200-1000MHz, SAC 3m)	± 5.3dB
Radiated emission test (1-18GHz, FAC 3m)	± 5.6dB
Radiated emission test (18-40GHz, FAC 3m)	± 5.6dB
Conducted RF output power at antenna port	± 1.6dB
Radiated RF output power (Peak, Power density)	± 5.6dB
DTS Bandwidth, 99% OBW	±4%
Temperature	± 1°C
Time and duty cycle calculation	±1%
AC and DC voltage	±1%

Note: Expanded uncertainty at 95% confidence (k=2)

8. Field Strength Calculation

The field strength (level) is calculated by adding the Antenna Factor and Cable Factor, and subtracting the Amplifier Gain (if any) from the measured reading. The basic equation is as follow:

$$FS = RA + AF + CF - AG$$

Where FS = Field Strength (Level)

RA = Receiver Amplitude (Meter Reading)

AF = Antenna Factor

CF = Cable Factor

AG = Amplifier Gain

Margin value = Emission level – Limit value

Example:

RA: 14.0dB μ V / AF: 16.5 dBm⁻¹ / CF: 3.5dB / AG: 15dB

→ Total factor: 5dBm⁻¹

→ Field level: 19.0dB μ V/m (-21.0dB for margin if limit is 40dB μ V/m)

9. Test Setup Diagram

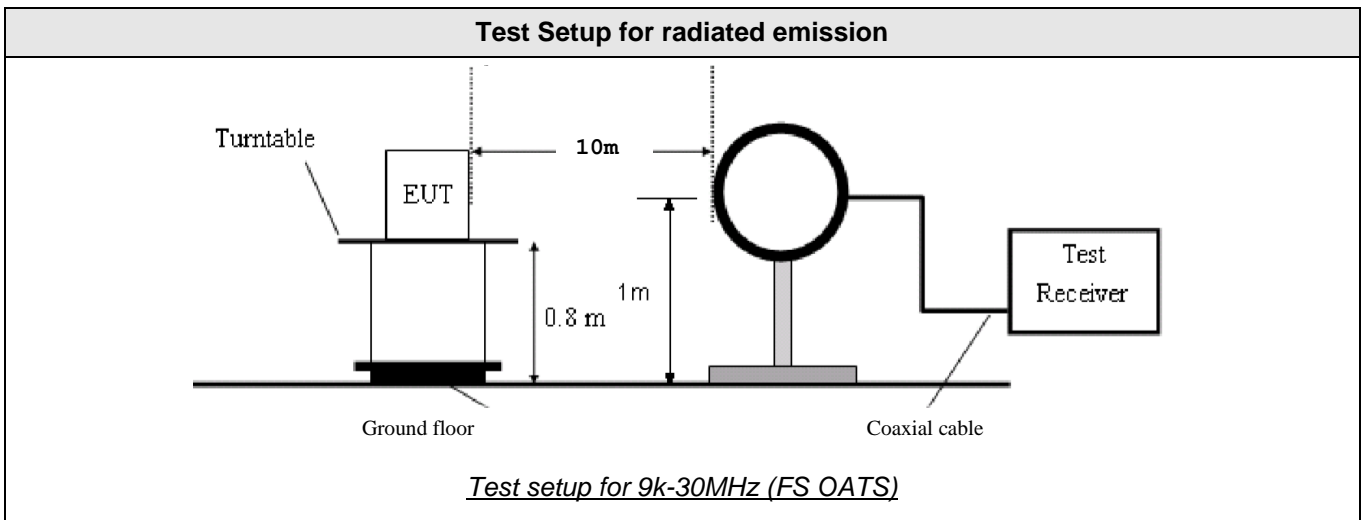
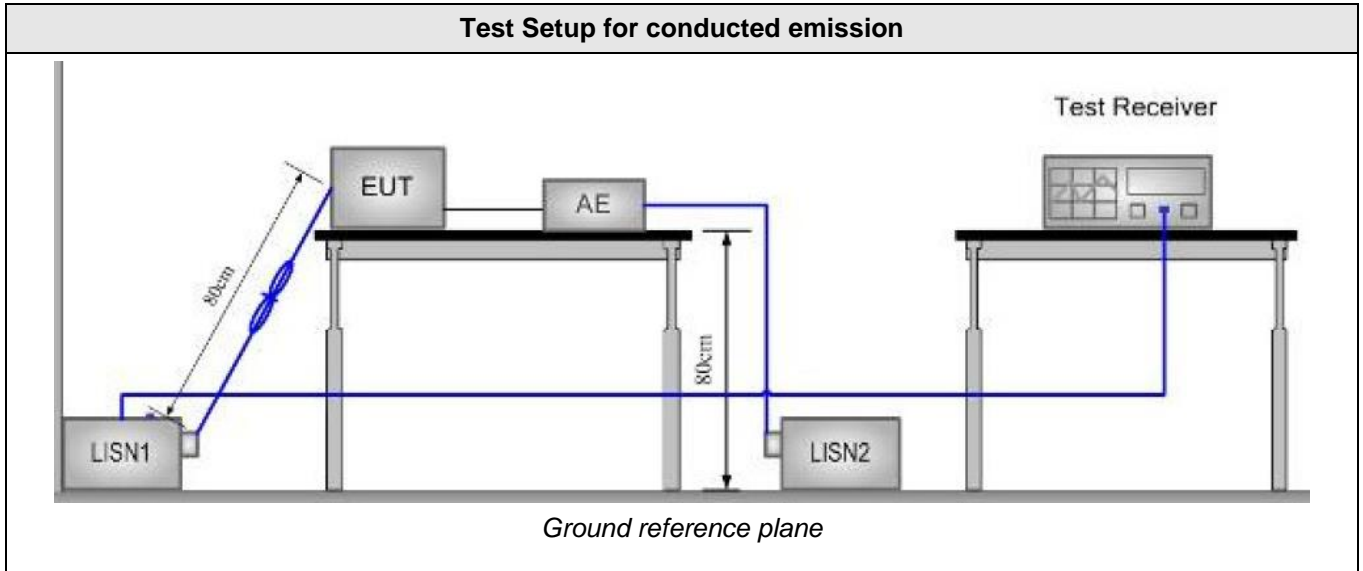

Test Setup for radiated emission

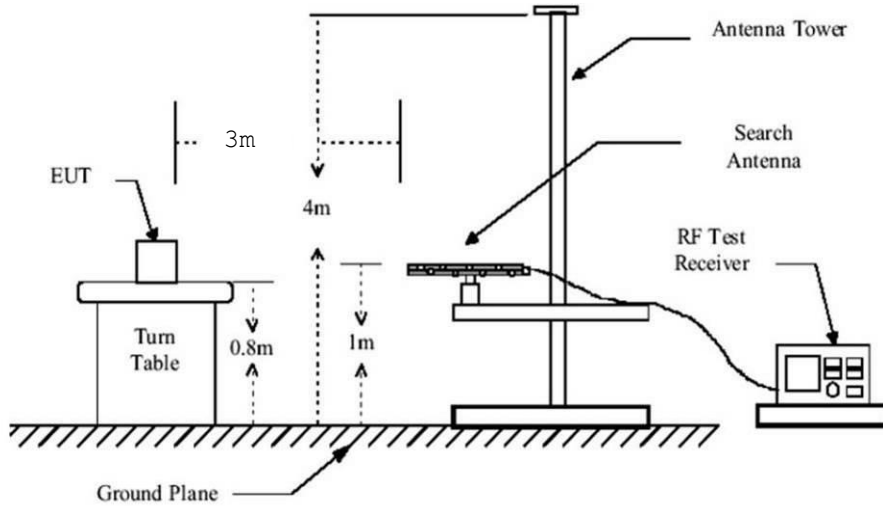

Test setup for 30-1000MHz (SAC 3m)

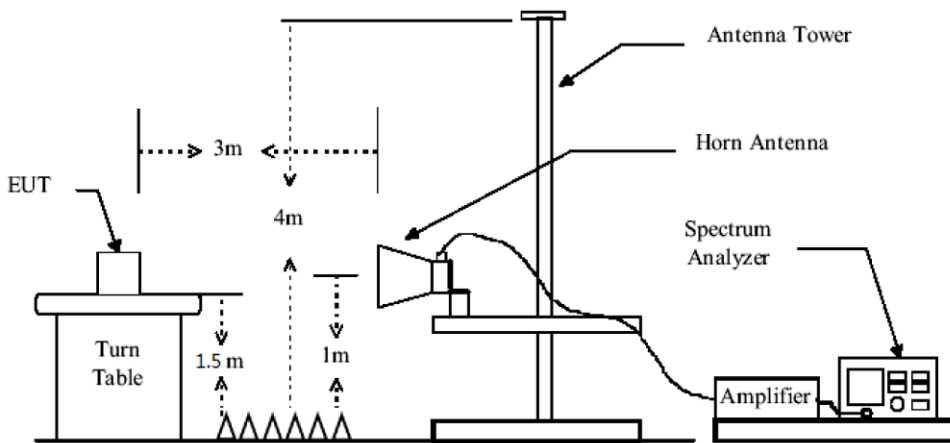

Test setup for 1-25GHz (SAC 3m, tilt antenna mast used)

Test Setup for conducted antenna port measurement

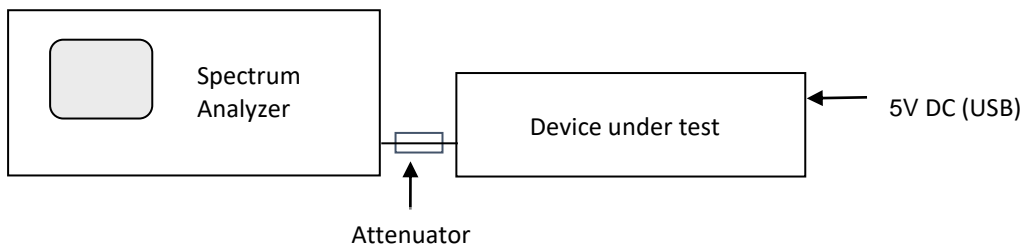

10. Conducted Emission Measurement (150 kHz-30MHz)

TEST: Limits for conducted disturbance 150kHz – 30MHz				Verdict
<p><u>Method:</u> The LISN is placed 0,8 m from the boundary of the unit under test and bonded to a ground reference plane. This distance was between the closest points of the AMN and the EUT. All other units of the EUT and associated equipment were at least 0,8 m from the AMN. All power was connected to the system through Artificial Mains Network (AMN). Conducted voltage measurements on lines were made at the output of the LISN. The EUT is 80cm above the ground reference plane and 40cm from the vertical ground plane. The AC power cable is 1m length.</p>				Pass
Laboratory Parameters:		Required prior to the test		During the test
Ambient Temperature		17 - 27 °C		21°C ± 2
Relative Humidity		25 - 65 %		48% ± 5
Fully configured sample scanned over the following frequency range		Frequency range on each side of line		Measurement Point
		150kHz to 30MHz		AC input port (110V/60Hz)
Limits				
Frequency (MHz)	Limit dB (µV)			
	Quasi-Peak	Result	Average	Result
0.15 – 0.50	66 \ 56	PASS	56 \ 46	PASS
0.50 - 5	56	PASS	46	PASS
5 – 30	60	PASS	50	PASS
Supplementary information: Test location: SMEE Test date: December 13 th , 2023 by C KERMICHE. Power supply voltage: 5V DC from USB-Port, powered with 120V 60Hz.				

Tabulated Results for Mains Terminal Disturbance Voltage on AC port

FREQ (MHz)	Meas. PK (dBμV)	Mes. QP (dBμV)	LIMIT QP (dBμV)	Margin QP (dB)	Mes. AV (dBμV)	LIMIT AV (dBμV)	Margin AV (dB)	Line
0.156122	52.73	48.57	65.57	-17.00	30.10	55.57	-25.47	L1
0.160043	51.37	46.71	65.36	-18.65	27.87	55.36	-27.50	L1
0.283685	39.33	33.31	60.76	-27.45	19.73	50.76	-31.03	L1
9.700781	41.20	36.73	60.00	-23.27	29.59	50.00	-20.41	L1
16.341742	46.20	44.28	60.00	-15.72	38.15	50.00	-11.85	L1
22.06789	24.62	19.18	60.00	-40.82	13.24	50.00	-36.76	L1
0.150651	52.17	48.32	65.95	-17.63	29.52	55.96	-26.44	N
0.192043	45.16	39.41	63.86	-24.46	21.84	53.86	-32.03	N
0.393323	35.32	30.88	57.98	-27.10	21.81	47.98	-26.17	N
3.768104	32.48	28.09	56.00	-27.91	14.53	46.00	-31.47	N
9.842003	40.03	36.12	60.00	-23.88	29.07	50.00	-20.93	N
16.341731	44.41	42.07	60.00	-17.93	35.98	50.00	-14.02	N
RBW:	9kHz							
Voltage:	120V/60Hz							
Limit:	FCC Part 15.209 a) / RSS-Gen: Issue 5, §8.8 Table 4							
Final measurement detector:	Quasi-Peak and CISPR Average (AV)							
RESULT:	PASS							
Measured value calculation:	<p>The measured value (level) is calculated by adding the Cable Factor, the Transient suppressor attenuation and LISN attenuation from the receiver amplitude reading. The basic equation is as follow:</p> $\text{Meas.} = \text{RA} + \text{CF} + \text{ATT}_{\text{TRAN}} + \text{ATT}_{\text{LISN}}$ <p>Where Meas. = Level (dBμV) RA = Receiver Amplitude CF = Cable Factor ATT_{TRAN} = Transient suppressor attenuation ATT_{LISN} = LISN attenuation</p> <p>Margin value = Emission level – Limit value (A negative margin shows compliance to limit)</p>							

Graphical representation of Conducted Disturbance Measurement (Peak and Average detection) AC port, Line L1

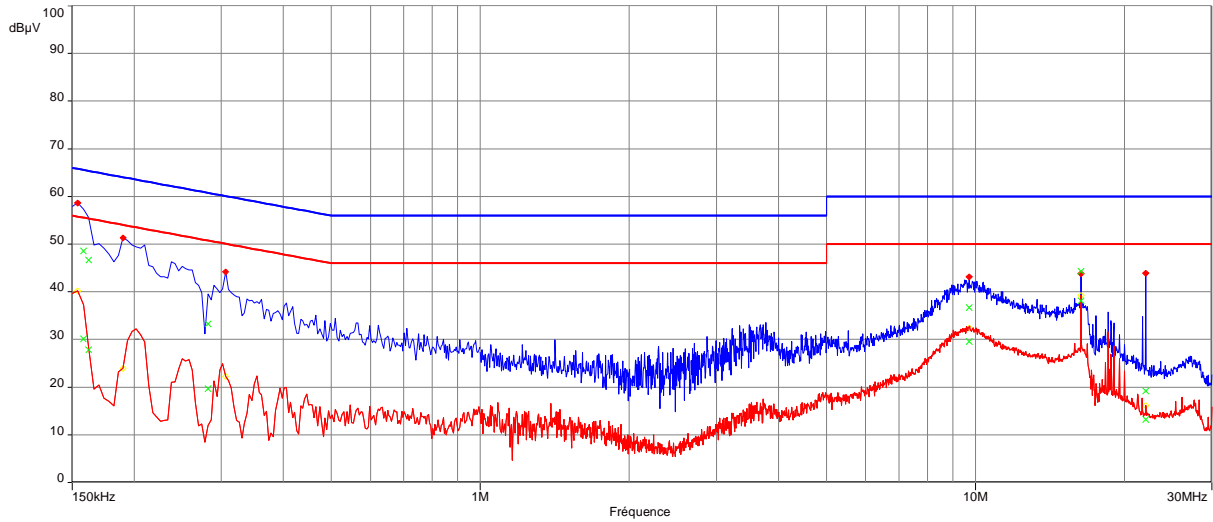

Note : Same result for all transmit modes on all channels.

Peak

Average

Graphical representation of Conducted Disturbance Measurement (Peak and Average detection) AC port, Line Neutral

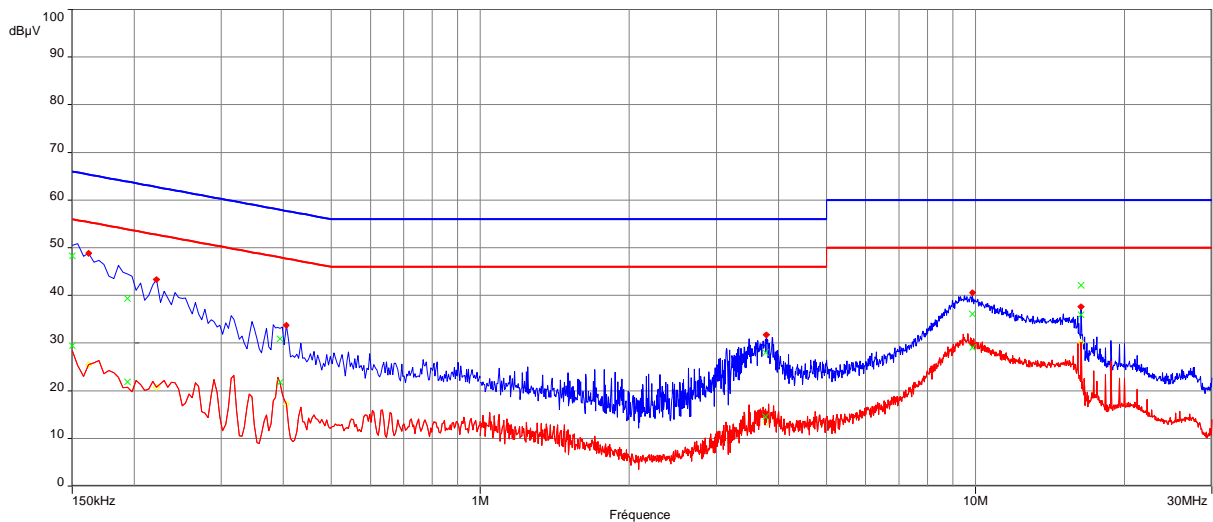

Note : Same result for all transmit modes on all channels.

Peak

Average

11. DTS Bandwidth

TEST: DTS Bandwidth		Verdict
<p>Method: The setup is in an anechoic chamber. The spectrum analyzer is connected to the measuring antenna. A radiated measurement is performed. The RBW is 100kHz, with VBW ≥ 3 x RBW. The SPAN is wide enough to capture all products of the modulation process. A MaxHold Peak detector is used. Automatic function of the spectrum analyser is used. The tested equipment is set to transmit operation with modulation on low, mid and high channels.</p>		Pass
Laboratory Parameters:	Required prior to the test	During the test
Ambient Temperature	20 to 30 °C	21°C ± 2
Relative Humidity	25 to 70 %	48% ± 5
Limits – FCC Part 15.247 (a) / RSS-247 §5.2 (a)		
Frequency (MHz)	Level for Bandwidth	Limit
2402.0	6dB below the maximum output power	At least 500kHz
2440.0		
2480.0		
<p>Supplementary information: Test location: SMEE Test date: December 1st, 2023 by C KERMICHE. Power supply voltage: 5V DC from USB-Port.</p>		

Tabulated Results for Occupied Bandwidth		
Frequency (MHz)	6dB Bandwidth (kHz)	Result
BLE: 1MBps		
2402.0	671.0	Pass
2440.0	665.0	Pass
2480.0	670.0	Pass
BLE: 2MBps		
2402.0	1006.0	Pass
2440.0	1142.0	Pass
2480.0	1142.0	Pass

Graphical representation of 6dB Bandwidth / BLE: 1Mbps

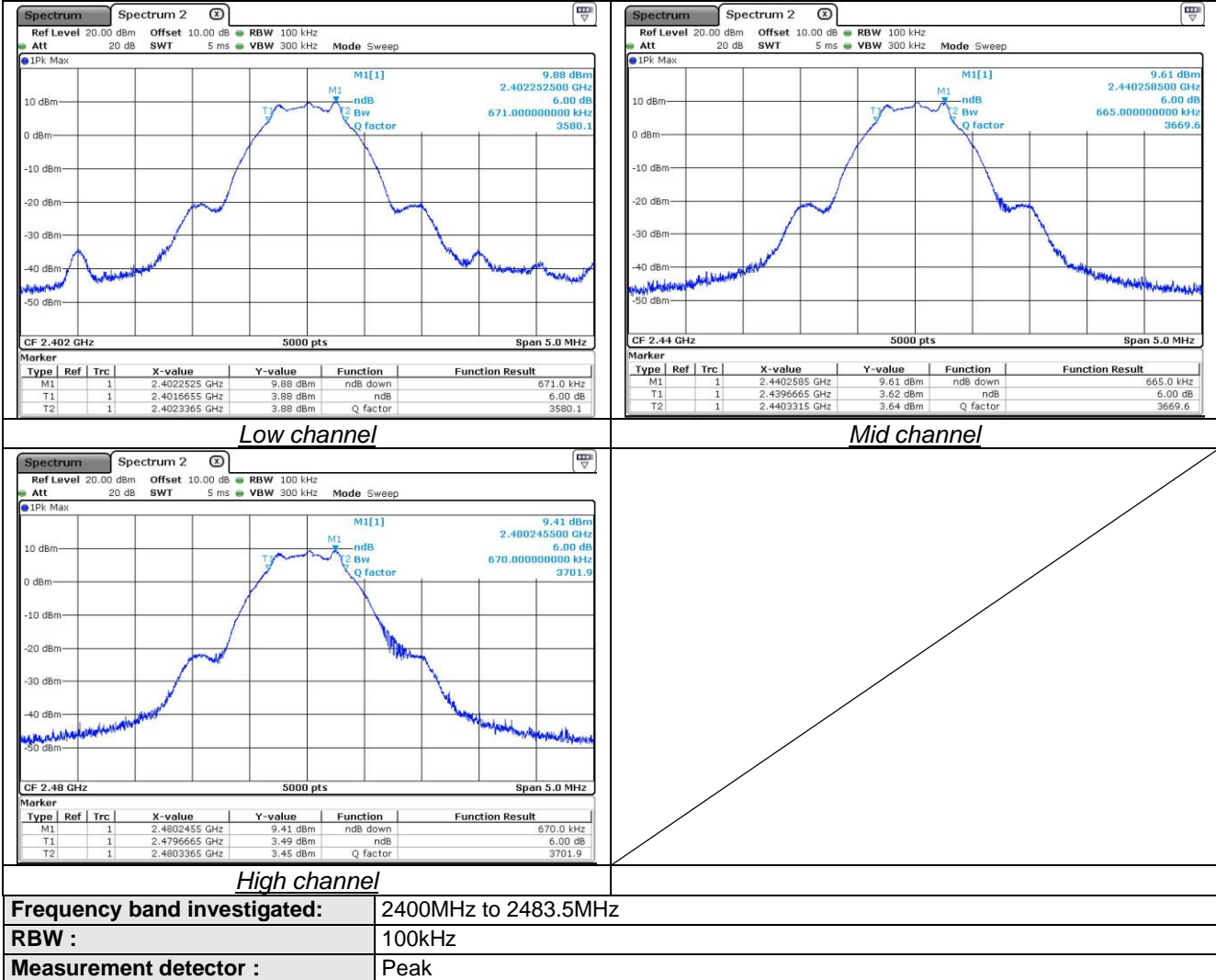

Graphical representation of 6dB Bandwidth / BLE: 2Mbps

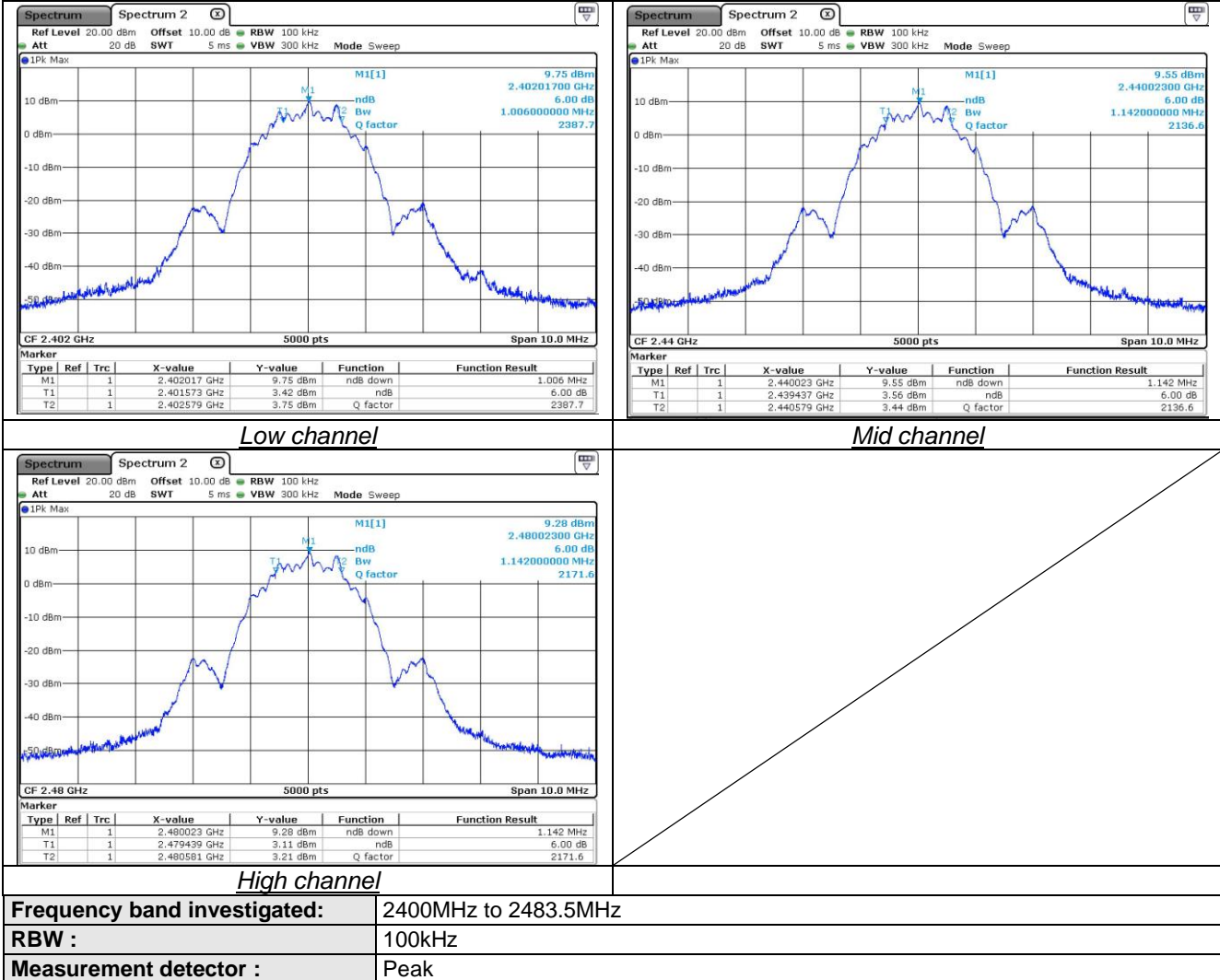

12. Maximum Peak Output power

TEST: Maximum peak conducted output power		Verdict
<p>Method: A radiated measurement is performed. The RBW is wide enough to capture the maximum amplitude level. The SPAN is wide enough to capture all products of the modulation process. A MaxHold Peak detector is used. Radiated field strength of RF Output Power is measured at 3m in a Semi Anechoic Chamber (SAC) that complies with ANSI C63.10 / ANSI C63.4. Maximum field strength (Peak) is performed by rotating the EUT 360° and adjusting the receive antenna height from 1 to 4 m. All frequencies were investigated in both horizontal and vertical antenna polarity The tested equipment is set to transmit operation with modulation on low, mid and high channels.</p>		Pass
Laboratory Parameters:	Required prior to the test	During the test
Ambient Temperature	20 to 30 °C	21°C ± 2
Relative Humidity	25 to 70 %	48% ± 5
Limits – FCC Part 15.247 (b) / RSS-247 §5.4 (d)		
Frequency (MHz)	Limits (dBµV/m)	
	Level / Detector	Results
2400 to 2483.5	36 dBm / Pk / 3m (Radiated)	Pass
2400 to 2483.5	30 dBm / Pk (Conducted)	Pass
Supplementary information: Test location: SMEE Test date: December 1 st , 2023 by C KERMICHE. Power supply voltage: 5V DC from USB-Port.		

Tabulated Results for Maximum peak output power (Conducted & Radiated measurement)						
FREQ	Conducted power	Antenna Gain	Radiated power E.I.R.P	Conducted Limit	Radiated Limit	Result
(MHz)	(dBm)	(dBi)	(dBm)	(dBm)	(dBm)	
1Mbps						
2402	10.0	1.95	11.95	30.0	36.0	Pass
2440	9.8	1.95	11.75	30.0	36.0	Pass
2480	9.5	1.95	11.45	30.0	36.0	Pass
2Mbps						
2402	10.0	1.95	11.95	30.0	36.0	Pass
2440	9.8	1.95	11.75	30.0	36.0	Pass
2480	9.5	1.95	11.45	30.0	36.0	Pass
RBW:		1MHz				
Measurement distance:		3m				
Limit:		FCC Part 15.247 / RSS-247				
Final measurement detector:		Peak				
RESULT:		PASS				
Note:		EIRP is calculated using the following equation: $\text{EIRP} = \text{Conducted power (dBm)} + \text{Antenna Gain (dBi)}$ Where Antenna gain = 1.95 dBi (declared by the manufacturer).				

Graphical representation for Maximum Peak Output power (1Mbps)

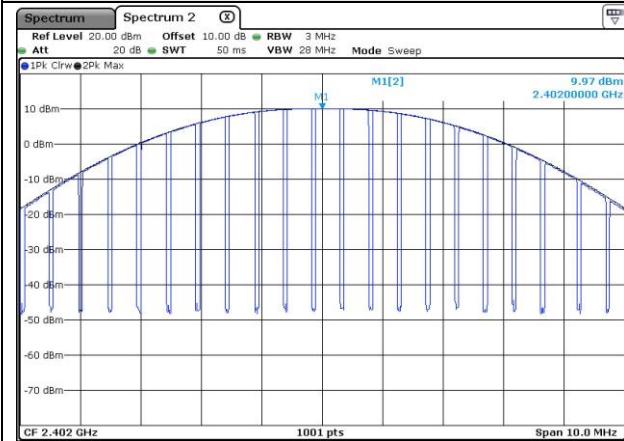

Low channel

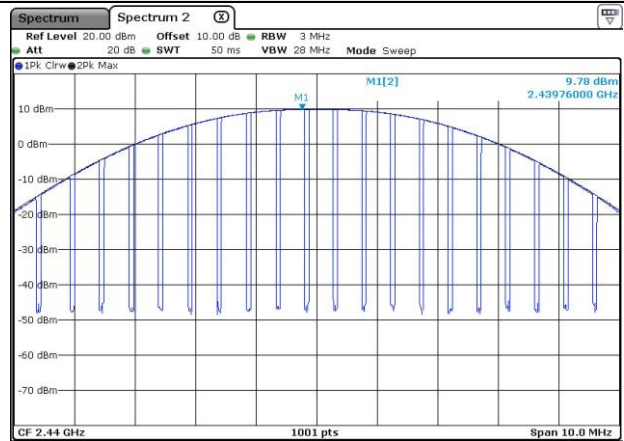

Mid channel

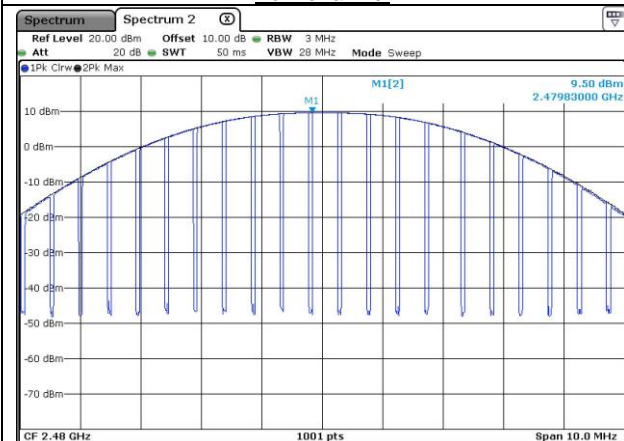

High channel

Measurement:	Conducted measurement
Limit:	FCC Part 15.247 / RSS-247
RBW:	3MHz (RBW \geq DTS bandwidth)
VBW:	28MHz (VBW \geq [3 \times RBW])
Span:	10MHz (Set span \geq [3 \times RBW])

Graphical representation for Maximum Peak Output power (2Mbps)

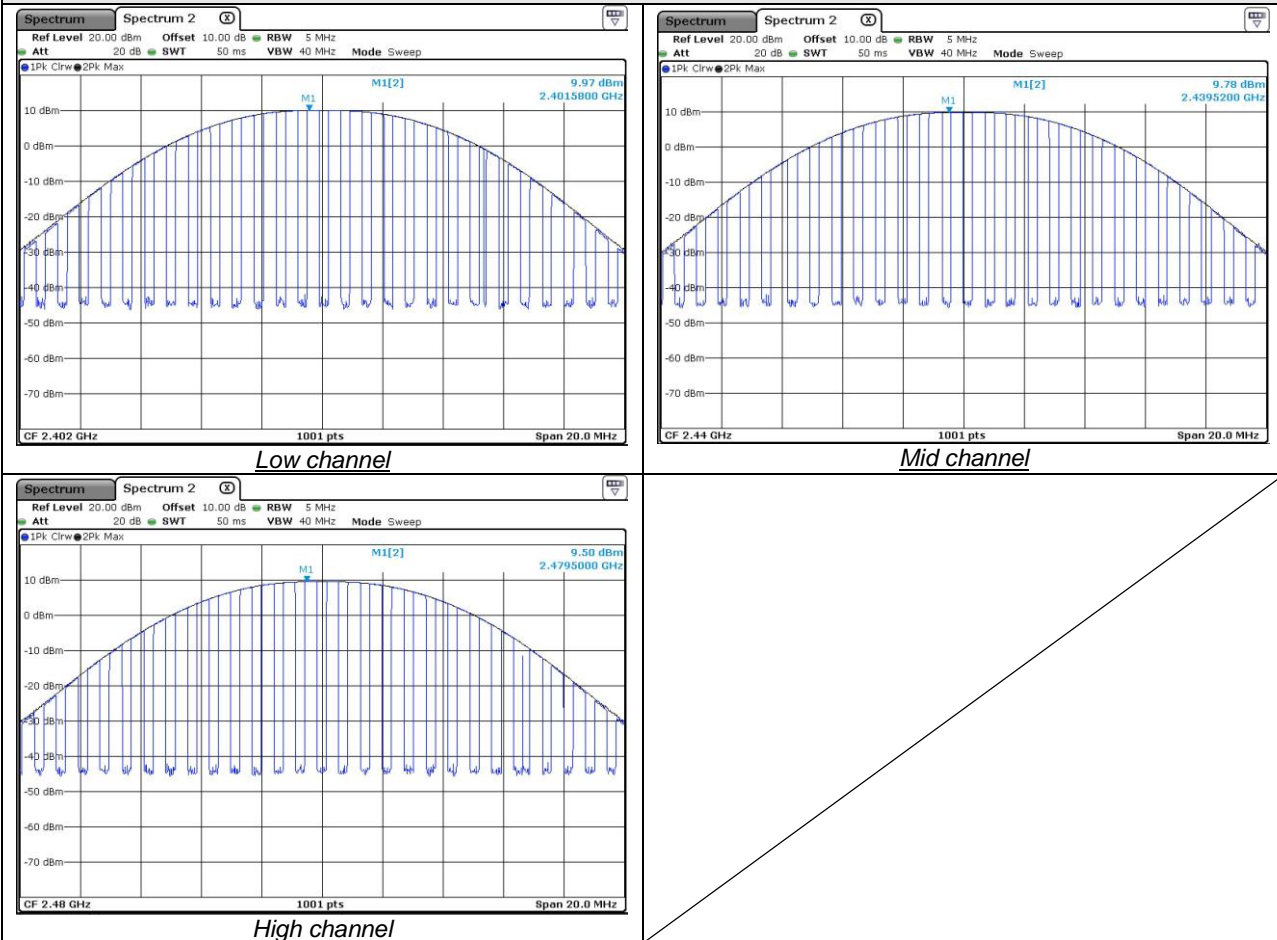

Measurement:	Conducted measurement
Limit:	FCC Part 15.247 / RSS-247
RBW:	5MHz (RBW \geq DTS bandwidth)
VBW:	40MHz (VBW \geq [3 \times RBW])
Span:	20MHz (Set span \geq [3 \times RBW])

13. Maximum Power Spectral Density Level in the fundamental emission

TEST: Maximum Peak Power Spectral Density		Verdict
<p><u>Method:</u> A radiated measurement is performed. The RBW is set at 3kHz. The SPAN is wide enough to capture all products of the modulation process. A MaxHold Peak detector is used. Radiated field strength of RF Output Power is measured at 3m in a Semi Anechoic Chamber (SAC) that complies with ANSI C63.10 / ANSI C63.4. Maximum field strength (Peak) is performed by rotating the EUT 360° and adjusting the receive antenna height from 1 to 4 m. All frequencies were investigated in both horizontal and vertical antenna polarity The tested equipment is set to transmit operation with modulation on low, mid and high channels.</p>		Pass
Laboratory Parameters:	Required prior to the test	During the test
Ambient Temperature	20 to 30 °C	21°C ± 2
Relative Humidity	25 to 70 %	48% ± 5
Limits – FCC Part 15.247 (e) / RSS-247 §5.2 (b)		
Frequency (MHz)	Level (Detector)	Limit
2402 / 2440 / 2480	8 dBm/3kHz (Pk)	Pass
Supplementary information:		
Test location: SMEE		
Test date: December 1 st , 2023 by C KERMICHE.		
Power supply voltage: 5V DC from USB-Port.		

Tabulated Results for Maximum Conducted Power Spectral Density			
Frequency (MHz)	PSD (dBm/3kHz)	Limit	Result
BLE: 1Mbps			
2402.0	-5.8	8dBm/3kHz	Pass
2441.0	-6.1	8dBm/3kHz	Pass
2480.0	-6.5	8dBm/3kHz	Pass
BLE: 2Mbps			
2402.0	-7.6	8dBm/3kHz	Pass
2441.0	-7.7	8dBm/3kHz	Pass
2480.0	-7.9	8dBm/3kHz	Pass
RBW:	3kHz		
Limit:	FCC Part 15.247 / RSS-247		
Final measurement detector:	Peak		
RESULT:	PASS		

Graphical representation for Maximum Power Spectral Density / BLE: 1Mbps

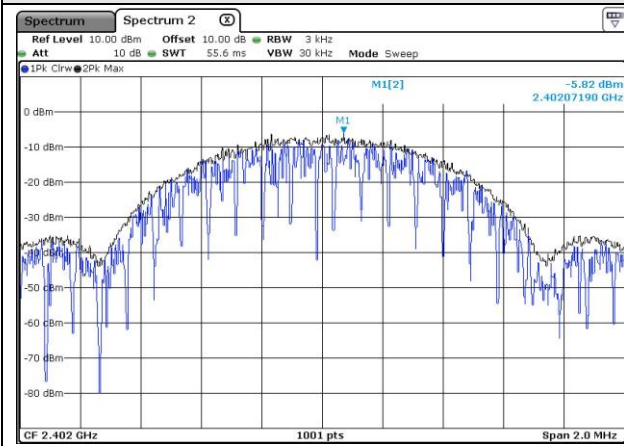

Low channel

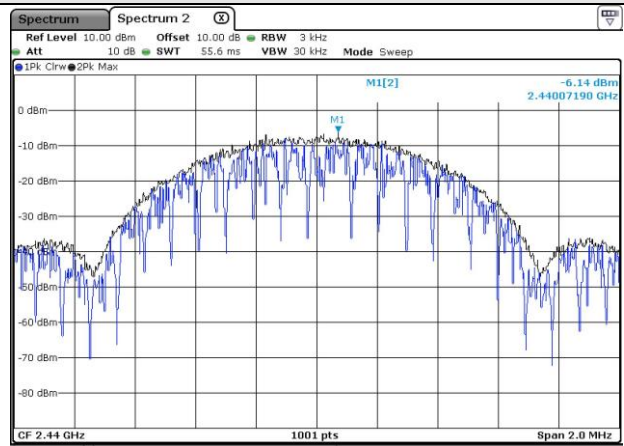

Mid channel

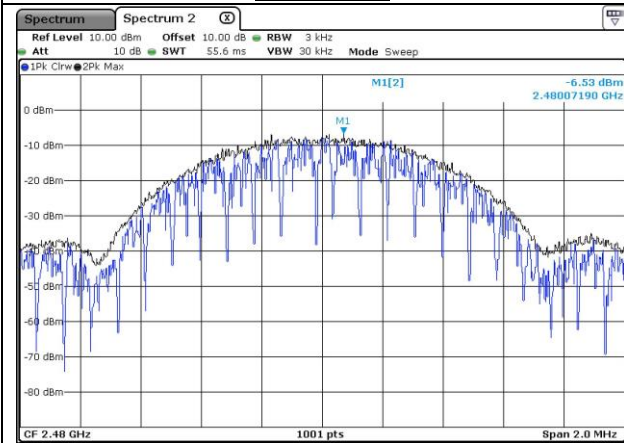

High channel

Measurement:	Conducted measurement
RBW:	3kHz
Limit:	FCC Part 15.247 / RSS-247
RESULT:	PASS

Graphical representation for Maximum Power Spectral Density / BLE: 2Mbps

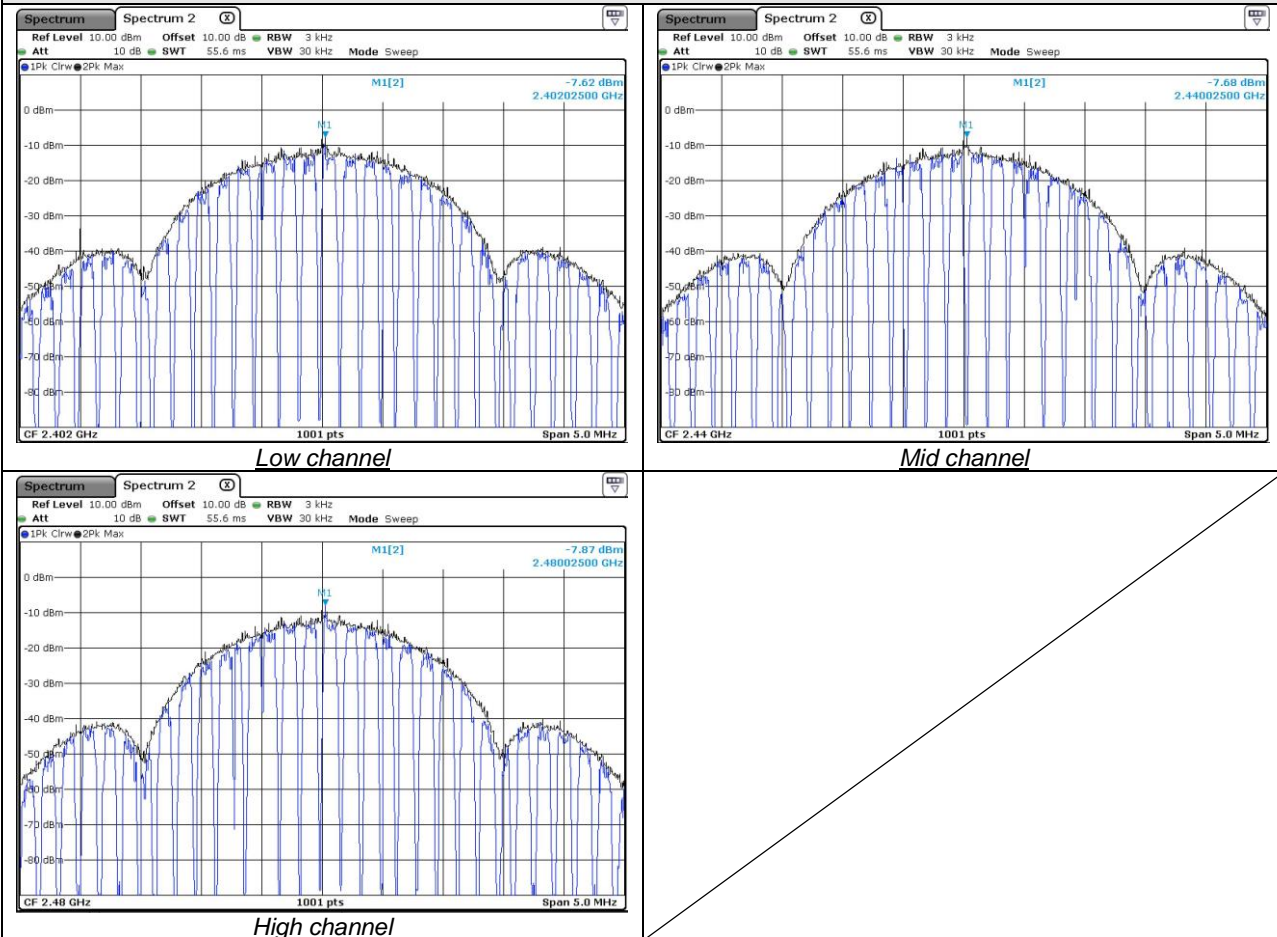

Measurement:	Conducted measurement
RBW:	3kHz
Limit:	FCC Part 15.247 / RSS-247
RESULT:	PASS

14. Unwanted emissions in Non-Restricted Frequency bands (Radiated emissions)

TEST: Unwanted emissions in Non-Restricted Frequency Bands			Verdict
<p>Method: Measurements were made in a 3-meter Semi Anechoic Room (SAR) up to 1GHz and in a 3-meter Full Anechoic environment (SAR with floor absorbers) above 1GHz. The Semi Anechoic Room complies with CISPR16-1-4 / ANSI C63.4 requirements. Preliminary (peak) measurements were performed at an antenna to EUT separation distance of 3 meters. The EUT was rotated 360° about its azimuth with the receive antenna located at various heights in horizontal and vertical polarities. The pre-characterization graphs are obtained in PEAK detection. Final measurements (Peak, Quasi-peak, Average) were then performed by rotating the EUT 360° and adjusting the receive antenna height from 1 to 4 m. All frequencies were investigated in both horizontal and vertical antenna polarity, where applicable.</p>			Pass
Laboratory Parameters:	Required prior to the test	During the test	
Ambient Temperature	20 to 30 °C	21°C ± 2	
Relative Humidity	25 to 70 %	48% ± 5	
Fully configured sample scanned over the following frequency range	Frequency range on each side of line	Measurement Point	
	30MHz – 25GHz	3m measurement distance	
Limits – FCC Part 15.247 (d) / RSS-247 § 5.5			
Frequency (MHz)	Limits (dBµV/m)		
	Detector / Analyser RBW	Limit	Results
30 to 25000	Pk / 100kHz	20dB below the maximum Peak level	Pass
Supplementary information: Test location: SMEE Test date: December 1 st , 2023 by C KERMICHE. Power supply voltage: 5V DC from USB-Port.			

Tabulated Results for Peak Output Power Reference level	
FREQ (MHz)	Field Strength 3m (dBµV/m)
2402.0	104.9 ⁽¹⁾
2440.0	104.8 ⁽¹⁾
2480.0	104.6 ⁽¹⁾
RBW:	100kHz
Measurement distance:	3m
Limit:	Ref. level only – For 15.247 (d) / RSS-247 § 5.5
Final measurement detector:	Peak
Note:	(1): Only for identification of limit in non-restricted band Limit is 84.6 dBµV/m Peak for out-of-band frequencies in Non-Restricted bands (with a 100kHz RBW on the spectrum analyzer).

Tabulated Results for Unwanted emissions in Non-Restricted bands (30M-25GHz)

FREQ (MHz)	Field Strength 3m (dB μ V/m)	Limit (dB μ V/m)	Margin (dB μ V/m)	Result (dB μ V/m)
14413.40201	55.2	84.6	-29.4	Pass
14641.51348	53.7	84.6	-30.9	Pass
RBW:	100kHz			
Measurement distance:	3m			
Limit:	FCC 15.247 / RSS-247			
Final measurement detector:	Peak			
RESULT:	PASS			
Note:	See band-edge measurement. See pre-scan graphs in chapter 15.			

Graphical representation of Band-edge compliance (LOW)

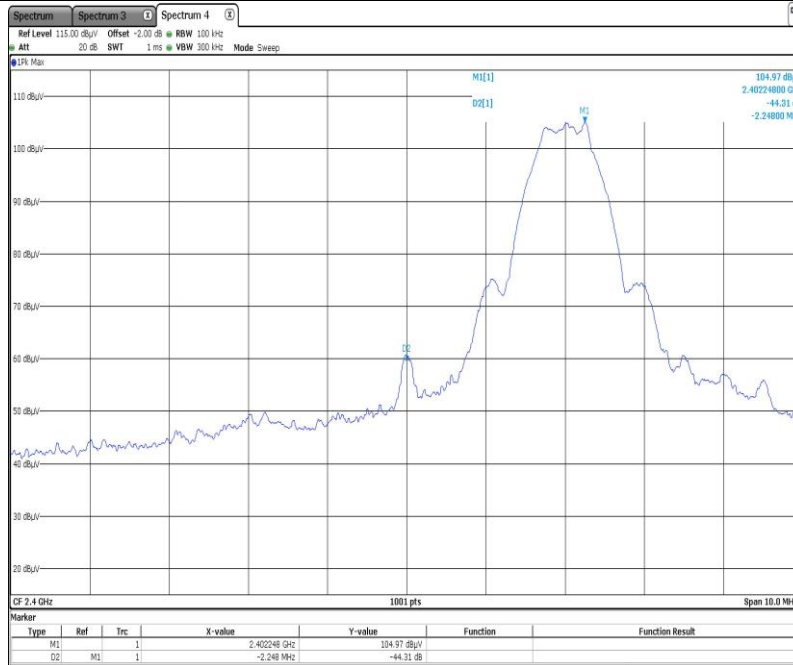

Low band edge compliance: BLE/1Mbps

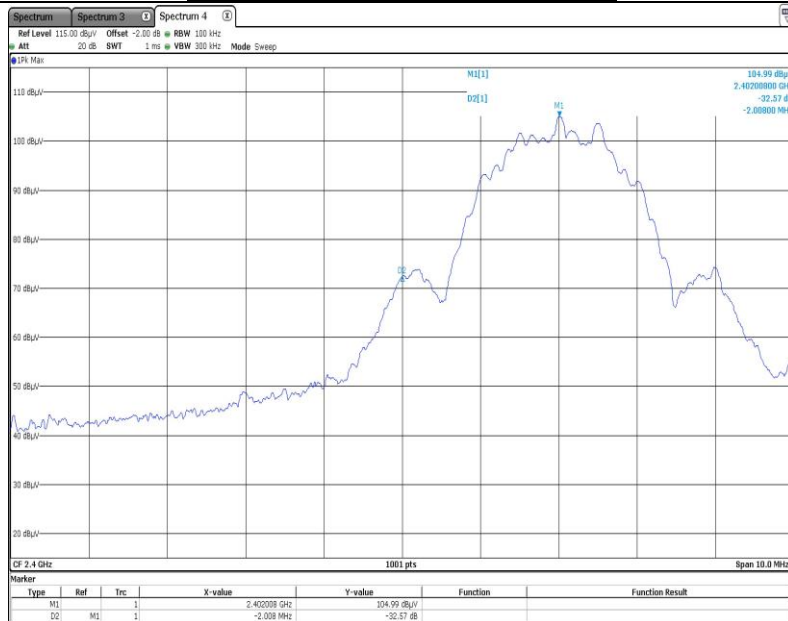

Low band edge compliance: BLE/2Mbps

RESULT: PASS.

Note: Radiated measurement.

FREQ (MHz)	Field Strength 3m (dBµV/m)	Limit (dBµV/m)	Margin (dBµV/m)	Result (dBµV/m)
BLE: 1Mbps				
2400.00	60.6	84.6	-24.0	Pass
BLE: 2Mbps2				
2400.00	72.3	84.6	-12.3	Pass

15. Unwanted emissions in Restricted Frequency bands

TEST: Unwanted emissions into Restricted Frequency Bands		Verdict													
<p>Method: Measurements were made in a 3-meter Semi Anechoic Room (SAR) for frequency 30MHz to 1GHz and in a 3-meter Full Anechoic environment (SAR with floor absorbers) above 1GHz. The Semi Anechoic Room complies with CISPR16-1-4 / ANSI C63.4 requirements. For frequency 9kHz to 30MHz, measurements are performed on a free-space open area test site at 10m distance.</p> <p>Preliminary (peak) measurements were performed at an antenna to EUT separation distance of 3 meter. The EUT was rotated 360° about its azimuth with the receive antenna located at various heights in horizontal and vertical polarities.</p> <p>Final measurements (Peak, Quasi-peak, Average) were then performed by rotating the EUT 360° and adjusting the receive antenna height from 1 to 4 m. All frequencies were investigated in both horizontal and vertical antenna polarity, where applicable.</p>		Pass													
Laboratory Parameters:	<table border="1"> <thead> <tr> <th>Required prior to the test</th> <th>During the test</th> </tr> </thead> <tbody> <tr> <td>Ambient Temperature</td> <td>20 to 30 °C</td> </tr> <tr> <td>Relative Humidity</td> <td>25 to 70 %</td> </tr> <tr> <td>Fully configured sample scanned over the following frequency range</td> <td> <table border="1"> <thead> <tr> <th>Frequency range on each side of line</th> <th>Measurement Point</th> </tr> </thead> <tbody> <tr> <td>9kHz – 30MHz</td> <td>10 m measurement distance</td> </tr> <tr> <td>30MHz – 25GHz</td> <td>3 m measurement distance</td> </tr> </tbody> </table> </td> </tr> </tbody> </table>		Required prior to the test	During the test	Ambient Temperature	20 to 30 °C	Relative Humidity	25 to 70 %	Fully configured sample scanned over the following frequency range	<table border="1"> <thead> <tr> <th>Frequency range on each side of line</th> <th>Measurement Point</th> </tr> </thead> <tbody> <tr> <td>9kHz – 30MHz</td> <td>10 m measurement distance</td> </tr> <tr> <td>30MHz – 25GHz</td> <td>3 m measurement distance</td> </tr> </tbody> </table>	Frequency range on each side of line	Measurement Point	9kHz – 30MHz	10 m measurement distance	30MHz – 25GHz
Required prior to the test	During the test														
Ambient Temperature	20 to 30 °C														
Relative Humidity	25 to 70 %														
Fully configured sample scanned over the following frequency range	<table border="1"> <thead> <tr> <th>Frequency range on each side of line</th> <th>Measurement Point</th> </tr> </thead> <tbody> <tr> <td>9kHz – 30MHz</td> <td>10 m measurement distance</td> </tr> <tr> <td>30MHz – 25GHz</td> <td>3 m measurement distance</td> </tr> </tbody> </table>	Frequency range on each side of line	Measurement Point	9kHz – 30MHz	10 m measurement distance	30MHz – 25GHz	3 m measurement distance								
Frequency range on each side of line	Measurement Point														
9kHz – 30MHz	10 m measurement distance														
30MHz – 25GHz	3 m measurement distance														
Limits – FCC Part 15.205, 15.209 (a), 15.247 (d) / RSS-GEN §8.9, §8.10, RSS-247 §5.5															
Frequency (MHz)	Limits (dBµV/m)														
	Level / Detector / Distance	Results													
0.009 to 0.090	107.6 – 87.6 / AV / 10m 127.6 – 107.6 / PK / 10m	Pass													
0.090 to 0.110	87.6 – 85.9 / QP / 10m	Pass													
0.110 to 0.490	85.7 – 72.9 / AV / 10m 105.7 – 92.9 / PK / 10m	Pass													
0.490 to 1.705	52.9 – 42.1 / QP / 10m	Pass													
1.705 to 30	48.6 / QP / 10m	Pass													
30 to 88	40.0 / QP / 3m	Pass													
88 to 216	43.5 / QP / 3m	Pass													
216 to 960	46.0 / QP / 3m	Pass													
960-1000	54.0 / QP / 3m	Pass													
Above 1GHz	54.0 / AV / 3m 74.0 / PK / 3m	Pass													
Supplementary information: Test location: SMEE Test date: November 30 th , 2023 by C KERMICHE. Power supply voltage: 5V DC from USB-Port.															

Graphical representation of Band-edge compliance (HIGH)

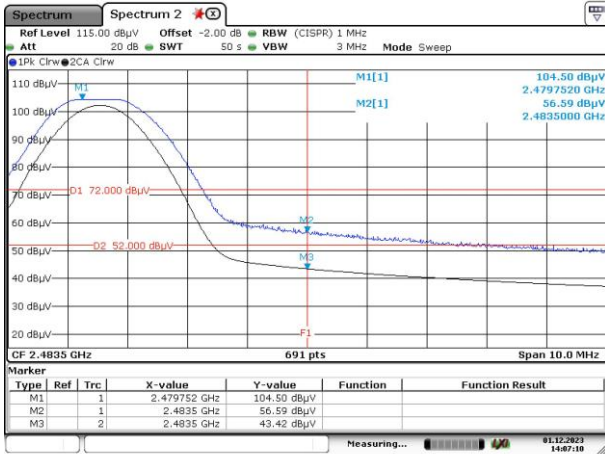

High band edge compliance: BLE/1Mbps

Radiated Peak level is 56.6 dBµV/m at 2483.5MHz (limit 74dBµV/m).
 Max radiated Average level is 43.4 dBµV/m (limit 54dBµV/m, CISPR Average detector measurement).

RESULT: PASS

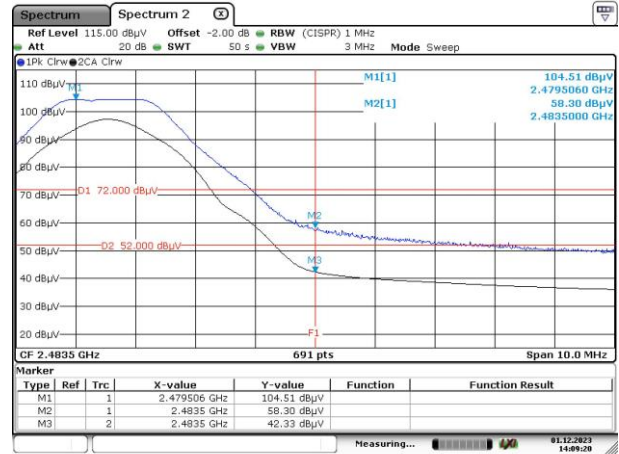

High band edge compliance: BLE/2Mbps

Radiated Peak level is 58.3 dBµV/m at 2483.5MHz (limit 74dBµV/m).
 Max radiated Average level is 42.3 dBµV/m (limit 54dBµV/m, CISPR Average detector measurement).

Graphical representation of Radiated Disturbance Measurement (Peak detection, Anechoic chamber pre-scan, 9kHz-30MHz / 3m / Parallel & Perpendicular antenna position / Transmit mode)

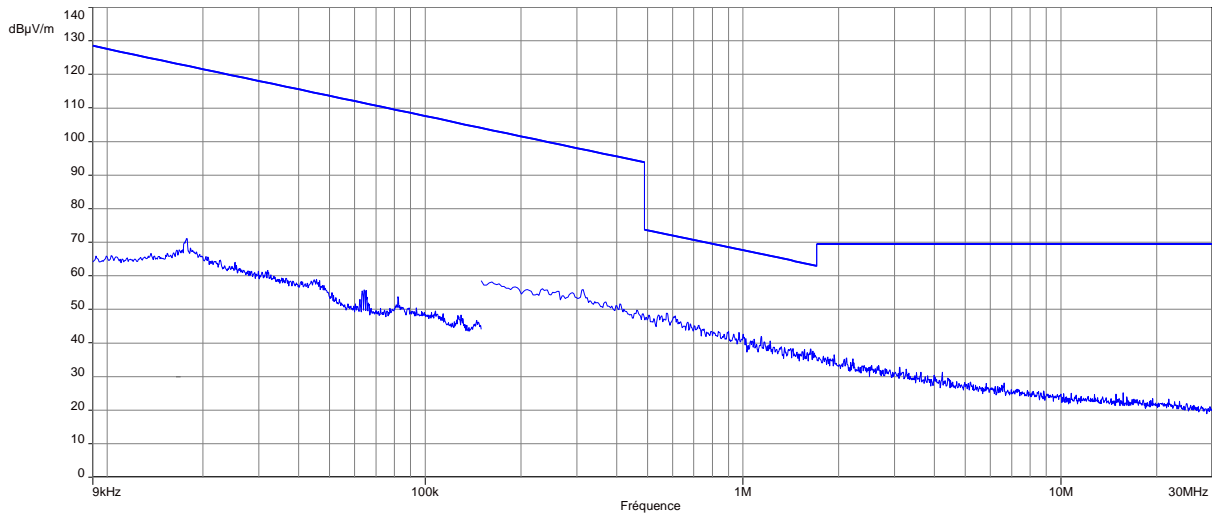

Notes: Pre-scan graph only for identification purpose. Same result for transmit mode on all channels.

Tabulated Results for Unwanted emissions (9kHz-490kHz)

FREQ	RF field @ 300m	Limit @ 300m	Detector	Margin	Ant. angle	Table angle	Correc. Fact. (CF)
MHz	dBµV/m	dBµV/m	Pk / QP / AV	dB	Degree	Degree	dB
All levels are at least 20dB below applicable limits							
Supplementary information: Frequency list measured has been created with pre-scan results.							
Frequency band investigated:		9kHz-490kHz					
RBW:		200Hz (9kHz-150kHz) 9kHz (150kHz-30MHz)					
Measurement distance:		10m					
Final measurement detector:		Peak / Quasi-Peak / Average					
Limit:		FCC Part 15.209 / RSS-Gen					
Note:		CF: Correction factor = Antenna factor + Cable loss (M@300m = M@10m-59.1dB) Loop antenna used and rotated about its axis to maximize any emission.					

Tabulated Results for Unwanted emissions (490kHz-30MHz)

FREQ	RF field @ 30m	Limit @ 30m	Detector	Margin	Ant. angle	Table angle	Correc. Fact. (CF)
MHz	dBµV/m	dBµV/m	Pk / QP	dB	Degree	Degree	dB
All levels are at least 20dB below applicable limits							
Supplementary information: Frequency list measured has been created with pre-scan results.							
Frequency band investigated:		490kHz-30MHz					
RBW:		9kHz (150kHz-30MHz)					
Measurement distance:		10m					
Final measurement detector:		Quasi-Peak					
Limit:		FCC Part 15.209 / RSS-Gen					
Note:		CF: Correction factor = Antenna factor + Cable loss (M@30m = M@10m-19.1dB) Loop antenna used and rotated about its axis to maximize any emission.					

Graphical of Radiated Disturbance Measurement (Peak and Average Measurement, 30Mz-25GHz)

Tx / 2402MHz

HORIZONTAL POLARIZATION

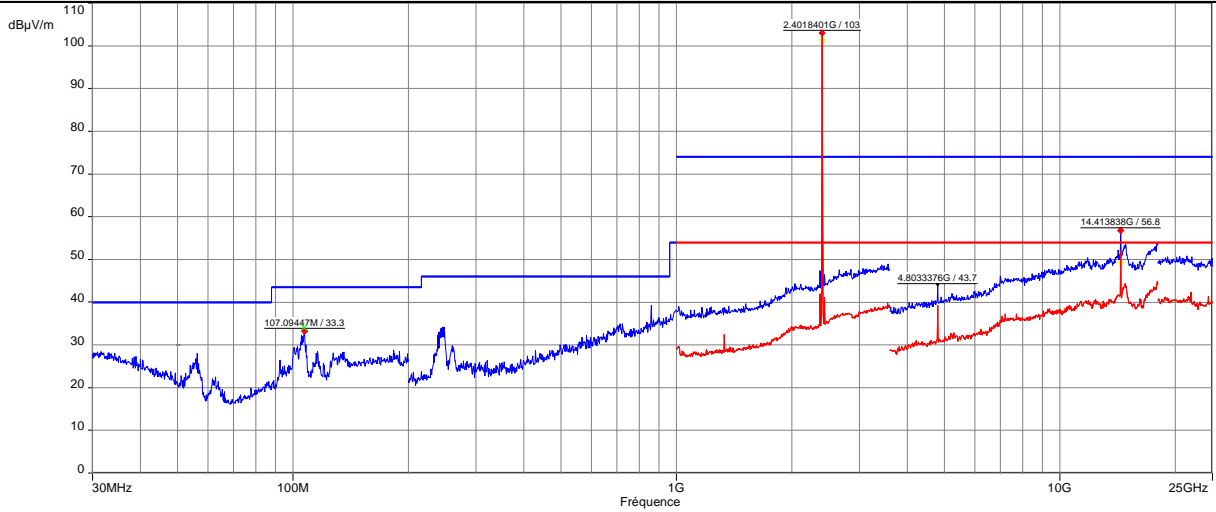

VERTICAL POLARIZATION

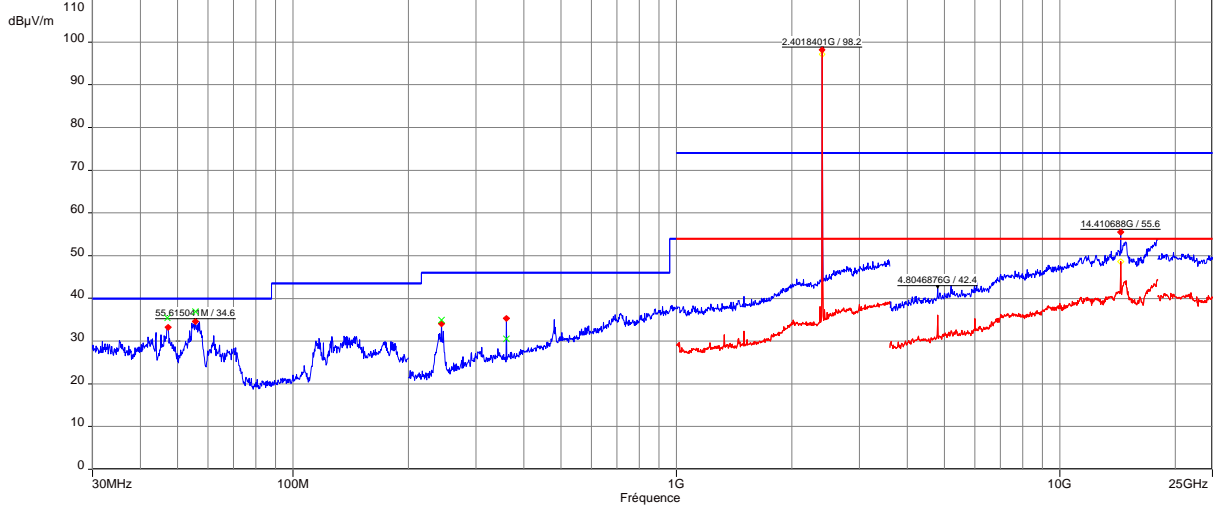

FREQ (MHz)	Field Strength 3m PK (dBµV/m)	Field Strength 3m QP or AV (dBµV/m)	Limit Peak (dBµV/m)	Limit QP or AV (dBµV/m)	Margin Peak (dB)	Margin QP or AV (dB)	Result	PoI	Detector & Limit
106.889453	34.10	26.41	-	43.50	-	-17.09	Pass	H	QP
47.023169	35.45	28.52	-	40.00	-	-11.48	Pass	V	QP
55.634524	36.89	28.87	-	40.00	-	-11.13	Pass	V	QP
244.22209	34.96	26.65	-	46.00	-	-19.35	Pass	V	QP
359.99432	30.58	29.19	-	46.00	-	-16.81	Pass	V	QP
Frequency and Limit band:		30Mz-25GHz / FCC 15.209 / RSS-GEN							
RBW and Limit detector:		Below 1GHz: RBW= 100kHz, Quasi-Peak Limit / above 1GHz: RBW= 1MHz, Peak and Average Limit							
Note:		Pre-scan graph only for identification purpose.							

Graphical of Radiated Disturbance Measurement (Peak and Average Measurement, 30Mz-25GHz)

Tx / 2440MHz

HORIZONTAL POLARIZATION

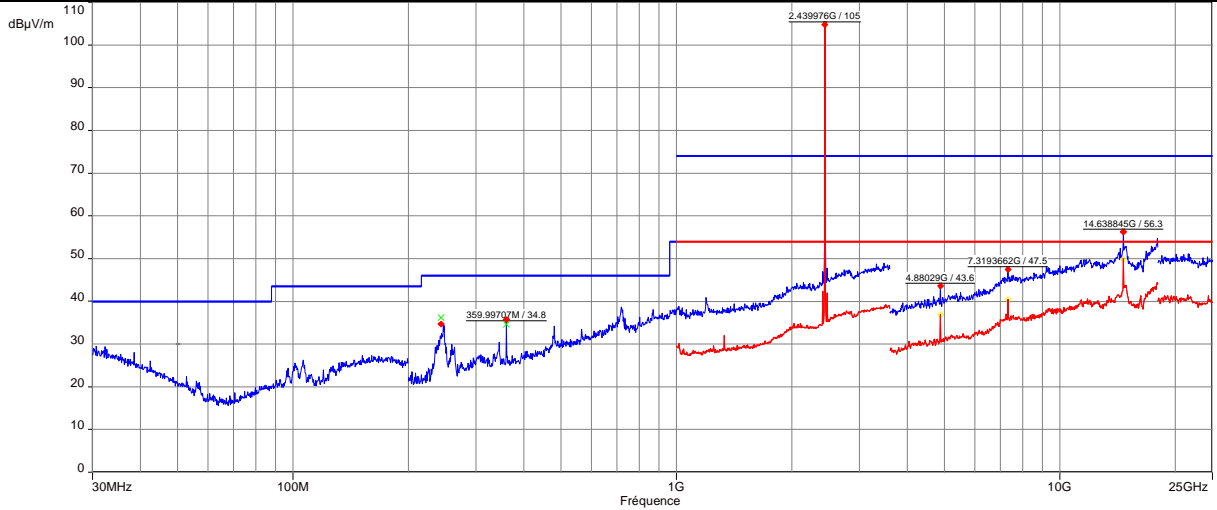

VERTICAL POLARIZATION

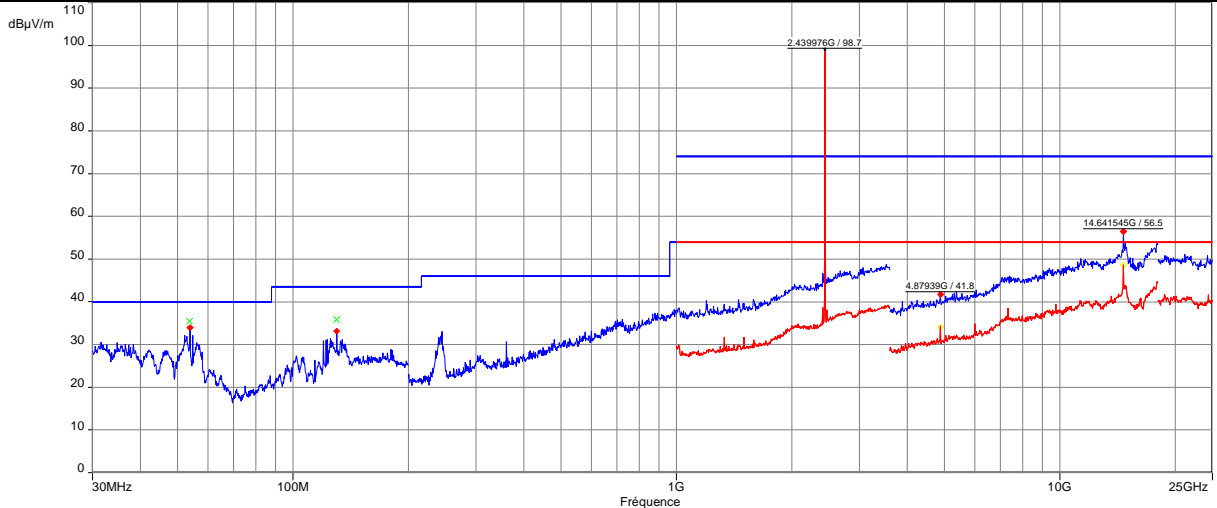

FREQ (MHz)	Field Strength 3m PK (dBµV/m)	Field Strength 3m QP or AV (dBµV/m)	Limit Peak (dBµV/m)	Limit QP or AV (dBµV/m)	Margin Peak (dB)	Margin QP or AV (dB)	Result	PoI	Detector & Limit
243.259817	36.18	28.63	-	46.00	-	-17.37	Pass	H	QP
359.9970665	34.57	33.39	-	46.00	-	-12.61	Pass	H	QP
4879.73858	45.26	35.83	74.00	54.00	-28.74	-18.17	Pass	H	PK/AV
7320.70307	49.86	39.03	74.00	54.00	-24.14	-14.97	Pass	H	PK/AV
53.781213	35.41	24.74	-	40.00	-	-15.26	Pass	V	QP
130.14918	35.82	23.48	-	43.50	-	-20.02	Pass	V	QP
Frequency and Limit band:		30Mz-25GHz / FCC 15.209 / RSS-GEN							
RBW and Limit detector:		Below 1GHz: RBW= 100kHz, Quasi-Peak Limit / above 1GHz: RBW= 1MHz, Peak and Average Limit							
Note:		Pre-scan graph only for identification purpose.							

Graphical of Radiated Disturbance Measurement (Peak and Average Measurement, 30Mz-25GHz)

Tx / 2480MHz

HORIZONTAL POLARIZATION

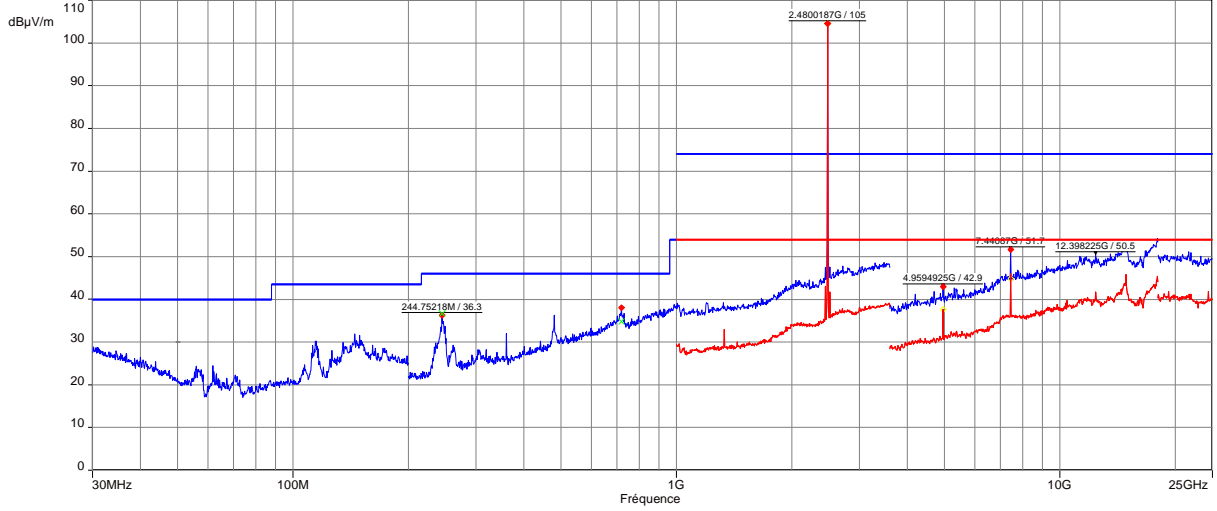

VERTICAL POLARIZATION

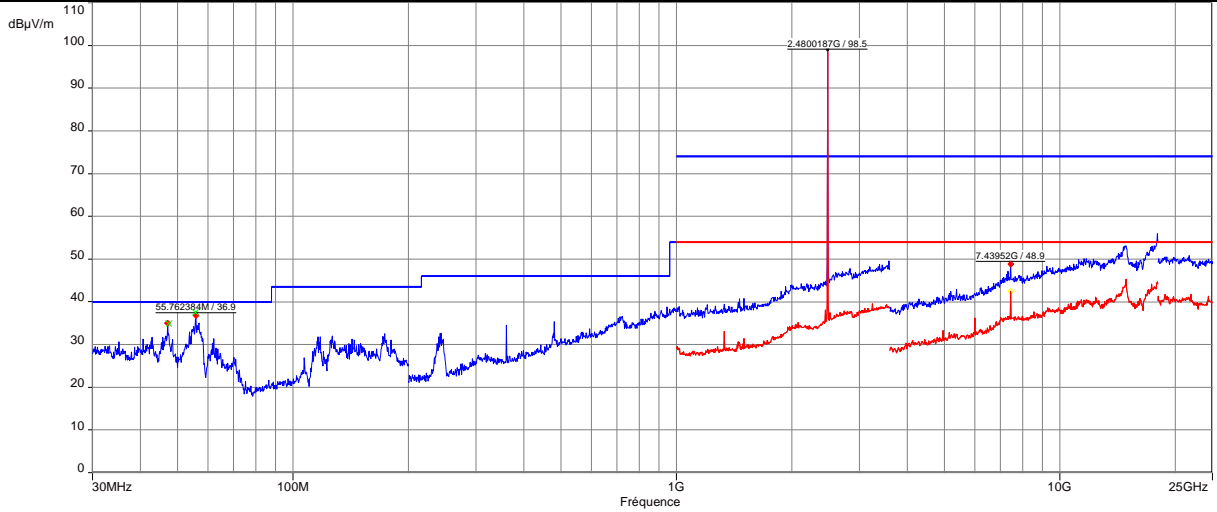

FREQ (MHz)	Field Strength 3m PK (dBµV/m)	Field Strength 3m QP or AV (dBµV/m)	Limit Peak (dBµV/m)	Limit QP or AV (dBµV/m)	Margin Peak (dB)	Margin QP or AV (dB)	Result	Pol	Detector & Limit
244.502197	36.70	30.70	-	46.00	-	-15.30	Pass	H	QP
718.755373	34.85	27.68	-	46.00	-	-18.32	Pass	H	QP
4959.27452	43.66	32.94	74.00	54.00	-30.34	-21.06	Pass	H	PK/AV
7440.7625	53.36	43.57	74.00	54.00	-20.64	-10.43	Pass	H	PK/AV
47.350258	34.90	27.54	-	40.00	-	-12.46	Pass	V	QP
55.654334	37.58	29.35	-	40.00	-	-10.65	Pass	V	QP
7438.81708	46.33	32.77	74.00	54.00	-27.67	-21.23	Pass	V	PK/AV
Frequency and Limit band:		30Mz-25GHz / FCC 15.209 / RSS-GEN							
RBW and Limit detector:		Below 1GHz: RBW= 100kHz, Quasi-Peak Limit / above 1GHz: RBW= 1MHz, Peak and Average Limit							
Note:		Pre-scan graph only for identification purpose.							

16. Occupied bandwidth (99%)

TEST: Occupied bandwidth (99%) / RSS-GEN		Verdict
<p>Method: The setup is in an anechoic chamber. The spectrum analyzer is connected to the measuring antenna. A radiated measurement is performed. The RBW is set in the range of 1% to 5% of the OBW, with VBW ≥ 3 x RBW. The SPAN is wide enough to capture all products of the modulation process. (Between 1.5 to 5 times the OBW). A MaxHold Peak detector is used. Automatic function of the spectrum analyser is used. The tested equipment is set to transmit operation with modulation on low, mid and high channels.</p>		Pass
Laboratory Parameters:	Required prior to the test	During the test
Ambient Temperature	20 to 30 °C	21°C ± 2
Relative Humidity	25 to 70 %	48% ± 5
<p>Supplementary information: Test location: SMEE Test date: December 1st, 2023 Power supply voltage: 5V DC from USB-Port. Power setting: 10dBm.</p>		

Tabulated Results for 99% Occupied Bandwidth	
Frequency (MHz)	99% Occupied Bandwidth (MHz)
BLE: 1Mbps	
2402.0	1.046
2440.0	1.033
2480.0	1.043
BLE: 2Mbps	
2402.0	2.090
2440.0	2.070
2480.0	2.080

Graphical representation of 99% Occupied Bandwidth / BLE: 1Mbps

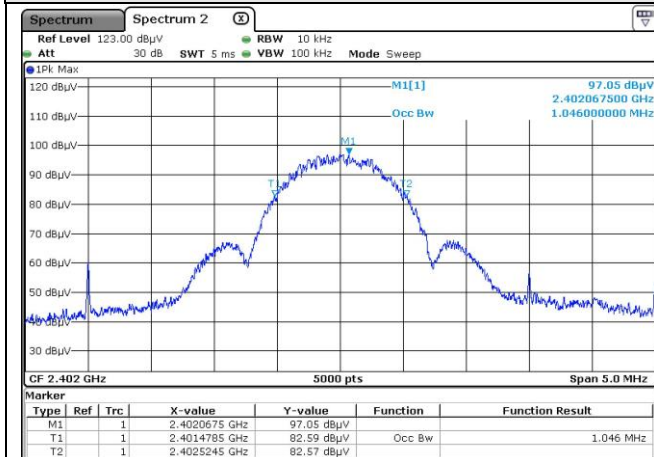

Low channel

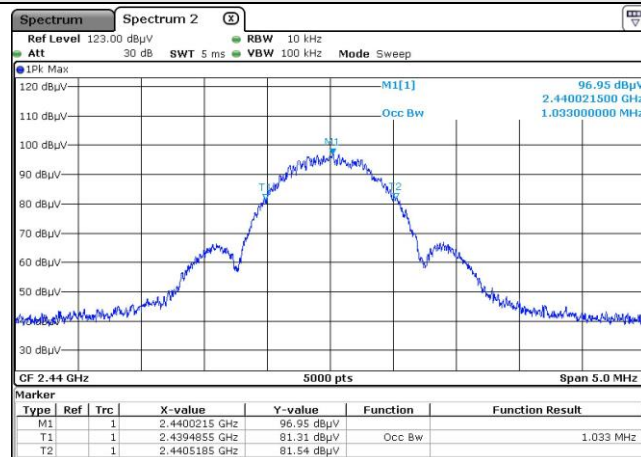

Mid channel

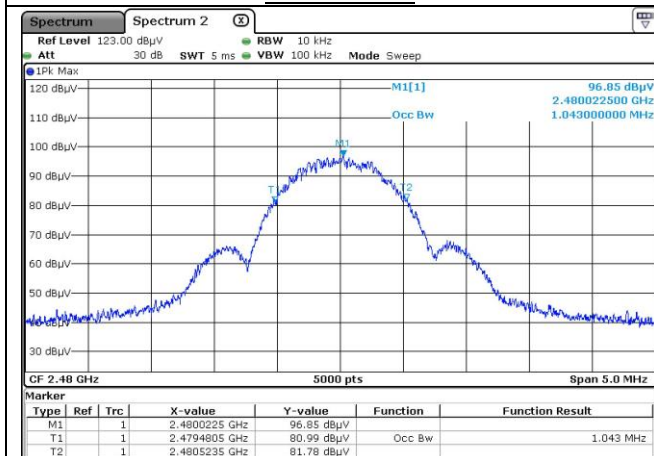

High channel

Frequency band investigated:	2402MHz to 2480MHz
RBW :	10kHz
Measurement detector:	Peak

Graphical representation of 99% Occupied Bandwidth / BLE: 2Mbps

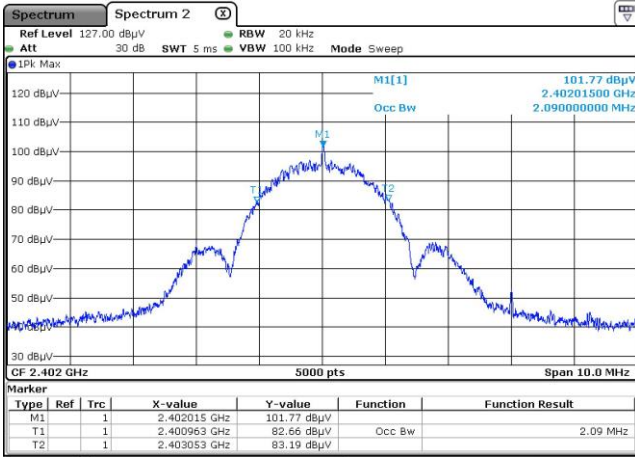

Low channel

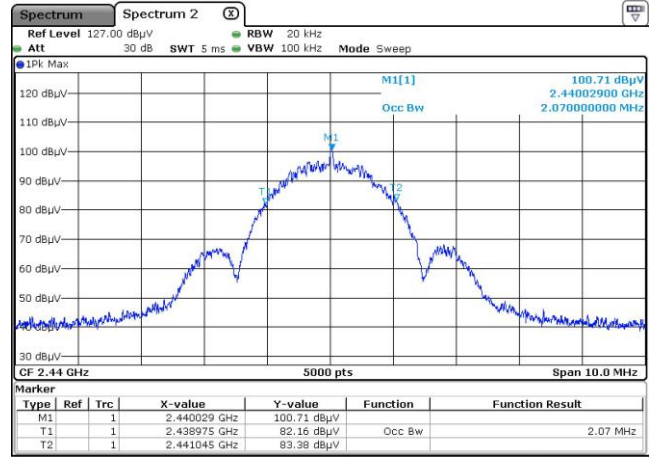

Mid channel

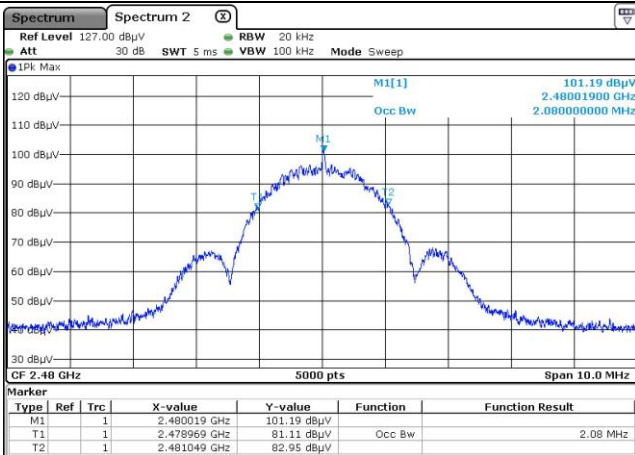

High channel

Frequency band investigated:	2402MHz to 2480MHz
RBW:	10kHz
Measurement detector:	Peak

17. Test Equipment List

Test Equipment Used for conducted emission					
Description	Manufacturer	Model	Identifier	Cal. Date	Cal. Due
AC power supply	PACIFIC POWER	AMX-125	ALI-101-002	2023/8	2024/8
Attenuator / limiter	SMEE	ATT#2	ATT-171-010	2023/4	2024/3
RF cable	RADIALL	RG58 / BNC / 5m	CAB-211-042	2023/4	2024/3
Measuring receiver	Rohde&Schwarz	ESRP	REC-151-002	2021/12	2023/12
LISN (50Ω / 50μH)	AFJ	LS16C	RSI-101-001	2023/7	2025/7
EMC Software	NEXIO	BAT EMC	SOF-101-001	-	-

Test Equipment Used for conducted antenna port measurement					
Description	Manufacturer	Model	Identifier	Cal. Date	Cal. Due
RF Attenuator	Mini-Circuit	BW-N10W5+	ATT-171-008	2023/4	2024/4
Spectrum analyzer	Rohde&Schwarz	FSV40	ASP-171-004	2021/10	2024/01
Measuring receiver	Rohde&Schwarz	ESRP	REC-151-002	2021/12	2023/12
EMC Software	NEXIO	BAT EMC	SOF-101-001	-	-

Test Equipment Used for radiated emission					
Description	Manufacturer	Model	Identifier	Cal. Date	Cal. Due
AC power supply	PACIFIC POWER	AMX-125	ALI-101-002	2023/8	2024/8
Horn antenna	COM-POWER	AH-118	ANT-101-004	2021/7	2024/7
Loop antenna	EMCO	6502	ANT-101-009	2023/9	2025/9
Horn antenna	ETS-LINDGREN	3116	ANT-161-014	2021/7	2024/7
Log-periodic antenna	EMCO	3146	ANT-191-019	2021/7	2024/01
Biconnic antenna	COM-POWER	AB- 900A	ANT-201-021	2023/01	2025/01
Spectrum analyzer	Rohde&Schwarz	FSV40	ASP-171-004	2021/10	2024/01
RF cable	Div	OATS/25m	CAB-101-017	2023/4	2024/4
RF cable	HUBER+SUHNER	SF102 (K/2m)	CAB-171-034	2023/4	2024/4
RF cable	HUBER+SUHNER	SF102 (K/3m)	CAB-171-035	2023/4	2024/4
RF cable	RADIALL	R286301073	CAB-201-036	2023/4	2024/4
RF cable	HUBER+SUHNER	SF126E (NN/2m)	CAB-231-043	2023/4	2024/4
RF cable	HUBER+SUHNER	SF104E (NN/5,3m)	CAB-231-044	2023/4	2024/4
RF cable	HUBER+SUHNER	SF104E (NN/7m)	CAB-231-045	2023/4	2024/4
Semi anechoic room	COMTEST	218292	CAG-201-002	2022/4	2025/4
High-pass filter	RF-Lambda	RHPF23G03G18	FIL-221-011	2023/4	2024/4

Test Equipment Used for radiated emission					
Description	Manufacturer	Model	Identifier	Cal. Date	Cal. Due
Antenna mast SAC	Innco- Systems	MA4640-XP-ET	MAT-201-002	-	-
Turntable SAC	Innco- Systems	DS1500-S-1t	PLA-201-003	-	-
Pre-amplifier	SMEE	18-40GHz	PRE-171-004	2023/4	2024/4
Pre-amplifier	COM-POWER	1-18GHz	PRE-221-005	2023/4	2024/4
Measuring receiver	Rohde&Schwarz	ESRP	REC-151-002	2021/12	2023/12
FS OATS	Div	10m	SIT-201-002	-	-
EMC Software	NEXIO	BAT EMC	SOF-101-001	-	-

END OF REPORT