



LCIE

Bluetooth Low Energy Template: Release October 12th, 2021

TEST REPORT

N°: 13401919-775370-C(FILE#3629385)

Version : 01

Subject

Radio spectrum matters
tests according to standards:
47 CFR Part 15.247 & RSS-247 Issue 2 & RSS-Gen Issue 5.2

Issued to

STMICROELECTRONICS SAS
190 Avenue Celestin Coq
13106 - Rousset
France

Apparatus under test

- ↪ Product
- ↪ Trade mark
- ↪ Manufacturer
- ↪ Model under test
- ↪ Serial number
- ↪ FCC ID
- ↪ IC

Chip enabling the user to communicate data through a
Wireless interface

STMICROELECTRONICS
STMICROELECTRONICS
STM32WB5MMGH
Sample RF & Sample 9
YCP-32WB5MMGH02
8976A-32WB5MMGH02

Conclusion

See Test Program chapter

Test date

April 12, 2022 to May 13, 2022

Test location

Moirans

FCC Test site

FR0008 - 197516

ISED Test site

FR0008 - 6500A

Sample receipt date

April 12, 2022

Composition of document

61 pages

Document issued on

May 17, 2022

Written by :

Gaëtan DESCHAMPS

Tests operator

Approved by :

Anthony MERLIN

Technical manager

This document shall not be reproduced, except in full, without the written approval of the LCIE. This document contains results related only to the items tested. It does not imply the conformity of the whole production to the items tested. Unless otherwise specified or rule defined by the test method, the decision of conformity doesn't take into account the uncertainty of measures. This document doesn't anticipate any certification decision.

LCIE

Laboratoire Central des Industries Electriques
Une société de Bureau Veritas

ZI Centr'alp
170 rue de Chatagnon
38430 Moirans FRANCE

Tél : +33 4 76 07 36 36
contact@lcie.fr
www.lcie.fr



PUBLICATION HISTORY

Version	Date	Author	Modification
01	May 17, 2022	Gaetan DESCHAMPS	Creation of the document

Each new edition of this test report replaces and cancels the previous edition. The control of the old editions of report is under responsibility of client.



SUMMARY

1. TEST PROGRAM 4

2. EQUIPMENT UNDER TEST: CONFIGURATION (DECLARED BY PROVIDER) 5

3. OCCUPIED BANDWIDTH..... 9

4. 6DB EMISSION BANDWIDTH 13

5. MAXIMUM CONDUCTED OUTPUT POWER 17

6. POWER SPECTRAL DENSITY 22

7. UNWANTED EMISSIONS INTO NON-RESTRICTED FREQUENCY BANDS AT THE BAND EDGE 26

8. UNWANTED EMISSIONS INTO NON-RESTRICTED FREQUENCY BANDS..... 30

9. AC POWER LINE CONDUCTED EMISSIONS..... 34

10. UNWANTED EMISSIONS IN RESTRICTED FREQUENCY BANDS 46

11. UNCERTAINTIES CHART 61



1. TEST PROGRAM

References

- 47 CFR Part 15.247
- RSS 247 Issue 2
- RSS Gen Issue 5
- KDB 558074 D01 DTS Meas Guidance v05r02
- ANSI C63.10-2013

Radio requirement:

Clause (47CFR Part 15.247 & RSS-247 Issue 2 & RSS-Gen Issue 5) Test Description	Test result - Comments
Occupied Bandwidth	<input checked="" type="checkbox"/> PASS <input type="checkbox"/> FAIL <input type="checkbox"/> NA <input type="checkbox"/> NP(1)
6dB Bandwidth	<input checked="" type="checkbox"/> PASS <input type="checkbox"/> FAIL <input type="checkbox"/> NA() <input type="checkbox"/> NP(1)
Duty Cycle	<input type="checkbox"/> PASS <input type="checkbox"/> FAIL <input checked="" type="checkbox"/> NA <input type="checkbox"/> NP(1)
Maximum Conducted Output Power	<input checked="" type="checkbox"/> PASS <input type="checkbox"/> FAIL <input type="checkbox"/> NA <input type="checkbox"/> NP(1)
Power Spectral Density	<input checked="" type="checkbox"/> PASS <input type="checkbox"/> FAIL <input type="checkbox"/> NA <input type="checkbox"/> NP(1)
Conducted Spurious Emission at the Band Edge	<input checked="" type="checkbox"/> PASS <input type="checkbox"/> FAIL <input type="checkbox"/> NA() <input type="checkbox"/> NP(1)
Unwanted Emissions into Non-Restricted Frequency Bands	<input checked="" type="checkbox"/> PASS <input type="checkbox"/> FAIL <input type="checkbox"/> NA() <input type="checkbox"/> NP(1)
AC Power Line Conducted Emission	<input checked="" type="checkbox"/> PASS <input type="checkbox"/> FAIL <input type="checkbox"/> NA(2) <input type="checkbox"/> NP(1)
Unwanted Emissions into Restricted Frequency Bands	<input checked="" type="checkbox"/> PASS <input type="checkbox"/> FAIL <input type="checkbox"/> NA <input type="checkbox"/> NP(1)
Receiver Radiated emissions	<input type="checkbox"/> PASS <input type="checkbox"/> FAIL <input checked="" type="checkbox"/> NA <input type="checkbox"/> NP(1)
This table is a summary of test report, see conclusion of each clause of this test report for detail.	

(1): Limited program

(2): EUT not directly or indirectly connected to the AC Power Public Network

PASS: EUT complies with standard's requirement

FAIL: EUT does not comply with standard's requirement

NA: Not Applicable

NP: Test Not Performed

2. EQUIPMENT UNDER TEST: CONFIGURATION (DECLARED BY PROVIDER)

2.1. HARDWARE IDENTIFICATION (EUT AND AUXILIARIES):

Equipment under test (EUT):

STMICROELECTRONICS STM32WB5MMGH

Serial Number: Sample RF & Sample 9

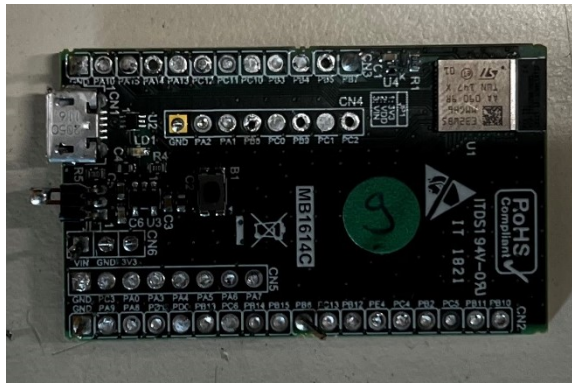

Equipment Under Test

Power supply:

During all the tests, EUT is supplied by V_{nom} : 3.3VDC

For measurement with different voltage, it will be presented in test method.

Name	Type	Rating	Reference / Sn	Comments
Supply1	<input type="checkbox"/> AC <input checked="" type="checkbox"/> DC <input type="checkbox"/> Battery	3.3VDC	-	-

Inputs/outputs - Cable:

Access	Type	Length used (m)	Declared <3m	Shielded	Under test	Comments
1	USB	1	<input type="checkbox"/>	<input checked="" type="checkbox"/>	<input checked="" type="checkbox"/>	Tested only for the AC power Line test
2	DC	1.5	<input type="checkbox"/>	<input type="checkbox"/>	<input checked="" type="checkbox"/>	Used only for all tests in the report

Auxiliary equipment used during test:

Type	Reference	Sn	Comments
LAPTOP	Lenovo	LP2	-
Power Supply USB	SOY	-	-





Voltage table used (for Power Line Conducted Emissions):

Type	Measurement performed:	
<input checked="" type="checkbox"/> AC (power supply, typically)	<input checked="" type="checkbox"/> 120VAC/60Hz	<input type="checkbox"/> 240VAC/50Hz
<input type="checkbox"/> DC	<input type="checkbox"/> +12VDC	<input type="checkbox"/> -...VDC
<input type="checkbox"/> Battery	<input type="checkbox"/> +3.6VDC	<input type="checkbox"/> -...VDC
<input checked="" type="checkbox"/> USB (Laptop auxiliary)	<input checked="" type="checkbox"/> 120VAC/60Hz (Laptop auxiliary)	<input checked="" type="checkbox"/> 240VAC/50Hz(Laptop auxiliary)

Equipment information:

Bluetooth LE Type:	<input type="checkbox"/> BLE	<input type="checkbox"/> v4.1	<input type="checkbox"/> v4.2	<input checked="" type="checkbox"/> v5.0
Frequency band:	[2400 – 2483.5] MHz			
Spectrum Modulation:	<input checked="" type="checkbox"/> DSSS (Tested like it)			
Number of Channel:	40			
Spacing channel:	2MHz			
Channel bandwidth:	<input checked="" type="checkbox"/> 1MHz	<input checked="" type="checkbox"/> 2MHz		
Antenna Type:	<input checked="" type="checkbox"/> Integral	<input type="checkbox"/> External	<input type="checkbox"/> Dedicated	
Antenna connector:	<input type="checkbox"/> Yes	<input checked="" type="checkbox"/> No	<input checked="" type="checkbox"/> Temporary for test	
Transmit chains:	1			
	Single antenna			
	Gain: 1.9dBi			
Antenna requirements §15.203	Conducted Method (welded connection, according to manufacturer's requirements)			
Type of equipment:	<input checked="" type="checkbox"/> Stand-alone	<input type="checkbox"/> Plug-in	<input type="checkbox"/> Combined	
Duty cycle:	<input checked="" type="checkbox"/> Continuous duty	<input type="checkbox"/> Intermittent duty	<input type="checkbox"/> 100% duty	
Equipment type:	<input checked="" type="checkbox"/> Production model		<input type="checkbox"/> Pre-production model	
Operating temperature range:	Tmin:	<input type="checkbox"/> -20°C	<input type="checkbox"/> 0°C	<input checked="" type="checkbox"/> 40°C
	Tnom:	20°C		
	Tmax:	<input type="checkbox"/> 35°C	<input type="checkbox"/> 55°C	<input checked="" type="checkbox"/> 85°C
Type of power source:	<input type="checkbox"/> AC power supply	<input checked="" type="checkbox"/> DC power supply	<input checked="" type="checkbox"/> Battery	
Operating voltage range:	Vnom:	<input type="checkbox"/> 230V/50Hz	<input checked="" type="checkbox"/> 3.3Vdc	



L C I E

CHANNEL PLAN			
Channel	Frequency (MHz)	Channel	Frequency (MHz)
Cmin: 0	2402	Cmid: 20	2442
1	2404	21	2444
2	2406	22	2446
3	2408	23	2448
4	2410	24	2450
5	2412	25	2452
6	2414	26	2454
7	2416	27	2456
8	2418	28	2458
9	2420	29	2460
10	2422	30	2462
11	2424	31	2464
12	2426	32	2466
13	2428	33	2468
14	2430	34	2470
15	2432	35	2472
16	2434	36	2474
17	2436	37	2476
18	2438	38	2478
19	2440	Cmax: 39	2480

DATA RATE			
Available	Data Rate (Mbps)	Modulation Type	Worst Case Modulation
<input type="checkbox"/>	0.25	GFSK	<input type="checkbox"/>
<input type="checkbox"/>	1	GFSK	<input checked="" type="checkbox"/>
<input type="checkbox"/>	2	GFSK	<input type="checkbox"/>



2.2. RUNNING MODE

Test mode	Description of test mode
Test mode 1	Permanent emission with modulation on a fixed channel in the data rate that produced the highest power
Test mode 2	Permanent reception
Test	Running mode
Occupied Bandwidth	<input checked="" type="checkbox"/> Test mode 1 <input type="checkbox"/> Alternative test mode()
6dB Bandwidth	<input checked="" type="checkbox"/> Test mode 1 <input type="checkbox"/> Alternative test mode()
Maximum Conducted Output Power	<input checked="" type="checkbox"/> Test mode 1 <input type="checkbox"/> Alternative test mode()
Power Spectral Density	<input checked="" type="checkbox"/> Test mode 1 <input type="checkbox"/> Alternative test mode()
Conducted Spurious Emission at the Band Edge	<input checked="" type="checkbox"/> Test mode 1 <input type="checkbox"/> Alternative test mode()
Unwanted Emissions into Non-Restricted Frequency Bands	<input checked="" type="checkbox"/> Test mode 1 <input type="checkbox"/> Alternative test mode()
AC Power Line Conducted Emission	<input checked="" type="checkbox"/> Test mode 1 <input type="checkbox"/> Alternative test mode()
Unwanted Emissions into Restricted Frequency Bands	<input checked="" type="checkbox"/> Test mode 1 <input type="checkbox"/> Alternative test mode()

Hardware information		
Software (if applicable):STM32CubeMonitor RF	V. :	2.8.1

2.3. EQUIPMENT LABELLING

None

2.4. EQUIPMENT MODIFICATION

None Modification:

3. OCCUPIED BANDWIDTH

3.1. TEST CONDITIONS

Test performed by : Gaetan DESCHAMPS
Date of test : May 10, 2022
Ambient temperature : 25 °C
Relative humidity : 45 %

3.2. TEST SETUP

- The Equipment under Test is installed:

- On a table
- In an anechoic chamber

- Measurement is performed with a spectrum analyzer in:

- Conducted Method
- Radiated Method

- Test Procedure:

- RSS-Gen Issue 5 § 6.7
- ANSI C63.10 § 6.9.2

Measurement Procedure:

- a) RBW shall be in the range of 1% to 5% of the anticipated occupied bandwidth
- b) Set the video bandwidth (VBW) $\geq 3 \times$ RBW
- c) SPAN = Capture all products of the modulation process
- d) Detector = Peak.
- e) Trace mode = max hold.
- f) Sweep = auto couple.
- g) Allow the trace to stabilize.
- h) OBW 99% function of spectrum analyzer used

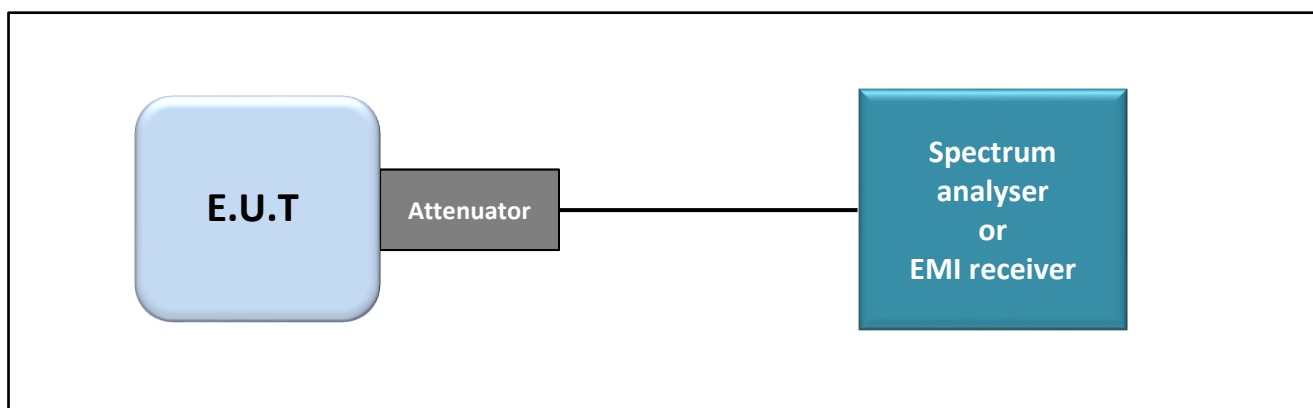

Test set up of Occupied Bandwidth



LCIE

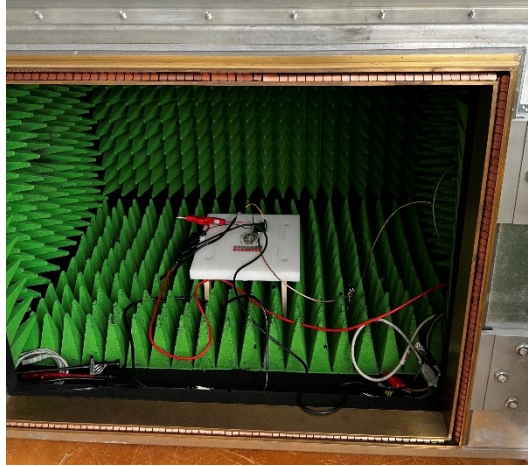

Photograph for Occupied bandwidth

3.3. LIMIT

None

3.4. TEST EQUIPMENT LIST

TEST EQUIPMENT USED					
Description	Manufacturer	Model	Identifier	Cal_Date	Cal_Due
SOFT	LCIE SUD EST	LCIE FCC 247 (BLE_ZIGBEE...)	L2000059		
CABLE SMA 1m	RADIALL	18GHz	A5329862	04/21	04/23
Full Anechoic Room	SIEPEL	-	D3044024		
Multimeter - CEM	FLUKE	87	A1240251	03/21	03/23
Power supply DC	METRIX	AX503	A7042307		
SMA 1.5m	SUCOFLEX	18GHz	A5329863	04/21	04/22
Spectrum analyzer	ROHDE & SCHWARZ	FSV 40	A4060059	11/21	11/23
Thermo-hygrometer	TESTO	608-H1	B4204120	12/20	12/22
Thermo-hygrometer (PM1/2/3)	KIMO	HQ 210	B4206022	01/21	01/23
Splitter	JFW	50PD-292	A7132009	06/20	06/22

Note: In our quality system, the test equipment calibration due is more & less 2 months



L C I E

3.5. RESULTS

1Mbits/s

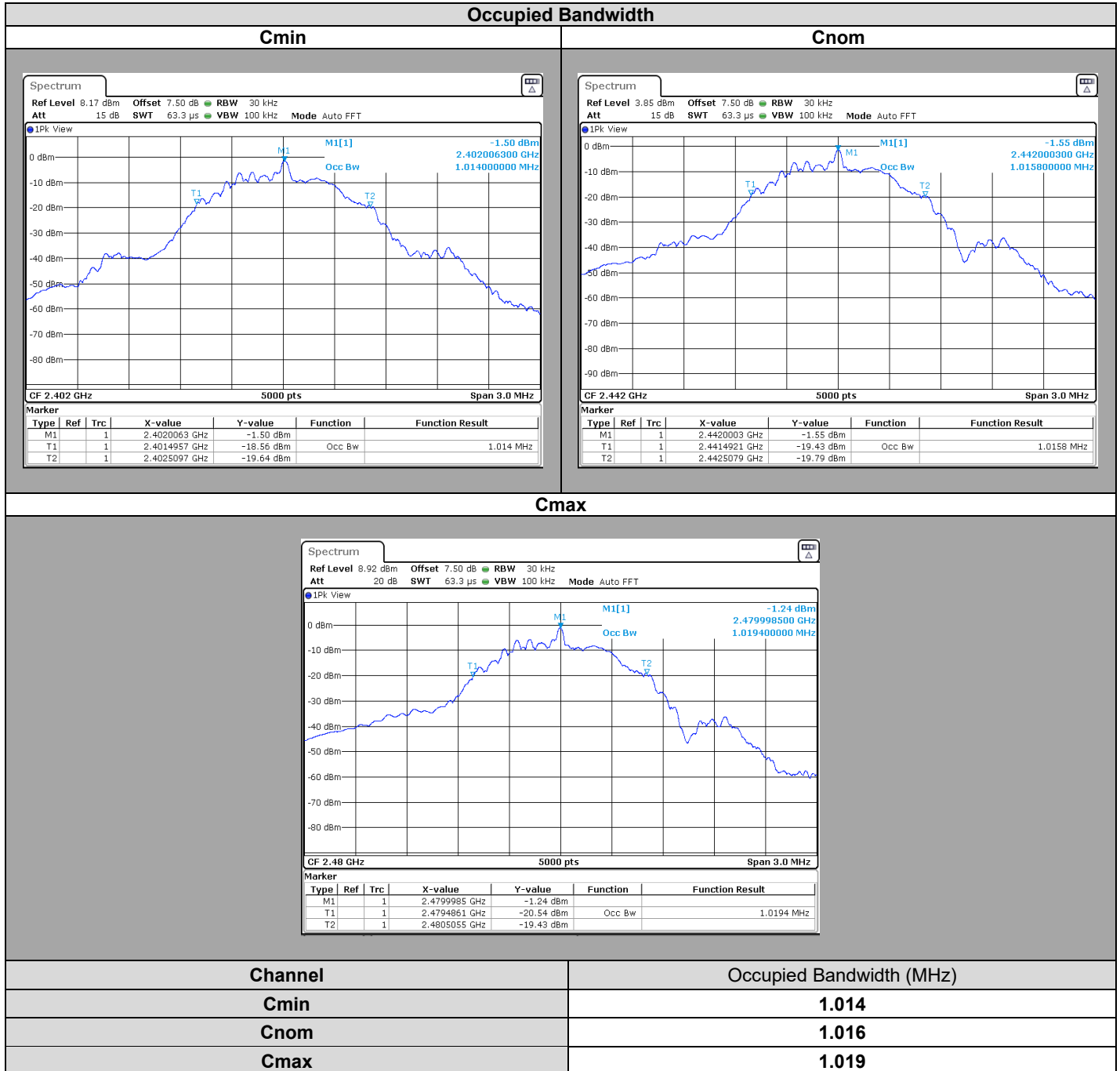

2Mbits/s

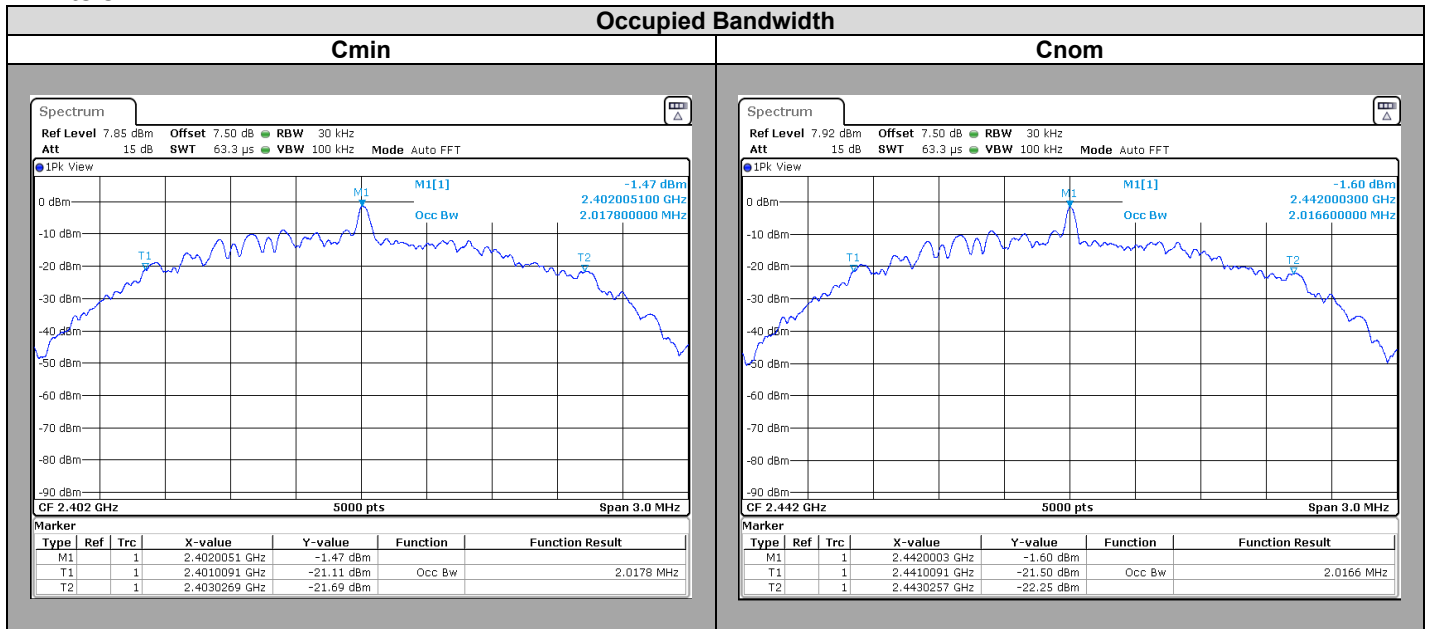

Cmax

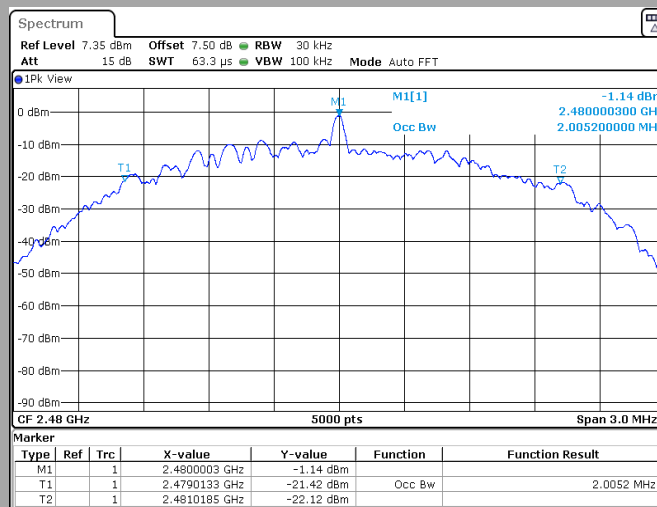

Channel	Occupied Bandwidth (MHz)
Cmin	2.0178
Cnom	2.0166
Cmax	2.0052

3.6. CONCLUSION

Occupied Channel Bandwidth measurement performed on the sample of the product **STMICROELECTRONICS STM32WB5MMGH**, SN: **Sample RF**, in configuration and description presented in this test report, show levels **compliant** to the **47 CFR PART 15.247 & RSS-GEN** limits.

4. 6DB EMISSION BANDWIDTH

4.1. TEST CONDITIONS

Test performed by : Gaetan DESCHAMPS
Date of test : May 10, 2022
Ambient temperature : 25 °C
Relative humidity : 45 %

4.2. TEST SETUP

- The Equipment under Test is installed:

- On a table
- In an anechoic chamber

- Measurement is performed with a spectrum analyzer in:

- Conducted Method
- Radiated Method

- Test Procedure:

- KDB 558074 D01 DTS Meas Guidance v05r02 § 8.2

Measurement Procedure:

1. Set resolution bandwidth (RBW) = 100kHz.
2. Set the video bandwidth (VBW) $\geq 3 \times$ RBW.
3. Detector = Peak.
4. Trace mode = max hold.
5. Sweep = auto couple.
6. Allow the trace to stabilize.
7. Measure the maximum width of the emission that is constrained by the frequencies associated with the two outermost amplitude points (upper and lower) that are attenuated by 6 dB relative to the maximum level measured in the fundamental emission. Compare the resultant bandwidth with the RBW setting of the analyzer.

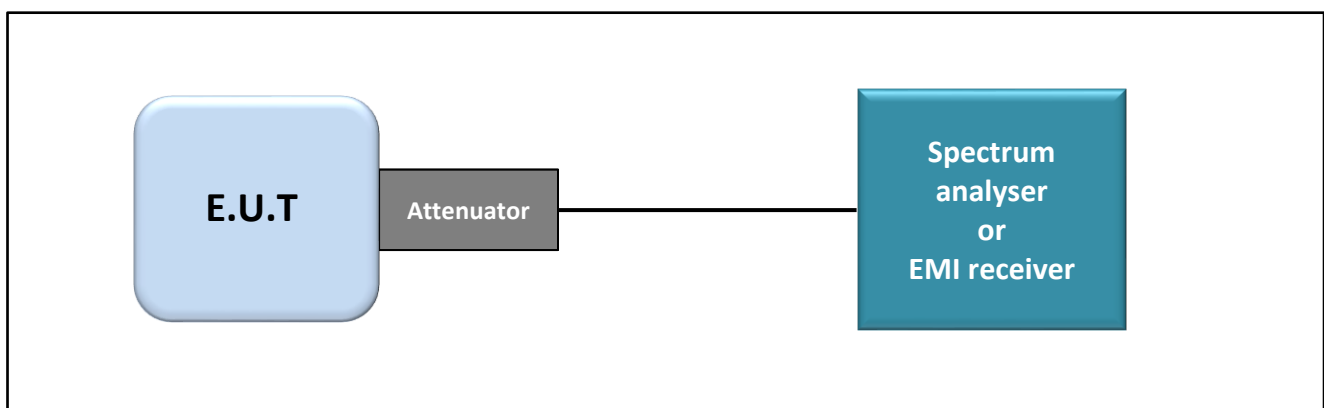

Test set up of 6dB Emission Bandwidth

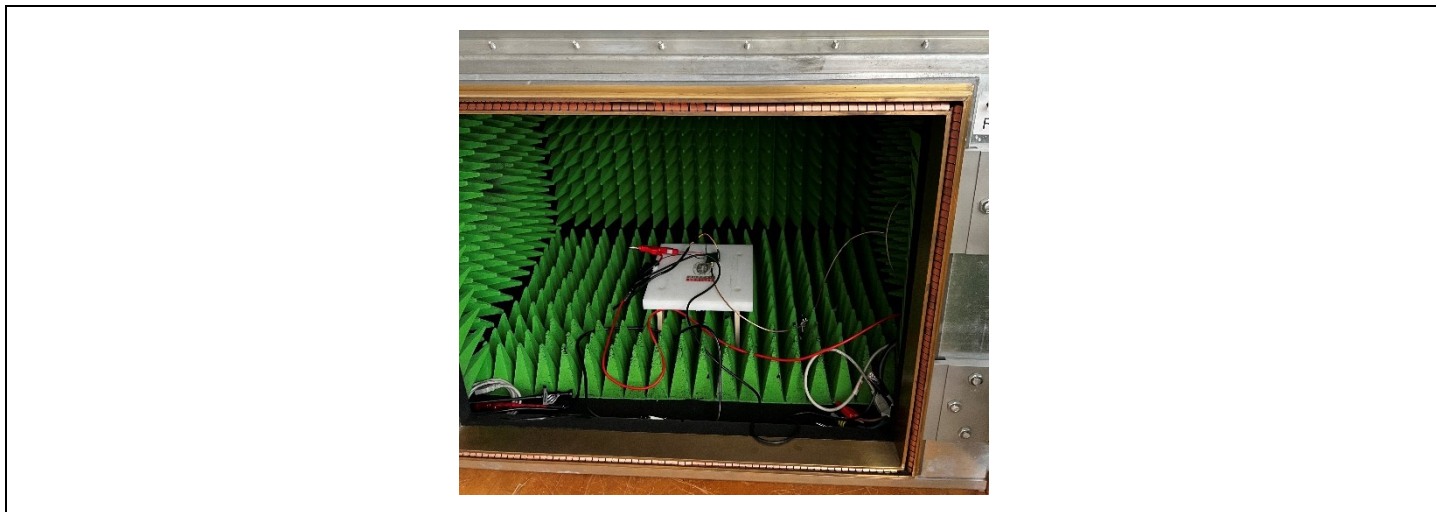

Photograph for 6dB emission bandwidth

4.3. LIMIT

The 6dB bandwidth shall be at least 500kHz

4.4. TEST EQUIPMENT LIST

TEST EQUIPMENT USED					
Description	Manufacturer	Model	Identifier	Cal_Date	Cal_Due
SOFT	LCIE SUD EST	LCIE FCC 247 (BLE_ZIGBEE...)	L2000059		
CABLE SMA 1m	RADIALL	18GHz	A5329862	04/21	04/23
Full Anechoic Room	SIEPEL	-	D3044024		
Multimeter - CEM	FLUKE	87	A1240251	03/21	03/23
Power supply DC	METRIX	AX503	A7042307		
SMA 1.5m	SUCOFLEX	18GHz	A5329863	04/21	04/22
Spectrum analyzer	ROHDE & SCHWARZ	FSV 40	A4060059	11/21	11/23
Thermo-hygrometer	TESTO	608-H1	B4204120	12/20	12/22
Thermo-hygrometer (PM1/2/3)	KIMO	HQ 210	B4206022	01/21	01/23
Splitter	JFW	50PD-292	A7132009	06/20	06/22
Attenuator 10dB	AEROFLEX	-	A7122269	09/20	03/22

Note: In our quality system, the test equipment calibration due is more & less 2 months



L C I E

4.5. RESULTS

1Mbits/s

6dB Emission Bandwidth

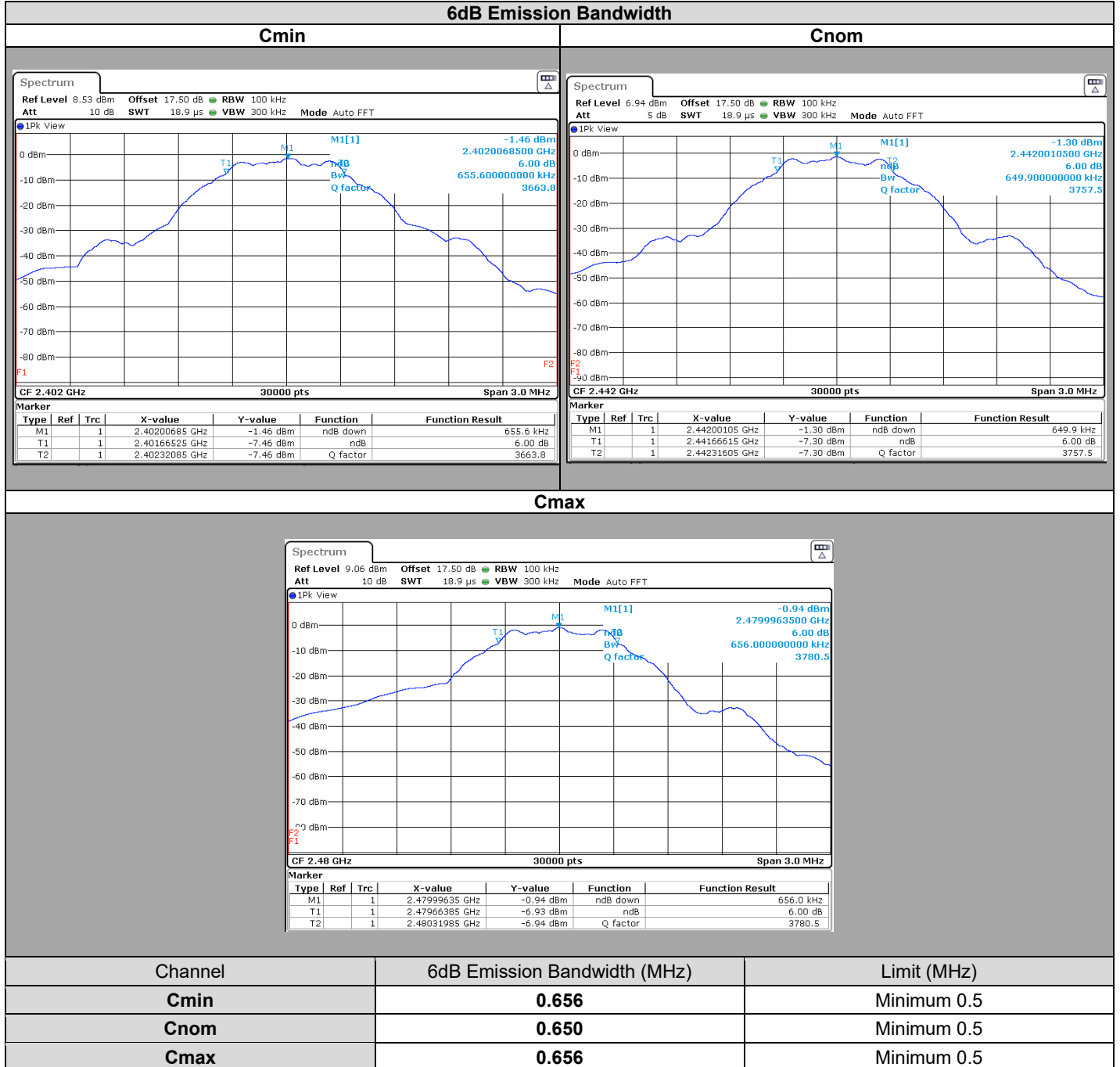

2Mbits/s

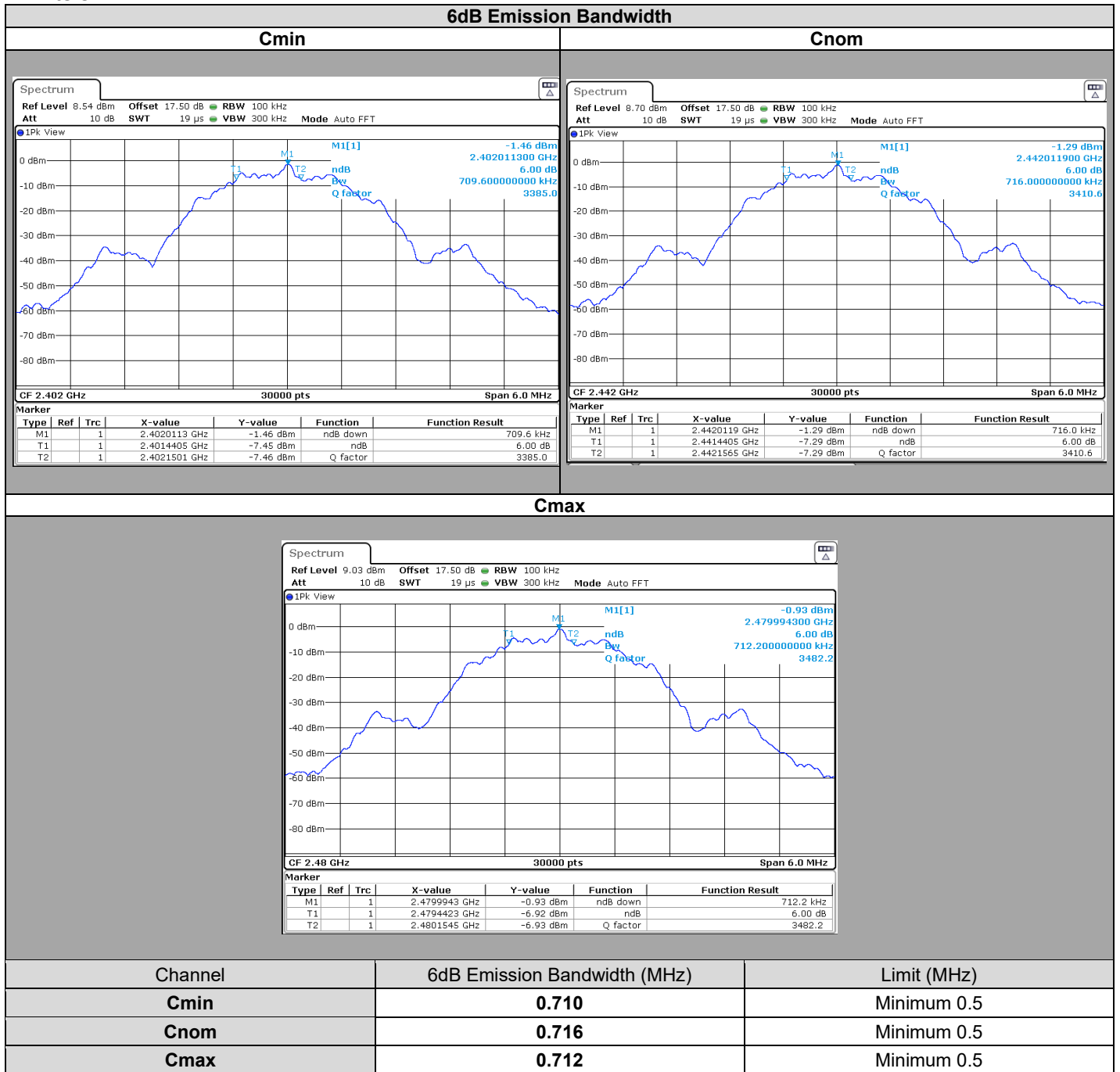

4.6. CONCLUSION

6dB Emission Bandwidth measurement performed on the sample of the product **STMICROELECTRONICS STM32WB5MMGH**, SN: **Sample RF**, in configuration and description presented in this test report, show levels **compliant** to the **47 CFR PART 15.247 & RSS 247** limits.



5. MAXIMUM CONDUCTED OUTPUT POWER

5.1. TEST CONDITIONS

Test performed by : Gaetan DESCHAMPS
Date of test : May 10, 2022
Ambient temperature : 25 °C
Relative humidity : 45 %

5.2. TEST SETUP

- The Equipment under Test is installed:

- On a table
- In an anechoic chamber

- Measurement is performed with a spectrum analyzer in:

- Conducted Method
- Radiated Method

- Test Procedure:

- KDB 558074 D01 DTS Meas Guidance v05r02 § 8.3.1.1

This procedure shall be used when the measurement instrument has available a resolution bandwidth that is greater than the DTS bandwidth.

- a) Set the RBW \geq DTS bandwidth.
- b) Set VBW \geq 3 x RBW.
- c) Set span \geq 3 x RBW
- d) Sweep time = auto couple.
- e) Detector = peak.
- f) Trace mode = max hold.
- g) Allow trace to fully stabilize.
- h) Use peak marker function to determine the peak amplitude level.

- KDB 558074 D01 DTS Meas Guidance v05r02 § 8.3.1.2

This procedure may be used when the maximum available RBW of the measurement instrument is less than the DTS bandwidth.

- a) Set the RBW = 1 MHz.
- b) Set the VBW \geq 3 x RBW
- c) Set the span \geq 1.5 x DTS bandwidth.
- d) Detector = peak.
- e) Sweep time = auto couple.
- f) Trace mode = max hold.
- g) Allow trace to fully stabilize.
- h) Use the instrument's band/channel power measurement function with the band limits set equal to the DTS bandwidth edges

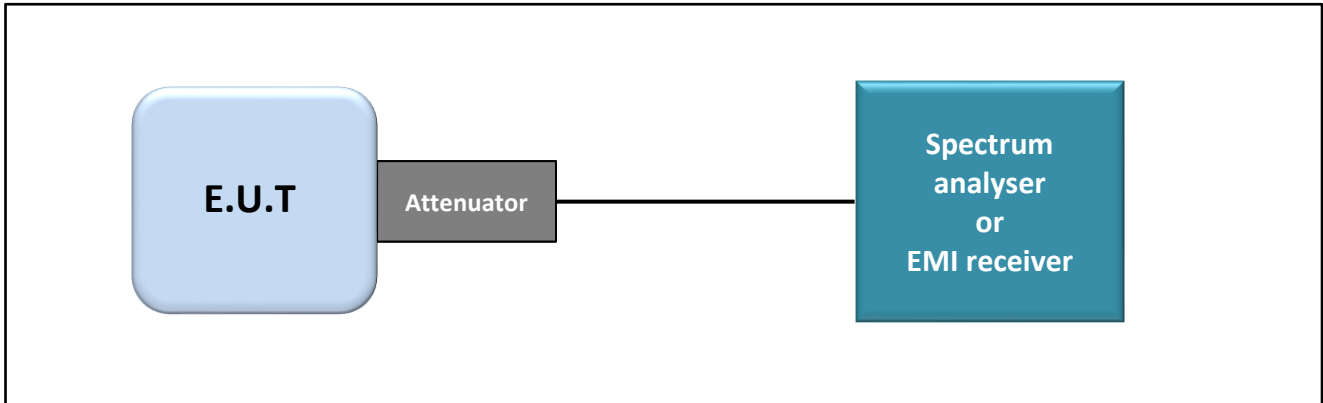

Test set up of Maximum Conducted Output Power

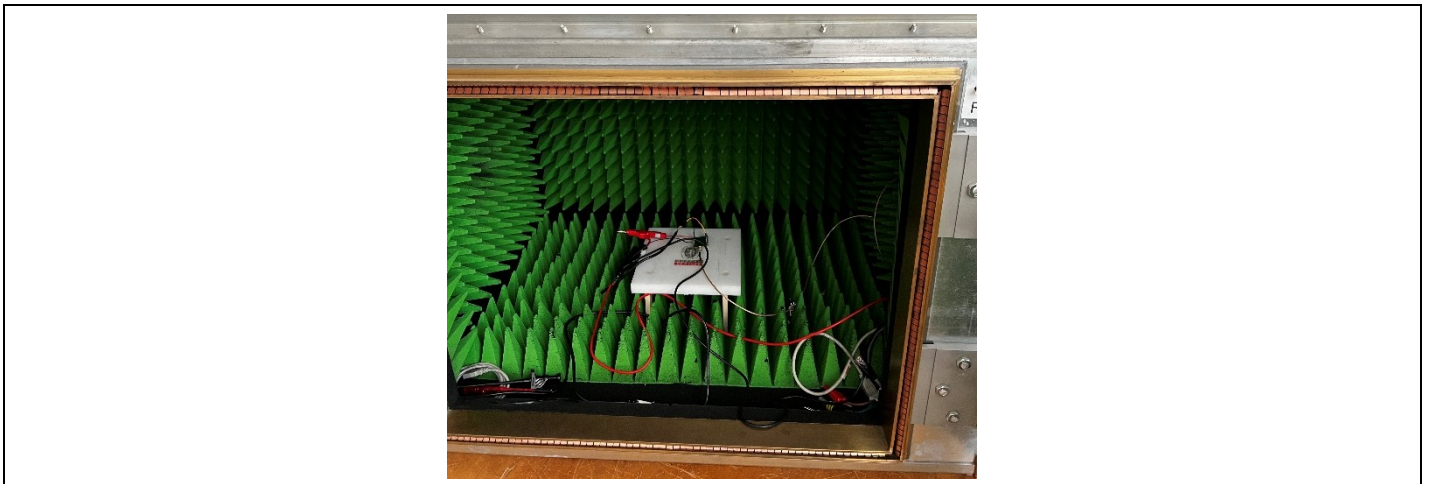

Photograph for Maximum Conducted Output Power

5.3. LIMIT

Maximum Conducted Output power:
2400MHz-2483.5MHz: Shall not exceed 30dBm
Limits are reduced by G-6dBi if Overall Antenna Gain above 6dBi



5.4. TEST EQUIPMENT LIST

TEST EQUIPMENT USED					
Description	Manufacturer	Model	Identifier	Cal_Date	Cal_Due
SOFT	LCIE SUD EST	LCIE FCC 247 (BLE_ZIGBEE...)	L2000059		
CABLE SMA 1m	RADIALL	18GHz	A5329862	04/21	04/23
Full Anechoic Room	SIEPEL	—	D3044024		
Multimeter - CEM	FLUKE	87	A1240251	03/21	03/23
Power supply DC	METRIX	AX503	A7042307		
SMA 1.5m	SUCOFLEX	18GHz	A5329863	04/21	04/22
Spectrum analyzer	ROHDE & SCHWARZ	FSV 40	A4060059	11/21	11/23
Thermo-hygrometer	TESTO	608-H1	B4204120	12/20	12/22
Thermo-hygrometer (PM1/2/3)	KIMO	HQ 210	B4206022	01/21	01/23
Splitter	JFW	50PD-292	A7132009	06/20	06/22
Attenuator 10dB	AEROFLEX	—	A7122269	09/20	03/22

Note: In our quality system, the test equipment calibration due is more & less 2 months

5.5. RESULTS

1Mbits/s

Maximum Conducted Output Power

Cmin

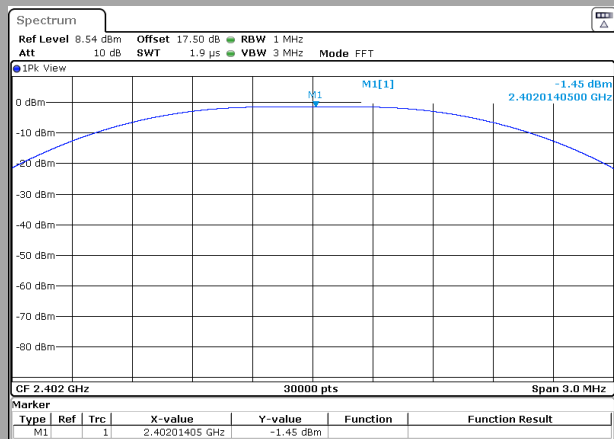

Cnom

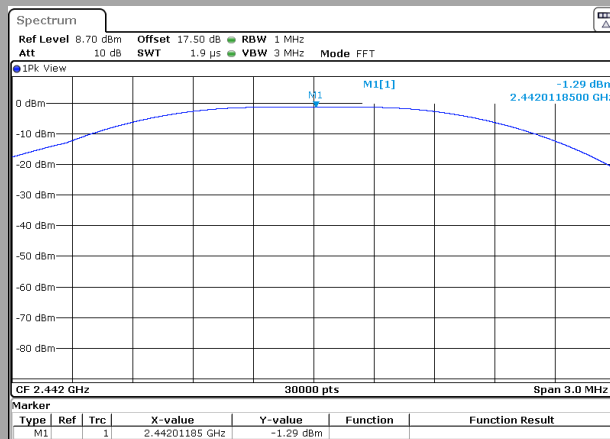

Cmax

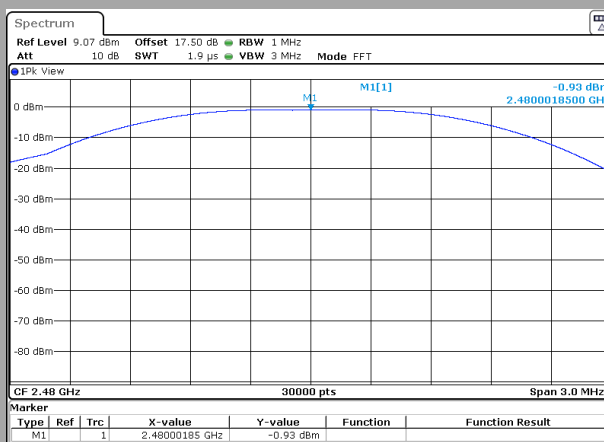

Channel	Offset Cable + Att (dB)	Antenna Gain (dBi)	Maximum Conducted Power (dBm)	Limit (dBm)
Cmin	17.5	1.9	-1.45	30. Reduced by G-6dBi if Antenna Gain above 6dBi
Cnom	17.5	1.9	-1.29	30. Reduced by G-6dBi if Antenna Gain above 6dBi
Cmax	17.5	1.9	-0.93	30. Reduced by G-6dBi if Antenna Gain above 6dBi

2Mbits/s

Maximum Conducted Output Power

Cmin

Cnom

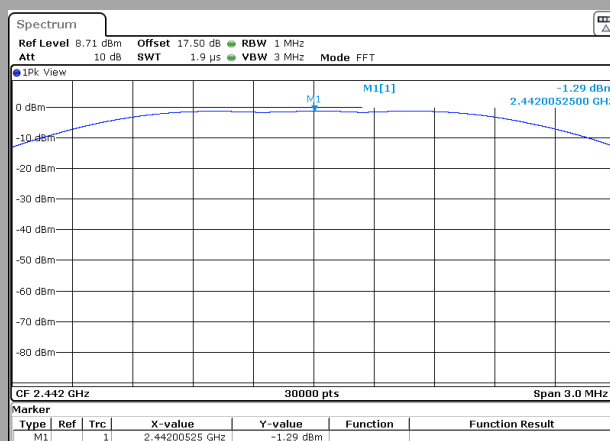
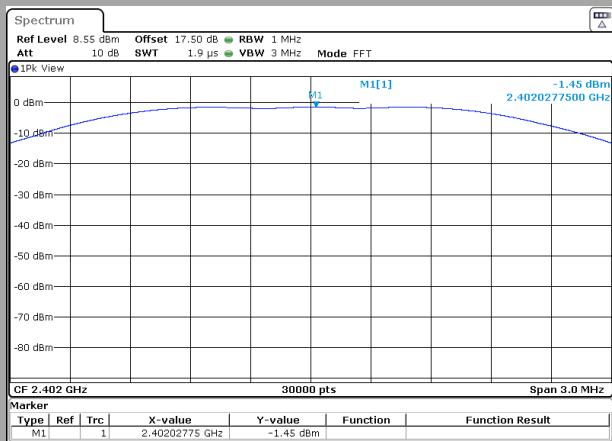

Cmax

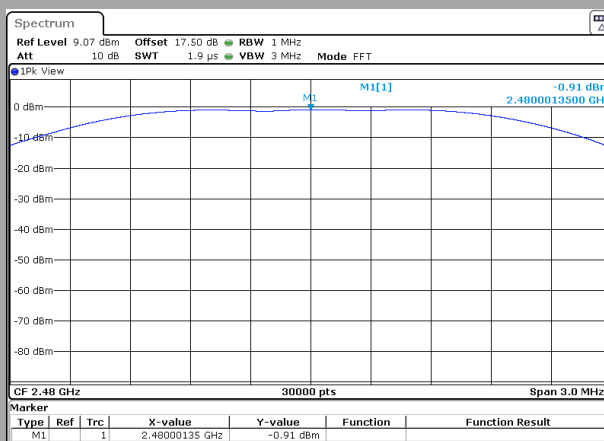

Channel	Offset Cable + Att (dB)	Antenna Gain (dBi)	Maximum Conducted Power (dBm)	Limit (dBm)
Cmin	17.5	1.9	-1.45	30. Reduced by G-6dBi if Antenna Gain above 6dBi
Cnom	17.5	1.9	-1.29	30. Reduced by G-6dBi if Antenna Gain above 6dBi
Cmax	17.5	1.9	-0.91	30. Reduced by G-6dBi if Antenna Gain above 6dBi

5.6. CONCLUSION

Maximum Conducted Output Power measurement performed on the sample of the product **STMICROELECTRONICS STM32WB5MMGH**, SN: **Sample RF**, in configuration and description presented in this test report, show levels **compliant** to the **47 CFR PART 15.247 & RSS 247** limits.

6. POWER SPECTRAL DENSITY

6.1. TEST CONDITIONS

Test performed by : Gaetan DESCHAMPS
Date of test : May 10, 2022
Ambient temperature : 25 °C
Relative humidity : 45 %

6.2. TEST SETUP

- The Equipment Under Test is installed:

- On a table
- In an anechoic chamber

- Measurement is performed with a spectrum analyzer in:

- Conducted Method
- Radiated Method

- Test Procedure:

- KDB 558074 D01 DTS Meas Guidance v05r02 § 8.4 (Method PKPSD)
 - a) Set analyzer center frequency to DTS channel center frequency.
 - b) Set the span to 1.5 times the DTS bandwidth.
 - c) Set the RBW to: 3 kHz.
 - d) Set the VBW $\geq 3 \times$ RBW.
 - e) Detector = peak.
 - f) Sweep time = auto couple.
 - g) Trace mode = max hold.
 - h) Allow trace to fully stabilize.
 - i) Use the peak marker function to determine the maximum amplitude level within the RBW.
 - j) If measured value exceeds limit, reduce RBW (no less than 3 kHz) and repeat.

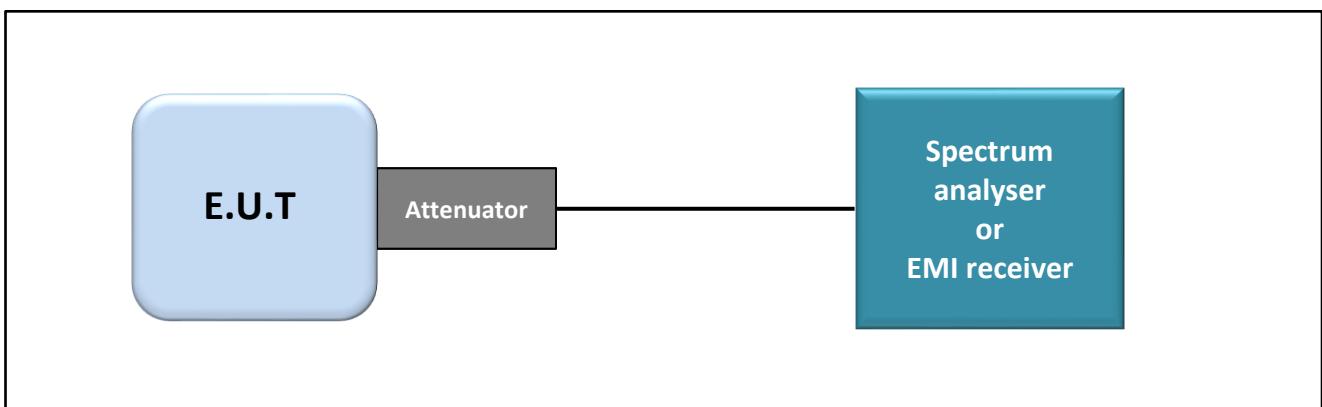

Test set up of Power Spectral Density

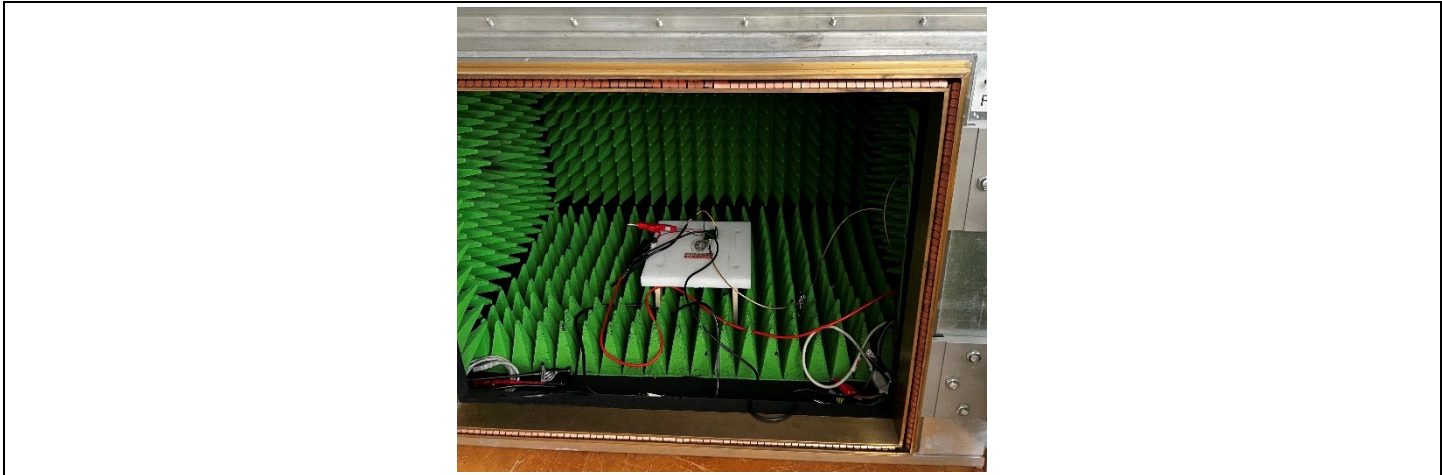

Photograph for Power Spectral Density

6.3. LIMIT

Power Spectral Density:
 2400MHz-2483.5MHz: Shall not exceed 8dBm/3kHz
 Limits are reduced by G-6dBi if Overall Antenna Gain above 6dBi

6.4. TEST EQUIPMENT LIST

TEST EQUIPMENT USED					
Description	Manufacturer	Model	Identifier	Cal_Date	Cal_Due
SOFT	LCIE SUD EST	LCIE FCC 247 (BLE_ZIGBEE...)	L2000059		
CABLE SMA 1m	RADIALL	18GHz	A5329862	04/21	04/23
Full Anechoic Room	SIEPEL	-	D3044024		
Multimeter - CEM	FLUKE	87	A1240251	03/21	03/23
Power supply DC	METRIX	AX503	A7042307		
SMA 1.5m	SUCOFLEX	18GHz	A5329863	04/21	04/22
Spectrum analyzer	ROHDE & SCHWARZ	FSV 40	A4060059	11/21	11/23
Thermo-hygrometer	TESTO	608-H1	B4204120	12/20	12/22
Thermo-hygrometer (PM1/2/3)	KIMO	HQ 210	B4206022	01/21	01/23
Splitter	JFW	50PD-292	A7132009	06/20	06/22
Attenuator 10dB	AEROFLEX	-	A7122269	09/20	03/22

Note: In our quality system, the test equipment calibration due is more & less 2 months



L C I E

6.5. RESULTS

1Mbits/s

Power Spectral Density

Cmin

Cnom

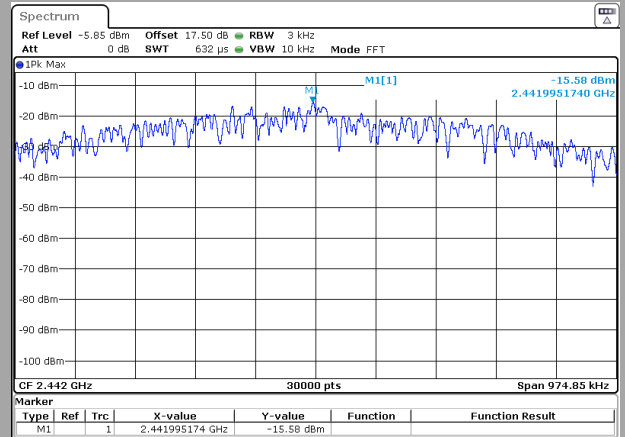
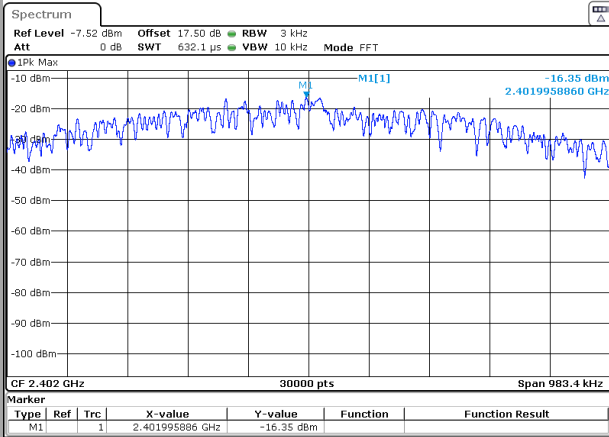

Cmax

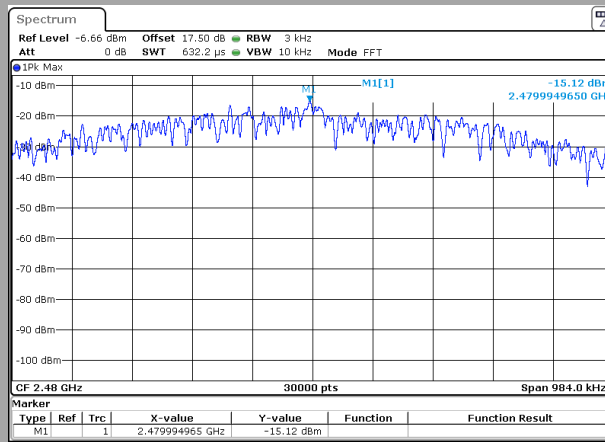

Channel	Offset Cable + Att (dB)	Antenna Gain (dBi)	Power Spectral Density (dBm/3kHz)	Limit (dBm/3kHz)
Cmin	17.5	1.9	-16.35	8. Reduced by G-6dBi if Antenna Gain above 6dBi
Cnom	17.5	1.9	-15.58	8. Reduced by G-6dBi if Antenna Gain above 6dBi
Cmax	17.5	1.9	-15.12	8. Reduced by G-6dBi if Antenna Gain above 6dBi

2Mbits/s

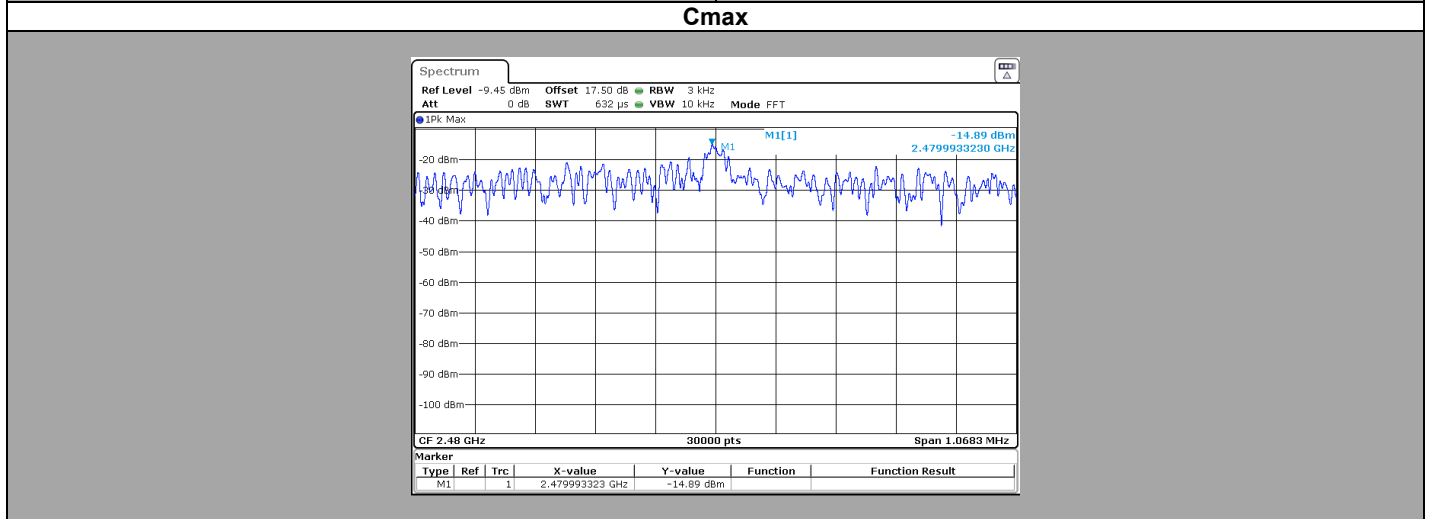
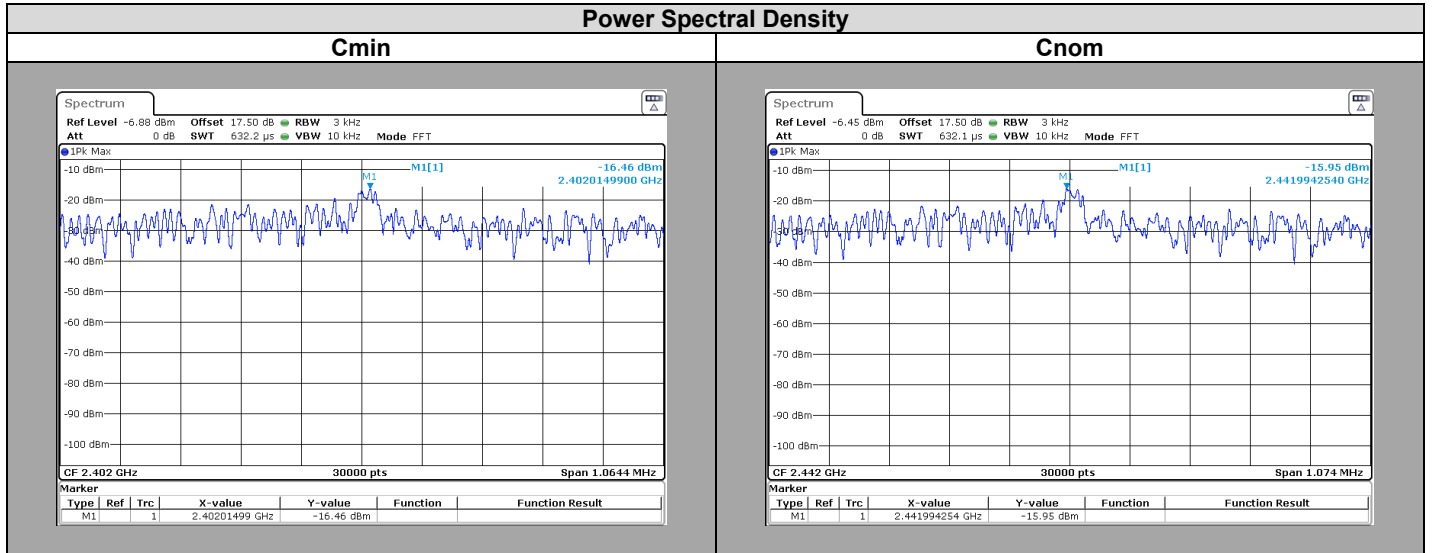

Channel	Offset Cable + Att (dB)	Antenna Gain (dBi)	Power Spectral Density (dBm/3kHz)	Limit (dBm/3kHz)
Cmin	17.5	1.9	-16.46	8. Reduced by G-6dBi if Antenna Gain above 6dBi
Cnom	17.5	1.9	-15.95	8. Reduced by G-6dBi if Antenna Gain above 6dBi
Cmax	17.5	1.9	-14.89	8. Reduced by G-6dBi if Antenna Gain above 6dBi

6.6. CONCLUSION

Power Spectral Density measurement performed on the sample of the product **STMICROELECTRONICS STM32WB5MMGH**, SN: **Sample RF**, in configuration and description presented in this test report, show levels **compliant** to the **47 CFR PART 15.247 & RSS 247** limits.

7. UNWANTED EMISSIONS INTO NON-RESTRICTED FREQUENCY BANDS AT THE BAND EDGE

7.1. TEST CONDITIONS

Test performed by : Gaetan DESCHAMPS
Date of test : May 10, 2022
Ambient temperature : 25 °C
Relative humidity : 45 %

7.2. TEST SETUP

- The Equipment Under Test is installed:
 - On a table
 - In an anechoic chamber
- Measurement is performed with a spectrum analyzer in:
 - Conducted Method
 - Radiated Method
- Test Procedure:
 - KDB 558074 D01 DTS Meas Guidance v05r02 § 8.5

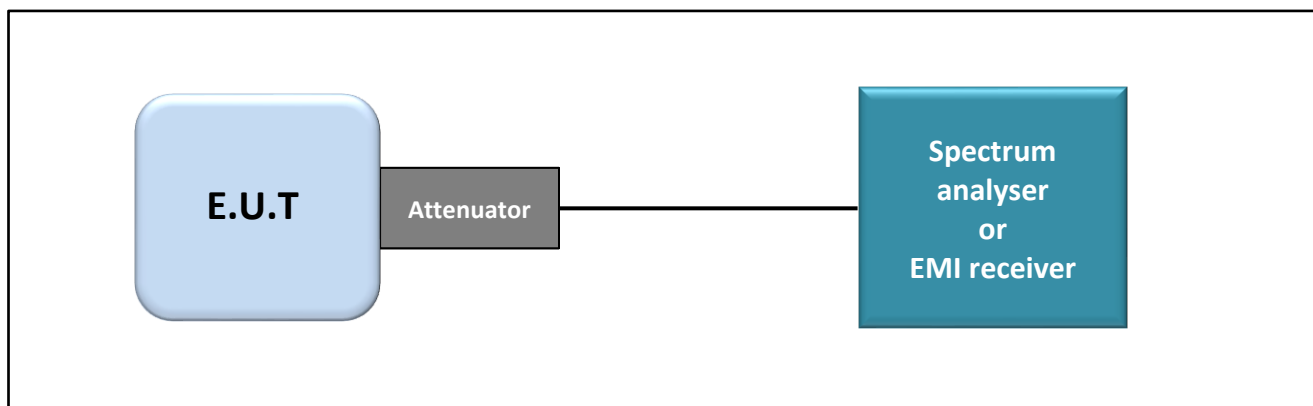

Test set up of Unwanted Emissions into Non-Restricted Frequency Bands at the Band Edge

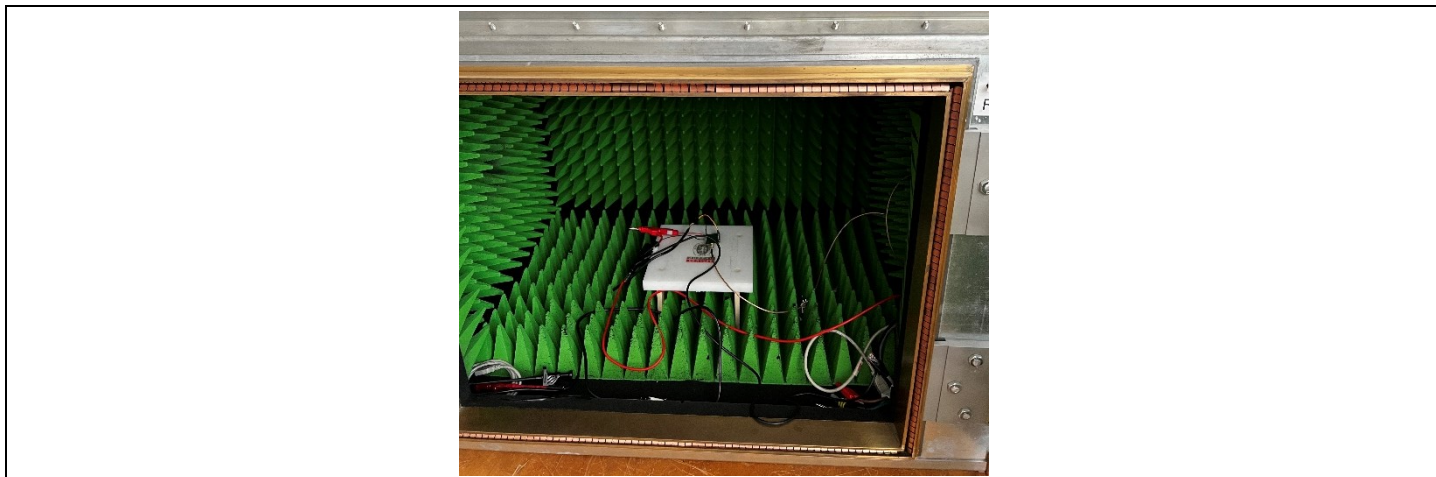

Photograph for Unwanted Emission into non-restricted frequency bands at the band edge

7.3. LIMIT

All Spurious Emissions must be at least 20dB below the Fundamental Radiator Level at the Band Edge Edge “2400MHz & 2483,5MHz”

7.4. TEST EQUIPMENT LIST

TEST EQUIPMENT USED					
Description	Manufacturer	Model	Identifier	Cal_Date	Cal_Due
SOFT	LCIE SUD EST	LCIE FCC 247 (BLE_ZIGBEE...)	L2000059		
CABLE SMA 1m	RADIALL	18GHz	A5329862	04/21	04/23
Full Anechoic Room	SIEPEL	–	D3044024		
Multimeter - CEM	FLUKE	87	A1240251	03/21	03/23
Power supply DC	METRIX	AX503	A7042307		
SMA 1.5m	SUCOFLEX	18GHz	A5329863	04/21	04/22
Spectrum analyzer	ROHDE & SCHWARZ	FSV 40	A4060059	11/21	11/23
Thermo-hygrometer	TESTO	608-H1	B4204120	12/20	12/22
Thermo-hygrometer (PM1/2/3)	KIMO	HQ 210	B4206022	01/21	01/23
Splitter	JFW	50PD-292	A7132009	06/20	06/22
Attenuator 10dB	AEROFLEX	–	A7122269	09/20	03/22

Note: In our quality system, the test equipment calibration due is more & less 2 months



L C I E

7.5. RESULTS

1Mbits/s

Cmin/Cnom/Cmax

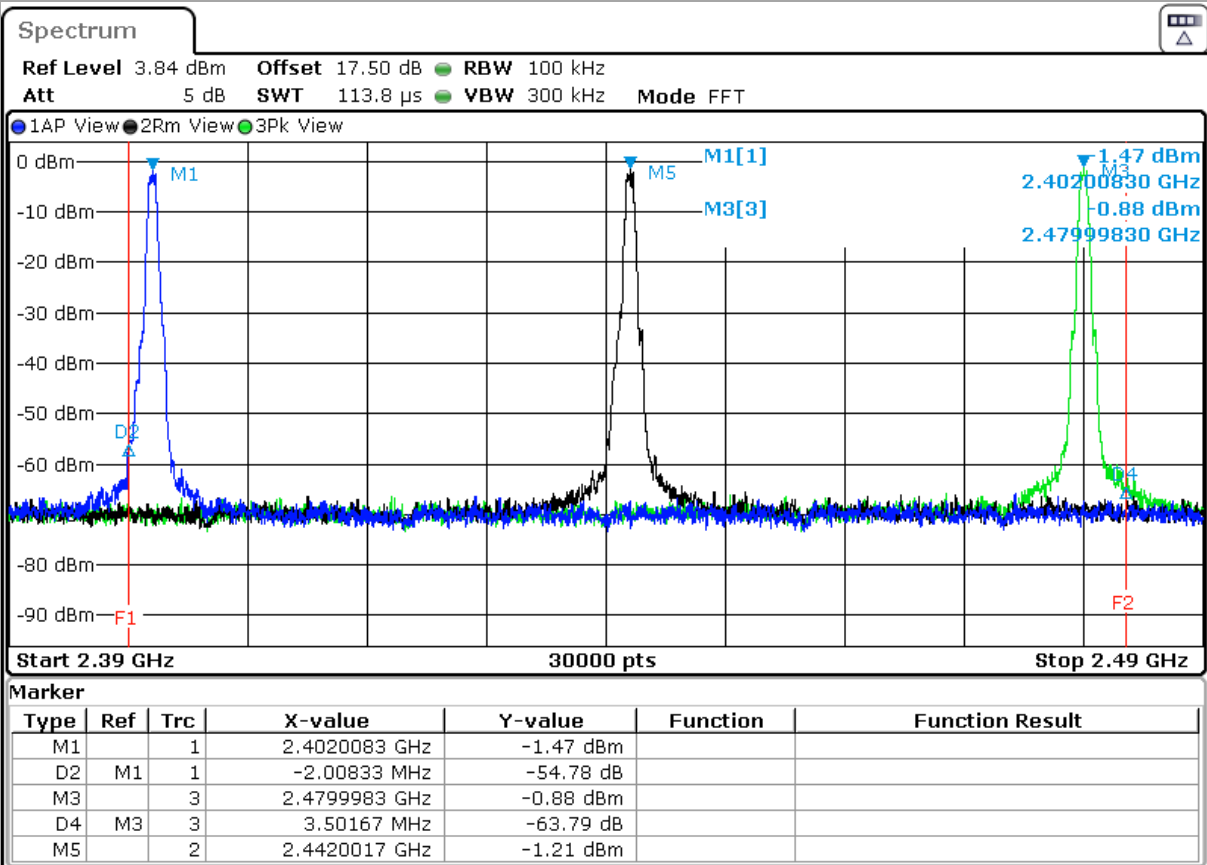

Frequency (MHz)	Level (dBc)	Limit (dBc)
2400	-54.78	20
2483.5	-63.79	20



L C I E

2Mbits/s

Cmin/Cnom/Cmax

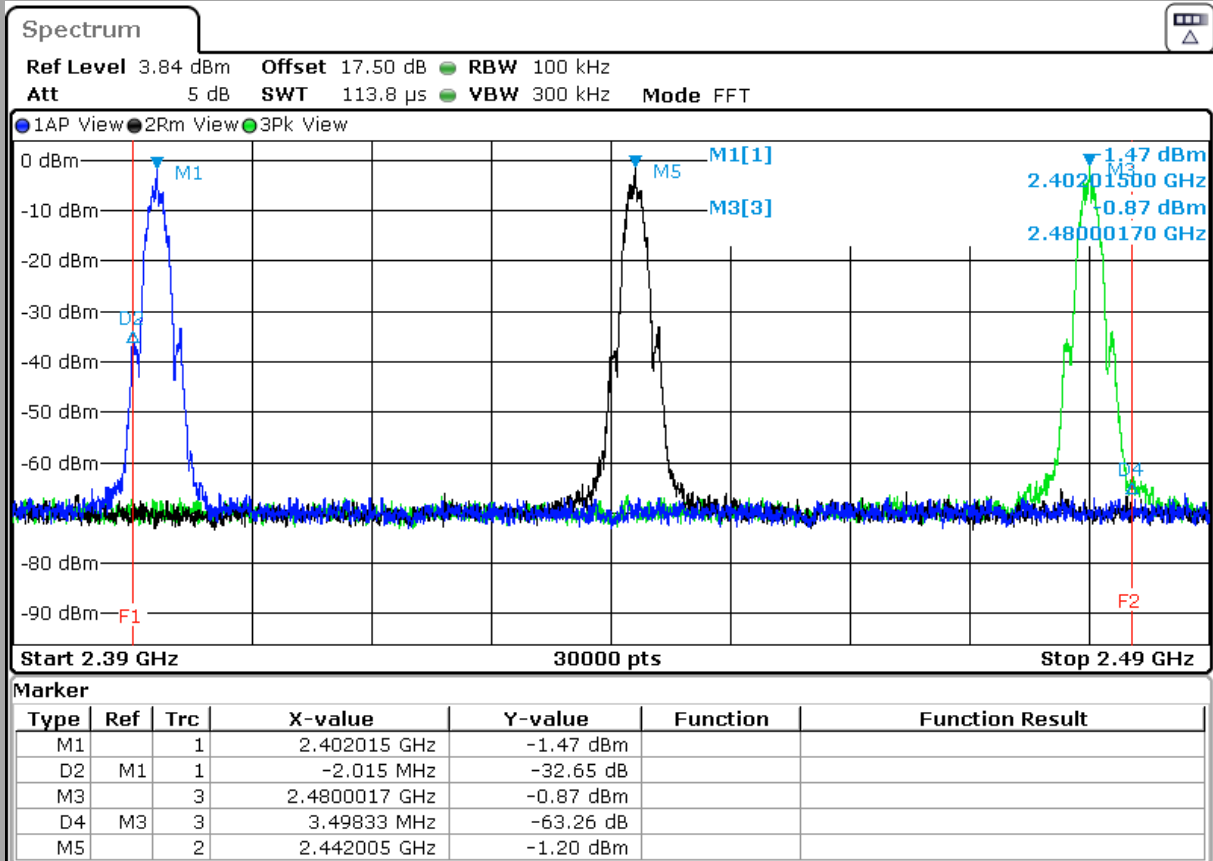

Frequency (MHz)	Level (dBc)	Limit (dBc)
2400	-32.65	20
2483.5	-63.26	20

7.6. CONCLUSION

Unwanted Emission into non-restricted frequency bands at the band edge measurement performed on the sample of the product **STMICROELECTRONICS STM32WB5MMGH**, SN: **Sample RF** , in configuration and description presented in this test report, show levels **compliant** to the **47 CFR PART 15.247 & RSS 247** limits.

8. UNWANTED EMISSIONS INTO NON-RESTRICTED FREQUENCY BANDS

8.1. TEST CONDITIONS

Test performed by : Gaetan DESCHAMPS
Date of test : May 10, 2022
Ambient temperature : 25 °C
Relative humidity : 45 %

8.2. TEST SETUP

- The Equipment under Test is installed:

- On a table
- In an anechoic chamber

- Measurement is performed with a spectrum analyzer in:

- Conducted Method
- Radiated Method

- Test Procedure:

- KDB 558074 D01 DTS Meas Guidance v05r02 § 8.5

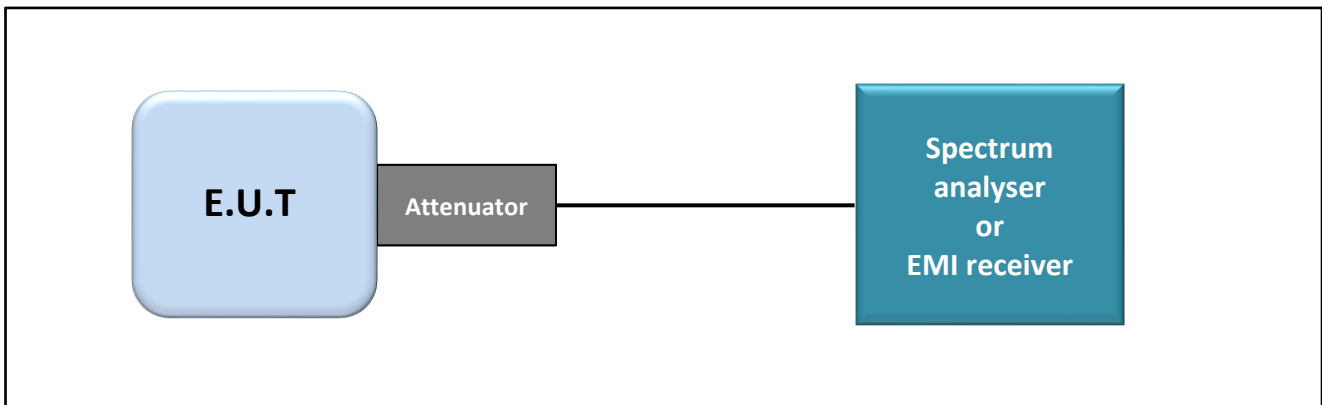

Test set up of Unwanted Emissions into Non-Restricted Frequency Bands

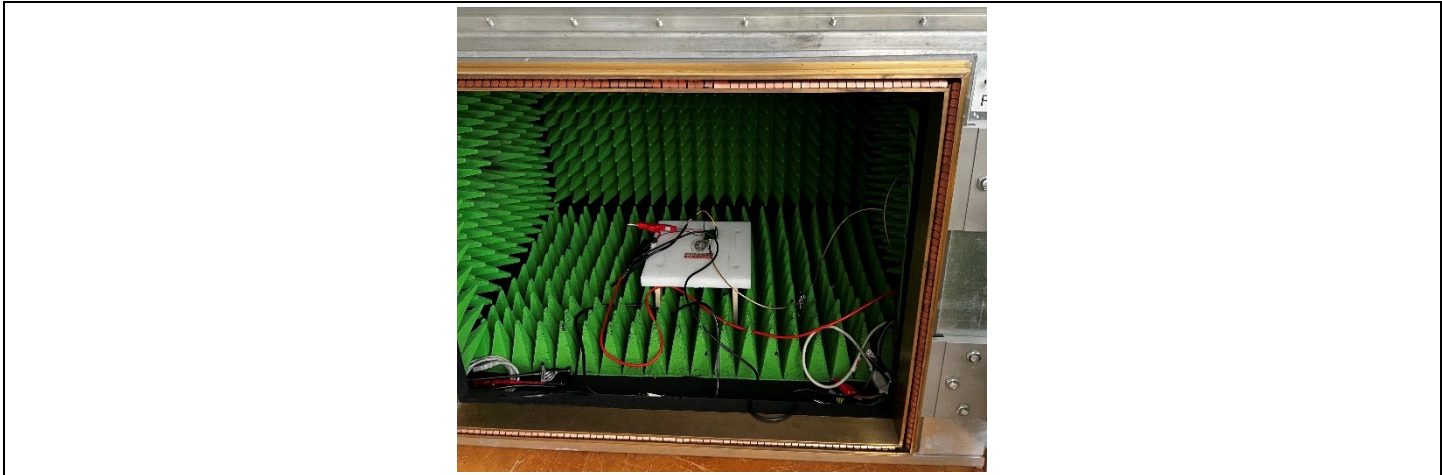

Photograph for Unwanted Emission into non-restricted frequency bands

8.3. LIMIT

All Spurious Emissions must be at least 20 below the Fundamental Radiator Level

8.4. TEST EQUIPMENT LIST

TEST EQUIPMENT USED					
Description	Manufacturer	Model	Identifier	Cal_Date	Cal_Due
CABLE SMA 1m	RADIALL	18GHz	A5329862	04/21	04/23
Full Anechoic Room	SIEPEL	-	D3044024		
Multimeter - CEM	FLUKE	87	A1240251	03/21	03/23
Power supply DC	METRIX	AX503	A7042307		
SMA 1.5m	SUCOFLEX	18GHz	A5329863	04/21	04/22
Spectrum analyzer	ROHDE & SCHWARZ	FSV 40	A4060059	11/21	11/23
Thermo-hygrometer	TESTO	608-H1	B4204120	12/20	12/22
Thermo-hygrometer (PM1/2/3)	KIMO	HQ 210	B4206022	01/21	01/23
Splitter	JFW	50PD-292	A7132009	06/20	06/22
Attenuator 10dB	AEROFLEX	-	A7122269	09/20	03/22
BAT EMC	NEXIO	v3.21.0.27	L1000115		

Note: In our quality system, the test equipment calibration due is more & less 2 months

8.5. RESULTS

1Mbits/s

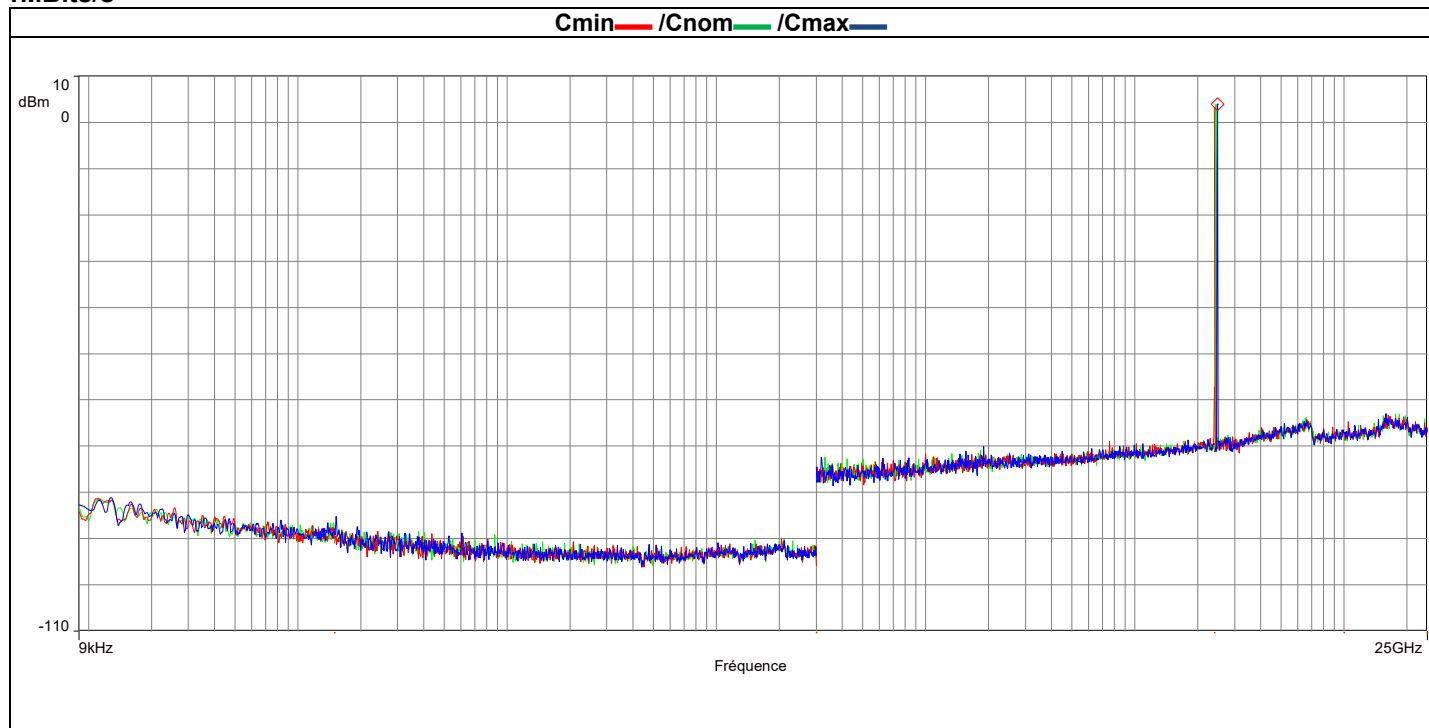

Frequency (MHz)	Level (dBm)	Level (dBc)	Limit (dBc)
2402.00	3.34		
2442.00	3.99		
2480.00	3.94		

2Mbits/s

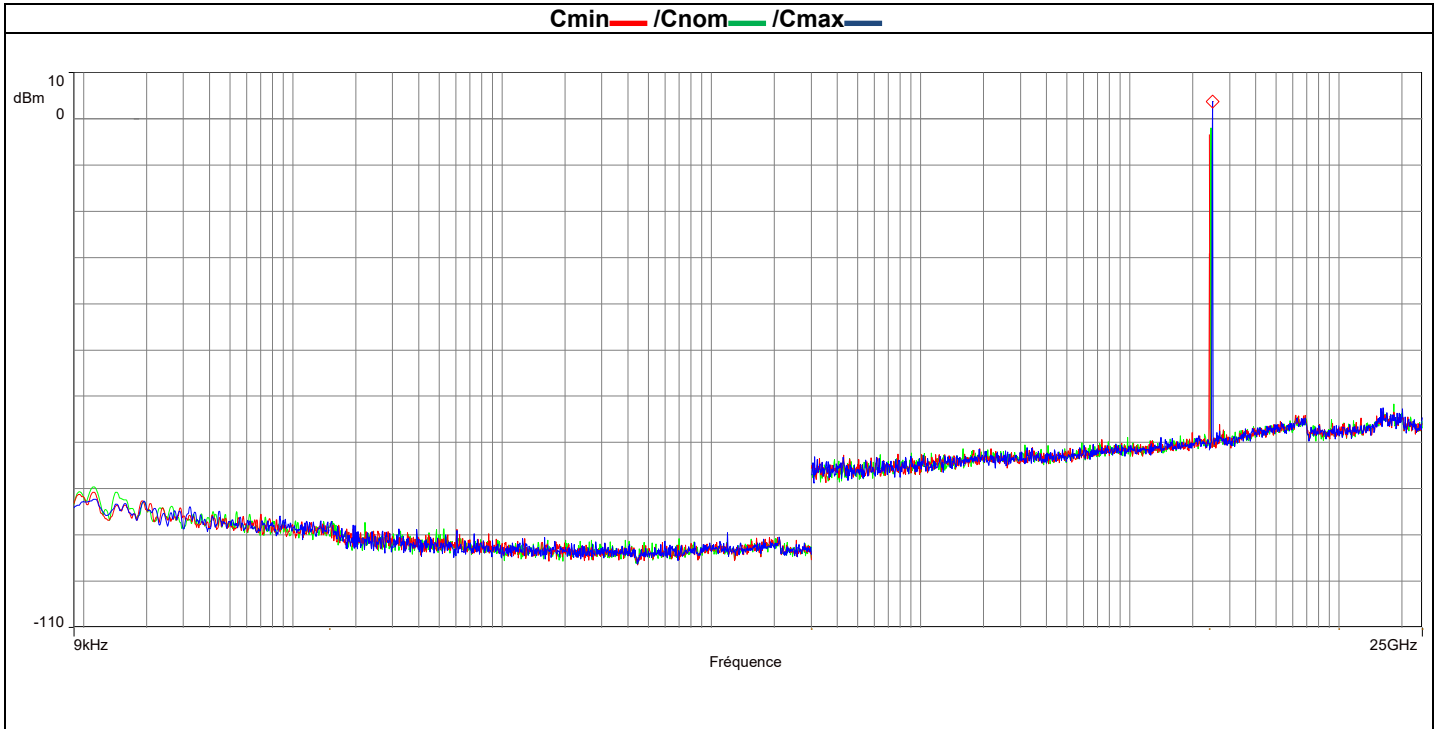

Frequency (MHz)	Level (dBm)	Level (dBc)	Limit (dBc)
2402.00	3.34		
2442.00	3.99		
2480.00	3.94		

8.6. CONCLUSION

Unwanted Emission into non-restricted frequency bands measurement performed on the sample of the product **STMICROELECTRONICS STM32WB5MMGH**, SN: **Sample RF** , in configuration and description presented in this test report, show levels **compliant** to the **47 CFR PART 15.247 & RSS 247** limits.

9. AC POWER LINE CONDUCTED EMISSIONS

9.1. TEST CONDITIONS

Test performed by : Gaetan DESCHAMPS
 Date of test : May 12, 2022
 Ambient temperature : 24 °C
 Relative humidity : 41 %

9.2. TEST SETUP

The product has been tested according to ANSI C63.10 (2013) method. The EUT is placed on the ground reference plane, at 80cm from the LISN. The distance between the EUT and the vertical ground plane is 40cm. Auxiliaries are powered by another LISN. The cable has been shorted to 1meter length. The EUT is powered through the LISN. Measurement is made with a receiver in peak mode. This was followed by a Quasi-Peak, i.e. CISPR measurement for any strong signal. If the average limit is met when using a Quasi-Peak detector, the EUT shall be deemed to meet both limits and measurement with the average detector is unnecessary. The LISN (measure) is 50Ω / 50μH. Interconnecting cables and equipment's were moved to position that maximized emission.

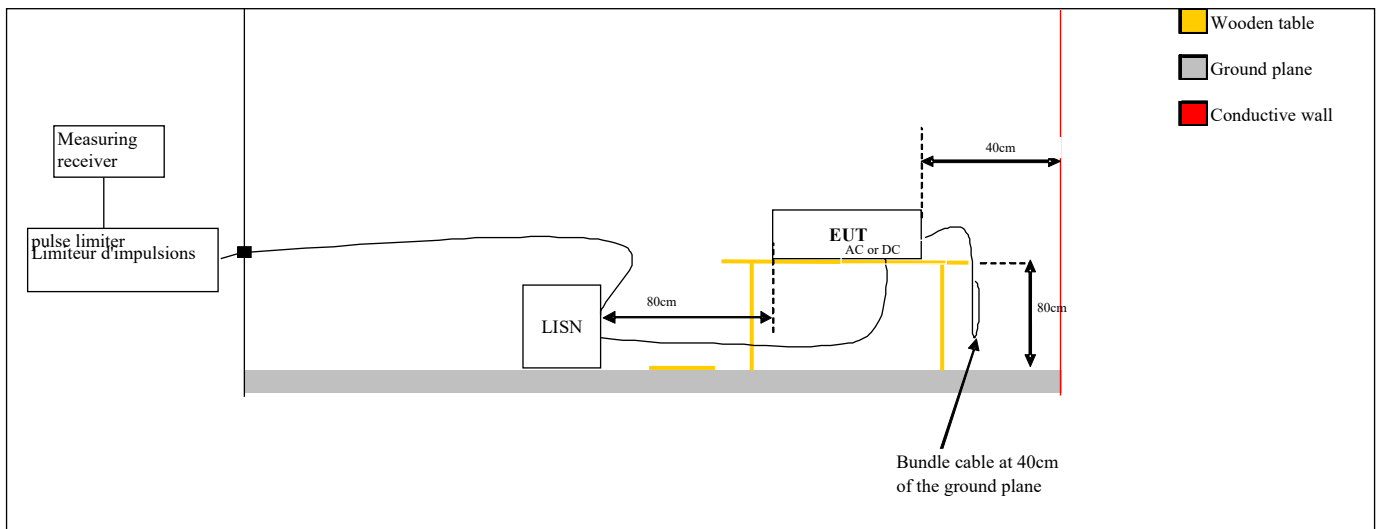

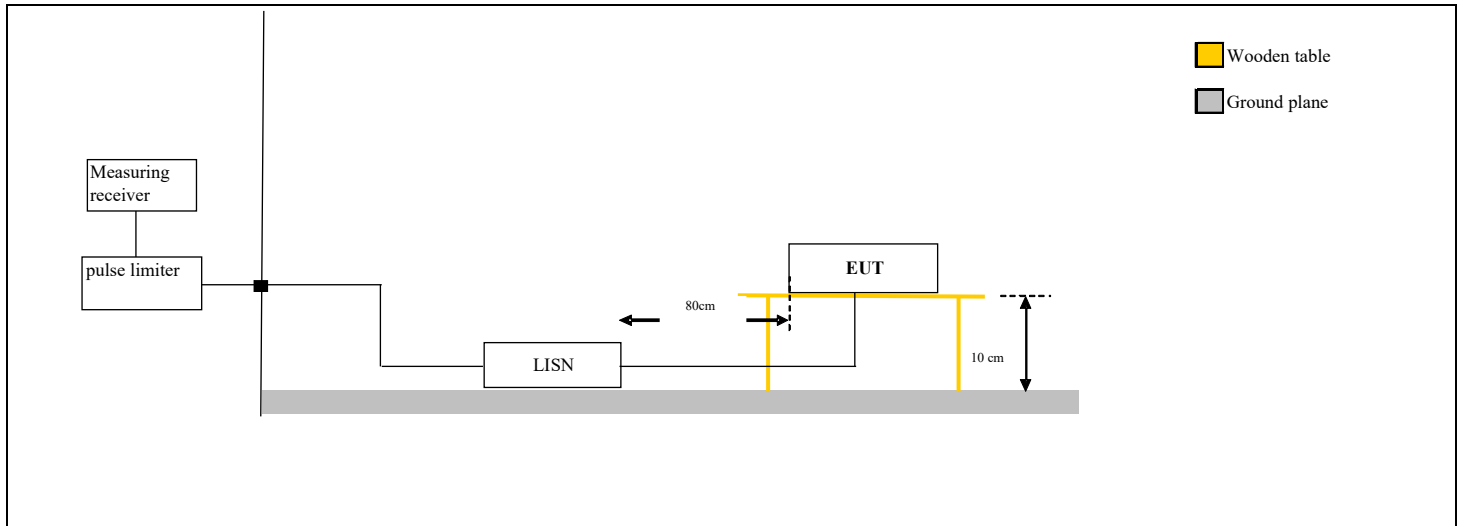

Test set up of AC Power Line Conducted Emissions

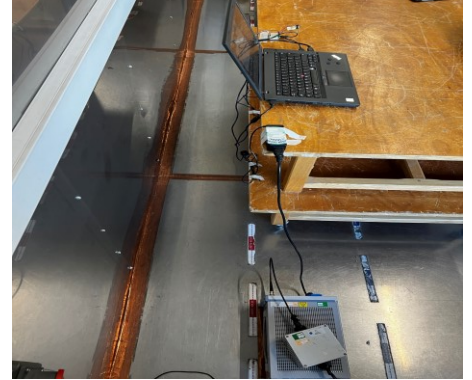
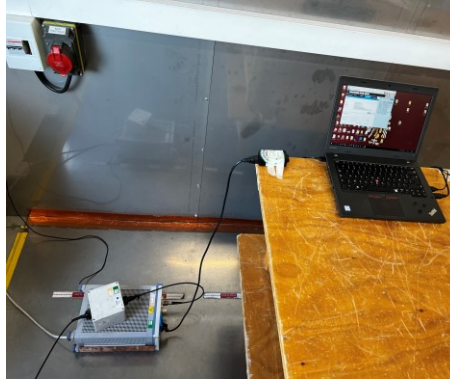

Test setup with Laptop

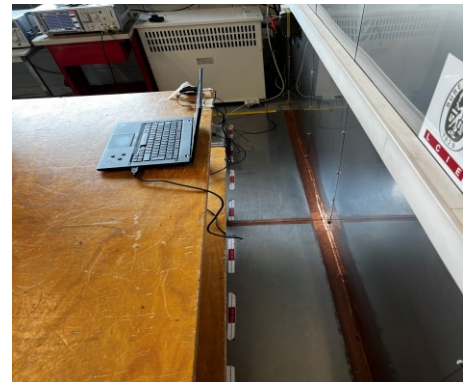
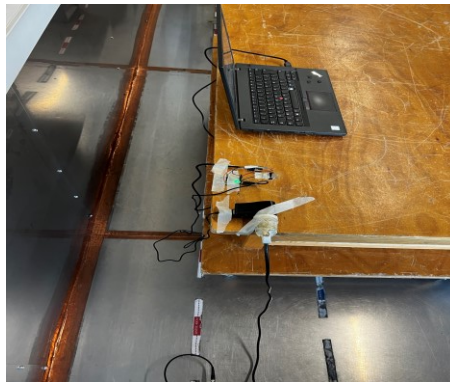

Test setup with Power Supply

Photograph for AC Power Line Conducted Emissions

9.3. LIMIT

Frequency range	Level	Detector
0,15kHz to 0,5MHz	66dB μ V to 56 μ V*	QPeak
	56dB μ V to 46 μ V*	Average
0,5MHz to 5MHz	56dB μ V	QPeak
	46dB μ V	Average
5MHz to 30MHz	60B μ V	QPeak
	50dB μ V	Average

*Decreases with the logarithm of the frequency



9.4. TEST EQUIPMENT LIST

TEST EQUIPMENT USED					
Description	Manufacturer	Model	Identifier	Cal_Date	Cal_Due
BAT EMC	NEXIO	v3.21.0.27	L1000115		
Cable + self	–	–	A5329578	05/22	05/23
EMC comb generator	LCIE SUD EST	–	A3169098		
LISN	ROHDE & SCHWARZ	ENV216	C2320291	08/21	08/22
Spectrum Analyzer 9kHz - 30MHz	ROHDE & SCHWARZ	ESHS10	A2642028	01/20	05/22
Thermo-hygrometer (PM1/2/3)	KIMO	HQ 210	B4206022	01/21	01/23
Transient limiter	ROHDE & SCHWARZ	ESH3-Z2	A7122204	08/20	08/22
Receiver 20Hz – 8GHz	ROHDE & SCHWARZ	ESU8	A2642019	10/20	10/22

Note: In our quality system, the test equipment calibration due is more & less 2 months

9.5. DIVERGENCE, ADDITION OR SUPPRESSION ON THE TEST SPECIFICATION

None Divergence:



L C I E

9.6. RESULTS

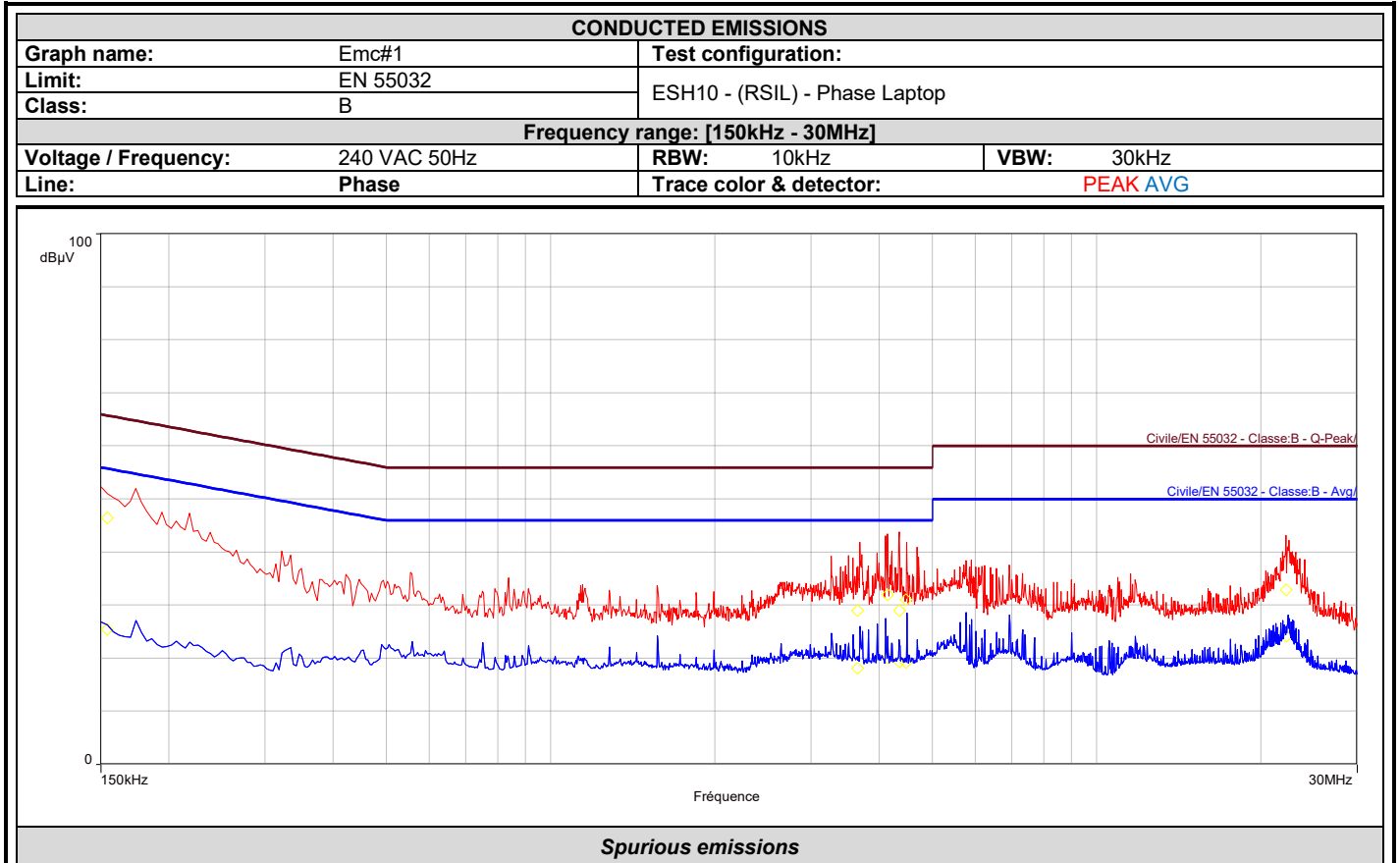

Frequency (MHz)	Q-Peak (dBµV)	Lim.Q-Peak (dBµV)	Q-Peak-Lim.Q-Peak (dB)	Avg (dBµV)	Lim.Avg (dBµV)	Avg-Lim.Avg (dB)	Correction (dB)
0.154	46.4	65.8	-19.3	25.5	55.8	-30.3	19.4
3.648	29.0	56.0	-27.0	18.1	46.0	-27.9	19.8
4.140	32.0	56.0	-24.0	20.1	46.0	-25.9	19.8
4.356	29.0	56.0	-27.0	19.4	46.0	-26.6	19.8
4.472	31.0	56.0	-25.0	19.2	46.0	-26.8	19.8
22.220	32.9	60.0	-27.1	24.2	50.0	-25.8	21.0



L C I E

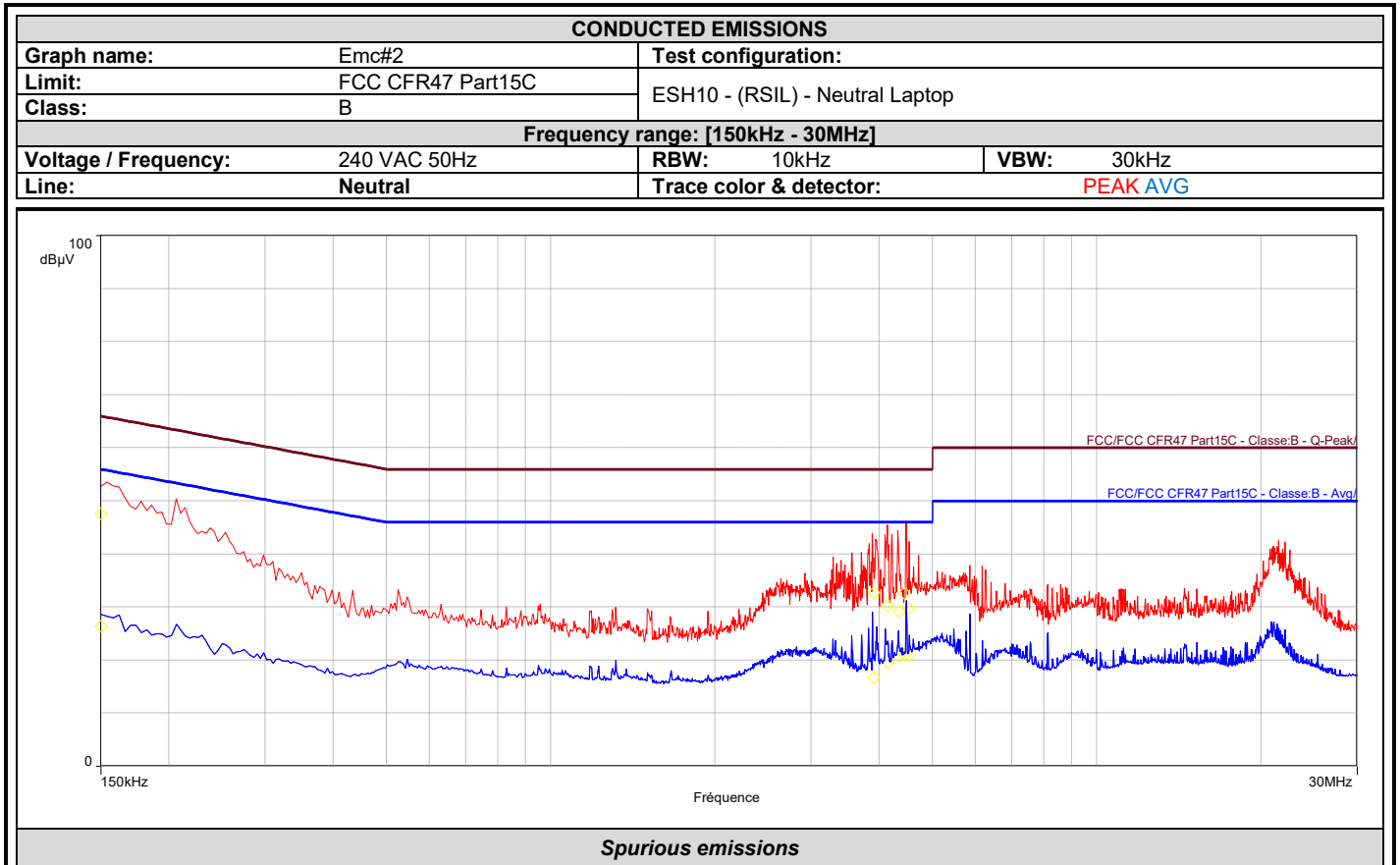

Frequency (MHz)	Q-Peak (dBµV)	Lim.Q-Peak (dBµV)	Q-Peak-Lim.Q-Peak (dB)	Avg (dBµV)	Lim.Avg (dBµV)	Avg-Lim.Avg (dB)	Correction (dB)
0.150	47.6	66.0	-18.4	26.4	56.0	-29.6	19.4
3.908	32.8	56.0	-23.2	16.8	46.0	-29.2	19.8
4.148	30.3	56.0	-25.7	19.5	46.0	-26.5	19.8
4.344	29.2	56.0	-26.8	20.7	46.0	-25.3	19.8
4.448	32.6	56.0	-23.4	21.1	46.0	-24.9	19.8
4.532	29.7	56.0	-26.3	20.9	46.0	-25.1	19.8



L C I E

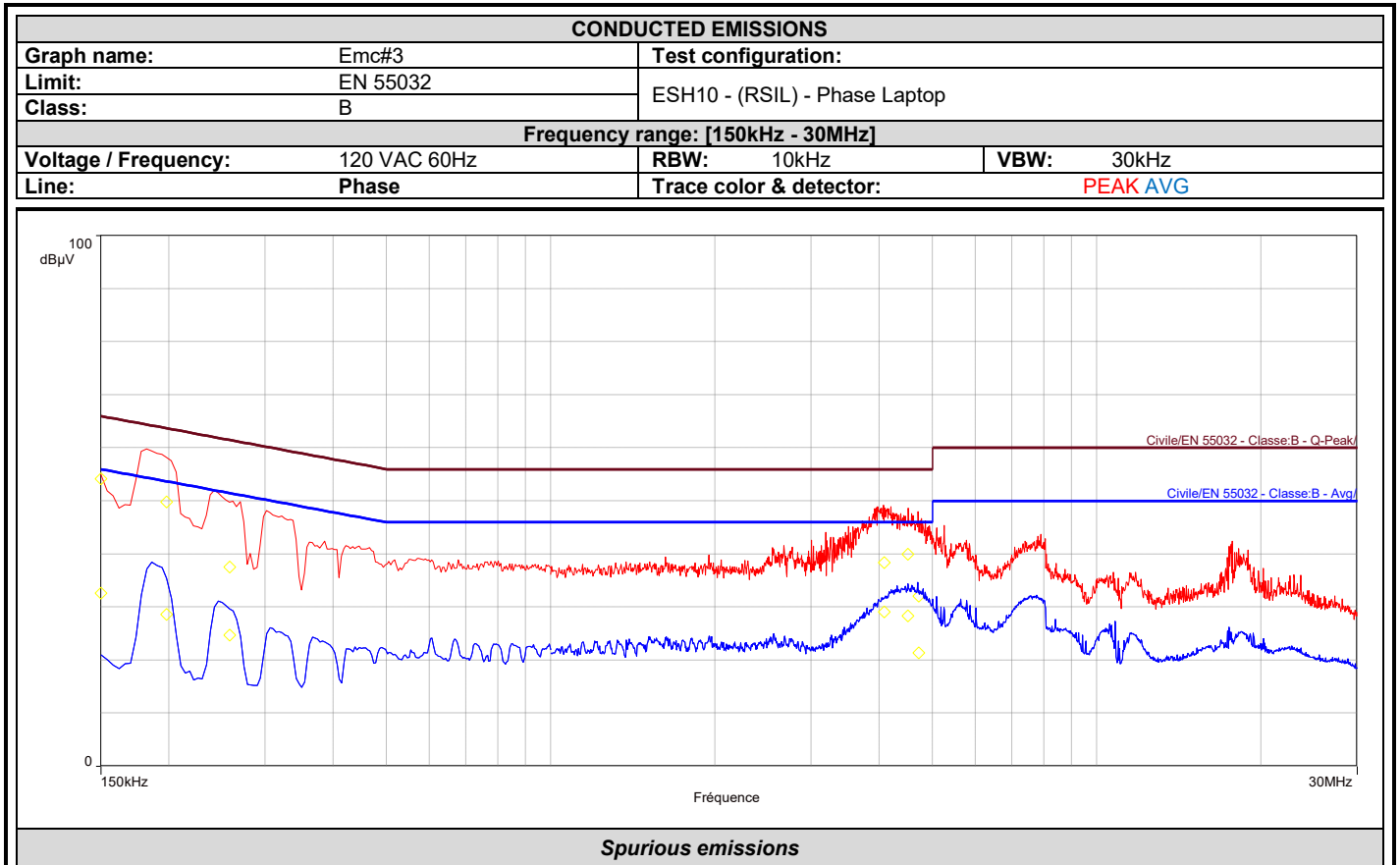

Frequency (MHz)	Q-Peak (dBµV)	Lim.Q-Peak (dBµV)	Q-Peak-Lim.Q-Peak (dB)	Avg (dBµV)	Lim.Avg (dBµV)	Avg-Lim.Avg (dB)	Correction (dB)
0.150	54.2	66.0	-11.8	32.6	56.0	-23.4	19.4
0.198	49.8	63.7	-13.9	28.7	53.7	-25.0	19.6
0.258	37.6	61.5	-23.9	24.7	51.5	-26.8	19.5
4.084	38.4	56.0	-17.6	29.1	46.0	-16.9	19.8
4.508	40.0	56.0	-16.0	28.4	46.0	-17.6	19.8
4.724	32.0	56.0	-24.0	21.4	46.0	-24.6	19.8



L C I E

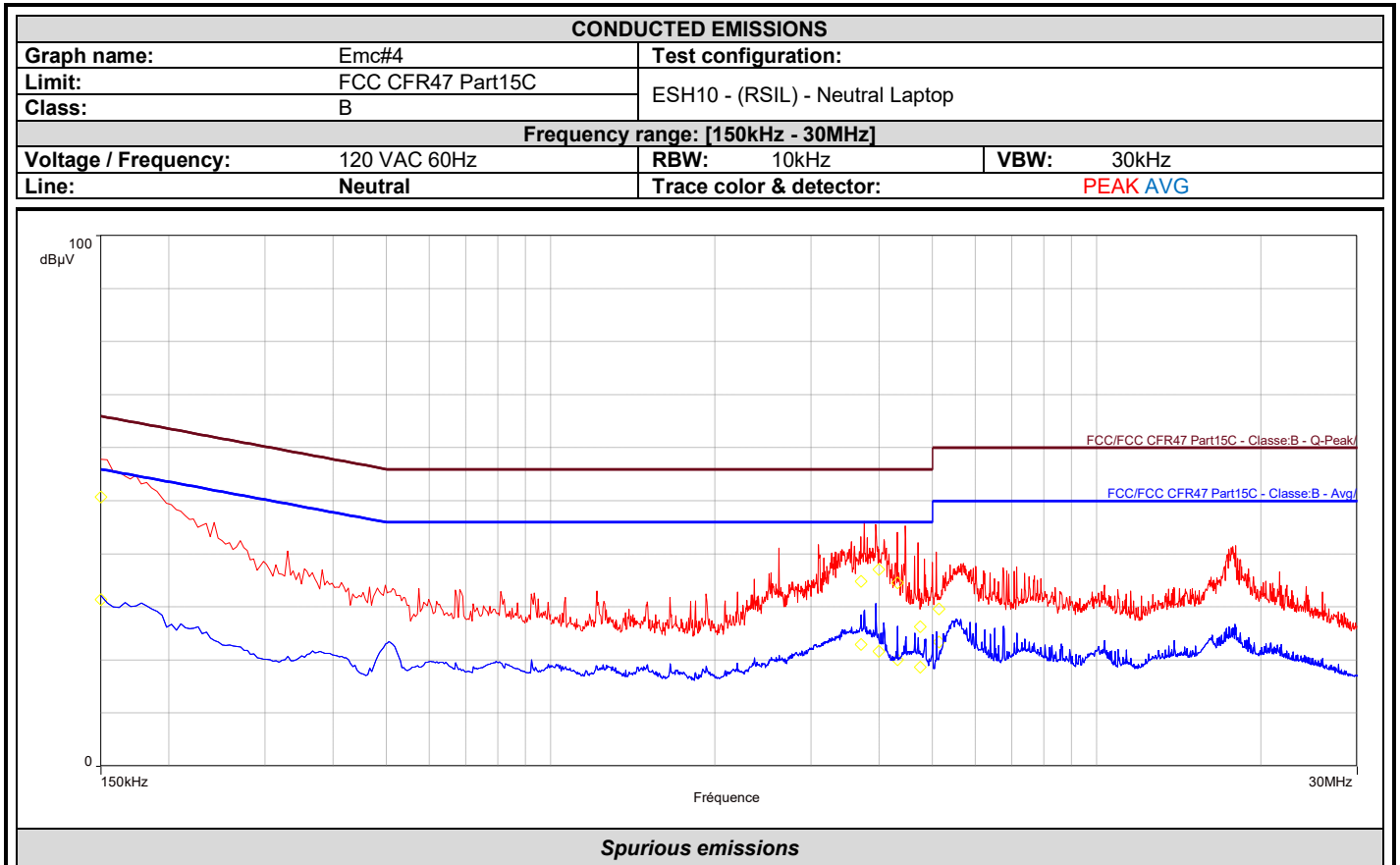

Frequency (MHz)	Q-Peak (dBµV)	Lim.Q-Peak (dBµV)	Q-Peak-Lim.Q-Peak (dB)	Avg (dBµV)	Lim.Avg (dBµV)	Avg-Lim.Avg (dB)	Correction (dB)
0.150	50.8	66.0	-15.2	31.5	56.0	-24.5	19.4
3.704	34.9	56.0	-21.1	23.0	46.0	-23.0	19.8
3.988	37.1	56.0	-18.9	21.6	46.0	-24.4	19.8
4.316	34.6	56.0	-21.4	20.1	46.0	-25.9	19.8
4.752	26.4	56.0	-29.6	18.7	46.0	-27.3	19.8
5.144	29.6	60.0	-30.4	23.4	50.0	-26.6	19.9



L C I E

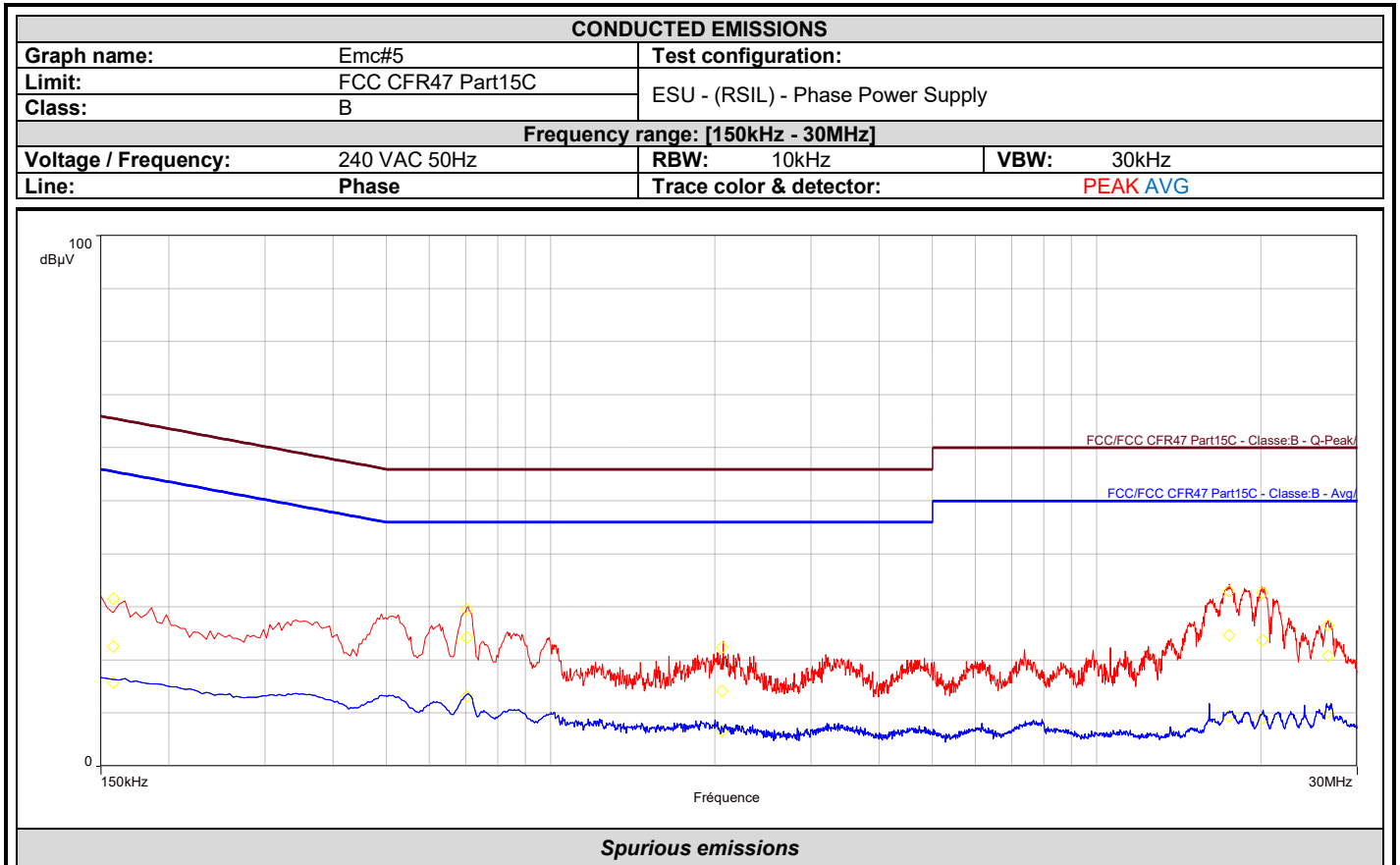

Frequency (MHz)	Peak (dBµV)	Q-Peak (dBµV)	Lim.Q-Peak (dBµV)	Q-Peak-Lim.Q-Peak (dB)	Avg (dBµV)	Lim.Avg (dBµV)	Avg-Lim.Avg (dB)	Correction (dB)
0.158	31.6	22.6	65.6	-43.0	15.8	55.6	-39.8	19.5
0.702	29.6	24.2	56.0	-31.8	13.2	46.0	-32.8	19.6
2.060	22.4	14.2	56.0	-41.8	6.7	46.0	-39.3	19.7
17.476	33.0	24.7	60.0	-35.3	9.5	50.0	-40.5	20.7
20.128	32.7	23.8	60.0	-36.2	9.1	50.0	-40.9	20.8
26.524	26.6	20.8	60.0	-39.2	10.2	50.0	-39.8	21.2



L C I E

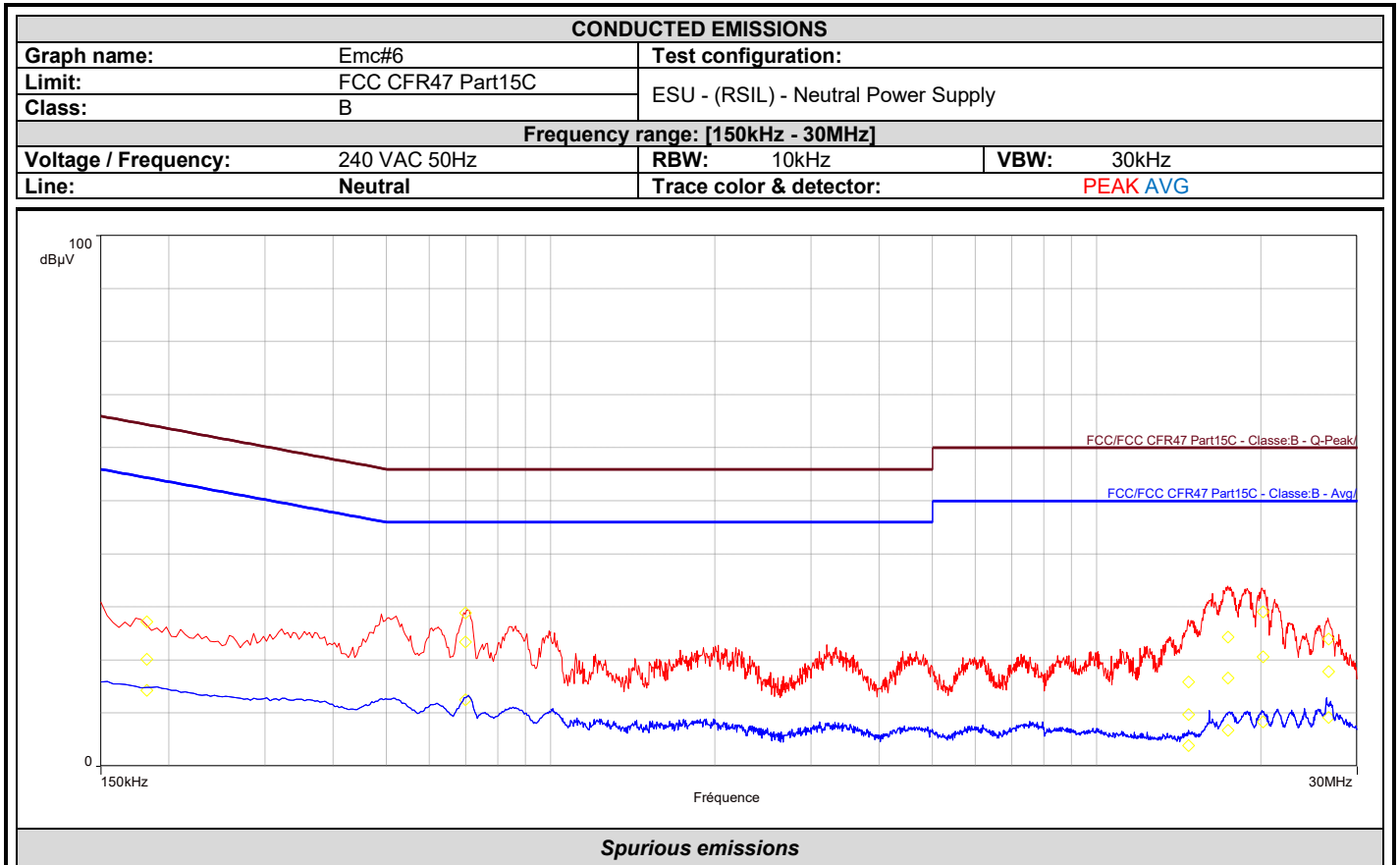

Frequency (MHz)	Peak (dBµV)	Q-Peak (dBµV)	Lim.Q-Peak (dBµV)	Q-Peak-Lim.Q-Peak (dB)	Avg (dBµV)	Lim.Avg (dBµV)	Avg-Lim.Avg (dB)	Correction (dB)
0.182	27.3	20.2	64.4	-44.2	14.3	54.4	-40.0	19.5
0.698	28.9	23.4	56.0	-32.6	12.5	46.0	-33.5	19.6
14.732	15.9	9.8	60.0	-50.2	3.9	50.0	-46.1	20.5
17.400	24.3	16.6	60.0	-43.4	6.8	50.0	-43.2	20.7
20.152	29.1	20.7	60.0	-39.3	8.4	50.0	-41.6	20.8
26.572	24.0	17.9	60.0	-42.1	9.2	50.0	-40.8	21.2



L C I E

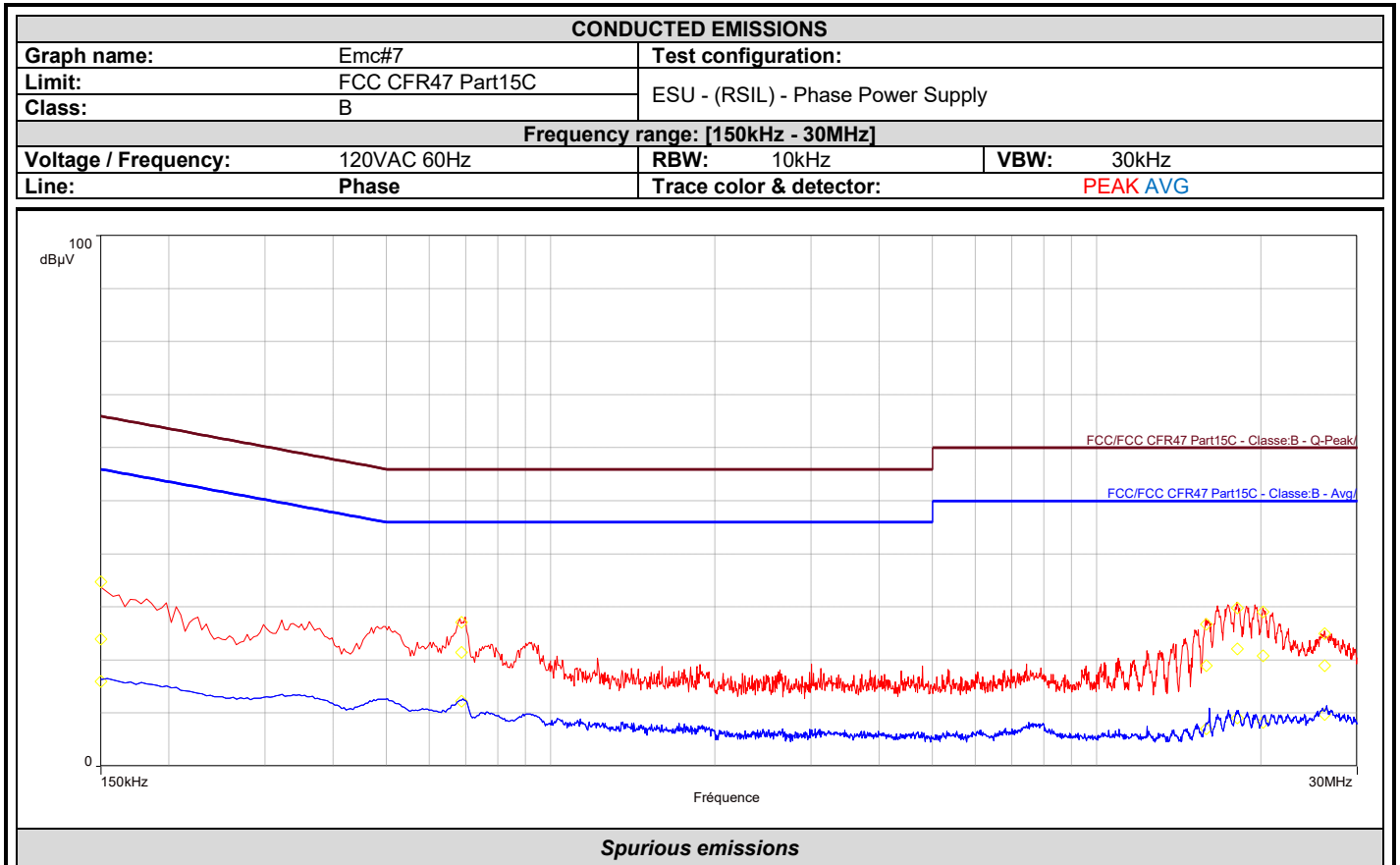

Frequency (MHz)	Peak (dBµV)	Q-Peak (dBµV)	Lim.Q-Peak (dBµV)	Q-Peak-Lim.Q-Peak (dB)	Avg (dBµV)	Lim.Avg (dBµV)	Avg-Lim.Avg (dB)	Correction (dB)
0.150	34.8	24.0	66.0	-42.0	16.0	56.0	-40.0	19.4
0.686	27.2	21.5	56.0	-34.5	12.2	46.0	-33.8	19.6
15.868	26.8	19.0	60.0	-41.0	7.1	50.0	-42.9	20.6
18.084	29.9	22.1	60.0	-37.9	9.1	50.0	-40.9	20.7
20.160	29.1	20.8	60.0	-39.2	8.3	50.0	-41.7	20.8
26.156	25.0	19.0	60.0	-41.0	9.8	50.0	-40.2	21.2



L C I E

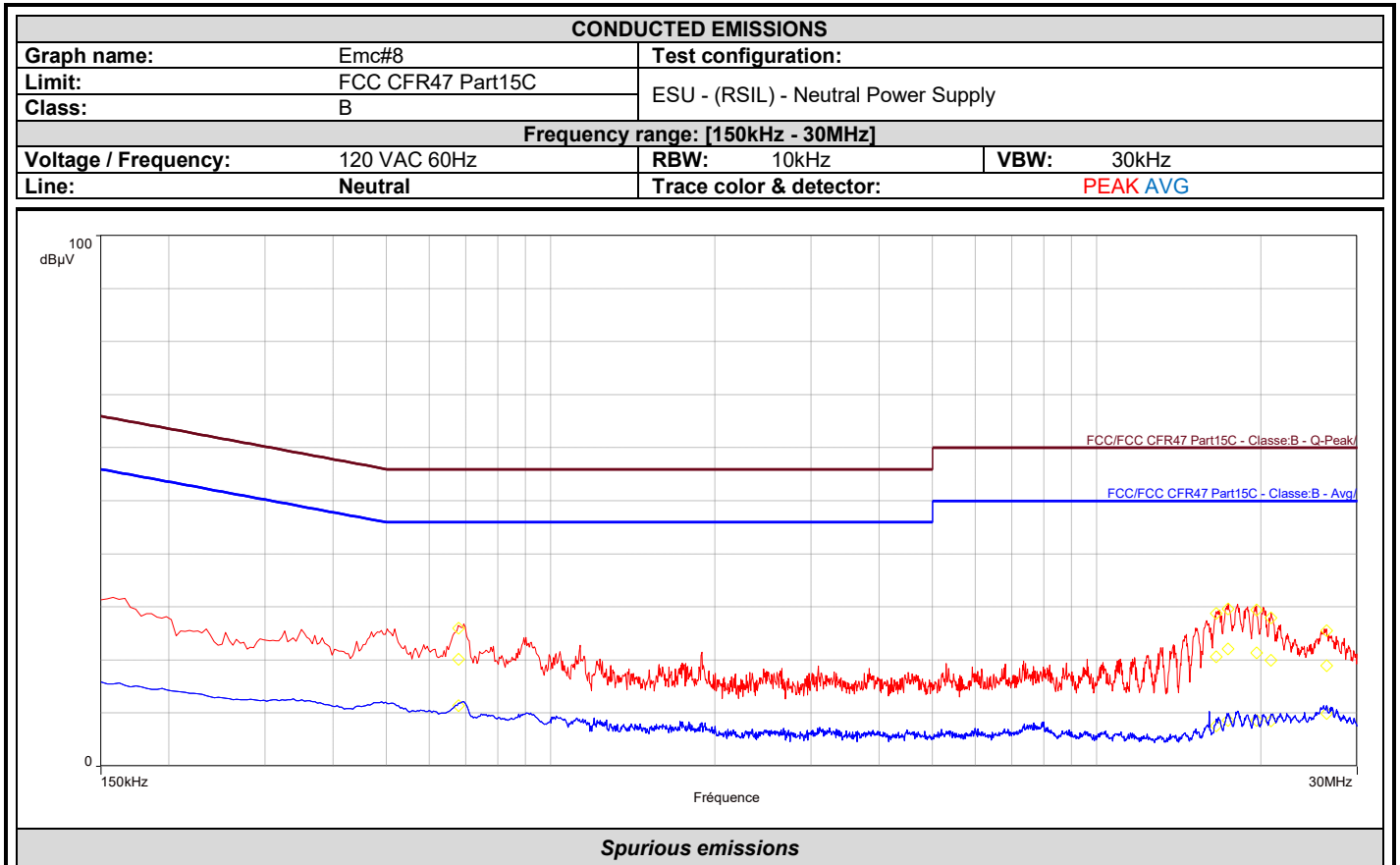

Frequency (MHz)	Peak (dBµV)	Q-Peak (dBµV)	Lim.Q-Peak (dBµV)	Q-Peak-Lim.Q-Peak (dB)	Avg (dBµV)	Lim.Avg (dBµV)	Avg-Lim.Avg (dB)	Correction (dB)
0.678	26.0	20.2	56.0	-35.8	11.5	46.0	-34.5	19.6
16.556	28.8	20.7	60.0	-39.3	7.6	50.0	-42.4	20.6
17.412	29.7	22.1	60.0	-37.9	8.6	50.0	-41.4	20.7
19.620	29.5	21.4	60.0	-38.6	8.7	50.0	-41.3	20.8
20.840	28.0	20.0	60.0	-40.0	8.6	50.0	-41.4	20.9
26.352	25.6	18.9	60.0	-41.1	10.0	50.0	-40.0	21.2

9.7. CONCLUSION

Ac Power Line Conducted Emission measurement performed on the sample of the product **STMICROELECTRONICS STM32WB5MMGH**, SN: **Sample RF** , in configuration and description presented in this test report, show levels **compliant** to the 47 CFR PART 15.247 & RSS 247 limits.

10. UNWANTED EMISSIONS IN RESTRICTED FREQUENCY BANDS

10.1. TEST CONDITIONS

Test performed by : Gaetan DESCHAMPS
 Date of test : April 12, 2022
 Ambient temperature : 22 °C
 Relative humidity : 35 %

10.2. TEST SETUP

The product has been tested according to ANSI C63.10 (2013) and FCC part15 subpart C.

Test is performed in parallel, perpendicular and ground parallel axis with a loop antenna below 30MHz. Measurement bandwidth was 200Hz below 150kHz and 9kHz between 150kHz & 30MHz. The level has been maximised by the turntable rotation of 360 degrees range on all axis of EUT used in normal configuration. Antenna height was 1m. The EUT is placed **on an open area test site**. Distance between measuring antenna and the EUT is **10m**.

Test is performed in horizontal (H) and vertical (V) polarization with **bilog** between 30MHz & 1GHz and with a horn antenna above 1GHz. Measurement bandwidth was 120kHz below 1GHz and 1MHz above 1GHz. The level has been maximised by the turntable rotation of 360 degrees range on all axis of EUT used in normal configuration. The EUT is placed at 1.5m high above 1GHz and at 0.8m high under 1GHz. The EUT is placed **in a full anechoic chamber** above 1GHz and **on an open area test site** from 30MHz to 1GHz. Distance between measuring antenna and the EUT is **3m**. The height antenna is varied from 1m to 4m from 30MHz to 1GHz and above 1GHz is:

On mast, varied from 1m to 4m

Fixed and centered on the EUT (EUT smaller than the beamwidth of the measurement antenna, ANSI C63.10 §6.6.5)

Frequency list has been created with anechoic chamber pre-scan results.

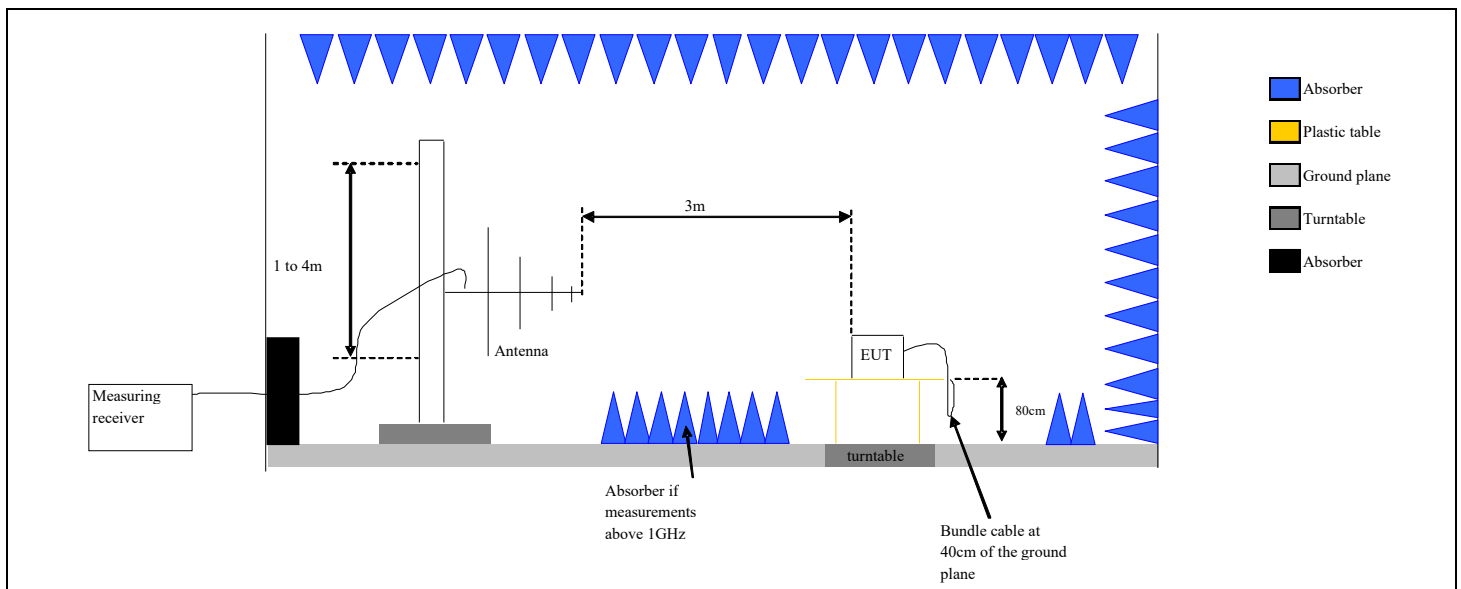

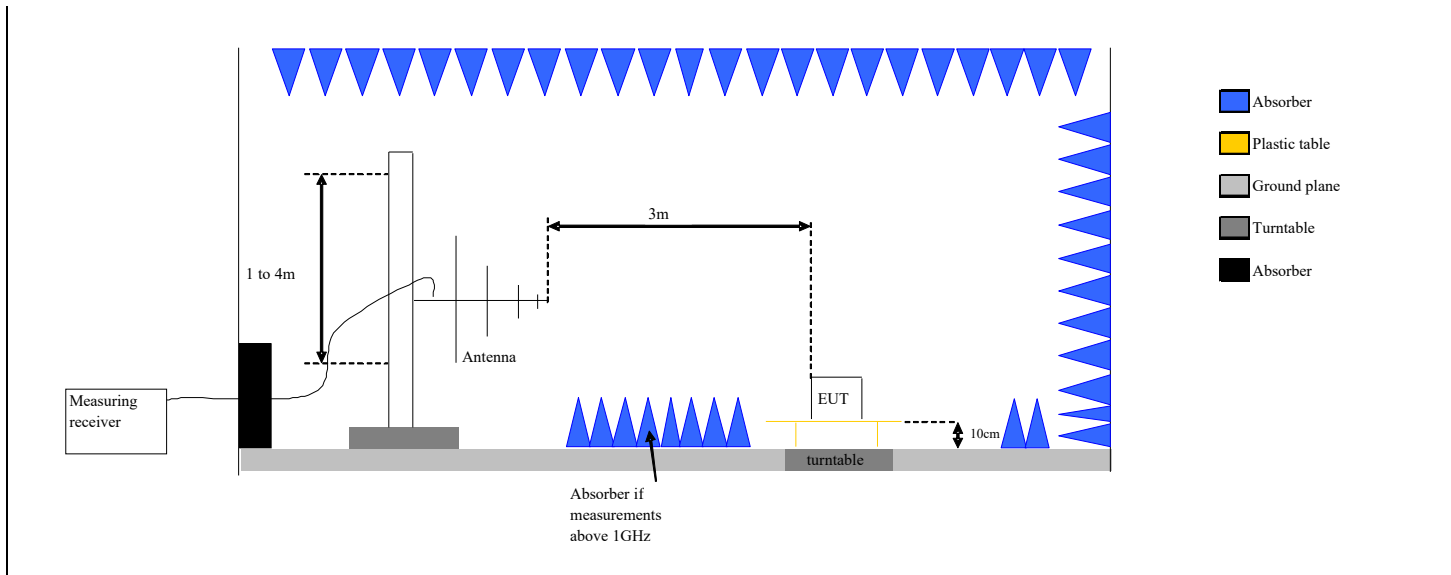

Test set up of Unwanted Emissions in Restricted Frequency Bands in semi anechoic chamber

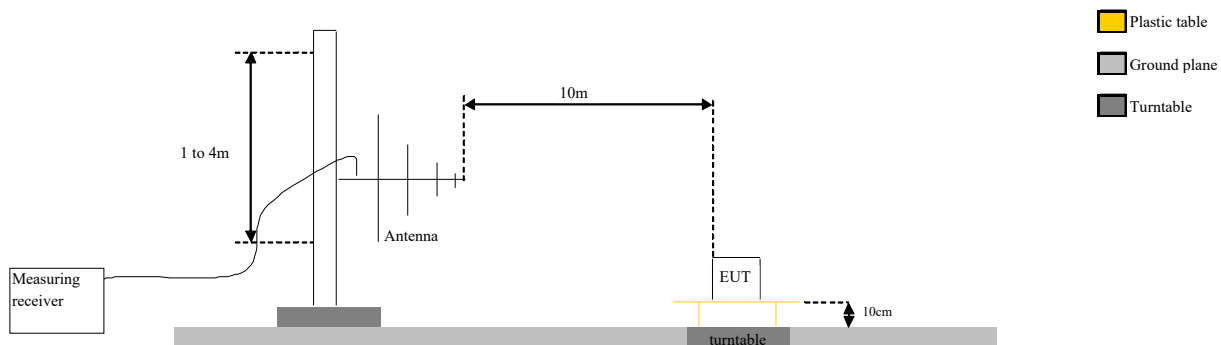
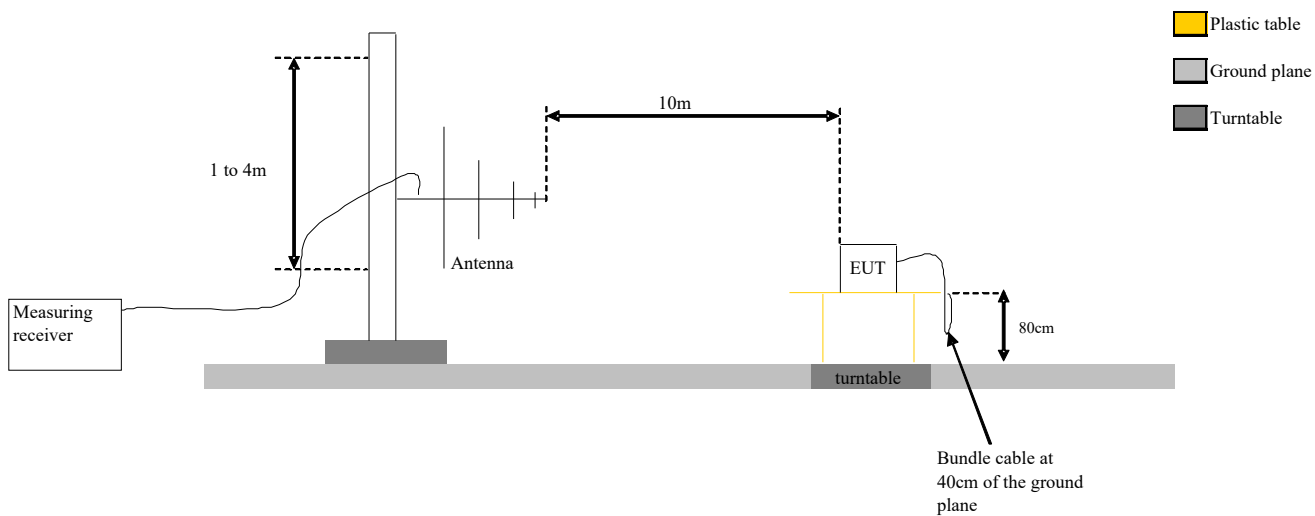

Test Set up for radiated measurement in open area test site

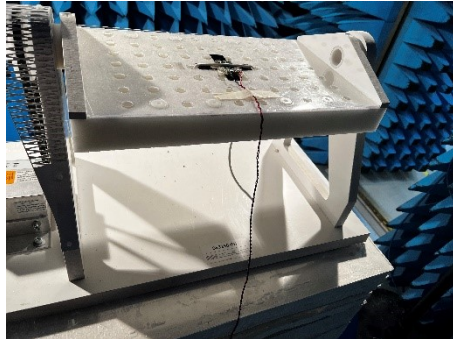

Test setup (example: angus 0°)

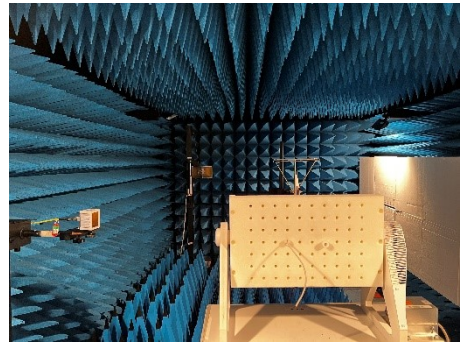
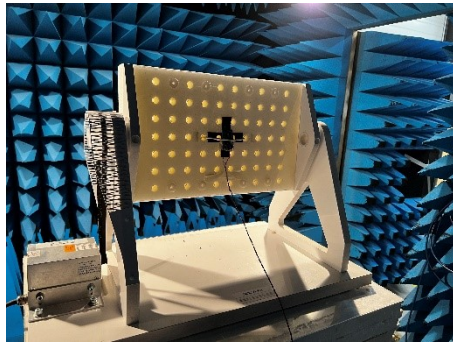

Test setup in Axis (example: angus 90°)



OATS Test setup



OATS Test setup (Biconic and Bi-Log antenna)



L C I E

10.3. LIMIT

Measure at 300m		
Frequency range	Level	Detector
9kHz-490kHz	67.6dB μ V/m /F(kHz)	QPeak
Measure at 30m		
Frequency range	Level	Detector
490kHz-1.705MHz	87.6dB μ V/m /F(kHz)	QPeak
1.705MHz-30MHz	29.5dB μ V/m	QPeak
Measure at 10m		
Frequency range	Level	Detector
30MHz to 88MHz	29.5dB μ V/m	QPeak
88MHz to 216MHz	33dB μ V/m	QPeak
216MHz to 960MHz	35.5B μ V/m	QPeak
960MHz to 1000MHz	43.5dB μ V/m	QPeak
Above 1000MHz	63.5dB μ V/m	Peak
	43.5dB μ V/m	Average
Measure at 3m		
Frequency range	Level	Detector
30MHz to 88MHz	40dB μ V/m	QPeak
88MHz to 216MHz	43.5dB μ V/m	QPeak
216MHz to 960MHz	46B μ V/m	QPeak
960MHz to 1000MHz	54dB μ V/m	QPeak
Above 1000MHz	74dB μ V/m	Peak
	54dB μ V/m	Average



LCIE

10.4. TEST EQUIPMENT LIST

TEST EQUIPMENT USED					
Description	Manufacturer	Model	Identifier	Cal_Date	Cal_Due
Amplifier 9kHz - 40GHz	LCIE SUD EST	-	A7102082	06/20	06/22
Antenna Bi-log	AH System	SAS-521-7	C2040180	02/21	02/23
Antenna Loop	EMCO	6502	C2040159	01/20	01/23
BAT EMC	NEXIO	v3.21.0.27	L1000115		
Cable SMA 40GHz 40cm	WITHWAVE	W101-SM1-0.4M	A5329979	04/21	08/22
Comb EMR HF	YORK	CGE01	A3169114		
CONTROLLER	INNCO	CO3000	D3044034		
Emission Cable <1GHz (Ampl <-> Cage)	INTELLICONNECT	C-KPKP-1503-500MM	A5329988	04/21	08/22
Filter Matrice	LCIE SUD EST	Combined filters	A7484078	09/20	09/22
Multimeter - CEM	FLUKE	189	A1240171	09/21	09/23
Power supply DC	METRIX	AX503	A7042308		
Rehausse Table C3	LCIE	-	F2000511		
Semi-Anechoic chamber #3 (BF)	SIEPEL	-	D3044017_BF	12/19	12/22
Semi-Anechoic chamber #3 (VSWR)	SIEPEL	-	D3044017_VSWR	12/19	12/22
Spare C3 Cable Measure	TELEDYNE	26GHz	A5329681	09/20	09/22
Spare C3 Cable Measure	TELEDYNE	26GHz	A5329680	09/20	09/22
Spectrum analyzer	ROHDE & SCHWARZ	FSU 26	A4060058	09/21	09/23
Table C3	LCIE	-	F2000461		
Thermo-hygrometer (PM1/2/3)	KIMO	HQ 210	B4206022	01/21	01/23
TILT	INNCO	TILT	D3044033		
Turntable chamber (Cage#3)	ETS Lingren	Model 2165	F2000371		
Turntable controller (Cage#3)	ETS Lingren	Model 2090	F2000444		
Antenna horn 18GHz	EMCO	3115	C2042029	03/22	03/25
Emission Cable (SMA 1m)	TELEDYNE	26GHz	A5329874	08/21	08/22
Emission Cable (SMA 3.3m)	TELEDYNE	26GHz	A5329875	08/21	08/22
Rehausse Table C3	LCIE	-	F2000507		
Thermo-hygrometer (C3)	OREGON	BAR206	B4204078	02/21	02/23
Antenna horn 40GHz	SCHWARZBECK	BBHA 9170	C2042028	09/18	01/22
Cable 1m 40GHz	INTELLICONNECT	C-KPKP-1503-1M	A5329987	04/21	08/22
SMA 1.5m	SUCOFLEX	18GHz	A5329864	04/21	08/22
Spare C3 Cable Measure	TELEDYNE	26GHz	A5329682	09/20	09/22
Spectrum analyzer	ROHDE & SCHWARZ	FSV 40	A4060059	11/21	11/23



LCIE

TEST EQUIPMENT USED					
Description	Manufacturer	Model	Identifier	Cal_Date	Cal_Due
Antenna Bi-log	CHASE	CBL6111A	C2040051	07/20	07/22
Antenna Mat (OATS)	ETS Lingren	2071-2	F2000392		
BAT EMC	NEXIO	v3.21.0.27	L1000115		
Cable (OATS)	–	1GHz	A5329623	08/21	08/22
Comb EMR HF	YORK	CGE01	A3169114		
Emission Cable	MICRO-COAX	1GHz	A5329656	08/21	08/22
Emission Cable	SUCOFLEX	6GHz	A5329061	08/21	08/22
Emission Cable	–	6GHz	A5329069	05/22	05/23
OATS	–	–	F2000409	04/21	08/22
Rehausse Table C1/OATS	LCIE	–	F2000512		
Table C1/OATS	LCIE	–	F2000445		
Thermo-hygrometer (PM1/2/3)	KIMO	HQ 210	B4206022	01/21	01/23
Turntable (OATS)	ETS Lingren	Model 2187	F2000403		
Turntable / Mast controller (OATS)	ETS Lingren	Model 2066	F2000372		
Biconic Antenna	EATON	94455-1	C2040234	03/21	03/23

Note: In our quality system, the test equipment calibration due is more & less 2 months

10.5. DIVERGENCE, ADDITION OR SUPPRESSION ON THE TEST SPECIFICATION

None Divergence:



L C I E

10.6. RESULTS

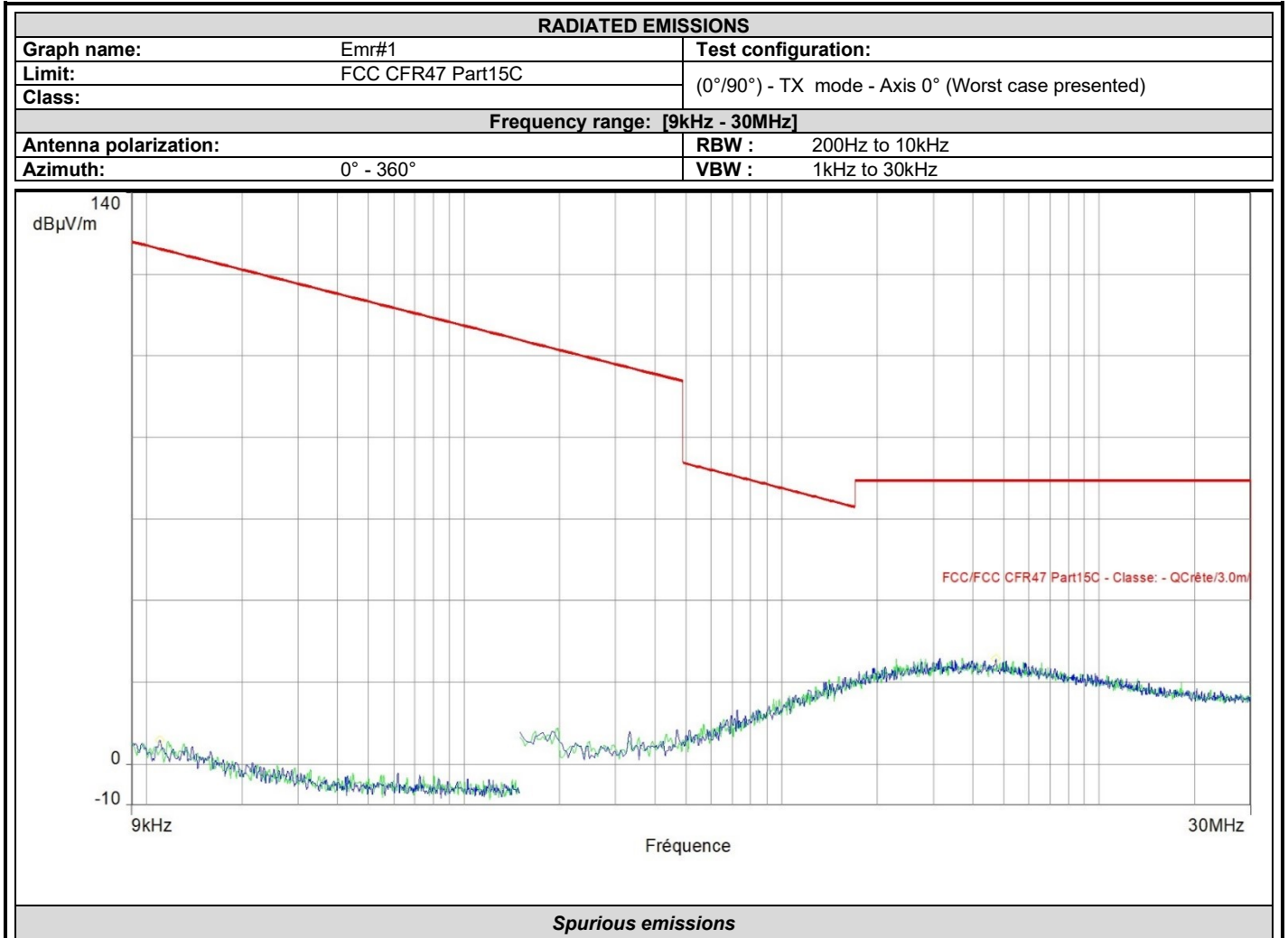

Frequency (MHz)	Peak (dBµV/m)	Lim.Q-Peak (dBµV/m)	Polarization	Correction (dB)
0.011	5.7	126.3	Horizontal	20.3
4.735	25.9	69.5	Horizontal	12.7



L C I E

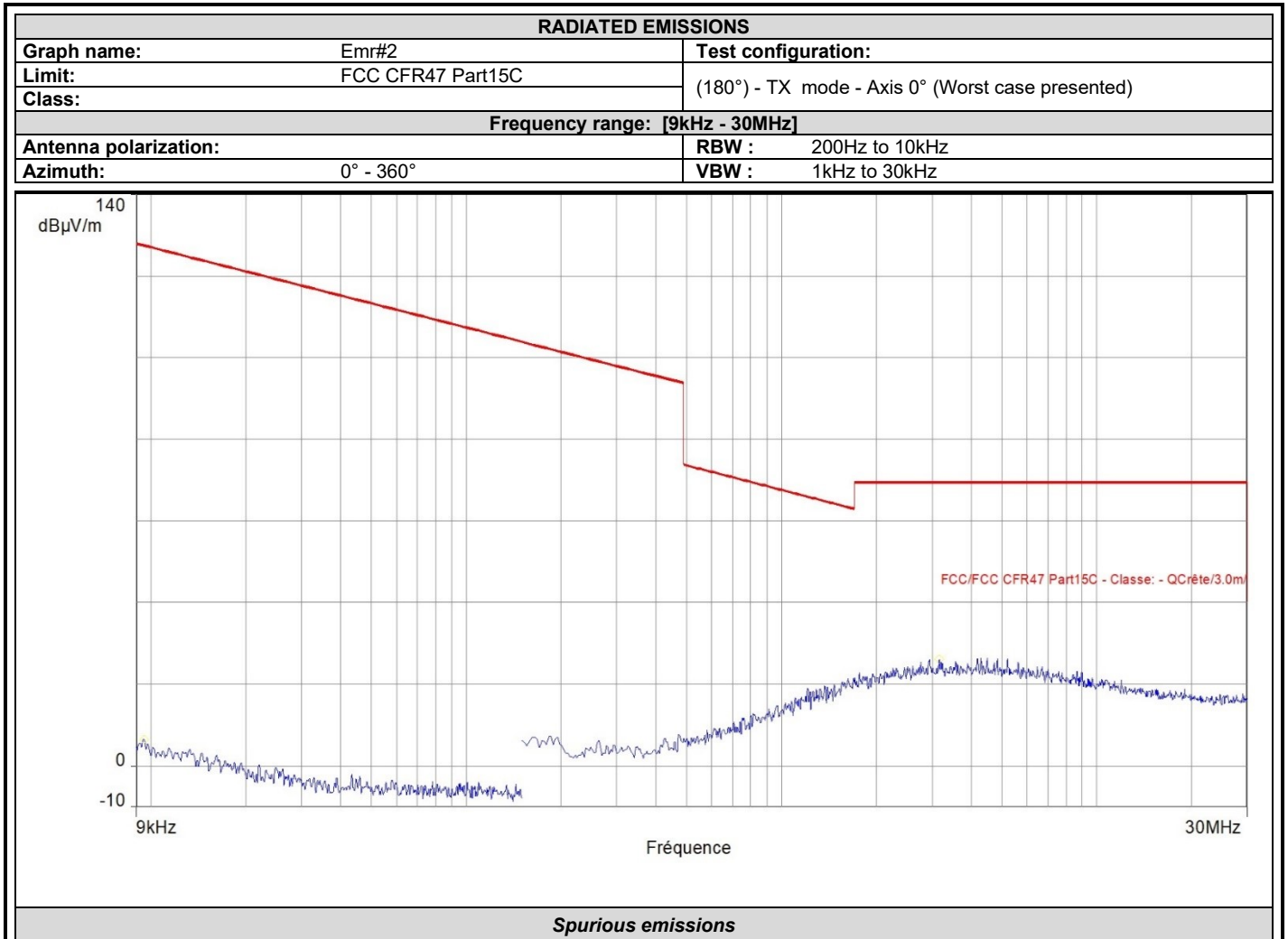

Frequency (MHz)	Peak (dBµV/m)	Lim.Q-Peak (dBµV/m)	Polarization	Correction (dB)
0.010	6.4	127.5	Horizontal	21.4
3.168	26.2	69.5	Horizontal	12.5



L C I E

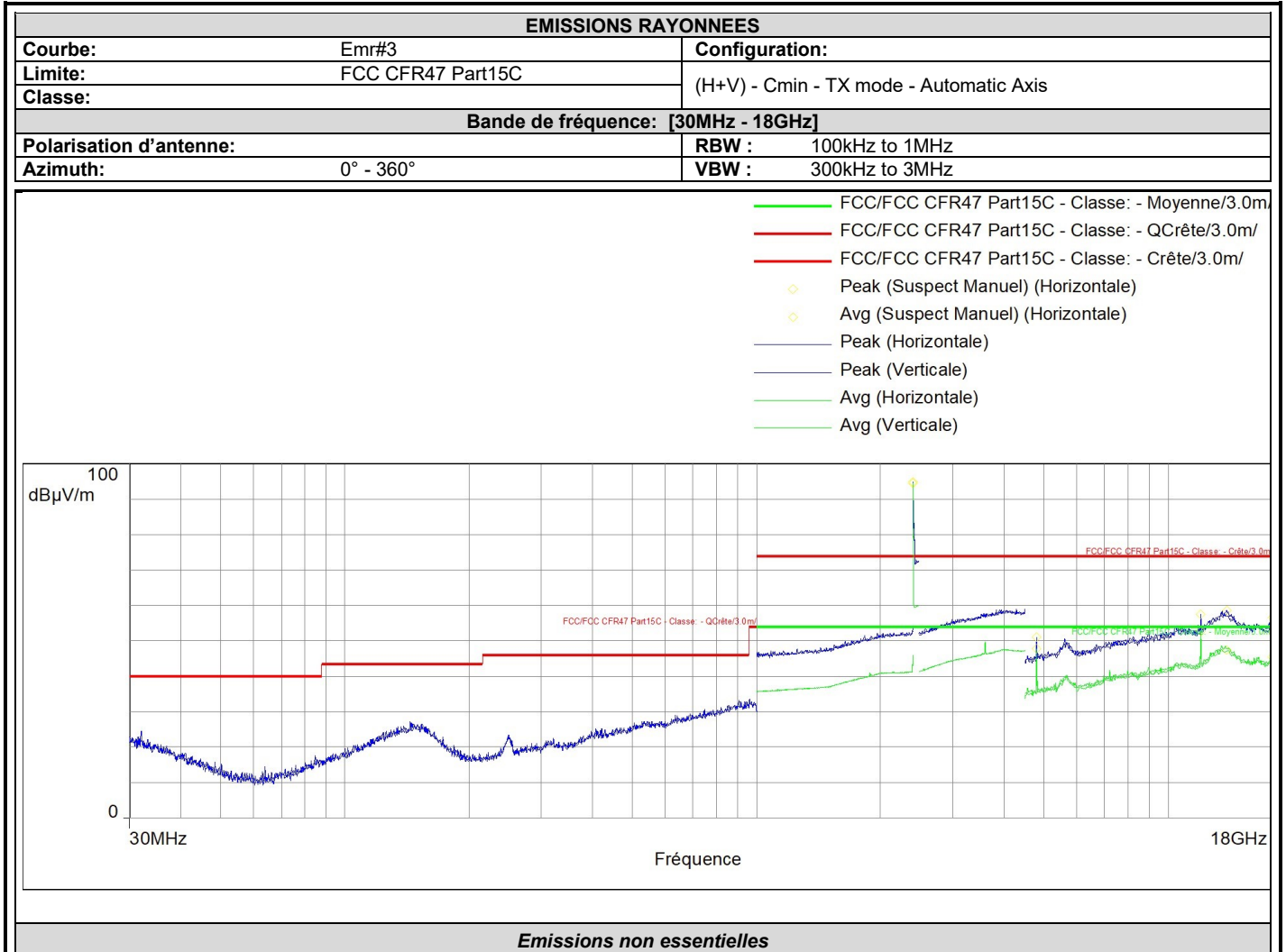

Frequency (MHz)	Peak (dBµV/m)	Lim.Peak (dBµV/m)	Avg (dBµV/m)	Lim.Avg (dBµV/m)	Lim.Q-Peak (dBµV/m)	Angle1 (°)	Polarisation	Correction (dB)
2401.962	94.9	74.0	94.6	54.0		83.0	Horizontal	34.8
4803.750	51.1	74.0	47.8	54.0		151.0	Horizontal	-21.9
12010.219	57.5	74.0	52.8	54.0		89.0	Horizontal	-13.6
13892.625	58.5	74.0	47.4	54.0		175.0	Horizontal	-8.7
17943.469	56.6	74.0	45.4	54.0		151.0	Horizontal	10.9



L C I E

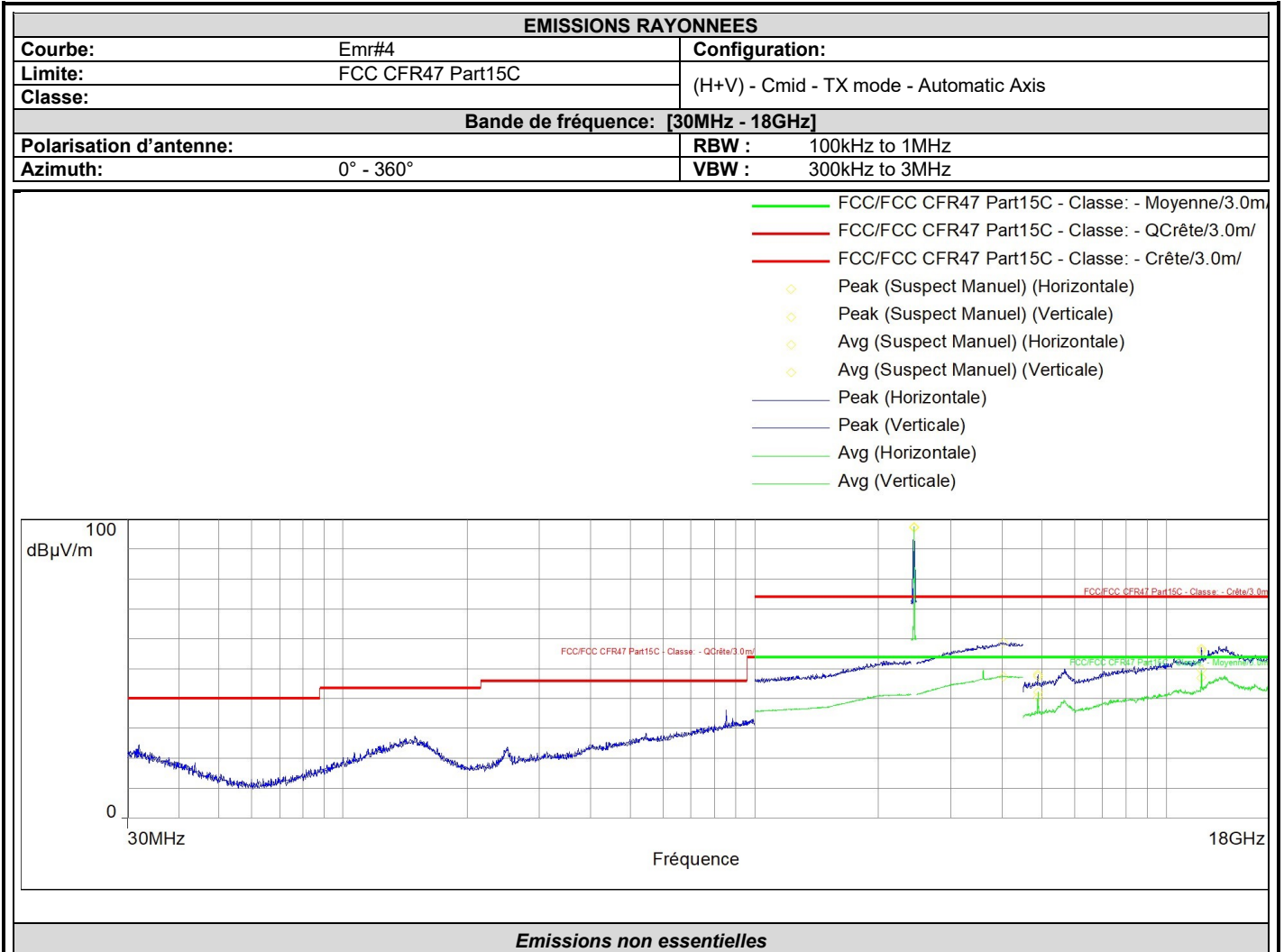

Frequency (MHz)	Peak (dBµV/m)	Lim.Peak (dBµV/m)	Avg (dBµV/m)	Lim.Avg (dBµV/m)	Lim.Q-Peak (dBµV/m)	Angle1 (°)	Polarisation	Correction (dB)
2441.959	97.5	74.0	97.2	54.0		72.0	Horizontal	34.8
4030.559	58.7	74.0	47.5	54.0		170.0	Horizontal	40.3
4883.906	48.0	74.0	42.1	54.0		135.0	Horizontal	-21.6
12209.344	56.2	74.0	49.5	54.0		0.0	Horizontal	-13.6
4883.906	47.3	74.0	40.6	54.0		64.0	Vertical	-21.6
12208.500	56.6	74.0	46.9	54.0		11.0	Vertical	-13.6



L C I E

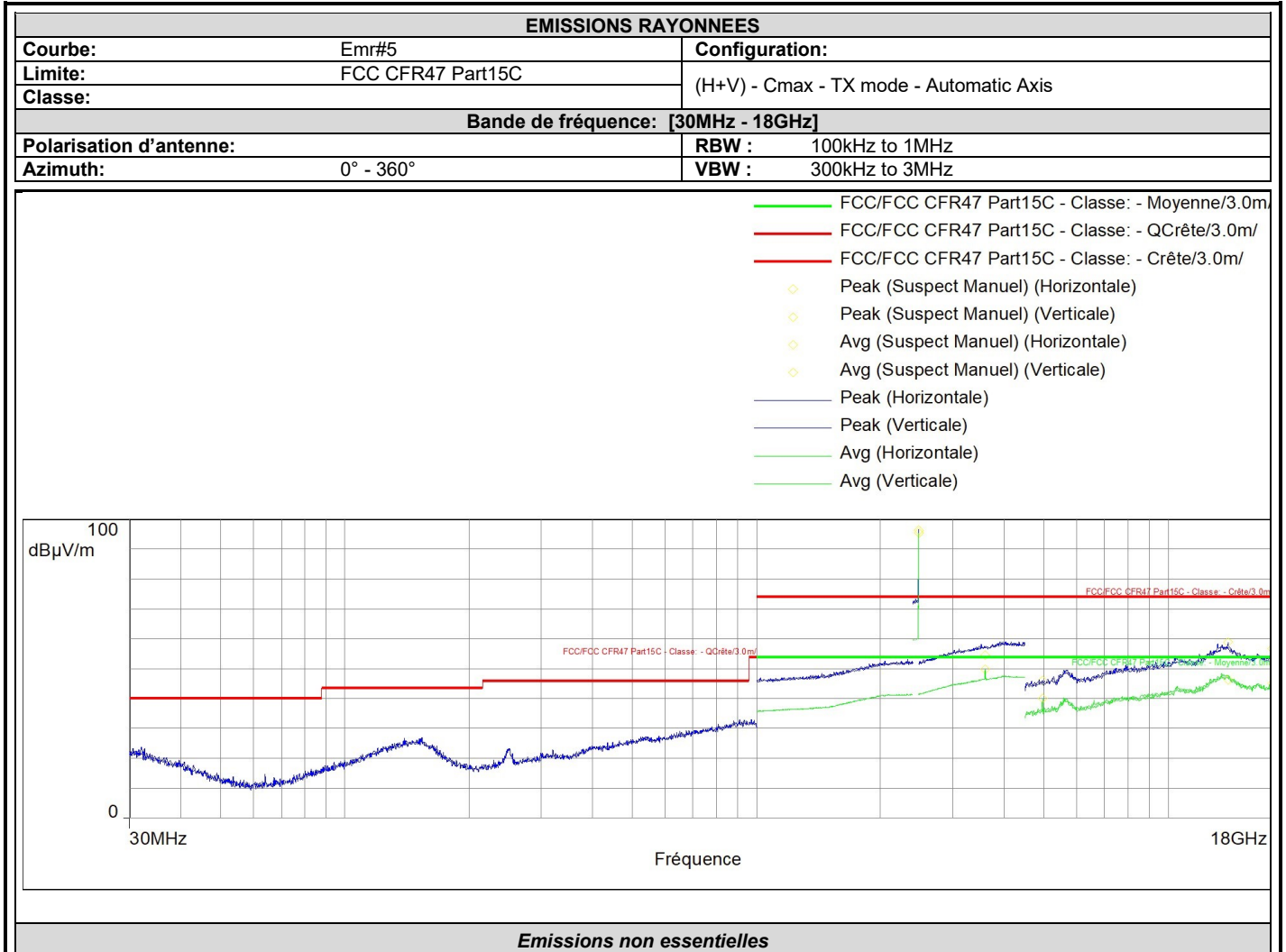

Frequency (MHz)	Peak (dBµV/m)	Lim.Peak (dBµV/m)	Avg (dBµV/m)	Lim.Avg (dBµV/m)	Lim.Q-Peak (dBµV/m)	Angle1 (°)	Polarisation	Correction (dB)
3599.834	54.6	74.0	49.8	54.0		317.0	Horizontal	39.1
4959.844	46.1	74.0	40.0	54.0		155.0	Horizontal	-21.6
14018.344	58.8	74.0	46.4	54.0		215.0	Horizontal	-8.1
17933.344	56.6	74.0	45.1	54.0		64.0	Horizontal	10.8
2479.993	96.4	74.0	95.4	54.0		344.0	Vertical	34.8



L C I E

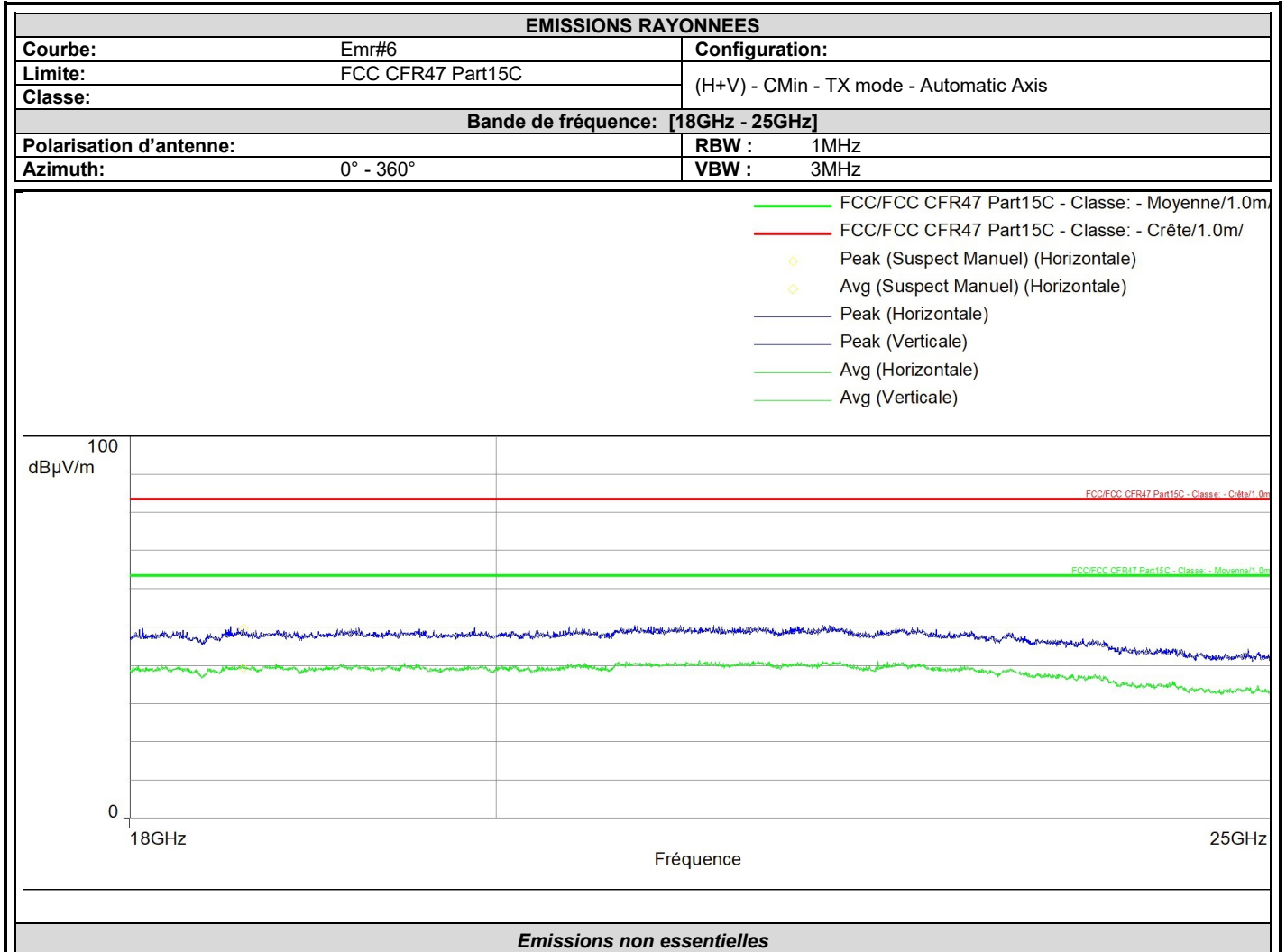

Frequency (MHz)	Peak (dBµV/m)	Lim.Peak (dBµV/m)	Avg (dBµV/m)	Lim.Avg (dBµV/m)	Angle1 (°)	Polarisation	Correction (dB)
18597.625	49.7	83.5	39.3	63.5	135.0	Horizontal	-4.2



L C I E

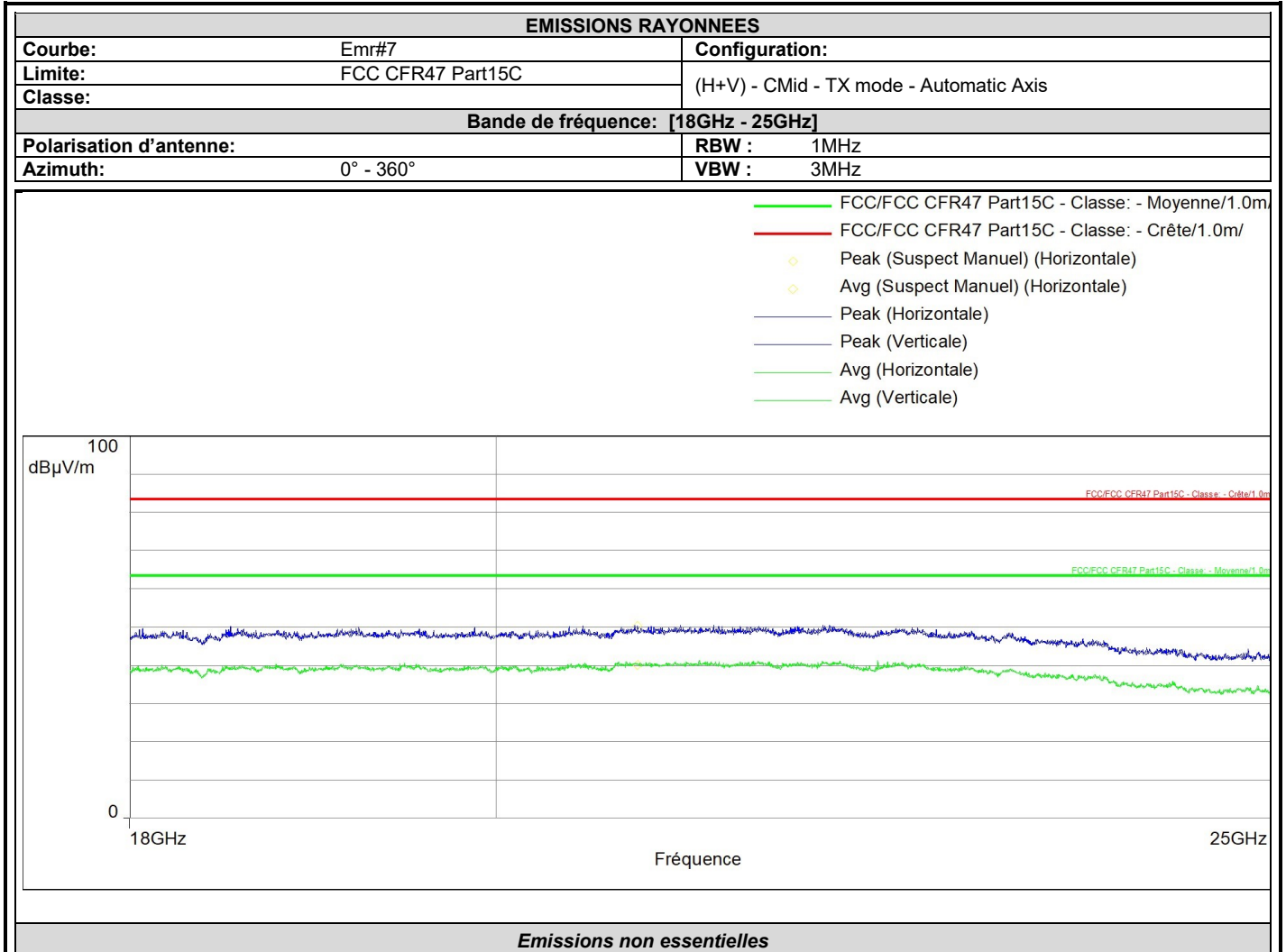

Frequency (MHz)	Peak (dBµV/m)	Lim.Peak (dBµV/m)	Avg (dBµV/m)	Lim.Avg (dBµV/m)	Angle1 (°)	Polarisation	Correction (dB)
20827.125	50.3	83.5	40.1	63.5	321.0	Horizontal	-4.0



L C I E

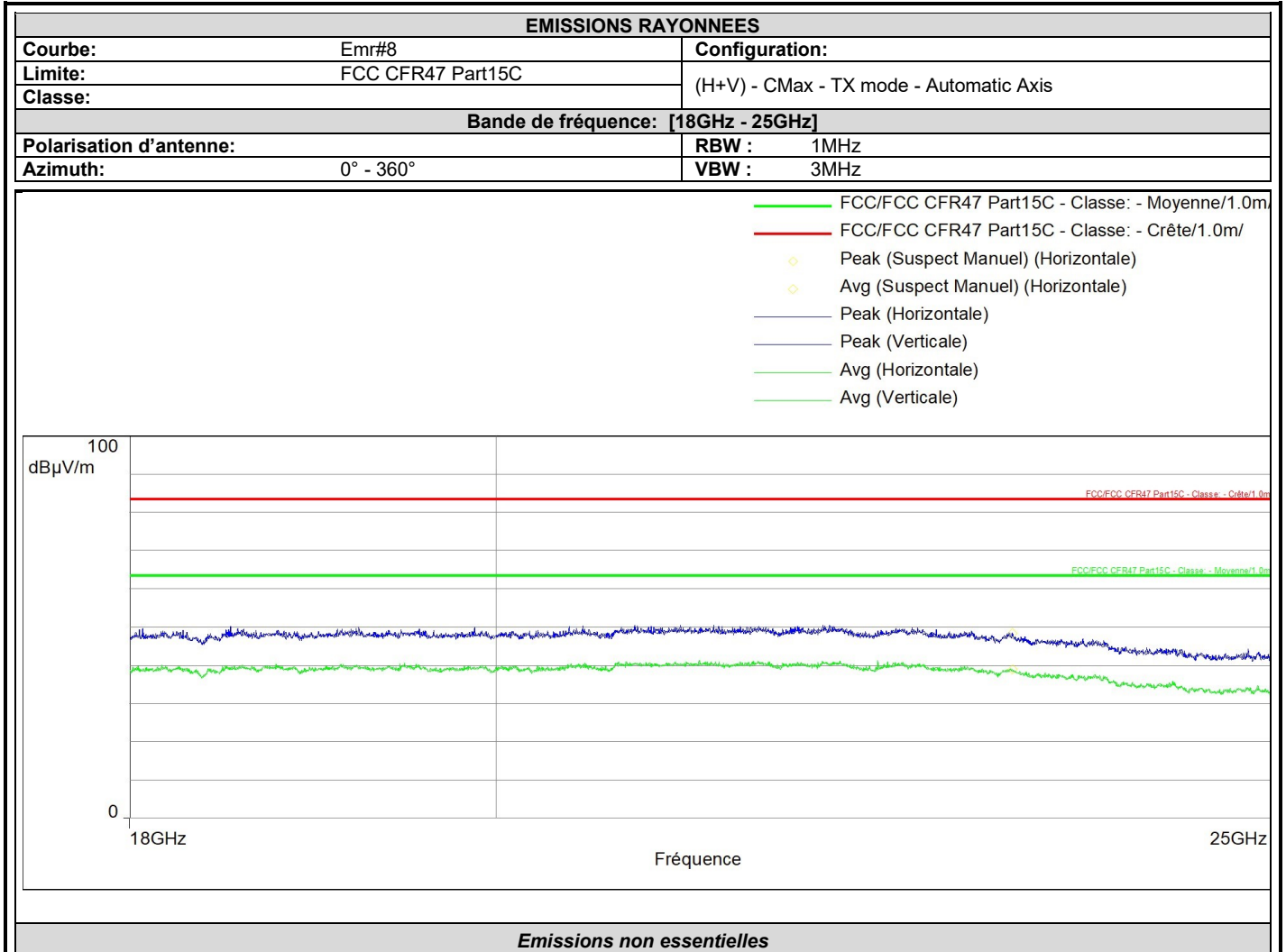

Frequency (MHz)	Peak (dBµV/m)	Lim.Peak (dBµV/m)	Avg (dBµV/m)	Lim.Avg (dBµV/m)	Angle1 (°)	Polarisation	Correction (dB)
23198.375	48.3	83.5	39.0	63.5	356.0	Horizontal	-2.8

QUALIFICATION (30MHz-1GHz): 10 meters measurement on the Open Area Test Site.
 Frequency list has been created with semi-anechoic chamber pre-scan results.
 Measurements are performed using a QUASI-PEAK detection.

Test Frequency (MHz)	Meter Reading dB(µV)	Detector (Pk/QP/Av)	Polarity (V/H)	Azimuth (Degrees)	Antenna Height (cm)	Transducer Factor (dB)	Level (dBµV/m)	Limit (dBµV/m)	Margin (dB)	Remark
No significant frequency observed										

Note: Measure have been done at 10m distance and corrected according to requirements of 15.209.e)
 (M@3m = M@10m+10.5dB)



Results in the frequency band [1-25] GHz: Worst case presented

QUALIFICATION (1GHz- 25GHz): The frequency list is created from the results obtained during the pre-characterization in anechoic chamber.

Measurements are performed using a PEAK and AVERAGE detection.

Test Frequency (MHz)	Meter Reading dB(μ V)	Detector (Pk/Av)	Polarity (V/H)	Azimuth (Degrees)	Antenna Height (cm)	Transducer Factor (dB)	Level (dB μ V/m)	Limit (dB μ V/m)	Margin (dB)	Remark
No significant frequency observed										

10.7. CONCLUSION

Unwanted Emission in restricted frequency bands measurement performed on the sample of the product **STMICROELECTRONICS STM32WB5MMGH**, SN: **Sample 9** in configuration and description presented in this test report, show levels **compliant** to the 47 CFR PART 15.247 & RSS 247 limits.

11. UNCERTAINTIES CHART

<i>Type de mesure / Kind of measurement</i>	Incertitude élargie laboratoire / Wide uncertainty laboratory (k=2) ± x	Incertitude limite du CISPR / CISPR uncertainty limit ± y
<i>Measurement of conducted disturbances in voltage on the power port</i>	3.29dB	3.4 dB
<i>Measurement of conducted disturbances in voltage on the telecommunication port.</i>	3.26 dB	5dB
<i>Measurement of discontinuous conducted disturbances in voltage</i>	3.33 dB	3.4 dB
<i>Measurement of conducted disturbances in current</i>	2.67 dB	2.9dB
<i>Spurious emission, radiated (Semi anechoic chamber & open test site)</i>	5.60 dB	6 dB
<i>Spurious emission, radiated (Full anechoic chamber above 1GHz)</i>	±3.8 dB	±6 dB
<i>Occupied Channel Bandwidth</i>	±2.8 %	±5 %
<i>RF power, conducted</i>	±1.2 dB	±1.5 dB
<i>Power Spectral Density, Conducted</i>	±1.7 dB	±3 dB
<i>Spurious emission, conducted</i>	±2.3 dB	±3 dB
<i>Temperature</i>	±0.75 °C	±3 °C
<i>Supply Voltages</i>	±1.7 %	±3 %

Les valeurs d'incertitudes calculées du laboratoire étant inférieures aux valeurs d'incertitudes limites établies par la norme, la conformité de l'échantillon est établie directement par les niveaux limites applicables. / *The uncertainty values calculated by the laboratory are lower than limit uncertainty values defined by the standard. The conformity of the sample is directly established by the applicable limits values.*