



Report No.: RZA2010-1332RF15C-R1



Part 15C

TEST REPORT

Product Name	GSM 850/1900 BT1.2 FM
FCC ID	YCNSL10
Model Name	A310
Marketing Name	SL10
Client	Lenovo Mobile Communication Technology Ltd.

TA Technology (Shanghai) Co., Ltd.



GENERAL SUMMARY

Product Name	GSM 850/1900 BT1.2 FM		
Model Name	A310	Marketing Name	SL10
FCC ID	YCNSL10	Report No.	RZA2010-1332RF15C-R1
Client	Lenovo Mobile Communication Technology Ltd.		
Manufacturer	Lenovo Mobile Communication Technology Ltd		
Reference Standard(s)	<p>FCC CFR47 Part 15C (2009-12) Radio Frequency Devices</p> <p>15.205 Restricted bands of operation;</p> <p>15.207 Conducted limits;</p> <p>15.209 Radiated emission limits; general requirements;</p> <p>15.247 Operation within the bands 902-928 MHz,2400-2483.5 MHz, and 5725-5850MHz.</p> <p>ANSI C63.4 Methods of Measurement of Radio-Noise Emission from Low-Voltage Electrical and Electronic Equipment in the Range of 9 KHz to 40GHz. (2003)</p> <p>DA00-705 Filing and Frequency Measurement Guidelines For Frequency Hopping Spread Spectrum System.(2000)</p>		
Conclusion	<p>This portable wireless equipment has been measured in all cases requested by the relevant standards. Test results in Chapter 2 of this test report are below limits specified in the relevant standards.</p> <p>General Judgment: Pass</p> <p>(Stamp)</p> <p>Date of issue: September 15th, 2010</p> 		
Comment	The test result only responds to the measured sample.		

Approved

by



Yang Weizhong

Revised by

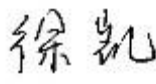

Xu Kai

Performed by



Du Ruwei

TABLE OF CONTENT

1. General Information	4
1.1. Notes of the test report.....	4
1.2. Testing laboratory	4
1.3. Applicant Information	5
1.4. Manufacturer Information.....	5
1.5. Information of EUT	6
1.6. Test Date	7
2. Test Information.....	8
2.1. Summary of test results	8
2.2. Peak Power Output –Conducted.....	9
2.3. Occupied Bandwidth (20dB)	12
2.4. Frequency Separation.....	15
2.5. Time of Occupancy (Dwell Time)	18
2.6. Band Edge Compliance	21
2.7. Spurious Radiated Emissions in the Restricted Band	24
2.8. Number of hopping Frequency.....	28
2.9. Spurious RF Conducted Emissions.....	31
2.10. Radiates Emission.....	38
2.11. Conducted Emission.....	52
3. Main Test Instruments	59
ANNEX A: EUT Appearance and Test Setup.....	60
A.1 EUT Appearance.....	60
A.2 Test Setup.....	62

1. General Information

1.1. Notes of the test report

TA Technology (Shanghai) Co., Ltd. guarantees the reliability of the data presented in this test report, which is the results of measurements and tests performed for the items under test on the date and under the conditions stated in this test report and is based on the knowledge and technical facilities available at TA Technology (Shanghai) Co., Ltd. at the time of execution of the test.

TA Technology (Shanghai) Co., Ltd. is liable to the client for the maintenance by its personnel of the confidentiality of all information related to the items under test and the results of the test. This report only refers to the item that has undergone the test.

This report standalone dose not constitute or imply by its own an approval of the product by the certification Bodies or competent Authorities. This report cannot be used partially or in full for publicity and/or promotional purposes without previous written approval of **TA Technology (Shanghai) Co., Ltd.** and the Accreditation Bodies, if it applies.

1.2. Testing laboratory

Company: TA Technology (Shanghai) Co., Ltd.
Address: No.145, Jintang Rd, Tangzhen Industry Park, Pudong
City: Shanghai
Post code: 201201
Country: P. R. China
Contact: Yang Weizhong
Telephone: +86-021-50791141/2/3
Fax: +86-021-50791141/2/3-8000
Website: <http://www.ta-shanghai.com>
E-mail: yangweizhong@ta-shanghai.com

TA Technology (Shanghai) Co., Ltd.
Test Report

Registration Num:428261

Report No.: RZA2010-1332RF15C-R1

Page 5 of 62

1.3. Applicant Information

Company: Lenovo Mobile Communication Technology Ltd.
Address: No.999,Qishan North 2nd Road,Information&Optoelectronics Park,Torch
Hi-tech Indu
City: Xiamen
Postal Code: /
Country: P.R.China
Contact: Qiu shouyu
Telephone: 86-0592-2166651
Fax: 86-0592-2169999-6651

1.4. Manufacturer Information

Company: Lenovo Mobile Communication Technology Ltd.
Address: No.999,Qishan North 2nd Road,Information&Optoelectronics Park,Torch
Hi-tech Indu
City: Xiamen
Postal Code: /
Country: P.R.China
Telephone: 86-0592-2166651
Fax: 86-0592-2169999-6651

1.5. Information of EUT

General information

Name of EUT:	GSM 850/1900 BT1.2 FM
IMEI:	862328004588317
Device Operating Configurations:	
Mode	Basic Rate
Modulation	GFSK
Packet Type:(Maximum Payload)	DH5
Max Conducted Power	-1.851dBm
Power Supply:	Battery or Adapter
Rated Power Supply Voltage:	3.8V
Extreme Voltage:	Minimum: 3.4V Maximum: 4.2V
Extreme Temperature:	Lowest: -15°C Highest: +55°C
Operating Frequency Range(s)	2400 ~ 2483.5 MHz
Hardware Version:	HUAQIN23_08A_HW
Software Version:	LANIX_SL10_MX_S008_100818
Antenna Type:	Internal Antenna

TA Technology (Shanghai) Co., Ltd.
Test Report

Registration Num:428261

Report No.: RZA2010-1332RF15C-R1

Page 7 of 62

Auxiliary equipment details

AE1: Battery

Model: BL110
Manufacturer: LiShen
S/N: 201004-1102083050

AE2: Adapter

Model: cp-13
Manufacturer: KunXing
S/N: /

Equipment Under Test (EUT) is GSM 850/1900 BT1.2 FM with internal antenna. The EUT supports Bluetooth.

The sample under test was selected by the Client.

Components list please refer to documents of the manufacturer.

1.6. Test Date

The test is performed from September 1, 2010 to September 14, 2010.

2. Test Information

2.1. Summary of test results

Number	Summary of measurements of results	Clause in FCC rules	Verdict
1	Peak Power Output -Conducted	15.247(b)(1)	PASS
2	Occupied Bandwidth (20dB)	15.247(a)(1)	PASS
3	Frequency Separation	15.247(a)(1)	PASS
4	Time of Occupancy (Dwell Time)	15.247(a)(1)(iii)	PASS
5	Band Edge Compliance	15.247(d)	PASS
6	Spurious Radiated Emissions in the restricted band	15.247(d),15.205,15.209	PASS
7	Number of Hopping Frequency	15.247(a)(1)(iii)	PASS
8	Spurious RF Conducted Emissions	15.247(d)	PASS
9	Radiates Emission	15.247(d),15.205,15.209	PASS
10	AC Power Line Conducted Emission	15.207	PASS

TA Technology (Shanghai) Co., Ltd.
Test Report

Registration Num:428261

Report No.: RZA2010-1332RF15C-R1

Page 9 of 62

2.2. Peak Power Output –Conducted

Ambient condition

Temperature	Relative humidity	Pressure
23°C ~25°C	45%~50%	101.5kPa

Methods of Measurement

During the process of the testing, The EUT was connected to the spectrum analyzer and Bluetooth test set via a power splitter with a known loss. The EUT is controlled by the Bluetooth test set to ensure max power transmission with proper modulation. The peak detector is used. RBW is set to 1MHz, VBW is set to 3MHz. These measurements have been tested at following channels: 0, 39, and 78.

Test Setup

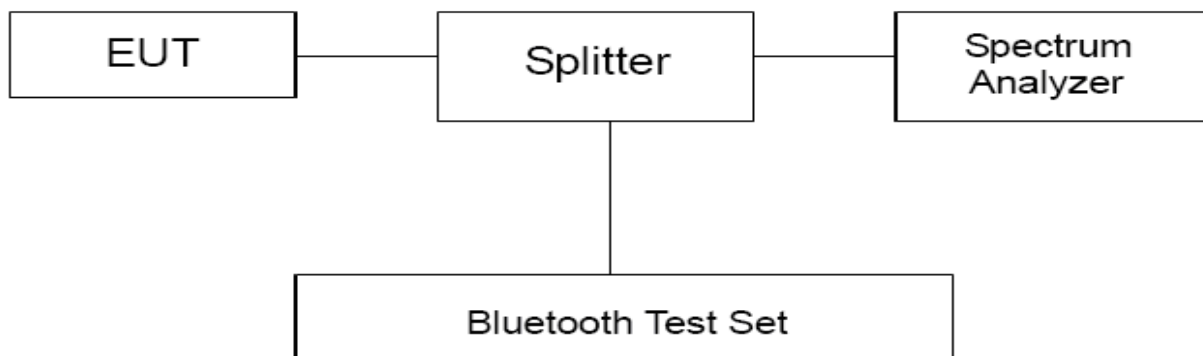

Limits

Rule Part 15.247 (b) (1) specifies that " For frequency hopping systems operating in the 2400–2483.5 MHz band employing at least 75 non-overlapping hopping channels, and all frequency hopping systems in the 5725–5850 MHz band: 1 watt. For all other frequency hopping systems in the 2400–2483.5 MHz band: 0.125 watts."

Peak Output Power	≤ 1W (30dBm)
-------------------	--------------

Measurement Uncertainty

The assessed measurement uncertainty to ensure 95% confidence level for the normal distribution is with the coverage factor $k = 2$. $U = 0.44$ dB.

TA Technology (Shanghai) Co., Ltd.

Test Report

Registration Num:428261

Report No.: RZA2010-1332RF15C-R1

Page 10 of 62

Test Results

Channel	Frequency (MHz)	Peak Output Power (dBm)	Conclusion
0	2402	-2.678	PASS
39	2441	-1.851	PASS
78	2480	-2.175	PASS

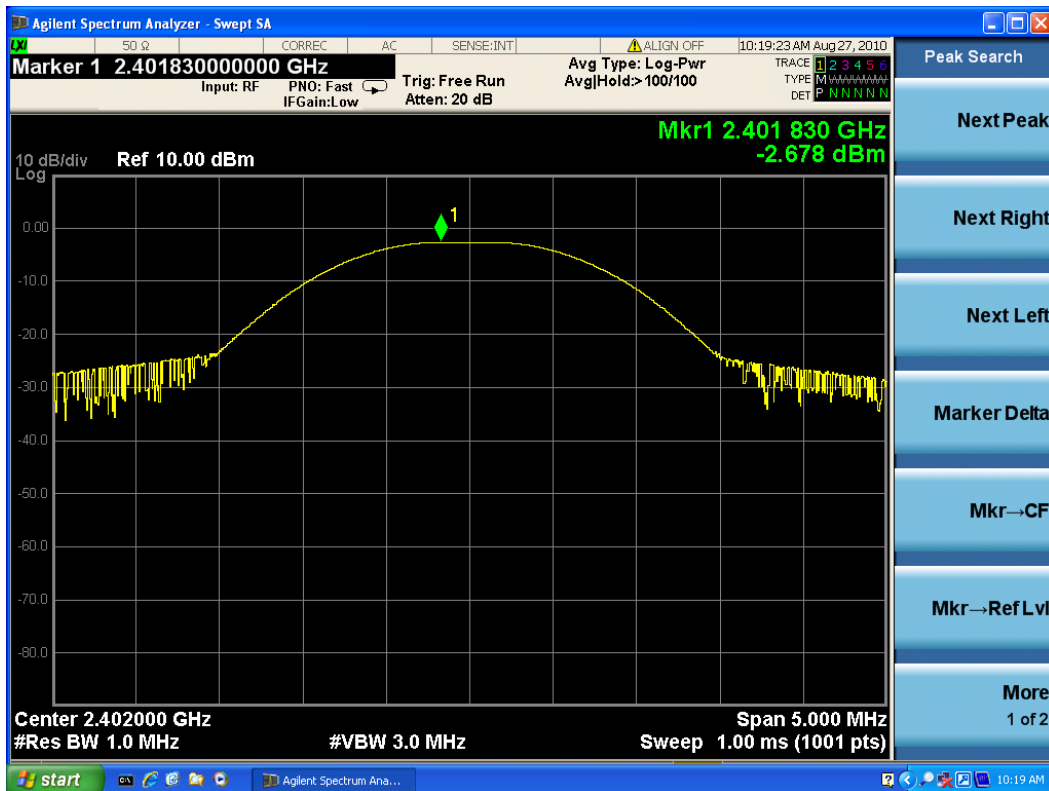

Carrier frequency (MHz): 2402

Channel No.:0

TA Technology (Shanghai) Co., Ltd.

Test Report

Registration Num:428261

Report No.: RZA2010-1332RF15C-R1

Page 11 of 62



Carrier frequency (MHz): 2441

Channel No.:39

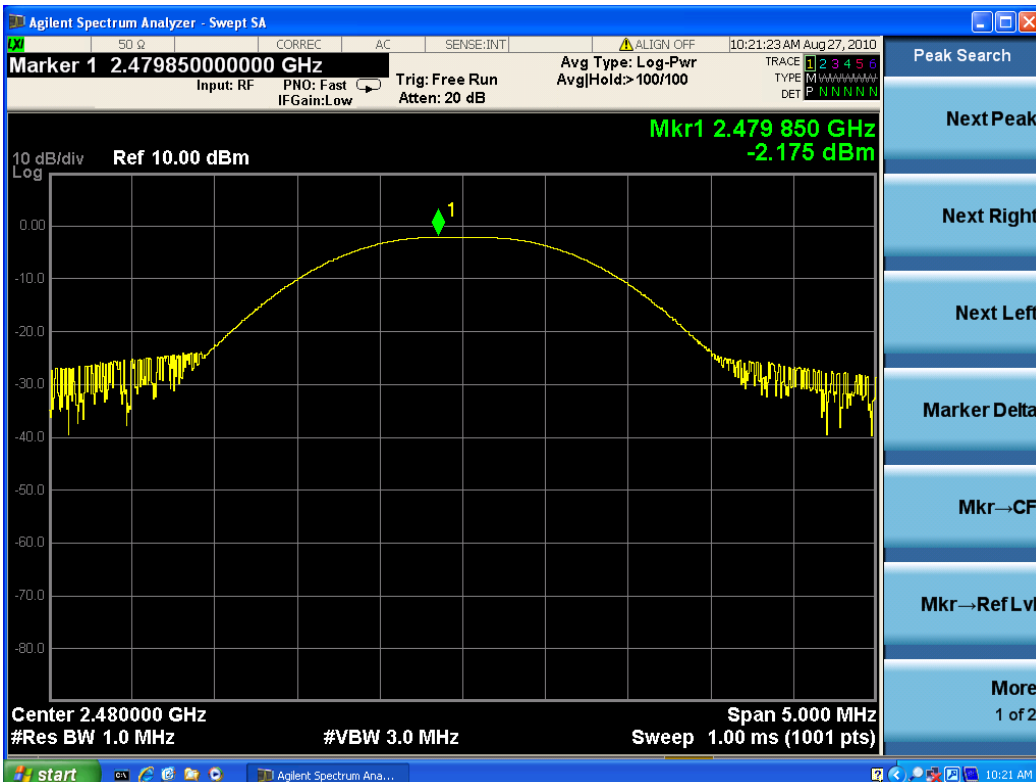

Carrier frequency (MHz): 2480

Channel No.:78

2.3. Occupied Bandwidth (20dB)

Ambient condition

Temperature	Relative humidity	Pressure
23°C ~25°C	45%~50%	101.5kPa

Method of Measurement

The EUT was connected to the spectrum analyzer and Bluetooth test set via a power splitter with a known loss. The occupied bandwidth is measured using spectrum analyzer. RBW is set to 10kHz and VBW is set to 30kHz on spectrum analyzer. -20dB occupied bandwidths are recorded.

Test Setup

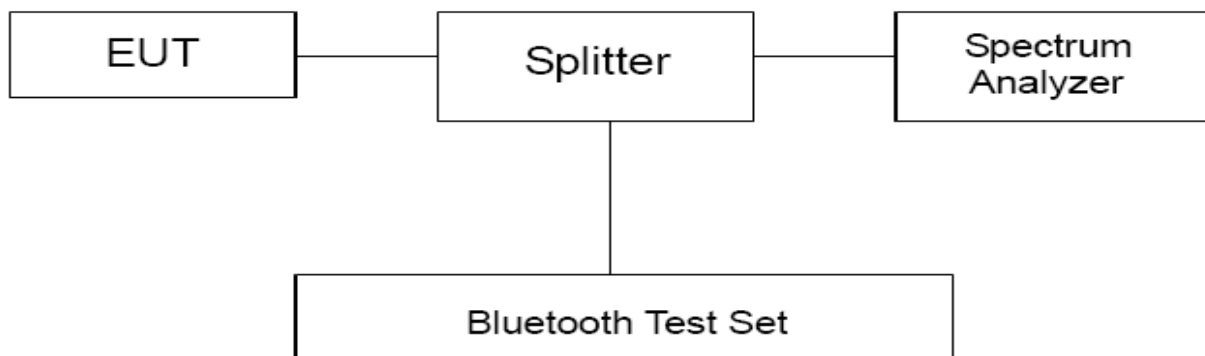

Limits

No specific occupied bandwidth requirements in part 15.247(a) (1).

Measurement Uncertainty

The assessed measurement uncertainty to ensure 95% confidence level for the normal distribution is with the coverage factor $k = 2$. $U = 936$ Hz.

Test Results

Channel	Frequency (MHz)	20dB Bandwidth (kHz)
0	2402	870.48
39	2441	869.92
78	2480	868.24

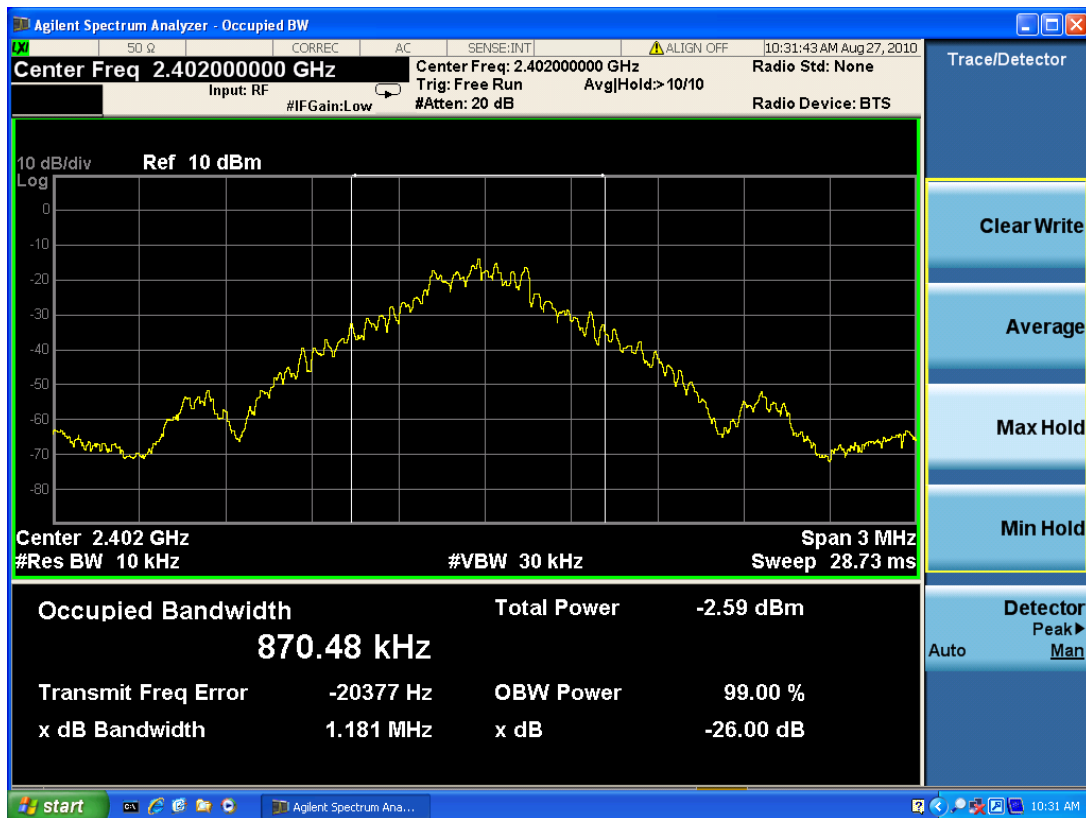

Carrier frequency (MHz): 2402
Channel No.:0

TA Technology (Shanghai) Co., Ltd. Test Report

Registration Num:428261

Report No.: RZA2010-1332RF15C-R1

Page 14 of 62

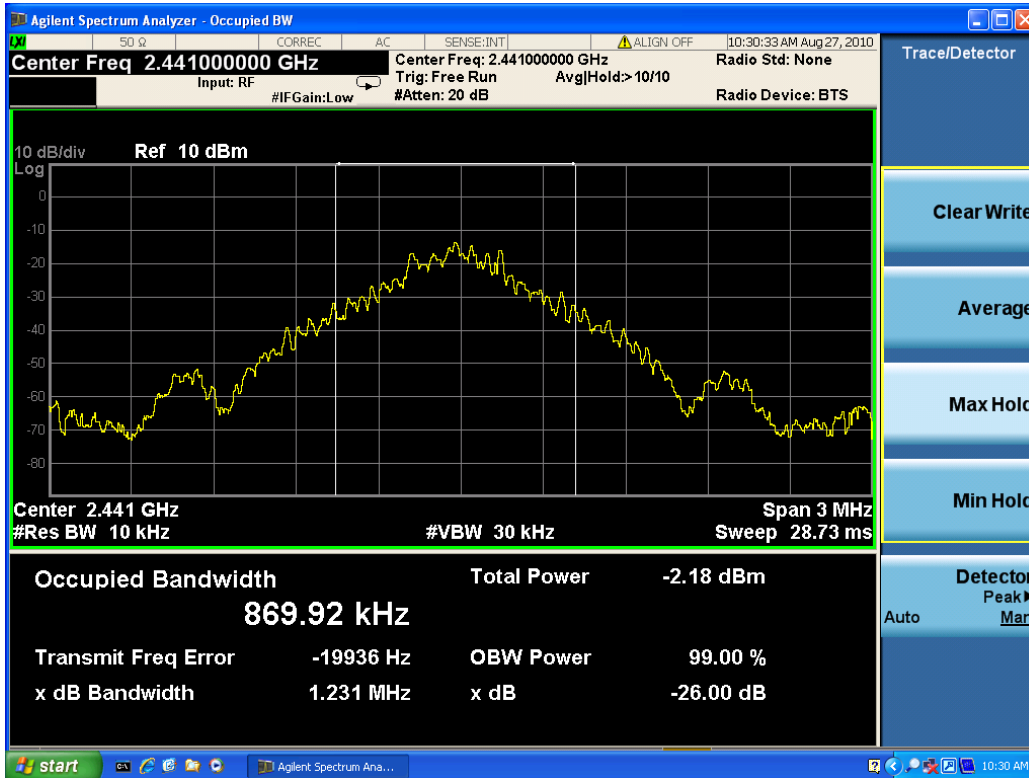

Carrier frequency (MHz): 2441
Channel No.:39

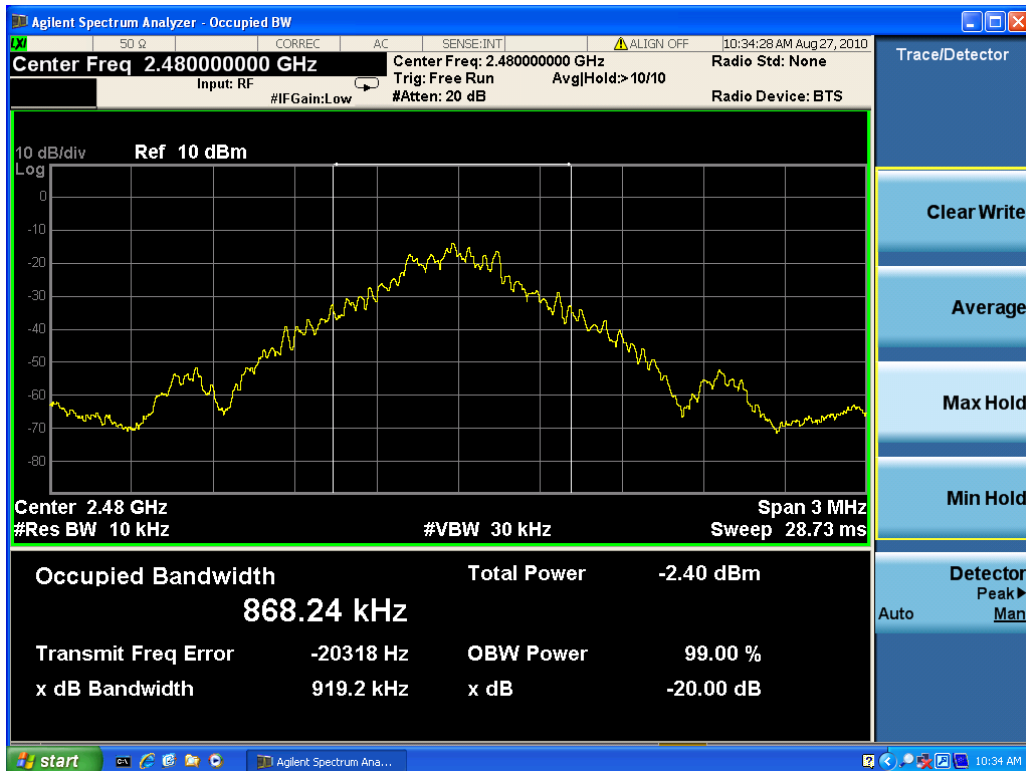

Carrier frequency (MHz): 2480
Channel No.:78

2.4. Frequency Separation

Ambient condition

Temperature	Relative humidity	Pressure
23°C ~25°C	45%~50%	101.5kPa

Method of Measurement

The Equipment Under Test (EUT) was set up in a shielded room to perform the spurious emissions measurements. The EUT was connected to the spectrum analyzer and Bluetooth test set via a power splitter with a known loss. RBW is set to 300kHz and VBW is set to 3MHz on spectrum analyzer. Set EUT on Hopping on mode.

Test setup

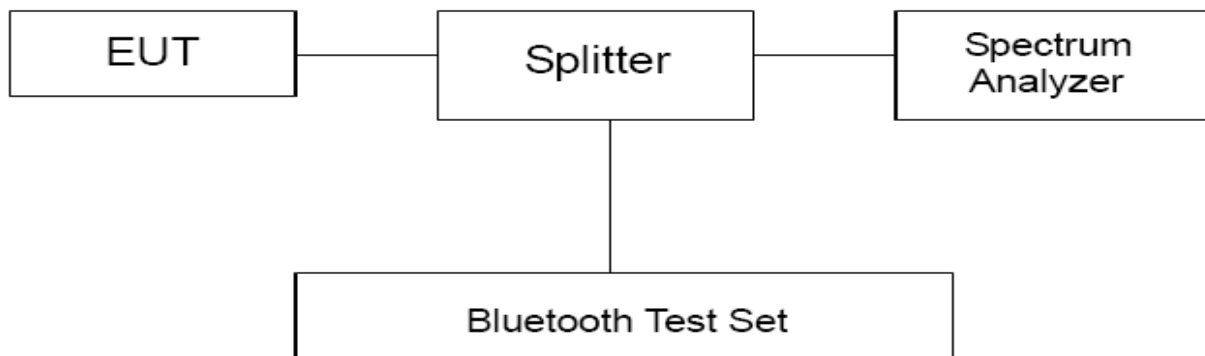

Limits

Rule Part 15.247(a)(1) specifies that “Frequency hopping systems shall have hopping channel carrier frequencies separated by a minimum of 25 kHz or the 20 dB bandwidth of the hopping channel, whichever is greater. Alternatively, frequency hopping systems operating in the 2400–2483.5 MHz band may have hopping channel carrier frequencies that are separated by 25 kHz or two-thirds of the 20 dB bandwidth of the hopping channel, whichever is greater, provided the systems operate with an output power no greater than 125 mW. ”

Note: The value of two-thirds of 20 dB bandwidth is always greater than 25 kHz.

Measurement Uncertainty

The assessed measurement uncertainty to ensure 95% confidence level for the normal distribution is with the coverage factor $k = 2$. $U = 936$ Hz.

TA Technology (Shanghai) Co., Ltd.

Test Report

Registration Num:428261

Report No.: RZA2010-1332RF15C-R1

Page 16 of 62

Test Results:

Carrier frequency (MHz)	Carrier frequency separation(kHz)	Limit(kHz)	Conclusion
2402	1002	580.32	PASS
2441	1002	579.95	PASS
2480	1002	578.83	PASS



Carrier frequency (MHz): 2402

Channel No.:0

TA Technology (Shanghai) Co., Ltd. Test Report

Registration Num:428261

Report No.: RZA2010-1332RF15C-R1

Page 17 of 62

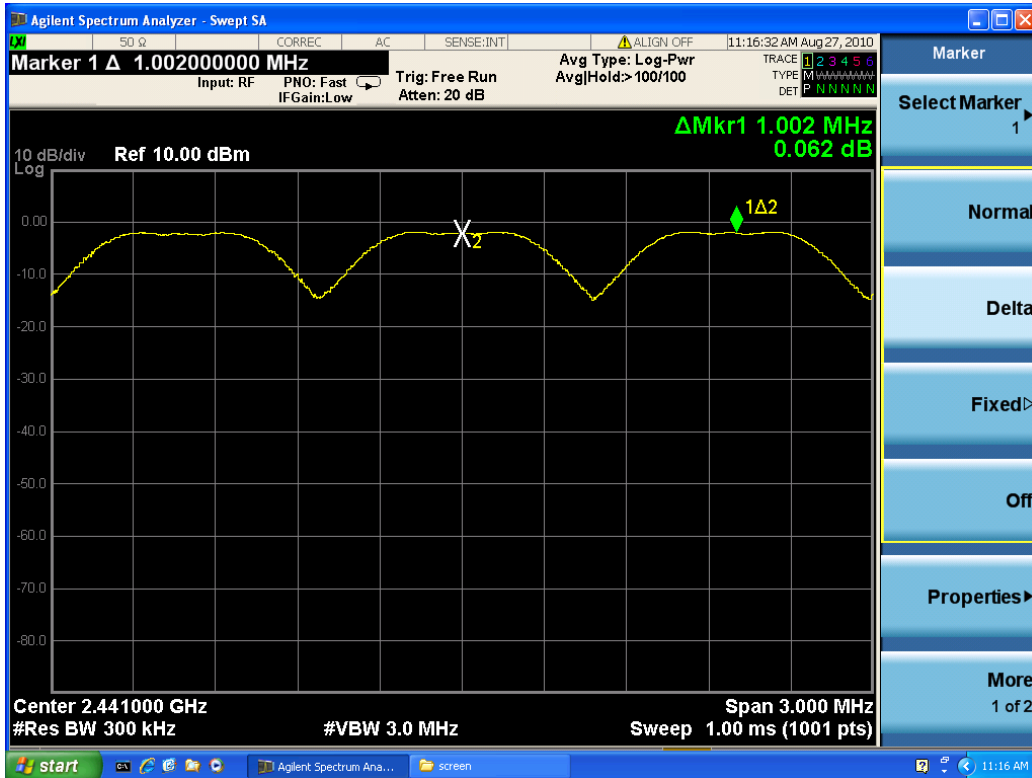

Carrier frequency (MHz): 2441
Channel No.:39



Carrier frequency (MHz): 2480
Channel No.:78

TA Technology (Shanghai) Co., Ltd.
Test Report

Registration Num:428261

Report No.: RZA2010-1332RF15C-R1

Page 18 of 62

2.5. Time of Occupancy (Dwell Time)

Ambient condition

Temperature	Relative humidity	Pressure
23°C ~25°C	45%~50%	101.5kPa

Methods of Measurement

The Equipment Under Test (EUT) was set up in a shielded room to perform the dwell time measurements. The EUT was connected to the spectrum analyzer and Bluetooth test set via a power splitter with a known loss. RBW is set to 1MHz and VBW is set to 3MHz on spectrum analyzer. The time slot length is measured of three different packet types, which are available in the Bluetooth technology. Those are DH1, DH3 and DH5 packets. The dwell time is calculated by:

Dwell time = time slot length * hop rate * 0.4s with:

- hop rate=1600 * 1/s for DH1 packet =1600
- hop rate=1600/3 * 1/s for DH3 packet =533.33
- hop rate=1600/5 * 1/s for DH5 packet =320

Test Setup

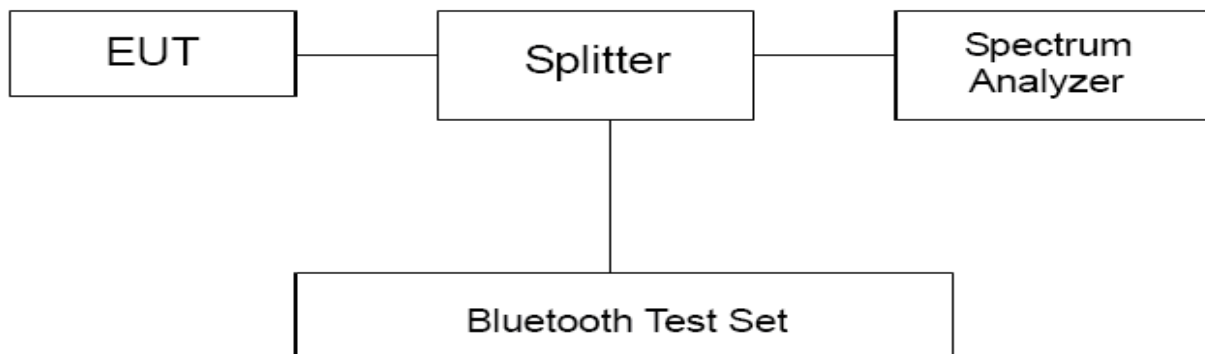

Limits

Rule Part 22.913(a) specifies that " Frequency hopping systems in the 2400–2483.5 MHz band shall use at least 15 channels. The average time of occupancy on any channel shall not be greater than 0.4 seconds within a period of 0.4 seconds multiplied by the number of hopping channels employed.."

Dwell time	≤ 400ms
------------	---------

Measurement Uncertainty

The assessed measurement uncertainty to ensure 95% confidence level for the normal distribution is with the coverage factor $k = 2$. $U_{DH1} = 0.64\text{ms}$, $U_{DH3} = 0.80\text{ms}$, $U_{DH5} = 0.70\text{ms}$.

Test Results:

CH 39

Packet type	hop rate (1/s)	Time slot length(ms)	Dwell time (ms)	Limit (ms)	Conclusion
DH1	1600	0.4318	276.35	400	PASS
DH3	533.33	1.693	361.17	400	PASS
DH5	320	2.929	374.91	400	PASS

Note: Dwell time = time slot length * hop rate * 0.4s

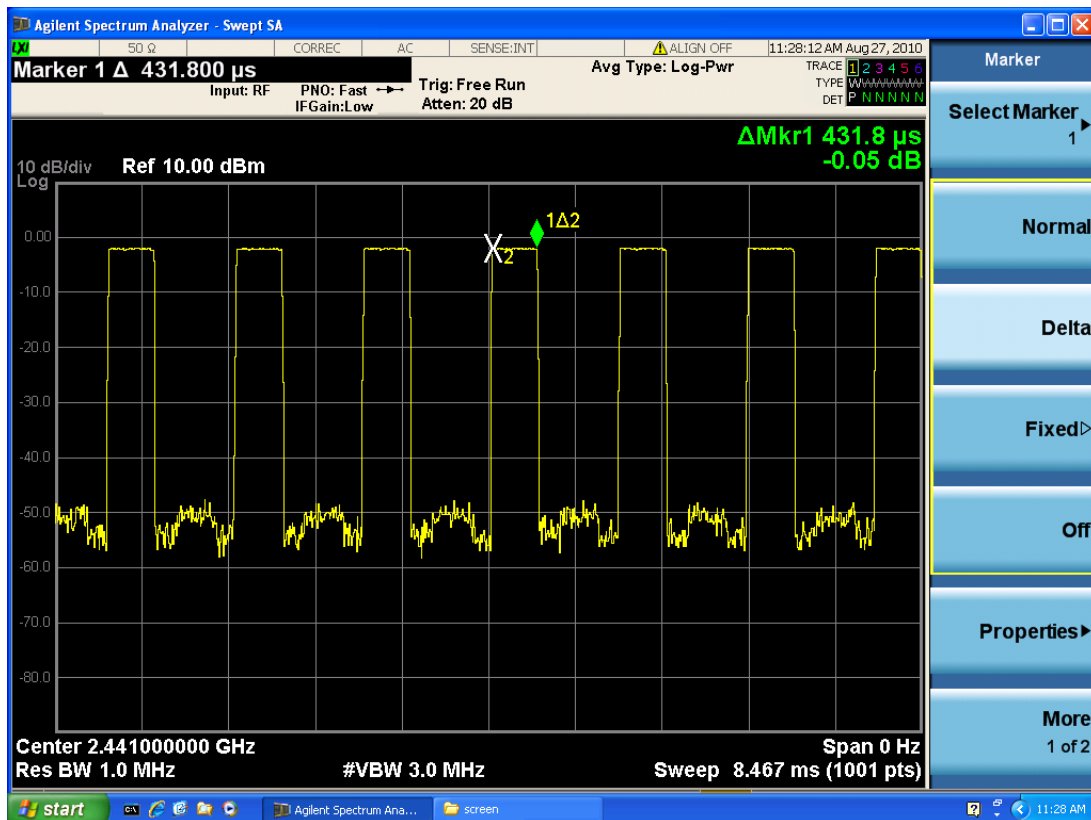

Carrier frequency (MHz): 2441,DH1

TA Technology (Shanghai) Co., Ltd. Test Report

Registration Num:428261

Report No.: RZA2010-1332RF15C-R1

Page 20 of 62

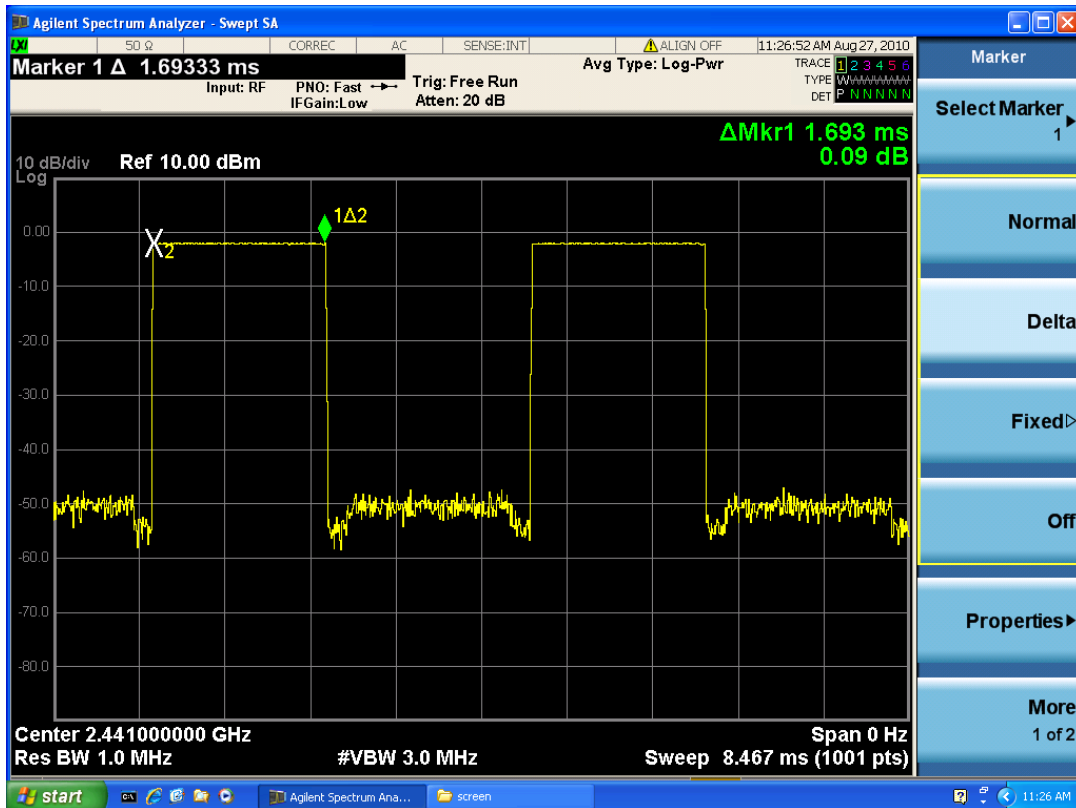

Carrier frequency (MHz): 2441,DH3

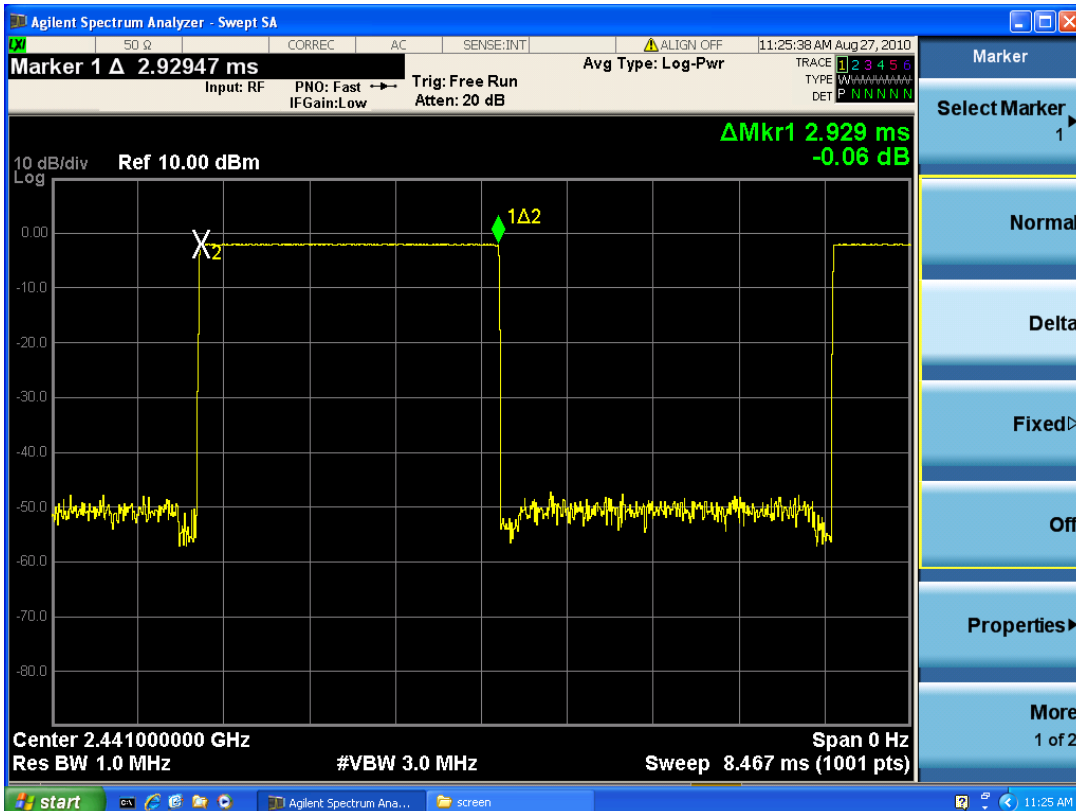

Carrier frequency (MHz): 2441,DH5

2.6. Band Edge Compliance

Ambient condition

Temperature	Relative humidity	Pressure
23°C ~25°C	45%~50%	101.5kPa

Method of Measurement

The Equipment Under Test (EUT) was set up in a shielded room to perform the spurious emissions measurements. The EUT was connected to the spectrum analyzer and Bluetooth test set via a power splitter with a known loss. The band edge of the lowest and highest channels were measured. The peak detector is used. RBW is set to 1MHz and VBW is set to 3MHz on spectrum analyzer. Spectrum analyzer plots are included on the following pages. EUT test for Hopping On mode and Hopping Off mode.

Test Setup

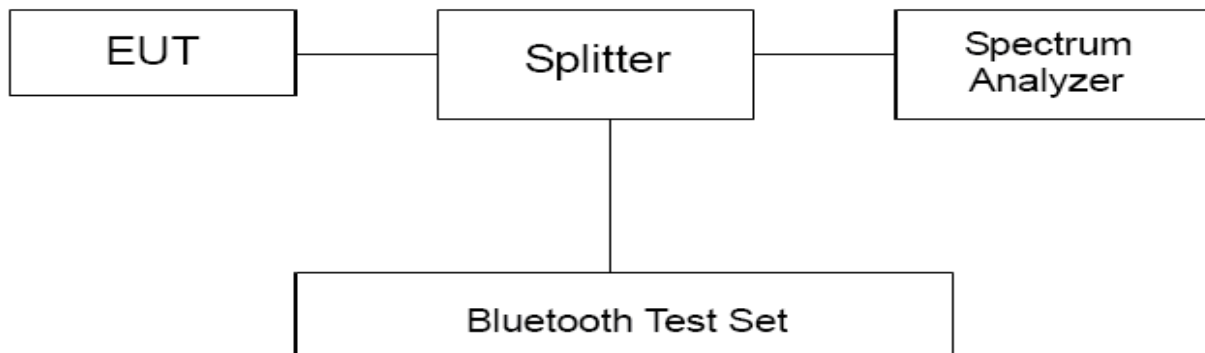

Limits

Rule Part 15.247(d) specifies that “In any 100 kHz bandwidth outside the frequency band in which the spread spectrum or digitally modulated intentional radiator is operating, the radio frequency power that is produced by the intentional radiator shall be at least 20 dB below that in the 100 kHz bandwidth within the band that contains the highest level of the desired power, based on either an RF conducted or a radiated measurement, provided the transmitter demonstrates compliance with the peak conducted power limits.”

Measurement Uncertainty

The assessed measurement uncertainty to ensure 95% confidence level for the normal distribution is with the coverage factor $k = 1.96$.

Frequency	Uncertainty
2GHz-3GHz	1.407 dB

TA Technology (Shanghai) Co., Ltd. Test Report

Registration Num:428261

Report No.: RZA2010-1332RF15C-R1

Page 22 of 62

Test Results: PASS

Hopping On

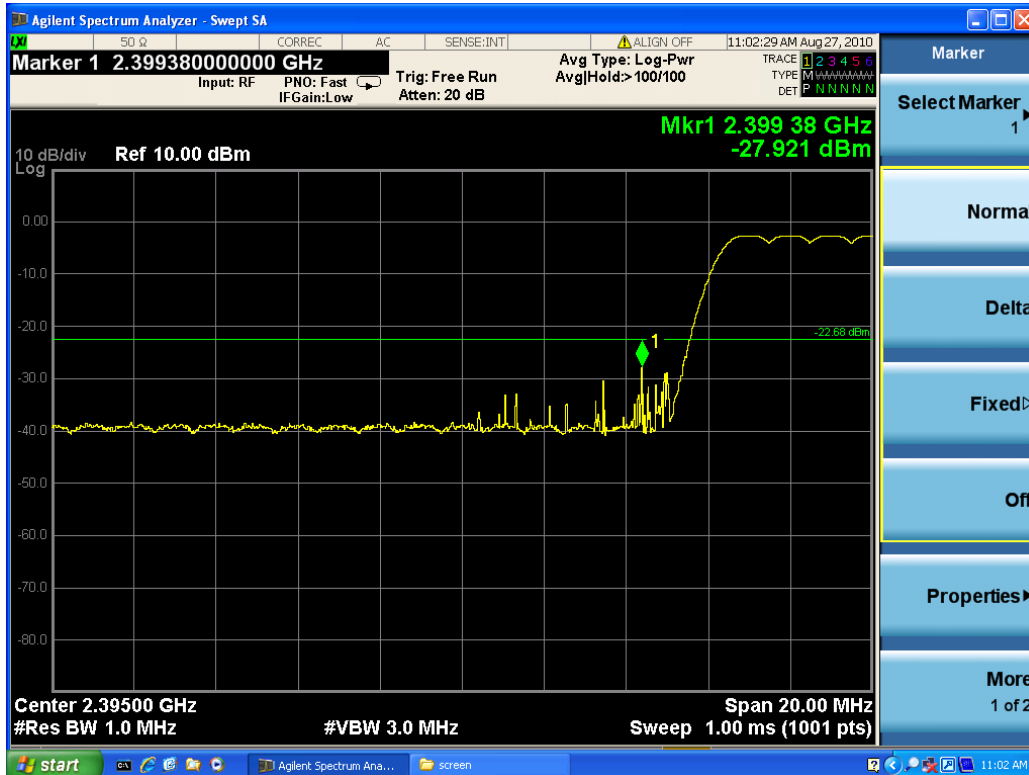

Carrier frequency (MHz): 2402

Channel No.:0

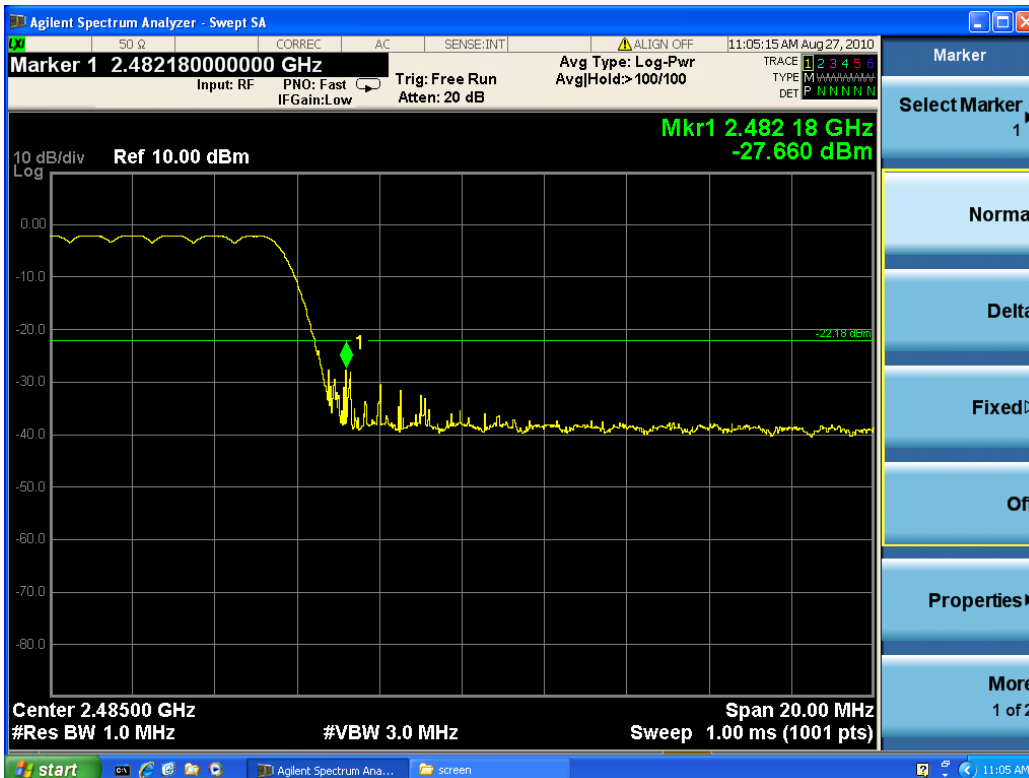

Carrier frequency (MHz): 2480

Channel No.:78

TA Technology (Shanghai) Co., Ltd. Test Report

Registration Num:428261

Report No.: RZA2010-1332RF15C-R1

Page 23 of 62

Hopping Off

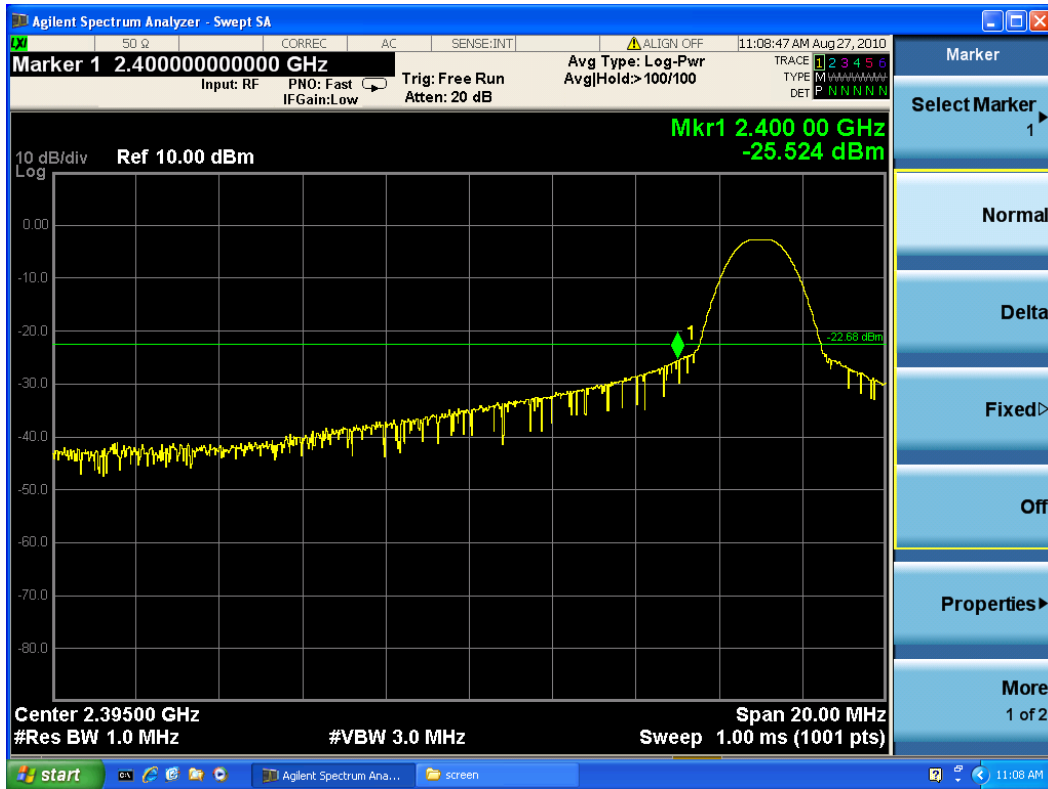

Carrier frequency (MHz): 2402

Channel No.:0

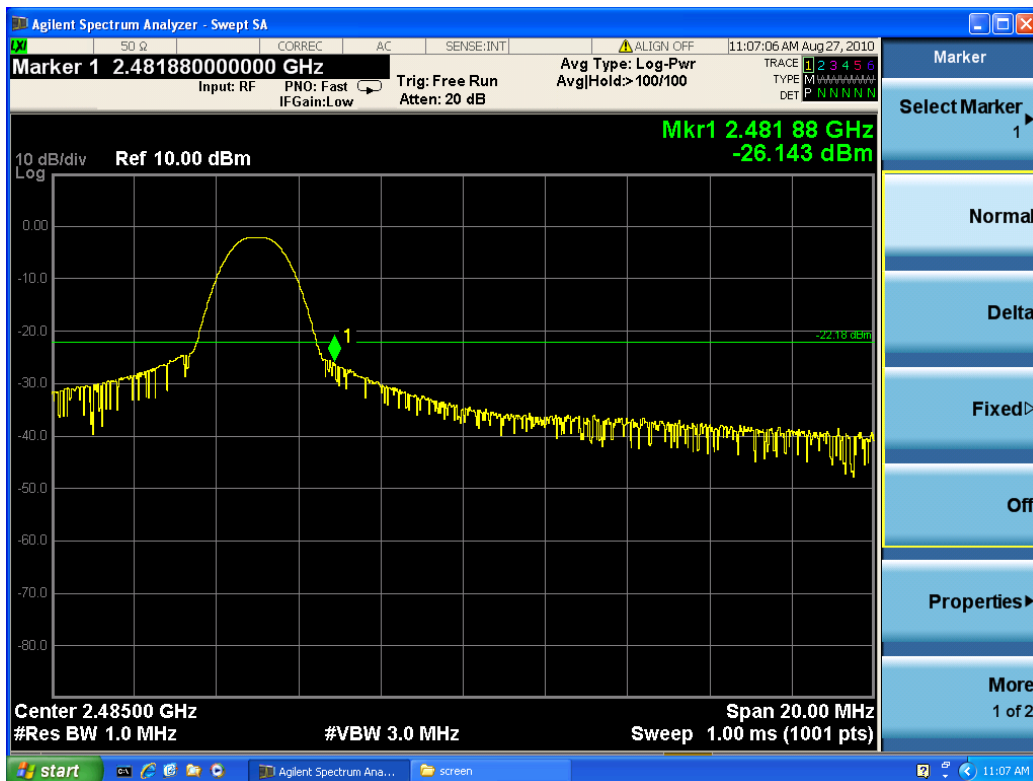

Carrier frequency (MHz): 2480

Channel No.:78

TA Technology (Shanghai) Co., Ltd. Test Report

Registration Num:428261

Report No.: RZA2010-1332RF15C-R1

Page 24 of 62

2.7. Spurious Radiated Emissions in the Restricted Band

Ambient condition

Temperature	Relative humidity	Pressure
23°C ~25°C	45%~50%	101.5kPa

The Equipment Under Test (EUT) was set up on a non-conductive table in the semi-anechoic chamber. The test was performed at the distance of 3 m between the EUT and the receiving antenna. The turntable shall be rotated from 0 to 360 degrees for detecting the maximum of radiated spurious signal level. The measurements shall be repeated with orthogonal polarization of the test antenna. The data of cable loss and antenna factor has been calibrated in full testing frequency range before the testing.

Set the spectrum analyzer in the following:

- (a) PEAK: RBW=VBW=1MHz / Sweep=AUTO
- (b) AVERAGE: RBW=1MHz / VBW=10Hz / Sweep=AUTO

This test method can refer to **DA00-705**.

EUT in X-axis orientation is the worst case, the test is only for this case.

The test is in transmit mode.

Test setup

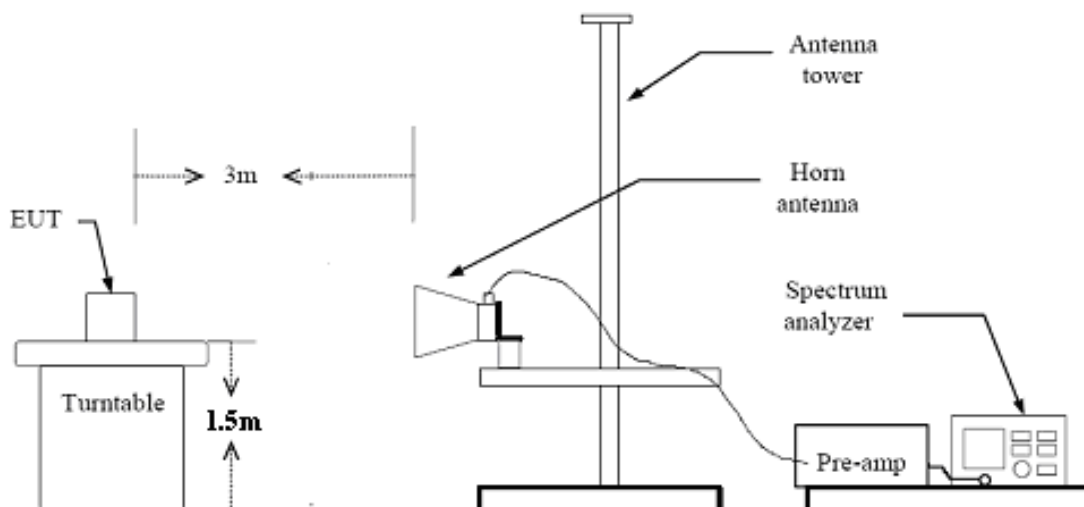

TA Technology (Shanghai) Co., Ltd.

Test Report

Registration Num:428261

Report No.: RZA2010-1332RF15C-R1

Page 25 of 62

Limits

Spurious Radiated Emissions are permitted in any of the frequency bands listed below:

MHz	MHz	MHz	GHz
0.090 - 0.110	16.42 - 16.423	399.9 - 410	4.5 - 5.15
¹ 0.495 - 0.505	16.69475 - 16.69525	608 - 614	5.35 - 5.46
2.1735 - 2.1905	16.80425 - 16.80475	960 - 1240	7.25 - 7.75
4.125 - 4.128	25.5 - 25.67	1300 - 1427	8.025 - 8.5
4.17725 - 4.17775	37.5 - 38.25	1435 - 1626.5	9.0 - 9.2
4.20725 - 4.20775	73 - 74.6	1645.5 - 1646.5	9.3 - 9.5
6.215 - 6.218	74.8 - 75.2	1660 - 1710	10.6 - 12.7
6.26775 - 6.26825	108 - 121.94	1718.8 - 1722.2	13.25 - 13.4
6.31175 - 6.31225	123 - 138	2200 - 2300	14.47 - 14.5
8.291 - 8.294	149.9 - 150.05	2310 - 2390	15.35 - 16.2
8.362 - 8.366	156.52475 - 156.52525	2483.5 - 2500	17.7 - 21.4
8.37625 - 8.38675	156.7 - 156.9	2690 - 2900	22.01 - 23.12
8.41425 - 8.41475	162.0125 - 167.17	3260 - 3267	23.6 - 24.0
12.29 - 12.293	167.72 - 173.2	3332 - 3339	31.2 - 31.8
12.51975 - 12.52025	240 - 285	3345.8 - 3358	36.43 - 36.5
12.57675 - 12.57725	322 - 335.4	3600 - 4400	(²)
13.36 - 13.41			

Limit in restricted band

Frequency of emission (MHz)	Field strength(uV/m)	Field strength(dBuV/m)
30-88	100	40
88-216	150	43.5
216-960	200	46
Above960	500	54

§15.35(b)

There is also a limit on the radio frequency emissions, as measured using instrumentation with a peak detector function, corresponding to 20 dB above the maximum permitted average limit.

Peak Limit=74 dBuV/m

Average Limit=54 dBuV/m

Measurement Uncertainty

The assessed measurement uncertainty to ensure 95% confidence level for the normal distribution is with the coverage factor $k = 1.96$. $U=3.92$ dB.

Test Results:

Channel 0

lower band edge Peak-CH 0

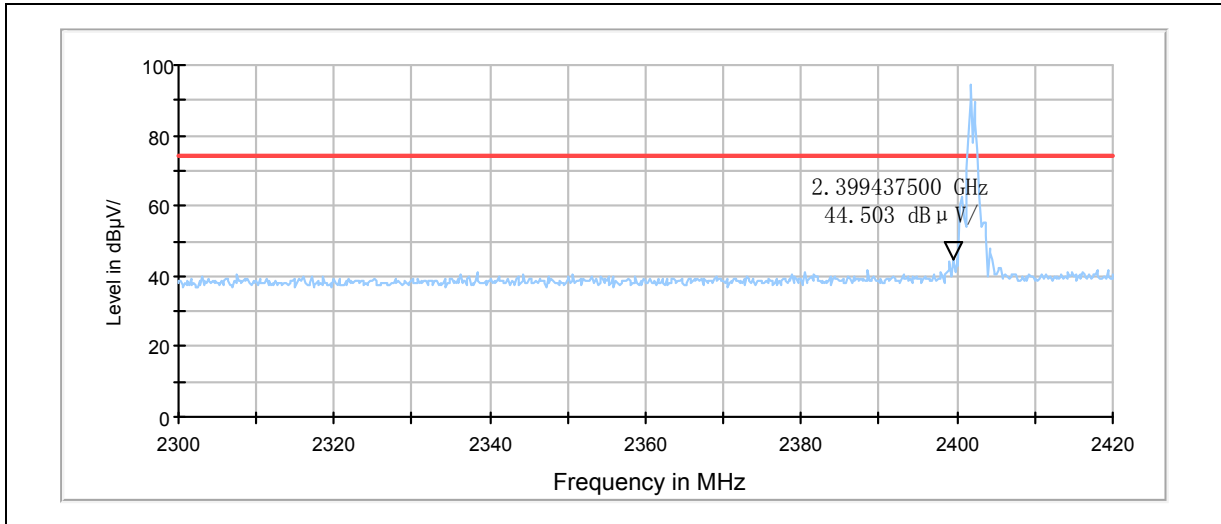

Note: The signal beyond the limit is carrier

lower band edge average-CH 0

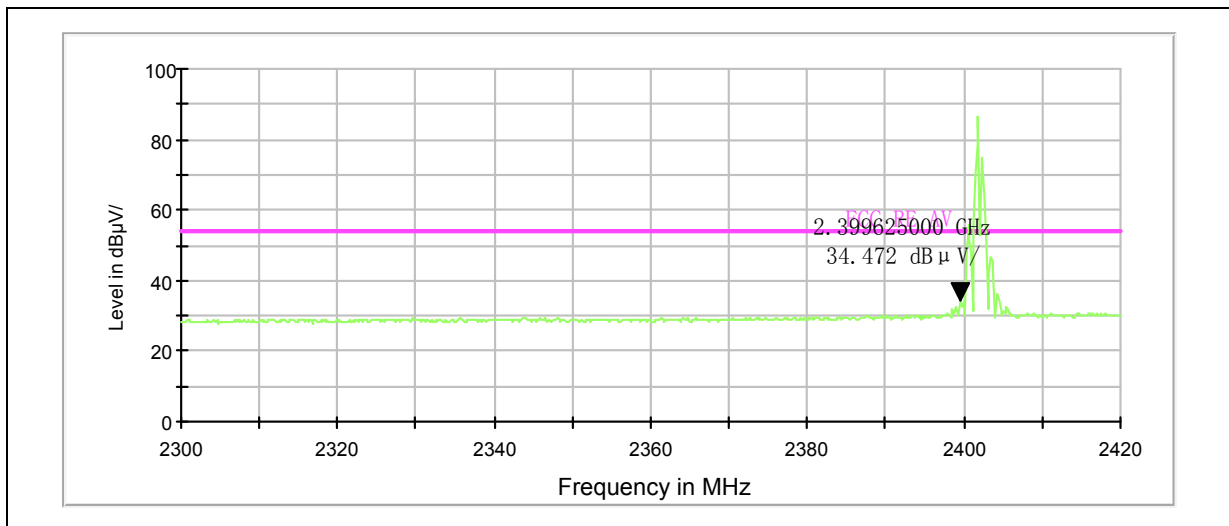

Note: The signal beyond the limit is carrier

Channel 78

Higher band edge Peak-CH 78

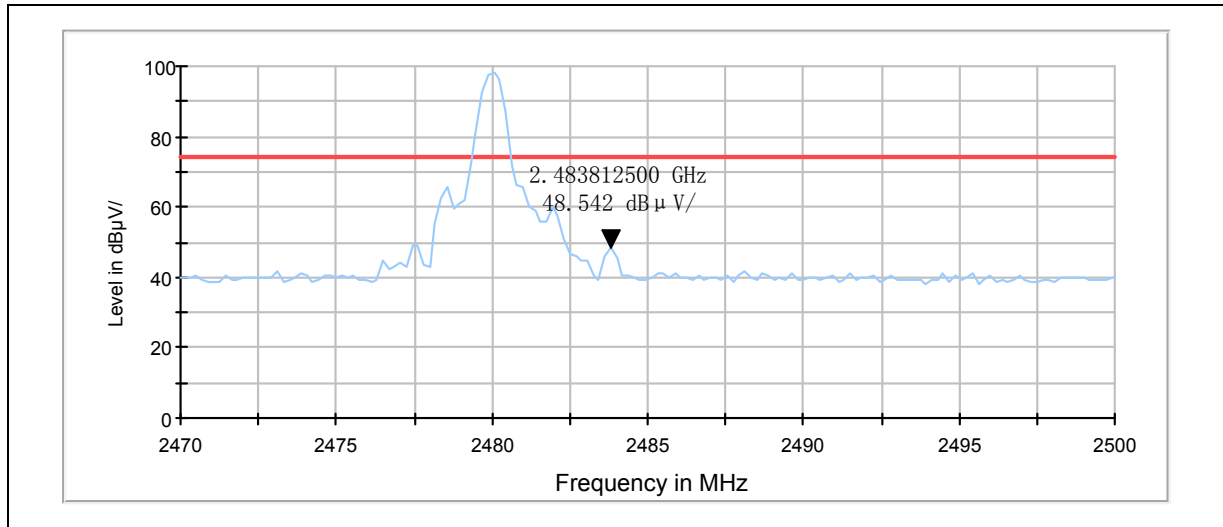

Note: The signal beyond the limit is carrier

Higher band edge average-CH 78

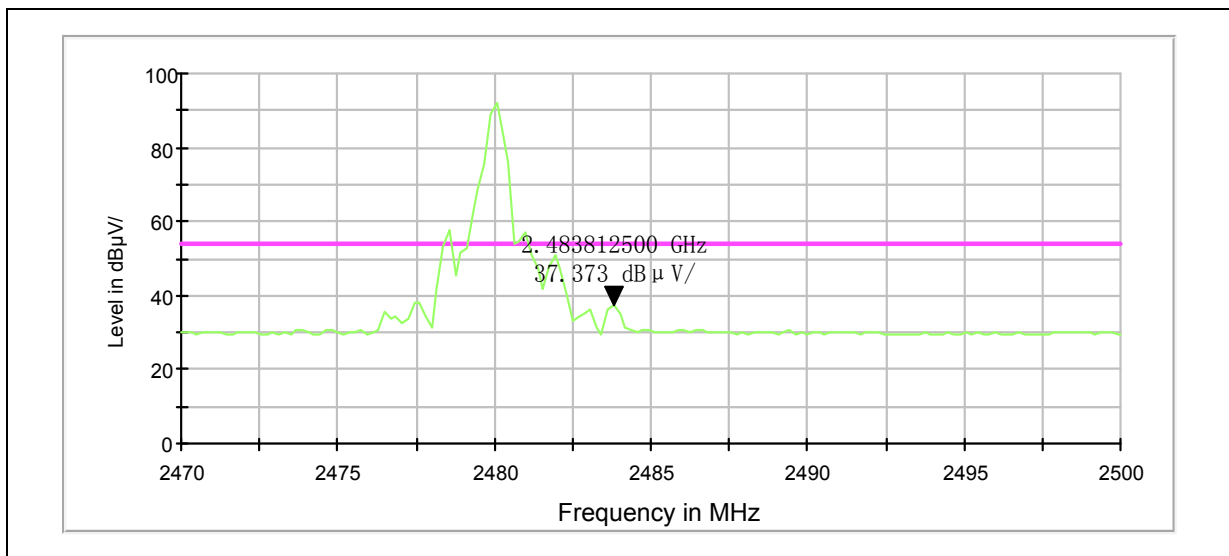

Note: The signal beyond the limit is carrier

Channel	Frequency (MHz)	Detector	Level (dBµV/m)	Limit (dBµV/m)	Margin (dB)
0	2399.4375	PK	44.503	74	29.497
	2399.6250	AV	34.472	54	19.528
78	2483.8125	PK	48.542	74	25.458
	2483.8125	AV	37.373	54	16.627

2.8. Number of hopping Frequency

Ambient condition

Temperature	Relative humidity	Pressure
23°C ~25°C	45%~50%	101.5kPa

Method of Measurement

The Equipment Under Test (EUT) was set up in a shielded room to perform the spurious emissions measurements. The EUT was connected to the spectrum analyzer and Bluetooth test set via a power splitter with a known loss. RBW is set to 300kHz and VBW is set to 3MHz on spectrum analyzer. Set EUT on Hopping on mode.

Test setup

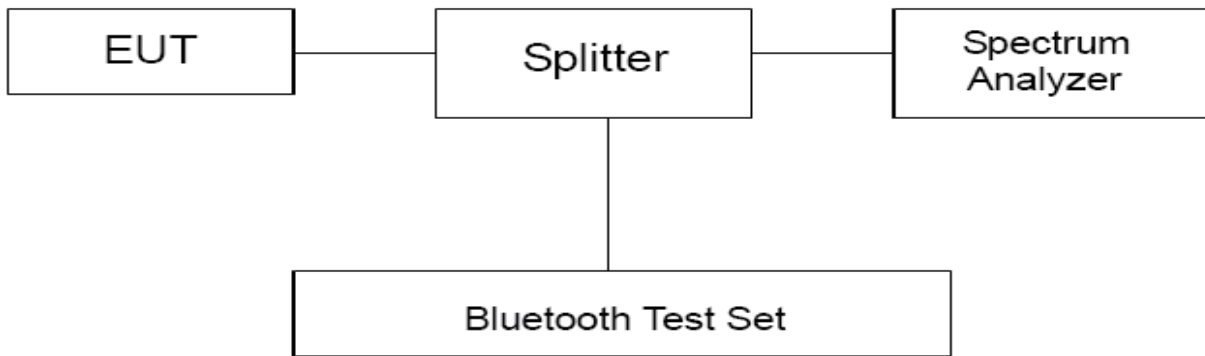

Limits

Rule Part 15.247(a) (1) (iii) specifies that” Frequency hopping systems in the 2400–2483.5 MHz band shall use at least 15 channels..”.

Limits	\geq 15 channels
--------	--------------------

Test Results:

Number of hopping channels	conclusion
79	PASS

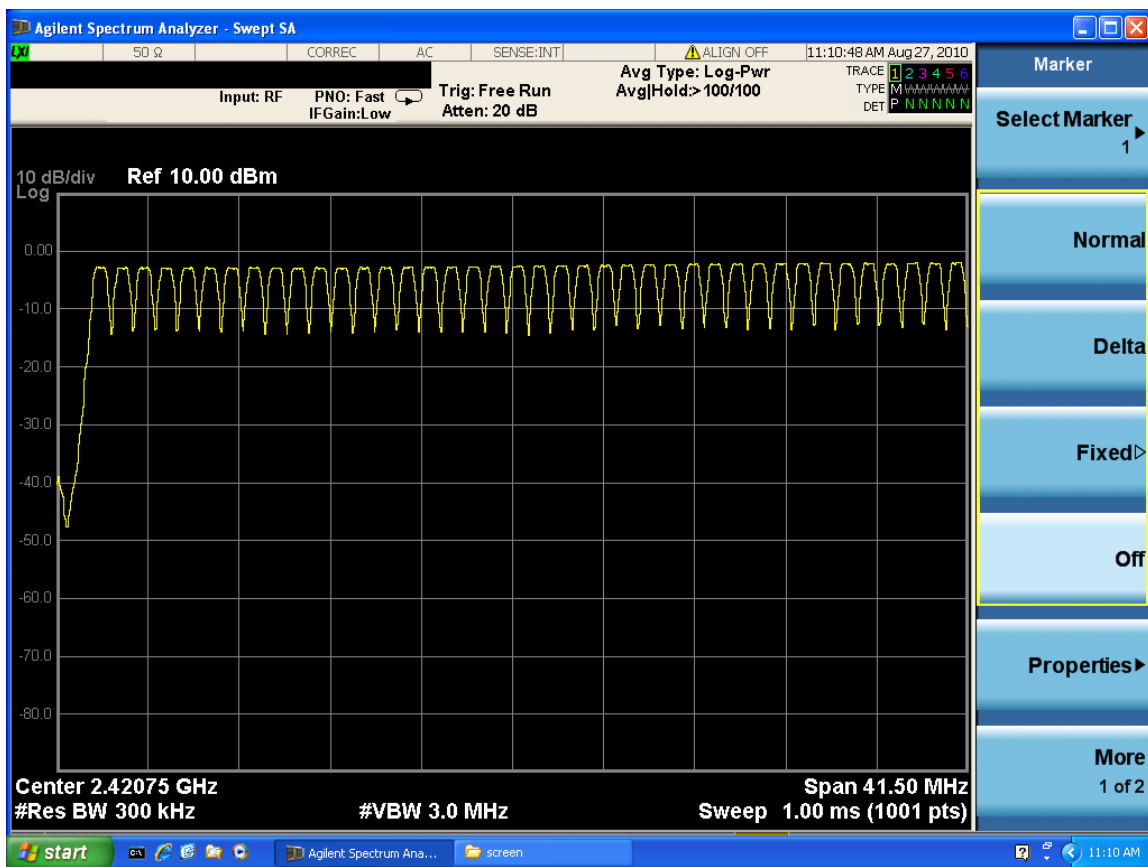

2400 MHz – 2441 MHz

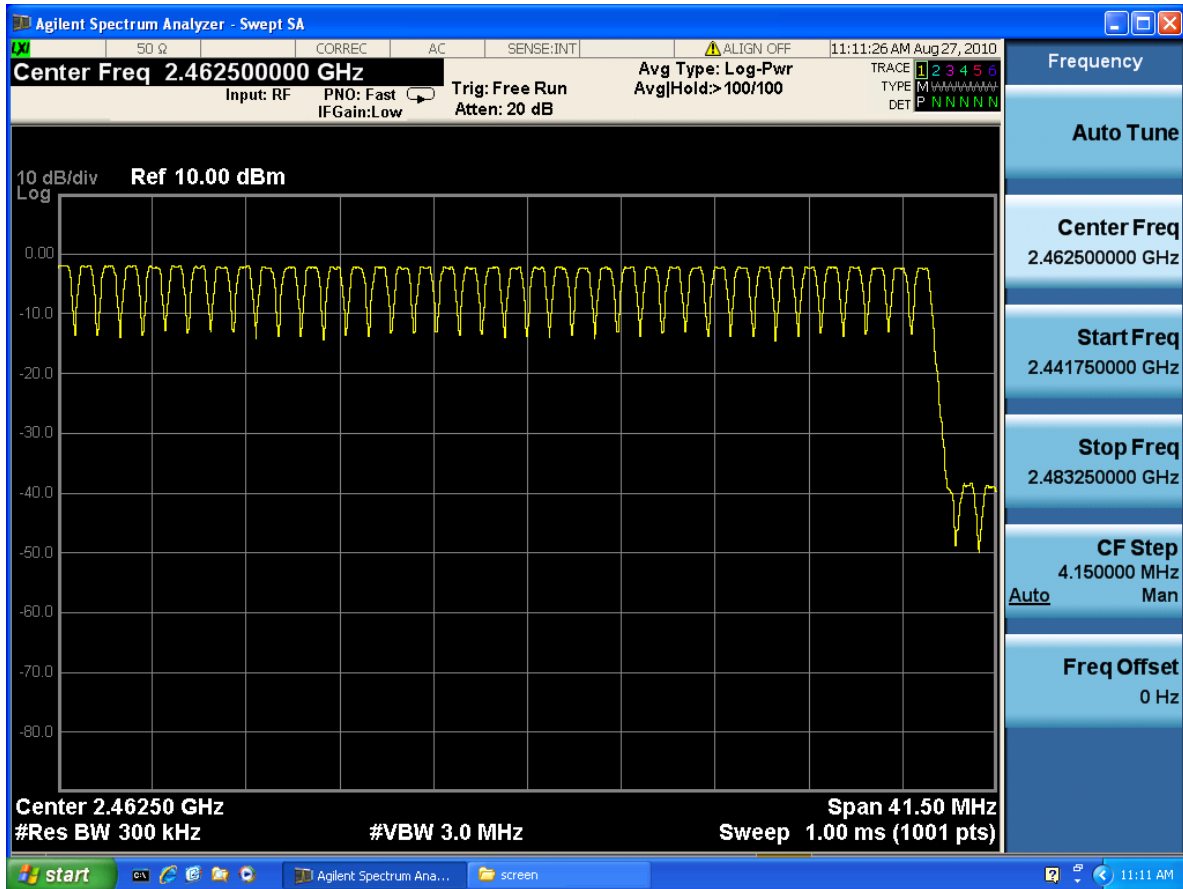

2441 MHz – 2483.5 MHz

2.9. Spurious RF Conducted Emissions

Ambient condition

Temperature	Relative humidity	Pressure
23°C ~25°C	45%~50%	101.5kPa

Method of Measurement

The EUT was connected to the spectrum analyzer and Bluetooth test set via a power splitter with a known loss. The spectrum analyzer scans from 30MHz to 26GHz. The peak detector is used. RBW and VBW are set to 100 kHz, Sweep is set to ATUO.

The test is in transmit mode.

Test setup

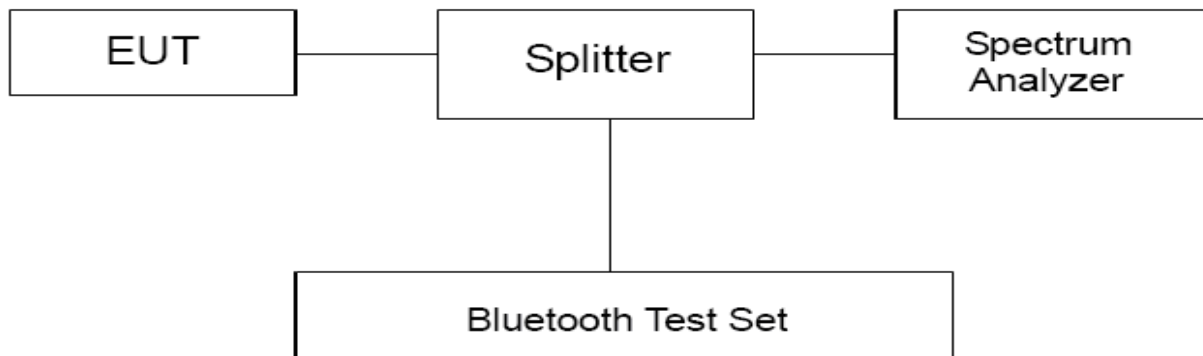

Limits

Rule Part 15.247(d) specifies that "In any 100 kHz bandwidth outside the frequency band in which the spread spectrum intentional radiator is operating, the radio frequency power that is produced by the intentional radiator shall be at least 20 dB below that in the 100 kHz bandwidth within the band that contains the highest level of the desired power."

Carrier frequency (MHz)	Reference value (dBm)	Limit
2402	-2.678	≤-22.678
2441	-1.851	≤-21.851
2480	-2.175	≤-22.175

Measurement Uncertainty

The assessed measurement uncertainty to ensure 95% confidence level for the normal distribution is with the coverage factor $k = 1.96$.

Frequency	Uncertainty
100kHz-2GHz	0.684 dB
2GHz-26GHz	1.407 dB

Test Results:

CH0:

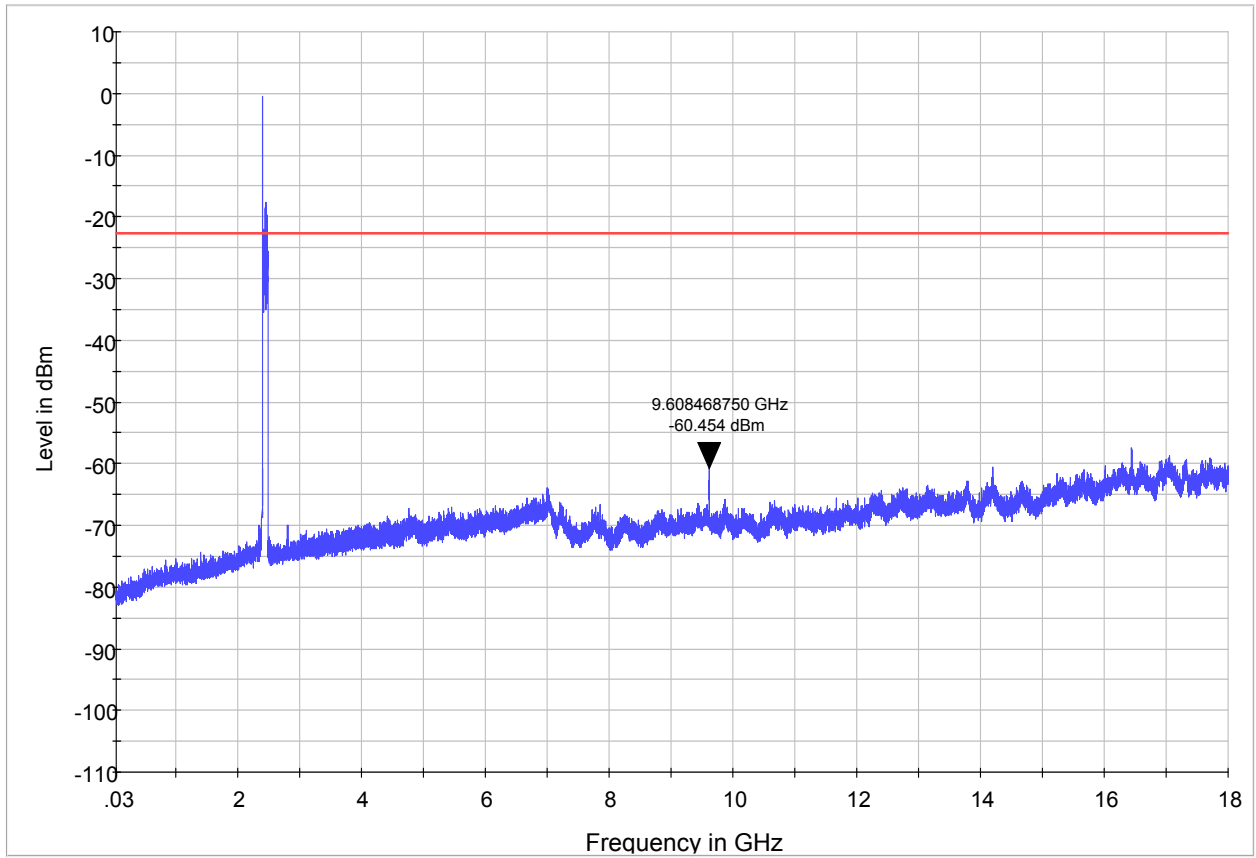

Note: The signal beyond the limit is carrier. Carrier frequency (MHz): 2402
Spurious RF conducted emissions from 30MHz to 18GHz

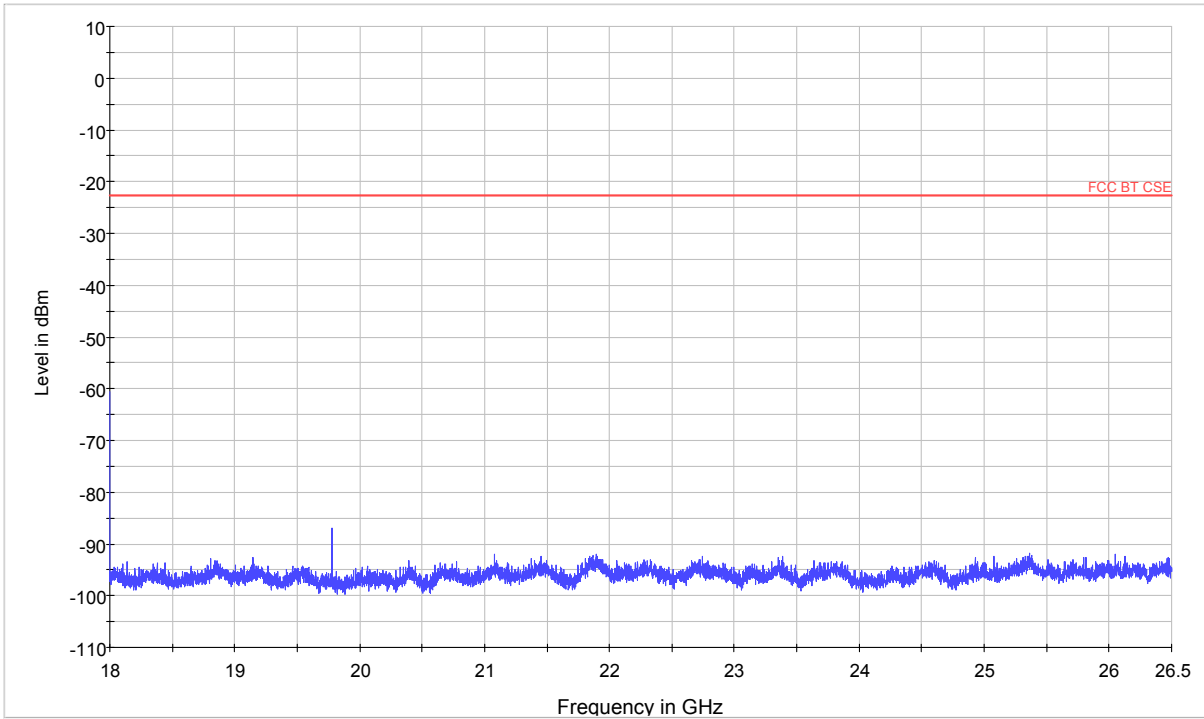

Spurious RF conducted emissions from 18GHz to 26.5GHz

Harmonic	TX ch.0 Frequency (MHz)	Level (dBm)	Limit (dBm)
2	4804	Nf	-22.678
3	7206	Nf	-22.678
4	9608.46875	-60.454	-22.678
5	12010	Nf	-22.678
6	14412	Nf	-22.678
7	16814	Nf	-22.678
8	19216	Nf	-22.678
9	21618	Nf	-22.678
10	24020	Nf	-22.678
Nf: noise floor			

Note: The other Spurious RF conducted emissions level is no more than noise floor.

CH39:

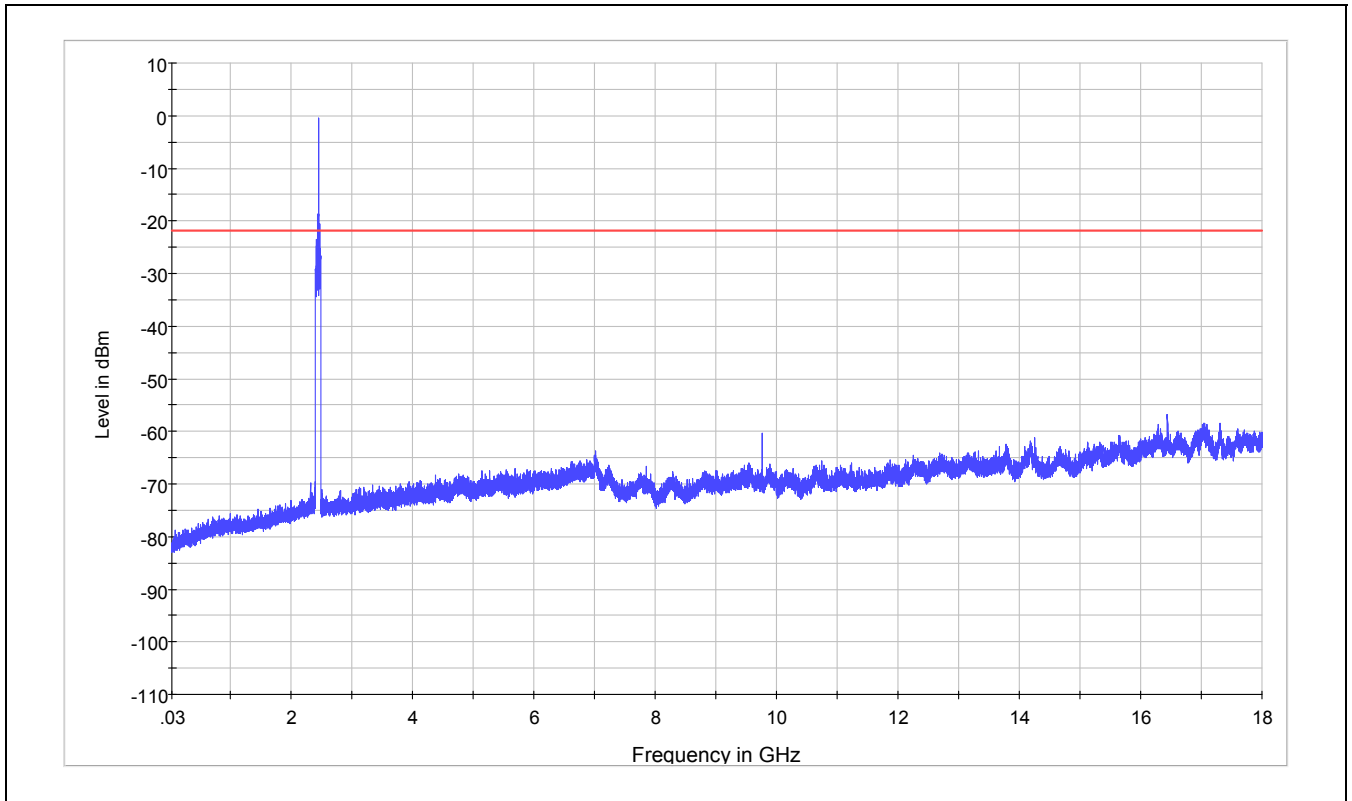

Note: The signal beyond the limit is carrier. Carrier frequency (MHz): 2441
Spurious RF conducted emissions from 30MHz to 18GHz

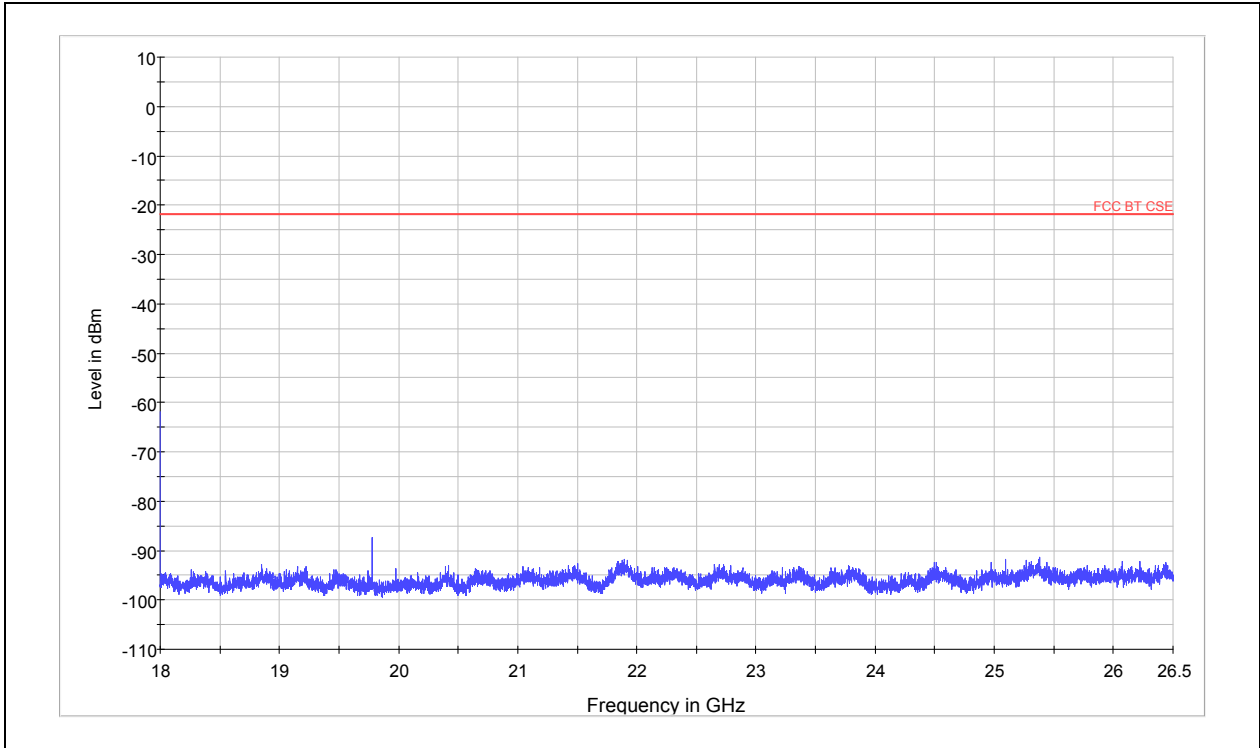

Spurious RF conducted emissions from 18GHz to 26.5GHz

Harmonic	TX ch.39 Frequency (MHz)	Level (dBm)	Limit (dBm)
2	4882	Nf	-21.851
3	7323	Nf	-21.851
4	9764	Nf	-21.851
5	12205	Nf	-21.851
6	14646	Nf	-21.851
7	17087	Nf	-21.851
8	19528	Nf	-21.851
9	21969	Nf	-21.851
10	24410	Nf	-21.851
Nf: noise floor			

Note: The other Spurious RF conducted emissions level is no more than noise floor.

CH78:

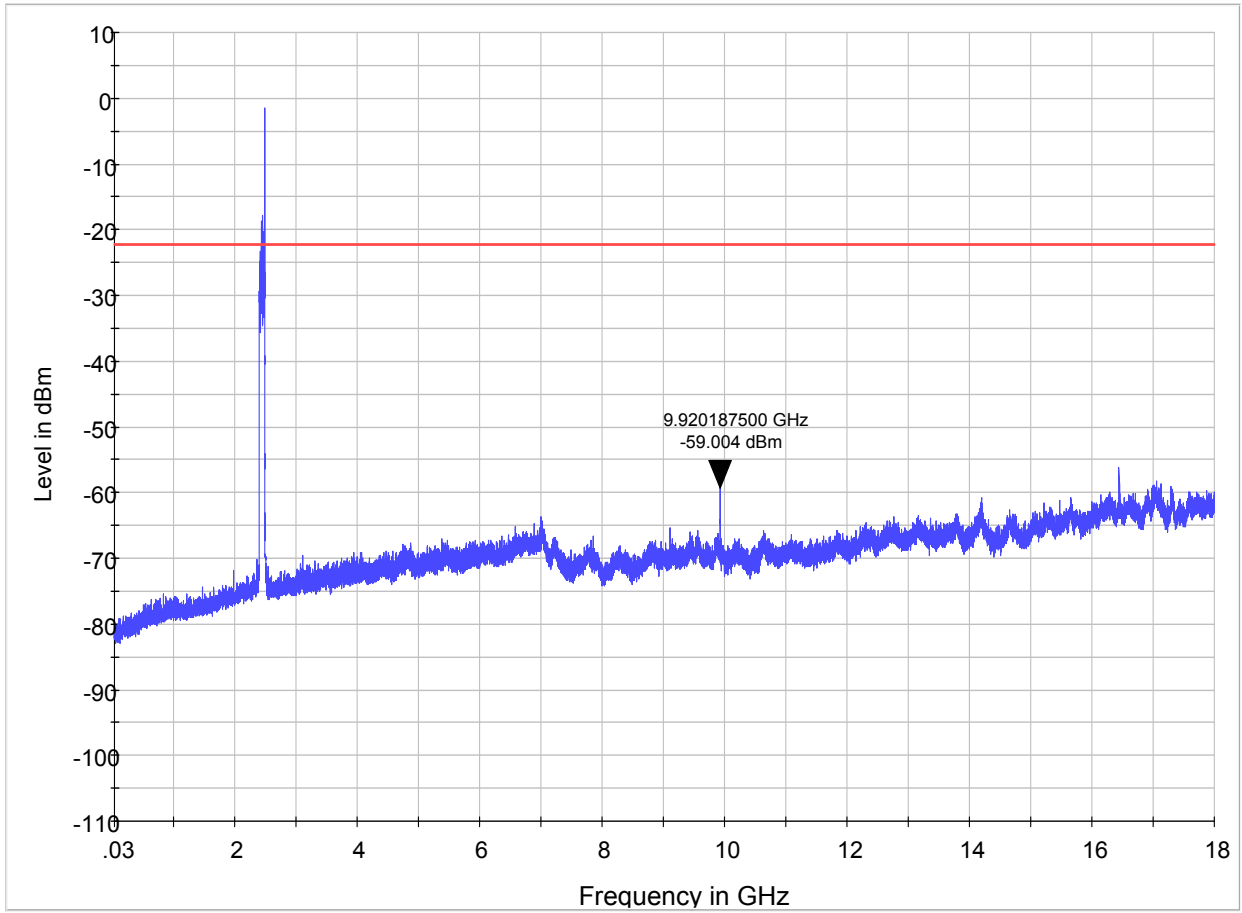

Note: The signal beyond the limit is carrier. Carrier frequency (MHz): 2480
Spurious RF conducted emissions from 30MHz to 18GHz

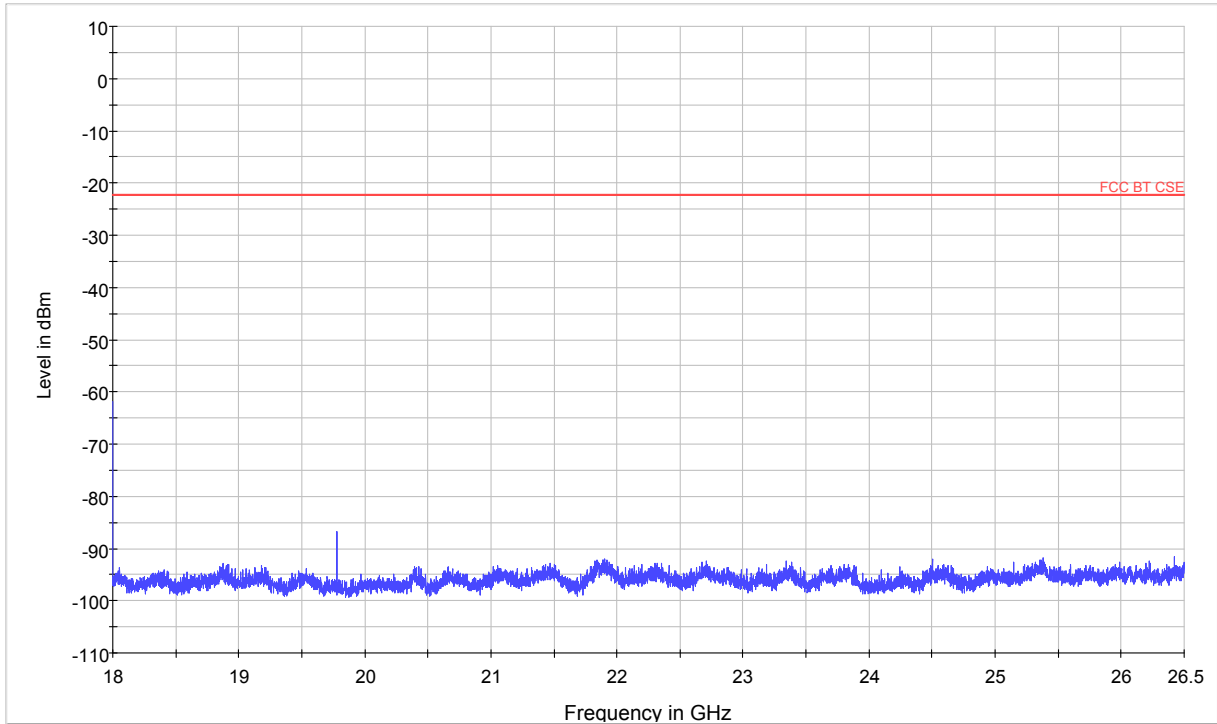

Spurious RF conducted emissions from 18GHz to 26.5GHz

Harmonic	TX ch.78 Frequency (MHz)	Level (dBm)	Limit (dBm)
2	4960	Nf	-22.175
3	7440	Nf	-22.175
4	9920.1875	-59.004	-22.175
5	12400	Nf	-22.175
6	14880	Nf	-22.175
7	17360	Nf	-22.175
8	19840	Nf	-22.175
9	22320	Nf	-22.175
10	24800	Nf	-22.175
Nf: noise floor			

Note: The other Spurious RF conducted emissions level is no more than noise floor.

2.10. Radiates Emission

Ambient condition

Temperature	Relative humidity	Pressure
23°C ~25°C	45%~50%	102.5kPa

Method of Measurement

The test set-up was made in accordance to the general provisions of ANSI C63.4-2003. The Equipment Under Test (EUT) was set up on a non-conductive table in the semi-anechoic chamber. The test was performed at the distance of 3 m between the EUT and the receiving antenna. The radiated emissions measurements were made in a typical installation configuration. Sweep the whole frequency band through the range from 30MHz to 26GHz during the test, the height of receive antenna shall be moved from 1 to 4 meters, and the antenna shall be performed under horizontal and vertical polarization. The turntable shall be rotated from 0 to 360 degrees for detecting the maximum of radiated spurious signal level. The measurements shall be repeated with orthogonal polarization of the test antenna. The data of cable loss and antenna factor has been calibrated in full testing frequency range before the testing.

Set the spectrum analyzer in the following:

Below 1GHz:

RBW=100kHz / VBW=300kHz / Sweep=AUTO

Above 1GHz:

(a) PEAK: RBW=1MHz VBW=3MHz/ Sweep=AUTO

(b) AVERAGE: RBW=1MHz / VBW=10Hz / Sweep=AUTO

The test is in transmit mode.

Test setup

Below 1GHz

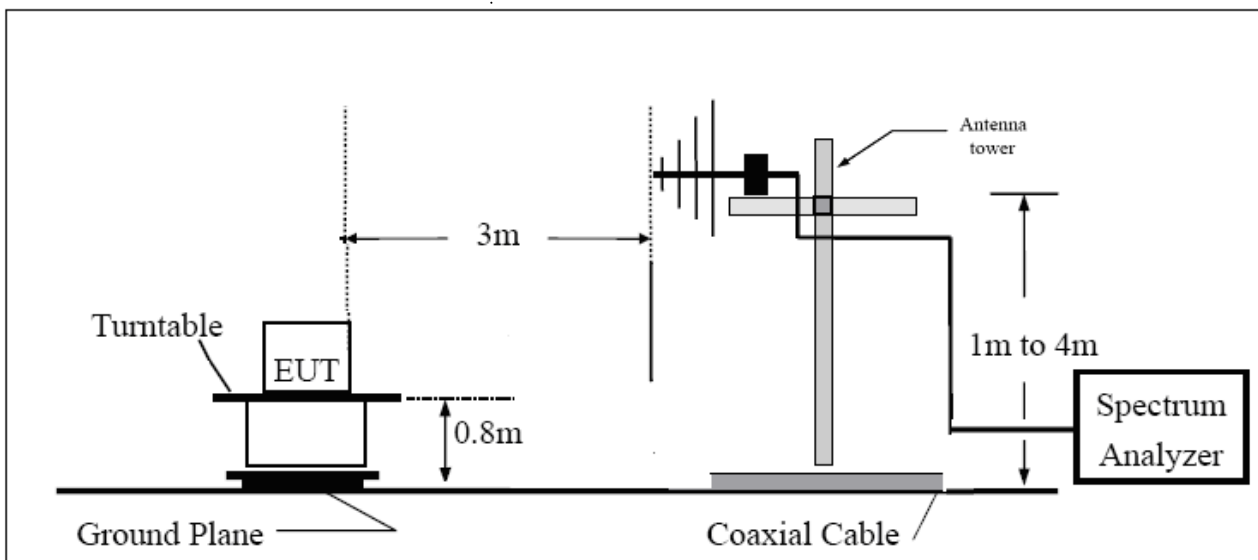

Above 1GHz

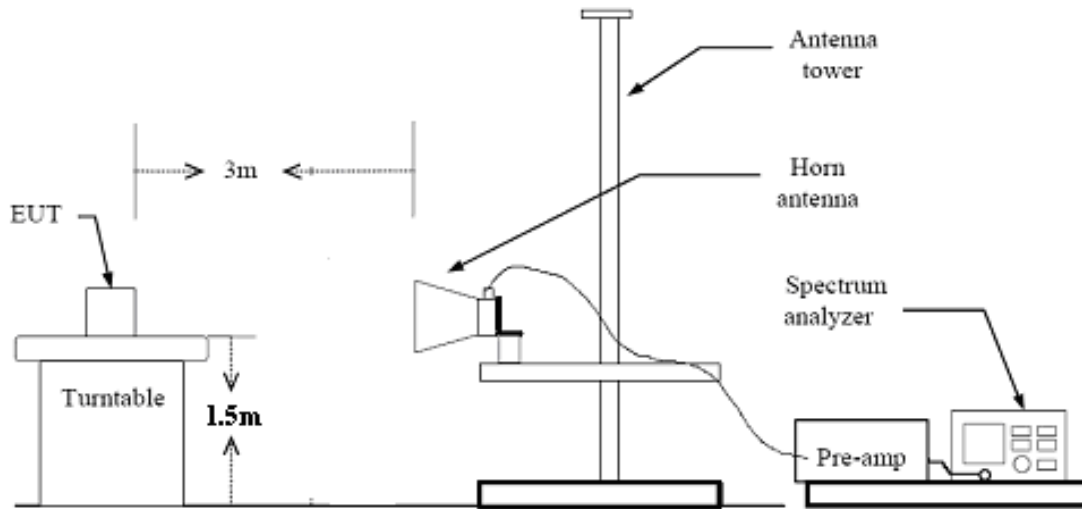

Limits

Rule Part 15.247(d) specifies that “In addition, radiated emissions which fall in the restricted bands, as defined in § 15.205(a), must also comply with the radiated emission limits specified in § 15.209(a) (see § 15.205(c)).”

Limit in restricted band

Frequency of emission (MHz)	Field strength(uV/m)	Field strength(dBuV/m)
30-88	100	40
88-216	150	43.5
216-960	200	46
Above 960	500	54

§15.35(b)

There is also a limit on the radio frequency emissions, as measured using instrumentation with a peak detector function, corresponding to 20 dB above the maximum permitted average limit.

Measurement Uncertainty

The assessed measurement uncertainty to ensure 95% confidence level for the normal distribution is with the coverage factor $k = 1.96$. $U=3.92$ dB.

Test result

Channel 0

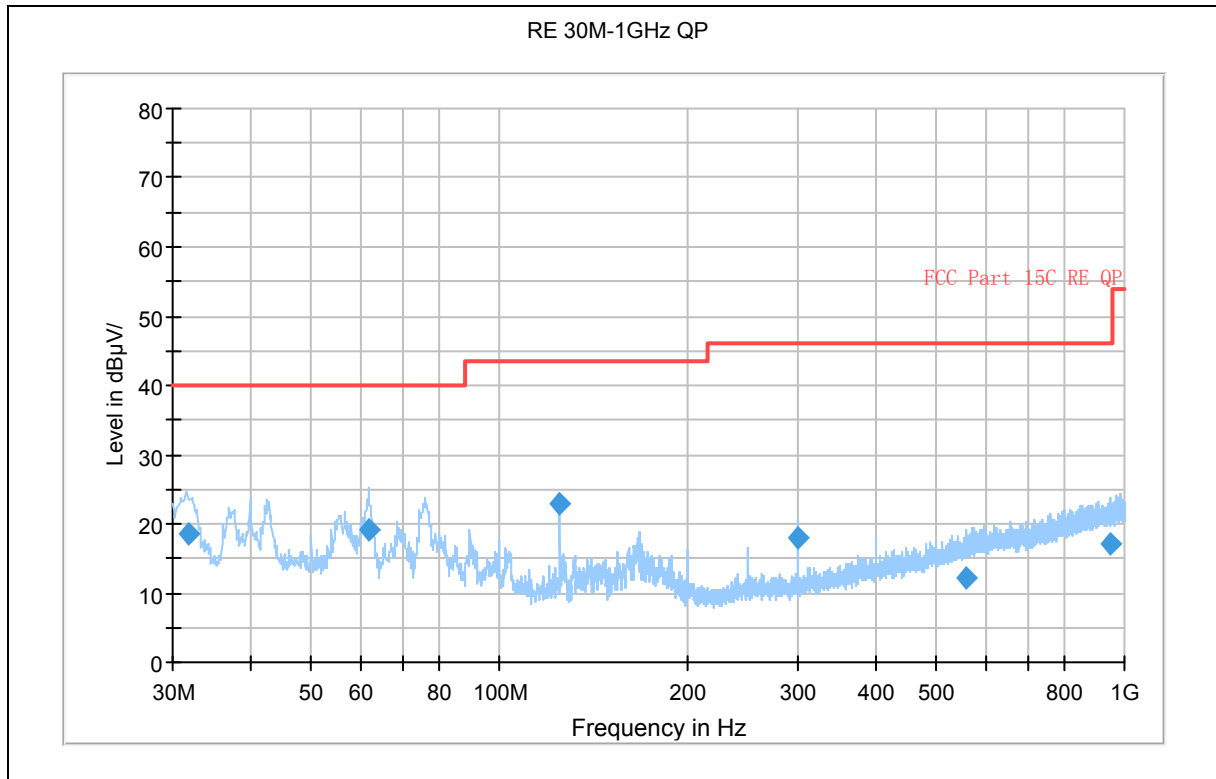

Radiates Emission from 30MHz to 1GHz

Frequency (MHz)	Quasi-Peak (dBuV/m)	Height (cm)	Polarization	Azimuth (deg)	Correct Factor (dB)	Margin (dB)	Limit (dBuV/m)
31.856250	18.5	116.0	Vertical	10.0	-24.3	21.5	40.0
61.768750	19.2	116.0	Vertical	16.0	-27.9	20.8	40.0
125.018750	22.9	100.0	Vertical	0.0	-31.6	20.6	43.5
300.023750	18.1	100.0	Vertical	287.0	-27.5	27.9	46.0
556.911250	12.3	175.0	Vertical	275.0	-21.8	33.7	46.0
950.572500	17.2	200.0	Vertical	164.0	-16.8	28.8	46.0

Note: All emissions level measured above 1GHz was more than 10dB below the limit

Peak

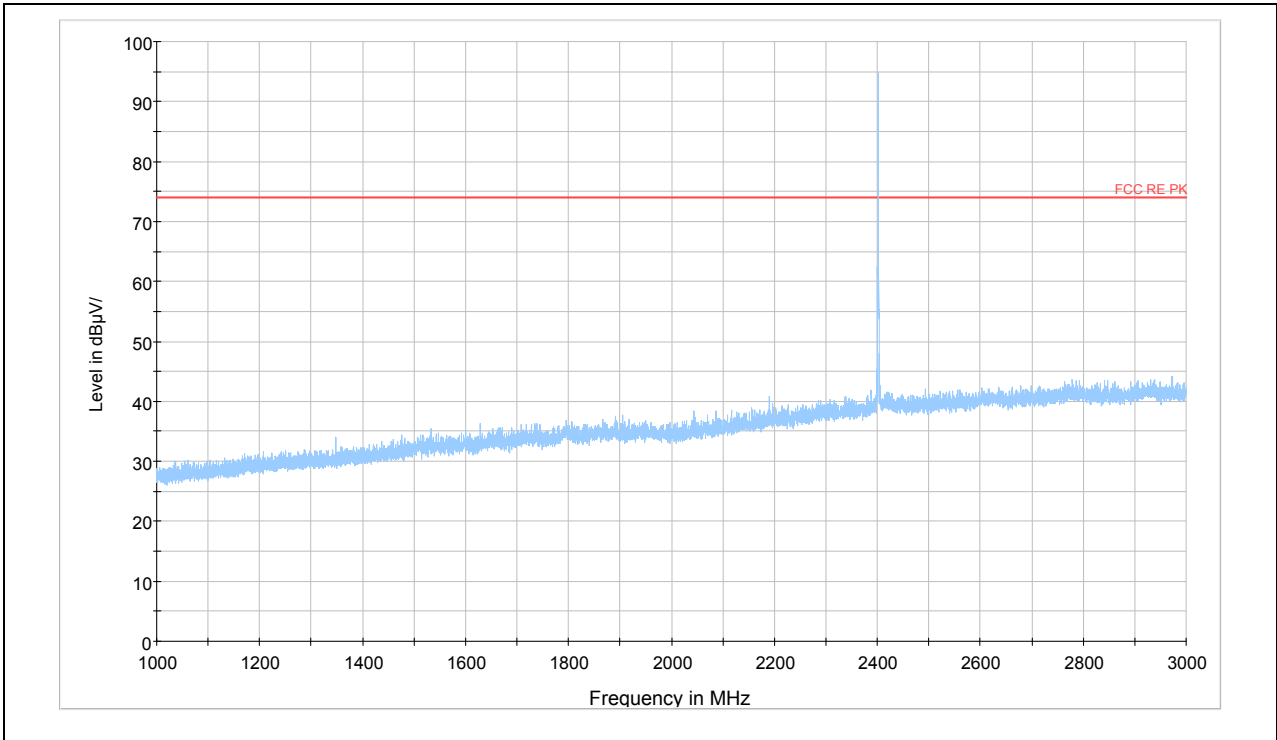

Note: The signal beyond the limit is carrier.
Radiates Emission from 1GHz to 3GHz

Average

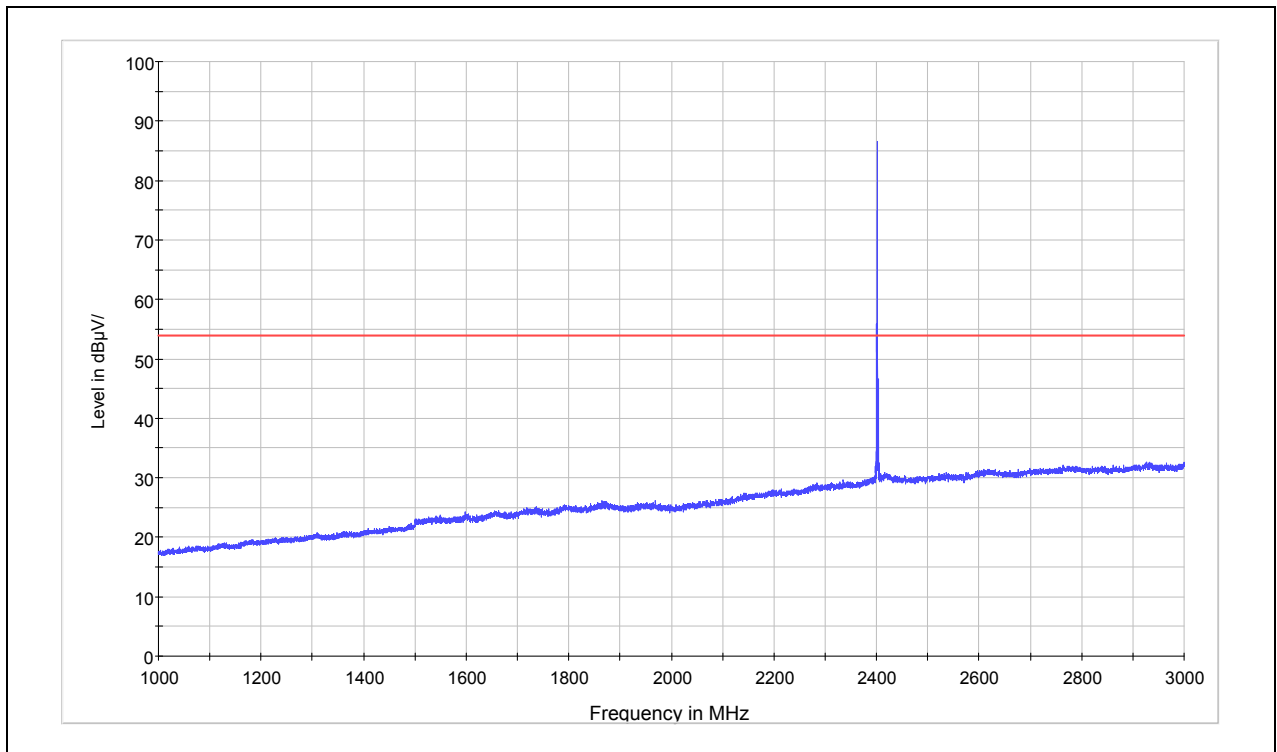

Note: The signal beyond the limit is carrier.
Radiates Emission from 1GHz to 3GHz

Peak

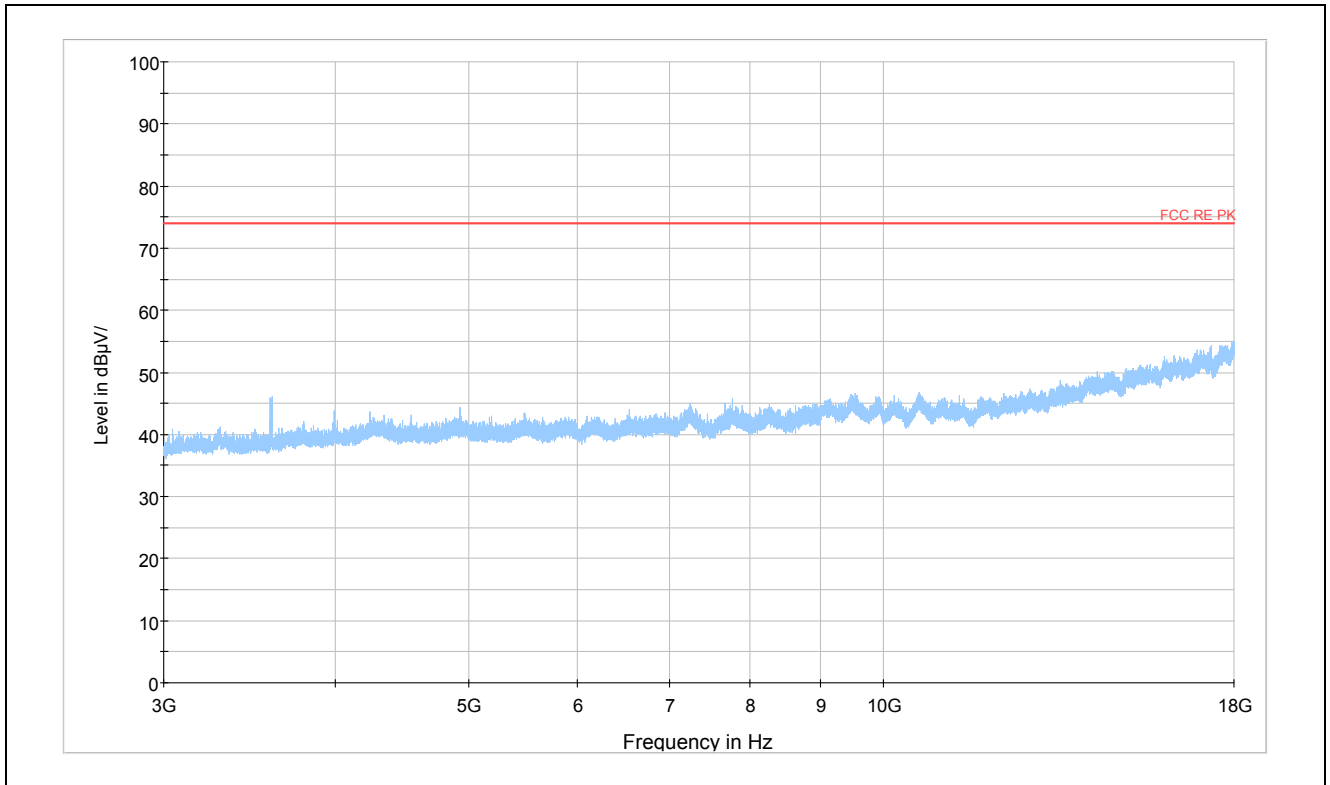

Radiates Emission from 3GHz to 18GHz

Average

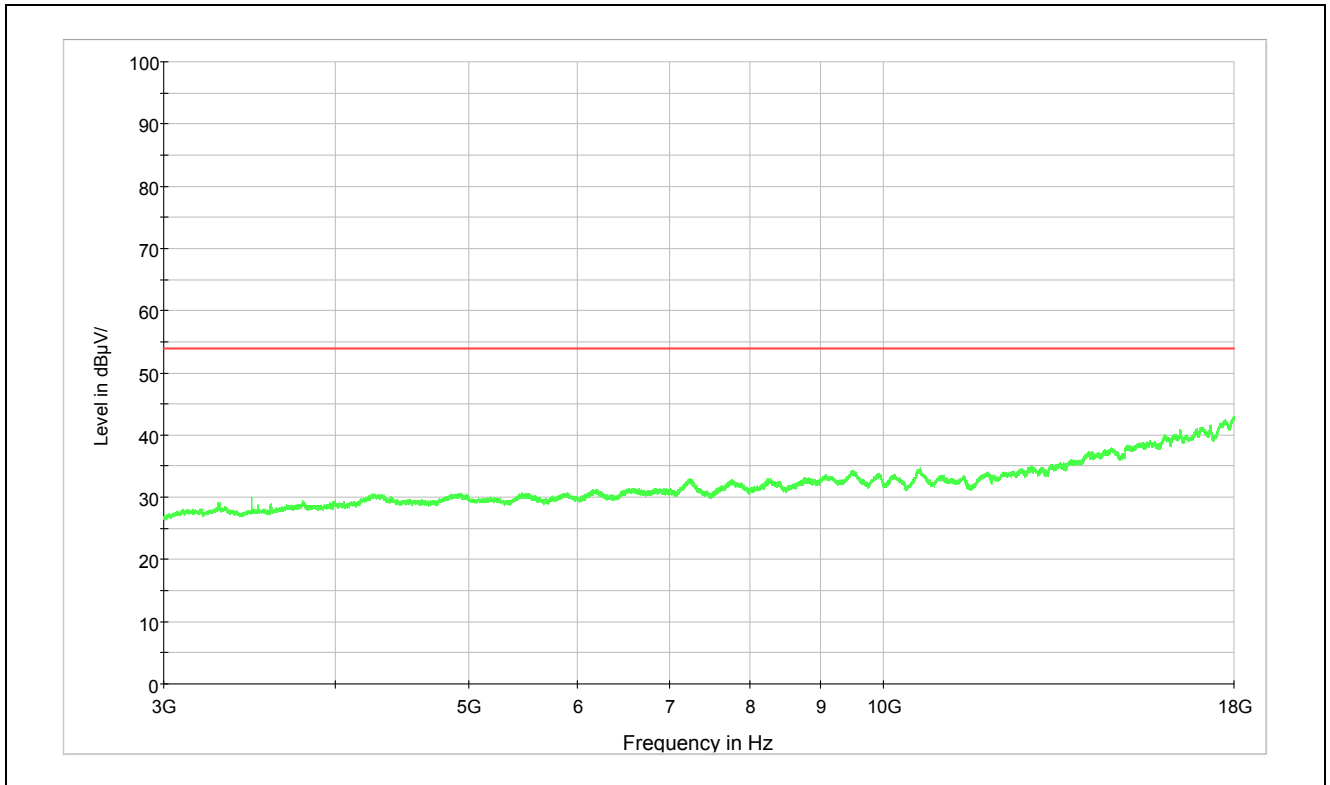

Radiates Emission from 3GHz to 18GHz

Peak

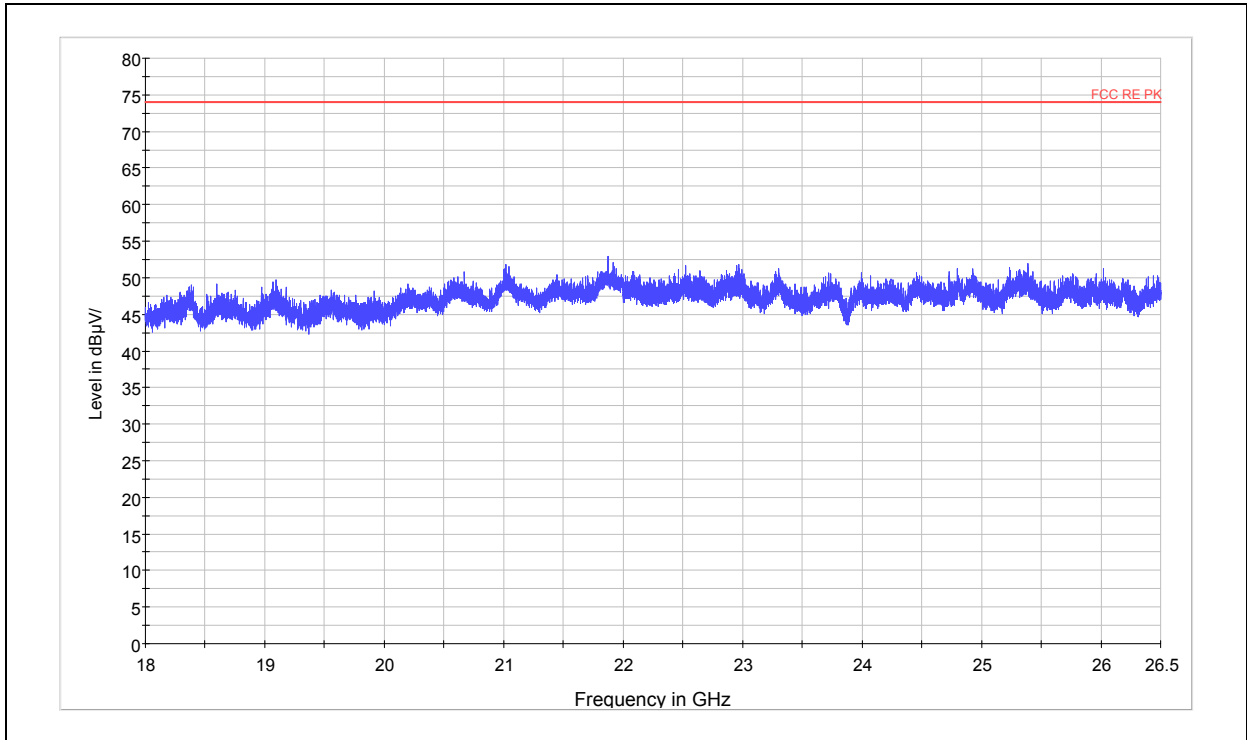

Radiates Emission from 18GHz to 26.5GHz

Average

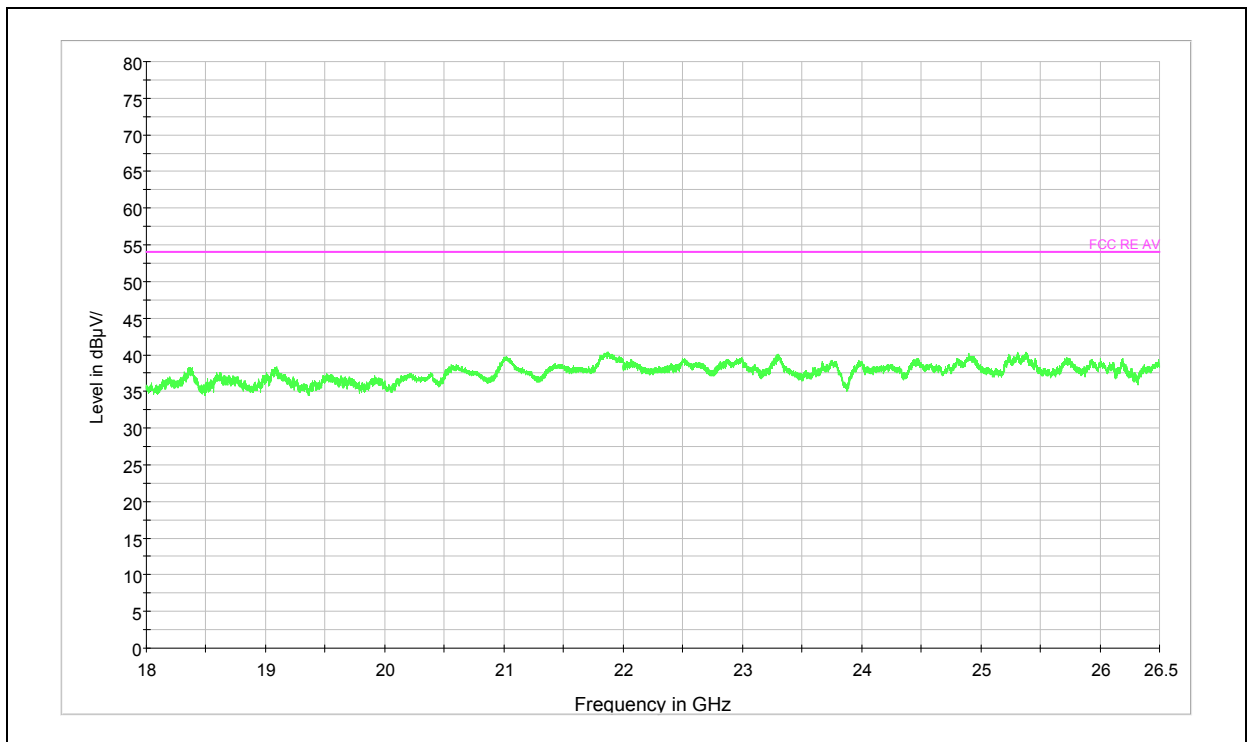

Radiates Emission from 18GHz to 26.5GHz

Channel 39

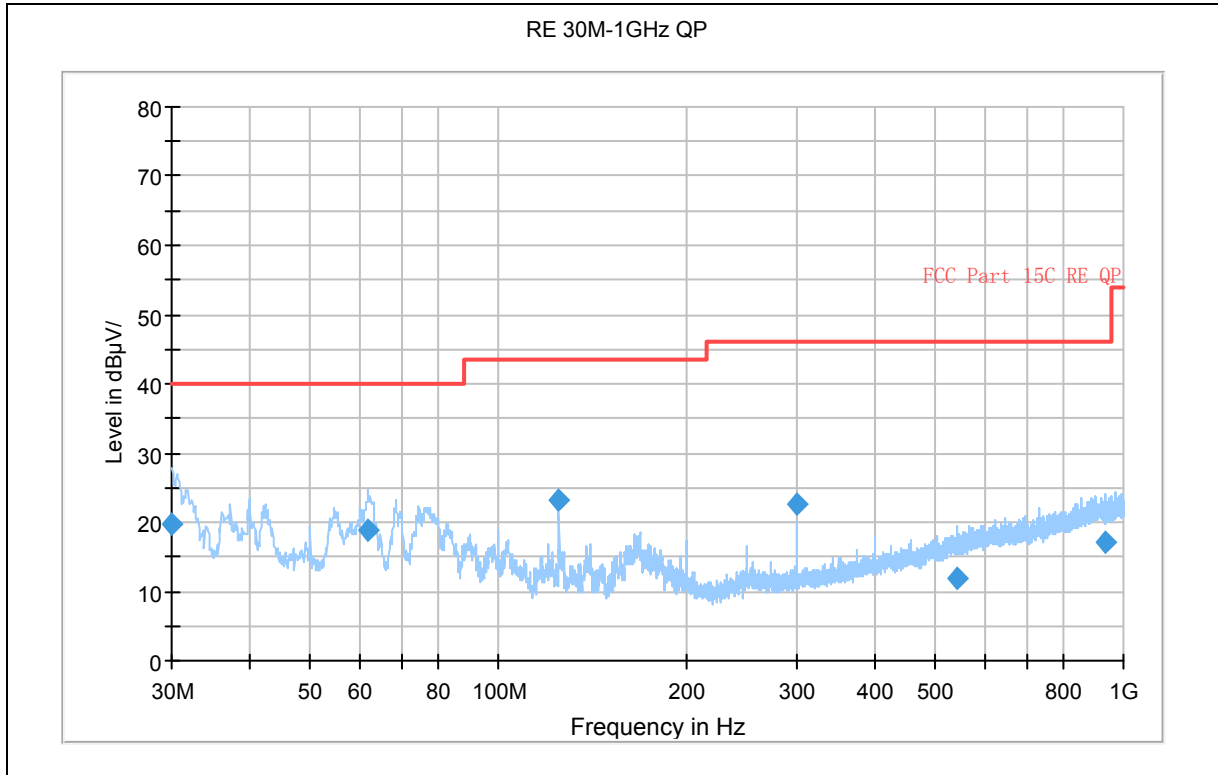

Radiates Emission from 30MHz to 1GHz

Frequency (MHz)	Quasi-Peak (dBuV/m)	Height (cm)	Polarization	Azimuth (deg)	Correct Factor (dB)	Margin (dB)	Limit (dBuV/m)
30.000000	19.7	100.0	Vertical	68.0	-23.9	20.3	40.0
61.768750	18.8	100.0	Vertical	164.0	-27.9	21.2	40.0
125.018750	23.1	175.0	Horizontal	202.0	-31.6	20.5	43.5
300.023750	22.5	100.0	Horizontal	68.0	-27.5	23.5	46.0
542.681250	12.0	100.0	Vertical	158.0	-22.1	34.0	46.0
934.238750	17.0	125.0	Vertical	0.0	-17.1	29.0	46.0

Note: All emissions level measured above 1GHz was more than 10dB below the limit

Peak

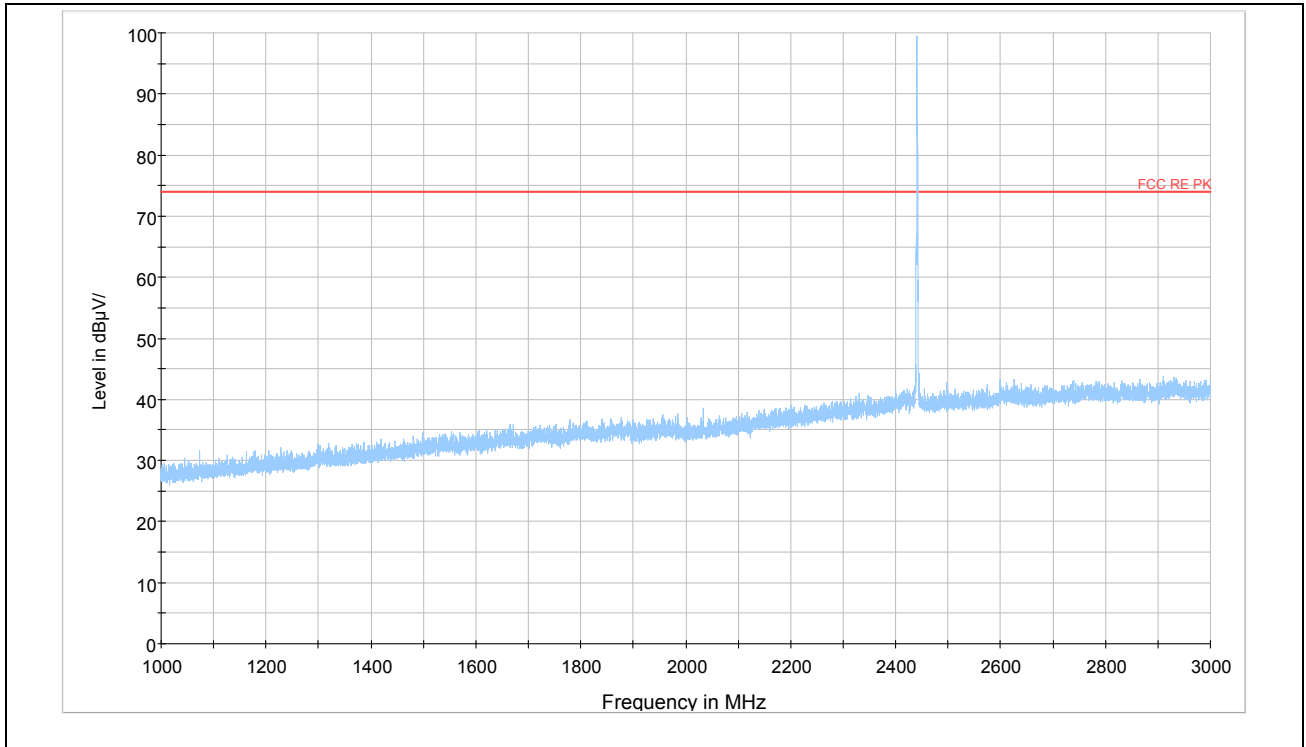

Note: The signal beyond the limit is carrier.
Radiates Emission from 1GHz to 3GHz

Average

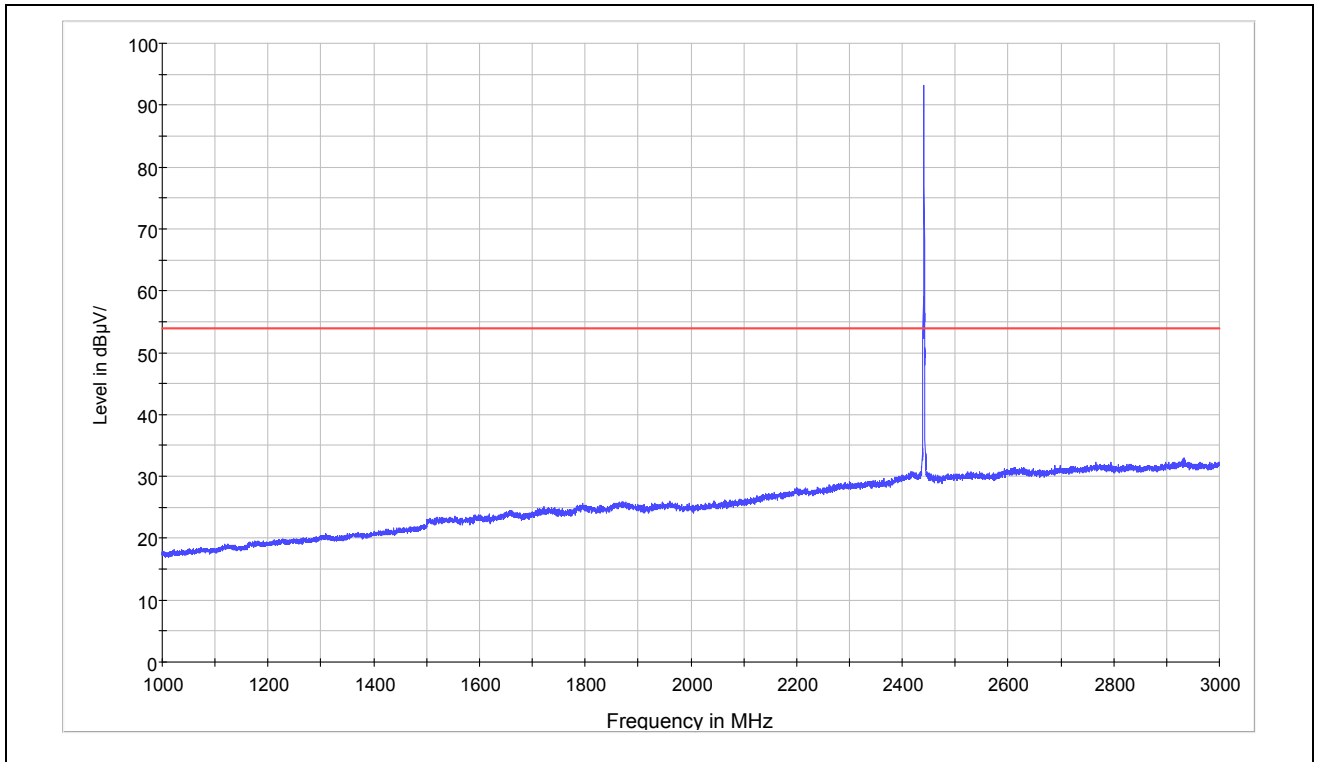

Note: The signal beyond the limit is carrier.
Radiates Emission from 1GHz to 3GHz

Peak

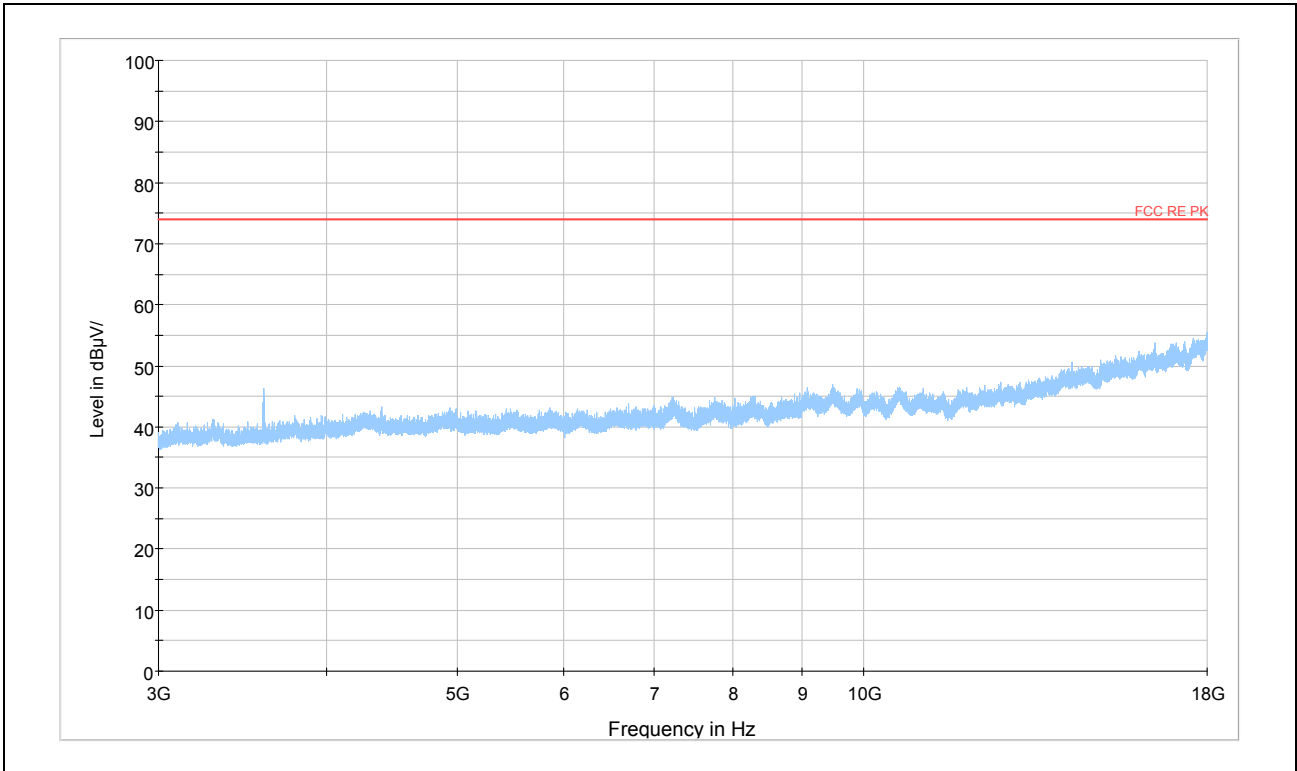

Radiates Emission from 3GHz to 18GHz

Average

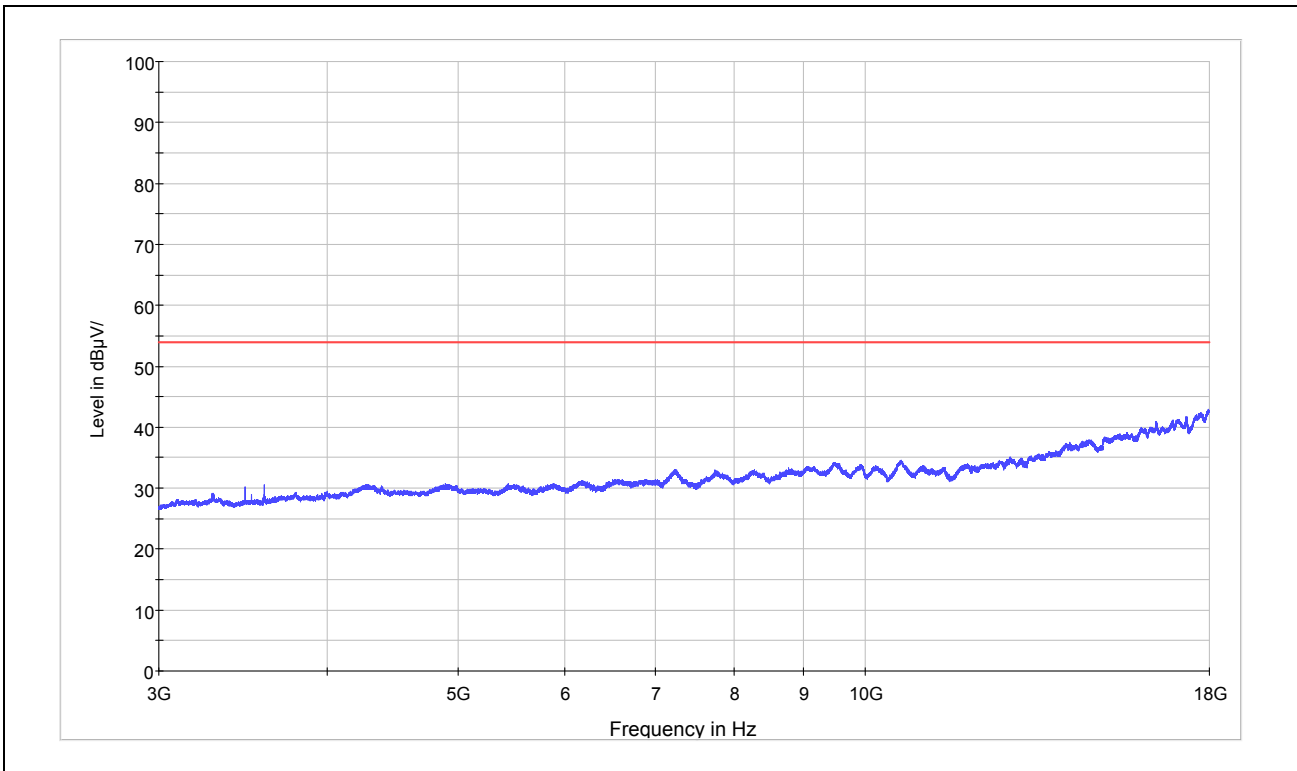

Radiates Emission from 3GHz to 18GHz

Peak

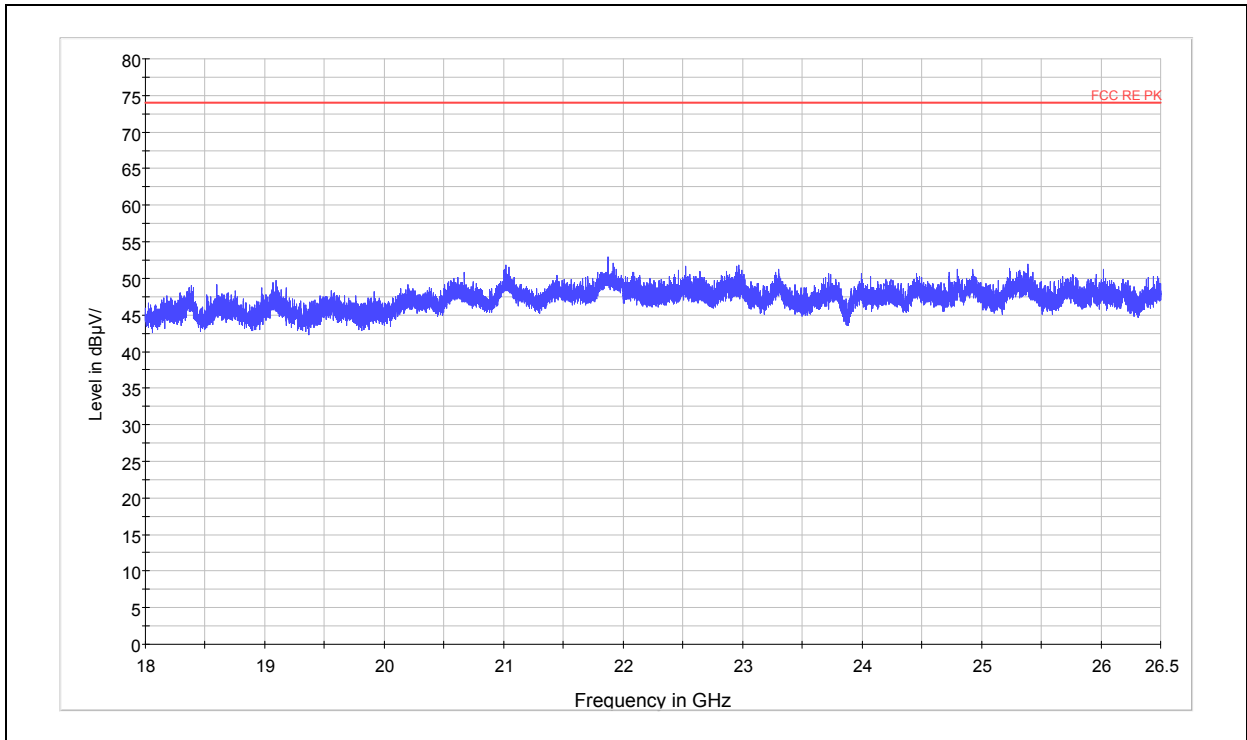

Radiates Emission from 18GHz to 26.5GHz

Average

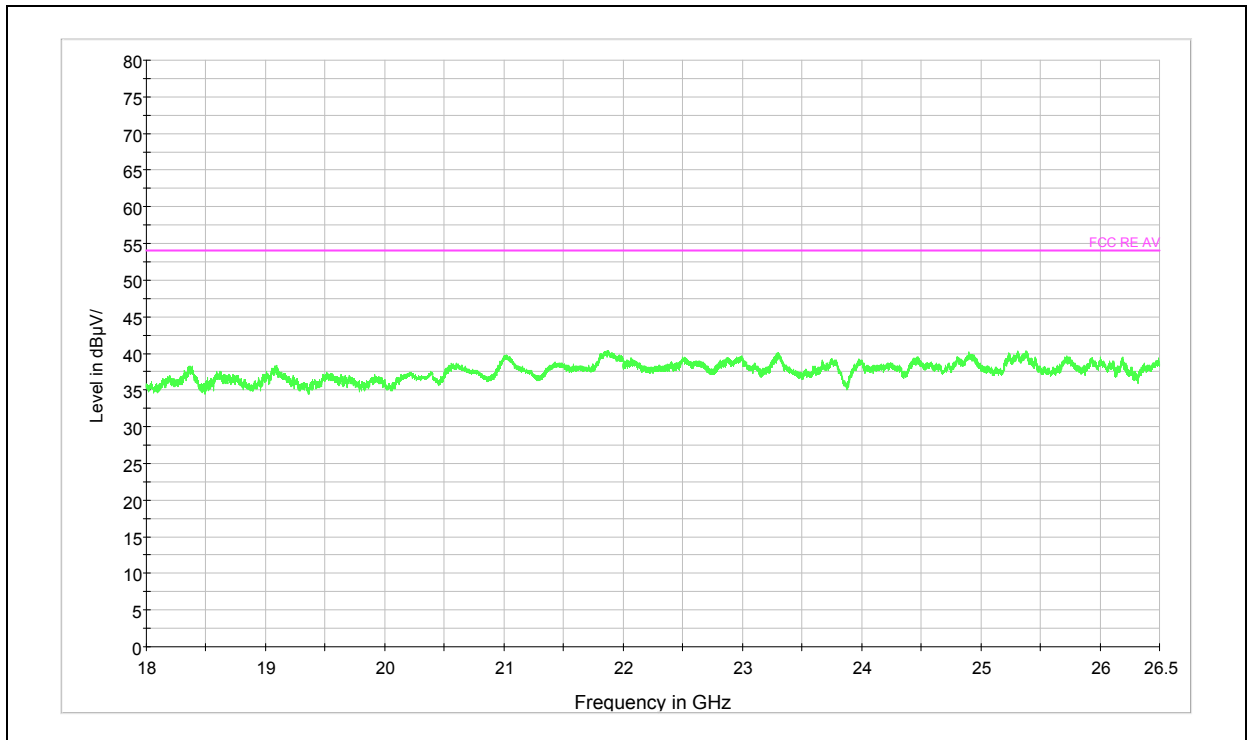

Radiates Emission from 18GHz to 26.5GHz

Channel 78

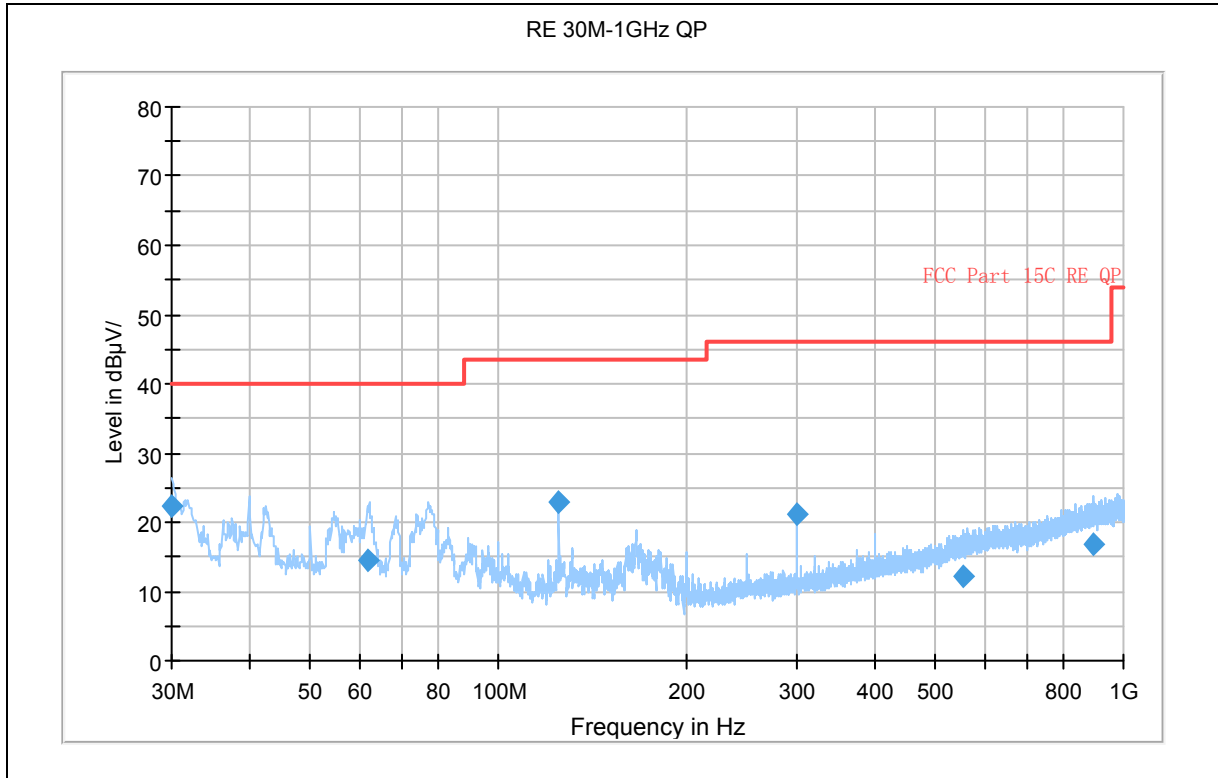

Radiates Emission from 30MHz to 1GHz

Frequency (MHz)	Quasi-Peak (dBuV/m)	Height (cm)	Polarization	Azimuth (deg)	Correct Factor (dB)	Margin (dB)	Limit (dBuV/m)
30.000000	22.2	100.0	Vertical	68.0	-23.9	17.8	40.0
61.731250	14.6	116.0	Vertical	165.0	-27.9	25.4	40.0
125.018750	22.9	100.0	Vertical	3.0	-31.6	20.6	43.5
300.023750	21.1	100.0	Vertical	13.0	-27.5	24.9	46.0
555.495000	12.1	191.0	Vertical	270.0	-21.8	33.9	46.0
896.457500	16.9	225.0	Vertical	22.0	-17.2	29.1	46.0

Note: All emissions level measured above 1GHz was more than 10dB below the limit

Peak

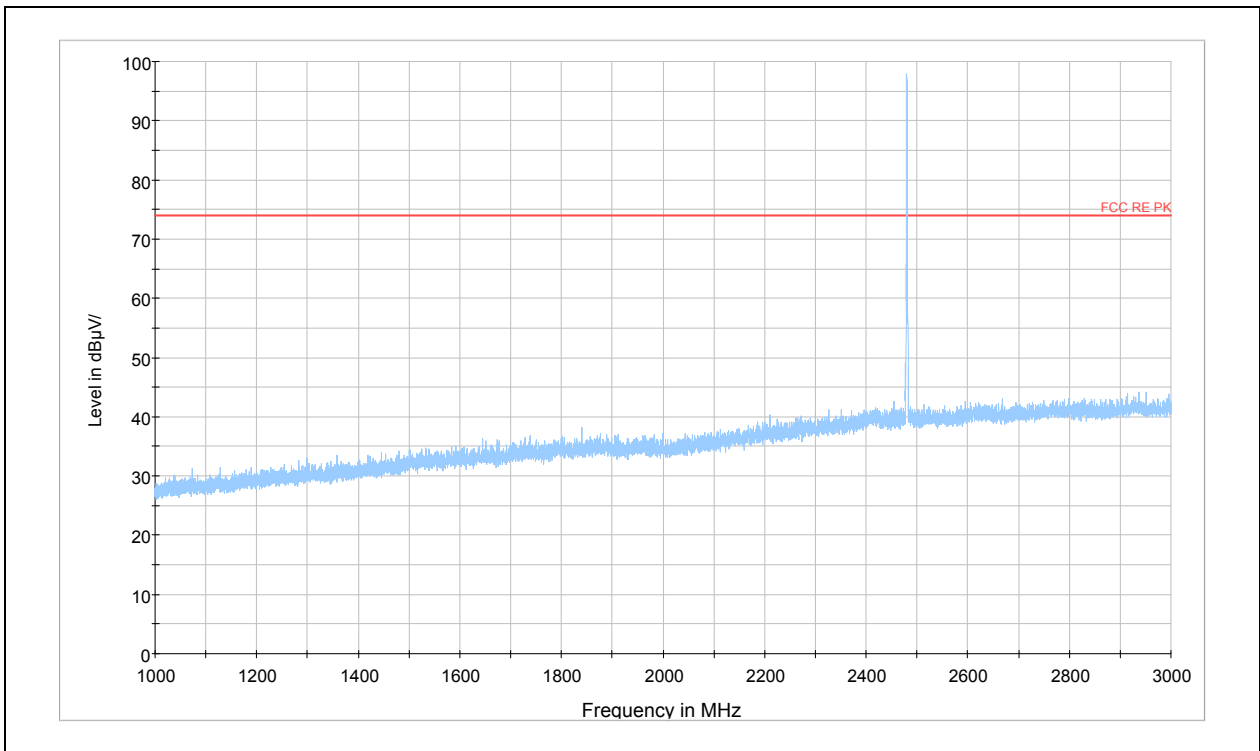

Note: The signal beyond the limit is carrier.
Radiates Emission from 1GHz to 3GHz

Average

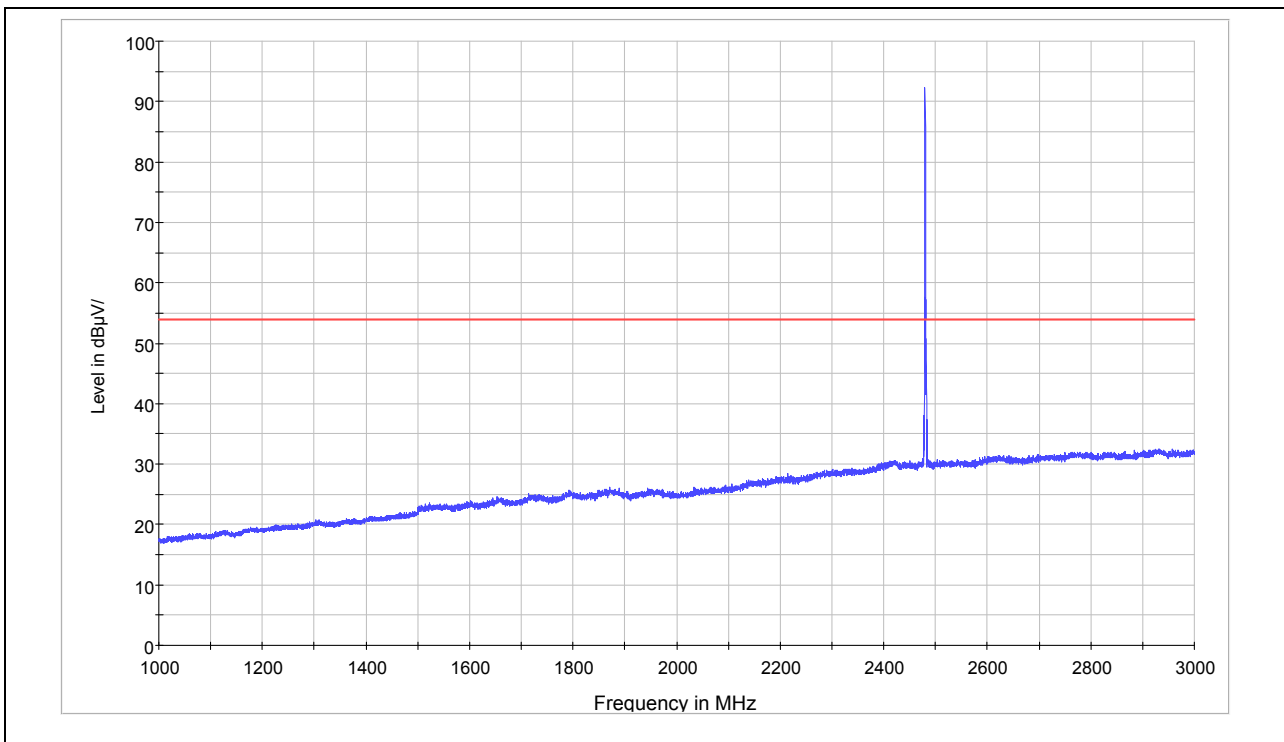

Note: The signal beyond the limit is carrier.
Radiates Emission from 1GHz to 3GHz

Peak

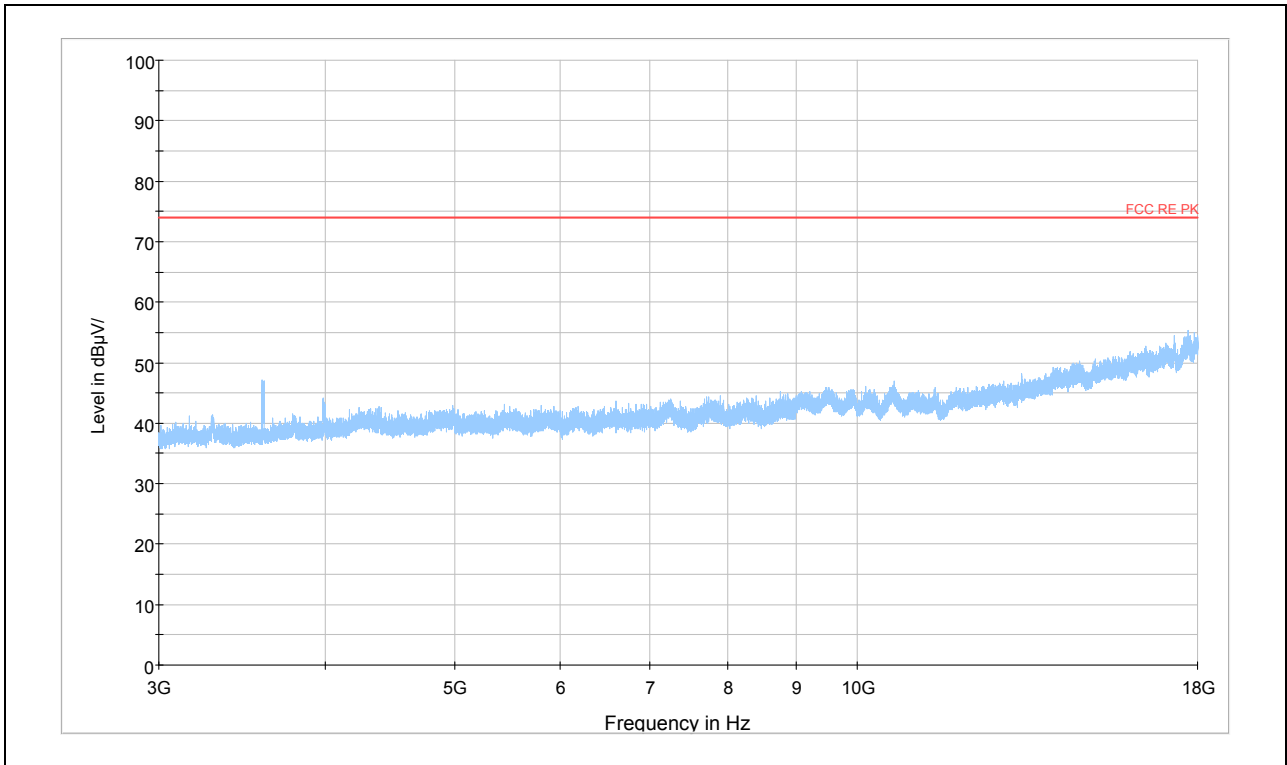

Radiates Emission from 3GHz to 18GHz

Average

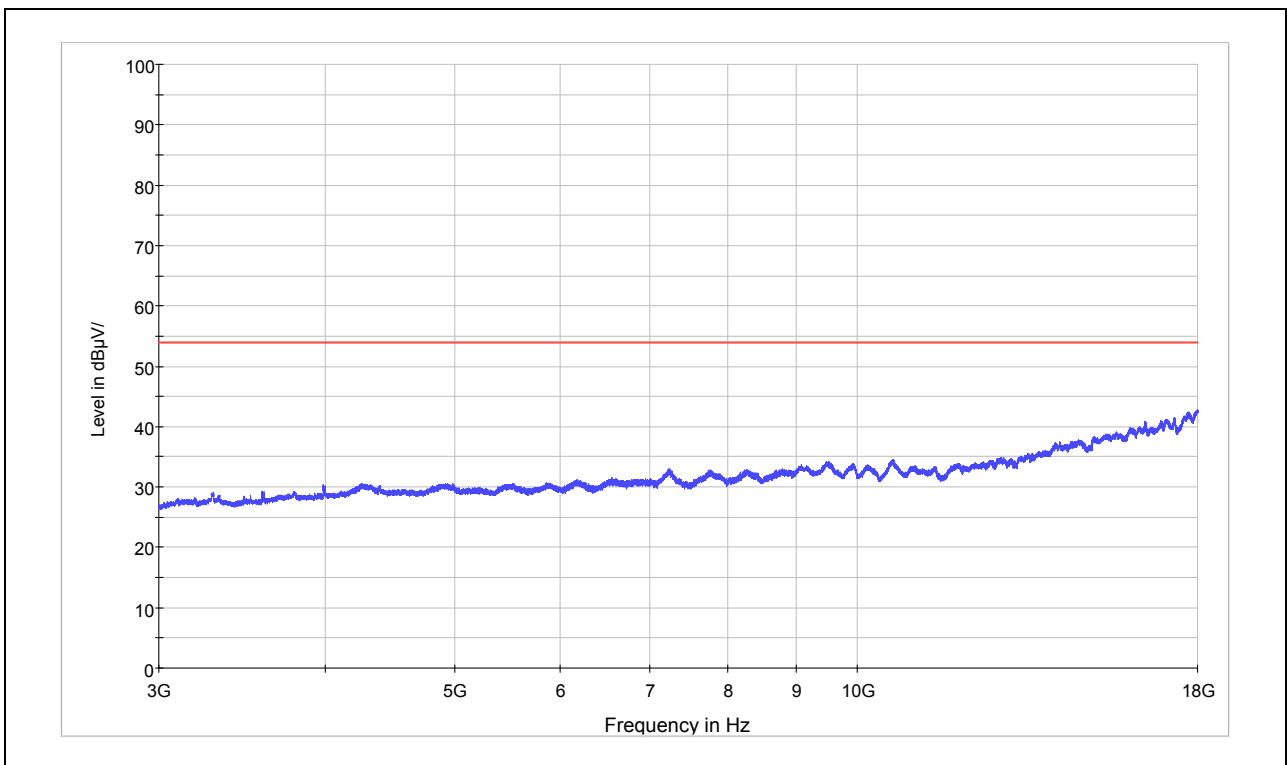

Radiates Emission from 3GHz to 18GHz

Peak

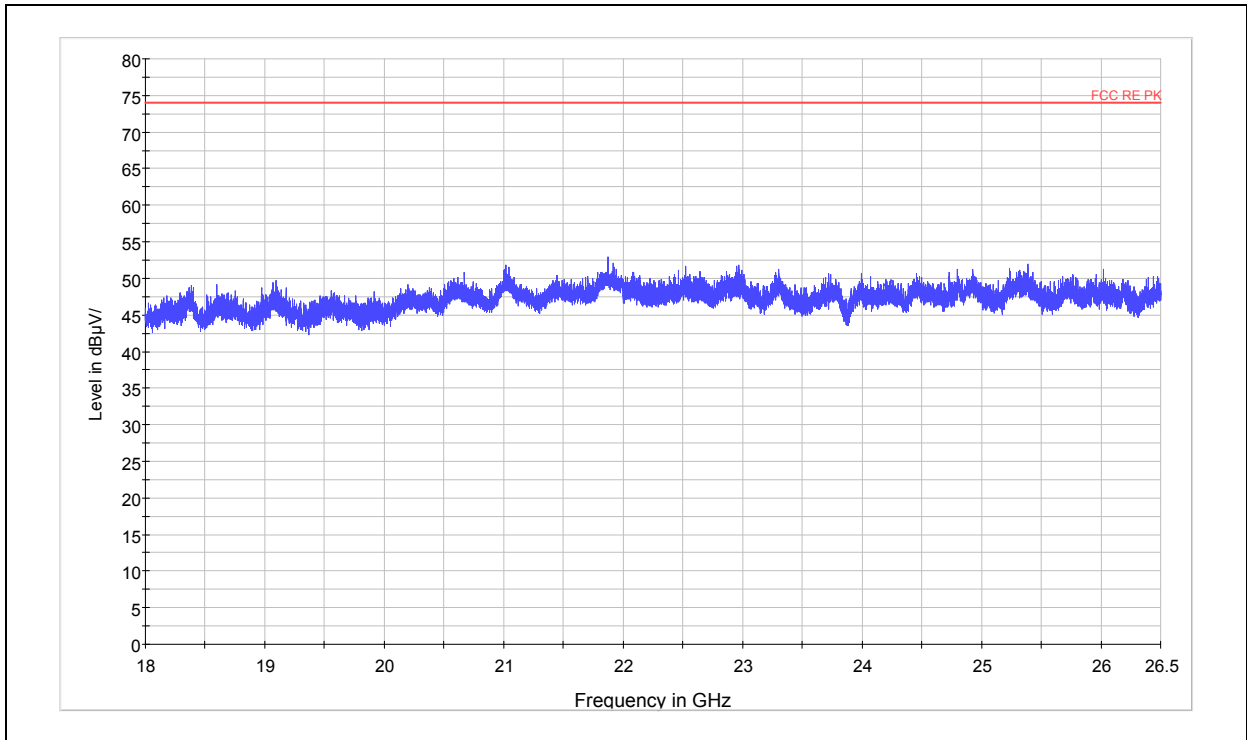

Radiates Emission from 18GHz to 26.5GHz

Average

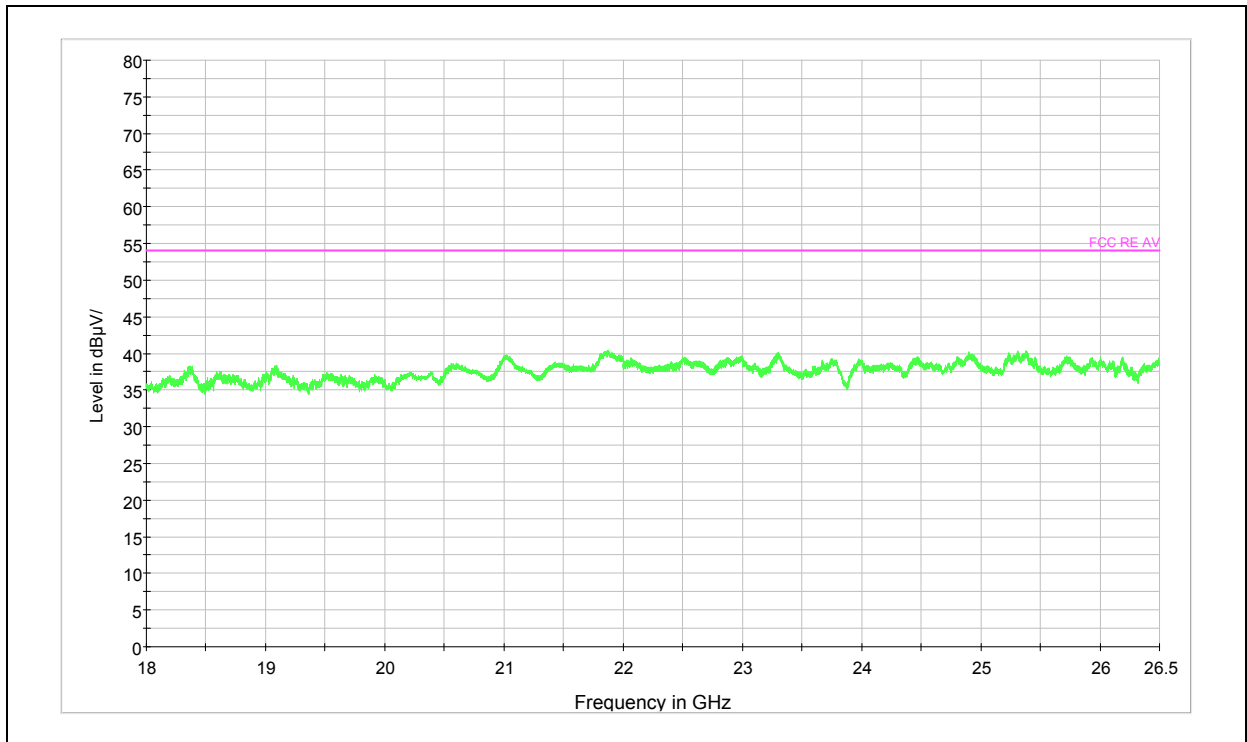

Radiates Emission from 18GHz to 26.5GHz

2.11. Conducted Emission

Ambient condition

Temperature	Relative humidity	Pressure
23°C ~25°C	45%~50%	101.5kPa

Methods of Measurement

The EUT is placed on a non-metallic table of 80cm height above the horizontal metal reference ground plane. During the test, the EUT was operating in its typical mode. The test method is according to ANSI C63.4-2003. Connect the AC power line of the EUT to the L.I.S.N. Use EMI receiver to detect the average and Quasi-peak value. RBW is set to 9kHz,VBW is set to 30kHz.The measurement result should include both L line and N line.

The test is in transmit mode.

Test Setup

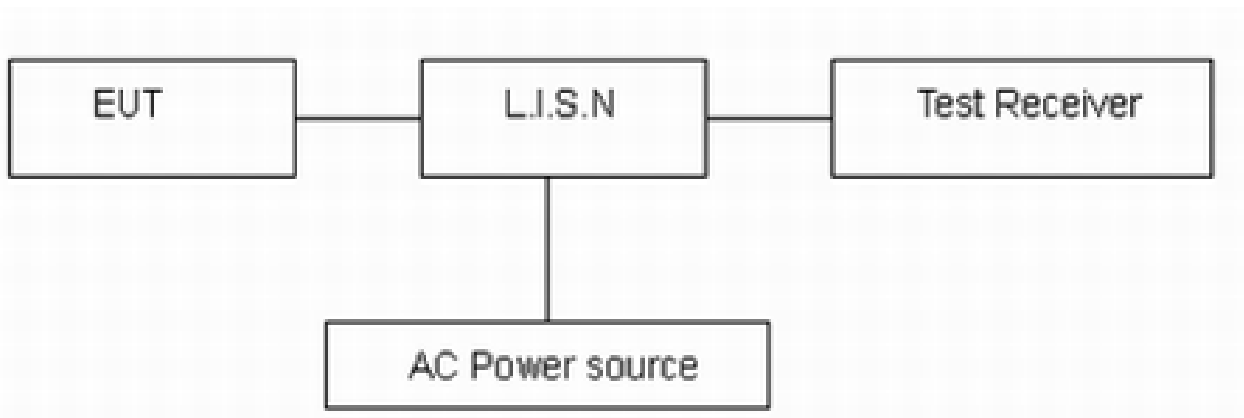

Note: AC Power source is used to change the voltage from 220V/50Hz to 110V/60Hz.

Limits

Frequency (MHz)	Conducted Limits(dBμV)	
	Quasi-peak	Average
0.15 - 0.5	66 to 56 *	56 to 46 *
0.5 - 5	56	46
5 - 30	60	50

*: Decreases with the logarithm of the frequency.

Measurement Uncertainty

The assessed measurement uncertainty to ensure 95% confidence level for the normal distribution is with the coverage factor $k = 1.96$. $U = 2.69$ dB.

Test Results:

CH0

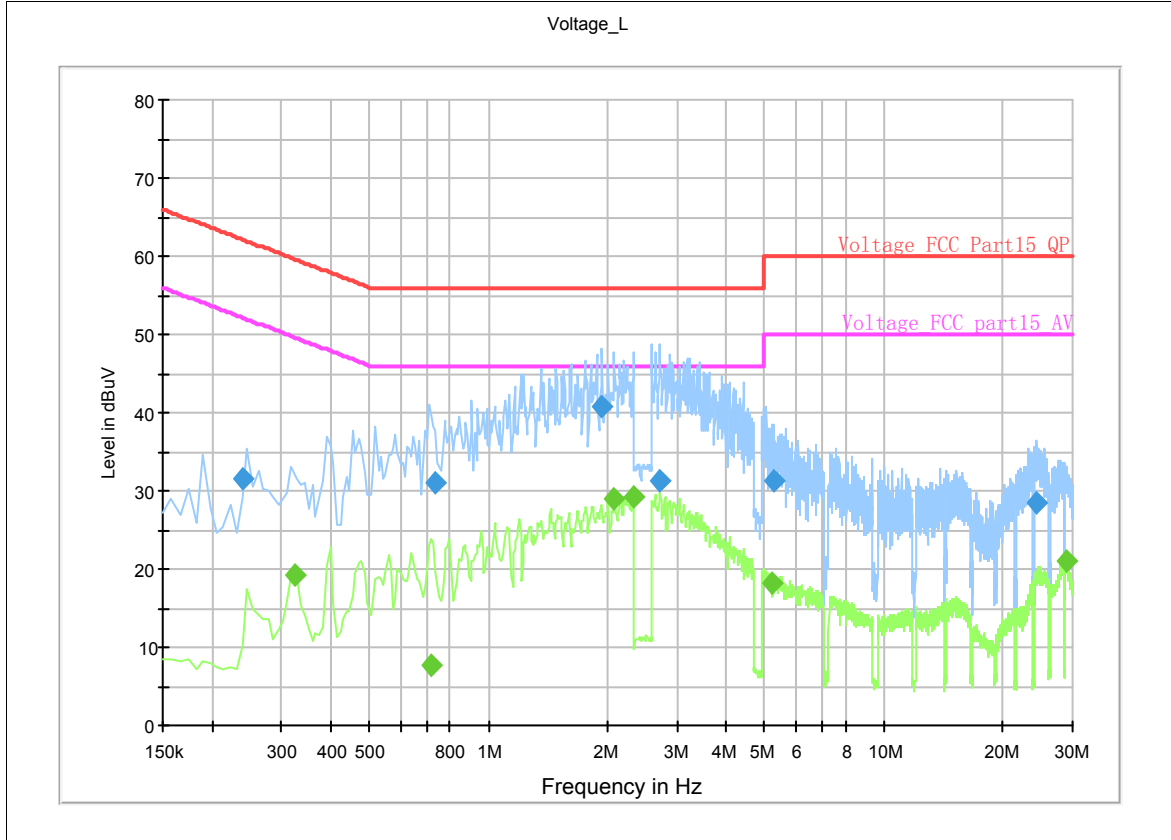

L Line

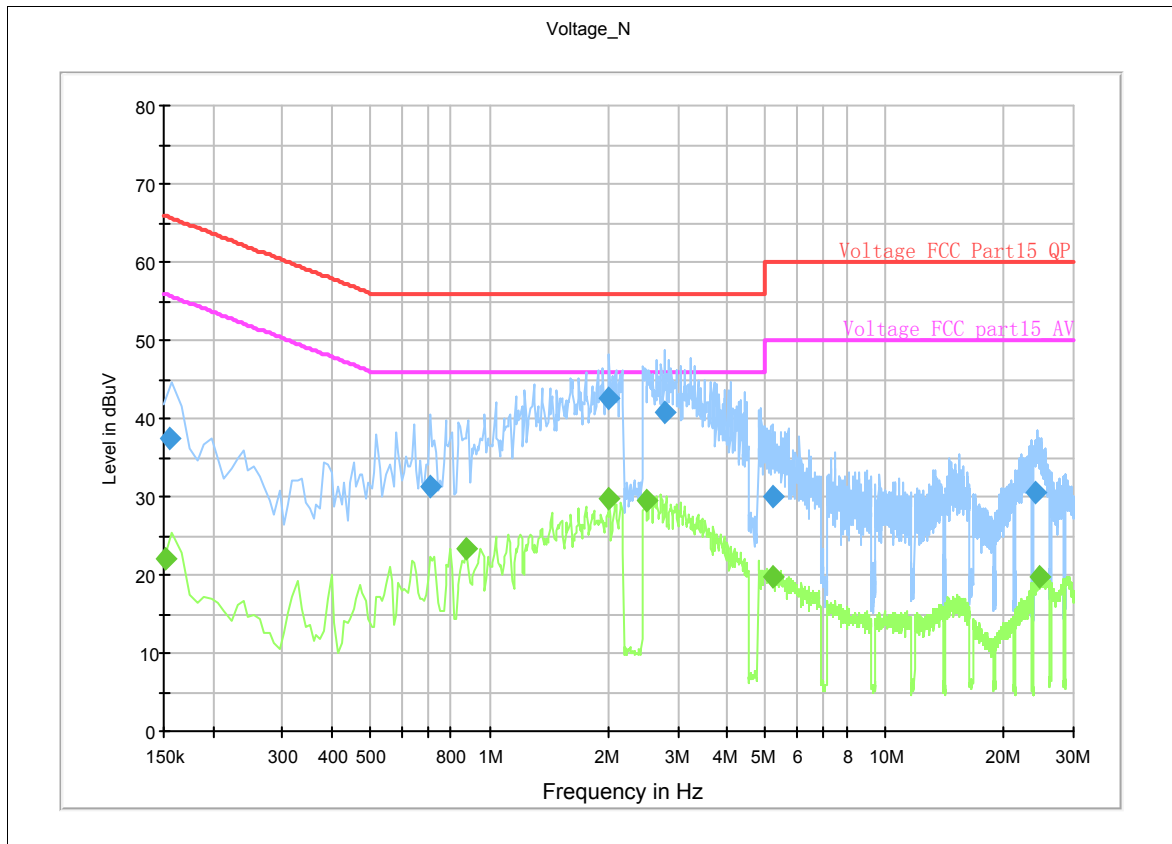

N Line

Conducted Emission from 150 KHz to 30 MHz

Frequency (MHz)	Detector	Line	Level (dBμV)	Limit (dBμV)	Margin (dB)	Factor (dB)
0.152	Average	N	21.9	55.9	34	10.1
0.871	Average	N	23.4	46	22.6	10.1
2.007	Average	N	29.7	46	16.3	10.1
2.077	Average	L	28.9	46	17.1	10.1
2.323	Average	L	29.1	46	16.9	10.1
2.485	Average	N	29.5	46	16.5	10.1
0.156	Quasi-peak	N	37.5	65.7	28.2	10.1
0.239	Quasi-peak	L	31.6	62.1	30.5	10.1
1.939	Quasi-peak	L	40.7	56	15.3	10.1
2.007	Quasi-peak	N	42.6	56	13.4	10.1
2.721	Quasi-peak	L	31.4	56	24.6	10.1
2.783	Quasi-peak	N	40.7	56	15.3	10.1

CH39

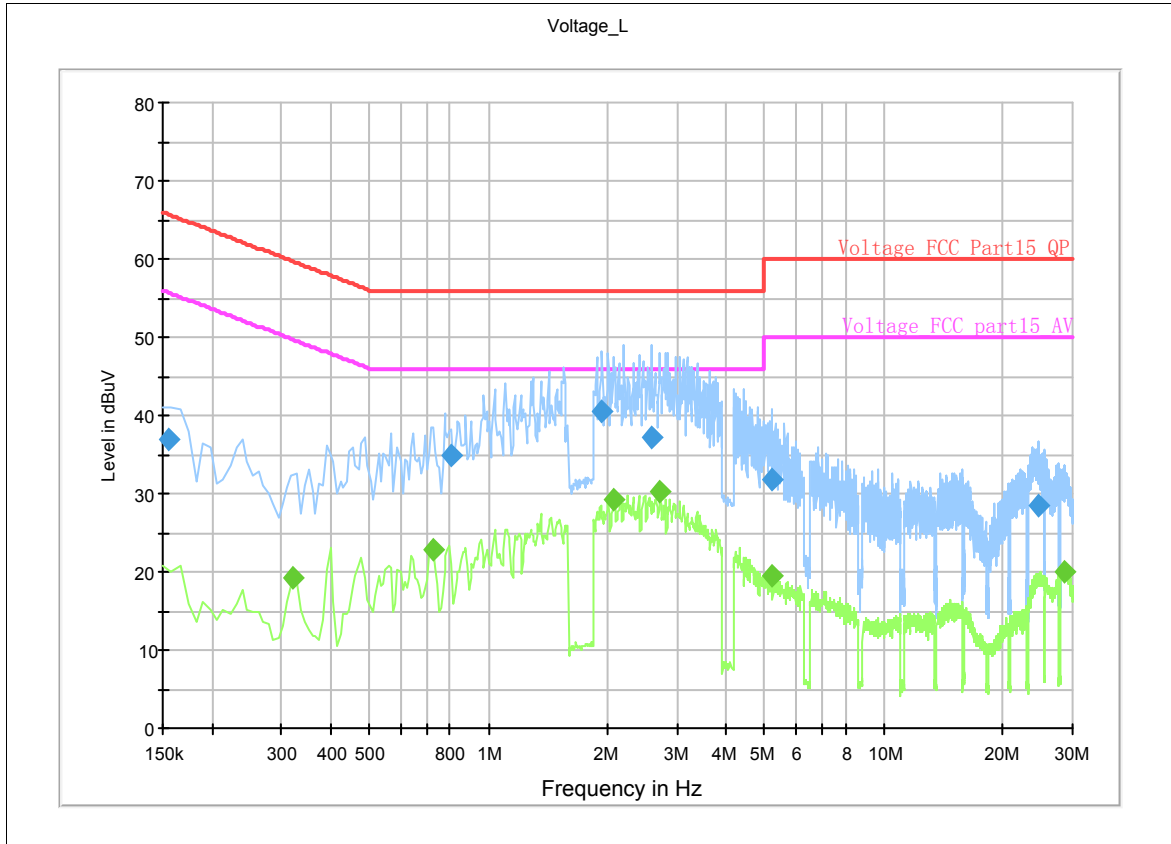

L Line

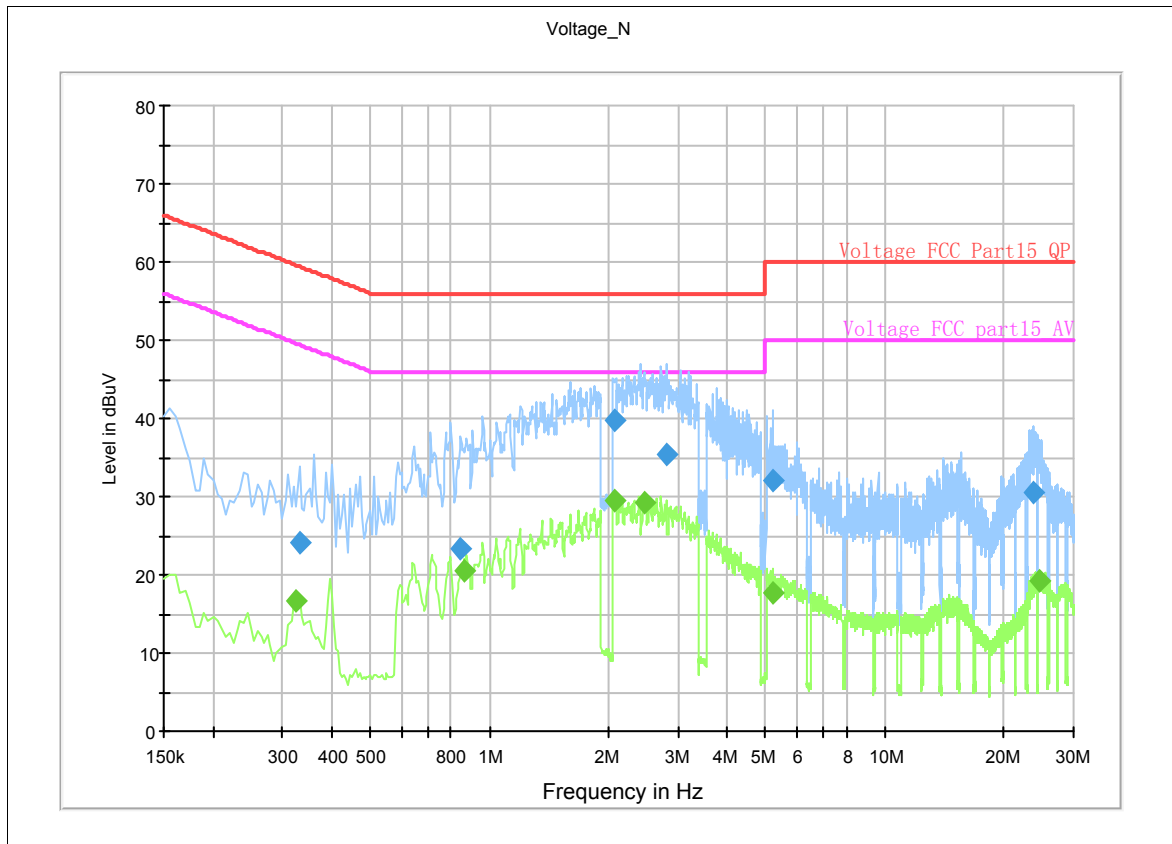

N Line

Conducted Emission from 150 KHz to 30 MHz

Frequency (MHz)	Detector	Line	Level (dBμV)	Limit (dBμV)	Margin (dB)	Factor (dB)
0.721	Average	L	22.9	46	23.1	10
0.86	Average	N	20.5	46	25.5	10.1
2.075	Average	N	29.6	46	16.4	10.1
2.079	Average	L	29.3	46	16.7	10.1
2.475	Average	N	29.3	46	16.7	10.1
2.717	Average	L	30.2	46	15.8	10.1
0.156	Quasi-peak	L	37	65.7	28.7	10.1
0.801	Quasi-peak	L	34.9	56	21.1	10.1
1.937	Quasi-peak	L	40.6	56	15.4	10.1
2.08	Quasi-peak	N	39.7	56	16.3	10.1
2.589	Quasi-peak	L	37.2	56	18.8	10.1
2.8	Quasi-peak	N	35.3	56	20.7	10.1

CH78

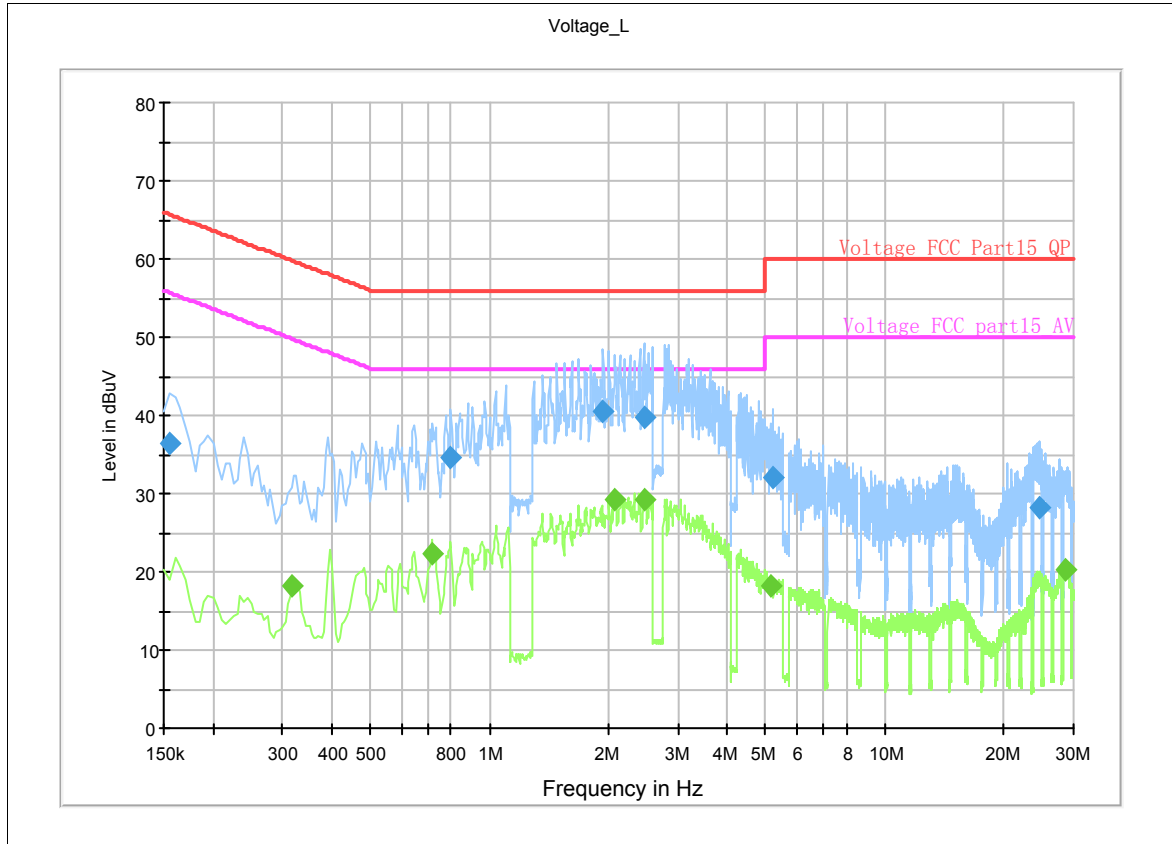

L Line

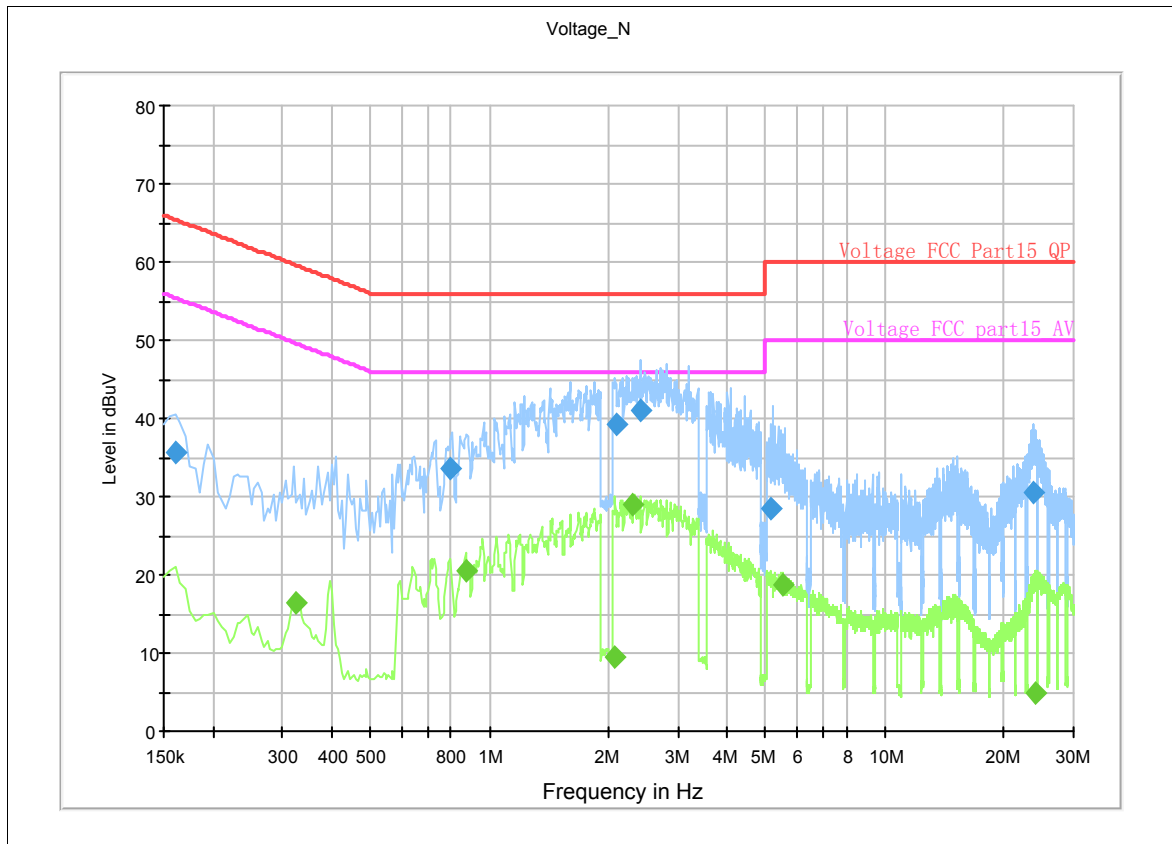

N Line

Conducted Emission from 150 KHz to 30 MHz

Frequency (MHz)	Detector	Line	Level (dB μ V)	Limit (dB μ V)	Margin (dB)	Factor (dB)
0.72	Average	L	22.4	46	23.6	10
0.875	Average	N	20.5	46	25.5	10.1
2.08	Average	L	29.2	46	16.8	10.1
2.315	Average	N	28.9	46	17.1	10.1
2.475	Average	L	29.3	46	16.7	10.1
28.78	Average	L	20.2	50	29.8	10.5
0.155	Quasi-peak	L	36.4	65.7	29.3	10.1
0.16	Quasi-peak	N	35.7	65.5	29.8	10.1
1.935	Quasi-peak	L	40.5	56	15.5	10.1
2.085	Quasi-peak	N	39.2	56	16.8	10.1
2.4	Quasi-peak	N	41.1	56	14.9	10.1
2.475	Quasi-peak	L	39.7	56	16.3	10.1

3. Main Test Instruments

No.	Name	Type	Manufacturer	Serial Number	Calibration Date	Valid Period
01	BT Base Station Simulator	CBT	R&S	100271	2009-11-26	One year
02	Signal Analyzer	FSV	R&S	100815	2010-06-28	One year
03	Signal generator	SMR27	R&S	100365	2010-07-01	One year
04	Spectrum Analyzer	E4445A	Agilent	MY46181146	2010-06-07	One year
05	EMI Test Receiver	ESCI	R&S	100948	2010-07-01	One year
06	Trilog Antenna	VULB 9163	SCHWARZBECK	9163-201	2010-06-29	Two years
07	Horn Antenna	HF907	R&S	100126	2009-07-02	Two years
08	AC Power Source	AFC-11005G	APC	F309040118	2009-08-03	Three years
09	Power Splitter	11667A	Agilent	52960	NA	NA
10	Semi-Anechoic Chamber	9.6*6.7*6.6m	ETS-Lindgren	NA	NA	NA
11	EMI test software	ES-K1	R&S	NA	NA	NA

*****END OF REPORT BODY*****

TA Technology (Shanghai) Co., Ltd.
Test Report

Registration Num:428261

Report No.: RZA2010-1332RF15C-R1

Page 60 of 62

ANNEX A: EUT Appearance and Test Setup

A.1 EUT Appearance



a EUT



b Battery

TA Technology (Shanghai) Co., Ltd.
Test Report

Registration Num:428261

Report No.: RZA2010-1332RF15C-R1

Page 61 of 62



c Charger

Picture 1 EUT and Auxiliary

A.2 Test Setup



Picture 2 Radiated Emission Test Setup

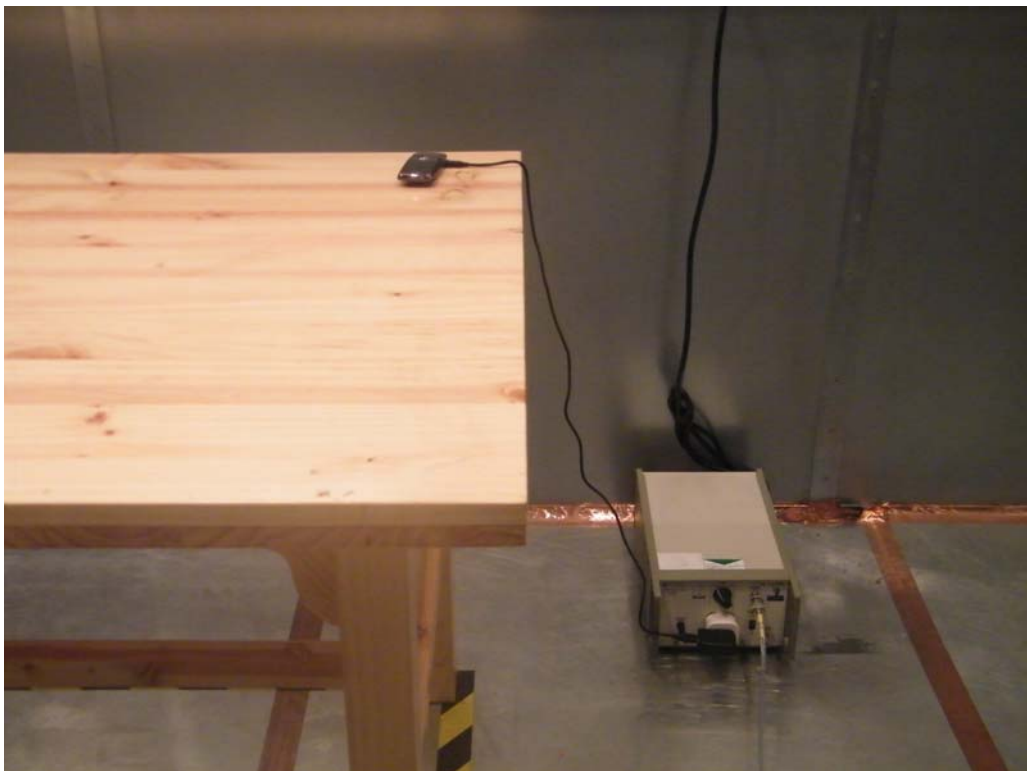

Picture 3 Conducted Emission Test Setup