



# FCC RF Test Report

**APPLICANT** : Lenovo Mobile Communication Technology Ltd.  
**EQUIPMENT** : Lenovo Mobile Phone  
**BRAND NAME** : lenovo  
**MODEL NAME** : Lenovo S90-L  
**FCC ID** : YCNS90L  
**MID** : 90L00111  
**STANDARD** : FCC Part 15 Subpart C §15.247  
**CLASSIFICATION** : (DTS) Digital Transmission System

The product was received on Nov. 05, 2014 and testing was completed on Nov. 20, 2014. We, SPORTON INTERNATIONAL (KUNSHAN) INC., would like to declare that the tested sample has been evaluated in accordance with the test procedures and has been in compliance with the applicable technical standards.

The test results in this report apply exclusively to the tested model / sample. Without written approval of SPORTON INTERNATIONAL (KUNSHAN) INC., the test report shall not be reproduced except in full.

Reviewed by: Joseph Lin / Supervisor

Approved by: Jones Tsai / Manager



**SPORTON INTERNATIONAL (KUNSHAN) INC.**

**No. 3-2, PingXiang Road, Kunshan, Jiangsu Province, P. R. China**



## TABLE OF CONTENTS

**REVISION HISTORY..... 3**

**SUMMARY OF TEST RESULT ..... 4**

**1 GENERAL DESCRIPTION ..... 5**

    1.1 Applicant ..... 5

    1.2 Manufacturer ..... 5

    1.3 Product Feature of Equipment Under Test ..... 5

    1.4 Product Specification subjective to this standard ..... 5

    1.5 Modification of EUT ..... 6

    1.6 Testing Location ..... 6

    1.7 Applicable Standards ..... 6

**2 TEST CONFIGURATION OF EQUIPMENT UNDER TEST ..... 7**

    2.1 Carrier Frequency Channel ..... 7

    2.2 Pre-Scanned RF Power ..... 8

    2.3 Test Mode ..... 9

    2.4 Connection Diagram of Test System ..... 10

    2.5 Support Unit used in test configuration and system ..... 11

    2.6 EUT Operation Test Setup ..... 11

    2.7 Measurement Results Explanation Example ..... 11

**3 TEST RESULT ..... 12**

    3.1 6dB Bandwidth Measurement ..... 12

    3.2 Output Power Measurement ..... 15

    3.3 Power Spectral Density Measurement ..... 18

    3.4 Conducted Band Edges and Spurious Emission Measurement ..... 21

    3.5 Radiated Band Edges and Spurious Emission Measurement ..... 31

    3.6 AC Conducted Emission Measurement ..... 48

    3.7 Antenna Requirements ..... 52

**4 LIST OF MEASURING EQUIPMENT ..... 53**

**5 UNCERTAINTY OF EVALUATION ..... 54**

**APPENDIX A. SETUP PHOTOGRAPHS**



### REVISION HISTORY

REPORT NO.	VERSION	DESCRIPTION	ISSUED DATE
FR4N0501C	Rev. 01	Initial issue of report	Nov. 26, 2014



### SUMMARY OF TEST RESULT

Report Section	FCC Rule	Description	Limit	Result	Remark
3.1	15.247(a)(2)	6dB Bandwidth	$\geq 0.5\text{MHz}$	Pass	-
3.2	15.247(b)	Power Output Measurement	$\leq 30\text{dBm}$	Pass	-
3.3	15.247(e)	Power Spectral Density	$\leq 8\text{dBm}/3\text{kHz}$	Pass	-
3.4	15.247(d)	Conducted Band Edges	$\leq 20\text{dBc}$	Pass	-
		Conducted Spurious Emission		Pass	-
3.5	15.247(d)	Radiated Band Edges and Radiated Spurious Emission	15.209(a) & 15.247(d)	Pass	Under limit 6.96 dB at 36.790 MHz
3.6	15.207	AC Conducted Emission	15.207(a)	Pass	Under limit 14.66 dB at 4.570 MHz
3.7	15.203 & 15.247(b)	Antenna Requirement	N/A	Pass	-



# 1 General Description

## 1.1 Applicant

**Lenovo Mobile Communication Technology Ltd.**

No.999, Qishan North 2nd Road, Information & Optoelectronics Park, Torch Hi-tech Industry Development Zone, Xiamen, P.R.China

## 1.2 Manufacturer

**Lenovo PC HK Limited**

23/F, Lincoln House, Taikoo Place 979 King's Road, Quarry Bay, Hong Kong

## 1.3 Product Feature of Equipment Under Test

Product Feature	
Equipment	Lenovo Mobile Phone
Brand Name	lenovo
Model Name	Lenovo S90-L
FCC ID	YCNS90L
MID	90L00111
EUT supports Radios application	GSM/GPRS/EGPRS/WCDMA/HSPA/LTE WLAN 2.4GHz 802.11b/g/n HT20 Bluetooth v3.0 + EDR/Bluetooth v4.0 LE
HW Version	H-3-01
SW Version	S90-L_AMX_ROW_B007_141113
EUT Stage	Production Unit

**Remark:** The above EUT's information was declared by manufacturer. Please refer to the specifications or user's manual for more detailed description.

## 1.4 Product Specification subjective to this standard

Product Specification subjective to this standard	
Tx/Rx Channel Frequency Range	2412 MHz ~ 2462 MHz
Maximum (Peak) Output Power to Antenna	802.11b : 20.02 dBm (0.1005 W) 802.11g : 20.48 dBm (0.1117 W) 802.11n HT20 : 19.85 dBm (0.0966 W)
Antenna Type / Gain	PIFA Antenna with gain -4.6 dBi
Type of Modulation	802.11b : DSSS (DBPSK / DQPSK / CCK) 802.11g/n : OFDM (BPSK / QPSK / 16QAM / 64QAM)



### 1.5 Modification of EUT

No modifications are made to the EUT during all test items.

### 1.6 Testing Location

<b>Test Site</b>	SPORTON INTERNATIONAL (KUNSHAN) INC.			
<b>Test Site Location</b>	No. 3-2, PingXiang Road, Kunshan, Jiangsu Province, P. R. China TEL: +86-0512-5790-0158 FAX: +86-0512-5790-0958			
<b>Test Site No.</b>	<b>Sporton Site No.</b>			<b>FCC Registration No.</b>
	TH01-KS	03CH01-KS	CO01-KS	149928

### 1.7 Applicable Standards

According to the specifications of the manufacturer, the EUT must comply with the requirements of the following standards:

- FCC Part 15 Subpart C §15.247
- FCC KDB Publication No. 558074 D01 DTS Meas. Guidance v03r02
- ANSI C63.4-2003

**Remark:**

1. All test items were verified and recorded according to the standards and without any deviation during the test.
2. This EUT has also been tested and complied with the requirements of FCC Part 15, Subpart B, recorded in a separate test report.



## 2 Test Configuration of Equipment Under Test

The EUT has been associated with peripherals and configuration operated in a manner tended to maximize its emission characteristics in a typical application. Frequency range investigated: conducted emission (150 kHz to 30 MHz) and radiated emission (9 kHz to the 10th harmonic of the highest fundamental frequency or to 40 GHz, whichever is lower). For radiated measurement, pre-scanned in three orthogonal panels, X, Y, Z. The worst cases (X plane) were recorded in this report.

The final configuration from all the combinations and the worst-case data rates were investigated by measuring the maximum power across all the data rates and modulation modes under section 2.2.

Based on the worst configuration found above, the RF power setting is set individually to meet FCC compliance limit for the final conducted and radiated tests shown in section 2.3.

### 2.1 Carrier Frequency Channel

Frequency Band	Channel	Freq. (MHz)	Channel	Freq. (MHz)
2400-2483.5 MHz	1	2412	7	2442
	2	2417	8	2447
	3	2422	9	2452
	4	2427	10	2457
	5	2432	11	2462
	6	2437	-	-



## 2.2 Pre-Scanned RF Power

Preliminary tests were performed in different data rate and data rate associated with the highest power were chosen for full test shown in the following tables.

2.4GHz 802.11b RF Output Power (dBm)						
Power vs. Channel			Power vs. Data Rate			
Channel	Frequency (MHz)	Data Rate 1Mbps	Channel	2Mbps	5.5Mbps	11Mbps
CH 01	2412 MHz	18.80	CH 11	19.87	19.94	19.92
CH 06	2437 MHz	19.25				
CH 11	2462 MHz	20.02				

2.4GHz 802.11g RF Output Power (dBm)										
Power vs. Channel			Power vs. Data Rate							
Channel	Frequency (MHz)	Data Rate 6Mbps	Channel	9Mbps	12Mbps	18Mbps	24Mbps	36Mbps	48Mbps	54Mbps
CH 01	2412 MHz	19.67	CH 11	20.38	20.46	20.38	20.45	20.05	20.32	20.35
CH 06	2437 MHz	19.99								
CH 11	2462 MHz	20.48								

2.4GHz 802.11n HT20 RF Output Power (dBm)										
Power vs. Channel			Power vs. MCS Index							
Channel	Frequency (MHz)	MCS Index MCS0	Channel	MCS1	MCS2	MCS3	MCS4	MCS5	MCS6	MCS7
CH 01	2412 MHz	19.24	CH 11	19.75	19.82	19.72	19.73	19.68	19.81	19.78
CH 06	2437 MHz	19.52								
CH 11	2462 MHz	19.85								





## 2.3 Test Mode

Final results of test modes, data rates and test channels are shown as following table.

Test Cases				
	Test Items	Mode	Data Rate	Test Channel
Conducted TCs	6dB BW Power Spectral Density	802.11b	1 Mbps	1/6/11
		802.11g	6 Mbps	1/6/11
		802.11n HT20	MCS0	1/6/11
	Output Power	802.11b	1 Mbps	1/6/11
		802.11g	6 Mbps	1/6/11
		802.11n HT20	MCS0	1/6/11
	Conducted Band Edge	802.11b	1 Mbps	1/11
		802.11g	6 Mbps	1/11
		802.11n HT20	MCS0	1/11
	Conducted Spurious Emission	802.11b	1 Mbps	1/6/11
		802.11g	6 Mbps	1/6/11
		802.11n HT20	MCS0	1/6/11
Radiated TCs	Radiated Band Edge	802.11b	1 Mbps	1/11
		802.11g	6 Mbps	1/11
		802.11n HT20	MCS0	1/11
	Radiated Spurious Emission	802.11b	1 Mbps	1/6/11
		802.11g	6 Mbps	1/6/11
		802.11n HT20	MCS0	1/6/11
AC Conducted Emission	Mode 1 : GSM850 Idle + Bluetooth Link + WLAN Link + USB Cable (Charging from Adapter) + Earphone			
<b>Remark:</b> For radiated test cases, the tests were performed with adapter, earphone and USB cable.				

## 2.4 Connection Diagram of Test System

### <WLAN Tx Mode>

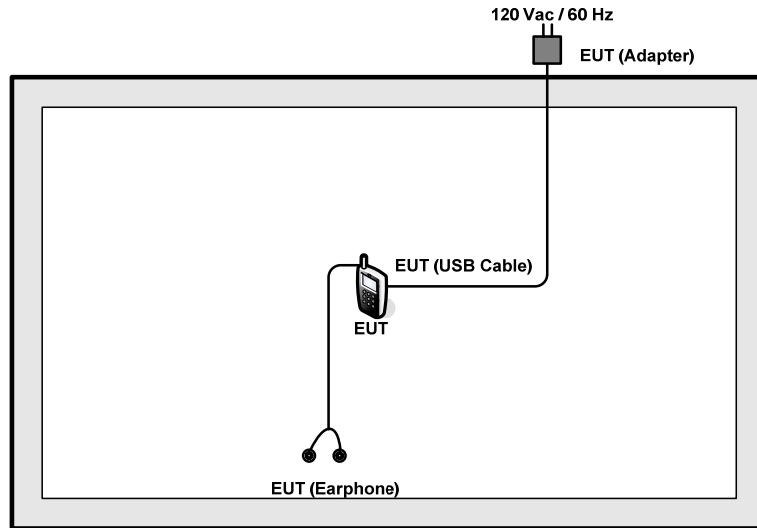

### <AC Conducted Emission Mode>

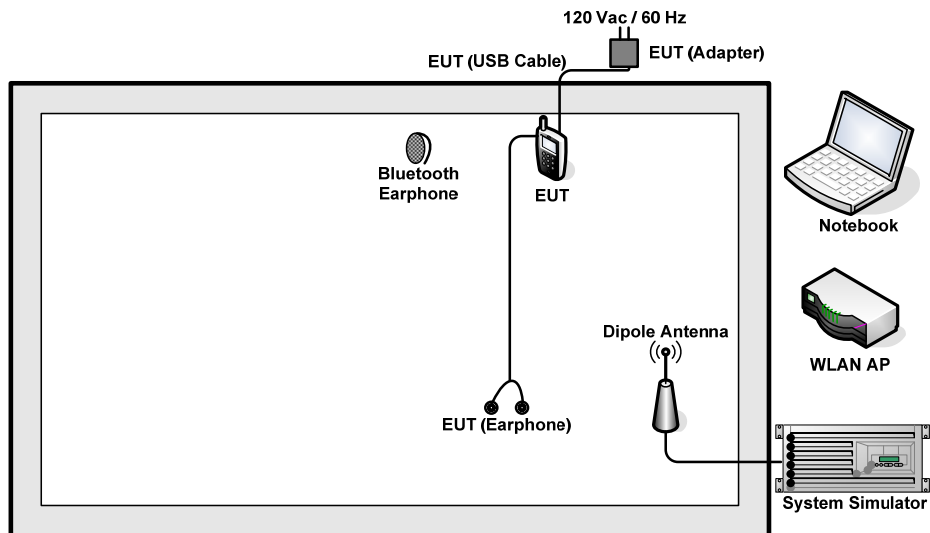

## 2.5 Support Unit used in test configuration and system

Item	Equipment	Trade Name	Model Name	FCC ID	Data Cable	Power Cord
1.	System Simulator	R&S	CMU 200	N/A	N/A	Unshielded, 1.8 m
2.	Notebook	Lenovo	G480	PRC4	N/A	shielded cable DC O/P 1.8 m unshielded AC I/P cable 1.8 m
3.	Bluetooth Earphone	Lenovo	LBH505	N/A	N/A	N/A
4.	WLAN AP	D-Link	DIR-855	KA2DIR855A2	N/A	Unshielded, 1.8m

## 2.6 EUT Operation Test Setup

For WLAN function, the engineering test program was provided and enabled to make EUT continuous transmit/receive.

For AC power line conducted emissions, the EUT was set to connect with the WLAN AP under large package sizes transmission.

## 2.7 Measurement Results Explanation Example

**For all conducted test items:**

The offset level is set in the spectrum analyzer to compensate the RF cable loss and attenuator factor between EUT conducted output port and spectrum analyzer. With the offset compensation, the spectrum analyzer reading level is exactly the EUT RF output level.

Example :

The spectrum analyzer offset is derived from RF cable loss.

*Offset = RF cable loss.*

Following shows an offset computation example with cable loss 6 dB.

*Offset(dB) = RF cable loss(dB).*

*= 6 (dB)*

### 3 Test Result

#### 3.1 6dB Bandwidth Measurement

##### 3.1.1 Limit of 6dB Bandwidth

The minimum 6 dB bandwidth shall be at least 500 kHz.

##### 3.1.2 Measuring Instruments

The measuring equipment is listed in the section 4 of this test report.

##### 3.1.3 Test Procedures

1. The testing follows FCC KDB Publication No. 558074 DTS D01 Meas. Guidance v03r02.
2. The RF output of EUT was connected to the spectrum analyzer by RF cable and attenuator. The path loss was compensated to the results for each measurement.
3. Set to the maximum power setting and enable the EUT transmit continuously.
4. Make the measurement with the spectrum analyzer's resolution bandwidth (RBW) = 100 kHz. Set the Video bandwidth (VBW) = 300 kHz. In order to make an accurate measurement. The 6 dB bandwidth must be greater than 500 kHz.
5. Measure and record the results in the test report.

##### 3.1.4 Test Setup

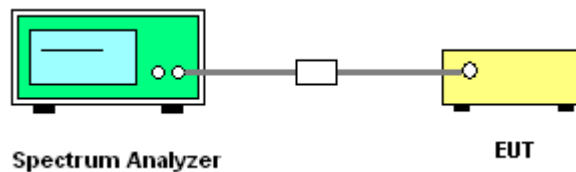



3.1.5 Test Result of 6dB Bandwidth

Test Band :	2.4GHz	Temperature :	24~25°C
Test Engineer :	Issac Song	Relative Humidity :	49~51%

Mod.	Data Rate	N <sub>TX</sub>	Channel	Freq. (MHz)	6dB Bandwidth (MHz)	6dB Bandwidth Min. Limit (MHz)	Pass/Fail
11b	1Mbps	1	1	2412	7.52	0.5	Pass
11b	1Mbps	1	6	2437	7.54	0.5	Pass
11b	1Mbps	1	11	2462	7.04	0.5	Pass
11g	6Mbps	1	1	2412	16.32	0.5	Pass
11g	6Mbps	1	6	2437	16.32	0.5	Pass
11g	6Mbps	1	11	2462	16.34	0.5	Pass
HT20	MCS0	1	1	2412	17.32	0.5	Pass
HT20	MCS0	1	6	2437	17.60	0.5	Pass
HT20	MCS0	1	11	2462	17.54	0.5	Pass

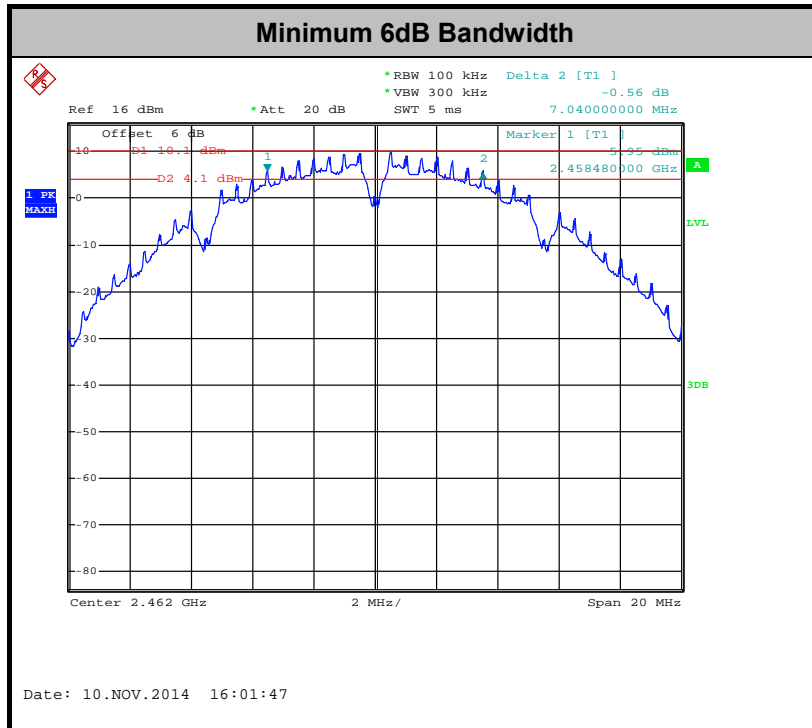

Note : The occupied channel bandwidth is maintained within the band of operation for all of the modulations.

## 3.2 Output Power Measurement

### 3.2.1 Limit of Output Power

For systems using digital modulation in the 2400-2483.5MHz, the limit for peak output power is 30dBm. If transmitting Antenna of directional gain greater than 6dBi are used the peak output power from the intentional radiator shall be reduced below the above stated value by the amount in dB that the directional gain of the Antenna exceeds 6 dBi. In case of point-to-point operation, the limit has to be reduced by 1dB for every 3dB that the directional gain of the Antenna exceeds 6dBi.

### 3.2.2 Measuring Instruments

The measuring equipment is listed in the section 4 of this test report.

### 3.2.3 Test Procedures

1. The testing follows the Measurement Procedure of FCC KDB No. 558074 DTS D01 Meas. Guidance v03r02.
2. The RF output of EUT was connected to the power meter by RF cable and attenuator. The path loss was compensated to the results for each measurement.
3. Set to the maximum power setting and enable the EUT transmit continuously.
4. Measure the conducted output power and record the results in the test report.

### 3.2.4 Test Setup

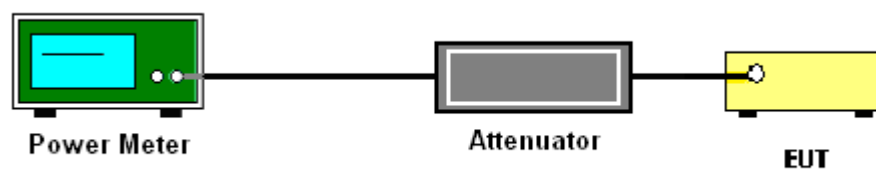



3.2.5 Test Result of Peak Output Power

Test Mode :	2.4GHz	Temperature :	24~25°C
Test Engineer :	Issac Song	Relative Humidity :	49~51%

Mod.	Data Rate	N <sub>TX</sub>	Channel	Freq. (MHz)	RF Output Power (dBm)	Power Limit (dBm)	DG (dBi)	Pass/Fail
11b	1Mbps	1	1	2412	18.80	30	-4.60	Pass
11b	1Mbps	1	6	2437	19.25	30	-4.60	Pass
11b	1Mbps	1	11	2462	20.02	30	-4.60	Pass
11g	6Mbps	1	1	2412	19.67	30	-4.60	Pass
11g	6Mbps	1	6	2437	19.99	30	-4.60	Pass
11g	6Mbps	1	11	2462	20.48	30	-4.60	Pass
HT20	MCS0	1	1	2412	19.24	30	-4.60	Pass
HT20	MCS0	1	6	2437	19.52	30	-4.60	Pass
HT20	MCS0	1	11	2462	19.85	30	-4.60	Pass

Note: Measured power (dBm) has offset with cable loss.



**3.2.6 Test Result of Average output Power (Reporting Only)**

Test Mode :	2.4GHz	Temperature :	24~25°C
Test Engineer :	Issac Song	Relative Humidity :	49~51%

Mod.	Data Rate	N <sub>TX</sub>	Channel	Freq. (MHz)	Duty Factor (dB)	Average Output Power (dBm)	Power Limit (dBm)	DG (dBi)	Pass/Fail
11b	1Mbps	1	1	2412	0.10	16.03	30	-4.60	Pass
11b	1Mbps	1	6	2437	0.10	16.31	30	-4.60	Pass
11b	1Mbps	1	11	2462	0.10	17.33	30	-4.60	Pass
11g	6Mbps	1	1	2412	0.59	10.54	30	-4.60	Pass
11g	6Mbps	1	6	2437	0.59	11.05	30	-4.60	Pass
11g	6Mbps	1	11	2462	0.59	11.95	30	-4.60	Pass
HT20	MCS0	1	1	2412	0.63	9.72	30	-4.60	Pass
HT20	MCS0	1	6	2437	0.63	10.23	30	-4.60	Pass
HT20	MCS0	1	11	2462	0.63	11.16	30	-4.60	Pass

**Note:** Measured power (dBm) has offset with cable loss and duty factor.

### 3.3 Power Spectral Density Measurement

#### 3.3.1 Limit of Power Spectral Density

The peak power spectral density shall not be greater than 8dBm in any 3kHz band at any time interval of continuous transmission.

#### 3.3.2 Measuring Instruments

The measuring equipment is listed in the section 4 of this test report.

#### 3.3.3 Test Procedures

1. The testing follows Measurement Procedure 10.2 Method PKPSD of FCC KDB Publication No. 558074 D01 DTS Meas. Guidance v03r02
2. The RF output of EUT was connected to the spectrum analyzer by RF cable and attenuator. The path loss was compensated to the results for each measurement.
3. Set to the maximum power setting and enable the EUT transmit continuously.
4. Make the measurement with the spectrum analyzer's resolution bandwidth (RBW) = 3 kHz. Video bandwidth VBW = 10 kHz In order to make an accurate measurement, set the span to 1.5 times DTS Channel Bandwidth. (6dB BW)
5. Detector = peak, Sweep time = auto couple, Trace mode = max hold, Allow trace to fully stabilize. Use the peak marker function to determine the maximum power level.
6. Measure and record the results in the test report.

#### 3.3.4 Test Setup

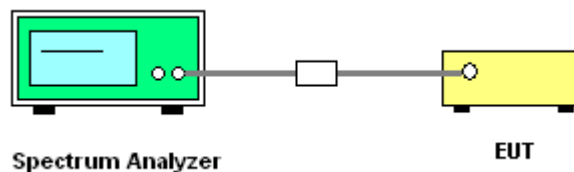



3.3.5 Test Result of Power Spectral Density

Test Mode :	2.4GHz	Temperature :	24~25°C
Test Engineer :	Issac Song	Relative Humidity :	49~51%

Mod.	Data Rate	N <sub>TX</sub>	Channel	Freq. (MHz)	Peak Power Density (dBm/3kHz)	Max. Limits (dBm/3kHz)	DG (dBi)	Pass/Fail
11b	1Mbps	1	1	2412	-5.25	8	-4.60	Pass
11b	1Mbps	1	6	2437	-5.19	8	-4.60	Pass
11b	1Mbps	1	11	2462	-3.82	8	-4.60	Pass
11g	6Mbps	1	1	2412	-14.41	8	-4.60	Pass
11g	6Mbps	1	6	2437	-16.52	8	-4.60	Pass
11g	6Mbps	1	11	2462	-13.05	8	-4.60	Pass
HT20	MCS0	1	1	2412	-14.10	8	-4.60	Pass
HT20	MCS0	1	6	2437	-15.84	8	-4.60	Pass
HT20	MCS0	1	11	2462	-14.74	8	-4.60	Pass

**Note:** Measured power density (dBm) has offset with cable loss.

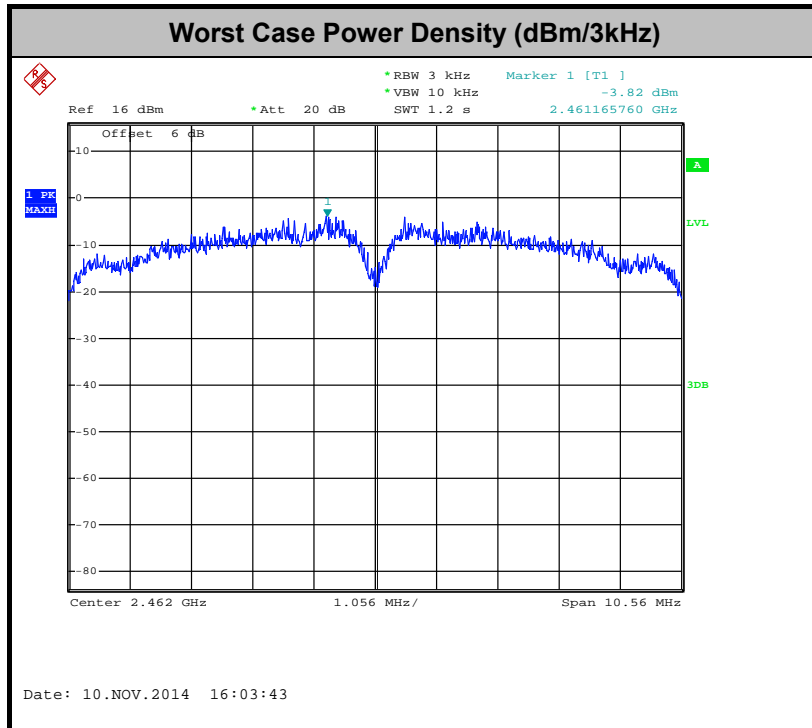

## 3.4 Conducted Band Edges and Spurious Emission Measurement

### 3.4.1 Limit of Conducted Band Edges and Spurious Emission Measurement

In any 100 kHz bandwidth outside of the authorized frequency band, the emissions which fall in the non-restricted bands shall be attenuated at least 20 dB / 30dB relative to the maximum PSD level in 100 kHz by RF conducted measurement and radiated emissions which fall in the restricted bands, as defined in Section 15.205(a), must also comply with the radiated emission limits specified in Section 15.209(a).

### 3.4.2 Measuring Instruments

The measuring equipment is listed in the section 4 of this test report.

### 3.4.3 Test Procedures

1. The testing follows FCC KDB Publication No. 558074 D01 DTS Meas. Guidance v03r02.
2. The RF output of EUT was connected to the spectrum analyzer by RF cable and attenuator. The path loss was compensated to the results for each measurement.
3. Set to the maximum power setting and enable the EUT transmit continuously.
4. Set RBW = 100 kHz, VBW=300 kHz, Peak Detector. Unwanted Emissions measured in any 100 kHz bandwidth outside of the authorized frequency band shall be attenuated by at least 20 dB relative to the maximum in-band peak PSD level in 100 kHz when maximum peak conducted output power procedure is used. If the transmitter complies with the conducted power limits based on the use of RMS averaging over a time interval, the attenuation required under this paragraph shall be 30 dB instead of 20 dB per 15.247(d).
5. Measure and record the results in the test report.
6. The RF fundamental frequency should be excluded against the limit line in the operating frequency band.

### 3.4.4 Test Setup

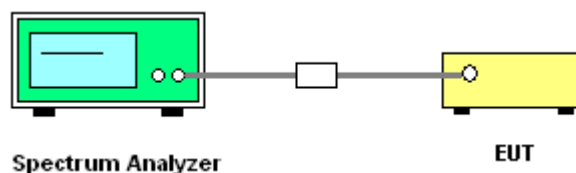



### 3.4.5 Test Result of Conducted Band Edges and Spurious Emission

Test Mode :	802.11b	Temperature :	24~25°C
Test Band :	2.4GHz Low	Relative Humidity :	49~51%
Test Channel :	01	Test Engineer :	Issac Song

#### WLAN 802.11b Channel 01

##### 100kHz PSD reference Level

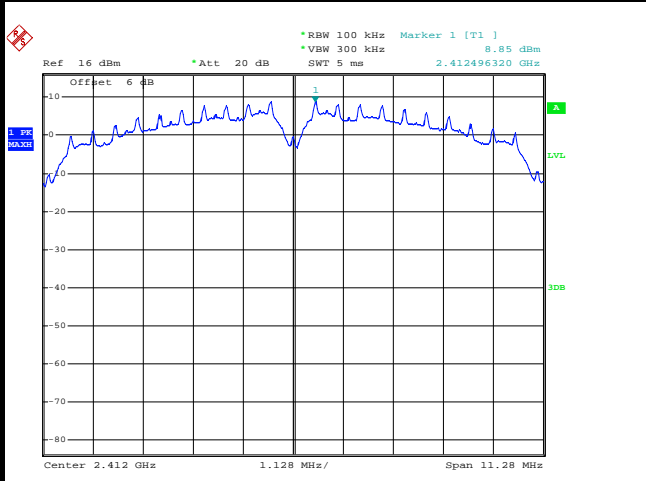

Date: 10.NOV.2014 15:53:51

##### Low Channel Plot

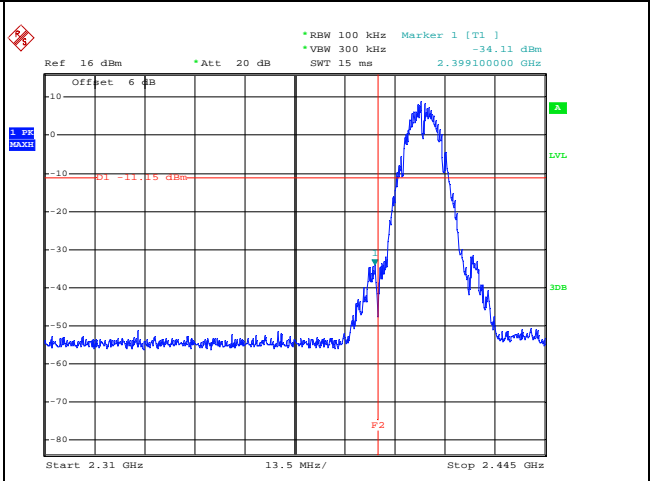

Date: 10.NOV.2014 15:54:11

##### Spurious Emission 30MHz~3GHz

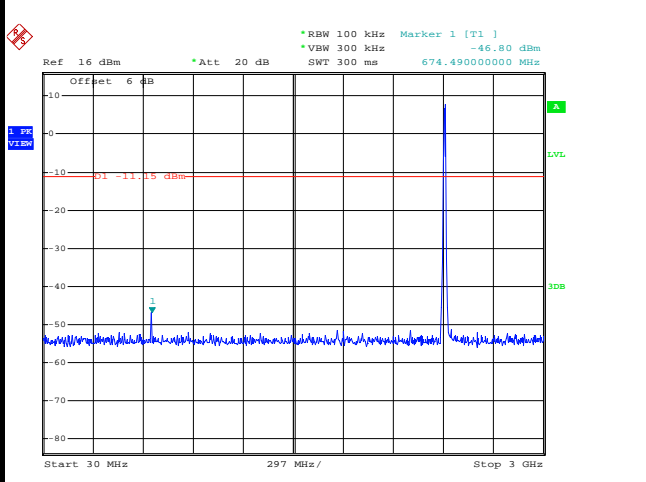

Date: 10.NOV.2014 15:54:36

##### Spurious Emission 2GHz~25GHz

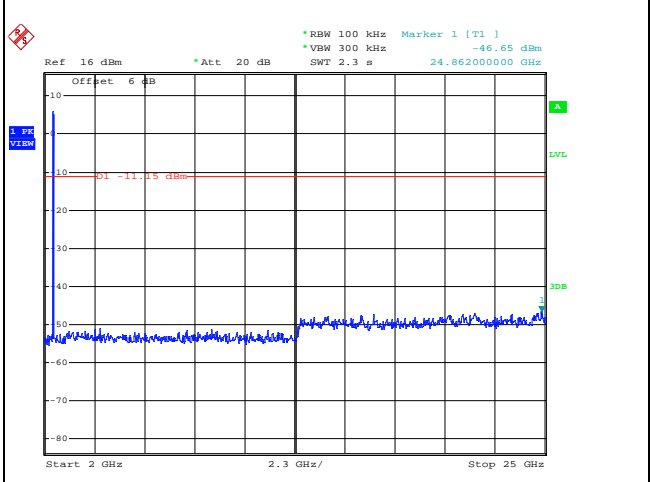

Date: 10.NOV.2014 15:54:54



Test Mode :	802.11b	Temperature :	24~25°C
Test Band :	2.4GHz Mid	Relative Humidity :	49~51%
Test Channel :	06	Test Engineer :	Issac Song

WLAN 802.11b Channel 06

100kHz PSD reference Level

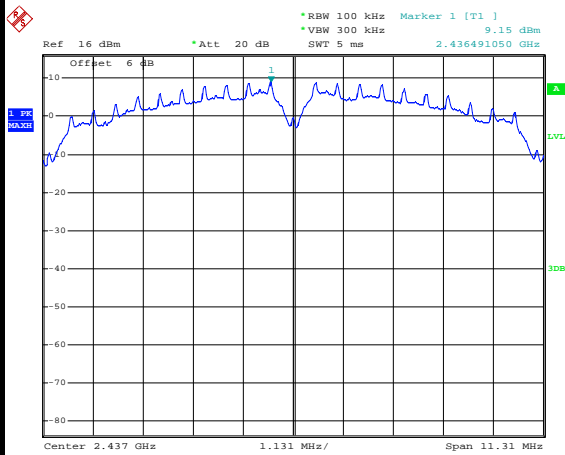

Date: 10.NOV.2014 15:58:33

Spurious Emission 30MHz~3GHz

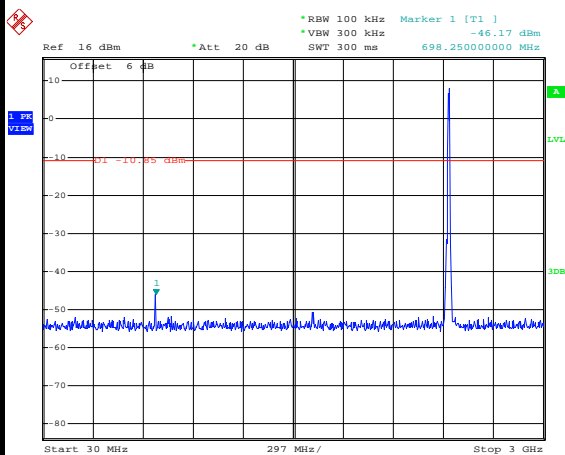

Date: 10.NOV.2014 15:58:57

Spurious Emission 2GHz~25GHz

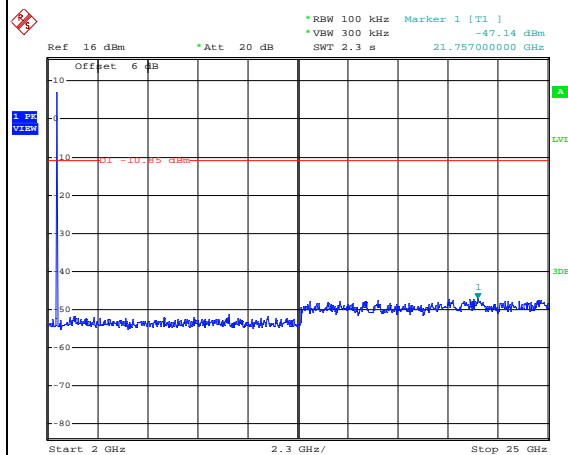

Date: 10.NOV.2014 15:59:15



Test Mode :	802.11b	Temperature :	24~25°C
Test Band :	2.4GHz High	Relative Humidity :	49~51%
Test Channel :	11	Test Engineer :	Issac Song

WLAN 802.11b Channel 11

100kHz PSD reference Level

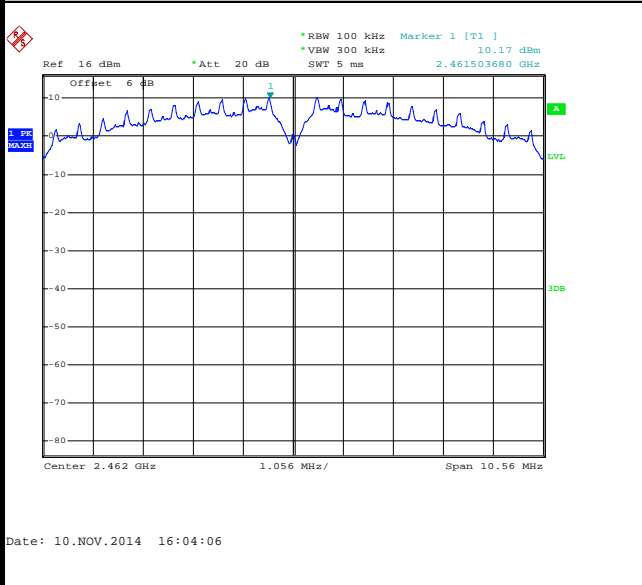

High Channel Plot

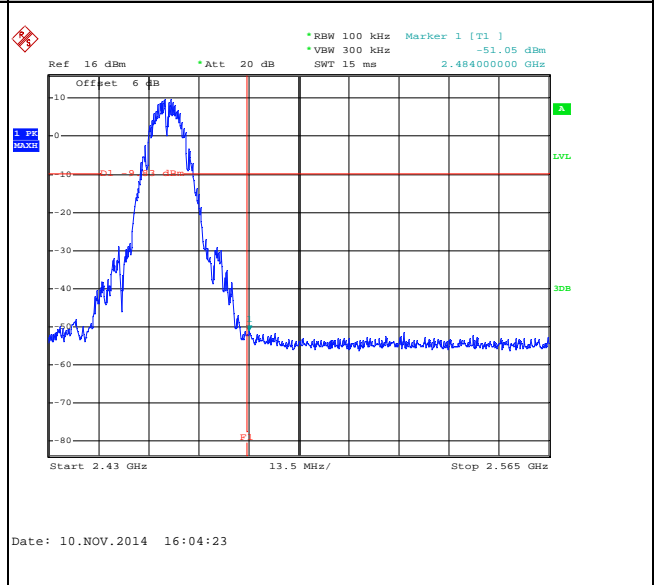

Spurious Emission 30MHz~3GHz

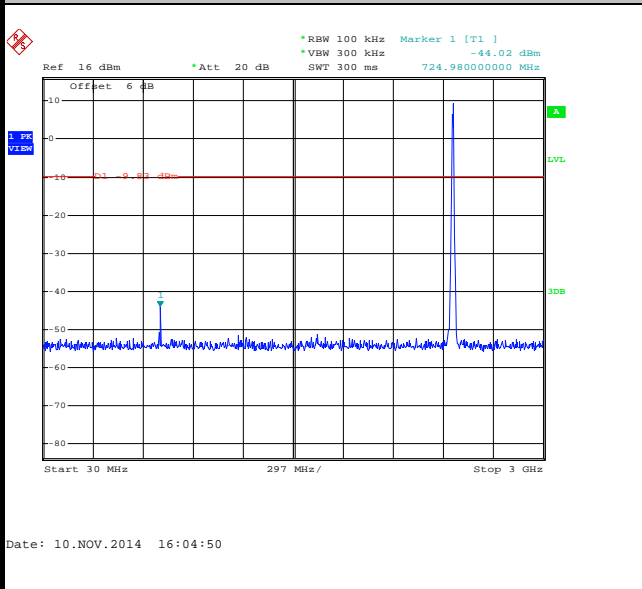

Spurious Emission 2GHz~25GHz

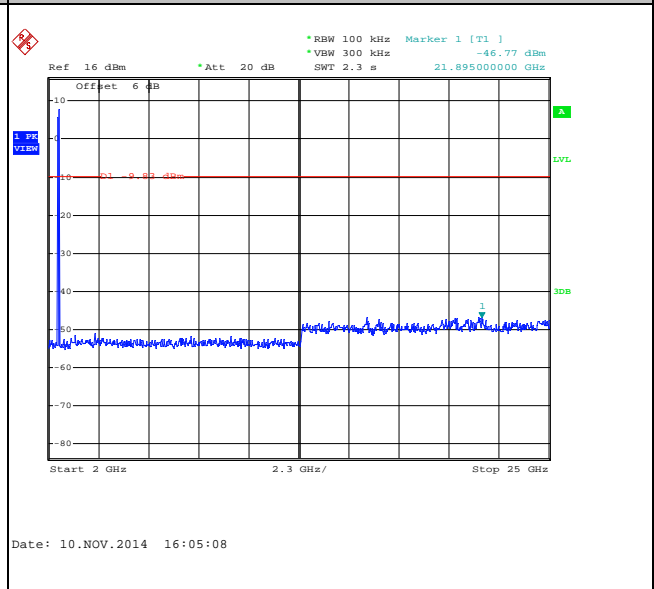





Test Mode :	802.11g	Temperature :	24~25°C
Test Band :	2.4GHz Low	Relative Humidity :	49~51%
Test Channel :	01	Test Engineer :	Issac Song

WLAN 802.11g Channel 01

100kHz PSD reference Level

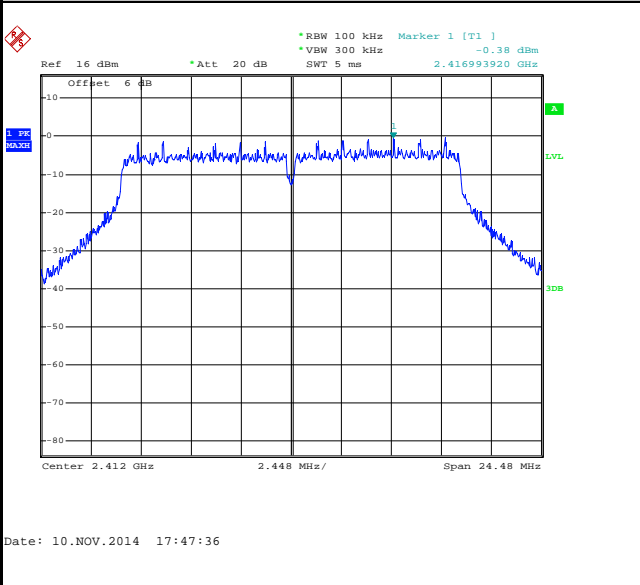

Low Channel Plot

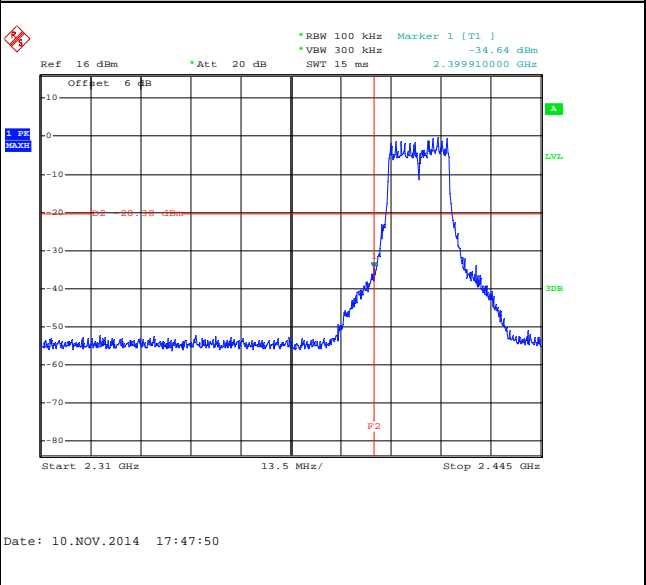

Spurious Emission 30MHz~3GHz

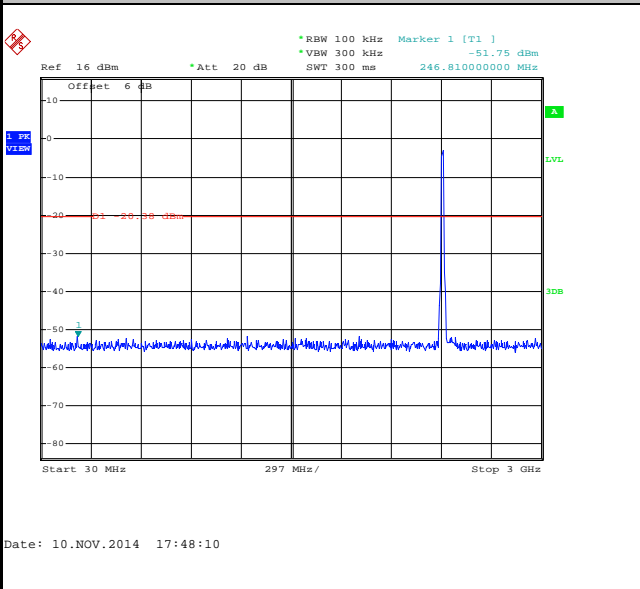

Spurious Emission 2GHz~25GHz

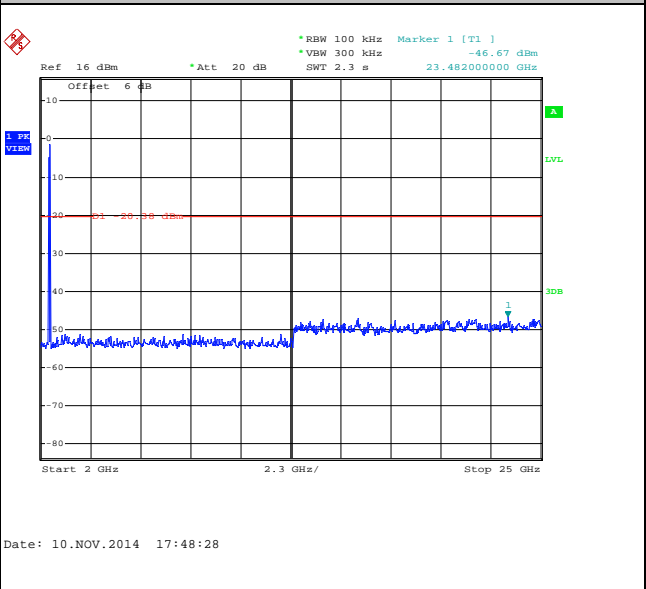



Test Mode :	802.11g	Temperature :	24~25°C
Test Band :	2.4GHz Mid	Relative Humidity :	49~51%
Test Channel :	06	Test Engineer :	Issac Song

WLAN 802.11g Channel 06

100kHz PSD reference Level

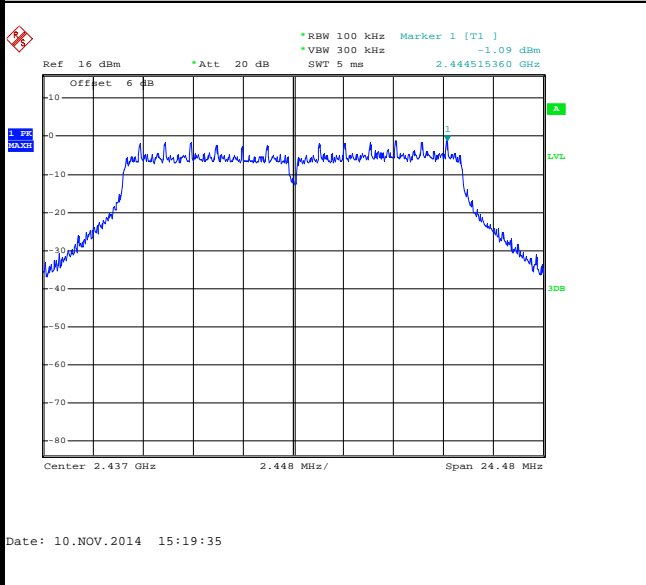

Spurious Emission 30MHz~3GHz

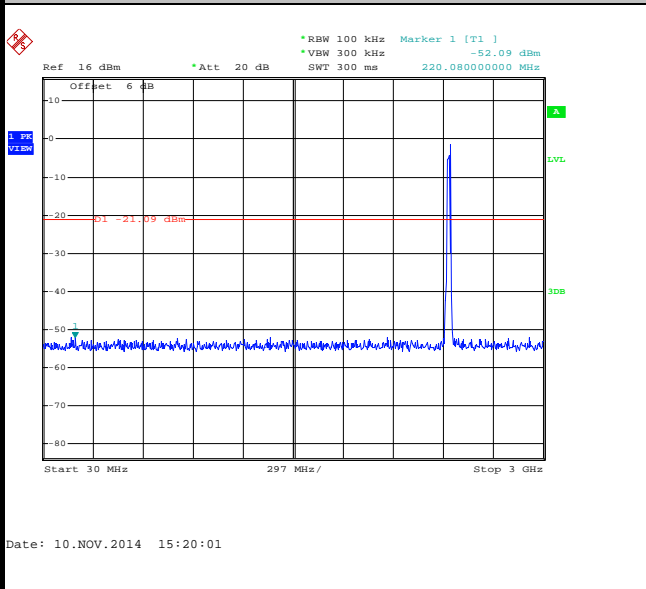

Spurious Emission 2GHz~25GHz

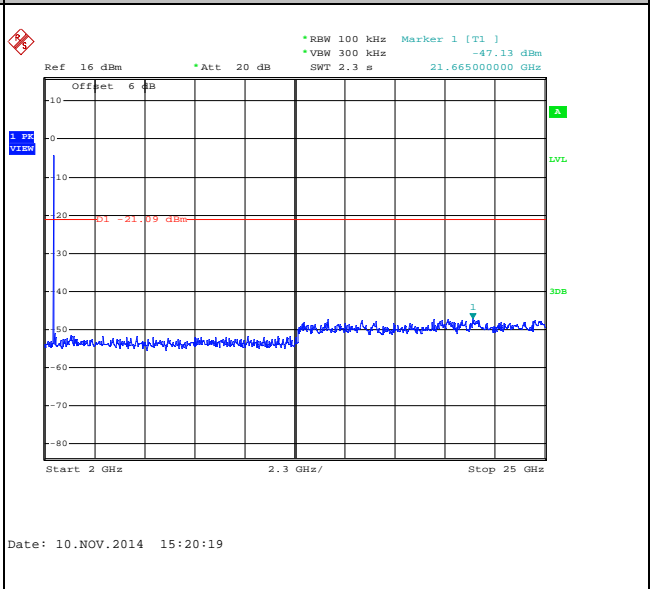



Test Mode :	802.11g	Temperature :	24~25°C
Test Band :	2.4GHz High	Relative Humidity :	49~51%
Test Channel :	11	Test Engineer :	Issac Song

WLAN 802.11g Channel 11

100kHz PSD reference Level

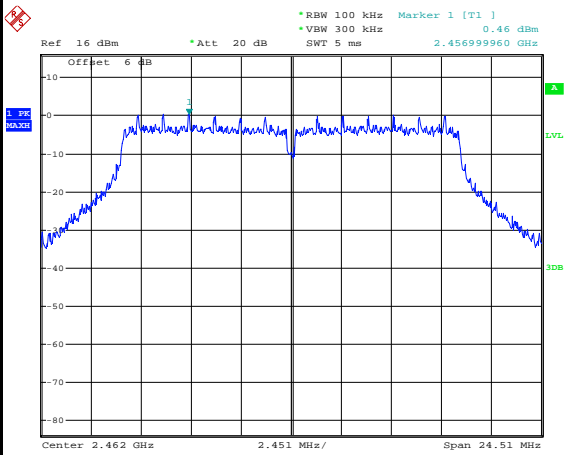

Date: 10.NOV.2014 15:24:10

High Channel Plot

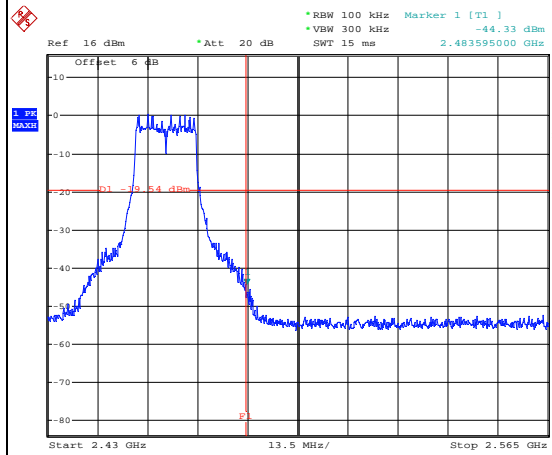

Date: 10.NOV.2014 15:24:34

Spurious Emission 30MHz~3GHz

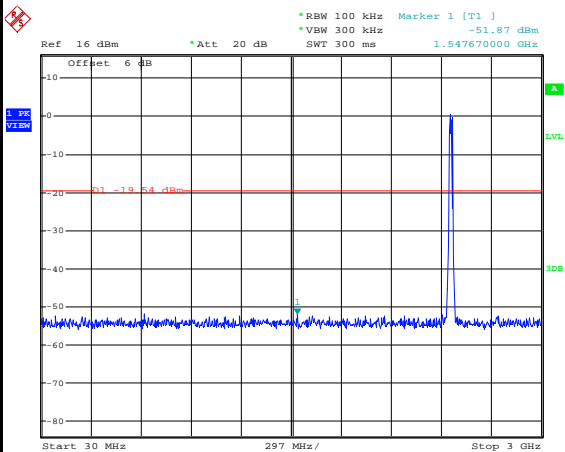

Date: 10.NOV.2014 15:25:03

Spurious Emission 2GHz~25GHz

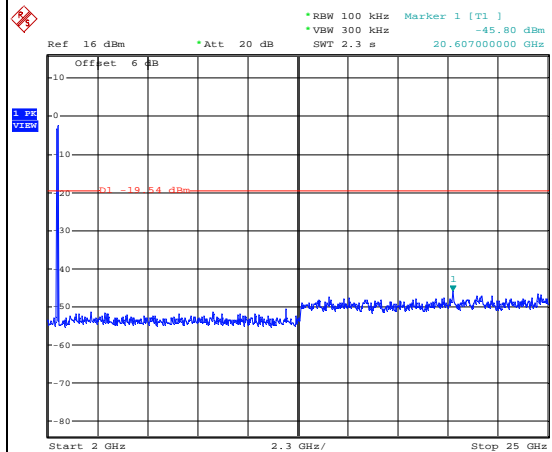

Date: 10.NOV.2014 15:25:21



Test Mode :	802.11n HT20	Temperature :	24~25°C
Test Band :	2.4GHz Low	Relative Humidity :	49~51%
Test Channel :	01	Test Engineer :	Issac Song

WLAN 802.11n HT20 Channel 01

100kHz PSD reference Level

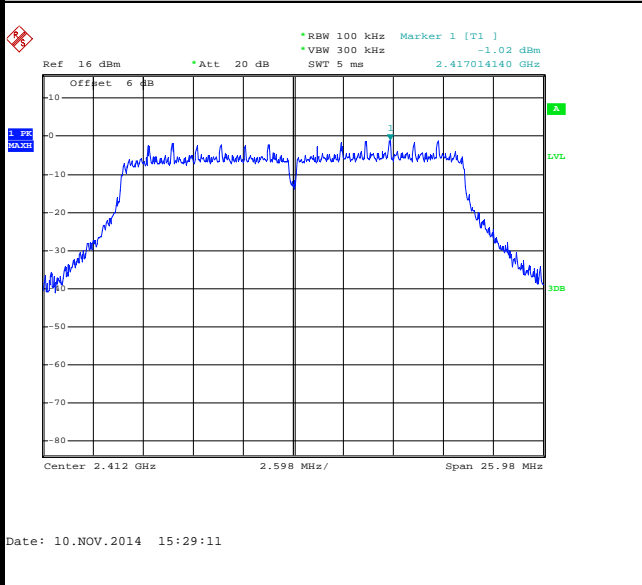

Low Channel Plot

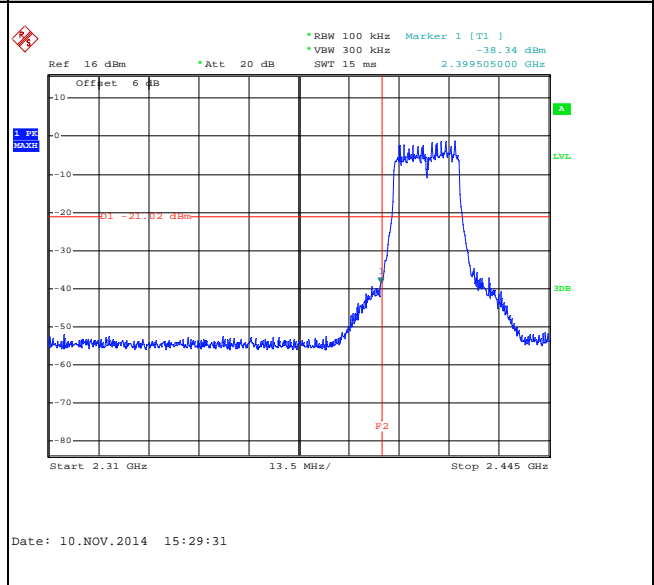

Spurious Emission 30MHz~3GHz

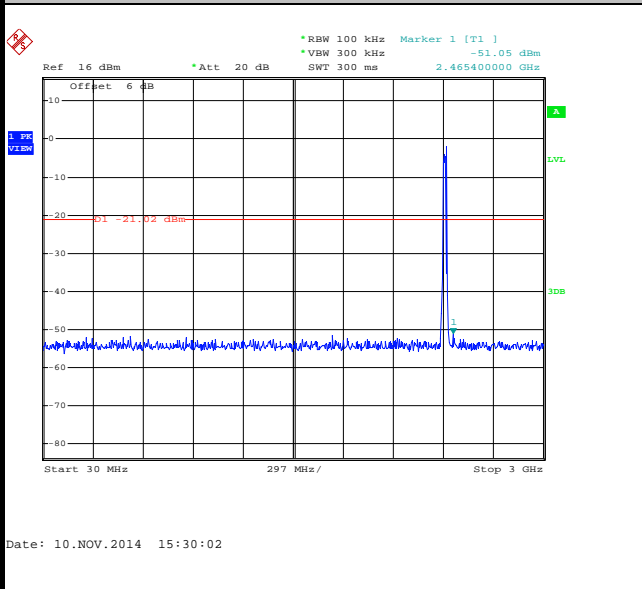

Spurious Emission 2GHz~25GHz

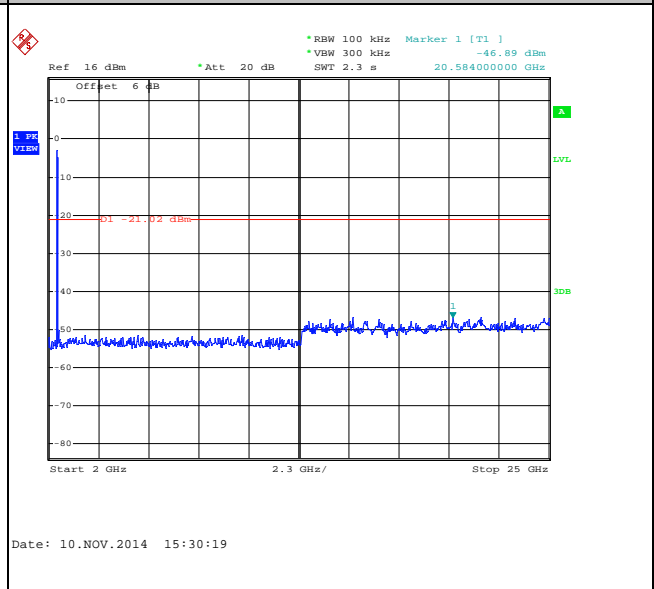



Test Mode :	802.11n HT20	Temperature :	24~25°C
Test Band :	2.4GHz Mid	Relative Humidity :	49~51%
Test Channel :	06	Test Engineer :	Issac Song

WLAN 802.11n HT20 Channel 06

100kHz PSD reference Level

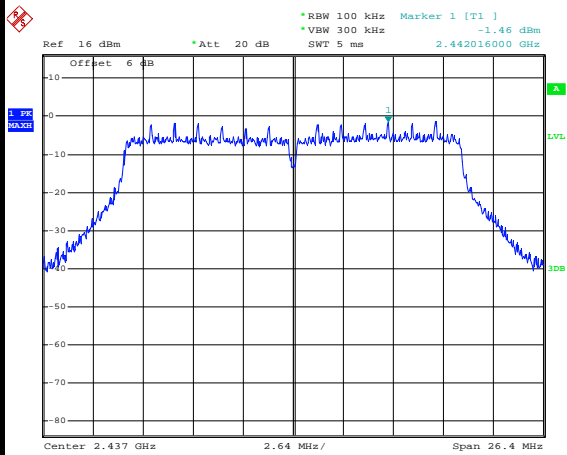

Date: 10.NOV.2014 15:33:07

Spurious Emission 30MHz~3GHz

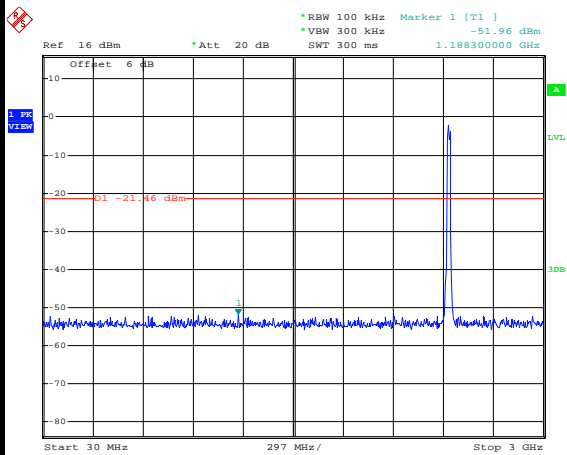

Date: 10.NOV.2014 15:33:56

Spurious Emission 2GHz~25GHz

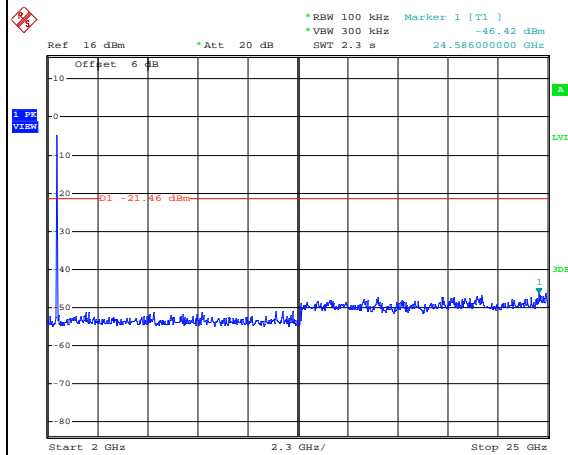

Date: 10.NOV.2014 15:34:14



Test Mode :	802.11n HT20	Temperature :	24~25°C
Test Band :	2.4GHz High	Relative Humidity :	49~51%
Test Channel :	11	Test Engineer :	Issac Song

WLAN 802.11n HT20 Channel 11

100kHz PSD reference Level

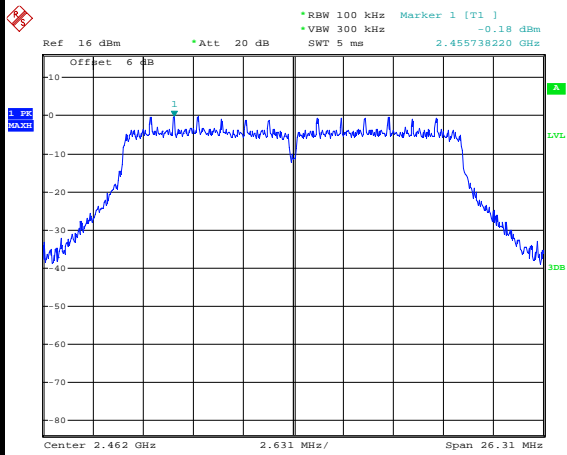

Date: 10.NOV.2014 15:37:03

High Channel Plot

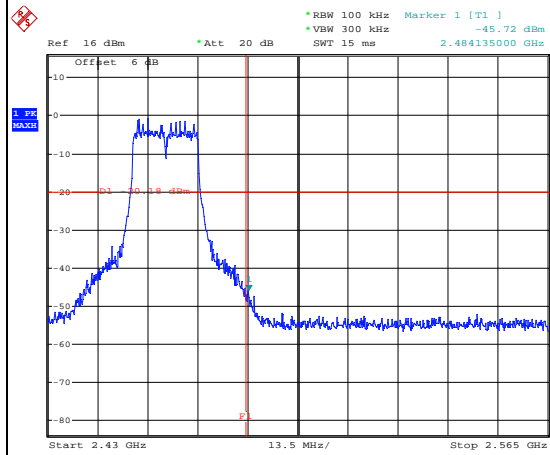

Date: 10.NOV.2014 15:38:19

Spurious Emission 30MHz~3GHz

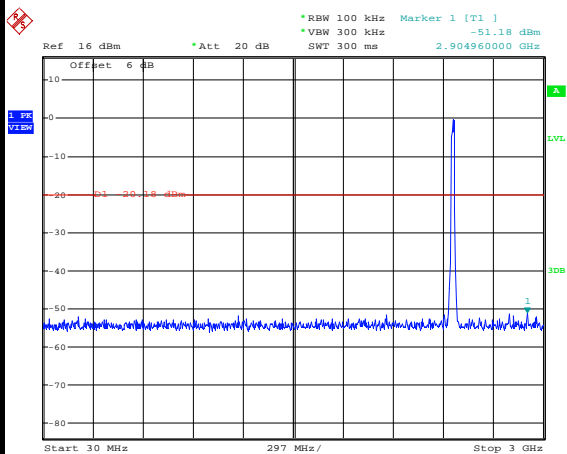

Date: 10.NOV.2014 15:38:45

Spurious Emission 2GHz~25GHz

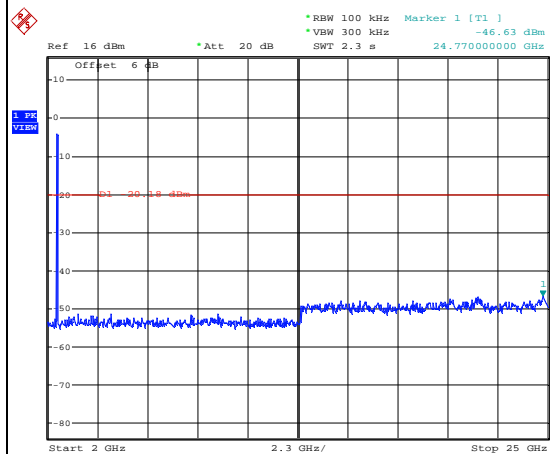

Date: 10.NOV.2014 15:39:03



### 3.5 Radiated Band Edges and Spurious Emission Measurement

#### 3.5.1 Limit of Radiated band edge and Spurious Emission Measurement

In any 100 kHz bandwidth outside the intentional radiator frequency band, all harmonics/spurious must be at least 20 dB below the highest emission level within the authorized band. If the output power of this device was measured by spectrum analyzer, the attenuation under this paragraph shall be 30 dB instead of 20 dB. In addition, radiated emissions which fall in the restricted bands must also comply with the FCC section 15.209 limits as below.

Frequency (MHz)	Field Strength (microvolts/meter)	Measurement Distance (meters)
0.009 – 0.490	2400/F(kHz)	300
0.490 – 1.705	24000/F(kHz)	30
1.705 – 30.0	30	30
30 – 88	100	3
88 – 216	150	3
216 - 960	200	3
Above 960	500	3

#### 3.5.2 Measuring Instruments

The measuring equipment is listed in the section 4 of this test report.



3.5.3 Test Procedures

1. The testing follows FCC KDB Publication No. 558074 D01 DTS Meas. Guidance v03r02.
2. The EUT was arranged to its worst case and then tune the antenna tower (from 1 m to 4 m) and turntable (from 0 degree to 360 degrees) to find the maximum reading. A pre-amp and a high pass filter are used for the test in order to get better signal level.
3. The EUT was placed on a turntable with 0.8 meter above ground.
4. The EUT was set 3 meters from the interference receiving antenna, which was mounted on the top of a variable height antenna tower.
5. Corrected Reading: Antenna Factor + Cable Loss + Read Level - Preamp Factor = Level
6. For measurement below 1GHz, If the emission level of the EUT measured by the peak detector is 3 dB lower than the applicable limit, the peak emission level will be reported. Otherwise, the emission measurement will be repeated using the quasi-peak detector and reported.
7. Use the following spectrum analyzer settings:
  - (1) Span shall wide enough to fully capture the emission being measured;
  - (2) Set RBW=100 kHz for  $f < 1$  GHz;  $VBW \geq RBW$ ; Sweep = auto; Detector function = peak; Trace = max hold;
  - (3) Set RBW = 1 MHz, VBW= 3MHz for  $f \geq 1$  GHz for peak measurement.

For average measurement:

  - $VBW = 10$  Hz, when duty cycle is no less than 98 percent.
  - $VBW \geq 1/T$ , when duty cycle is less than 98 percent where T is the minimum transmission duration over which the transmitter is on and is transmitting at its maximum power control level for the tested mode of operation.

Band	Duty Cycle(%)	T(ms)	1/T(kHz)	VBW Setting
802.11b	97.63	8.24	0.12	300Hz
802.11g	87.26	1.37	0.73	1kHz
2.4GHz 802.11n HT20	86.50	1.28	0.78	1kHz



### 3.5.4 Test Setup

For radiated emissions below 30MHz

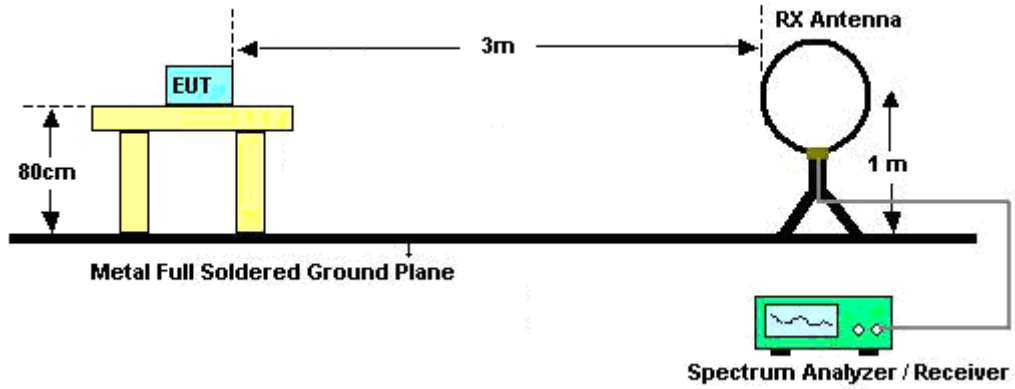

For radiated emissions from 30MHz to 1GHz

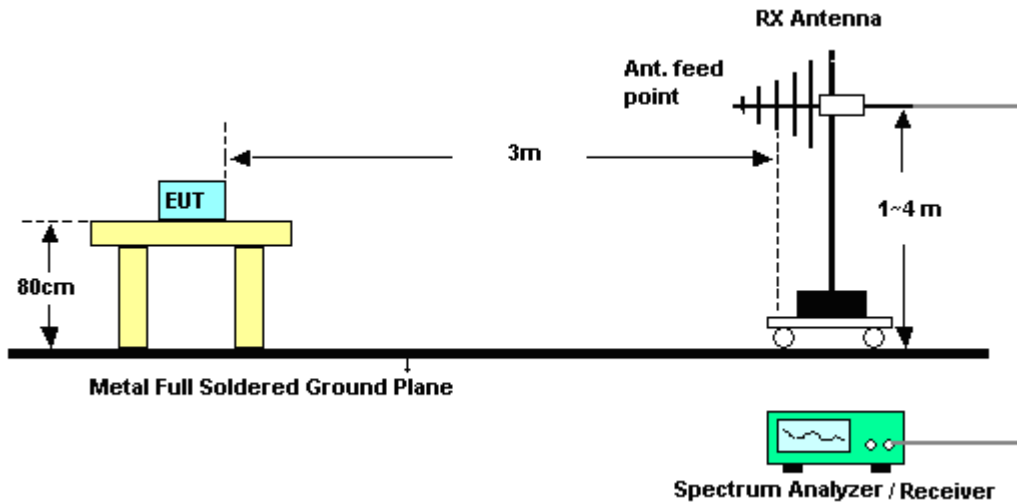

For radiated emissions above 1GHz

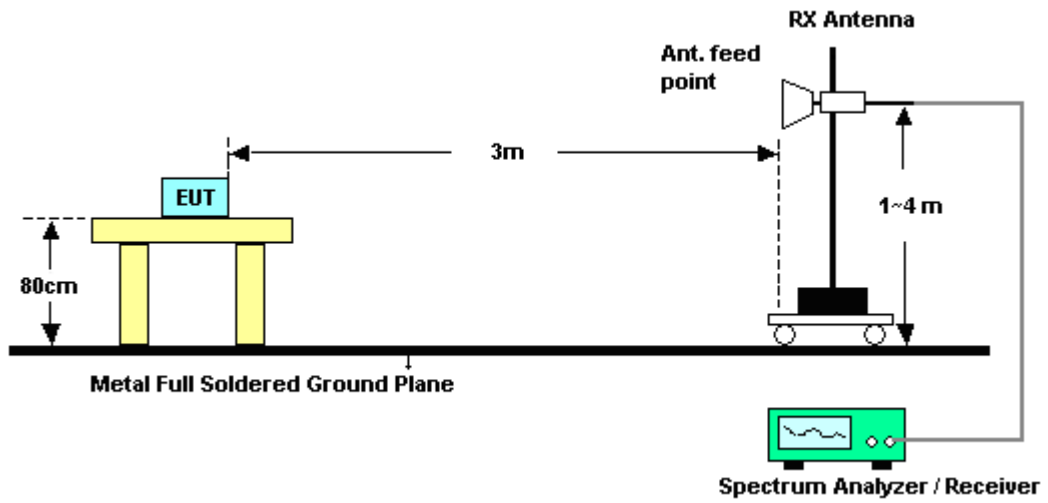

### 3.5.5 Test Results of Radiated Spurious Emissions (9kHz ~ 30MHz)

The low frequency, which started from 9 kHz to 30MHz, was pre-scanned and the result which was 20dB lower than the limit line per 15.31(o) was not reported.



3.5.6 Test Result of Radiated Spurious at Band Edges

Test Mode :	802.11b	Temperature :	22~23°C
Test Band :	Low	Relative Humidity :	40~41%
Test Channel :	01	Test Engineer :	Nick Su

ANTENNA POLARITY : HORIZONTAL										
Frequency ( MHz )	Level ( dBμV/m )	Over Limit ( dB )	Limit Line ( dBμV/m )	Read Level ( dBμV )	Antenna Factor ( dB )	Cable Loss ( dB )	Preamp Factor ( dB )	Ant Pos ( cm )	Table Pos ( deg )	Remark
2388.21	51.21	-22.79	74	49.11	32.01	6.17	36.08	121	299	Peak
2387.49	40.44	-13.56	54	38.34	32.01	6.17	36.08	121	299	Average

ANTENNA POLARITY : VERTICAL										
Frequency ( MHz )	Level ( dBμV/m )	Over Limit ( dB )	Limit Line ( dBμV/m )	Read Level ( dBμV )	Antenna Factor ( dB )	Cable Loss ( dB )	Preamp Factor ( dB )	Ant Pos ( cm )	Table Pos ( deg )	Remark
2349.6	49.88	-24.12	74	48.28	31.82	6.12	36.34	100	183	Peak
2387.4	38.37	-15.63	54	36.27	32.01	6.17	36.08	100	183	Average

Test Mode :	802.11b	Temperature :	22~23°C
Test Band :	High	Relative Humidity :	40~41%
Test Channel :	11	Test Engineer :	Nick Su

ANTENNA POLARITY : HORIZONTAL										
Frequency ( MHz )	Level ( dBμV/m )	Over Limit ( dB )	Limit Line ( dBμV/m )	Read Level ( dBμV )	Antenna Factor ( dB )	Cable Loss ( dB )	Preamp Factor ( dB )	Ant Pos ( cm )	Table Pos ( deg )	Remark
2486.77	52.44	-21.56	74	49.56	32.34	6.33	35.79	115	297	Peak
2484.7	39.64	-14.36	54	36.76	32.34	6.33	35.79	115	297	Average

ANTENNA POLARITY : VERTICAL										
Frequency ( MHz )	Level ( dBμV/m )	Over Limit ( dB )	Limit Line ( dBμV/m )	Read Level ( dBμV )	Antenna Factor ( dB )	Cable Loss ( dB )	Preamp Factor ( dB )	Ant Pos ( cm )	Table Pos ( deg )	Remark
2486.65	51.66	-22.34	74	48.78	32.34	6.33	35.79	174	261	Peak
2484.52	39.28	-14.72	54	36.4	32.34	6.33	35.79	174	261	Average



Test Mode :	802.11g	Temperature :	22~23°C
Test Band :	Low	Relative Humidity :	40~41%
Test Channel :	01	Test Engineer :	Nick Su

ANTENNA POLARITY : HORIZONTAL										
Frequency ( MHz )	Level ( dBμV/m )	Over Limit ( dB )	Limit Line ( dBμV/m )	Read Level ( dBμV )	Antenna Factor ( dB )	Cable Loss ( dB )	Preamp Factor ( dB )	Ant Pos ( cm )	Table Pos ( deg )	Remark
2389.83	61.97	-12.03	74	59.87	32.01	6.17	36.08	114	331	Peak
2390	42.93	-11.07	54	40.83	32.01	6.17	36.08	114	331	Average

ANTENNA POLARITY : VERTICAL										
Frequency ( MHz )	Level ( dBμV/m )	Over Limit ( dB )	Limit Line ( dBμV/m )	Read Level ( dBμV )	Antenna Factor ( dB )	Cable Loss ( dB )	Preamp Factor ( dB )	Ant Pos ( cm )	Table Pos ( deg )	Remark
2366.79	50.14	-23.86	74	48.33	31.89	6.17	36.25	103	182	Peak
2389.83	38.79	-15.21	54	36.69	32.01	6.17	36.08	103	182	Average

Test Mode :	802.11g	Temperature :	22~23°C
Test Band :	High	Relative Humidity :	40~41%
Test Channel :	11	Test Engineer :	Nick Su

ANTENNA POLARITY : HORIZONTAL										
Frequency ( MHz )	Level ( dBμV/m )	Over Limit ( dB )	Limit Line ( dBμV/m )	Read Level ( dBμV )	Antenna Factor ( dB )	Cable Loss ( dB )	Preamp Factor ( dB )	Ant Pos ( cm )	Table Pos ( deg )	Remark
2483.68	66.4	-7.6	74	63.52	32.34	6.33	35.79	144	300	Peak
2483.5	42.3	-11.7	54	39.42	32.34	6.33	35.79	144	300	Average

ANTENNA POLARITY : VERTICAL										
Frequency ( MHz )	Level ( dBμV/m )	Over Limit ( dB )	Limit Line ( dBμV/m )	Read Level ( dBμV )	Antenna Factor ( dB )	Cable Loss ( dB )	Preamp Factor ( dB )	Ant Pos ( cm )	Table Pos ( deg )	Remark
2483.53	55.5	-18.5	74	52.62	32.34	6.33	35.79	123	168	Peak
2484.07	39.1	-14.9	54	36.22	32.34	6.33	35.79	123	168	Average



Test Mode :	802.11n HT20	Temperature :	22~23°C
Test Band :	Low	Relative Humidity :	40~41%
Test Channel :	01	Test Engineer :	Nick Su

ANTENNA POLARITY : HORIZONTAL										
Frequency ( MHz )	Level ( dBμV/m )	Over Limit ( dB )	Limit Line ( dBμV/m )	Read Level ( dBμV )	Antenna Factor ( dB )	Cable Loss ( dB )	Preamp Factor ( dB )	Ant Pos ( cm )	Table Pos ( deg )	Remark
2389.11	60.72	-13.28	74	58.62	32.01	6.17	36.08	100	323	Peak
2390	40.71	-13.29	54	38.61	32.01	6.17	36.08	100	323	Average

ANTENNA POLARITY : VERTICAL										
Frequency ( MHz )	Level ( dBμV/m )	Over Limit ( dB )	Limit Line ( dBμV/m )	Read Level ( dBμV )	Antenna Factor ( dB )	Cable Loss ( dB )	Preamp Factor ( dB )	Ant Pos ( cm )	Table Pos ( deg )	Remark
2388.3	62.56	-11.44	74	60.46	32.01	6.17	36.08	127	262	Peak
2390	41.44	-12.56	54	39.34	32.01	6.17	36.08	127	262	Average

Test Mode :	802.11n HT20	Temperature :	22~23°C
Test Band :	High	Relative Humidity :	40~41%
Test Channel :	11	Test Engineer :	Nick Su

ANTENNA POLARITY : HORIZONTAL										
Frequency ( MHz )	Level ( dBμV/m )	Over Limit ( dB )	Limit Line ( dBμV/m )	Read Level ( dBμV )	Antenna Factor ( dB )	Cable Loss ( dB )	Preamp Factor ( dB )	Ant Pos ( cm )	Table Pos ( deg )	Remark
2484.13	56.74	-17.26	74	53.86	32.34	6.33	35.79	101	35	Peak
2483.56	39.14	-14.86	54	36.26	32.34	6.33	35.79	101	26	Average

ANTENNA POLARITY : VERTICAL										
Frequency ( MHz )	Level ( dBμV/m )	Over Limit ( dB )	Limit Line ( dBμV/m )	Read Level ( dBμV )	Antenna Factor ( dB )	Cable Loss ( dB )	Preamp Factor ( dB )	Ant Pos ( cm )	Table Pos ( deg )	Remark
2484.1	63.87	-10.13	74	60.99	32.34	6.33	35.79	101	238	Peak
2483.5	41.25	-12.75	54	38.37	32.34	6.33	35.79	101	238	Average



### 3.5.7 Test Result of Radiated Spurious Emission (30MHz ~ 10<sup>th</sup> Harmonic)

**Note:** Pre-scanned all test modes and only choose the worst case mode recorded in the test report for radiated spurious emission below 1GHz.

<b>Test Mode :</b>	802.11b	<b>Temperature :</b>	22~23°C
<b>Test Channel :</b>	01	<b>Relative Humidity :</b>	40~41%
<b>Test Engineer :</b>	Nick Su	<b>Polarization :</b>	Horizontal
<b>Remark :</b>	1. 2412 MHz is fundamental signal which can be ignored. 2. Average measurement was not performed if peak level went lower than the average limit.		

Frequency ( MHz )	Level ( dBμV/m )	Over Limit ( dB )	Limit Line ( dBμV/m )	Read Level ( dBμV )	Antenna Factor ( dB )	Cable Loss ( dB )	Preamp Factor ( dB )	Ant Pos ( cm )	Table Pos ( deg )	Remark
2412	108.2	-	-	105.92	32.08	6.22	36.02	121	299	Peak
2412	103.29	-	-	101.01	32.08	6.22	36.02	121	299	Average
4824	45.59	-28.41	74	39.31	34.2	8.73	36.65	100	46	Peak

<b>Test Mode :</b>	802.11b	<b>Temperature :</b>	22~23°C
<b>Test Channel :</b>	01	<b>Relative Humidity :</b>	40~41%
<b>Test Engineer :</b>	Nick Su	<b>Polarization :</b>	Vertical
<b>Remark :</b>	1. 2412 MHz is fundamental signal which can be ignored. 2. Average measurement was not performed if peak level went lower than the average limit.		

Frequency ( MHz )	Level ( dBμV/m )	Over Limit ( dB )	Limit Line ( dBμV/m )	Read Level ( dBμV )	Antenna Factor ( dB )	Cable Loss ( dB )	Preamp Factor ( dB )	Ant Pos ( cm )	Table Pos ( deg )	Remark
2412	99.34	-	-	97.06	32.08	6.22	36.02	100	183	Peak
2412	94.77	-	-	92.49	32.08	6.22	36.02	100	183	Average
4824	44.09	-29.91	74	37.81	34.2	8.73	36.65	100	67	Peak



<b>Test Mode :</b>	802.11b	<b>Temperature :</b>	22~23°C
<b>Test Channel :</b>	06	<b>Relative Humidity :</b>	40~41%
<b>Test Engineer :</b>	Nick Su	<b>Polarization :</b>	Horizontal
<b>Remark :</b>	1. 2437 MHz is fundamental signal which can be ignored. 2. Average measurement was not performed if peak level went lower than the average limit.		

Frequency ( MHz )	Level ( dBμV/m )	Over Limit ( dB )	Limit Line ( dBμV/m )	Read Level (dBμV)	Antenna Factor ( dB )	Cable Loss ( dB )	Preamp Factor ( dB )	Ant Pos ( cm )	Table Pos ( deg )	Remark
2437	109.05	-	-	106.53	32.21	6.22	35.91	118	306	Peak
2437	104.5	-	-	101.98	32.21	6.22	35.91	118	306	Average
4874	43.29	-30.71	74	37.17	34.2	8.76	36.84	100	0	Peak
7312	45.15	-28.85	74	37.45	35.72	10.84	38.86	100	68	Peak

<b>Test Mode :</b>	802.11b	<b>Temperature :</b>	22~23°C
<b>Test Channel :</b>	06	<b>Relative Humidity :</b>	40~41%
<b>Test Engineer :</b>	Nick Su	<b>Polarization :</b>	Vertical
<b>Remark :</b>	1. 2437 MHz is fundamental signal which can be ignored. 2. Average measurement was not performed if peak level went lower than the average limit.		

Frequency ( MHz )	Level ( dBμV/m )	Over Limit ( dB )	Limit Line ( dBμV/m )	Read Level (dBμV)	Antenna Factor ( dB )	Cable Loss ( dB )	Preamp Factor ( dB )	Ant Pos ( cm )	Table Pos ( deg )	Remark
2437	99.68	-	-	97.16	32.21	6.22	35.91	100	180	Peak
2437	94.39	-	-	91.87	32.21	6.22	35.91	100	180	Average
4874	44.27	-29.73	74	38.15	34.2	8.76	36.84	103	49	Peak
7312	47.03	-26.97	74	39.33	35.72	10.84	38.86	100	68	Peak



<b>Test Mode :</b>	802.11b	<b>Temperature :</b>	22~23°C
<b>Test Channel :</b>	11	<b>Relative Humidity :</b>	40~41%
<b>Test Engineer :</b>	Nick Su	<b>Polarization :</b>	Horizontal
<b>Remark :</b>	1. 2462 MHz is fundamental signal which can be ignored. 2. Average measurement was not performed if peak level went lower than the average limit.		

Frequency ( MHz )	Level ( dBμV/m )	Over Limit ( dB )	Limit Line ( dBμV/m )	Read Level (dBμV)	Antenna Factor ( dB )	Cable Loss ( dB )	Preamp Factor ( dB )	Ant Pos ( cm )	Table Pos ( deg )	Remark
2462	105.6	-	-	102.9	32.27	6.28	35.85	117	0	Peak
2462	100.85	-	-	98.15	32.27	6.28	35.85	117	0	Average
4924	47.63	-26.37	74	41.67	34.2	8.79	37.03	105	123	Peak
7386	48.06	-25.94	74	40.6	35.76	10.89	39.19	100	68	Peak

<b>Test Mode :</b>	802.11b	<b>Temperature :</b>	22~23°C
<b>Test Channel :</b>	11	<b>Relative Humidity :</b>	40~41%
<b>Test Engineer :</b>	Nick Su	<b>Polarization :</b>	Vertical
<b>Remark :</b>	1. 2462 MHz is fundamental signal which can be ignored. 2. Average measurement was not performed if peak level went lower than the average limit.		

Frequency ( MHz )	Level ( dBμV/m )	Over Limit ( dB )	Limit Line ( dBμV/m )	Read Level (dBμV)	Antenna Factor ( dB )	Cable Loss ( dB )	Preamp Factor ( dB )	Ant Pos ( cm )	Table Pos ( deg )	Remark
2462	96.87	-	-	94.17	32.27	6.28	35.85	100	205	Peak
2462	91.92	-	-	89.22	32.27	6.28	35.85	100	205	Average
4924	48.36	-25.64	74	42.4	34.2	8.79	37.03	149	248	Peak
7386	47.4	-26.6	74	39.94	35.76	10.89	39.19	148	219	Peak





<b>Test Mode :</b>	802.11g	<b>Temperature :</b>	22~23°C
<b>Test Channel :</b>	01	<b>Relative Humidity :</b>	40~41%
<b>Test Engineer :</b>	Nick Su	<b>Polarization :</b>	Horizontal
<b>Remark :</b>	1. 2412 MHz is fundamental signal which can be ignored. 2. Average measurement was not performed if peak level went lower than the average limit.		

Frequency ( MHz )	Level ( dBμV/m )	Over Limit ( dB )	Limit Line ( dBμV/m )	Read Level (dBμV)	Antenna Factor ( dB )	Cable Loss ( dB )	Preamp Factor ( dB )	Ant Pos ( cm )	Table Pos ( deg )	Remark
2412	103.5	-	-	101.22	32.08	6.22	36.02	119	314	Peak
2412	91.38	-	-	89.1	32.08	6.22	36.02	119	314	Average
4824	43.62	-30.38	74	37.34	34.2	8.73	36.65	110	60	Peak

<b>Test Mode :</b>	802.11g	<b>Temperature :</b>	22~23°C
<b>Test Channel :</b>	01	<b>Relative Humidity :</b>	40~41%
<b>Test Engineer :</b>	Nick Su	<b>Polarization :</b>	Vertical
<b>Remark :</b>	1. 2412 MHz is fundamental signal which can be ignored. 2. Average measurement was not performed if peak level went lower than the average limit.		

Frequency ( MHz )	Level ( dBμV/m )	Over Limit ( dB )	Limit Line ( dBμV/m )	Read Level (dBμV)	Antenna Factor ( dB )	Cable Loss ( dB )	Preamp Factor ( dB )	Ant Pos ( cm )	Table Pos ( deg )	Remark
2412	94.14	-	-	91.86	32.08	6.22	36.02	102	180	Peak
2412	82.05	-	-	79.77	32.08	6.22	36.02	102	180	Average
4824	42.59	-31.41	74	36.31	34.2	8.73	36.65	100	44	Peak



<b>Test Mode :</b>	802.11g	<b>Temperature :</b>	22~23°C
<b>Test Channel :</b>	06	<b>Relative Humidity :</b>	40~41%
<b>Test Engineer :</b>	Nick Su	<b>Polarization :</b>	Horizontal
<b>Remark :</b>	1. 2437 MHz is fundamental signal which can be ignored. 2. Average measurement was not performed if peak level went lower than the average limit.		

Frequency ( MHz )	Level ( dBμV/m )	Over Limit ( dB )	Limit Line ( dBμV/m )	Read Level ( dBμV )	Antenna Factor ( dB )	Cable Loss ( dB )	Preamp Factor ( dB )	Ant Pos ( cm )	Table Pos ( deg )	Remark
2437	105.25	-	-	102.73	32.21	6.22	35.91	119	304	Peak
2437	93.25	-	-	90.73	32.21	6.22	35.91	119	304	Average
4874	46.47	-27.53	74	40.35	34.2	8.76	36.84	105	24	Peak
7312	49	-25	74	41.3	35.72	10.84	38.86	105	56	Peak

<b>Test Mode :</b>	802.11g	<b>Temperature :</b>	22~23°C
<b>Test Channel :</b>	06	<b>Relative Humidity :</b>	40~41%
<b>Test Engineer :</b>	Nick Su	<b>Polarization :</b>	Vertical
<b>Remark :</b>	1. 2437 MHz is fundamental signal which can be ignored. 2. Average measurement was not performed if peak level went lower than the average limit.		

Frequency ( MHz )	Level ( dBμV/m )	Over Limit ( dB )	Limit Line ( dBμV/m )	Read Level ( dBμV )	Antenna Factor ( dB )	Cable Loss ( dB )	Preamp Factor ( dB )	Ant Pos ( cm )	Table Pos ( deg )	Remark
2437	96.67	-	-	94.15	32.21	6.22	35.91	102	189	Peak
2437	84.55	-	-	82.03	32.21	6.22	35.91	102	189	Average
4874	46.99	-27.01	74	40.87	34.2	8.76	36.84	105	24	Peak
7312	49.37	-24.63	74	41.67	35.72	10.84	38.86	105	26	Peak



<b>Test Mode :</b>	802.11g	<b>Temperature :</b>	22~23°C
<b>Test Channel :</b>	11	<b>Relative Humidity :</b>	40~41%
<b>Test Engineer :</b>	Nick Su	<b>Polarization :</b>	Horizontal
<b>Remark :</b>	1. 2462 MHz is fundamental signal which can be ignored. 2. Average measurement was not performed if peak level went lower than the average limit.		

Frequency ( MHz )	Level ( dBμV/m )	Over Limit ( dB )	Limit Line ( dBμV/m )	Read Level (dBμV)	Antenna Factor ( dB )	Cable Loss ( dB )	Preamp Factor ( dB )	Ant Pos ( cm )	Table Pos ( deg )	Remark
66.86	25.99	-14.01	40	50.25	7.57	0.79	32.62	-	-	Peak
95.96	29.68	-13.82	43.5	50.38	10.86	1.04	32.6	-	-	Peak
140.58	32.27	-11.23	43.5	51.98	11.62	1.23	32.56	100	0	Peak
160.95	29.61	-13.89	43.5	49.43	11.29	1.44	32.55	-	-	Peak
223.03	25.62	-20.38	46	45.64	10.86	1.61	32.49	-	-	Peak
951.5	29.66	-16.34	46	36.07	21.59	3.68	31.68	-	-	Peak
2462	103.23	-	-	100.53	32.27	6.28	35.85	144	299	Peak
2462	91.84	-	-	89.14	32.27	6.28	35.85	144	299	Average
4924	42.97	-31.03	74	37.01	34.2	8.79	37.03	100	49	Peak
7386	46.7	-27.3	74	39.24	35.76	10.89	39.19	157	70	Peak



<b>Test Mode :</b>	802.11g	<b>Temperature :</b>	22~23°C
<b>Test Channel :</b>	11	<b>Relative Humidity :</b>	40~41%
<b>Test Engineer :</b>	Nick Su	<b>Polarization :</b>	Vertical
<b>Remark :</b>	1. 2462 MHz is fundamental signal which can be ignored. 2. Average measurement was not performed if peak level went lower than the average limit.		

Frequency ( MHz )	Level ( dBμV/m )	Over Limit ( dB )	Limit Line ( dBμV/m )	Read Level (dBμV)	Antenna Factor ( dB )	Cable Loss ( dB )	Preamp Factor ( dB )	Ant Pos ( cm )	Table Pos ( deg )	Remark
36.79	33.04	-6.96	40	49.09	15.77	0.79	32.61	200	0	Peak
57.16	31.24	-8.76	40	56.17	6.88	0.79	32.6	-	-	Peak
80.44	28.85	-11.15	40	51.36	9.1	1.04	32.65	-	-	Peak
95.96	28	-15.5	43.5	48.7	10.86	1.04	32.6	-	-	Peak
139.61	23.77	-19.73	43.5	43.48	11.62	1.23	32.56	-	-	Peak
951.5	29.01	-16.99	46	35.42	21.59	3.68	31.68	-	-	Peak
2462	94.41	-	-	91.71	32.27	6.28	35.85	124	161	Peak
2462	83.38	-	-	80.68	32.27	6.28	35.85	124	161	Average
4924	44.92	-29.08	74	38.96	34.2	8.79	37.03	100	64	Peak
7386	46.12	-27.88	74	38.66	35.76	10.89	39.19	100	94	Peak



<b>Test Mode :</b>	2.4GHz 802.11n HT20	<b>Temperature :</b>	22~23°C
<b>Test Channel :</b>	01	<b>Relative Humidity :</b>	40~41%
<b>Test Engineer :</b>	Nick Su	<b>Polarization :</b>	Horizontal
<b>Remark :</b>	1. 2412 MHz is fundamental signal which can be ignored. 2. Average measurement was not performed if peak level went lower than the average limit.		

Frequency ( MHz )	Level ( dBμV/m )	Over Limit ( dB )	Limit Line ( dBμV/m )	Read Level (dBμV)	Antenna Factor ( dB )	Cable Loss ( dB )	Preamp Factor ( dB )	Ant Pos ( cm )	Table Pos ( deg )	Remark
2412	97.19	-	-	94.91	32.08	6.22	36.02	100	331	Peak
2412	86.15	-	-	83.87	32.08	6.22	36.02	100	331	Average
4824	46.06	-27.94	74	39.78	34.2	8.73	36.65	105	264	Peak

<b>Test Mode :</b>	2.4GHz 802.11n HT20	<b>Temperature :</b>	22~23°C
<b>Test Channel :</b>	01	<b>Relative Humidity :</b>	40~41%
<b>Test Engineer :</b>	Nick Su	<b>Polarization :</b>	Vertical
<b>Remark :</b>	1. 2412 MHz is fundamental signal which can be ignored. 2. Average measurement was not performed if peak level went lower than the average limit.		

Frequency ( MHz )	Level ( dBμV/m )	Over Limit ( dB )	Limit Line ( dBμV/m )	Read Level (dBμV)	Antenna Factor ( dB )	Cable Loss ( dB )	Preamp Factor ( dB )	Ant Pos ( cm )	Table Pos ( deg )	Remark
2412	101.36	-	-	99.08	32.08	6.22	36.02	108	238	Peak
2412	88.34	-	-	86.06	32.08	6.22	36.02	108	238	Average
4824	46.45	-27.55	74	40.17	34.2	8.73	36.65	162	14	Peak



<b>Test Mode :</b>	2.4GHz 802.11n HT20	<b>Temperature :</b>	22~23°C
<b>Test Channel :</b>	06	<b>Relative Humidity :</b>	40~41%
<b>Test Engineer :</b>	Nick Su	<b>Polarization :</b>	Horizontal
<b>Remark :</b>	1. 2437 MHz is fundamental signal which can be ignored. 2. Average measurement was not performed if peak level went lower than the average limit.		

Frequency ( MHz )	Level ( dBμV/m )	Over Limit ( dB )	Limit Line ( dBμV/m )	Read Level (dBμV)	Antenna Factor ( dB )	Cable Loss ( dB )	Preamp Factor ( dB )	Ant Pos ( cm )	Table Pos ( deg )	Remark
2437	98.65	-	-	96.13	32.21	6.22	35.91	119	335	Peak
2437	87.16	-	-	84.64	32.21	6.22	35.91	119	335	Average
4874	45.56	-28.44	74	39.44	34.2	8.76	36.84	115	24	Peak
7312	47.59	-26.41	74	39.89	35.72	10.84	38.86	159	206	Peak

<b>Test Mode :</b>	2.4GHz 802.11n HT20	<b>Temperature :</b>	22~23°C
<b>Test Channel :</b>	06	<b>Relative Humidity :</b>	40~41%
<b>Test Engineer :</b>	Nick Su	<b>Polarization :</b>	Vertical
<b>Remark :</b>	1. 2437 MHz is fundamental signal which can be ignored. 2. Average measurement was not performed if peak level went lower than the average limit.		

Frequency ( MHz )	Level ( dBμV/m )	Over Limit ( dB )	Limit Line ( dBμV/m )	Read Level (dBμV)	Antenna Factor ( dB )	Cable Loss ( dB )	Preamp Factor ( dB )	Ant Pos ( cm )	Table Pos ( deg )	Remark
2437	102.13	-	-	99.61	32.21	6.22	35.91	122	296	Peak
2437	89.36	-	-	86.84	32.21	6.22	35.91	122	296	Average
4874	46.53	-27.47	74	40.41	34.2	8.76	36.84	147	252	Peak
7312	49.42	-24.58	74	41.72	35.72	10.84	38.86	156	332	Peak



<b>Test Mode :</b>	2.4GHz 802.11n HT20	<b>Temperature :</b>	22~23°C
<b>Test Channel :</b>	11	<b>Relative Humidity :</b>	40~41%
<b>Test Engineer :</b>	Nick Su	<b>Polarization :</b>	Horizontal
<b>Remark :</b>	1. 2462 MHz is fundamental signal which can be ignored. 2. Average measurement was not performed if peak level went lower than the average limit.		

Frequency ( MHz )	Level ( dBμV/m )	Over Limit ( dB )	Limit Line ( dBμV/m )	Read Level (dBμV)	Antenna Factor ( dB )	Cable Loss ( dB )	Preamp Factor ( dB )	Ant Pos ( cm )	Table Pos ( deg )	Remark
2462	95.43	-	-	92.73	32.27	6.28	35.85	100	36	Peak
2462	83.96	-	-	81.26	32.27	6.28	35.85	100	36	Average
4924	46.09	-27.91	74	40.13	34.2	8.79	37.03	100	0	Peak
7386	47.17	-26.83	74	39.71	35.76	10.89	39.19	112	302	Peak

<b>Test Mode :</b>	2.4GHz 802.11n HT20	<b>Temperature :</b>	22~23°C
<b>Test Channel :</b>	11	<b>Relative Humidity :</b>	40~41%
<b>Test Engineer :</b>	Nick Su	<b>Polarization :</b>	Vertical
<b>Remark :</b>	1. 2462 MHz is fundamental signal which can be ignored. 2. Average measurement was not performed if peak level went lower than the average limit.		

Frequency ( MHz )	Level ( dBμV/m )	Over Limit ( dB )	Limit Line ( dBμV/m )	Read Level (dBμV)	Antenna Factor ( dB )	Cable Loss ( dB )	Preamp Factor ( dB )	Ant Pos ( cm )	Table Pos ( deg )	Remark
2462	100.72	-	-	98.02	32.27	6.28	35.85	105	236	Peak
2462	89.64	-	-	86.94	32.27	6.28	35.85	105	236	Average
4924	45.87	-28.13	74	39.91	34.2	8.79	37.03	105	64	Peak
7386	49.72	-24.28	74	42.26	35.76	10.89	39.19	154	306	Peak



### 3.6 AC Conducted Emission Measurement

#### 3.6.1 Limit of AC Conducted Emission

For equipment that is designed to be connected to the public utility (AC) power line, the radio frequency voltage that is conducted back onto the AC power line on any frequency or frequencies within the band 150 kHz to 30 MHz shall not exceed the limits in the following table.

Frequency of Emission (MHz)	Conducted Limit (dB $\mu$ V)	
	Quasi-Peak	Average
0.15-0.5	66 to 56*	56 to 46*
0.5-5	56	46
5-30	60	50

\*Decreases with the logarithm of the frequency.

#### 3.6.2 Measuring Instruments

The measuring equipment is listed in the section 4 of this test report.

#### 3.6.3 Test Procedures

1. The EUT was placed 0.4 meter from the conducting wall of the shielding room, and it was kept at least 80 centimeters from any other grounded conducting surface.
2. Connect EUT to the power mains through a line impedance stabilization network (LISN).
3. All the support units are connecting to the other LISN.
4. The LISN provides 50 ohm coupling impedance for the measuring instrument.
5. The FCC states that a 50 ohm, 50 microhenry LISN should be used.
6. Both sides of AC line were checked for maximum conducted interference.
7. The frequency range from 150 kHz to 30 MHz was searched.
8. Set the test-receiver system to Peak Detect Function and specified bandwidth (IF bandwidth = 9kHz) with Maximum Hold Mode.



### 3.6.4 Test Setup

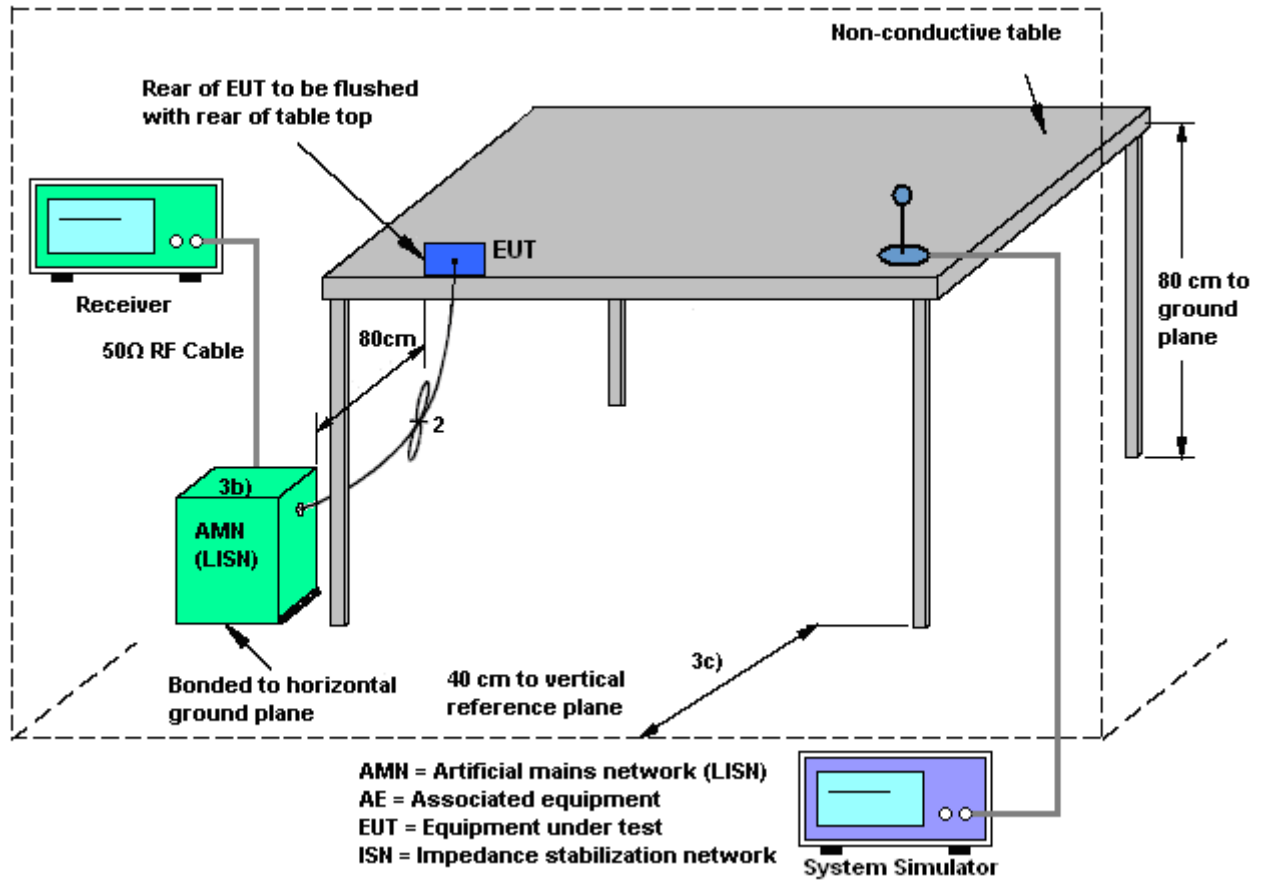



3.6.5 Test Result of AC Conducted Emission

Test Mode :	Mode 1	Temperature :	22~24°C
Test Engineer :	Eligah Wang	Relative Humidity :	38~40%
Test Voltage :	120Vac / 60Hz	Phase :	Line
Function Type :	GSM850 Idle + Bluetooth Link + WLAN Link + USB Cable (Charging from Adapter) + Earphone		

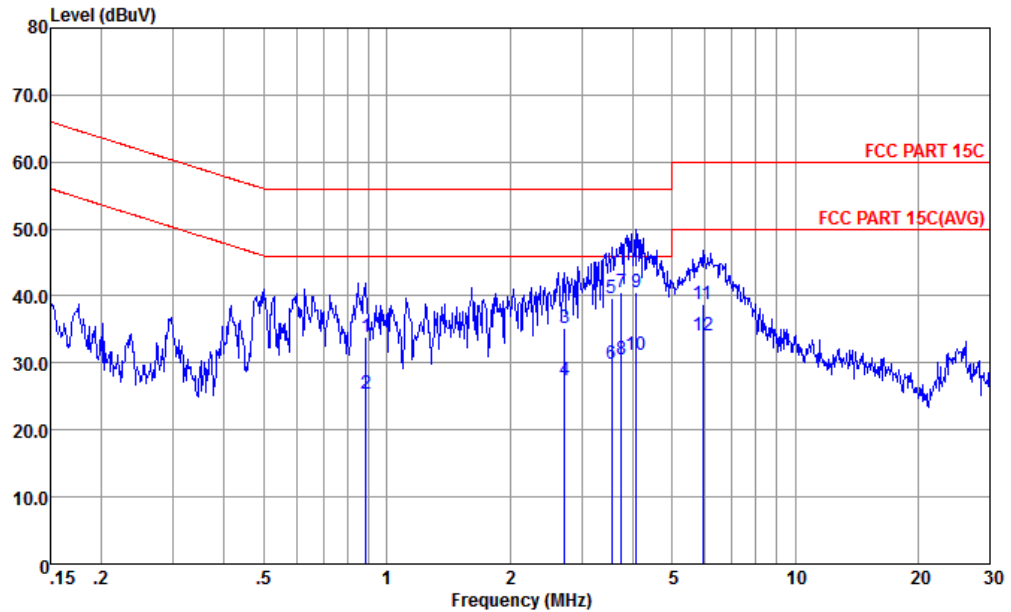

Site : CO01-KS  
 Condition : FCC PART 15C LISN-L20140306 LINE

mode : Mode 1

	Freq	Level	Over Limit	Limit Line	Read Level	LISN Factor	Cable Loss	Remark
	MHz	dBuV	dB	dBuV	dBuV	dB	dB	
1	0.89	33.87	-22.13	56.00	23.09	0.13	10.65	QP
2	0.89	25.37	-20.63	46.00	14.59	0.13	10.65	Average
3	2.72	35.17	-20.83	56.00	24.30	0.12	10.75	QP
4	2.72	27.47	-18.53	46.00	16.60	0.12	10.75	Average
5	3.55	39.59	-16.41	56.00	28.60	0.17	10.82	QP
6	3.55	29.89	-16.11	46.00	18.90	0.17	10.82	Average
7	3.76	40.60	-15.40	56.00	29.60	0.18	10.82	QP
8	3.76	30.60	-15.40	46.00	19.60	0.18	10.82	Average
9	4.09	40.62	-15.38	56.00	29.60	0.19	10.83	QP
10 *	4.09	31.12	-14.88	46.00	20.10	0.19	10.83	Average
11	5.93	38.68	-21.32	60.00	27.60	0.20	10.88	QP
12	5.93	34.18	-15.82	50.00	23.10	0.20	10.88	Average



Test Mode :	Mode 1	Temperature :	22~24°C
Test Engineer :	Eligah Wang	Relative Humidity :	38~40%
Test Voltage :	120Vac / 60Hz	Phase :	Neutral
Function Type :	GSM850 Idle + Bluetooth Link + WLAN Link + USB Cable (Charging from Adapter) + Earphone		

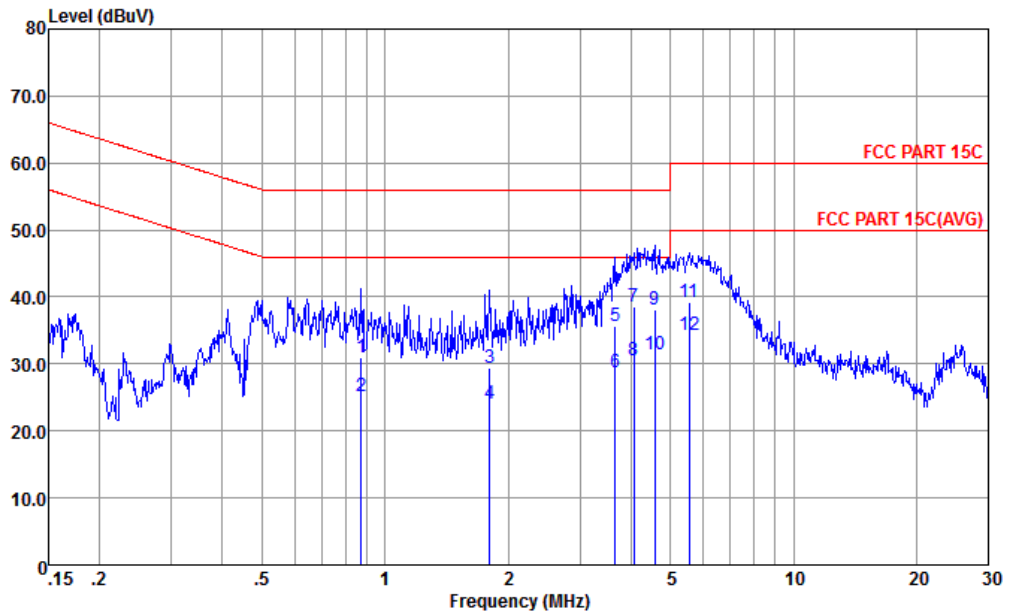

Site : CO01-KS  
Condition : FCC PART 15C LISN-N20140306 NEUTRAL

mode : Mode 1

	Freq	Level	Over Limit	Limit Line	Read Level	LISN Factor	Cable Loss	Remark
	MHz	dBuV	dB	dBuV	dBuV	dB	dB	
1	0.88	30.88	-25.12	56.00	20.10	0.13	10.65	QP
2	0.88	25.08	-20.92	46.00	14.30	0.13	10.65	Average
3	1.80	29.40	-26.60	56.00	18.60	0.10	10.70	QP
4	1.80	24.10	-21.90	46.00	13.30	0.10	10.70	Average
5	3.66	35.60	-20.40	56.00	24.60	0.18	10.82	QP
6	3.66	28.80	-17.20	46.00	17.80	0.18	10.82	Average
7	4.07	38.62	-17.38	56.00	27.60	0.19	10.83	QP
8	4.07	30.62	-15.38	46.00	19.60	0.19	10.83	Average
9	4.57	38.14	-17.86	56.00	27.11	0.19	10.84	QP
10 *	4.57	31.34	-14.66	46.00	20.31	0.19	10.84	Average
11	5.56	39.16	-20.84	60.00	28.10	0.20	10.86	QP
12	5.56	34.36	-15.64	50.00	23.30	0.20	10.86	Average



## **3.7 Antenna Requirements**

### **3.7.1 Standard Applicable**

If directional gain of transmitting antennas is greater than 6dBi, the power shall be reduced by the same level in dB comparing to gain minus 6dBi. For the fixed point-to-point operation, the power shall be reduced by one dB for every 3 dB that the directional gain of the antenna exceeds 6 dBi. The use of a permanently attached antenna or of an antenna that uses a unique coupling to the intentional radiator shall be considered sufficient to comply with the FCC rule.

### **3.7.2 Antenna Anti-Replacement Construction**

An embedded-in antenna design is used.

### **3.7.3 Antenna Gain**

The antenna peak gain of EUT is less than 6 dBi. Therefore, it is not necessary to reduce maximum peak output power limit.



## 4 List of Measuring Equipment

Instrument	Manufacturer	Model No.	Serial No.	Characteristics	Calibration Date	Test Date	Due Date	Remark
Spectrum Analyzer	R&S	FSP40	100319	9kHz~40GHz	Oct. 28, 2014	Nov. 10, 2014	Oct. 27, 2015	Conducted (TH01-KS)
Pulse Power Sensor	Anritsu	MA2411B	0917070	30MHz~40GHz	Feb. 27, 2014	Nov. 10, 2014	Feb. 26, 2015	Conducted (TH01-KS)
Power Meter	Anritsu	ML2495A	1005002	50MHz Bandwidth	Feb. 27, 2014	Nov. 10, 2014	Feb. 26, 2015	Conducted (TH01-KS)
EMI Test Receiver	R&S	ESCI	100534	9kHz~3GHz	Oct. 25, 2014	Nov. 20, 2014	Oct. 24, 2015	Radiation (03CH01-KS)
Spectrum Analyzer	R&S	FSP30	101399	9kHz~30GHz	May 04, 2014	Nov. 20, 2014	May 03, 2015	Radiation (03CH01-KS)
Loop Antenna	R&S	HFH2-Z2	100321	9kHz~30MHz	Nov. 13, 2014	Nov. 20, 2014	Nov. 12, 2015	Radiation (03CH01-KS)
Bilog Antenna	SCHAFFNER	CBL6112D	23182	25MHz~2GHz	Jan. 08, 2014	Nov. 20, 2014	Jan. 07, 2015	Radiation (03CH01-KS)
Double Ridge Horn Antenna	ETS-Lindgren	3117	75957	1GHz~18GHz	Nov. 08, 2014	Nov. 20, 2014	Nov. 07, 2015	Radiation (03CH01-KS)
Active Horn Antenna	com-power	AHA-118	701030	1GHz~18GHz	Nov. 08, 2014	Nov. 20, 2014	Nov. 07, 2015	Radiation (03CH01-KS)
SHF-EHF Horn	Schwarzbeck	BBHA 9170	BBHA1702 49	15GHz~40GHz	Mar. 10, 2014	Nov. 20, 2014	Mar. 09, 2015	Radiation (03CH01-KS)
Amplifier	com-power	PA-103A	161073	1MHz~1GHz	May 04, 2014	Nov. 20, 2014	May 03, 2015	Radiation (03CH01-KS)
Amplifier	Agilent	8449B	3008A023 71	1GHz~26.5GHz	Oct. 28, 2014	Nov. 20, 2014	Oct. 27, 2015	Radiation (03CH01-KS)
AC Power Source	Chroma	61601	F1040900 04	N/A	NCR	Nov. 20, 2014	NCR	Radiation (03CH01-KS)
Turn Table	MF	MF7802	N/A	0~360 degree	NCR	Nov. 20, 2014	NCR	Radiation (03CH01-KS)
Antenna Mast	MF	MF7802	N/A	1 m~4 m	NCR	Nov. 20, 2014	NCR	Radiation (03CH01-KS)
EMI Receiver	R&S	ESCI7	100768	9kHz~7GHz;	May 04, 2014	Nov. 10, 2014	May 03, 2015	Conduction (CO01-KS)
AC LISN	MessTec	AN3016	060103	9kHz~30MHz	Oct. 25, 2014	Nov. 10, 2014	Oct. 24, 2015	Conduction (CO01-KS)
AC LISN (for auxiliary equipment)	MessTec	AN3016	060105	9kHz~30MHz	Oct. 25, 2014	Nov. 10, 2014	Oct. 24, 2015	Conduction (CO01-KS)
AC Power Source	Chroma	61602	ABP00000 0811	AC 0V~300V, 45Hz~1000Hz	Oct. 25, 2014	Nov. 10, 2014	Oct. 24, 2015	Conduction (CO01-KS)



## 5 Uncertainty of Evaluation

### Uncertainty of Conducted Emission Measurement (150kHz ~ 30MHz)

Measuring Uncertainty for a Level of Confidence of 95% ( $U = 2Uc(y)$ )	2.3
---	-----

### Uncertainty of Radiated Emission Measurement (30 MHz ~ 1000 MHz)

Measuring Uncertainty for a Level of Confidence of 95% ( $U = 2Uc(y)$ )	2.5
---	-----