



# FCC RF Test Report

**APPLICANT** : Lenovo Mobile Communication  
Technology Ltd.  
**EQUIPMENT** : Mobile Cellular Phone  
**BRAND NAME** : Lenovo  
**MODEL NAME** : Lenovo K53b36, Lenovo K53b37  
**FCC ID** : YCNK53B3  
**STANDARD** : FCC Part 15 Subpart C §15.247  
**CLASSIFICATION** : (DTS) Digital Transmission System

The product was received on Jun. 20, 2016 and testing was completed on Sep. 03, 2016. We, SPORTON INTERNATIONAL (KUNSHAN) INC., would like to declare that the tested sample has been evaluated in accordance with the test procedures and has been in compliance with the applicable technical standards.

The test results in this report apply exclusively to the tested model / sample. Without written approval of SPORTON INTERNATIONAL (KUNSHAN) INC., the test report shall not be reproduced except in full.

Prepared by: James Huang / Manager



Approved by: Jones Tsai / Manager

**SPORTON INTERNATIONAL (KUNSHAN) INC.**

**No. 3-2, PingXiang Road, Kunshan, Jiangsu Province, P. R. China**



# TABLE OF CONTENTS

**SUMMARY OF TEST RESULT ..... 4**

**1 GENERAL DESCRIPTION ..... 5**

1.1 Applicant ..... 5

1.2 Manufacturer ..... 5

1.3 Product Feature of Equipment Under Test ..... 5

1.4 Product Specification of Equipment Under Test ..... 6

1.5 Specification of Accessory ..... 6

1.6 Modification of EUT ..... 6

1.7 Testing Location ..... 7

1.8 Applicable Standards ..... 7

**2 TEST CONFIGURATION OF EQUIPMENT UNDER TEST ..... 8**

2.1 Descriptions of Test Mode ..... 8

2.2 Test Mode ..... 9

2.3 Connection Diagram of Test System ..... 10

2.4 Support Unit used in test configuration and system ..... 11

2.5 EUT Operation Test Setup ..... 11

2.6 Measurement Results Explanation Example ..... 12

**3 TEST RESULT ..... 13**

3.1 6dB Bandwidth Measurement ..... 13

3.2 Peak Output Power Measurement ..... 18

3.3 Power Spectral Density Measurement ..... 19

3.4 Conducted Band Edges and Spurious Emission Measurement ..... 28

3.5 Radiated Band Edges and Spurious Emission Measurement ..... 45

3.6 AC Conducted Emission Measurement ..... 49

3.7 Antenna Requirements ..... 53

**4 LIST OF MEASURING EQUIPMENT ..... 54**

**5 UNCERTAINTY OF EVALUATION ..... 56**

**APPENDIX A. CONDUCTED TEST RESULTS**

**APPENDIX B. RADIATED TEST RESULTS**

**APPENDIX C. DUTY CYCLE PLOTS**

**APPENDIX D. SETUP PHOTOGRAPHS**





### SUMMARY OF TEST RESULT

Report Section	FCC Rule	Description	Limit	Result	Remark
3.1	15.247(a)(2)	6dB Bandwidth	$\geq 0.5\text{MHz}$	Pass	-
3.2	15.247(b)(3)	Peak Output Power	$\leq 30\text{dBm}$	Pass	-
3.3	15.247(e)	Power Spectral Density	$\leq 8\text{dBm}/3\text{kHz}$	Pass	-
3.4	15.247(d)	Conducted Band Edges and Spurious Emission	$\leq 20\text{dBc}$	Pass	-
3.5	15.247(d)	Radiated Band Edges and Spurious Emission	15.209(a) & 15.247(d)	Pass	Under limit 11.48 dB at 2483.500 MHz
3.6	15.207	AC Conducted Emission	15.207(a)	Pass	Under limit 4.56 dB at 18.135 MHz
3.7	15.203 & 15.247(b)	Antenna Requirement	N/A	Pass	-



# 1 General Description

## 1.1 Applicant

**Lenovo Mobile Communication Technology Ltd.**

No.999, Qishan North 2nd Road, Information & Optoelectronics Park, Torch Hi-tech Industry Development Zone, Xiamen, P.R.China

## 1.2 Manufacturer

**Motorola Mobility LLC**

222 W. Merchandise Mart Plaza, Chicago IL 60654 USA

## 1.3 Product Feature of Equipment Under Test

Product Feature	
<b>Equipment</b>	Mobile Cellular Phone
<b>Brand Name</b>	Lenovo
<b>Model Name</b>	Lenovo K53b36, Lenovo K53b37
<b>FCC ID</b>	YCNK53B3
<b>EUT supports Radios application</b>	GSM/GPRS/EGPRS/WCDMA/HSPA/DC-HSDPA/ HSPA+(16QAM uplink is not supported)/LTE/ WLAN2.4GHz 802.11b/g/n HT20/ Bluetooth v3.0+EDR/Bluetooth v4.0 LE/ Bluetooth v4.2 LE
<b>IMEI Code</b>	Conducted: Sample 1: 861901030021452/861901030021460 Conduction: Sample 1: 861901030024332/861901030024340 Sample 2: 861902030000132 Radiation: Sample 1: 861901030022278/861901030022286
<b>HW Version</b>	82939_1_13
<b>SW Version</b>	K53_S016_160729_ROW
<b>EUT Stage</b>	Identical Prototype

**Remark:**

1. The above EUT's information was declared by manufacturer. Please refer to the specifications or user's manual for more detailed description.
2. There are two different types of EUT. They are single SIM card mobile (Model Name: Lenovo K53b37) and dual SIM card mobile (Model Name: Lenovo K53b36). The others are the same including circuit design, PCB board, structure and all components.

### 1.4 Product Specification of Equipment Under Test

Standards-related Product Specification	
<b>Tx/Rx Frequency Range</b>	2402 MHz ~ 2480 MHz
<b>Number of Channels</b>	40
<b>Carrier Frequency of Each Channel</b>	40 Channel(37 hopping + 3 advertising channel)
<b>Maximum Output Power to Antenna</b>	Bluetooth 4.0 LE: 0.42 dBm (0.0011 W) Bluetooth 4.2 LE: 0.16 dBm (0.0010 W)
<b>Antenna Type / Gain</b>	LDS Antenna with gain -4.93 dBi
<b>Type of Modulation</b>	Bluetooth LE : GFSK

### 1.5 Specification of Accessory

Specification of Accessory			
AC Adapter 1	<b>Brand Name</b>	Lenovo (Acbel)	<b>Model Name</b> C-P35
	<b>Power Rating</b>	I/P: 100-240Vac, 300mA, O/P: 5.2Vdc, 2000mA	
AC Adapter 2	<b>Brand Name</b>	Lenovo (Huntkey)	<b>Model Name</b> C-P35
	<b>Power Rating</b>	I/P: 100-240Vac, 500mA, O/P: 5.2Vdc, 2000mA	
Battery	<b>Brand Name</b>	Lenovo (SCUD)	<b>Model Name</b> BL270
	<b>Power Rating</b>	3.85Vdc, 4000mAh	
Earphone	<b>Brand Name</b>	Lenovo (Cosonic)	<b>Model Name</b> LS-118M
	<b>Signal Line Type</b>	1.1 meter, non-shielded cable, without ferrite core	
USB Cable 1	<b>Brand Name</b>	Lenovo(Starw)	<b>Model Name</b> XJ-007070
	<b>Signal Line Type</b>	1.0 meter, non-shielded cable, without ferrite core	
USB Cable 2	<b>Brand Name</b>	Lenovo(Saibao)	<b>Model Name</b> SWT-A053A
	<b>Signal Line Type</b>	1.0 meter, non-shielded cable, without ferrite core	
LCD Panel	<b>Brand Name</b>	Tianma Micro-electronics	<b>Model Name</b> TL055VDXP64-00
Camera_ Front	<b>Brand Name</b>	Q-Tech	<b>Model Name</b> FX219BQS
Camera_ Rear	<b>Brand Name</b>	Sunny	<b>Model Name</b> A16S05J-200
CTP Module	<b>Brand Name</b>	O-FILM	<b>Model Name</b> Black: MCF-055-2594 White: MCF-055-2594 Golden: MCF-055-2594

### 1.6 Modification of EUT

No modifications are made to the EUT during all test items.



### 1.7 Testing Location

<b>Test Site</b>	SPORTON INTERNATIONAL (KUNSHAN) INC.			
<b>Test Site Location</b>	No. 3-2, PingXiang Road, Kunshan, Jiangsu Province, P. R. China TEL: +86-0512-5790-0158 FAX: +86-0512-5790-0958			
<b>Test Site No.</b>	<b>Sporton Site No.</b>			<b>FCC Registration No.</b>
	TH01-KS	CO01-KS	03CH03-KS	306251

<b>Test Site</b>	SPORTON INTERNATIONAL (KUNSHAN) INC.			
<b>Test Site Location</b>	No. 3-2, PingXiang Road, Kunshan, Jiangsu Province, P. R. China TEL: +86-0512-5790-0158 FAX: +86-0512-5790-0958			
<b>Test Site No.</b>	<b>Sporton Site No.</b>			<b>FCC Registration No.</b>
	03CH02-KS			418269

Note: The test site complies with ANSI C63.4 2014 requirement.

### 1.8 Applicable Standards

According to the specifications of the manufacturer, the EUT must comply with the requirements of the following standards:

- FCC Part 15 Subpart C §15.247
- FCC KDB Publication No. 558074 D01 DTS Meas. Guidance v03r05
- ANSI C63.10-2013

**Remark:**

1. All test items were verified and recorded according to the standards and without any deviation during the test.
2. This EUT has also been tested and complied with the requirements of FCC Part 15, Subpart B, recorded in a separate test report.



## 2 Test Configuration of Equipment Under Test

### 2.1 Descriptions of Test Mode

The RF output power was recorded in the following table:

Channel	Frequency	Bluetooth LE RF Output Power	
		Data Rate / Modulation	
		GFSK	
		v4.0	v4.2
Ch00	2402MHz	-0.42 dBm	-1.01 dBm
Ch39	2441MHz	<b>0.42 dBm</b>	-0.08 dBm
Ch78	2480MHz	0.10 dBm	<b>0.16 dBm</b>

- a. The EUT has been associated with peripherals and configuration operated in a manner tended to maximize its emission characteristics in a typical application. Frequency range investigated: conduction (150 kHz to 30 MHz), radiation (9 kHz to the 10th harmonic of the highest fundamental frequency or to 40 GHz, whichever is lower). Pre-scanned tests, X, Y, Z in three orthogonal panels to determine the final configuration (Z plane as worst plane) from all possible combinations.
  
- b. AC power line Conducted Emission was tested under maximum output power.





## 2.2 Test Mode

The following summary table is showing all test modes to demonstrate in compliance with the standard.

Summary table of Test Cases	
Test Item	Data Rate / Modulation
	Bluetooth – LE / GFSK
Conducted TCs	Mode 1: Bluetooth Tx CH00_2402 MHz_1Mbps Mode 2: Bluetooth Tx CH19_2440 MHz_1Mbps Mode 3: Bluetooth Tx CH39_2480 MHz_1Mbps
Radiated TCs	Mode 1: Bluetooth Tx CH00_2402 MHz_1Mbps Mode 2: Bluetooth Tx CH19_2440 MHz_1Mbps Mode 3: Bluetooth Tx CH39_2480 MHz_1Mbps
AC Conducted Emission	Mode 1 :GSM850 Idle + Bluetooth Link + WLAN Link + Earphone + USB Cable 1(Charging from Adapter 1) for Sample 1 Mode 2 :GSM850 Idle + Bluetooth Link + WLAN Link + Earphone + USB Cable 2(Charging from Adapter 2) for Sample 2
<b>Remark:</b> The worst case of conducted emission is mode 2; only the test data of it was reported.	

## 2.3 Connection Diagram of Test System

<Bluetooth v4.0 LE Tx Mode>

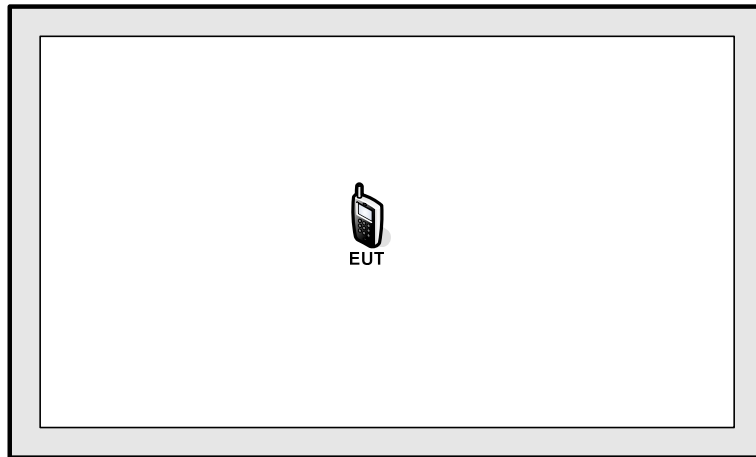

< Bluetooth v4.2 LE Tx Mode >

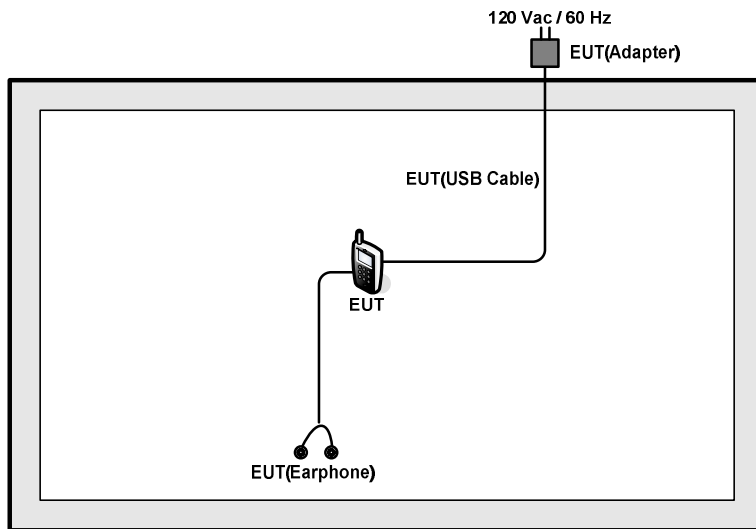

<AC Conducted Emission Mode>

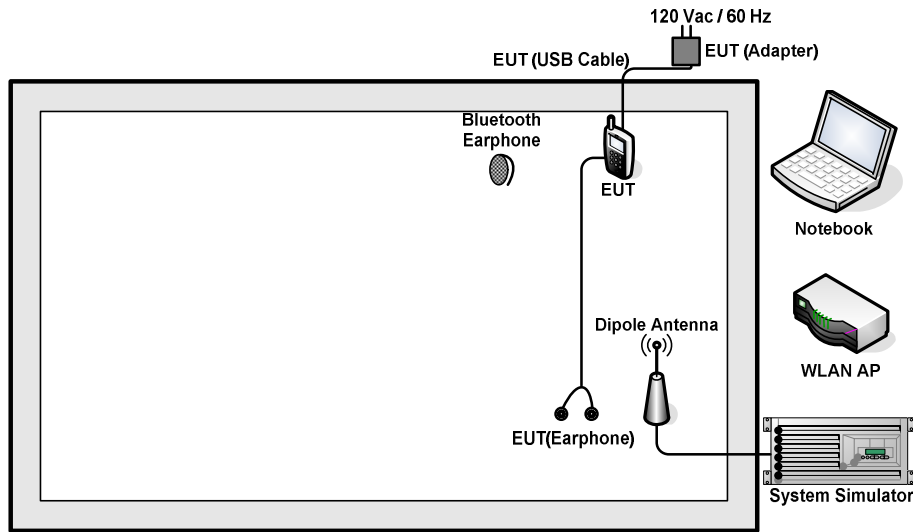

## 2.4 Support Unit used in test configuration and system

Item	Equipment	Trade Name	Model Name	FCC ID	Data Cable	Power Cord
1.	System Simulator	Anritus	MT8820C	N/A	N/A	Unshielded, 1.8 m
2.	WLAN AP	LINKSYS	WRT600N	Q87-WRT600NV11	N/A	Unshielded, 1.8 m
3.	Notebook	Lenovo	G480	N/A	N/A	AC I/P: Unshielded, 1.8 m DC O/P: Shielded, 1.8 m
4.	Bluetooth Earphone	Lenovo	LBH308	N/A	N/A	N/A

## 2.5 EUT Operation Test Setup

For Bluetooth LE function, the engineering test program was provided and enabled to make EUT continuous transmit/receive.

For AC power line conducted emissions, the EUT was set to connect with the WLAN AP under large package sizes transmission.



## 2.6 Measurement Results Explanation Example

For all conducted test items:

The offset level is set in the spectrum analyzer to compensate the RF cable loss between EUT conducted output port and spectrum analyzer. With the offset compensation, the spectrum analyzer reading level is exactly the EUT RF output level.

Example:

The spectrum analyzer offset is derived from RF cable loss.

*Offset = RF cable loss.*

Following shows an offset computation example with cable loss 5.5 dB.

$$\begin{aligned} \text{Offset(dB)} &= \text{RF cable loss(dB)}. \\ &= 5.5 \text{ (dB)} \end{aligned}$$

### 3 Test Result

#### 3.1 6dB Bandwidth Measurement

##### 3.1.1 Limit of 6dB Bandwidth

The minimum 6 dB bandwidth shall be at least 500 kHz.

##### 3.1.2 Measuring Instruments

The section 4.0 of List of Measuring Equipment of this test report is used for test.

##### 3.1.3 Test Procedures

1. The testing follows FCC KDB Publication No. 558074 D01 DTS Meas. Guidance v03r05.
2. The RF output of EUT was connected to the spectrum analyzer by RF cable and attenuator. The path loss was compensated to the results for each measurement.
3. Set to the maximum power setting and enable the EUT transmit continuously.
4. Make the measurement with the spectrum analyzer's resolution bandwidth (RBW) = 100 kHz. Set the Video bandwidth (VBW) = 300 kHz. In order to make an accurate measurement. The 6 dB bandwidth must be greater than 500 kHz.
5. Measure and record the results in the test report.

##### 3.1.4 Test Setup





### 3.1.5 Test Result of 6dB Bandwidth

Test data refer to Appendix A.

Bluetooth v4.0 LE

6 dB Bandwidth Plot on Channel 00

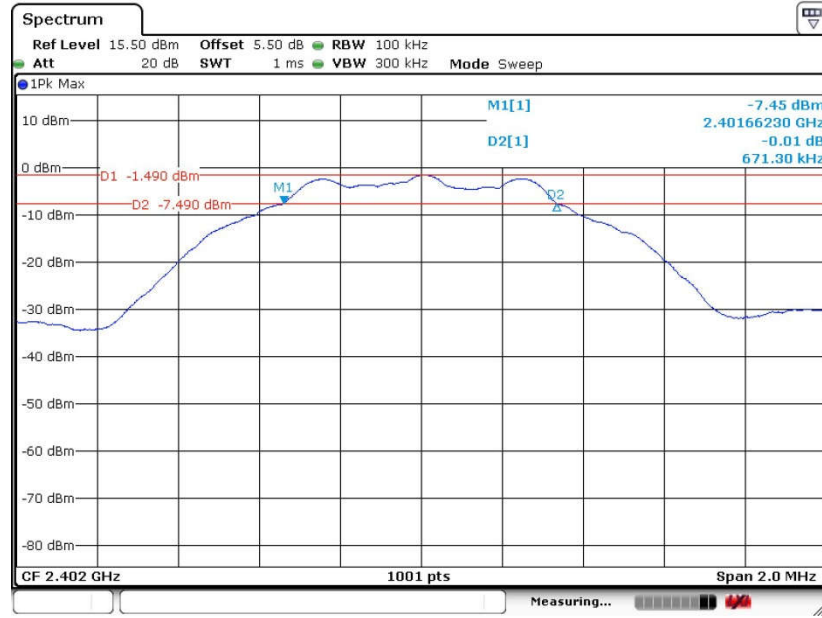

Date: 17.AUG.2016 00:08:55



6 dB Bandwidth Plot on Channel 19

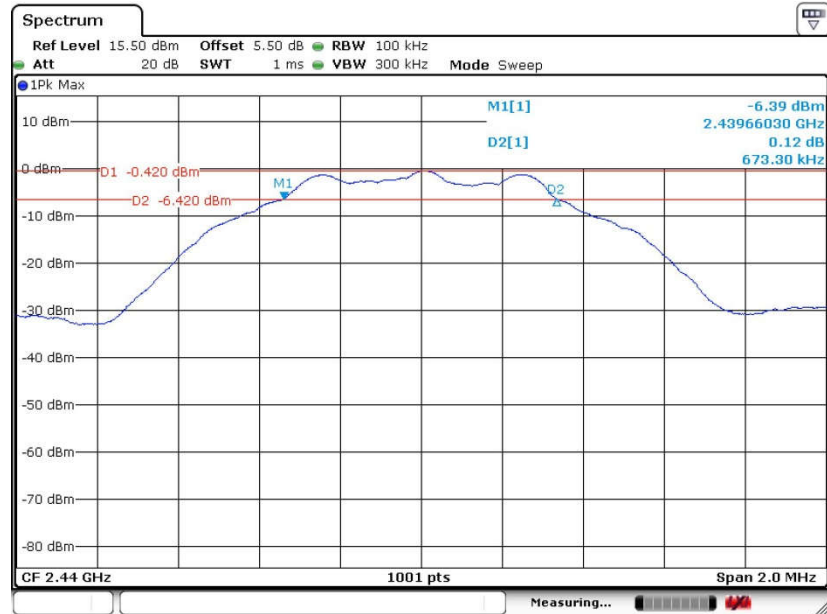

6 dB Bandwidth Plot on Channel 39

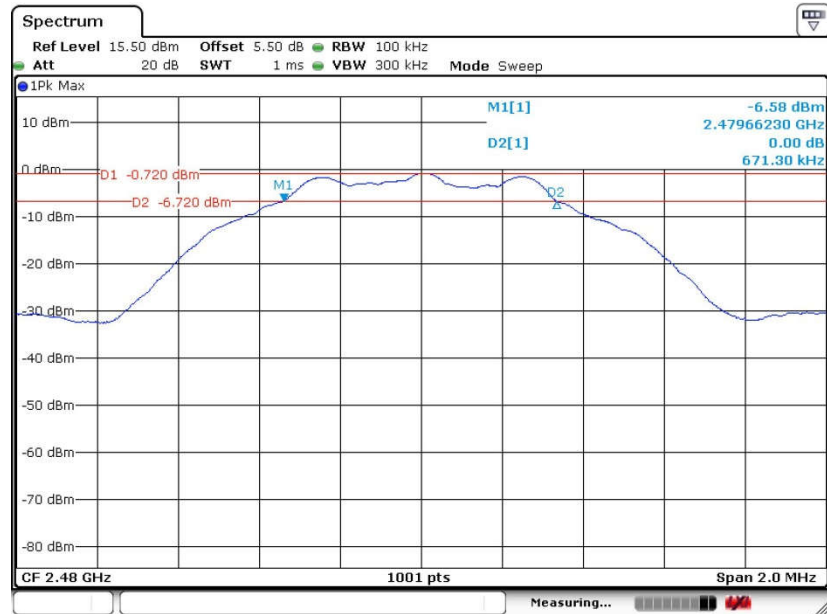



Bluetooth v4.2 LE

6 dB Bandwidth Plot on Channel 00

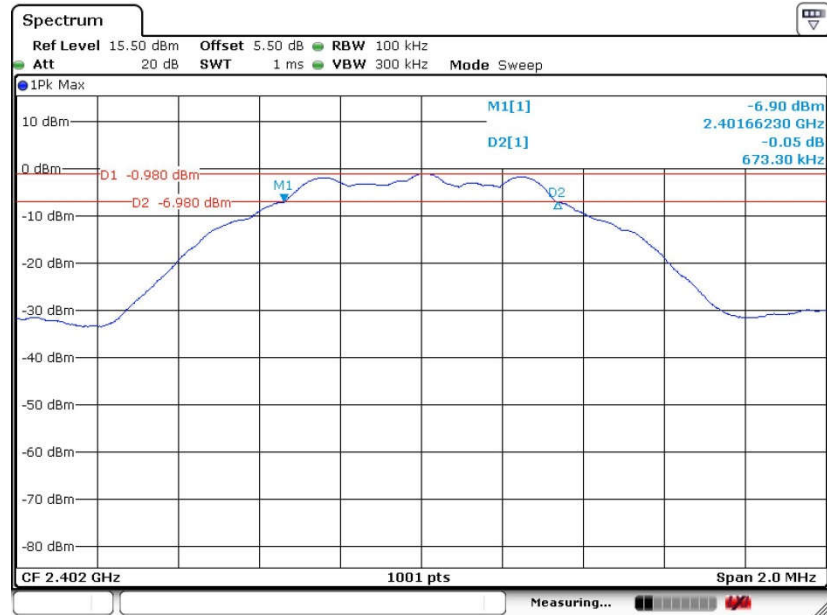

Date: 3.SEP.2016 01:06:15





### 6 dB Bandwidth Plot on Channel 19

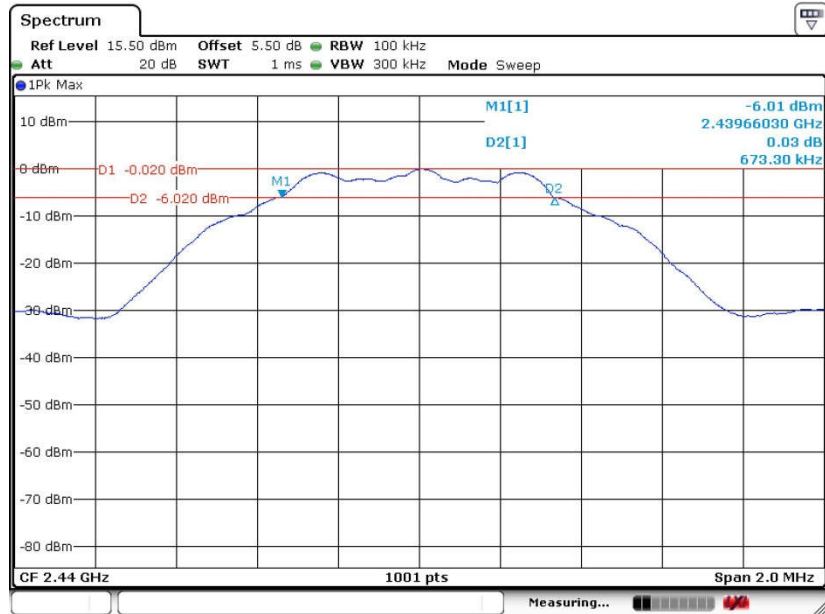

Date: 3.SEP.2016 01:11:41

### 6 dB Bandwidth Plot on Channel 39

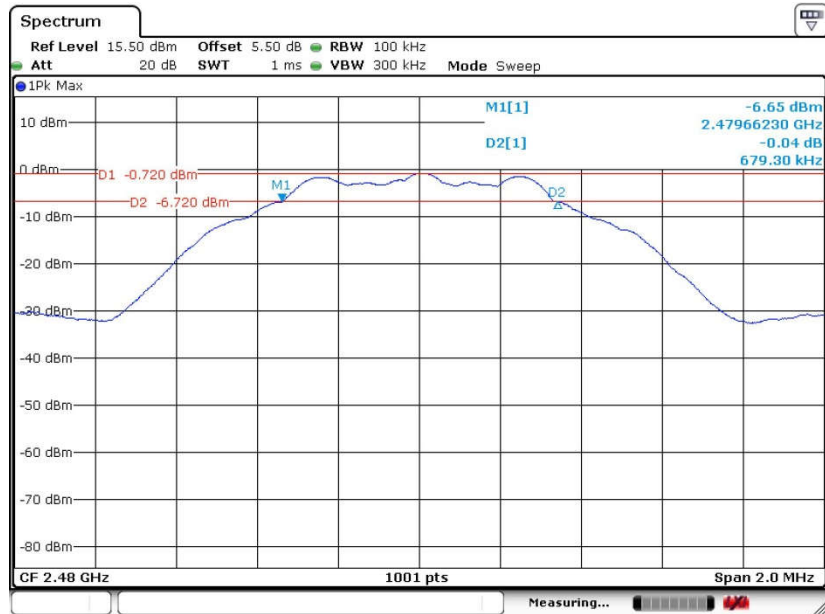

Date: 3.SEP.2016 01:15:57

## 3.2 Peak Output Power Measurement

### 3.2.1 Limit of Peak Output Power

For systems using digital modulation in the 2400-2483.5MHz, the limit for peak output power is 30dBm. If transmitting antenna of directional gain greater than 6dBi is used, the peak output power from the intentional radiator shall be reduced below the above stated value by the amount in dB that the directional gain of the antenna exceeds 6 dBi. In case of point-to-point operation, the limit has to be reduced by 1dB for every 3dB that the directional gain of the antenna exceeds 6dBi.

### 3.2.2 Measuring Instruments

The section 4.0 of List of Measuring Equipment of this test report is used for test.

### 3.2.3 Test Procedures

1. The testing follows the Measurement Procedure of FCC KDB No. 558074 DTS D01 Meas. Guidance v03r05 section 9.1.2 PKPM1 Peak power meter method.
2. The RF output of EUT was connected to the power meter by RF cable and attenuator. The path loss was compensated to the results for each measurement.
3. Set to the maximum power setting and enable the EUT transmit continuously.
4. Measure the conducted output power and record the results in the test report.

### 3.2.4 Test Setup

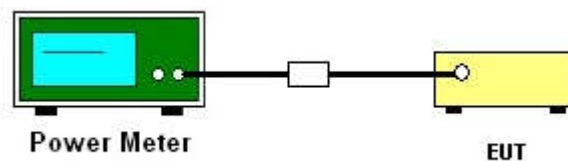

### 3.2.5 Test Result of Peak Output Power

Test data refers to Appendix A.

### 3.3 Power Spectral Density Measurement

#### 3.3.1 Limit of Power Spectral Density

The peak power spectral density shall not be greater than 8dBm in any 3kHz band at any time interval of continuous transmission.

#### 3.3.2 Measuring Instruments

The section 4.0 of List of Measuring Equipment of this test report is used for test.

#### 3.3.3 Test Procedures

1. The testing follows Measurement Procedure 10.2 Method PKPSD of FCC KDB Publication No. 558074 D01 DTS Meas. Guidance v03r05
2. The RF output of EUT was connected to the spectrum analyzer by RF cable and attenuator. The path loss was compensated to the results for each measurement.
3. Set to the maximum power setting and enable the EUT transmit continuously.
4. Make the measurement with the spectrum analyzer's resolution bandwidth (RBW) = 3 kHz. Video bandwidth VBW = 10 kHz In order to make an accurate measurement, set the span to 1.5 times DTS Channel Bandwidth. (6dB BW)
5. Detector = peak, Sweep time = auto couple, Trace mode = max hold, Allow trace to fully stabilize. Use the peak marker function to determine the maximum power level.
6. Measure and record the results in the test report.
7. The Measured power density (dBm)/ 100kHz is a reference level and used as 20dBc down limit line for Conducted Band Edges and Conducted Spurious Emission.

#### 3.3.4 Test Setup

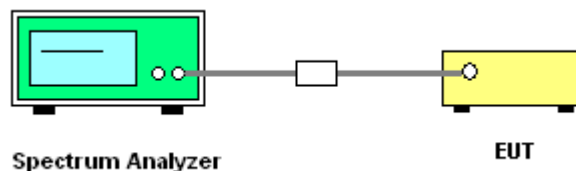



### 3.3.5 Test Result of Power Spectral Density

Test data refers to Appendix A.

### 3.3.6 Test Result of Power Spectral Density Plots (100kHz)

Bluetooth v4.0 LE

PSD 100kHz Plot on Channel 00

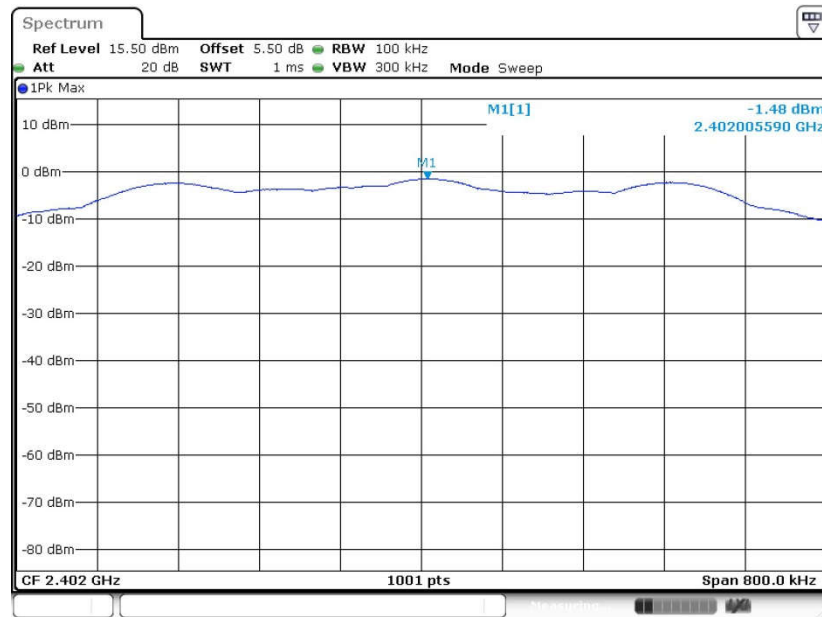

Date: 17.AUG.2016 00:09:31



PSD 100kHz Plot on Channel 19

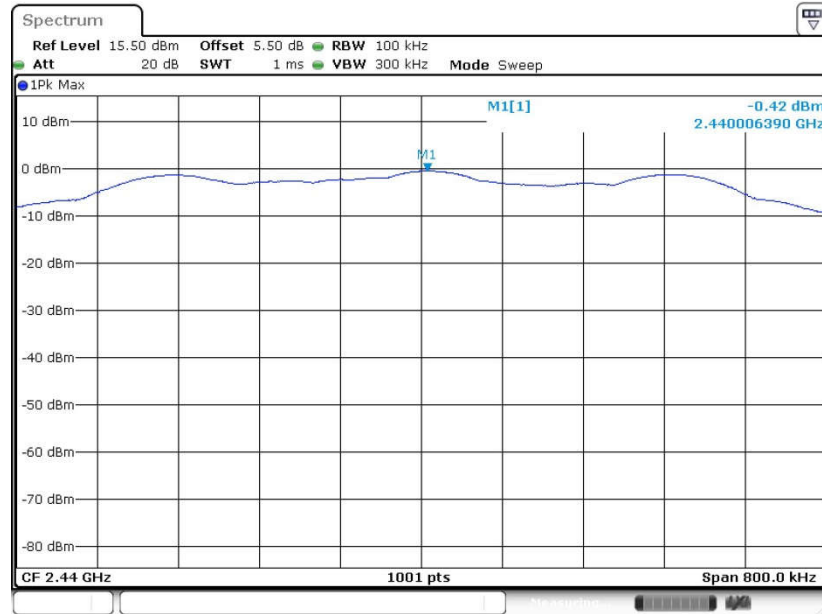

Date: 17.AUG.2016 00:13:00

PSD 100kHz Plot on Channel 39

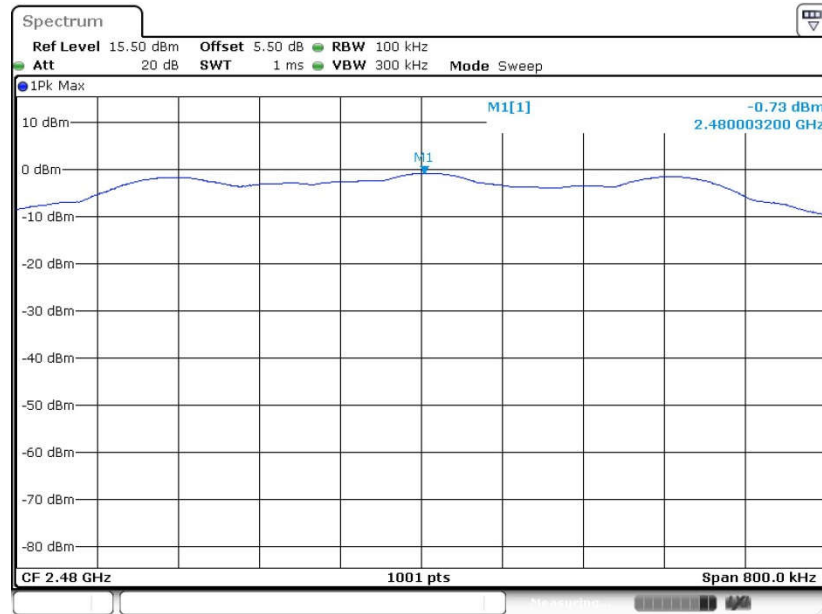

Date: 17.AUG.2016 00:15:19



Bluetooth v4.2 LE

PSD 100kHz Plot on Channel 00

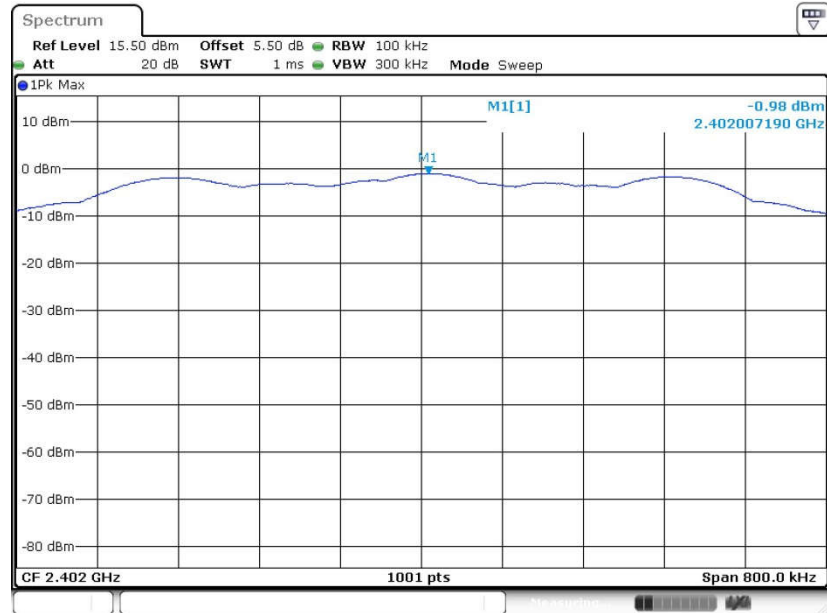

Date: 3.SEP.2016 01:07:44



PSD 100kHz Plot on Channel 19

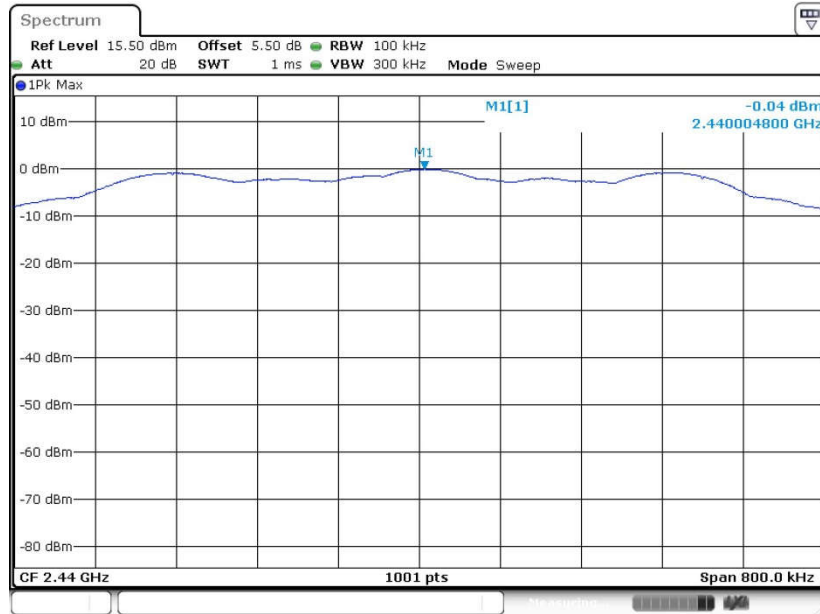

Date: 3.SEP.2016 01:12:43

PSD 100kHz Plot on Channel 39

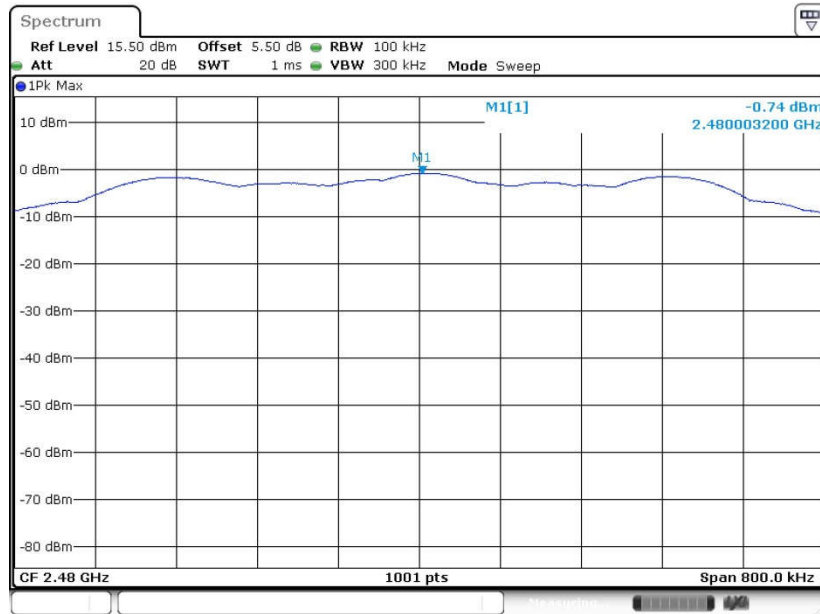

Date: 3.SEP.2016 01:16:38



### 3.3.7 Test Result of Power Spectral Density Plots (3kHz)

Bluetooth v4.0 LE

PSD 3kHz Plot on Channel 00

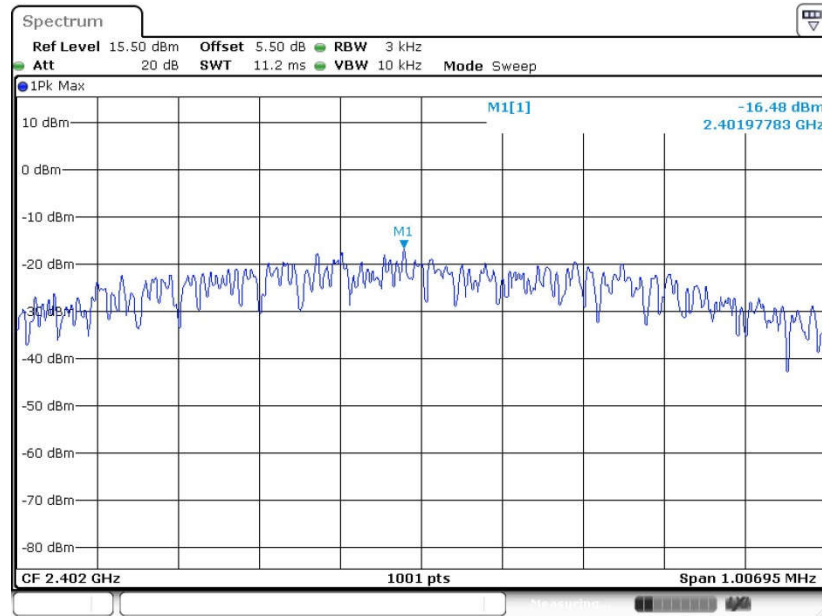

Date: 17.AUG.2016 00:09:17





PSD 3kHz Plot on Channel 19

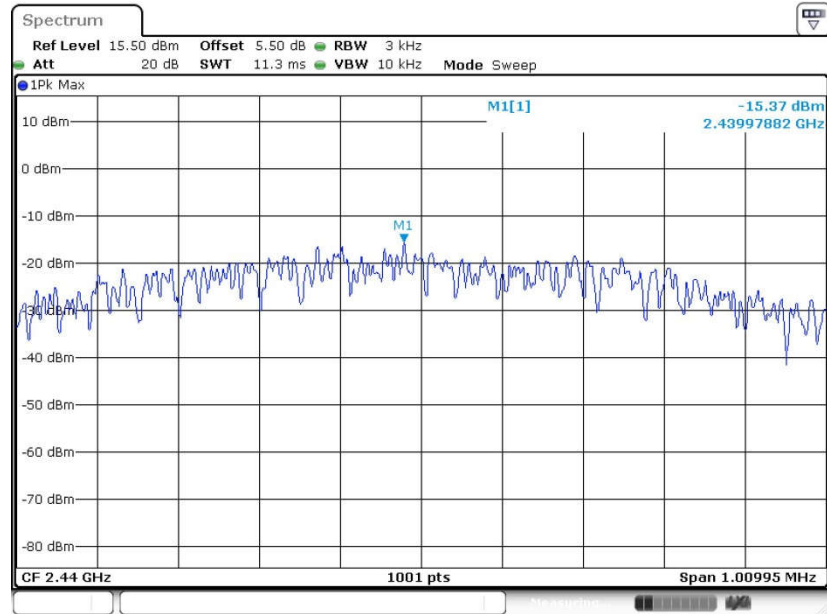

Date: 17.AUG.2016 00:12:43

PSD 3kHz Plot on Channel 39

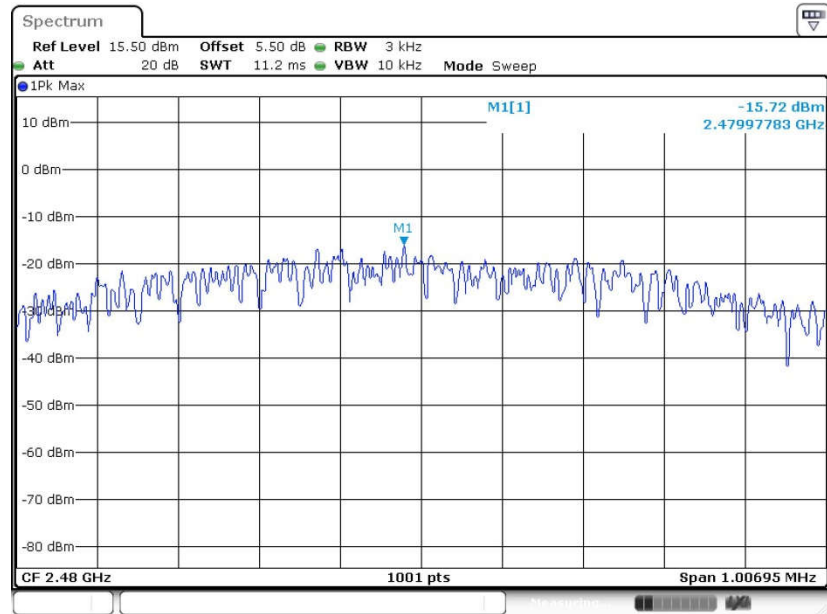

Date: 17.AUG.2016 00:14:57



Bluetooth v4.2 LE

PSD 3kHz Plot on Channel 00

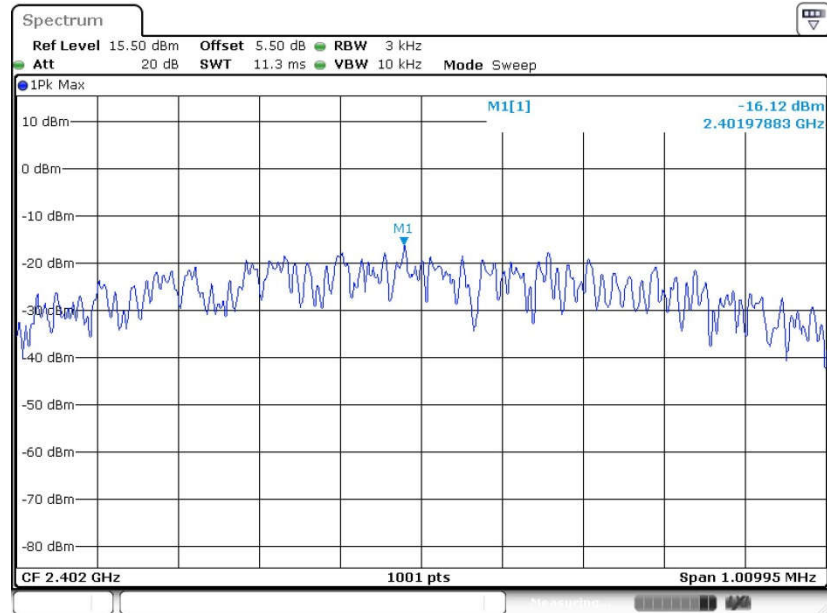

Date: 3.SEP.2016 01:07:23



PSD 3kHz Plot on Channel 19

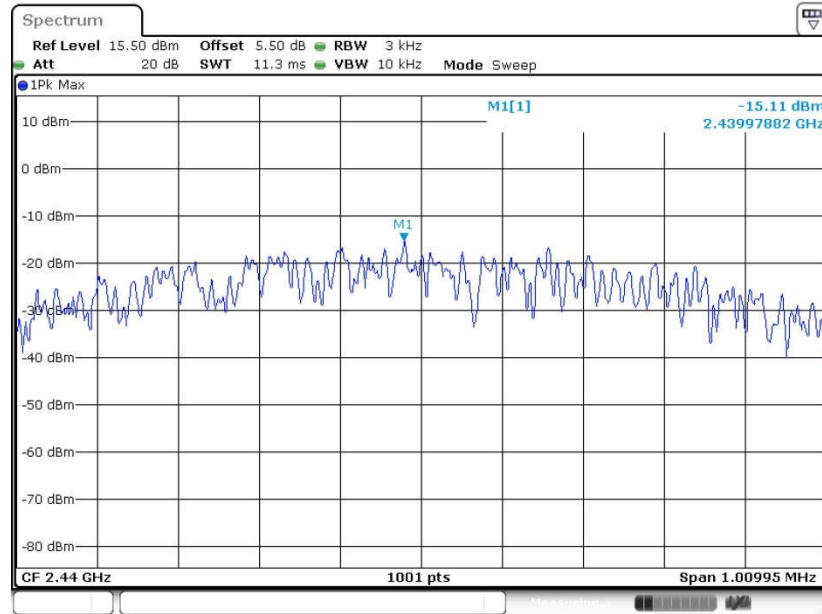

Date: 3.SEP.2016 01:12:28

PSD 3kHz Plot on Channel 39

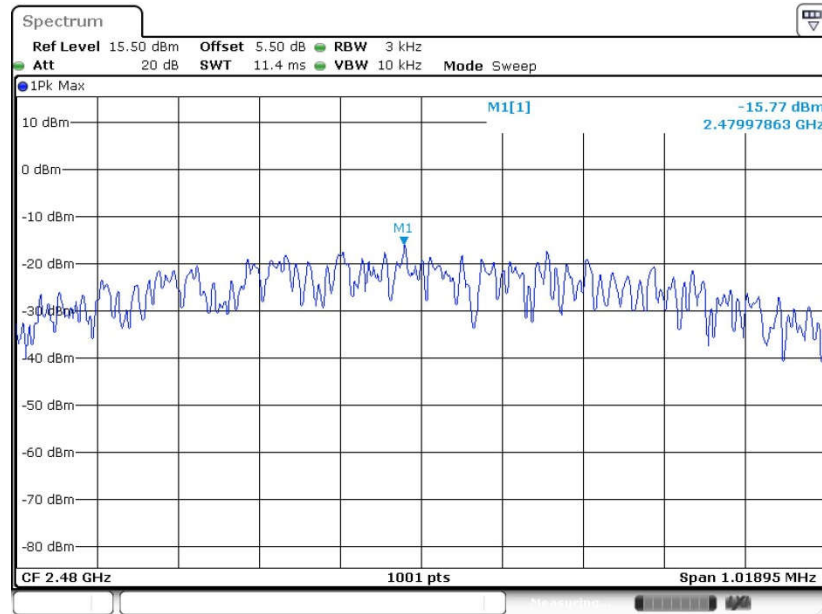

Date: 3.SEP.2016 01:16:24

## 3.4 Conducted Band Edges and Spurious Emission Measurement

### 3.4.1 Limit of Conducted Band Edges and Spurious Emission

All harmonics/spurious must be at least 20 dB down from the highest emission level within the authorized band.

### 3.4.2 Measuring Instruments

The section 4.0 of List of Measuring Equipment of this test report is used for test.

### 3.4.3 Test Procedure

1. The testing follows FCC KDB Publication No. 558074 D01 DTS Meas. Guidance v03r05.
2. The RF output of EUT was connected to the spectrum analyzer by RF cable and attenuator. The path loss was compensated to the results for each measurement.
3. Set to the maximum power setting and enable the EUT transmit continuously.
4. Set RBW = 100 kHz, VBW=300 kHz, Peak Detector. Unwanted Emissions measured in any 100 kHz bandwidth outside of the authorized frequency band shall be attenuated by at least 20 dB relative to the maximum in-band peak PSD level in 100 kHz when maximum peak conducted output power procedure is used. If the transmitter complies with the conducted power limits based on the use of RMS averaging over a time interval, the attenuation required under this paragraph shall be 30 dB instead of 20 dB per 15.247(d).
5. Measure and record the results in the test report.
6. The RF fundamental frequency should be excluded against the limit line in the operating frequency band.

### 3.4.4 Test Setup

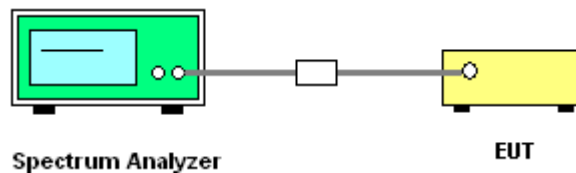



### 3.4.5 Test Result of Conducted Band Edges Plots

Bluetooth v4.0 LE

Low Band Edge Plot on Channel 00

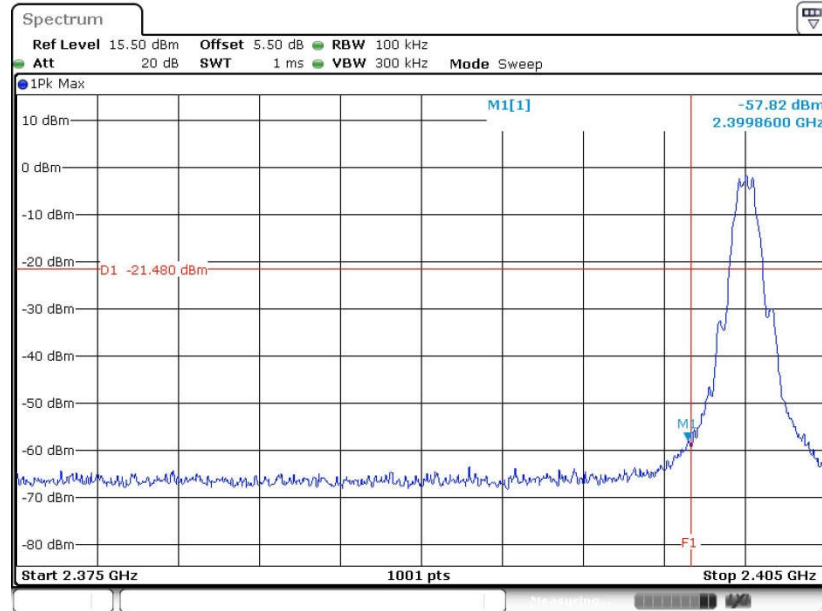

Date: 17.AUG.2016 00:09:56



High Band Edge Plot on Channel 39

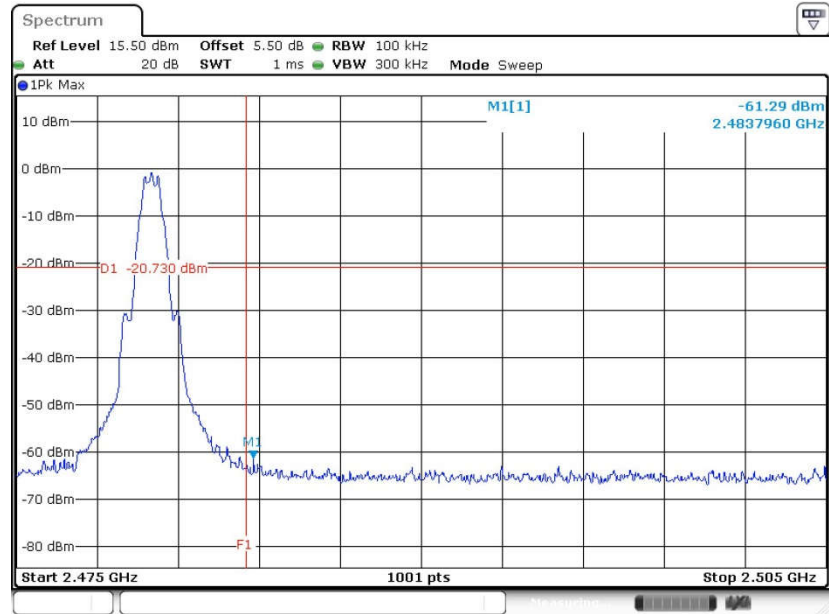

Date: 17.AUG.2016 00:15:53





High Band Edge Plot on Channel 39

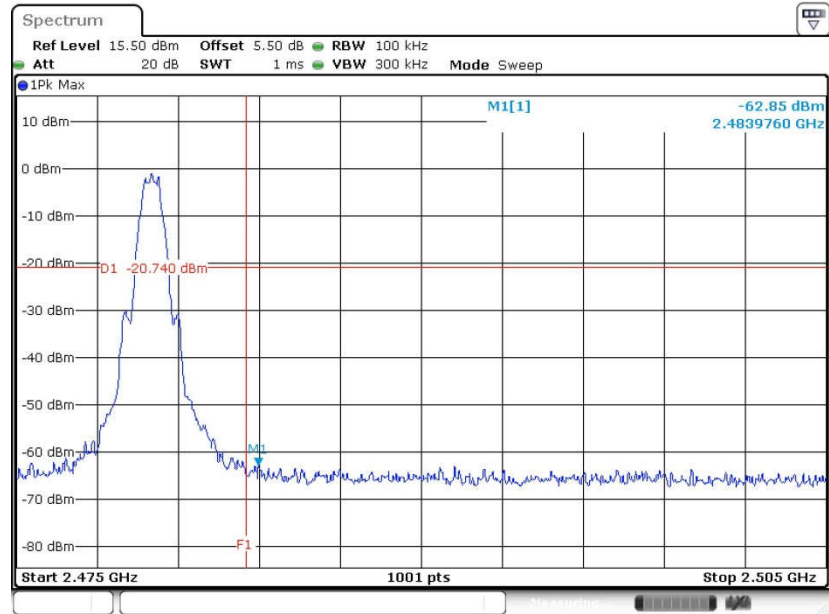

Date: 3.SEP.2016 01:16:48





### 3.4.6 Test Result of Conducted Spurious Emission Plots

Bluetooth v4.0 LE

#### Conducted Spurious Emission Plot on Bluetooth LE 1Mbps GFSK Channel 00

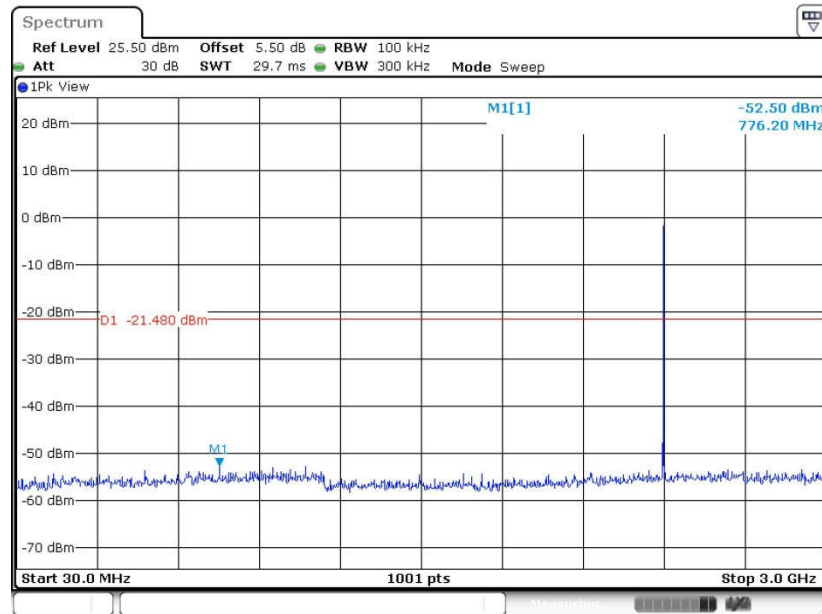

Date: 17.AUG.2016 00:10:07



Conducted Spurious Emission Plot on Bluetooth LE 1Mbps  
GFSK Channel 00

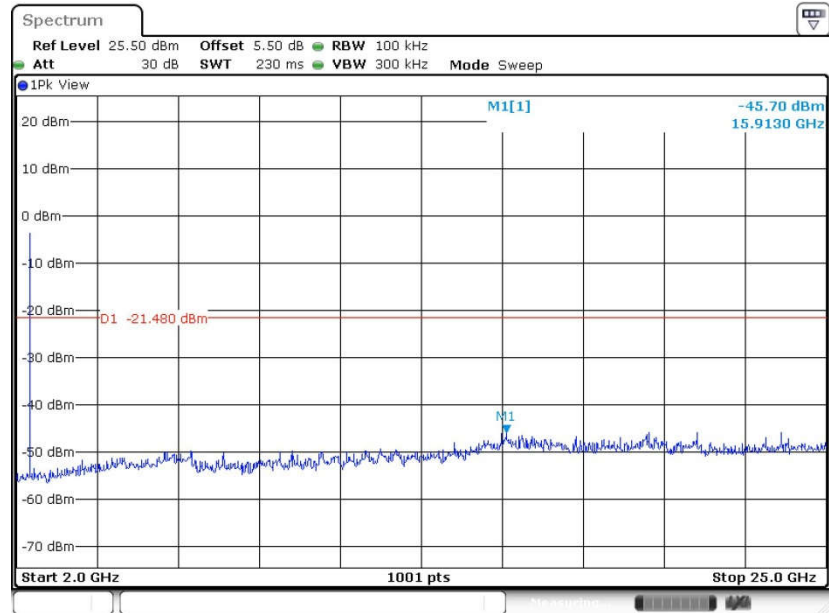

Date: 17.AUG.2016 00:10:15



Conducted Spurious Emission Plot on Bluetooth LE 1Mbps  
GFSK Channel 19

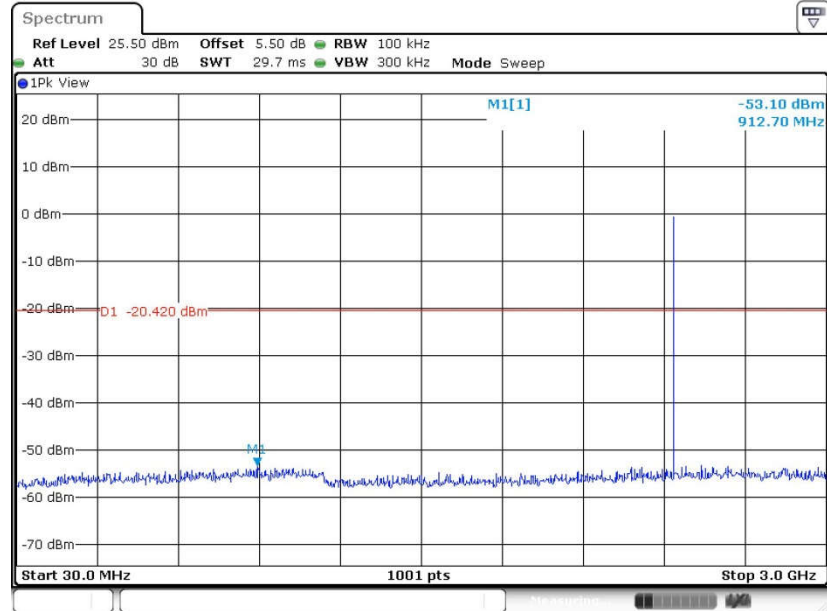

Date: 17.AUG.2016 00:13:11



Conducted Spurious Emission Plot on Bluetooth LE 1Mbps  
GFSK Channel 19

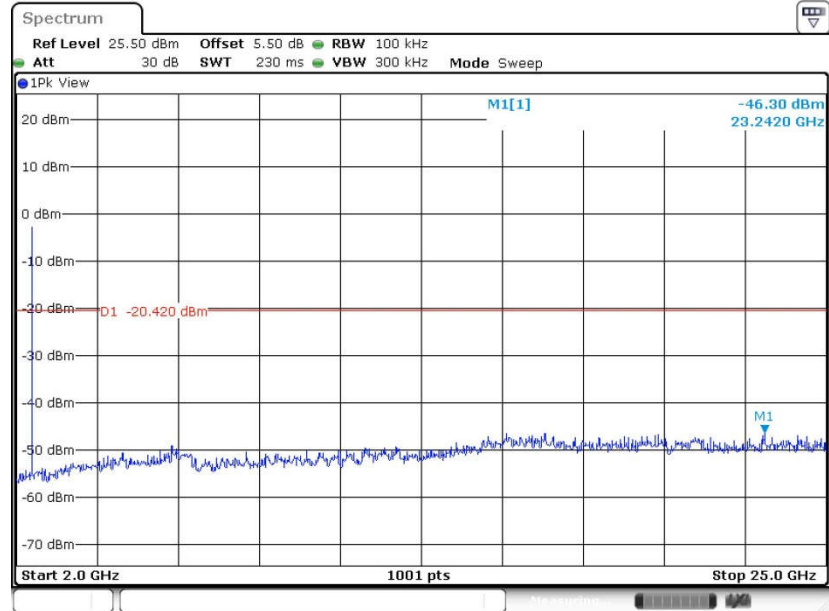

Date: 17.AUG.2016 00:13:20



Conducted Spurious Emission Plot on Bluetooth LE 1Mbps  
GFSK Channel 39

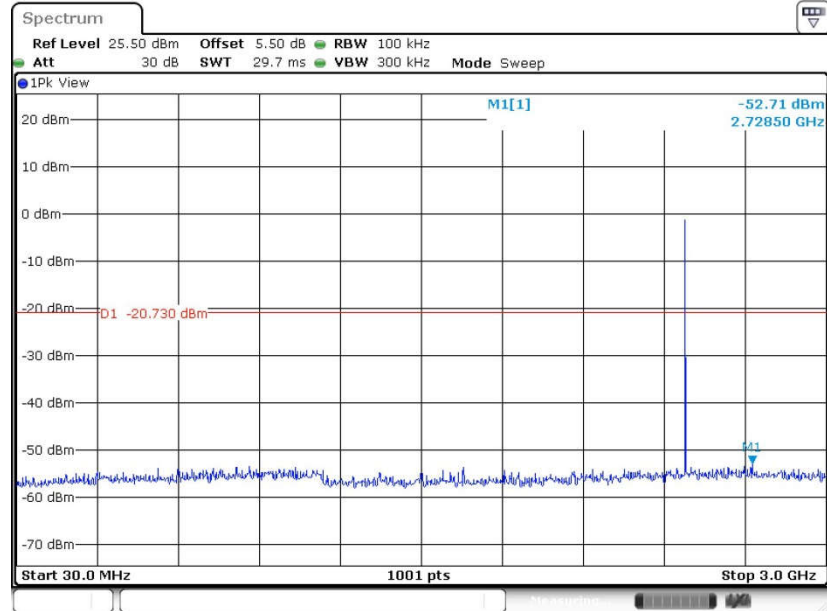

Date: 17.AUG.2016 00:16:05



Conducted Spurious Emission Plot on Bluetooth LE 1Mbps  
GFSK Channel 39

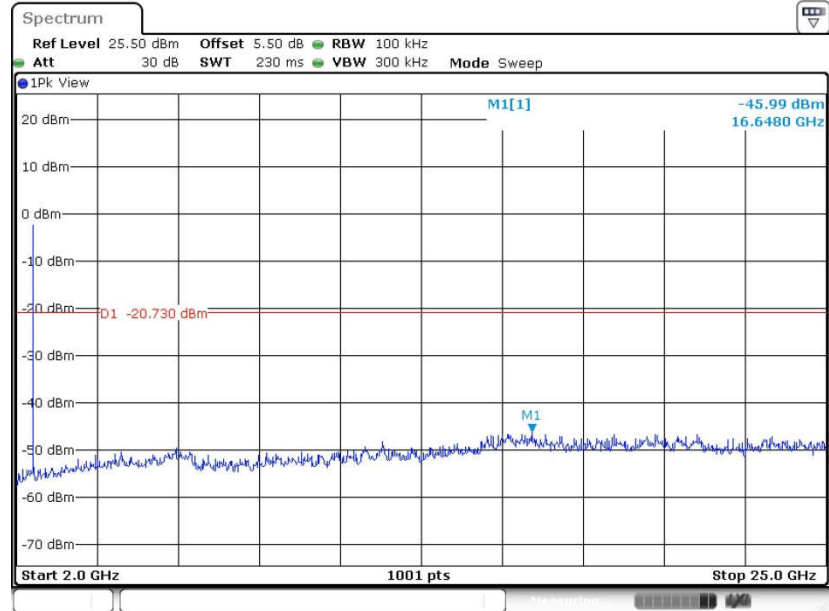

Date: 17.AUG.2016 00:16:14



Bluetooth v4.2 LE

Conducted Spurious Emission Plot on Bluetooth LE 1Mbps  
GFSK Channel 00

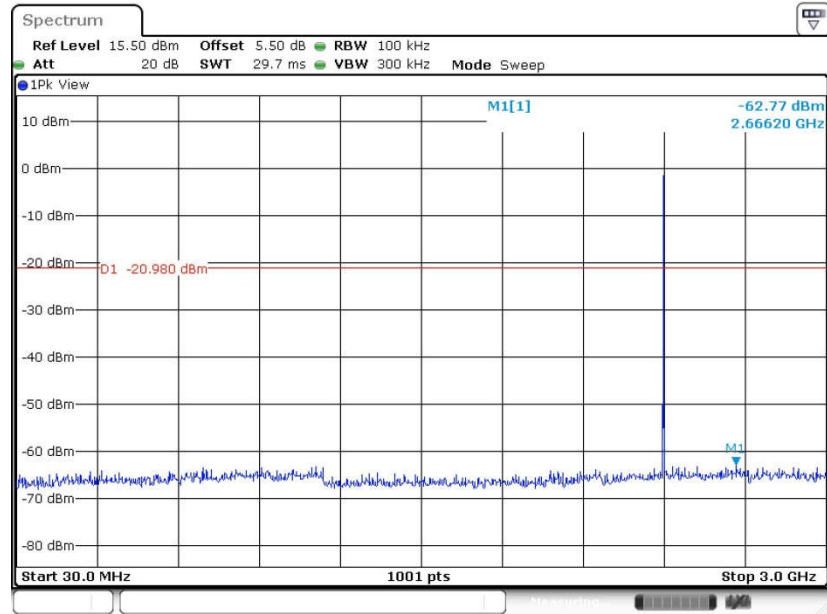

Date: 3.SEP.2016 01:09:04



Conducted Spurious Emission Plot on Bluetooth LE 1Mbps  
GFSK Channel 00

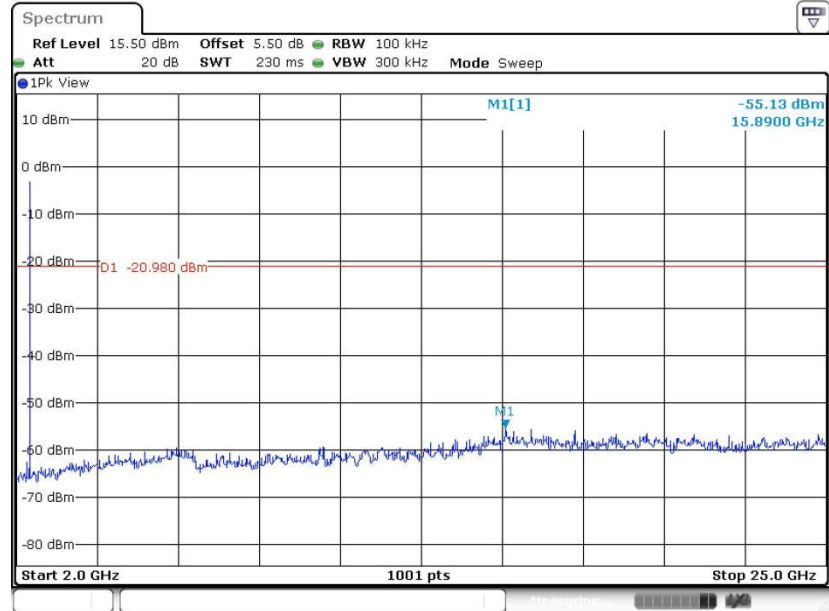

Date: 3.SEP.2016 01:09:12





Conducted Spurious Emission Plot on Bluetooth LE 1Mbps  
GFSK Channel 19

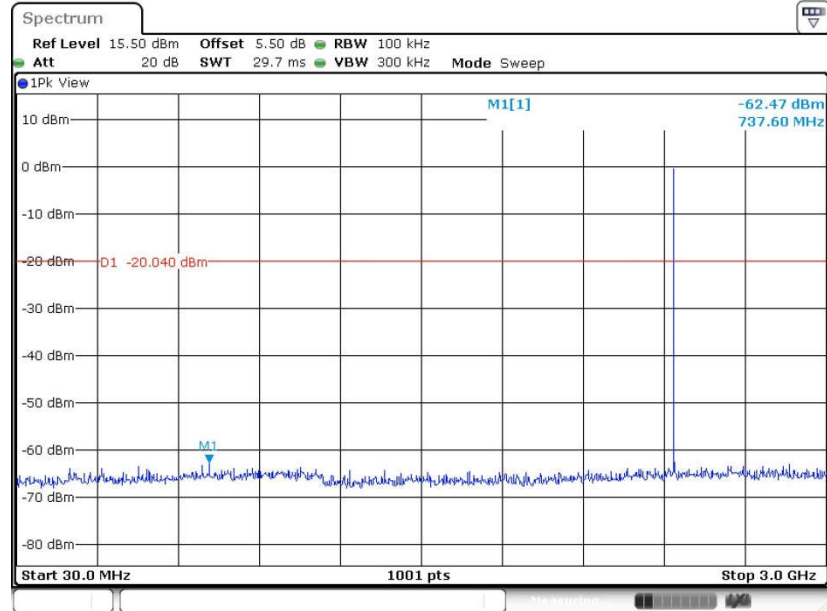

Date: 3.SEP.2016 01:12:55



Conducted Spurious Emission Plot on Bluetooth LE 1Mbps  
GFSK Channel 19

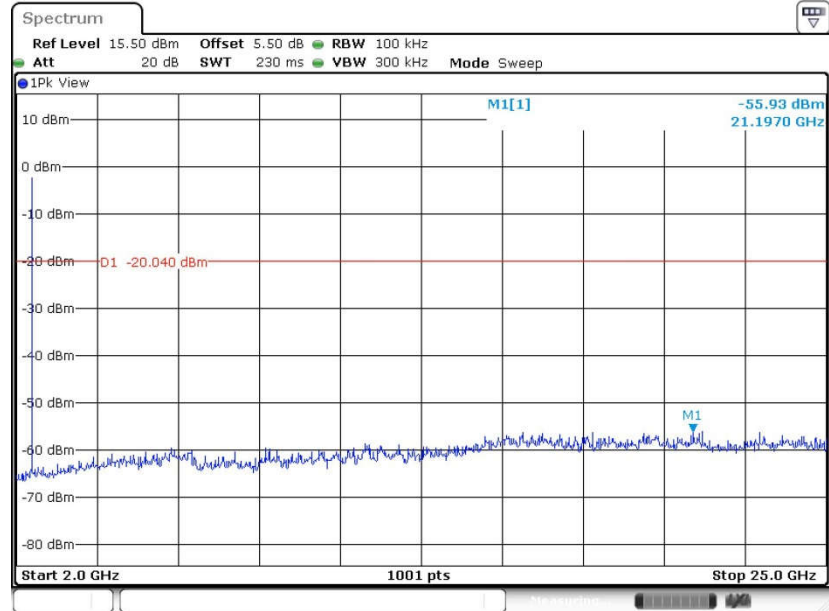

Date: 3.SEP.2016 01:13:03



Conducted Spurious Emission Plot on Bluetooth LE 1Mbps  
GFSK Channel 39

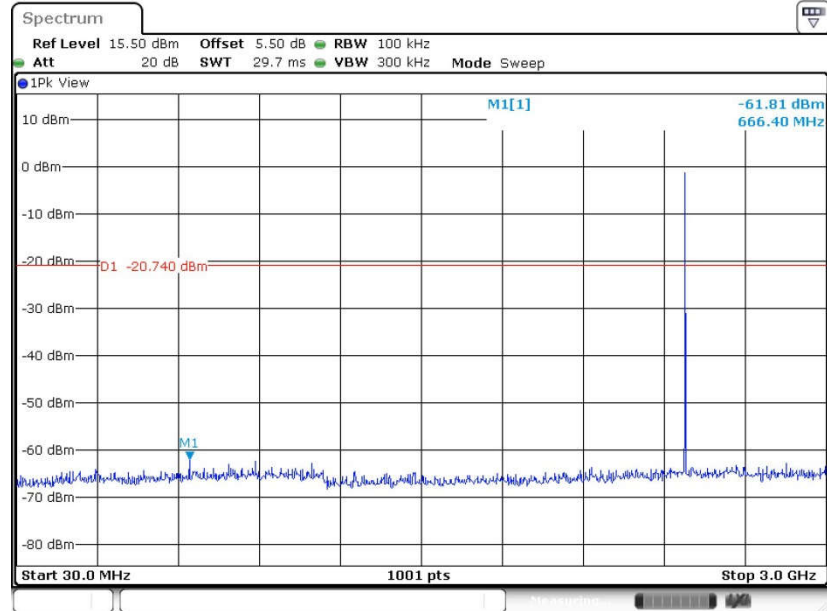

Date: 3.SEP.2016 01:17:02



Conducted Spurious Emission Plot on Bluetooth LE 1Mbps  
GFSK Channel 39

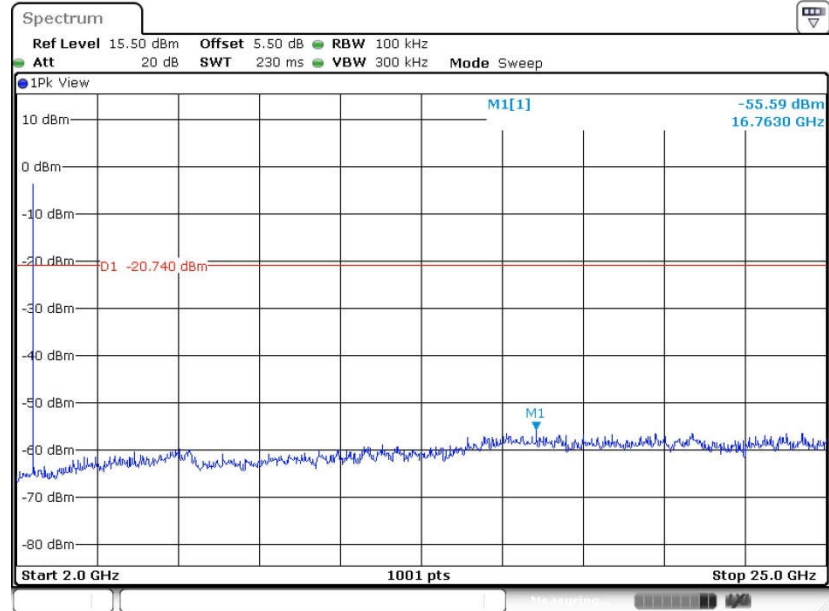

Date: 3.SEP.2016 01:17:10



### 3.5 Radiated Band Edges and Spurious Emission Measurement

#### 3.5.1 Limit of Radiated Band Edges and Spurious Emission

In any 100 kHz bandwidth outside the intentional radiator frequency band, all harmonics/spurious must be at least 20 dB below the highest emission level within the authorized band. If the output power of this device was measured by spectrum analyzer, the attenuation under this paragraph shall be 30 dB instead of 20 dB. In addition, radiated emissions which fall in the restricted bands must also comply with the FCC section 15.209 limits as below.

Frequency (MHz)	Field Strength (microvolts/meter)	Measurement Distance (meters)
0.009 – 0.490	2400/F(kHz)	300
0.490 – 1.705	24000/F(kHz)	30
1.705 – 30.0	30	30
30 – 88	100	3
88 – 216	150	3
216 - 960	200	3
Above 960	500	3

#### 3.5.2 Measuring Instruments

The section 4.0 of List of Measuring Equipment of this test report is used for test.



### 3.5.3 Test Procedures

1. The testing follows FCC KDB Publication No. 558074 D01 DTS Meas. Guidance v03r05.
2. The EUT was arranged to its worst case and then tune the antenna tower (from 1 m to 4 m) and turntable (from 0 degree to 360 degrees) to find the maximum reading. A pre-amp and a high pass filter are used for the test in order to get better signal level.
3. The EUT was placed on a turntable with 0.8 meter for frequency below 1GHz and 1.5 meter for frequency above 1GHz respectively above ground.
4. The EUT was set 3 meters from the interference receiving antenna, which was mounted on the top of a variable height antenna tower.
5. Corrected Reading: Antenna Factor + Cable Loss + Read Level - Preamp Factor = Level
6. For measurement below 1GHz, If the emission level of the EUT measured by the peak detector is 3 dB lower than the applicable limit, the peak emission level will be reported. Otherwise, the emission measurement will be repeated using the quasi-peak detector and reported.
7. Use the following spectrum analyzer settings:
  - (1) Span shall wide enough to fully capture the emission being measured;
  - (2) Set RBW=100 kHz for  $f < 1$  GHz; VBW  $\geq$  RBW; Sweep = auto; Detector function = peak; Trace = max hold;
  - (3) Set RBW = 1 MHz, VBW= 3MHz for  $f \geq 1$  GHz for peak measurement.  
For average measurement:
    - VBW = 10 Hz, when duty cycle is no less than 98 percent.
    - VBW  $\geq 1/T$ , when duty cycle is less than 98 percent where T is the minimum transmission duration over which the transmitter is on and is transmitting at its maximum power control level for the tested mode of operation.

### 3.5.4 Test Setup

For radiated emissions below 30MHz

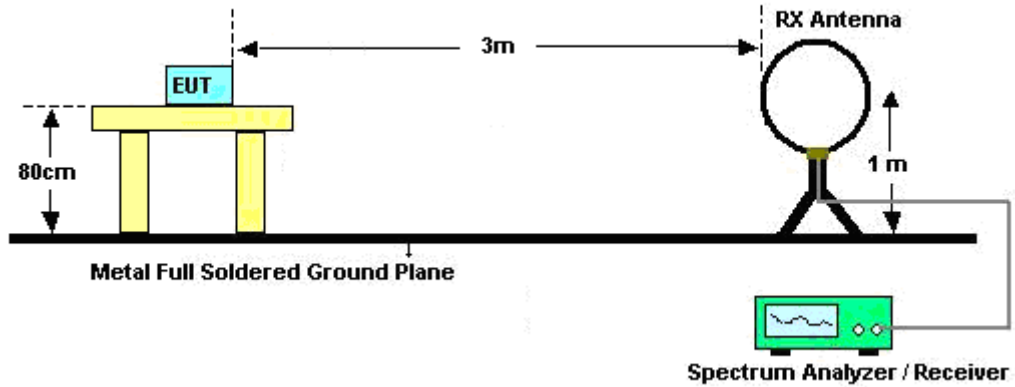

For radiated emissions from 30MHz to 1GHz

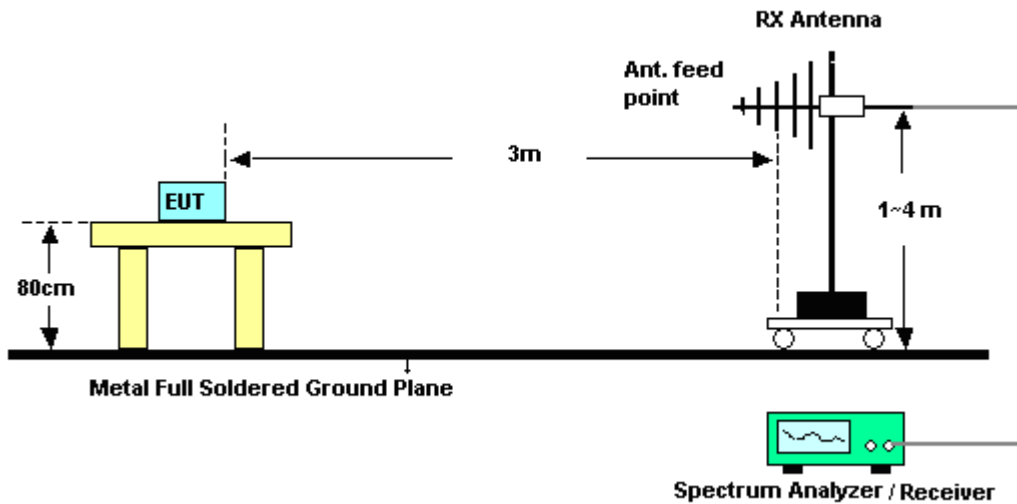

For radiated emissions above 1GHz

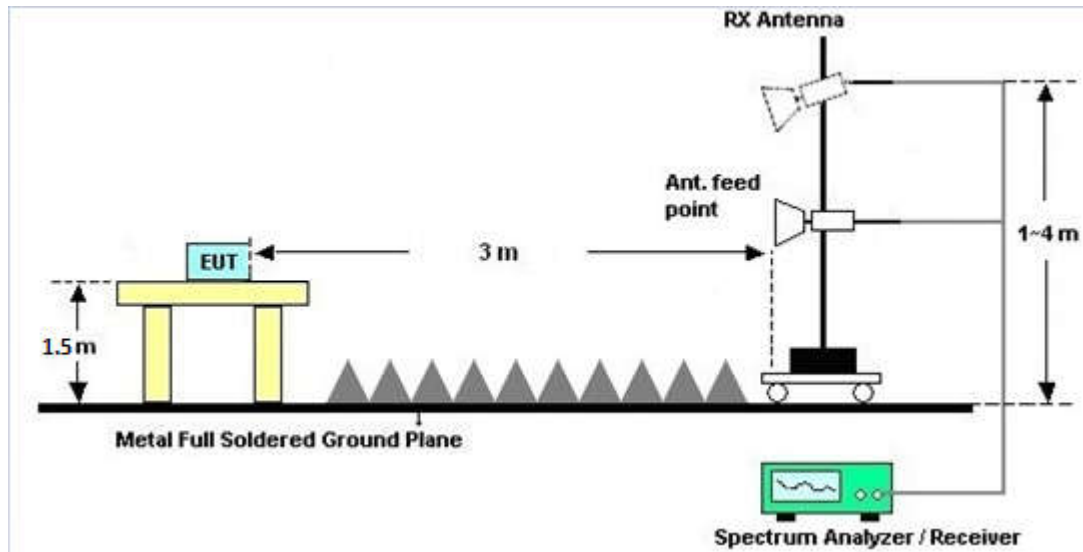

### 3.5.5 Test Results of Radiated Spurious Emissions (9 kHz ~ 30 MHz)

The low frequency, which started from 9 kHz to 30MHz, was pre-scanned and the result which was 20dB lower than the limit line per 15.31(o) was not reported.

### 3.5.6 Test Result of Radiated Spurious at Band Edges

Please refer to Appendix B.

### 3.5.7 Duty Cycle

Please refer to Appendix C.

### 3.5.8 Test Result of Radiated Spurious Emission (30MHz ~ 10th Harmonic)

Please refer to Appendix B.





### 3.6 AC Conducted Emission Measurement

#### 3.6.1 Limit of AC Conducted Emission

For equipment that is designed to be connected to the public utility (AC) power line, the radio frequency voltage that is conducted back onto the AC power line on any frequency or frequencies within the band 150 kHz to 30 MHz shall not exceed the limits in the following table.

Frequency of emission (MHz)	Conducted limit (dB $\mu$ V)	
	Quasi-peak	Average
0.15-0.5	66 to 56*	56 to 46*
0.5-5	56	46
5-30	60	50

\*Decreases with the logarithm of the frequency.

#### 3.6.2 Measuring Instruments

The section 4.0 of List of Measuring Equipment of this test report is used for test.

#### 3.6.3 Test Procedures

1. The EUT was placed 0.4 meter from the conducting wall of the shielding room was kept at least 80 centimeters from any other grounded conducting surface.
2. Connect EUT to the power mains through a line impedance stabilization network (LISN).
3. All the support units are connecting to the other LISN.
4. The LISN provides 50 ohm coupling impedance for the measuring instrument.
5. The FCC states that a 50 ohm, 50 microhenry LISN should be used.
6. Both sides of AC line were checked for maximum conducted interference.
7. The frequency range from 150 kHz to 30 MHz was searched.
8. Set the test-receiver system to Peak Detect Function and specified bandwidth (IF Bandwidth = 9kHz) with Maximum Hold Mode. Then measurement is also conducted by Average Detector and Quasi-Peak Detector Function respectively.

### 3.6.4 Test Setup

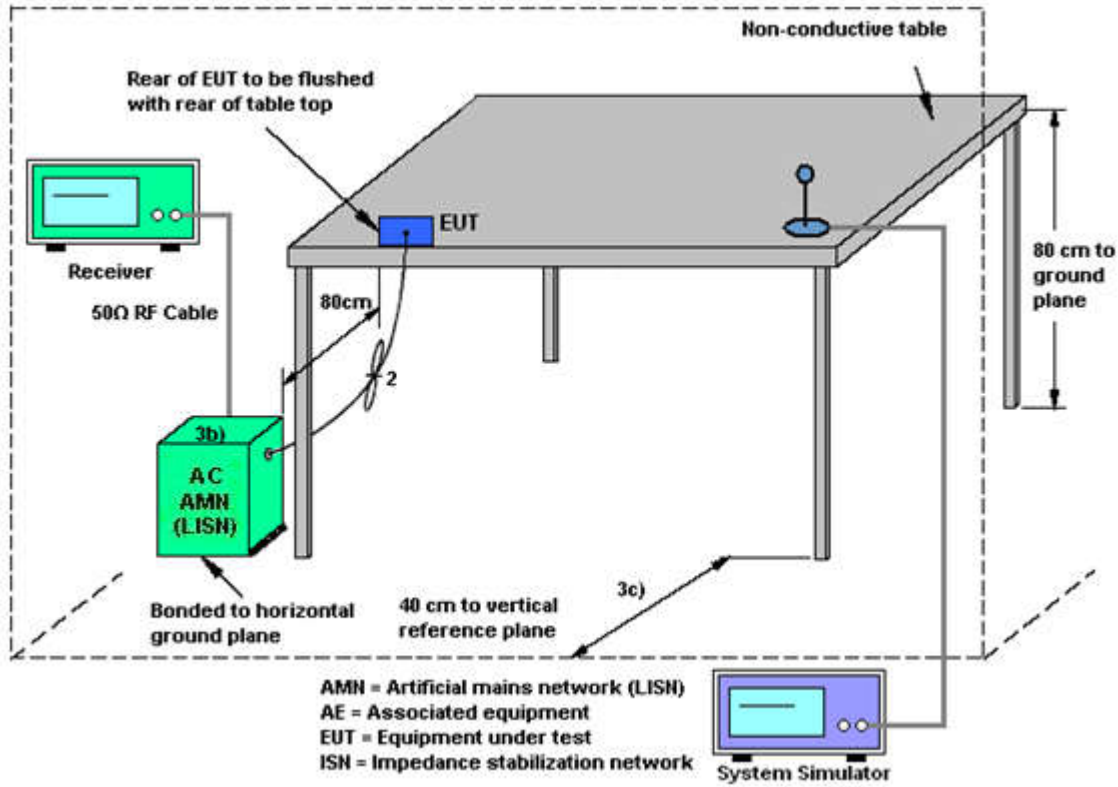



3.6.5 Test Result of AC Conducted Emission

Test Mode :	Mode 2	Temperature :	22~24°C
Test Engineer :	Morris Li	Relative Humidity :	42~44%
Test Voltage :	120Vac / 60Hz	Phase :	Line
Function Type :	GSM850 Idle + Bluetooth Link + WLAN Link + Earphone + USB Cable 2(Charging from Adapter 2) for Sample 2		

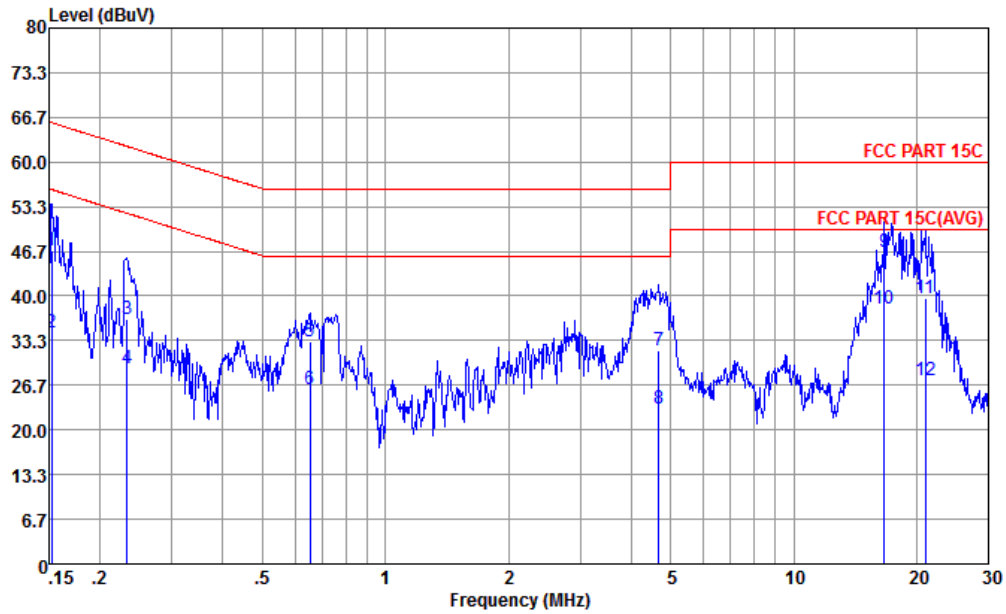

Site : CO01-KS  
 Condition : FCC PART 15C LISN-L-20151024 LINE

mode : Mode 2  
 IMEI : 861902030000132

	Freq	Level	Over Limit	Limit Line	Read Level	LISN Factor	Cable Loss	Remark
	MHz	dBuV	dB	dBuV	dBuV	dB	dB	
1	0.152	46.82	-19.05	65.87	36.20	0.51	10.11	QP
2	0.152	34.52	-21.35	55.87	23.90	0.51	10.11	Average
3	0.233	36.46	-25.89	62.35	26.10	0.22	10.14	QP
4	0.233	29.26	-23.09	52.35	18.90	0.22	10.14	Average
5	0.654	33.29	-22.71	56.00	22.90	0.24	10.15	QP
6	0.654	26.09	-19.91	46.00	15.70	0.24	10.15	Average
7	4.672	31.77	-24.23	56.00	21.40	0.19	10.18	QP
8	4.672	23.27	-22.73	46.00	12.90	0.19	10.18	Average
9	16.661	46.50	-13.50	60.00	35.80	0.26	10.44	QP
10 *	16.661	38.20	-11.80	50.00	27.50	0.26	10.44	Average
11	21.035	39.73	-20.27	60.00	28.90	0.26	10.57	QP
12	21.035	27.33	-22.67	50.00	16.50	0.26	10.57	Average



Test Mode :	Mode 2	Temperature :	22~24°C
Test Engineer :	Morris Li	Relative Humidity :	42~44%
Test Voltage :	120Vac / 60Hz	Phase :	Neutral
Function Type :	GSM850 Idle + Bluetooth Link + WLAN Link + Earphone + USB Cable 2(Charging from Adapter 2) for Sample 2		

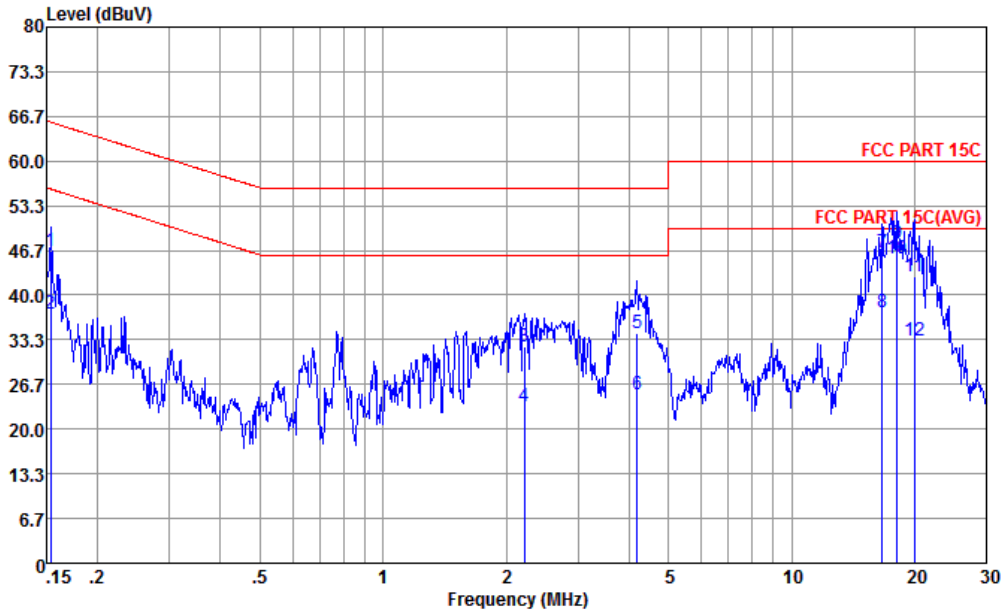

Site : CO01-KS  
 Condition : FCC PART 15C LISN-N-20151024 NEUTRAL

mode : Mode 2  
 IMEI : 861902030000132

	Freq	Level	over Limit	Limit Line	Read Level	LISN Factor	Cable Loss	Remark
	MHz	dBuV	dB	dBuV	dBuV	dB	dB	
1	0.153	46.61	-19.21	65.82	36.20	0.30	10.11	QP
2	0.153	37.11	-18.71	55.82	26.70	0.30	10.11	Average
3	2.213	32.42	-23.58	56.00	21.90	0.38	10.14	QP
4	2.213	23.42	-22.58	46.00	12.90	0.38	10.14	Average
5	4.180	34.23	-21.77	56.00	23.70	0.36	10.17	QP
6	4.180	25.13	-20.87	46.00	14.60	0.36	10.17	Average
7	16.661	46.40	-13.60	60.00	35.70	0.26	10.44	QP
8	16.661	37.50	-12.50	50.00	26.80	0.26	10.44	Average
9	18.135	47.64	-12.36	60.00	36.90	0.26	10.48	QP
10 *	18.135	45.44	-4.56	50.00	34.70	0.26	10.48	Average
11	19.950	42.68	-17.32	60.00	31.90	0.25	10.53	QP
12	19.950	33.18	-16.82	50.00	22.40	0.25	10.53	Average



## **3.7 Antenna Requirements**

### **3.7.1 Standard Applicable**

If directional gain of transmitting antennas is greater than 6dBi, the power shall be reduced by the same level in dB comparing to gain minus 6dBi. The use of a permanently attached antenna or of an antenna that uses a unique coupling to the intentional radiator shall be considered sufficient to comply with the FCC rule.

### **3.7.2 Antenna Anti-Replacement Construction**

An embedded-in antenna design is used.

### **3.7.3 Antenna Gain**

The antenna peak gain of EUT is less than 6 dBi. Therefore, it is not necessary to reduce maximum peak output power limit.



## 4 List of Measuring Equipment

Instrument	Manufacturer	Model No.	Serial No.	Characteristics	Calibration Date	Test Date	Due Date	Remark
Spectrum Analyzer	R&S	FSV40	101040	10Hz~40GHz	Sep. 10, 2015	Aug. 14, 2016~ Sep. 03, 2016	Sep. 09, 2016	Conducted (TH01-KS)
Pulse Power Sensor	Anritsu	MA2411B	0917070	300MHz~40GHz	Jan. 20, 2016	Aug. 14, 2016~ Sep. 03, 2016	Jan. 19, 2017	Conducted (TH01-KS)
Power Meter	Anritsu	ML2495A	1005002	50MHz Bandwidth	Jan. 20, 2016	Aug. 14, 2016~ Sep. 03, 2016	Jan. 19, 2017	Conducted (TH01-KS)
EMI Test Receiver	R&S	ESR7	101403	9kHz~7GHz; Max 30dBm	Aug. 09, 2016	Aug. 14, 2016~ Aug. 30, 2016	Aug. 08, 2017	Radiation (03CH03-KS)
EXA Spectrum Analyzer	Keysight	N9010A	MY5515024 4	10Hz~44GHz	Apr. 22, 2016	Aug. 14, 2016~ Aug. 30, 2016	Apr. 21, 2017	Radiation (03CH03-KS)
Loop Antenna	R&S	HFH2-Z2	100321	9kHz~30MHz	Nov. 07, 2015	Aug. 14, 2016~ Aug. 30, 2016	Nov. 06, 2016	Radiation (03CH03-KS)
Bilog Antenna	TeseQ	CBL6112D	35406	25MHz~2GHz	Apr. 16, 2016	Aug. 14, 2016~ Aug. 30, 2016	Apr. 15, 2017	Radiation (03CH03-KS)
Horn Antenna	Schwarzbeck	BBHA9120D	9120D-1356	1GHz~18GHz	Apr. 16, 2016	Aug. 14, 2016~ Aug. 30, 2016	Apr. 15, 2017	Radiation (03CH03-KS)
SHF-EHF Horn	Schwarzbeck	BBHA 9170	BBHA17024 9	15GHz ~40GHz	Mar. 03, 2016	Aug. 14, 2016~ Aug. 30, 2016	Mar. 02, 2017	Radiation (03CH03-KS)
Amplifier	SONOMA	310N	187289	9kHz~1GHz	Aug. 09, 2016	Aug. 14, 2016~ Aug. 30, 2016	Aug. 08, 2017	Radiation (03CH03-KS)
Amplifier	MITEQ	TTA1840-35- HG	1887435	18~40GHz	Aug. 27, 2015	Aug. 14, 2016~ Aug. 30, 2016	Aug. 26, 2016	Radiation (03CH03-KS)
Amplifier	Agilent	8449B	3008A02370	1GHz~26.5GHz	Oct. 24, 2015	Aug. 14, 2016~ Aug. 30, 2016	Oct. 23, 2016	Radiation (03CH03-KS)
AC Power Source	Chroma	61601	F104090004	N/A	NCR	Aug. 14, 2016~ Aug. 30, 2016	NCR	Radiation (03CH03-KS)
Turn Table	ChamPro	EM 1000-T	060762-T	0~360 degree	NCR	Aug. 14, 2016~ Aug. 30, 2016	NCR	Radiation (03CH03-KS)



Instrument	Manufacturer	Model No.	Serial No.	Characteristics	Calibration Date	Test Date	Due Date	Remark
Antenna Mast	ChamPro	EM 1000-A	060762-A	1 m~4 m	NCR	Aug. 14, 2016~ Aug. 30, 2016	NCR	Radiation (03CH03-KS)
EMI Test Receiver	R&S	ESR7	101403	9kHz~7GHz; Max 30dBm	Aug. 09, 2016	Aug. 14, 2016~ Aug. 30, 2016	Aug. 08, 2017	Radiation (03CH02-KS)
EXA Spectrum Analyzer	Keysight	N9010A	MY5515020 8	10Hz~44GHz; Max 30dB	Apr. 22, 2016	Aug. 14, 2016~ Aug. 30, 2016	Apr. 21, 2017	Radiation (03CH02-KS)
Loop Antenna	R&S	HFH2-Z2	100321	9kHz~30MHz	Nov. 07, 2015	Aug. 14, 2016~ Aug. 30, 2016	Nov. 06, 2016	Radiation (03CH02-KS)
Bilog Antenna	TeseQ	CBL6112D	37879	30MHz~2GHz	Sep. 12, 2015	Aug. 14, 2016~ Aug. 30, 2016	Sep. 11, 2016	Radiation (03CH02-KS)
Double Ridge Horn Antenna	ETS-Lindgren	3117	75957	1GHz~18GHz	Nov. 07, 2015	Aug. 14, 2016~ Aug. 30, 2016	Nov. 06, 2016	Radiation (03CH02-KS)
SHF-EHF Horn	com-power	AH-840	101070	18GHz~40GHz	Oct. 10, 2015	Aug. 14, 2016~ Aug. 30, 2016	Oct. 09, 2016	Radiation (03CH02-KS)
Amplifier	com-power	PA-103A	161069	1kHz~1000MHz / 32 dB	Apr. 22, 2016	Aug. 14, 2016~ Aug. 30, 2016	Apr. 21, 2017	Radiation (03CH02-KS)
High Gain Amplifier	MITEQ	AMF-7D-0010 1800-30-10P	1865802	1GHz~18GHz	Jan. 20, 2016	Aug. 14, 2016~ Aug. 30, 2016	Jan. 19, 2017	Radiation (03CH02-KS)
Amplifier	Agilent	8449B	3008A02384	1GHz~26.5GHz	Oct. 24, 2015	Aug. 14, 2016~ Aug. 30, 2016	Oct. 23, 2016	Radiation (03CH02-KS)
Amplifier	MITEQ	TTA1840-35- HG	1887435	18GHz~40GHz	Jan. 20, 2016	Aug. 14, 2016~ Aug. 30, 2016	Jan. 19, 2017	Radiation (03CH02-KS)
AC Power Source	Chroma	61601	6160100024 73	N/A	NCR	Aug. 14, 2016~ Aug. 30, 2016	NCR	Radiation (03CH02-KS)
Turn Table	MF	MF7802	N/A	0~360 degree	NCR	Aug. 14, 2016~ Aug. 30, 2016	NCR	Radiation (03CH02-KS)
Antenna Mast	MF	MF7802	N/A	1 m~4 m	NCR	Aug. 14, 2016~ Aug. 30, 2016	NCR	Radiation (03CH02-KS)
EMI Test Receiver	R&S	ESR7	101403	9kHz~7GHz; Max 30dBm	Aug. 09, 2016	Aug. 20, 2016	Aug. 08, 2017	Conduction (CO01-KS)
AC LISN	MessTec	AN3016	060103	9kHz~30MHz	Oct. 24, 2015	Aug. 20, 2016	Oct. 23, 2016	Conduction (CO01-KS)
AC LISN (for auxiliary equipment)	MessTec	AN3016	060105	9kHz~30MHz	Oct. 24, 2015	Aug. 20, 2016	Oct. 23, 2016	Conduction (CO01-KS)
AC Power Source	Chroma	61602	ABP000000 811	AC 0V~300V, 45Hz~1000Hz	Oct. 24, 2015	Aug. 20, 2016	Oct. 23, 2016	Conduction (CO01-KS)

NCR: No Calibration Required



## 5 Uncertainty of Evaluation

### Uncertainty of Conducted Emission Measurement (150 kHz ~ 30 MHz)

Measuring Uncertainty for a Level of Confidence of 95% (U = 2Uc(y))	2.3dB
---	-------

### For 03CH03-KS

### Uncertainty of Radiated Emission Measurement (30 MHz ~ 1000 MHz)

Measuring Uncertainty for a Level of Confidence of 95% (U = 2Uc(y))	4.5dB
---	-------

### Uncertainty of Radiated Emission Measurement (1GHz ~ 18GHz)

Measuring Uncertainty for a Level of Confidence of 95% (U = 2Uc(y))	4.5dB
---	-------

### Uncertainty of Radiated Emission Measurement (18GHz~40GHz)

Measuring Uncertainty for a Level of Confidence of 95% (U = 2Uc(y))	4.6dB
---	-------

### For 03CH02-KS

### Uncertainty of Radiated Emission Measurement (30 MHz ~ 1000 MHz)

Measuring Uncertainty for a Level of Confidence of 95% (U = 2Uc(y))	5.1dB
---	-------

### Uncertainty of Radiated Emission Measurement (1GHz ~ 18GHz)

Measuring Uncertainty for a Level of Confidence of 95% (U = 2Uc(y))	4.5dB
---	-------

### Uncertainty of Radiated Emission Measurement (18GHz~40GHz)

Measuring Uncertainty for a Level of Confidence of 95% (U = 2Uc(y))	5.1dB
---	-------





## **Appendix A. Conducted Test Results**

**Bluetooth v4.0 Low Energy**

Test Engineer:	Ivan Chen	Temperature:	24~25	°C
Test Date:	2016/8/14 ~ 2016/9/3	Relative Humidity:	54~55	%

**TEST RESULTS DATA**  
**6dB and 99% Occupied Bandwidth**

Mod.	Data Rate	NTX	CH.	Freq. (MHz)	99% Occupied BW (MHz)	6dB BW (MHz)	6dB BW Limit (MHz)	Pass/Fail
BLE	1Mbps	1	0	2402	1.05	0.67	0.50	Pass
BLE	1Mbps	1	19	2440	1.06	0.67	0.50	Pass
BLE	1Mbps	1	39	2480	1.05	0.67	0.50	Pass

**TEST RESULTS DATA**  
**Peak Power Table**

Mod.	Data Rate	NTX	CH.	Freq. (MHz)	Peak Conducted Power (dBm)	Conducted Power Limit (dBm)	DG (dBi)	EIRP Power (dBm)	EIRP Power Limit (dBm)	Pass /Fail
BLE	1Mbps	1	0	2402	-0.42	30.00	-4.93	-5.35	36.00	Pass
BLE	1Mbps	1	19	2440	0.42	30.00	-4.93	-4.51	36.00	Pass
BLE	1Mbps	1	39	2480	0.10	30.00	-4.93	-4.83	36.00	Pass

**TEST RESULTS DATA**  
**Average Power Table**  
**(Reporting Only)**

Mod.	Data Rate	NTX	CH.	Freq. (MHz)	Duty Factor (dB)	Average Conducted Power (dBm)
BLE	1Mbps	1	0	2402	2.05	-0.71
BLE	1Mbps	1	19	2440	2.05	0.06
BLE	1Mbps	1	39	2480	2.05	-0.26

**TEST RESULTS DATA**  
**Peak Power Density**

Mod.	Data Rate	NTX	CH.	Freq. (MHz)	Peak PSD (dBm /100kHz)	Peak PSD (dBm /3kHz)	DG (dBi)	Peak PSD Limit (dBm /3kHz)	Pass/Fail
BLE	1Mbps	1	0	2402	-1.48	-16.48	-4.93	8.00	Pass
BLE	1Mbps	1	19	2440	-0.42	-15.37	-4.93	8.00	Pass
BLE	1Mbps	1	39	2480	-0.73	-15.72	-4.93	8.00	Pass

Note: PSD (dBm/ 100kHz) is a reference level used for Conducted Band Edges and Conducted Spurious Emission 20dBc limit.

**Bluetooth v4.2 Low Energy**

Test Engineer:	Ivan Chen	Temperature:	24~25	°C
Test Date:	2016/8/14 ~ 2016/9/3	Relative Humidity:	54~55	%

**TEST RESULTS DATA**  
**6dB and 99% Occupied Bandwidth**

Mod.	Data Rate	NTX	CH.	Freq. (MHz)	99% Occupied BW (MHz)	6dB BW (MHz)	6dB BW Limit (MHz)	Pass/Fail
BLE	1Mbps	1	0	2402	1.05	0.67	0.50	Pass
BLE	1Mbps	1	19	2440	1.05	0.67	0.50	Pass
BLE	1Mbps	1	39	2480	1.05	0.68	0.50	Pass

**TEST RESULTS DATA**  
**Peak Power Table**

Mod.	Data Rate	NTX	CH.	Freq. (MHz)	Peak Conducted Power (dBm)	Conducted Power Limit (dBm)	DG (dBi)	EIRP Power (dBm)	EIRP Power Limit (dBm)	Pass /Fail
BLE	1Mbps	1	0	2402	-1.01	30.00	-4.93	-5.94	36.00	Pass
BLE	1Mbps	1	19	2440	-0.08	30.00	-4.93	-5.01	36.00	Pass
BLE	1Mbps	1	39	2480	0.16	30.00	-4.93	-4.77	36.00	Pass

**TEST RESULTS DATA**  
**Average Power Table**  
**(Reporting Only)**

Mod.	Data Rate	NTX	CH.	Freq. (MHz)	Duty Factor (dB)	Average Conducted Power (dBm)
BLE	1Mbps	1	0	2402	3.26	-1.13
BLE	1Mbps	1	19	2440	3.26	-0.29
BLE	1Mbps	1	39	2480	3.26	-0.03

**TEST RESULTS DATA**  
**Peak Power Density**

Mod.	Data Rate	NTX	CH.	Freq. (MHz)	Peak PSD (dBm /100kHz)	Peak PSD (dBm /3kHz)	DG (dBi)	Peak PSD Limit (dBm /3kHz)	Pass/Fail
BLE	1Mbps	1	0	2402	-0.98	-16.12	-4.93	8.00	Pass
BLE	1Mbps	1	19	2440	-0.04	-15.11	-4.93	8.00	Pass
BLE	1Mbps	1	39	2480	-0.74	-15.77	-4.93	8.00	Pass

Note: PSD (dBm/ 100kHz) is a reference level used for Conducted Band Edges and Conducted Spurious Emission 20dBc limit.



## Appendix B. Radiated Spurious Emission

2.4GHz 2400~2483.5MHz

BLE v4.0 (Band Edge @ 3m)

BLE	Note	Frequency	Level	Over	Limit	Read	Antenna	Cable	Preamp	Ant	Table	Peak	Pol.
		( MHz )	( dBμV/m )	( dB )	( dBμV/m )	( dBμV )	( dB/m )	( dB )	( dB )	( cm )	( deg )	( P/A )	( H/V )
BLE CH 00 2402MHz		2363.43	51.2	-22.8	74	55.88	26.91	5.43	37.02	295	126	P	H
		2385.79	40.72	-13.28	54	45.27	27	5.47	37.02	295	126	A	H
	*	2402.004	91.71	-	-	96.26	27	5.47	37.02	295	126	P	H
	*	2402.004	91.36	-	-	95.91	27	5.47	37.02	295	126	A	H
		2380.72	51.29	-22.71	74	55.91	26.95	5.45	37.02	100	102	P	V
		2357.45	40.58	-13.42	54	45.26	26.91	5.43	37.02	100	102	A	V
	*	2402.004	93.38	-	-	97.93	27	5.47	37.02	100	102	P	V
	*	2402.004	92.97	-	-	97.52	27	5.47	37.02	100	102	A	V
BLE CH 19 2440MHz	*	2439.997	92.61	-	-	96.7	27.39	5.49	36.97	368	132	P	H
	*	2439.997	92.19	-	-	96.28	27.39	5.49	36.97	368	132	A	H
	*	2439.746	93.98	-	-	98.07	27.39	5.49	36.97	100	101	P	V
	*	2439.997	93.34	-	-	97.43	27.39	5.49	36.97	100	101	A	V
BLE CH 39 2480MHz	*	2480.076	93.91	-	-	97.7	27.64	5.51	36.94	396	129	P	H
	*	2479.993	93.24	-	-	97.03	27.64	5.51	36.94	396	129	A	H
		2484.7	52.37	-21.63	74	56.16	27.64	5.51	36.94	396	129	P	H
		2483.5	42.52	-11.48	54	46.31	27.64	5.51	36.94	396	129	A	H
	*	2479.993	94.79	-	-	98.58	27.64	5.51	36.94	100	115	P	V
	*	2480.076	93.99	-	-	97.78	27.64	5.51	36.94	100	115	A	V
		2483.56	51.73	-22.27	74	55.52	27.64	5.51	36.94	100	115	P	V
		2483.5	42.44	-11.56	54	46.23	27.64	5.51	36.94	100	115	A	V
Remark	1. No other spurious found. 2. All results are PASS against Peak and Average limit line.												



2.4GHz 2400~2483.5MHz  
BLE v4.0 (Harmonic @ 3m)

BLE	Note	Frequency ( MHz )	Level ( dBμV/m )	Over Limit ( dB )	Limit Line ( dBμV/m )	Read Level ( dBμV )	Antenna Factor ( dB/m )	Cable Loss ( dB )	Preamp Factor ( dB )	Ant Pos ( cm )	Table Pos ( deg )	Peak Avg. ( P/A )	Pol. ( H/V )
BLE CH 00 2402MHz		4806	41.81	-32.19	74	39.31	31.48	7.71	36.69	100	0	P	H
		4806	42.96	-31.04	74	40.46	31.48	7.71	36.69	100	360	P	V
BLE CH 19 2440MHz		4878	42.99	-31.01	74	40.3	31.59	7.76	36.66	100	360	P	H
		7320	46.12	-27.88	74	38.97	34.08	9.78	36.71	100	360	P	H
		4878	42.67	-31.33	74	39.98	31.59	7.76	36.66	100	360	P	V
		7320	46.32	-27.68	74	39.17	34.08	9.78	36.71	100	360	P	V
BLE CH 39 2480MHz		4962	42.44	-31.56	74	39.53	31.72	7.82	36.63	100	360	P	H
		7440	46.26	-27.74	74	38.72	34.44	9.87	36.77	100	360	P	H
		4962	43.02	-30.98	74	40.11	31.72	7.82	36.63	100	360	P	V
		7440	45.32	-28.68	74	37.78	34.44	9.87	36.77	100	360	P	V
Remark	1. No other spurious found. 2. All results are PASS against Peak and Average limit line.												



Emission below 1GHz

2.4GHz BLE v4.0 (LF)

BLE	Note	Frequency	Level	Over	Limit	Read	Antenna	Cable	Preamp	Ant	Table	Peak	Pol.
		( MHz )	( dBμV/m )	( dB )	( dBμV/m )	( dBμV )	( dB/m )	( dB )	( dB )	( cm )	( deg )	( P/A )	( H/V )
2.4GHz BLE LF		34.85	26.14	-13.86	40	31.28	25.5	0.71	31.35	100	312	P	H
		120.21	19.57	-23.93	43.5	31.23	18.5	1.32	31.48	-	-	P	H
		166.77	18.74	-24.76	43.5	31.51	17.2	1.56	31.53	-	-	P	H
		216.24	20.29	-25.71	46	33.81	16.23	1.73	31.48	-	-	P	H
		457.77	26.56	-19.44	46	29.97	25.16	2.67	31.24	-	-	P	H
		896.21	31.61	-14.39	46	30.09	28.54	3.84	30.86	-	-	P	H
		30	26.35	-13.65	40	29.77	27.2	0.65	31.27	100	164	P	V
		100.81	18.7	-24.8	43.5	30.04	18.88	1.22	31.44	-	-	P	V
		152.22	19.19	-24.31	43.5	31.43	17.82	1.49	31.55	-	-	P	V
		306.45	23.65	-22.35	46	33.52	19.31	2.16	31.34	-	-	P	V
		323.91	26.63	-19.37	46	35.61	20.11	2.21	31.3	-	-	P	V
		448.07	26.84	-19.16	46	30.04	25.41	2.63	31.24	-	-	P	V
Remark	<ol style="list-style-type: none"> <li>No other spurious found.</li> <li>All results are PASS against limit line.</li> </ol>												



2.4GHz 2400~2483.5MHz

BLE v4.2 (Band Edge @ 3m)

BLE	Note	Frequency	Level	Over	Limit	Read	Antenna	Cable	Preamp	Ant	Table	Peak	Pol.
		( MHz )	( dBμV/m )	( dB )	Limit	Level	Factor	Loss	Factor	Pos	Pos	Avg.	
					Line	( dBμV )	( dB/m )	( dB )	( dB )	( cm )	( deg )	( P/A )	( H/V )
BLE CH 00 2402MHz		2336.65	49.81	-24.19	74	46.44	31.35	5.64	33.62	165	204	P	H
		2336.39	39.2	-14.8	54	35.83	31.35	5.64	33.62	165	204	A	H
	*	2402.254	87.53	-	-	83.78	31.4	5.56	33.21	165	204	P	H
	*	2401.92	87.25	-	-	83.5	31.4	5.56	33.21	165	204	A	H
		2365.77	49.13	-24.87	74	45.5	31.36	5.62	33.35	141	70	P	V
		2323.39	39.14	-14.86	54	35.79	31.33	5.64	33.62	141	70	A	V
	*	2402.254	90.6	-	-	86.85	31.4	5.56	33.21	141	70	P	V
	*	2402.004	90.23	-	-	86.48	31.4	5.56	33.21	141	70	A	V
BLE CH 19 2440MHz	*	2439.83	88.15	-	-	84.82	31.44	5.11	33.22	187	129	P	H
	*	2439.997	87.76	-	-	84.43	31.44	5.11	33.22	187	129	A	H
	*	2439.746	91.05	-	-	87.72	31.44	5.11	33.22	153	83	P	V
	*	2439.997	90.68	-	-	87.35	31.44	5.11	33.22	153	83	A	V
BLE CH 39 2480MHz	*	2480.243	87.75	-	-	84.66	31.47	4.88	33.26	258	129	P	H
	*	2480.076	87.44	-	-	84.35	31.47	4.88	33.26	258	129	A	H
		2485.48	47.69	-26.31	74	44.83	31.47	4.65	33.26	258	129	P	H
		2483.56	38.11	-15.89	54	35.25	31.47	4.65	33.26	258	129	A	H
	*	2480.243	89.73	-	-	86.64	31.47	4.88	33.26	121	78	P	V
	*	2479.993	89	-	-	85.91	31.47	4.88	33.26	121	78	A	V
		2492.5	47.39	-26.61	74	44.52	31.49	4.65	33.27	121	78	P	V
	2483.5	38.15	-15.85	54	35.06	31.47	4.88	33.26	121	78	A	V	
Remark	3. No other spurious found. 4. All results are PASS against Peak and Average limit line.												



2.4GHz 2400~2483.5MHz  
BLE v4.2 (Harmonic @ 3m)

BLE	Note	Frequency ( MHz )	Level ( dB $\mu$ V/m )	Over Limit ( dB )	Limit Line ( dB $\mu$ V/m )	Read Level ( dB $\mu$ V )	Antenna Factor ( dB/m )	Cable Loss ( dB )	Preamp Factor ( dB )	Ant Pos ( cm )	Table Pos ( deg )	Peak Avg. ( P/A )	Pol. ( H/V )
BLE CH 00 2402MHz		4806	43.19	-30.81	74	61.25	35	6.4	59.46	250	360	P	H
		4806	42.85	-31.15	74	60.91	35	6.4	59.46	250	360	P	V
BLE CH 19 2440MHz		4878	44.69	-29.31	74	62.47	34.93	6.43	59.14	150	360	P	H
		7320	47.95	-26.05	74	62.52	35.83	8.24	58.64	150	360	P	H
		4878	43.7	-30.3	74	61.48	34.93	6.43	59.14	250	0	P	V
		7320	46.99	-27.01	74	61.56	35.83	8.24	58.64	250	0	P	V
BLE CH 39 2480MHz		4962	44.7	-29.3	74	62.13	34.85	6.46	58.74	250	0	P	H
		7440	45.93	-28.07	74	60.99	35.88	8.3	59.24	250	0	P	H
		4960	44.32	-29.68	74	61.75	34.85	6.46	58.74	250	360	P	V
		7440	46.38	-27.62	74	61.44	35.88	8.3	59.24	250	360	P	V
Remark	3. No other spurious found. 4. All results are PASS against Peak and Average limit line.												





Emission below 1GHz

2.4GHz BLE v4.2 (LF)

BLE	Note	Frequency	Level	Over	Limit	Read	Antenna	Cable	Preamp	Ant	Table	Peak	Pol.
		( MHz )	( dBμV/m )	( dB )	( dBμV/m )	( dBμV )	( dB/m )	( dB )	( dB )	( cm )	( deg )	( P/A )	( H/V )
2.4GHz BLE LF		30.54	22.26	-17.74	40	28.1	25.8	0.11	31.75	100	210	P	H
		100.74	23	-20.5	43.5	35.94	18.3	0.24	31.48	-	-	P	H
		143.67	20.94	-22.56	43.5	34.47	17.68	0.31	31.52	-	-	P	H
		174.45	21.06	-22.44	43.5	35.79	16.5	0.37	31.6	-	-	P	H
		426	23.07	-22.93	46	27.34	24.88	0.93	30.08	-	-	P	H
		717.2	25.17	-20.83	46	25.49	26.58	1.24	28.14	-	-	P	H
		35.4	25.43	-14.57	40	32.76	24.3	0.12	31.75	100	132	P	V
		69.96	21.6	-18.4	40	39.94	13.2	0.18	31.72	-	-	P	V
		149.61	21.01	-22.49	43.5	34.62	17.6	0.32	31.53	-	-	P	V
		169.32	20.49	-23.01	43.5	34.87	16.68	0.36	31.42	-	-	P	V
		401.5	23.03	-22.97	46	27.35	25.27	0.93	30.52	-	-	P	V
		689.2	25.26	-20.74	46	25.94	26.48	1.14	28.3	-	-	P	V
Remark	3. No other spurious found. 4. All results are PASS against limit line.												



**Note symbol**

*	<b>Fundamental Frequency</b> which can be ignored. However, the level of any unwanted emissions shall not exceed the level of the fundamental frequency.
!	Test result is <b>over limit</b> line.
P/A	<b>Peak</b> or <b>Average</b>
H/V	<b>Horizontal</b> or <b>Vertical</b>



A calculation example for radiated spurious emission is shown as below:

WIFI	Note	Frequency	Level	Over	Limit	Read	Antenna	Cable	Preamp	Ant	Table	Peak	Pol.
Ant.				Limit	Line	Level	Factor	Loss	Factor	Pos	Pos	Avg.	
1+2		( MHz )	( dBμV/m )	( dB )	( dBμV/m )	( dBμV )	( dB/m )	( dB )	( dB )	( cm )	( deg )	( P/A )	( H/V )
802.11b		2390	55.45	-18.55	74	54.51	32.22	4.58	35.86	103	308	P	H
CH 01													
2412MHz		2390	43.54	-10.46	54	42.6	32.22	4.58	35.86	103	308	A	H

- Level(dBμV/m) =  
Antenna Factor(dB/m) + Cable Loss(dB) + Read Level(dBμV) - Preamp Factor(dB)
- Over Limit(dB) = Level(dBμV/m) – Limit Line(dBμV/m)

**For Peak Limit @ 2390MHz:**

- Level(dBμV/m)  
= Antenna Factor(dB/m) + Cable Loss(dB) + Read Level(dBμV) - Preamp Factor(dB)  
= 32.22(dB/m) + 4.58(dB) + 54.51(dBμV) – 35.86 (dB)  
= 55.45 (dBμV/m)
- Over Limit(dB)  
= Level(dBμV/m) – Limit Line(dBμV/m)  
= 55.45(dBμV/m) – 74(dBμV/m)  
= -18.55(dB)

**For Average Limit @ 2390MHz:**

- Level(dBμV/m)  
= Antenna Factor(dB/m) + Cable Loss(dB) + Read Level(dBμV) - Preamp Factor(dB)  
= 32.22(dB/m) + 4.58(dB) + 42.6(dBμV) – 35.86 (dB)  
= 43.54 (dBμV/m)
- Over Limit(dB)  
= Level(dBμV/m) – Limit Line(dBμV/m)  
= 43.54(dBμV/m) – 54(dBμV/m)  
= -10.46(dB)

Both peak and average measured complies with the limit line, so test result is “PASS”.



### Appendix C. Duty Cycle Plots

Band	Duty Cycle(%)	T(ms)	1/T(kHz)	VBW Setting
Bluetooth 4.0 LE	62.34	0.39	2.56	3kHz
Bluetooth 4.2 LE	47.22	0.30	3.38	10kHz

Bluetooth 4.0 LE

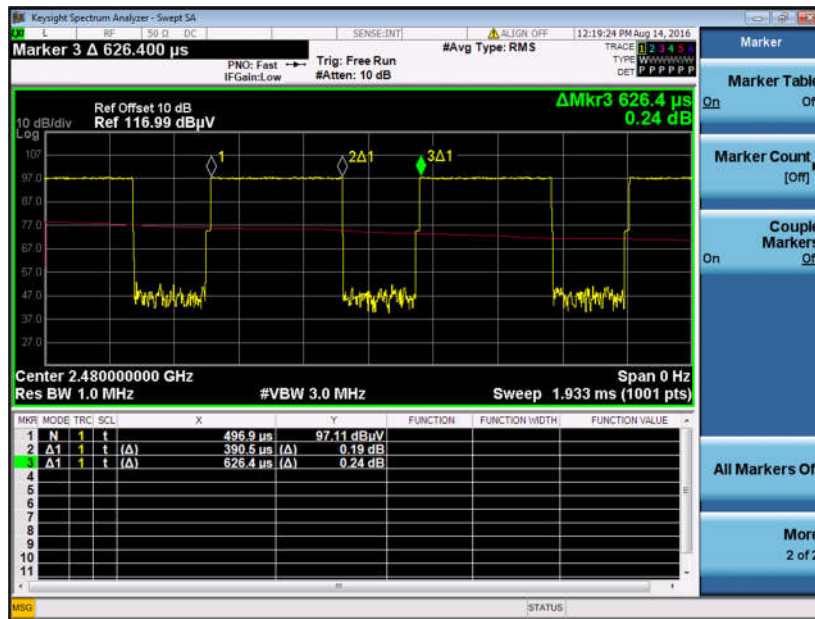



Bluetooth 4.2 LE

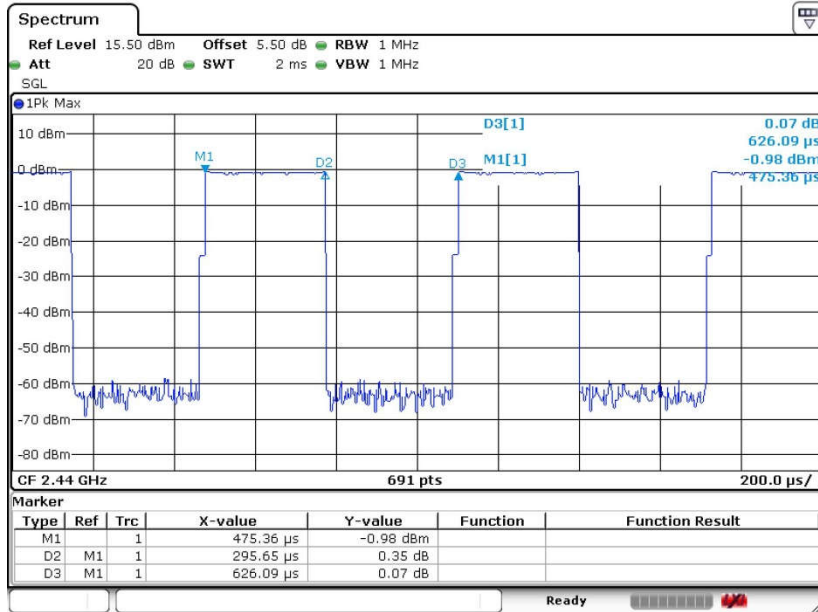

Date: 30.AUG.2016 15:48:24