



FCC RF Test Report

APPLICANT : Lenovo Mobile Communication Technology Ltd.
EQUIPMENT : Mobile Cellular Phone
BRAND NAME : Lenovo
MODEL NAME : Lenovo K53a48
FCC ID : YCNK53A48
STANDARD : FCC 47 CFR Part 2, 22(H), 24(E)
CLASSIFICATION : PCS Licensed Transmitter Held to Ear (PCE)

The product was received on Jun. 20, 2016 and testing was completed on Sep. 18, 2016. We, SPORTON INTERNATIONAL (KUNSHAN) INC., would like to declare that the tested sample has been evaluated in accordance with the test procedures given in ANSI / TIA / EIA-603-D-2010 and has been in compliance with the applicable technical standards.

The test results in this report apply exclusively to the tested model / sample. Without written approval of SPORTON INTERNATIONAL (KUNSHAN) INC., the test report shall not be reproduced except in full.

Prepared by: James Huang / Manager



Approved by: Jones Tsai / Manager

SPORTON INTERNATIONAL (KUNSHAN) INC.
No. 3-2, PingXiang Road, Kunshan, Jiangsu Province, P. R. China



TABLE OF CONTENTS

REVISION HISTORY.....3

SUMMARY OF TEST RESULT4

1 GENERAL DESCRIPTION5

1.1. Applicant.....5

1.2. Manufacturer5

1.3. Product Feature of Equipment Under Test5

1.4. Product Specification of Equipment Under Test6

1.5. Specification of Accessory7

1.6. Modification of EUT7

1.7. Maximum ERP/EIRP Power, Frequency Tolerance, and Emission Designator8

1.8. Testing Location8

1.9. Applicable Standards8

2 TEST CONFIGURATION OF EQUIPMENT UNDER TEST9

2.1 Test Mode.....9

2.2 Connection Diagram of Test System10

2.3 Support Unit used in test configuration10

2.4 Measurement Results Explanation Example11

3 CONDUCTED TEST RESULT.....12

3.1 Measuring Instruments.....12

3.2 Test Setup12

3.3 Test Result of Conducted Test.....12

3.4 Conducted Output Power13

3.5 Peak-to-Average Ratio13

3.6 99% Occupied Bandwidth and 26dB Bandwidth Measurement.....14

3.7 Conducted Band Edge15

3.8 Conducted Spurious Emission16

3.9 Frequency Stability.....17

4 RADIATED TEST ITEMS18

4.1 Measuring Instruments.....18

4.2 Test Setup18

4.3 Test Result of Radiated Test.....18

4.4 Effective Radiated Power and Effective Isotropic Radiated Power Measurement19

4.5 Field Strength of Spurious Radiation Measurement21

5 LIST OF MEASURING EQUIPMENT22

6 UNCERTAINTY OF EVALUATION23

APPENDIX A. TEST RESULTS OF CONDUCTED TEST

APPENDIX B. TEST RESULTS OF RADIATED TEST

APPENDIX C. TEST SETUP PHOTOGRAPHS



REVISION HISTORY

REPORT NO.	VERSION	DESCRIPTION	ISSUED DATE
FG662003A	Rev. 01	Initial issue of report	Sep. 23, 2016



SUMMARY OF TEST RESULT

Report Section	FCC Rule	Description	Limit	Result	Remark
3.4	§2.1046	Conducted Output Power	Reporting Only	PASS	-
3.5	§24.232(d)	Peak-to-Average Ratio	< 13 dB	PASS	-
3.6	§2.1049 §22.917(b) §24.238(b)	Occupied Bandwidth	Reporting Only	PASS	-
3.7	§2.1051 §22.917(a) §24.238(a)	Band Edge Measurement	< 43+10log10(P[Watts])	PASS	-
3.8	§2.1051 §22.917(a) §24.238(a)	Conducted Emission	< 43+10log10(P[Watts])	PASS	-
3.9	§2.1055 §22.355	Frequency Stability for Temperature & Voltage	< 2.5 ppm	PASS	-
	§2.1055 §24.235		Within Authorized Band		
4.4	§22.913(a)(2)	Effective Radiated Power	< 7 Watts	PASS	-
	§24.232(c)	Equivalent Isotropic Radiated Power	< 2 Watts	PASS	-
4.5	§2.1053 §22.917(a) §24.238(a)	Field Strength of Spurious Radiation	< 43+10log10(P[Watts])	PASS	Under limit 31.72 dB at 1672.000 MHz



1 General Description

1.1. Applicant

Lenovo Mobile Communication Technology Ltd.

No.999, Qishan North 2nd Road, Information & Optoelectronics Park, Torch Hi-tech Industry Development Zone, Xiamen, P.R.China

1.2. Manufacturer

Motorola Mobility LLC

222 W, Merchandise Mart Plaza, Chicago IL 60654 USA

1.3. Product Feature of Equipment Under Test

Product Feature	
Equipment	Mobile Cellular Phone
Brand Name	Lenovo
Model Name	Lenovo K53a48
FCC ID	YCNK53A48
EUT supports Radios application	GSM/GPRS/EGPRS/WCDMA/HSPA/DC-HSDPA HSPA+(16QAM uplink is not supported)/LTE/ WLAN2.4GHz 802.11b/g/n HT20/ Bluetooth v3.0 + EDR/Bluetooth v4.0 LE/Bluetooth v4.2 LE
IMEI Code	Conducted: 861576030071119/861576030071127 Radiation: 861576030071572/861576030071580 ERP&EIRP: 861886030041651/861886030041669
HW Version	82939_1_13
SW Version	K53_S022_160815_ROW
EUT Stage	Identical Prototype

Remark: The above EUT's information was declared by manufacturer. Please refer to the specifications or user's manual for more detailed description.



1.4. Product Specification of Equipment Under Test

Standards-related Product Specification	
Tx Frequency	GSM/GPRS/EDGE: 850: 824.2 MHz ~ 848.8 MHz 1900: 1850.2 MHz ~ 1909.8MHz WCDMA: Band V: 826.4 MHz ~ 846.6 MHz Band II: 1852.4 MHz ~ 1907.6 MHz
Rx Frequency	GSM/GPRS/EDGE: 850: 869.2 MHz ~ 893.8 MHz 1900: 1930.2 MHz ~ 1989.8 MHz WCDMA: Band V: 871.4 MHz ~ 891.6 MHz Band II: 1932.4 MHz ~ 1987.6 MHz
Maximum Output Power to Antenna	GSM/GPRS/EDGE: 850: 33.95 dBm 1900: 30.81 dBm WCDMA: Band V: 24.45 dBm Band II: 23.37 dBm
Antenna Type	PIFA Antenna
Type of Modulation	GSM: GMSK GPRS: GMSK EDGE: GMSK / 8PSK WCDMA: BPSK (Uplink) HSDPA/DC-HSDPA: QPSK (Uplink) HSUPA: QPSK (Uplink) DC-HSDPA: 64QAM HSPA+ : 16QAM (uplink is not supported)

1.5. Specification of Accessory

Specification of Accessory			
AC Adapter 1	Brand Name	Lenovo (Acbel)	Model Name C-P35
	Power Rating	I/P: 100-240Vac, 300mA, O/P: 5.2Vdc, 2000mA	
AC Adapter 2	Brand Name	Lenovo (Huntkey)	Model Name C-P35
	Power Rating	I/P: 100-240Vac, 500mA, O/P: 5.2Vdc, 2000mA	
Battery	Brand Name	Lenovo (SCUD)	Model Name BL270
	Power Rating	3.85Vdc, 4000mAh	
Earphone	Brand Name	N/A	Model Name NLD-EM127E-96SH-6
	Signal Line Type	1.1 meter, non-shielded cable, without ferrite core	
USB Cable	Brand Name	Lenovo(Starw)	Model Name XJ-007070
	Signal Line Type	1.0 meter, non-shielded cable, without ferrite core	
LCD Panel	Brand Name	TIANMA	Model Name TL055VDXP64-00
Camera_ Front	Brand Name	Q-Tech	Model Name FX219BQS
Camera _ Rear	Brand Name	Sunny	Model Name A16S05J-200
CTP Module	Brand Name	O-FILM	Model Name Black : MCF-055-2594 White : MCF-055-2594-01 Golden : MCF-055-2594-02

1.6. Modification of EUT

No modifications are made to the EUT during all test items.



1.7. Maximum ERP/EIRP Power, Frequency Tolerance, and Emission Designator

FCC Rule	System	Type of Modulation	Maximum ERP/EIRP (W)	Frequency Tolerance (ppm)	Emission Designator
Part 22H	GSM850 GSM	GMSK	0.4677	0.0155 ppm	243KGXW
Part 22H	GSM850 EDGE class 8	8PSK	0.0931	0.0096 ppm	243KG7W
Part 22H	WCDMA Band V RMC 12.2Kbps	BPSK	0.0804	0.0167 ppm	4M13F9W
Part 24E	GSM1900 GSM	GMSK	0.7745	0.0160 ppm	244KGXW
Part 24E	GSM1900 EDGE class 8	8PSK	0.2466	0.0160 ppm	248KG7W
Part 24E	WCDMA Band II RMC 12.2Kbps	BPSK	0.1786	0.0074 ppm	4M12F9W

1.8. Testing Location

Test Site	SPORTON INTERNATIONAL (KUNSHAN) INC.		
Test Site Location	No. 3-2, PingXiang Road, Kunshan, Jiangsu Province, P. R. China TEL: +86-0512-5790-0158 FAX: +86-0512-5790-0958		
Test Site No.	Sporton Site No.		FCC Registration No.
	TH01-KS	03CH02-KS	418269

Note: The test site complies with ANSI C63.4 2014 requirement.

1.9. Applicable Standards

According to the specifications of the manufacturer, the EUT must comply with the requirements of the following standards:

- 47 CFR Part 2, 22(H), 24(E)
- ANSI / TIA / EIA-603-D-2010
- FCC KDB 971168 D01 Power Meas. License Digital Systems v02r02

Remark:

1. All test items were verified and recorded according to the standards and without any deviation during the test.
2. This EUT has also been tested and complied with the requirements of FCC Part 15, Subpart B, recorded in a separate test report.



2 Test Configuration of Equipment Under Test

2.1 Test Mode

Antenna port conducted and radiated test items were performed according to KDB 971168 D01 Power Meas. License Digital Systems v02r02 with maximum output power.

Radiated measurements were performed with rotating EUT in different three orthogonal test planes to find the maximum emission.

Radiated emissions were investigated from 30 MHz to 10th harmonic.

All modes and data rates and positions were investigated.

Test modes are chosen to be reported as the worst case configuration below:

Test Modes		
Band	Radiated TCs	Conducted TCs
GSM 850	<ul style="list-style-type: none">■ GSM Link■ EDGE class 8 Link	<ul style="list-style-type: none">■ GSM Link■ EDGE class 8 Link
GSM 1900	<ul style="list-style-type: none">■ GSM Link■ EDGE class 8 Link	<ul style="list-style-type: none">■ GSM Link■ EDGE class 8 Link
WCDMA Band V	<ul style="list-style-type: none">■ RMC 12.2Kbps Link	<ul style="list-style-type: none">■ RMC 12.2Kbps Link
WCDMA Band II	<ul style="list-style-type: none">■ RMC 12.2Kbps Link	<ul style="list-style-type: none">■ RMC 12.2Kbps Link

2.2 Connection Diagram of Test System

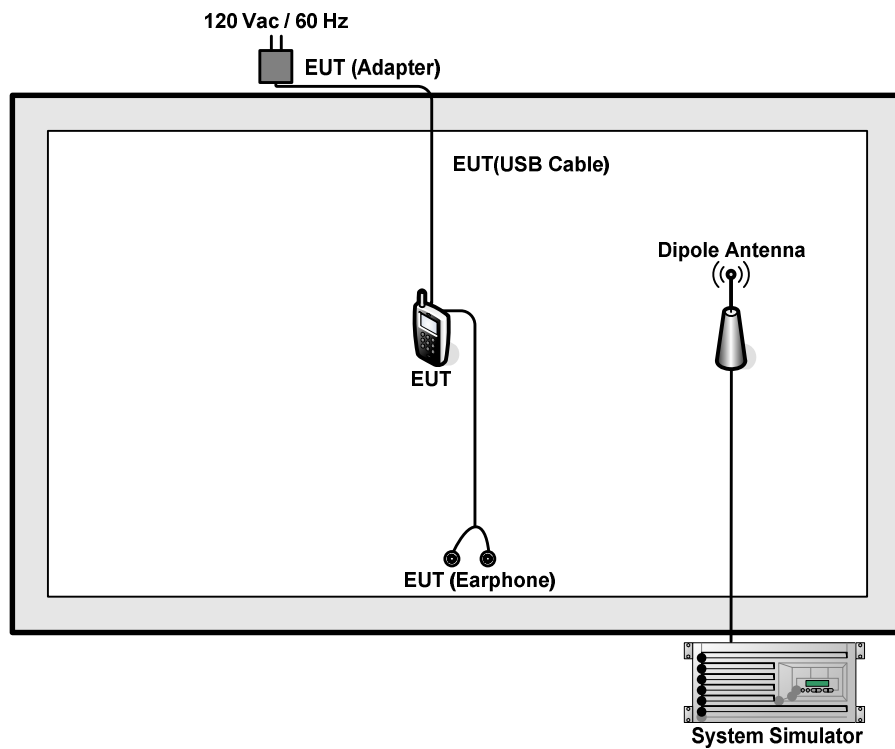

2.3 Support Unit used in test configuration

Item	Equipment	Trade Name	Model No.	FCC ID	Data Cable	Power Cord
1.	System Simulator	Anritus	MT8820C	N/A	N/A	Unshielded, 1.8 m
2.	DC Power Supply	GW INSTRON	GPD-2303S	N/A	N/A	Unshielded, 1.8 m



2.4 Measurement Results Explanation Example

For all conducted test items:

The offset level is set in the spectrum analyzer to compensate the RF cable loss and attenuator factor between RF conducted output port and spectrum analyzer. With the offset compensation, the spectrum analyzer reading level will be exactly the RF output level.

The spectrum analyzer offset is derived from RF cable loss and attenuator factor.

Offset = RF cable loss + attenuator factor.

The following shows an offset computation example with RF cable loss 4.5 dB and a 10dB attenuator.

Example :

$$\begin{aligned} \text{Offset(dB)} &= \text{RF cable loss(dB)} + \text{attenuator factor(dB)}. \\ &= 4.5 + 10 = 14.5(\text{dB}) \end{aligned}$$

3 Conducted Test Result

3.1 Measuring Instruments

See list of measuring instruments of this test report.

3.2 Test Setup

3.2.1 Conducted Output Power



3.2.2 Peak-to-Average Ratio, Occupied Bandwidth, Conducted Band-Edge and Conducted Spurious Emission

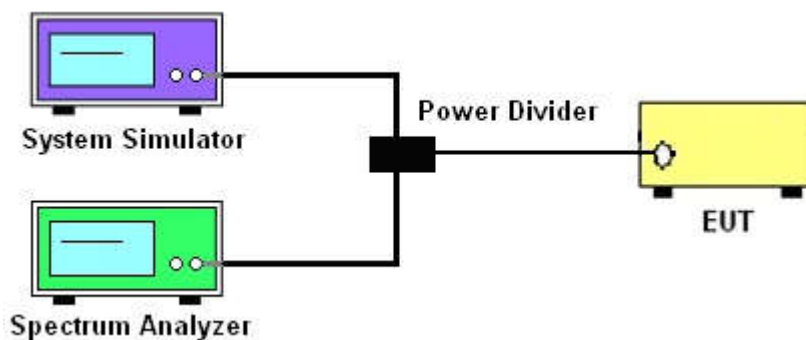

3.2.3 Frequency Stability

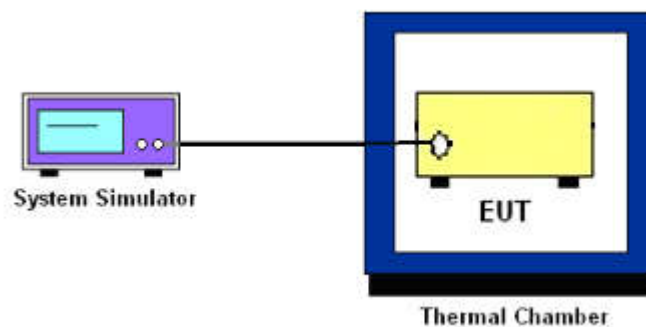

3.3 Test Result of Conducted Test

Please refer to Appendix A.



3.4 Conducted Output Power

3.4.1 Description of the Conducted Output Power

A system simulator was used to establish communication with the EUT. Its parameters were set to enforce EUT transmitting at the maximum power. The measured power in the radio frequency on the transmitter output terminals shall be reported.

3.4.2 Test Procedures

1. The transmitter output port was connected to the system simulator.
2. Set EUT at maximum power through system simulator.
3. Select lowest, middle, and highest channels for each band and different modulation.
4. Measure the maximum burst average power for GSM and maximum average power for other modulation signal.

3.5 Peak-to-Average Ratio

3.5.1 Description of the PAR Measurement

The peak-to-average ratio (PAR) of the transmission may not exceed 13 dB.

3.5.2 Test Procedures

1. The testing follows FCC KDB 971168 D01 v02r02 Section 5.7.1.
2. The EUT was connected to spectrum analyzer and system simulator via a power divider.
3. Set EUT to transmit at maximum output power.
4. When the duty cycle is less than 98%, then signal gating will be implemented on the spectrum analyzer by triggering from the system simulator.
5. Set the CCDF (Complementary Cumulative Distribution Function) option of the spectrum analyzer. Record the maximum PAPR level associated with a probability of 0.1%.



3.6 99% Occupied Bandwidth and 26dB Bandwidth Measurement

3.6.1 Description of 99% Occupied Bandwidth and 26dB Bandwidth Measurement

The occupied bandwidth is the width of a frequency band such that, below the lower and above the upper frequency limits, the mean powers emitted are each equal to a specified percentage 0.5% of the total mean transmitted power.

The 26 dB emission bandwidth is defined as the frequency range between two points, one above and one below the carrier frequency, at which the spectral density of the emission is attenuated 26 dB below the maximum in-band spectral density of the modulated signal. Spectral density (power per unit bandwidth) is to be measured with a detector of resolution bandwidth equal to approximately 1.0% of the emission bandwidth.

3.6.2 Test Procedures

1. The testing follows FCC KDB 971168 v02r02 Section 4.2.
2. The EUT was connected to spectrum analyzer and system simulator via a power divider.
3. The spectrum analyzer center frequency is set to the nominal EUT channel center frequency. The span range for the spectrum analyzer shall be between two and five times the anticipated OBW.
4. The nominal resolution bandwidth (RBW) shall be in the range of 1 to 5 % of the anticipated OBW, and the VBW shall be at least 3 times the RBW.
5. Set the detection mode to peak, and the trace mode to max hold.
6. Determine the reference value: Set the EUT to transmit a modulated signal. Allow the trace to stabilize. Set the spectrum analyzer marker to the highest level of the displayed trace.
(this is the reference value)
7. Determine the “-26 dB down amplitude” as equal to (Reference Value – X).
8. Place two markers, one at the lowest and the other at the highest frequency of the envelope of the spectral display such that each marker is at or slightly below the “-X dB down amplitude” determined in step 6. If a marker is below this “-X dB down amplitude” value it shall be placed as close as possible to this value. The OBW is the positive frequency difference between the two markers.
9. Use the 99 % power bandwidth function of the spectrum analyzer and report the measured bandwidth.



3.7 Conducted Band Edge

3.7.1 Description of Conducted Band Edge Measurement

The power of any emission outside of the authorized operating frequency ranges must be lower than the transmitter power (P) by a factor of at least $43 + 10 \log (P)$ dB.

3.7.2 Test Procedures

1. The testing follows FCC KDB 971168 D01 v02r02 Section 6.0.
2. The EUT was connected to the spectrum analyzer and system simulator via a power divider.
3. The RF output of EUT was connected to the spectrum analyzer by an RF cable and attenuator. The path loss was compensated to the results for each measurement.
4. The band edges of low and high channels for the highest RF powers were measured.
5. The RF fundamental frequency should be excluded against the limit line in the operating frequency band.
6. The limit line is derived from $43 + 10\log(P)$ dB below the transmitter power P(Watts)
= $P(W) - [43 + 10\log(P)]$ (dB)
= $[30 + 10\log(P)]$ (dBm) - $[43 + 10\log(P)]$ (dB)
= -13dBm.



3.8 Conducted Spurious Emission

3.8.1 Description of Conducted Spurious Emission Measurement

The power of any emission outside of the authorized operating frequency ranges must be lower than the transmitter power (P) by a factor of at least $43 + 10 \log (P)$ dB.

It is measured by means of a calibrated spectrum analyzer and scanned from 30 MHz up to a frequency including its 10th harmonic.

3.8.2 Test Procedures

1. The testing follows FCC KDB 971168 D01 v02r02 Section 6.0.
2. The EUT was connected to the spectrum analyzer and system simulator via a power divider.
3. The RF output of EUT was connected to the spectrum analyzer by an RF cable and attenuator. The path loss was compensated to the results for each measurement.
4. The middle channel for the highest RF power within the transmitting frequency was measured.
5. The conducted spurious emission for the whole frequency range was taken.
6. The RF fundamental frequency should be excluded against the limit line in the operating frequency band.
7. The limit line is derived from $43 + 10\log(P)$ dB below the transmitter power P(Watts)
= $P(W) - [43 + 10\log(P)]$ (dB)
= $[30 + 10\log(P)]$ (dBm) - $[43 + 10\log(P)]$ (dB)
= -13dBm.



3.9 Frequency Stability

3.9.1 Description of Frequency Stability Measurement

The frequency stability shall be measured by variation of ambient temperature and variation of primary supply voltage to ensure that the fundamental emission stays within the authorized frequency block. The frequency stability of the transmitter shall be maintained within $\pm 0.00025\%$ ($\pm 2.5\text{ppm}$) of the center frequency.

3.9.2 Test Procedures for Temperature Variation

1. The testing follows FCC KDB 971168 D01 v02r02 Section 9.0.
2. The EUT was set up in the thermal chamber and connected with the system simulator.
3. With power OFF, the temperature was decreased to -30°C and the EUT was stabilized before testing. Power was applied and the maximum change in frequency was recorded within one minute.
4. With power OFF, the temperature was raised in 10°C steps up to 50°C . The EUT was stabilized at each step for at least half an hour. Power was applied and the maximum frequency change was recorded within one minute.

3.9.3 Test Procedures for Voltage Variation

1. The testing follows FCC KDB 971168 D01 v02r02 Section 9.0.
2. The EUT was placed in a temperature chamber at $20\pm 5^{\circ}\text{C}$ and connected with the system simulator.
3. The power supply voltage to the EUT was varied from 85% to 115% of the nominal value measured at the input to the EUT.
4. The variation in frequency was measured for the worst case.

4 Radiated Test Items

4.1 Measuring Instruments

See list of measuring instruments of this test report.

4.2 Test Setup

4.2.1 For radiated test from 30MHz to 1GHz

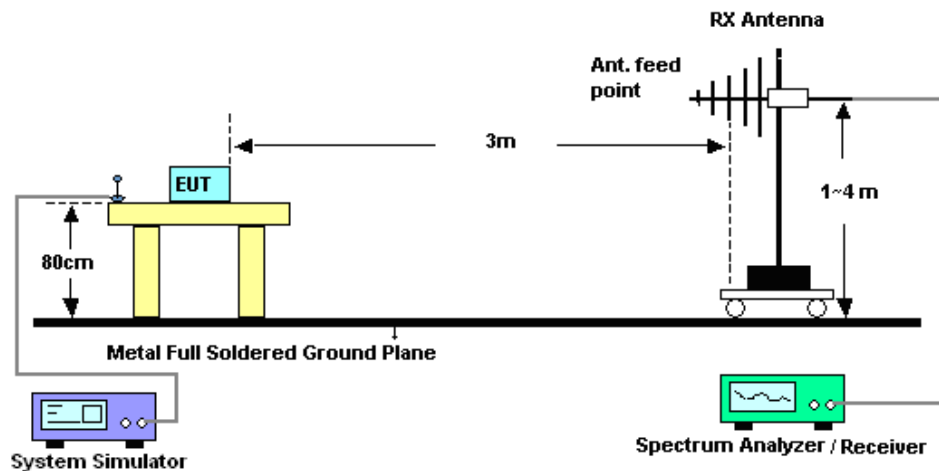

4.2.2 For radiated test above 1GHz

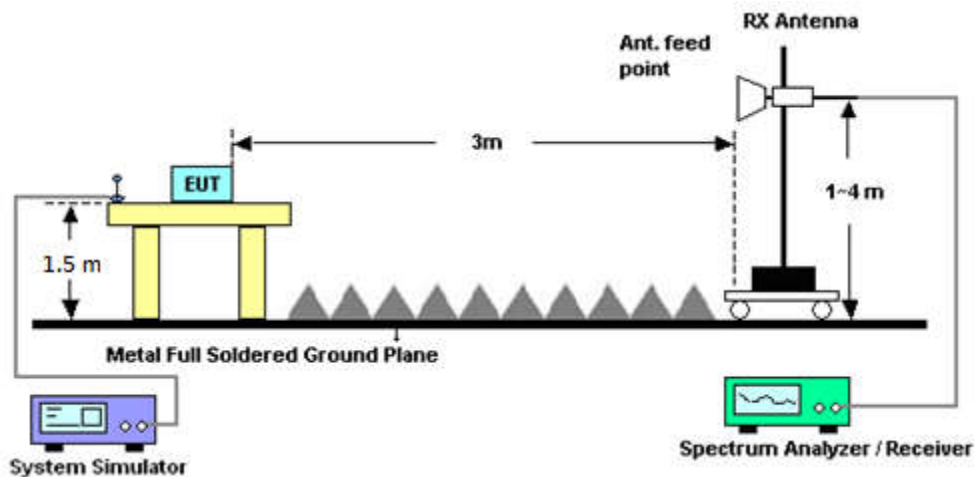

4.3 Test Result of Radiated Test

Please refer to Appendix B.



4.4 Effective Radiated Power and Effective Isotropic Radiated Power Measurement

4.4.1 Description of the ERP/EIRP Measurement

The substitution method, in ANSI / TIA / EIA-603-D-2010, was used for ERP/EIRP measurement, and the spectrum analyzer configuration follows KDB 971168 D01 Power Meas. License Digital Systems v02r02. The ERP of mobile transmitters must not exceed 7 Watts (Cellular Band) and the EIRP of mobile transmitters are limited to 2 Watts (PCS Band)

4.4.2 Test Procedures

1. The testing follows FCC KDB 971168 D01 v02r02 Section 5.2.1. (for CDMA/WCDMA), Section 5.2.2.2 (for GSM/GPRS/EDGE) and ANSI / TIA-603-D-2010 Section 2.2.17.
2. The EUT was placed on a non-conductive rotating platform (0.8 meters for frequency below 1GHz and 1.5 meter for frequency above 1GHz) in a semi-anechoic chamber. The radiated emission at the fundamental frequency was measured at 3 m with a test antenna and a spectrum analyzer with RMS detector per section 5. of KDB 971168 D01.
3. During the measurement, the system simulator parameters were set to force the EUT transmitting at maximum output power. The maximum emission was recorded from analyzer power level (LVL) from the 360 degrees rotation of the turntable and the test antenna raised and lowered over a range from 1 to 4 meters in both horizontally and vertically polarized orientations.
4. Effective Isotropic Radiated Power (EIRP) was measured by substitution method according to TIA/EIA-603-D. The EUT was replaced by the substitution antenna at same location, and then a known power from S.G. was applied into the dipole antenna through a Tx cable, and then recorded the maximum Analyzer reading through raised and lowered the test antenna. The correction factor (in dB) = S.G. - Tx Cable loss + Substitution antenna gain - Analyzer reading. Then the EUT's EIRP was calculated with the correction factor, $EIRP = LVL + \text{Correction factor}$ and $ERP = EIRP - 2.15$. Take the record of the output power at substitution antenna.



	GSM/GPRS/EDGE	WCDMA/HSPA
SPAN	500kHz	10MHz
RBW	10kHz	100kHz
VBW	30kHz	300kHz
Detector	RMS	RMS
Trace	Average	Average
Average Type	Power	Power
Sweep Count	100	100



4.5 Field Strength of Spurious Radiation Measurement

4.5.1 Description of Field Strength of Spurious Radiated Measurement

The power of any emission outside of the authorized operating frequency ranges must be attenuated below the transmitter power (P) by a factor of at least $43 + 10 \log (P)$ dB. The spectrum is scanned from 30 MHz up to a frequency including its 10th harmonic.

4.5.2 Test Procedures

1. The testing follows FCC KDB 971168 D01 v02r02 Section 5.8 and ANSI / TIA-603-D-2010 Section 2.2.12.
2. The EUT was placed on a rotatable wooden table 0.8 meters for frequency below 1GHz and 1.5 meter for frequency above 1GHz above the ground.
3. The EUT was set 3 meters from the receiving antenna, which was mounted on the antenna tower.
4. The table was rotated 360 degrees to determine the position of the highest spurious emission.
5. The height of the receiving antenna is varied between one meter and four meters to search for the maximum spurious emission for both horizontal and vertical polarizations.
6. Make the measurement with the spectrum analyzer's RBW = 1MHz, VBW = 3MHz, taking record of maximum spurious emission.
7. A horn antenna was substituted in place of the EUT and was driven by a signal generator.
8. Tune the output power of signal generator to the same emission level with EUT maximum spurious emission.
9. Taking the record of output power at antenna port.
10. Repeat step 7 to step 8 for another polarization.
11. $EIRP \text{ (dBm)} = S.G. \text{ Power} - Tx \text{ Cable Loss} + Tx \text{ Antenna Gain}$
12. $ERP \text{ (dBm)} = EIRP - 2.15$
13. The RF fundamental frequency should be excluded against the limit line in the operating frequency band.
14. The limit line is derived from $43 + 10\log(P)$ dB below the transmitter power P(Watts)
 $= P(W) - [43 + 10\log(P)] \text{ (dB)}$
 $= [30 + 10\log(P)] \text{ (dBm)} - [43 + 10\log(P)] \text{ (dB)}$
 $= -13dBm.$



5 List of Measuring Equipment

Instrument	Manufacturer	Model No.	Serial No.	Characteristics	Calibration Date	Test Date	Due Date	Remark
Spectrum Analyzer	R&S	FSV40	101040	10Hz~40GHz	Aug. 09, 2016	Sep. 15, 2016~ Sep. 18, 2016	Aug. 08, 2017	Conducted (TH01-KS)
Thermal Chamber	Ten Billion	TTC-B3S	TBN-960502	-40~+150°C	Oct. 24, 2015	Sep. 15, 2016~ Sep. 18, 2016	Oct. 23, 2016	Conducted (TH01-KS)
EXA Spectrum Analyzer	Keysight	N9010A	MY55150208	10Hz~44GHz; Max 30dB	Apr. 22, 2016	Aug. 24, 2016	Apr. 21, 2017	Radiation (03CH02-KS)
Bilog Antenna	TeseQ	CBL6112D	37879	30MHz~2GHz	Sep. 12, 2015	Aug. 24, 2016	Sep. 11, 2016	Radiation (03CH02-KS)
Double Ridge Horn Antenna	ETS-Lindgren	3117	75957	1GHz~18GHz	Nov. 07, 2015	Aug. 24, 2016	Nov. 06, 2016	Radiation (03CH02-KS)
SHF-EHF Horn	Schwarzbeck	BBHA 9170	BBHA170249	15GHz~40GHz	Mar. 03, 2016	Aug. 24, 2016	Mar. 02, 2017	Radiation (03CH02-KS)
Amplifier	com-power	PA-103A	161069	1kHz~1000MHz / 32 dB	Apr. 22, 2016	Aug. 24, 2016	Apr. 21, 2017	Radiation (03CH02-KS)
High Gain Amplifier	MITEQ	AMF-7D-00 101800-30-1 0P	1865802	1GHz~18GHz	Jan. 20, 2016	Aug. 24, 2016	Jan. 19, 2017	Radiation (03CH02-KS)
Amplifier	Agilent	8449B	3008A02384	1~26.5GHz Gain 30dB	Oct. 24, 2015	Aug. 24, 2016	Oct. 23, 2016	Radiation (03CH02-KS)
Amplifier	MITEQ	TTA1840-35 -HG	1887435	18GHz~40GHz	Jan. 20, 2016	Aug. 24, 2016	Jan. 19, 2017	Radiation (03CH02-KS)
AC Power Source	Chroma	61601	61601000247 3	N/A	NCR	Aug. 24, 2016	NCR	Radiation (03CH02-KS)
Turn Table	MF	MF7802	N/A	0~360 degree	NCR	Aug. 24, 2016	NCR	Radiation (03CH02-KS)
Antenna Mast	MF	MF7802	N/A	1 m~4 m	NCR	Aug. 24, 2016	NCR	Radiation (03CH02-KS)

NCR: No Calibration Required



6 Uncertainty of Evaluation

Uncertainty of Radiated Emission Measurement (30 MHz ~ 1000 MHz)

Measuring Uncertainty for a Level of Confidence of 95% ($U = 2Uc(y)$)	5.1 dB
---	--------

Uncertainty of Radiated Emission Measurement (1 GHz ~ 18 GHz)

Measuring Uncertainty for a Level of Confidence of 95% ($U = 2Uc(y)$)	4.5 dB
---	--------

Uncertainty of Radiated Emission Measurement (18 GHz ~ 40 GHz)

Measuring Uncertainty for a Level of Confidence of 95% ($U = 2Uc(y)$)	5.1 dB
---	--------



Appendix A. Test Results of Conducted Test

Conducted Output Power(Average power)

Conducted Power (*Unit: dBm)						
Band	GSM850			GSM1900		
Channel	128	189	251	512	661	810
Frequency	824.2	836.4	848.8	1850.2	1880.0	1909.8
GSM	33.53	33.71	33.95	30.46	30.51	30.81
GPRS class 8	33.51	33.70	33.93	30.44	30.48	30.79
GPRS class 10	31.66	31.44	31.59	29.38	29.46	29.61
GPRS class 11	30.41	30.20	30.31	28.14	28.19	28.38
GPRS class 12	28.97	28.90	29.17	26.74	26.82	27.00
EGPRS class 8	25.19	25.03	25.01	24.85	24.55	24.51
EGPRS class 10	24.05	23.96	23.91	23.69	23.41	23.36
EGPRS class 11	22.87	22.77	22.79	22.51	22.25	22.14
EGPRS class 12	21.88	21.70	21.71	21.26	21.00	20.95

Conducted Power (*Unit: dBm)						
Band	WCDMA Band V			WCDMA Band II		
Channel	4132	4182	4233	9262	9400	9538
Frequency	826.4	836.4	846.6	1852.4	1880	1907.6
AMR12.2Kbps	24.32	24.30	24.44	23.21	23.27	23.36
RMC 12.2Kbps	24.35	24.31	24.45	23.23	23.28	23.37
HSDPA Subtest-1	23.44	23.52	23.59	22.55	22.80	22.64
HSDPA Subtest-2	23.38	23.46	23.65	22.80	23.00	22.90
HSDPA Subtest-3	22.99	22.99	23.18	22.29	22.50	22.44
HSDPA Subtest-4	22.97	22.98	23.18	22.30	22.39	22.45
DC-HSDPA Subtest-1	23.34	23.44	23.56	22.53	22.80	22.60
DC-HSDPA Subtest-2	23.34	23.36	23.56	22.79	22.97	22.89
DC-HSDPA Subtest-3	22.92	22.91	23.15	22.25	22.41	22.39
DC-HSDPA Subtest-4	22.92	22.95	23.16	22.26	22.35	22.41
HSUPA Subtest-1	22.77	22.88	23.07	22.78	22.35	22.58
HSUPA Subtest-2	22.16	22.44	22.66	21.58	21.59	21.40
HSUPA Subtest-3	22.07	22.19	22.22	20.79	21.92	21.30
HSUPA Subtest-4	22.63	22.57	22.66	22.06	21.99	22.27
HSUPA Subtest-5	23.40	23.50	23.80	22.70	22.90	22.80



Peak-to-Average Ratio

Mode	GSM850(dB)		Limit: 13dB
Mod.	GSM	EDGE class 8	Result
Lowest CH	0.23	3.33	PASS
Middle CH	0.17	3.51	
Highest CH	0.23	3.33	

Mode	GSM1900(dB)		Limit: 13dB
Mod.	GSM	EDGE class 8	Result
Lowest CH	0.38	3.54	PASS
Middle CH	0.35	3.36	
Highest CH	0.35	3.71	

Mode	WCDMA Band V(dB)	WCDMA Band II(dB)	Limit: 13dB
Mod.	RMC 12.2Kbps	RMC 12.2Kbps	Result
Lowest CH	3.04	3.39	PASS
Middle CH	2.99	3.51	
Highest CH	3.19	3.68	

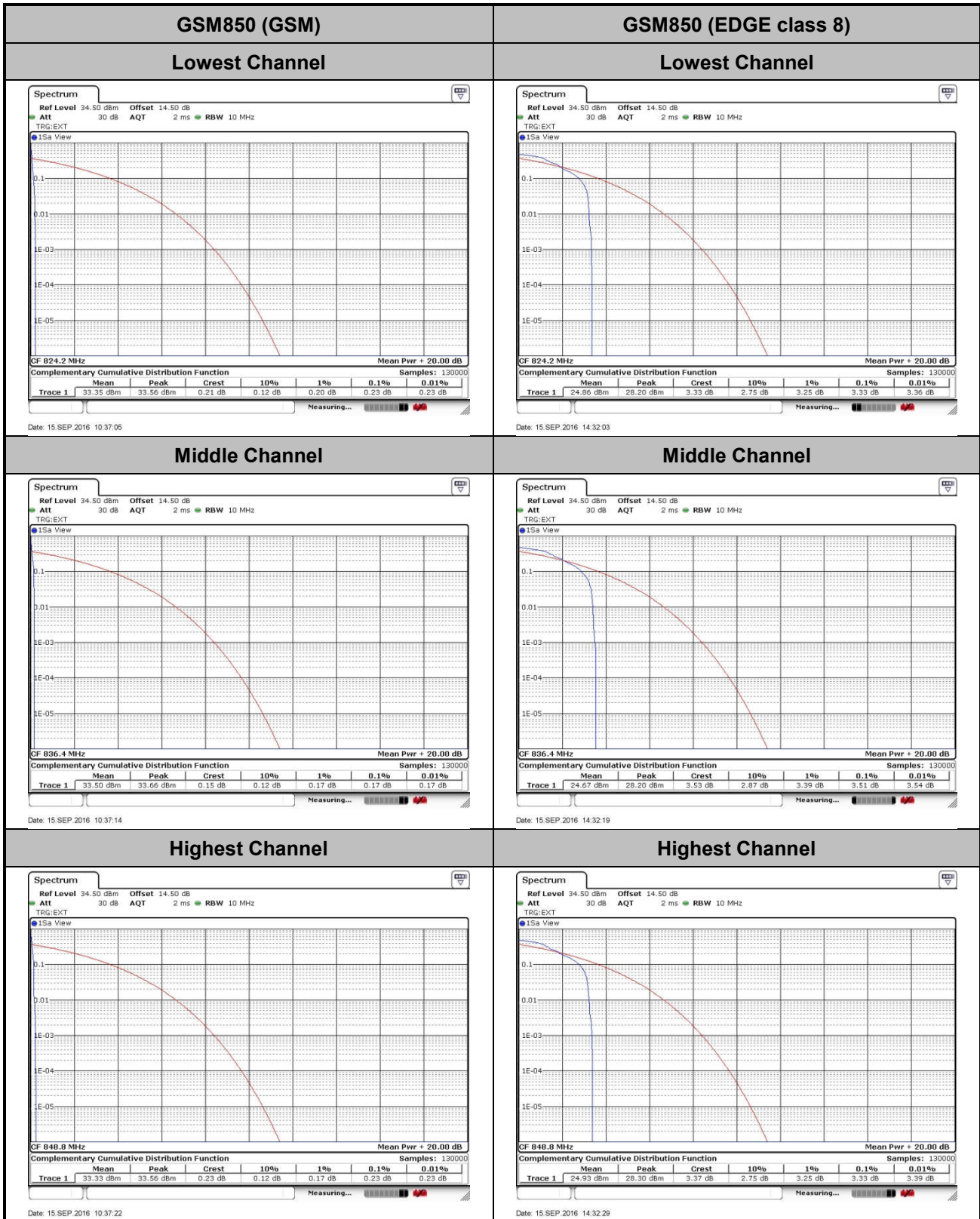



GSM1900 (GSM)

Lowest Channel

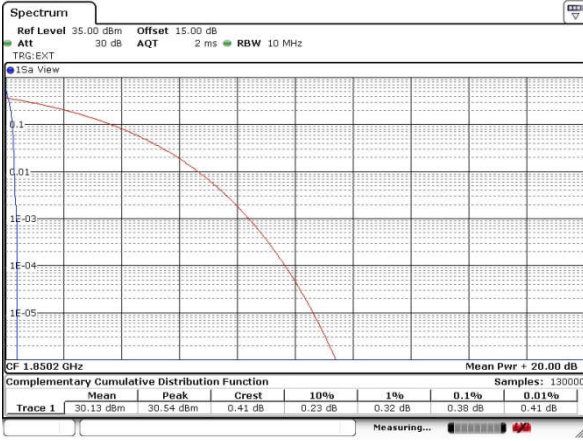

Date: 15 SEP 2016 16:07:10

GSM1900 (EDGE class 8)

Lowest Channel

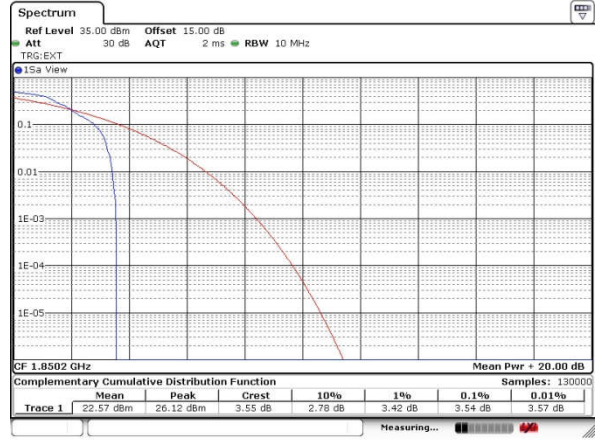

Date: 15 SEP 2016 14:30:10

Middle Channel

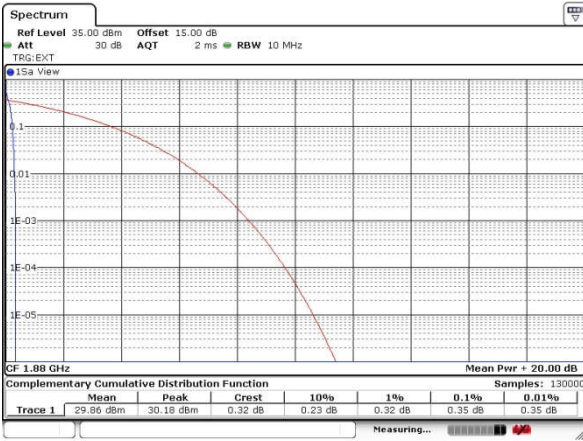

Date: 15 SEP 2016 16:07:20

Middle Channel

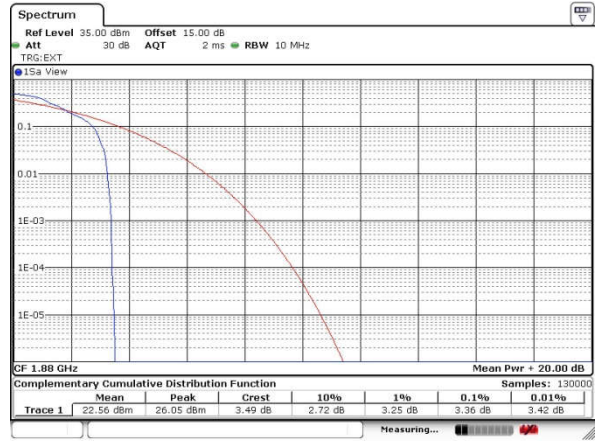

Date: 15 SEP 2016 14:30:32

Highest Channel

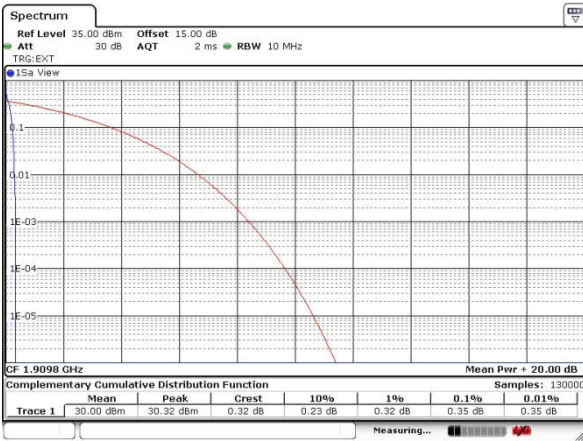

Date: 15 SEP 2016 16:07:26

Highest Channel

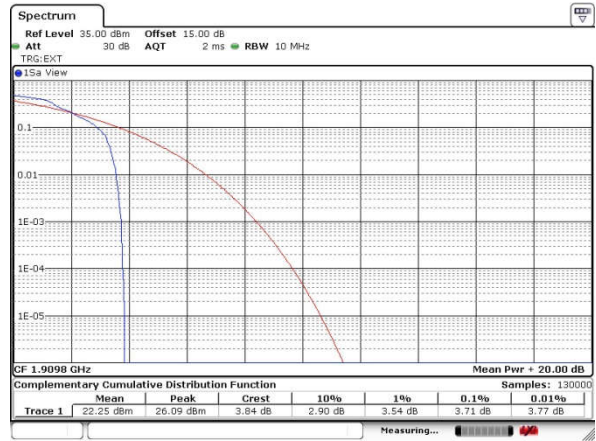

Date: 15 SEP 2016 14:30:43



WCDMA Band V (RMC 12.2Kbps)

Lowest Channel

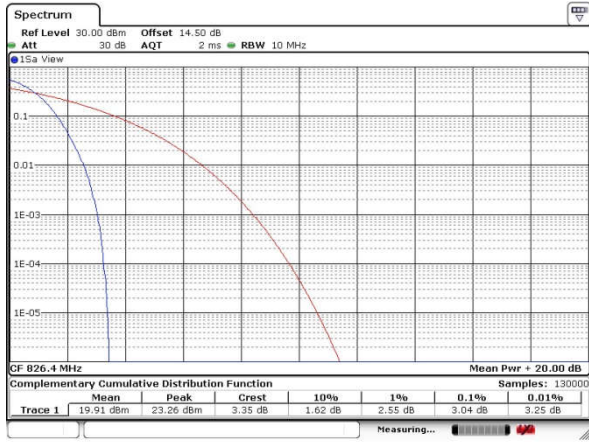

Date: 15 SEP 2016 13:07:48

WCDMA Band II (RMC 12.2Kbps)

Lowest Channel

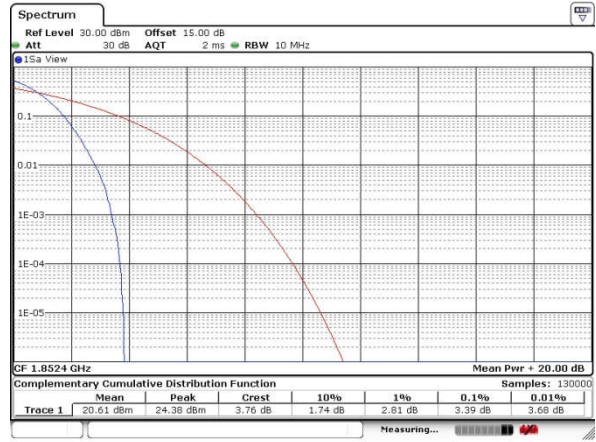

Date: 15 SEP 2016 13:27:10

Middle Channel

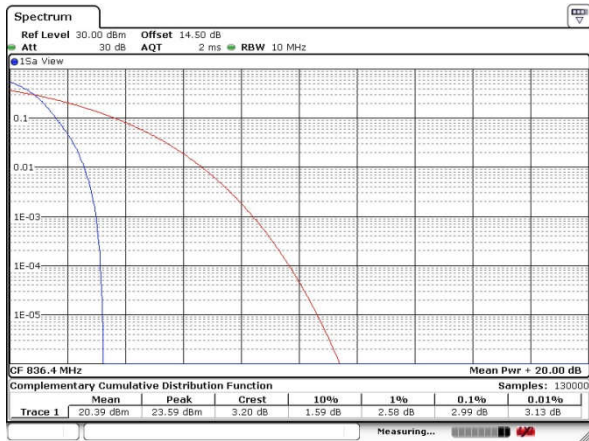

Date: 15 SEP 2016 13:07:54

Middle Channel

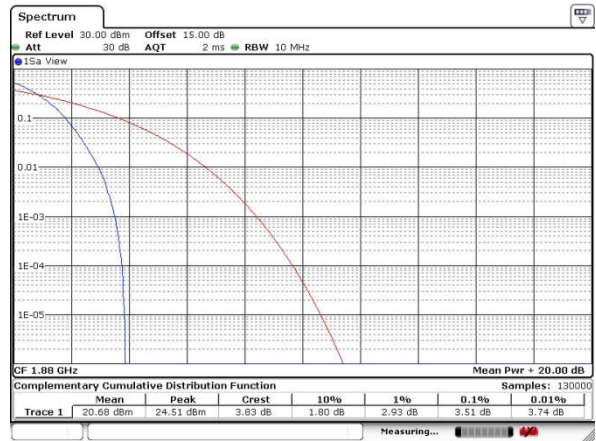

Date: 15 SEP 2016 13:27:18

Highest Channel

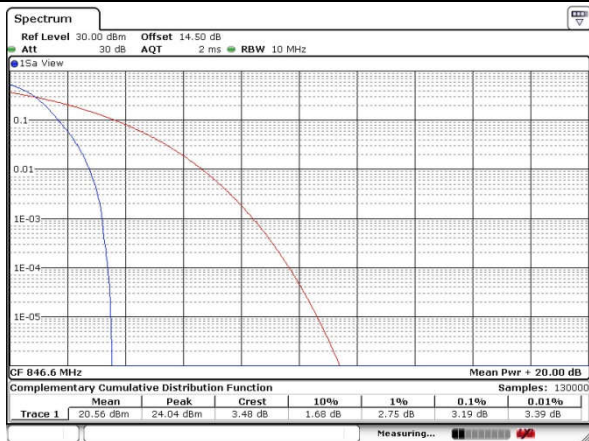

Date: 15 SEP 2016 13:08:00

Highest Channel



Date: 15 SEP 2016 13:27:25



26dB Bandwidth

Mode	GSM850(MHz)	
Mod.	GSM	EDGE class 8
Lowest CH	0.301	0.315
Middle CH	0.302	0.314
Highest CH	0.302	0.314

Mode	GSM1900(MHz)	
Mod.	GSM	EDGE class 8
Lowest CH	0.308	0.314
Middle CH	0.303	0.310
Highest CH	0.303	0.309

Mode	WCDMA Band V(MHz)	WCDMA Band II(MHz)
Mod.	RMC 12.2Kbps	RMC 12.2Kbps
Lowest CH	4.70	4.70
Middle CH	4.73	4.70
Highest CH	4.71	4.69



GSM850 (GSM)

Lowest Channel

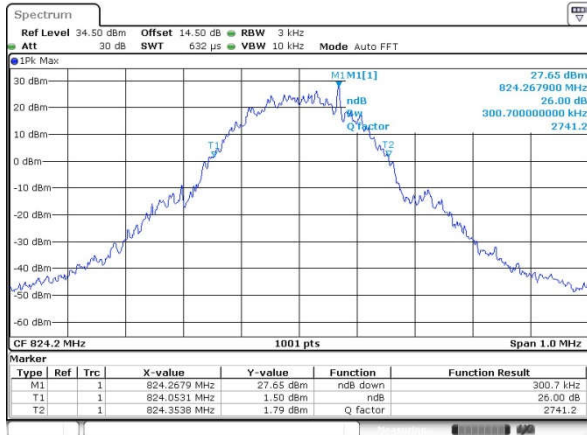

Date: 15 SEP 2016 10:16:43

GSM850 (EDGE class 8)

Lowest Channel

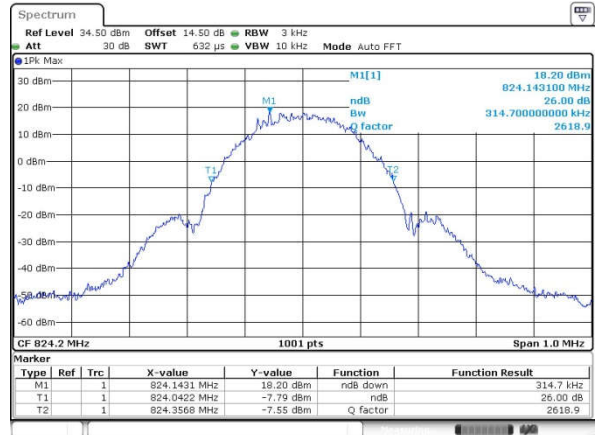

Date: 15 SEP 2016 10:41:02

Middle Channel

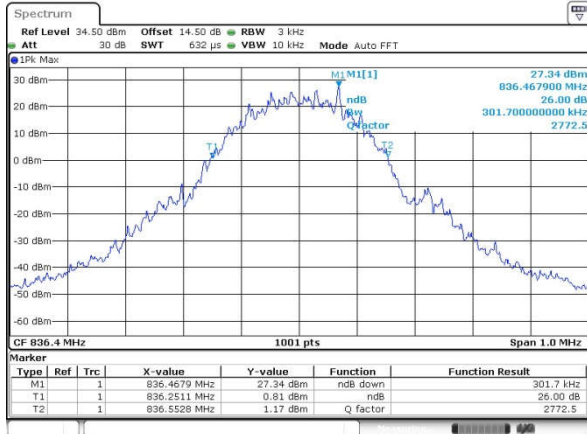

Date: 15 SEP 2016 10:17:12

Middle Channel

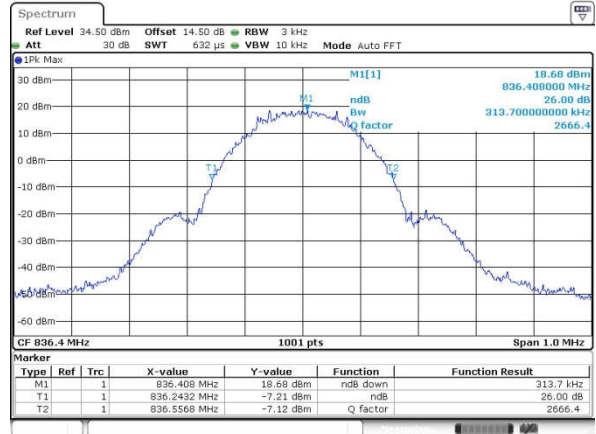

Date: 15 SEP 2016 10:41:38

Highest Channel

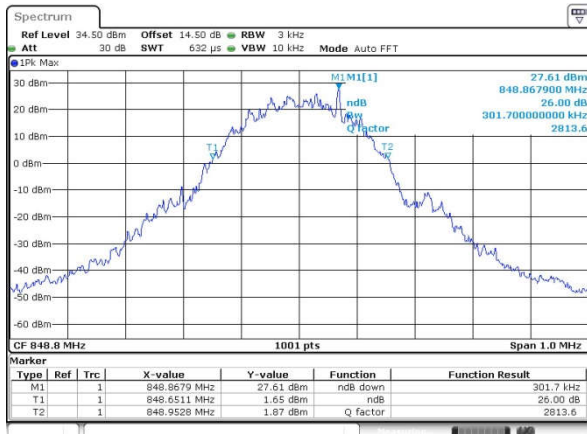

Date: 15 SEP 2016 10:17:40

Highest Channel

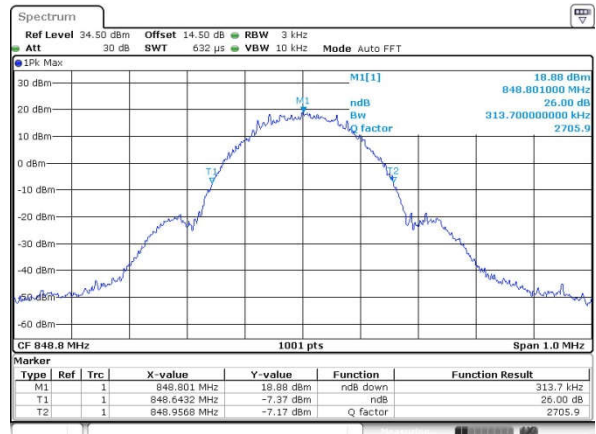

Date: 15 SEP 2016 10:42:22



GSM1900 (GSM)

Lowest Channel

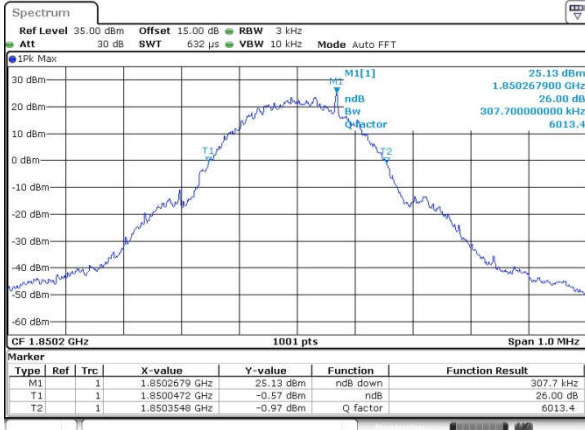

Date: 15 SEP 2016 11:17:14

GSM1900 (EDGE class 8)

Lowest Channel

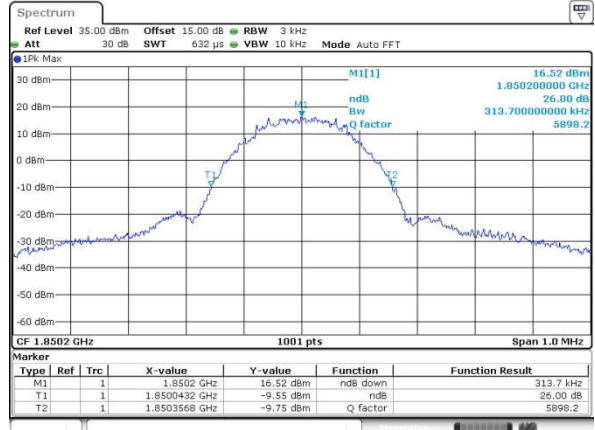

Date: 15 SEP 2016 14:24:06

Middle Channel

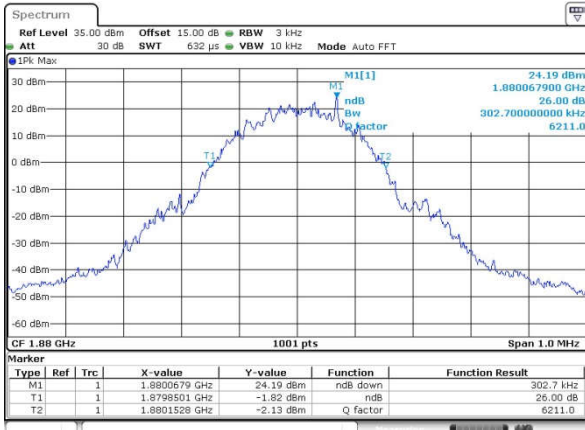

Date: 15 SEP 2016 11:17:42

Middle Channel

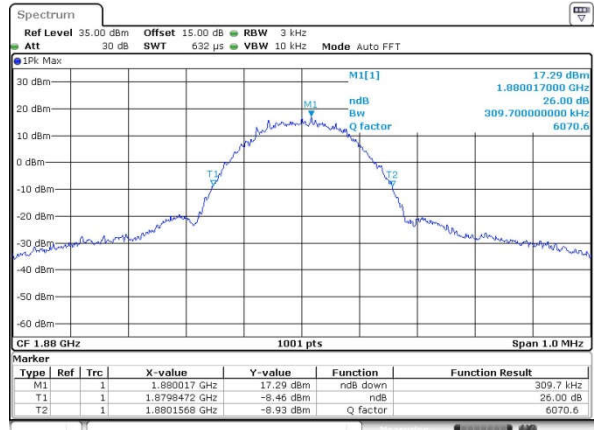

Date: 15 SEP 2016 14:24:40

Highest Channel

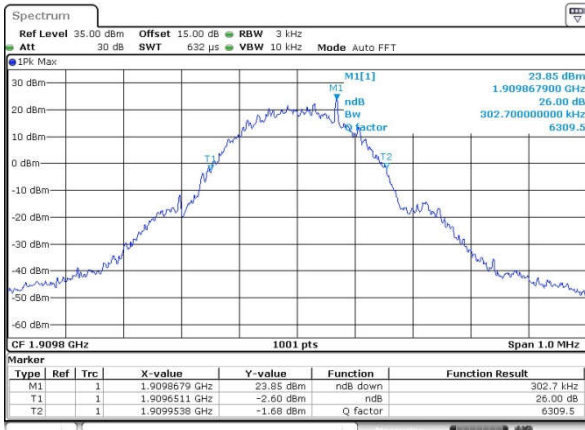

Date: 15 SEP 2016 11:18:11

Highest Channel

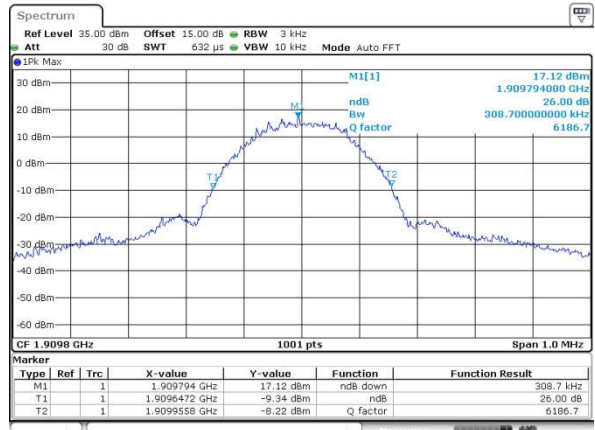

Date: 15 SEP 2016 14:29:32



WCDMA Band V (RMC 12.2Kbps)

Lowest Channel

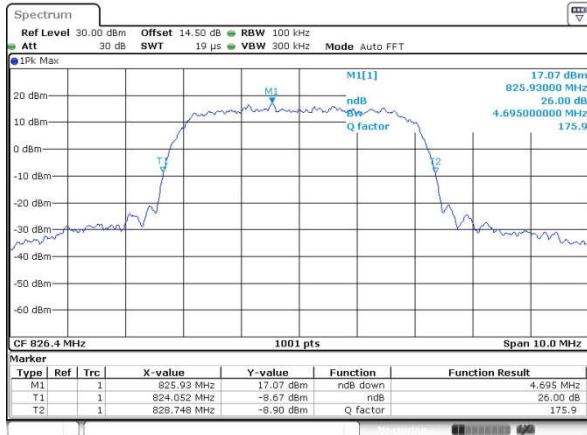

Date: 15 SEP 2016 12:42:51

WCDMA Band II (RMC 12.2Kbps)

Lowest Channel

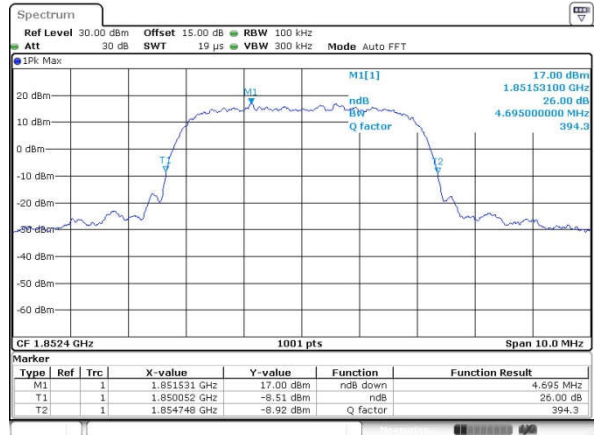

Date: 15 SEP 2016 13:10:47

Middle Channel

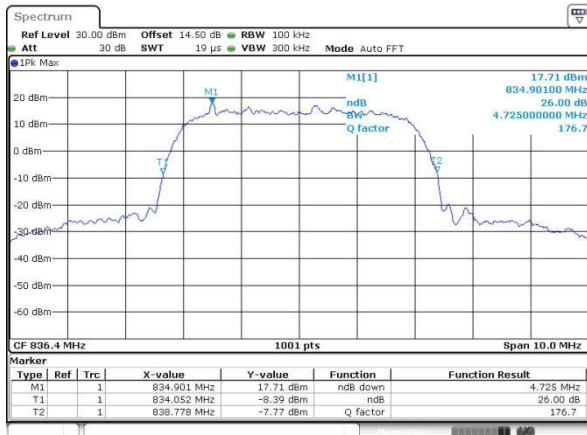

Date: 15 SEP 2016 12:43:20

Middle Channel

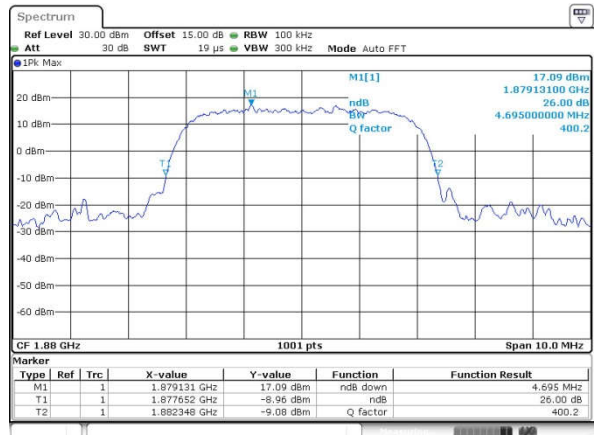

Date: 15 SEP 2016 13:11:16

Highest Channel

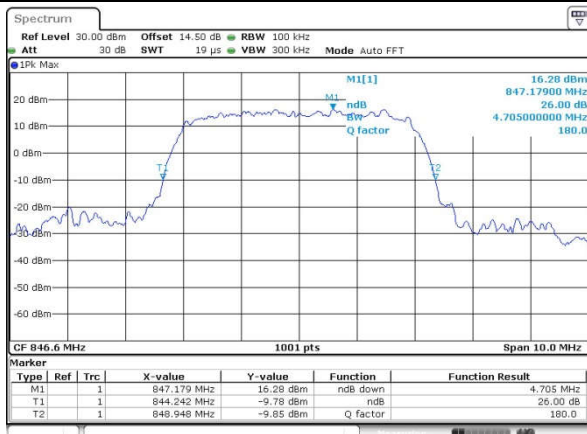

Date: 15 SEP 2016 12:43:48

Highest Channel

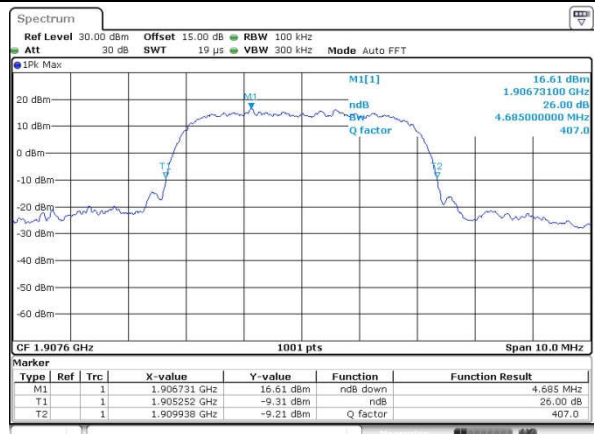

Date: 15 SEP 2016 13:11:44



Occupied Bandwidth

Mode	GSM850(MHz)	
Mod.	GSM	EDGE class 8
Lowest CH	0.243	0.241
Middle CH	0.240	0.243
Highest CH	0.241	0.243

Mode	GSM1900(MHz)	
Mod.	GSM	EDGE class 8
Lowest CH	0.243	0.248
Middle CH	0.244	0.242
Highest CH	0.242	0.244

Mode	WCDMA Band V(MHz)	WCDMA Band II(MHz)
Mod.	RMC 12.2Kbps	RMC 12.2Kbps
Lowest CH	4.13	4.12
Middle CH	4.12	4.12
Highest CH	4.12	4.12



GSM850 (GSM)

Lowest Channel

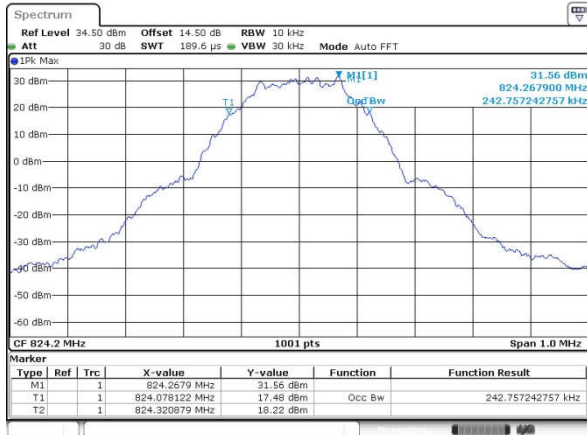

Date: 15 SEP 2016 10:25:48

GSM850 (EDGE class 8)

Lowest Channel

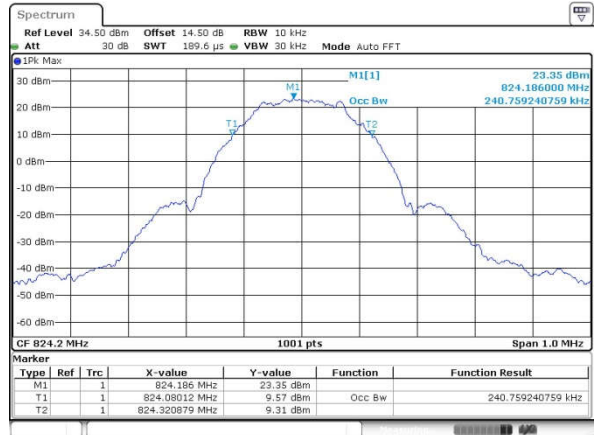

Date: 15 SEP 2016 10:49:05

Middle Channel

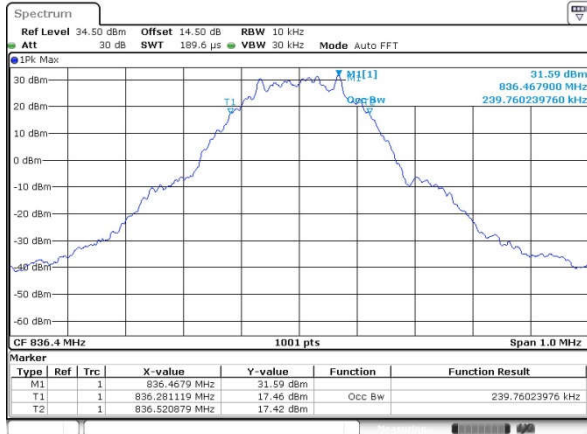

Date: 15 SEP 2016 10:28:16

Middle Channel

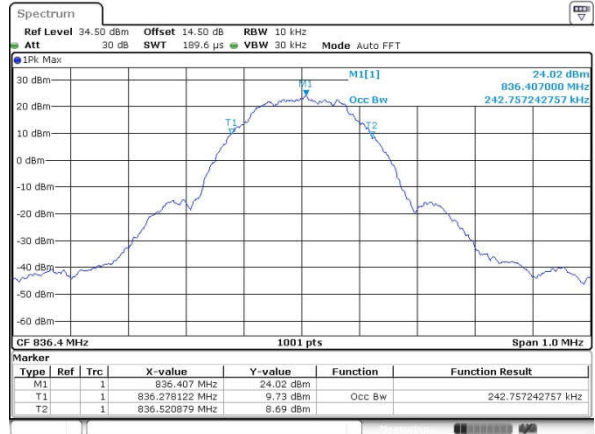

Date: 15 SEP 2016 10:49:43

Highest Channel

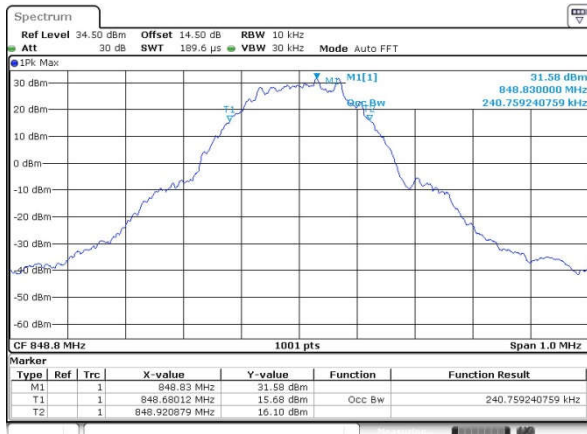

Date: 15 SEP 2016 10:26:44

Highest Channel

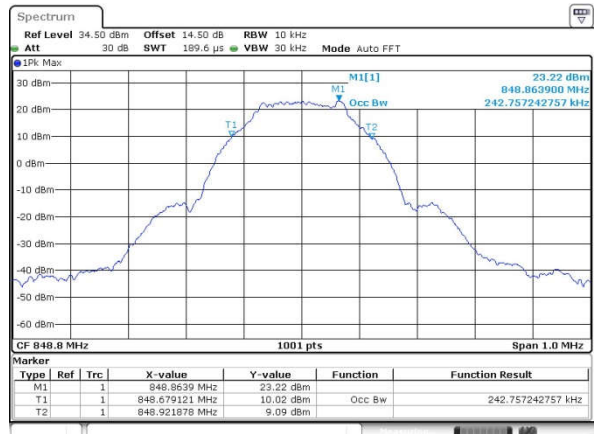

Date: 15 SEP 2016 10:50:31



GSM1900 (GSM)

Lowest Channel

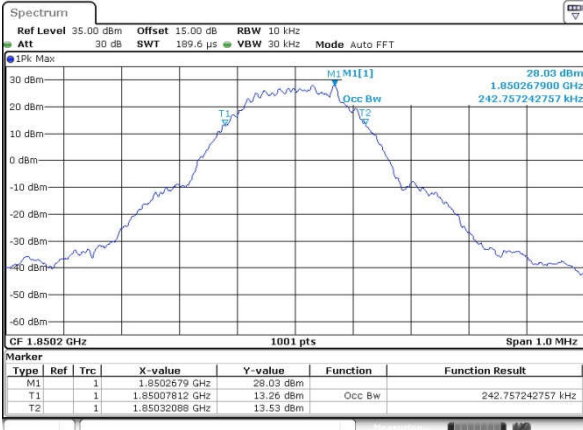

Date: 15 SEP 2016 11:23:31

GSM1900 (EDGE class 8)

Lowest Channel

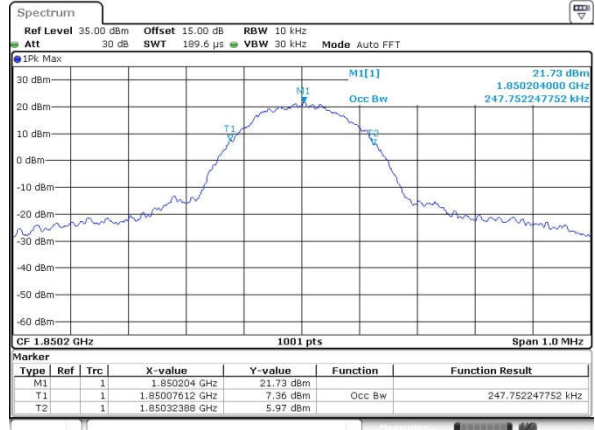

Date: 15 SEP 2016 14:42:13

Middle Channel

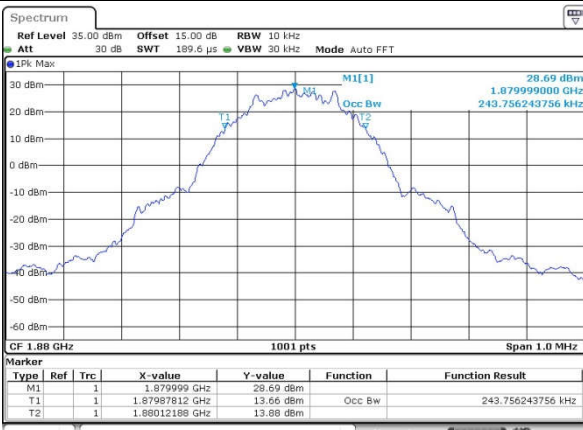

Date: 15 SEP 2016 11:24:00

Middle Channel

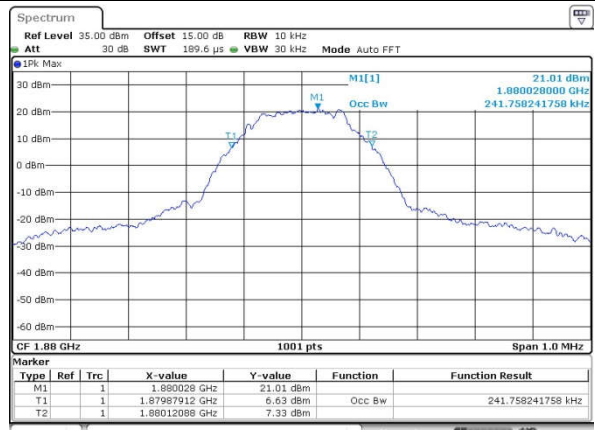

Date: 15 SEP 2016 14:43:26

Highest Channel

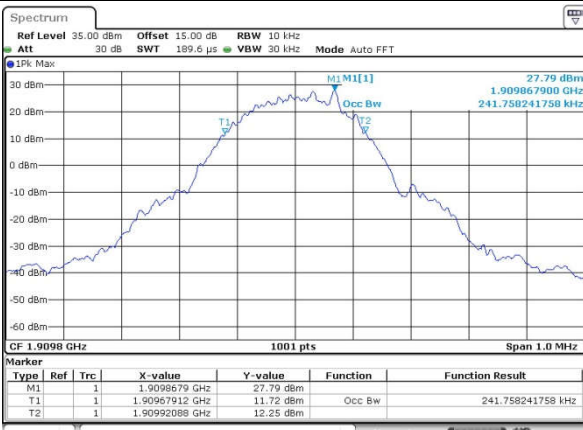

Date: 15 SEP 2016 11:24:28

Highest Channel

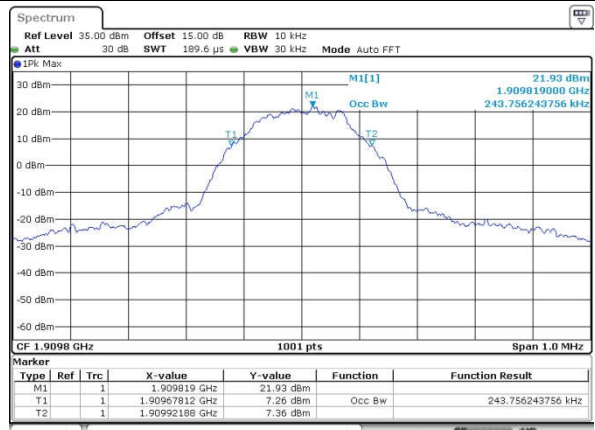

Date: 15 SEP 2016 14:44:02



WCDMA Band V (RMC 12.2Kbps)

Lowest Channel

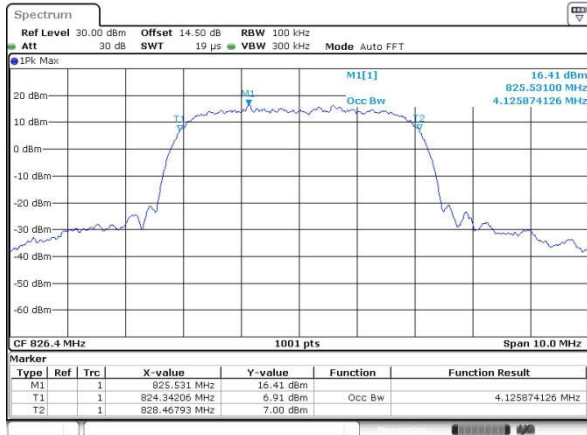

Date: 15 SEP 2016 16:01:22

WCDMA Band II (RMC 12.2Kbps)

Lowest Channel

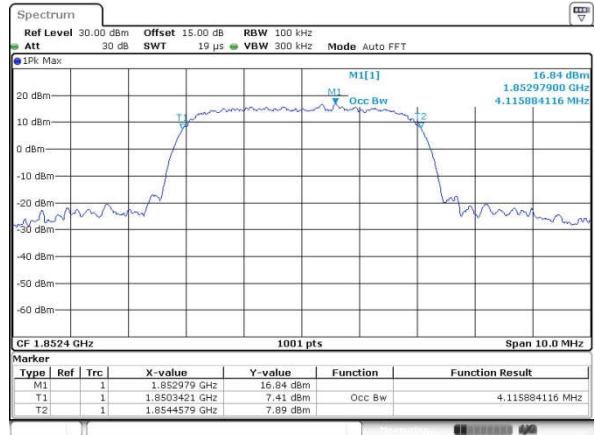

Date: 15 SEP 2016 13:15:15

Middle Channel

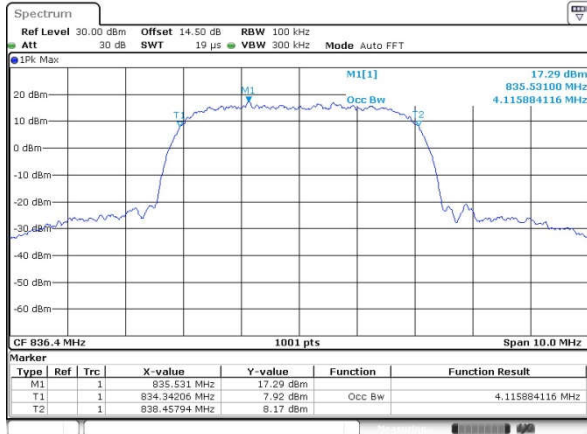

Date: 15 SEP 2016 16:02:55

Middle Channel

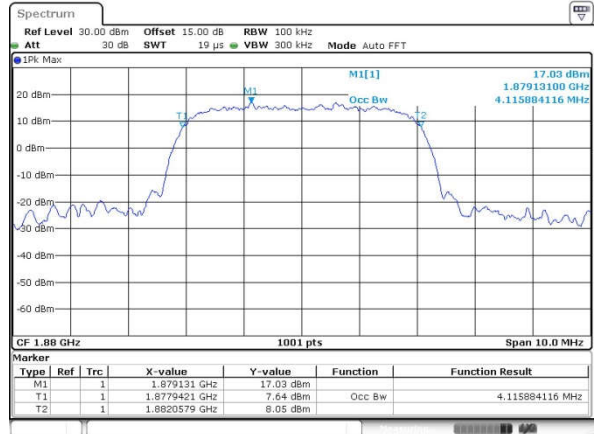

Date: 15 SEP 2016 13:15:43

Highest Channel

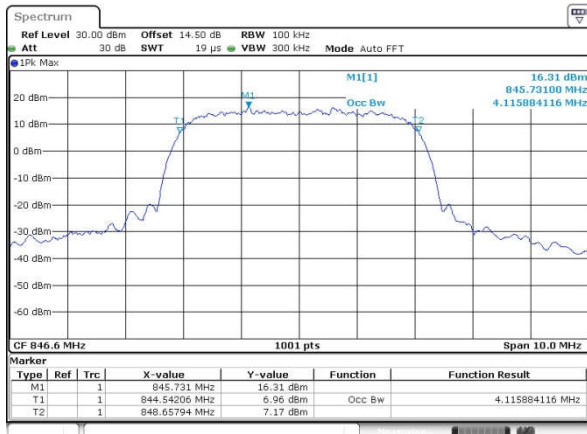

Date: 15 SEP 2016 16:04:43

Highest Channel

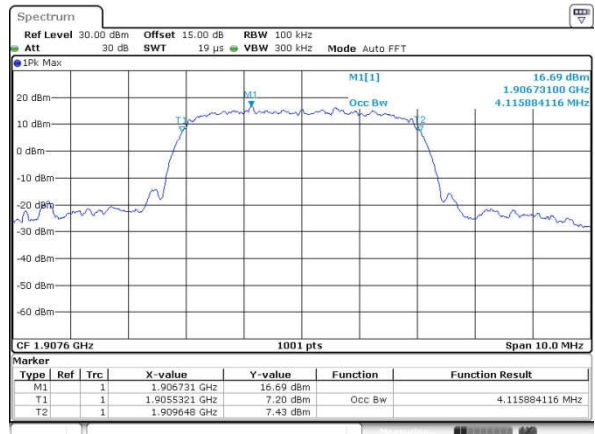

Date: 15 SEP 2016 13:16:12



Conducted Band Edge

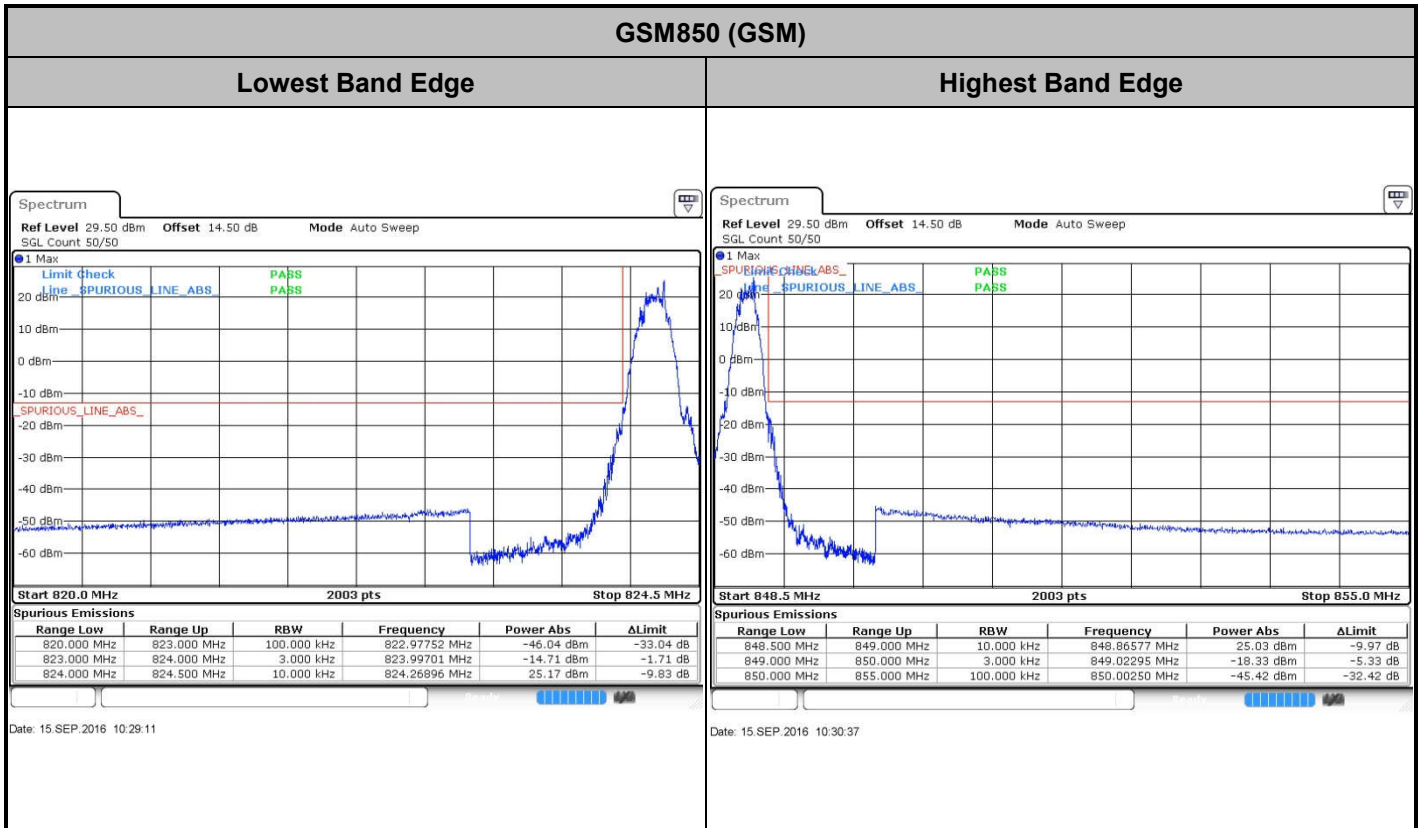

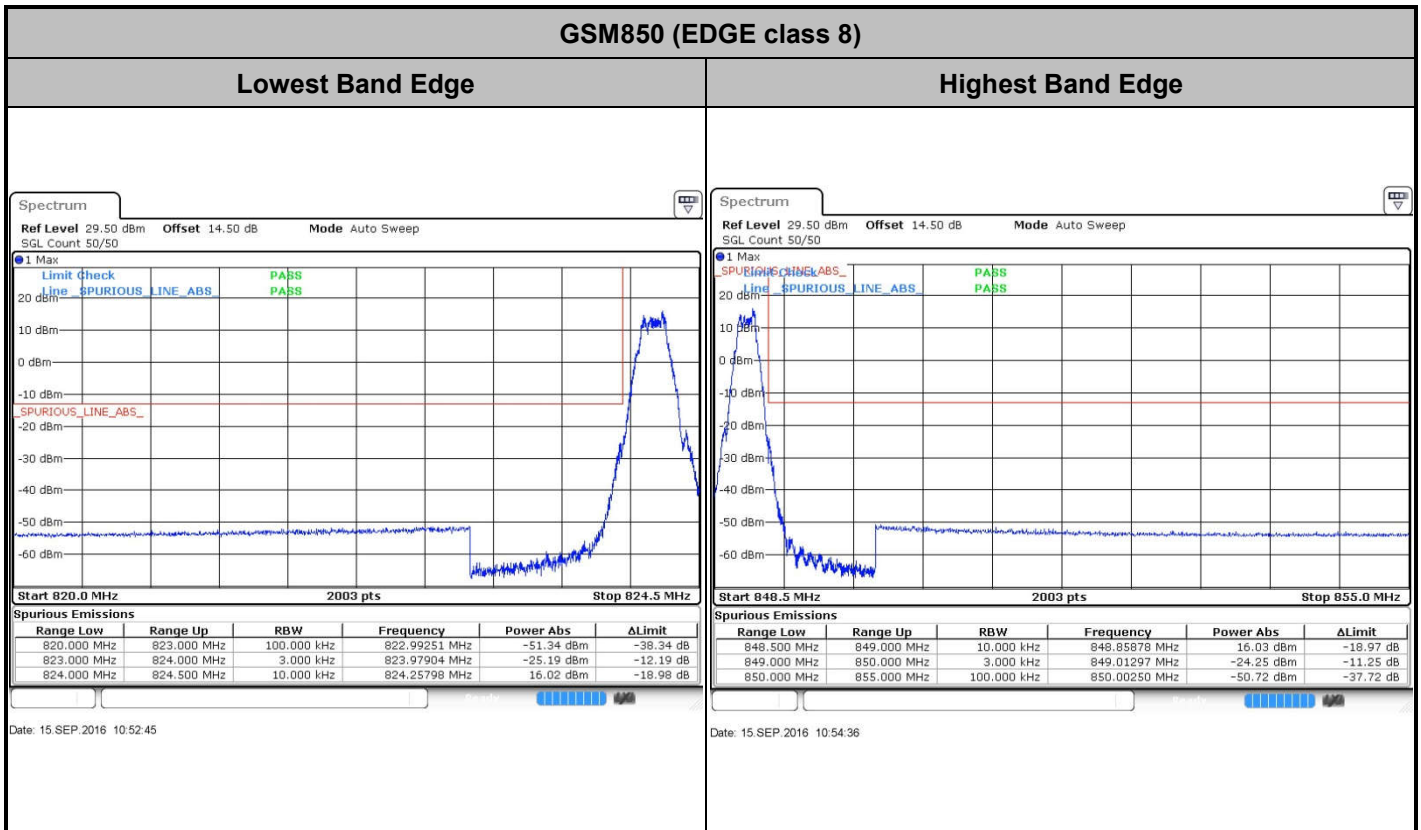



GSM1900 (GSM)

Lowest Band Edge

Highest Band Edge

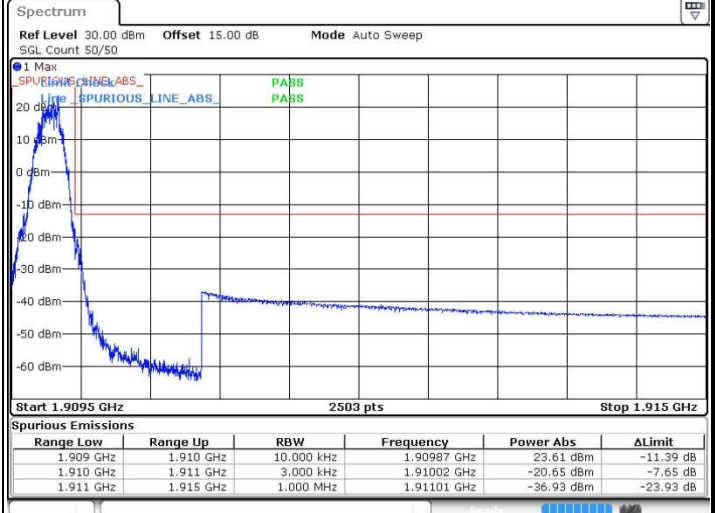
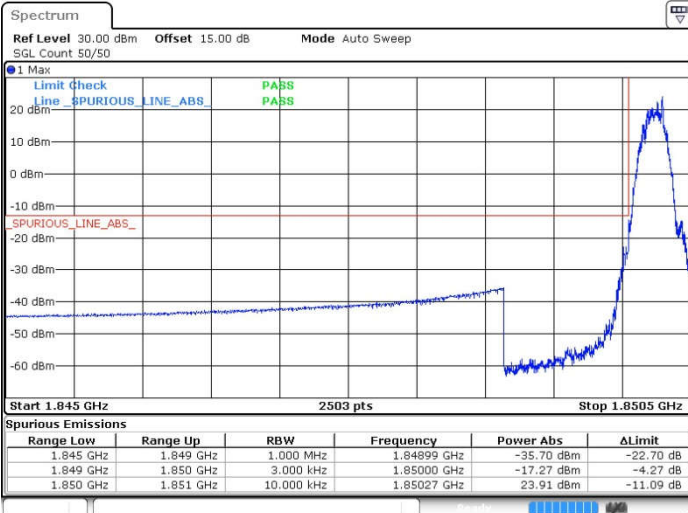

Date: 15.SEP.2016 11:26:00

Date: 15.SEP.2016 11:27:26

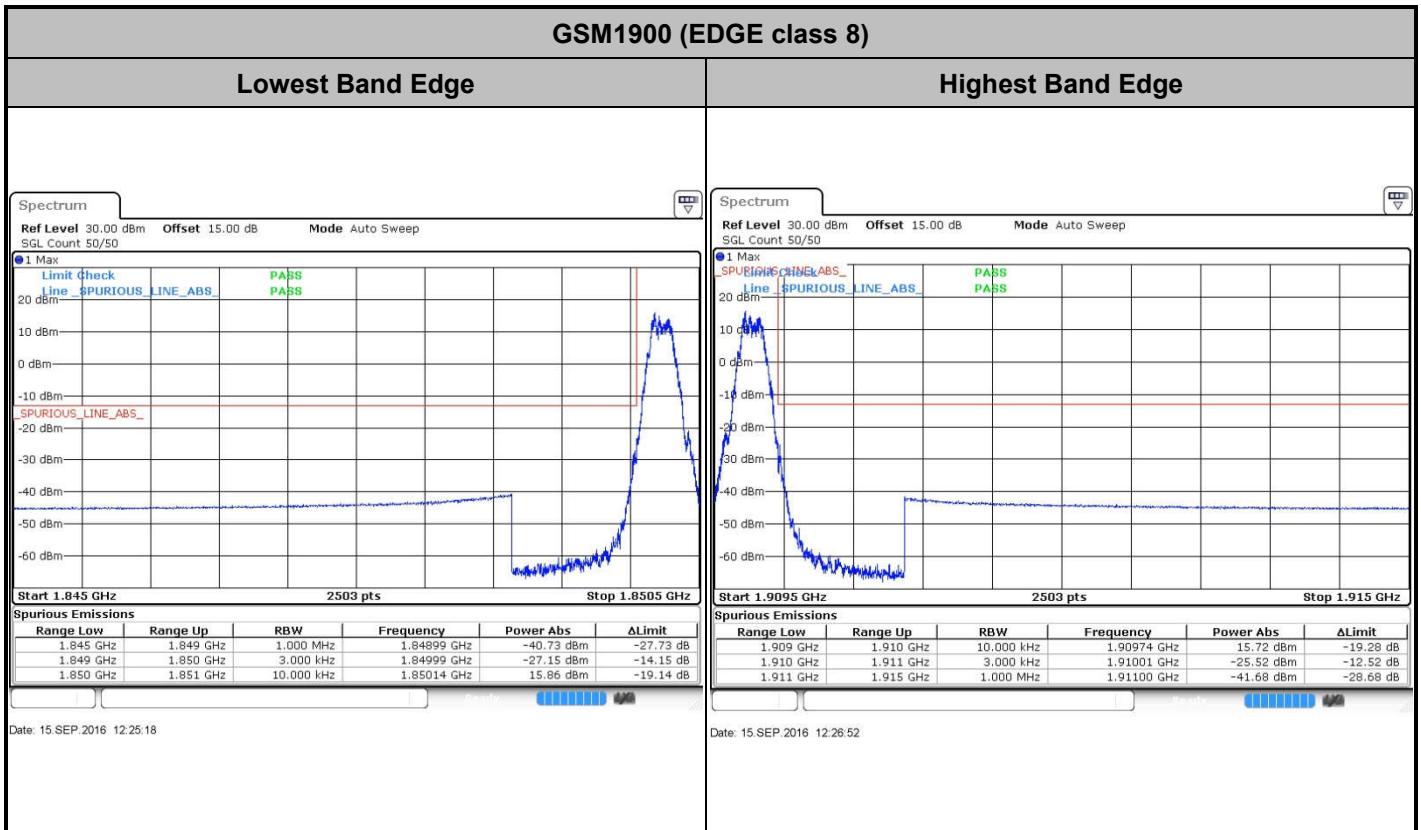



WCDMA Band V (RMC 12.2Kbps)

Lowest Band Edge

Highest Band Edge

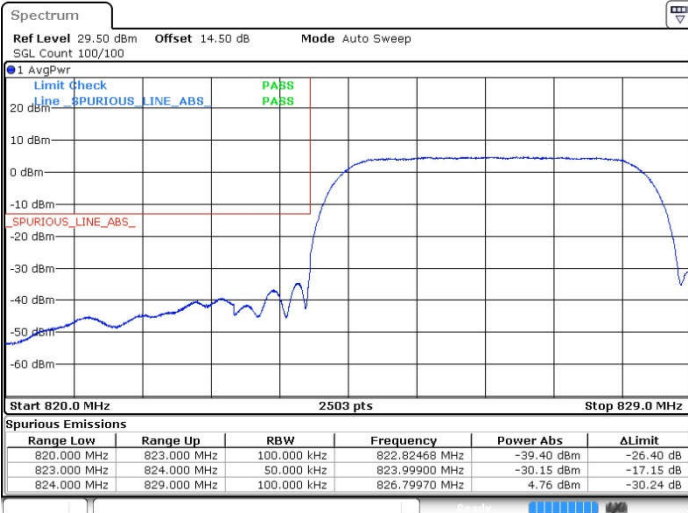

Date: 15.SEP.2016 12:46:38

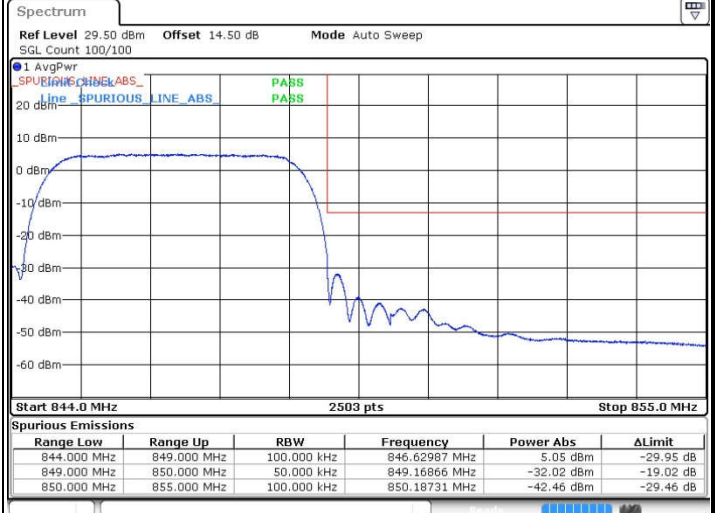

Date: 15.SEP.2016 12:49:19



WCDMA Band II (RMC 12.2Kbps)

Lowest Band Edge

Highest Band Edge

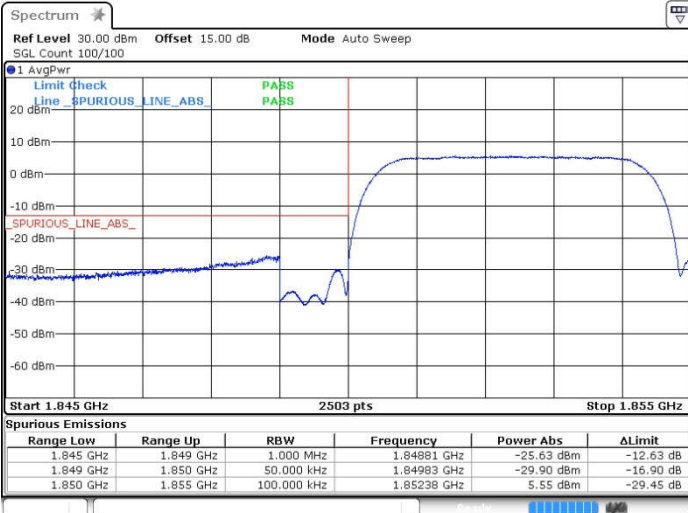

Date: 15.SEP.2016 13:19:17

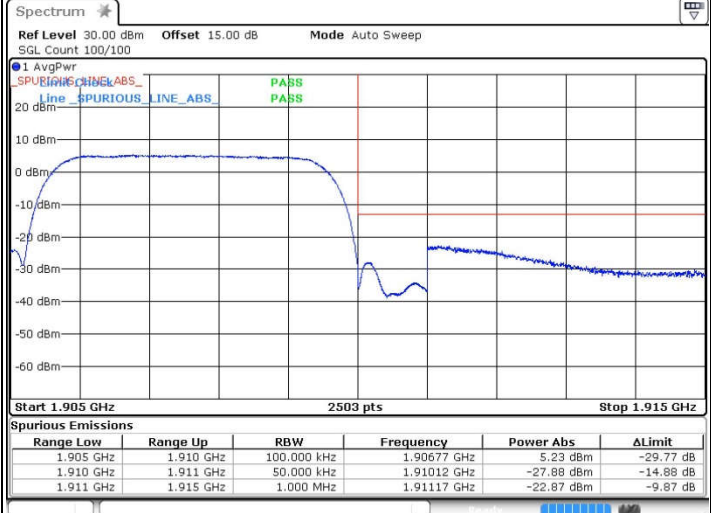

Date: 15.SEP.2016 13:21:58



Conducted Spurious Emission

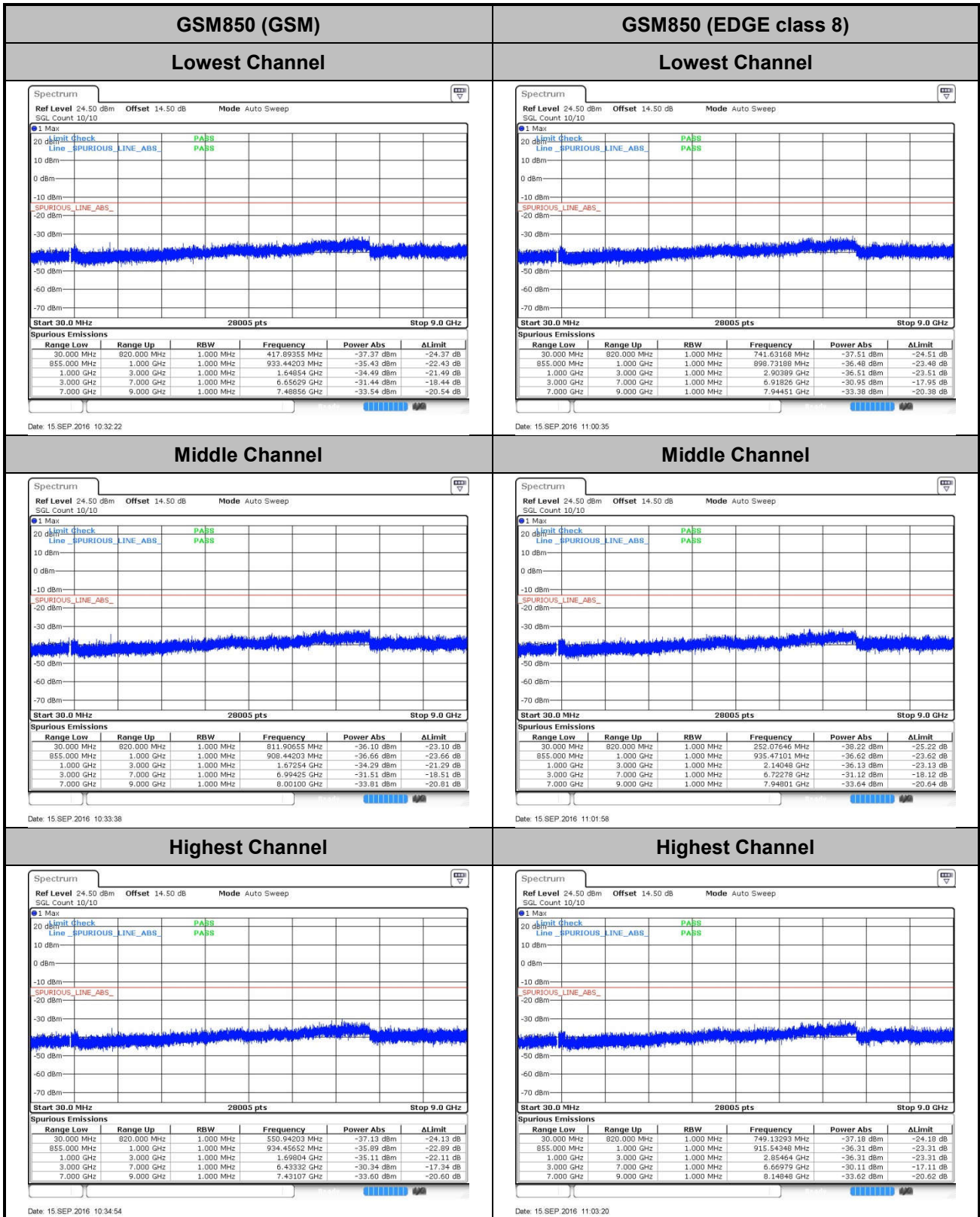



GSM1900 (GSM)

Lowest Channel

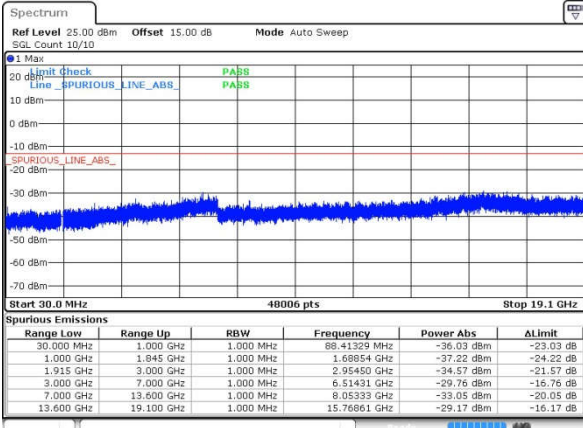

Date: 15 SEP 2016 15:36:15

GSM1900 (EDGE class 8)

Lowest Channel

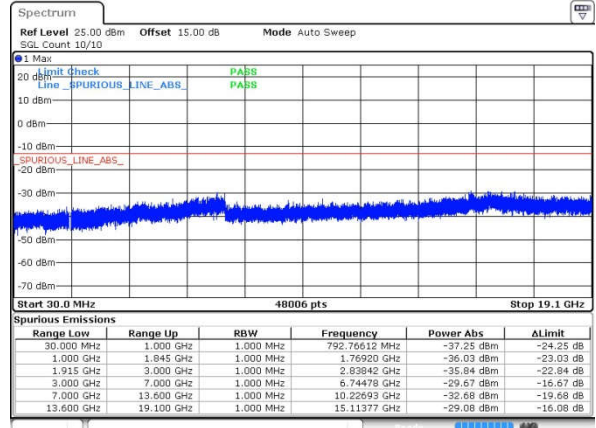

Date: 15 SEP 2016 12:29:15

Middle Channel

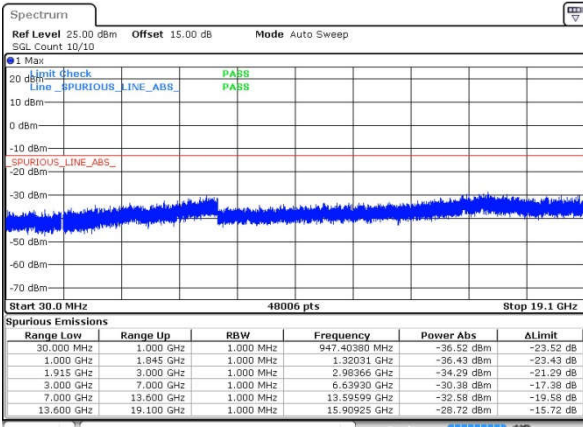

Date: 15 SEP 2016 15:37:34

Middle Channel

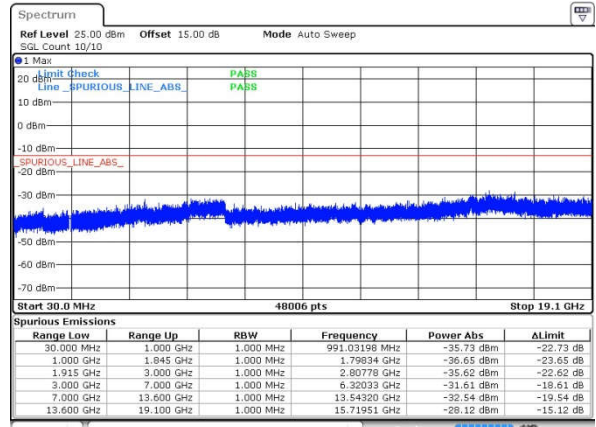

Date: 15 SEP 2016 12:30:48

Highest Channel

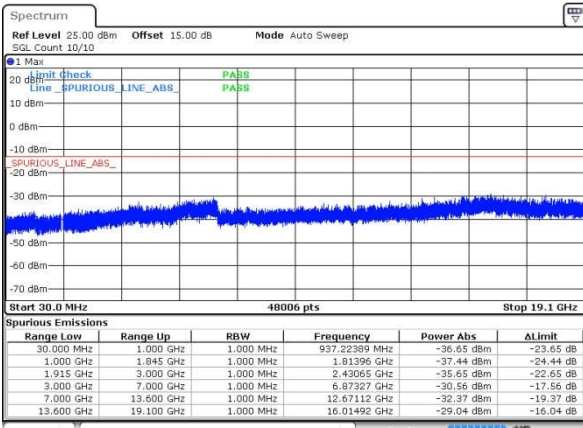

Date: 15 SEP 2016 15:39:01

Highest Channel

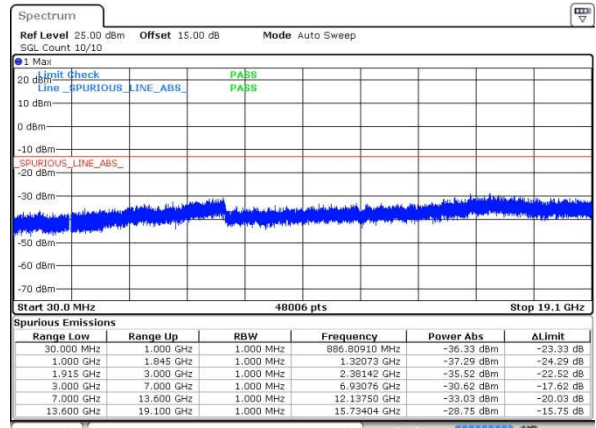

Date: 15 SEP 2016 12:32:11



WCDMA Band V (RMC 12.2Kbps)

Lowest Channel

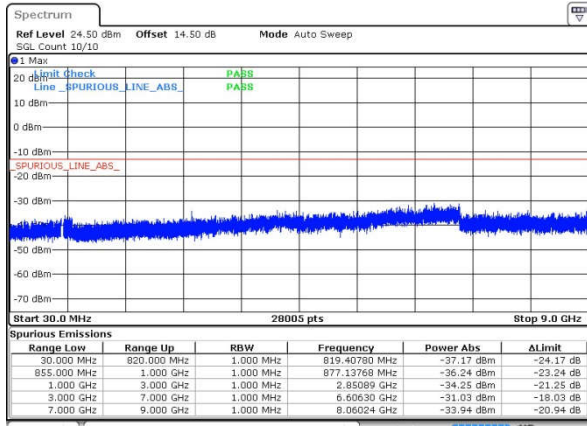

Date: 15 SEP 2016 12:50:38

WCDMA Band II (RMC 12.2Kbps)

Lowest Channel

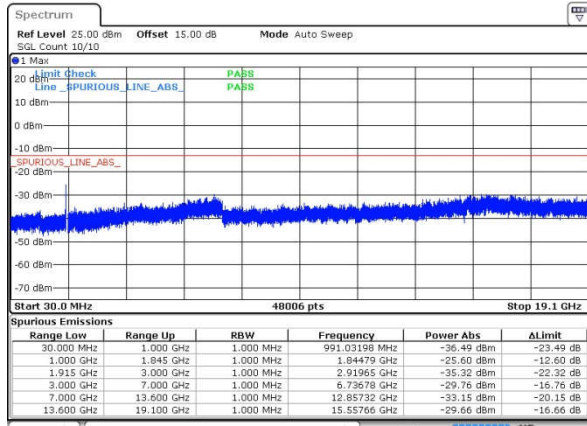

Date: 15 SEP 2016 13:23:51

Middle Channel

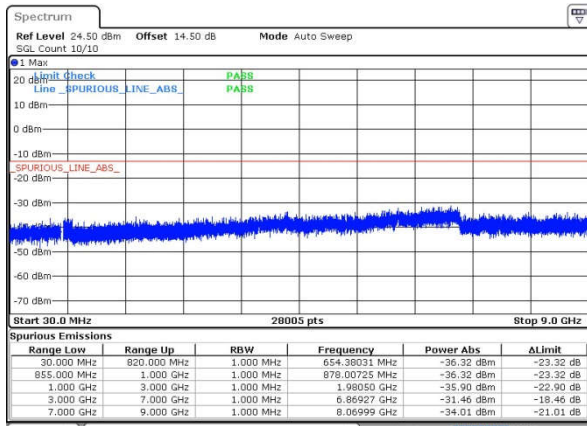

Date: 15 SEP 2016 12:51:54

Middle Channel

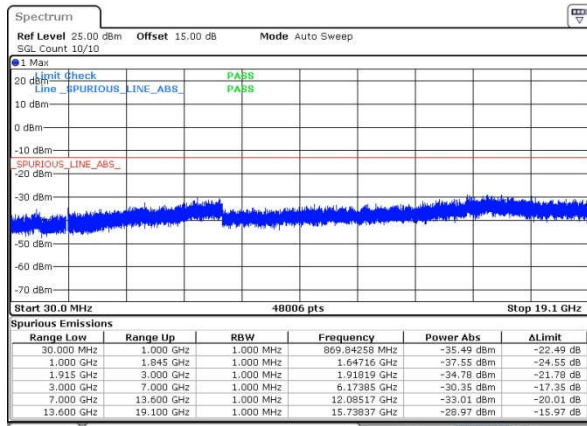

Date: 15 SEP 2016 13:25:07

Highest Channel

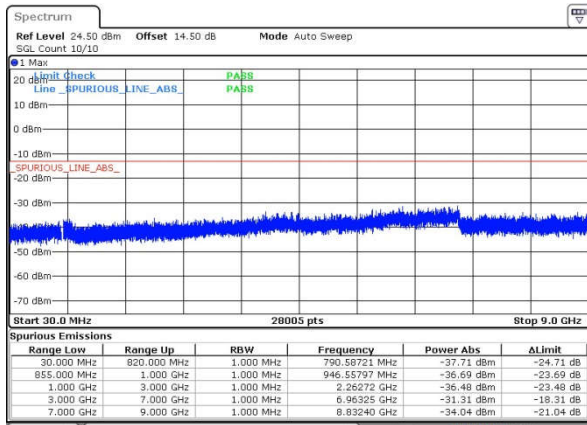

Date: 15 SEP 2016 12:53:06

Highest Channel

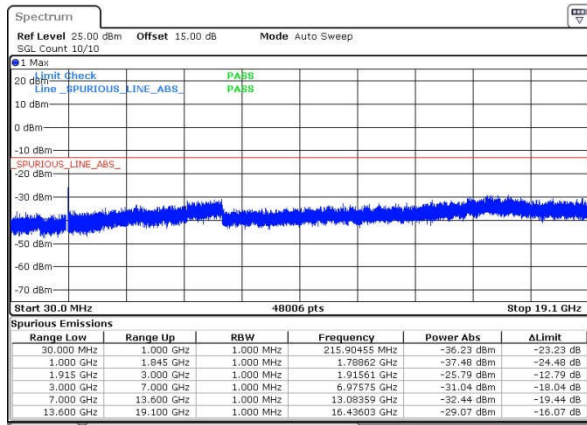

Date: 15 SEP 2016 13:26:23



Frequency Stability

Test Conditions	Middle Channel	GSM850 (GSM)	GSM850 (EDGE class 8)	Limit 2.5ppm
Temperature (°C)	Voltage (Volt)	Deviation (ppm)		Result
50	Normal Voltage	0.0024	0.0036	PASS
40	Normal Voltage	0.0048	0.0012	
30	Normal Voltage	0.0060	0.0060	
20(Ref.)	Normal Voltage	0.0000	0.0000	
10	Normal Voltage	0.0072	0.0012	
0	Normal Voltage	0.0108	0.0024	
-10	Normal Voltage	0.0024	0.0048	
-20	Normal Voltage	0.0132	0.0036	
-30	Normal Voltage	0.0012	0.0072	
20	Maximum Voltage	0.0060	0.0024	
20	Normal Voltage	0.0084	0.0096	
20	Battery End Point	0.0155	0.0060	

Note: Normal Voltage = 3.85V. ; Battery End Point (BEP) = 3.5 V. ; Maximum Voltage =4.35 V

Test Conditions	Middle Channel	GSM1900 (GSM)	GSM1900 (EDGE class 8)	Limit Note 2.
Temperature (°C)	Voltage (Volt)	Deviation (ppm)		Result
50	Normal Voltage	0.0128	0.0138	PASS
40	Normal Voltage	0.0053	0.0149	
30	Normal Voltage	0.0037	0.0011	
20(Ref.)	Normal Voltage	0.0000	0.0000	
10	Normal Voltage	0.0011	0.0016	
0	Normal Voltage	0.0016	0.0128	
-10	Normal Voltage	0.0027	0.0144	
-20	Normal Voltage	0.0005	0.0160	
-30	Normal Voltage	0.0138	0.0027	
20	Maximum Voltage	0.0160	0.0011	
20	Normal Voltage	0.0016	0.0117	
20	Battery End Point	0.0011	0.0005	

Note:

1. Normal Voltage = 3.85V. ; Battery End Point (BEP) = 3.5 V. ; Maximum Voltage =4.35 V
2. The frequency fundamental emissions stay within the authorized frequency block based on the frequency deviation measured is small.



Test Conditions	Middle Channel	WCDMA Band V (RMC 12.2Kbps)	Limit 2.5ppm
Temperature (°C)	Voltage (Volt)	Deviation (ppm)	Result
50	Normal Voltage	0.0024	PASS
40	Normal Voltage	0.0036	
30	Normal Voltage	0.0096	
20(Ref.)	Normal Voltage	0.0000	
10	Normal Voltage	0.0036	
0	Normal Voltage	0.0024	
-10	Normal Voltage	0.0167	
-20	Normal Voltage	0.0060	
-30	Normal Voltage	0.0024	
20	Maximum Voltage	0.0012	
20	Normal Voltage	0.0012	
20	Battery End Point	0.0143	

Note: Normal Voltage = 3.85V. ; Battery End Point (BEP) = 3.5 V. ; Maximum Voltage =4.35 V

Test Conditions	Middle Channel	WCDMA Band II (RMC 12.2Kbps)	Limit Note 2.
Temperature (°C)	Voltage (Volt)	Deviation (ppm)	Result
50	Normal Voltage	0.0011	PASS
40	Normal Voltage	0.0021	
30	Normal Voltage	0.0016	
20(Ref.)	Normal Voltage	0.0000	
10	Normal Voltage	0.0005	
0	Normal Voltage	0.0032	
-10	Normal Voltage	0.0005	
-20	Normal Voltage	0.0074	
-30	Normal Voltage	0.0016	
20	Maximum Voltage	0.0032	
20	Normal Voltage	0.0005	
20	Battery End Point	0.0037	

Note:

1. Normal Voltage = 3.85V. ; Battery End Point (BEP) = 3.5 V. ; Maximum Voltage =4.35 V
2. The frequency fundamental emissions stay within the authorized frequency block based on the frequency deviation measured is small.



Appendix B. Test Results of Radiated Test

ERP/EIRP

Channel	Mode	Horizontal		Vertical	
		ERP(dBm)	ERP(W)	ERP(dBm)	ERP(W)
Lowest	GSM850 GSM	26.06	0.4036	17.21	0.0526
Middle		26.54	0.4508	17.32	0.0540
Highest		26.70	0.4677	17.51	0.0564
Lowest	GSM850 EDGE class 8	18.91	0.0778	10.07	0.0102
Middle		19.69	0.0931	10.47	0.0111
Highest		19.64	0.0920	10.54	0.0113
Lowest	WCDMA Band V RMC 12.2Kbps	18.00	0.0630	8.68	0.0074
Middle		18.50	0.0708	8.77	0.0075
Highest		19.05	0.0804	9.29	0.0085
Limit	ERP < 7W	Result		PASS	

Channel	Mode	Horizontal		Vertical	
		EIRP(dBm)	EIRP(W)	EIRP(dBm)	EIRP(W)
Lowest	GSM1900 GSM	28.87	0.7709	28.89	0.7745
Middle		28.20	0.6607	28.24	0.6668
Highest		28.72	0.7447	28.75	0.7499
Lowest	GSM1900 EDGE class 8	23.88	0.2443	23.92	0.2466
Middle		23.61	0.2296	23.60	0.2291
Highest		22.73	0.1874	22.47	0.1879
Lowest	WCDMA Band II RMC 12.2Kbps	21.74	0.1493	21.68	0.1472
Middle		22.09	0.1618	22.02	0.1592
Highest		22.52	0.1786	22.22	0.1667
Limit	EIRP < 2W	Result		PASS	



Radiated Spurious Emission

GSM850 (GSM)									
Channel	Frequency (MHz)	ERP (dBm)	Limit (dBm)	Over Limit (dB)	SPA Reading (dBm)	S.G. Power (dBm)	TX Cable loss (dB)	TX Antenna Gain (dBi)	Polarization (H/V)
Middle	1672	-44.72	-13	-31.72	-48.82	-46.54	1.23	5.20	H
	2509	-62.59	-13	-49.59	-67.44	-64.82	1.52	5.90	H
	3345	-66.72	-13	-53.72	-74.28	-69.50	1.77	6.70	H
	1672	-49.78	-13	-36.78	-50.80	-51.60	1.23	5.20	V
	2509	-57.82	-13	-44.82	-66.12	-60.05	1.52	5.90	V
	3345	-63.33	-13	-50.33	-74.43	-66.11	1.77	6.70	V

Remark: Spurious emissions within 30-1000MHz were found more than 20dB below limit line.

GSM850 (EDGE class 8)									
Channel	Frequency (MHz)	ERP (dBm)	Limit (dBm)	Over Limit (dB)	SPA Reading (dBm)	S.G. Power (dBm)	TX Cable loss (dB)	TX Antenna Gain (dBi)	Polarization (H/V)
Middle	1672	-47.40	-13	-34.40	-50.65	-49.22	1.23	5.20	H
	2509	-62.87	-13	-49.87	-67.72	-65.10	1.52	5.90	H
	3345	-66.49	-13	-53.49	-74.05	-69.27	1.77	6.70	H
	1672	-49.66	-13	-36.66	-50.73	-51.48	1.23	5.20	V
	2509	-59.60	-13	-46.60	-67.90	-61.83	1.52	5.90	V
	3345	-63.23	-13	-50.23	-74.33	-66.01	1.77	6.70	V

Remark: Spurious emissions within 30-1000MHz were found more than 20dB below limit line.



GSM1900 (GSM)									
Channel	Frequency (MHz)	EIRP (dBm)	Limit (dBm)	Over Limit (dB)	SPA Reading (dBm)	S.G. Power (dBm)	TX Cable loss (dB)	TX Antenna Gain (dBi)	Polarization (H/V)
Middle	3760	-64.25	-13	-51.25	-73.26	-69.11	1.93	6.80	H
	5640	-61.62	-13	-48.62	-69.54	-68.92	2.40	9.70	H
	7520	-60.89	-13	-47.89	-71.26	-69.94	2.76	11.81	H
	3760	-65.10	-13	-52.10	-74.41	-69.97	1.93	6.80	V
	5640	-61.60	-13	-48.60	-69.55	-68.90	2.40	9.70	V
	7520	-59.58	-13	-46.58	-72.07	-68.63	2.76	11.81	V

Remark: Spurious emissions within 30-1000MHz were found more than 20dB below limit line.

GSM1900 (EDGE class 8)									
Channel	Frequency (MHz)	EIRP (dBm)	Limit (dBm)	Over Limit (dB)	SPA Reading (dBm)	S.G. Power (dBm)	TX Cable loss (dB)	TX Antenna Gain (dBi)	Polarization (H/V)
Middle	3760	-64.41	-13	-51.41	-73.42	-69.27	1.93	6.80	H
	5640	-61.80	-13	-48.80	-69.72	-69.10	2.40	9.70	H
	7520	-61.52	-13	-48.52	-71.89	-70.57	2.76	11.81	H
	3760	-65.15	-13	-52.15	-74.46	-70.02	1.93	6.80	V
	5640	-61.90	-13	-48.90	-69.85	-69.20	2.40	9.70	V
	7520	-59.77	-13	-46.77	-72.26	-68.82	2.76	11.81	V

Remark: Spurious emissions within 30-1000MHz were found more than 20dB below limit line.



WCDMA Band V(RMC 12.2Kbps)									
Channel	Frequency (MHz)	ERP (dBm)	Limit (dBm)	Over Limit (dB)	SPA Reading (dBm)	S.G. Power (dBm)	TX Cable loss (dB)	TX Antenna Gain (dBi)	Polarization (H/V)
Middle	1672	-67.59	-13	-54.59	-65.79	-69.41	1.23	5.20	H
	2509	-67.33	-13	-54.33	-72.18	-69.56	1.52	5.90	H
	3345	-67.02	-13	-54.02	-74.58	-69.80	1.77	6.70	H
	1672	-67.41	-13	-54.41	-65.36	-69.23	1.23	5.20	V
	2509	-63.52	-13	-50.52	-71.82	-65.75	1.52	5.90	V
	3345	-63.04	-13	-50.04	-74.14	-65.82	1.77	6.70	V

Remark: Spurious emissions within 30-1000MHz were found more than 20dB below limit line.

WCDMA Band II(RMC 12.2Kbps)									
Channel	Frequency (MHz)	EIRP (dBm)	Limit (dBm)	Over Limit (dB)	SPA Reading (dBm)	S.G. Power (dBm)	TX Cable loss (dB)	TX Antenna Gain (dBi)	Polarization (H/V)
Middle	3760	-64.49	-13	-51.49	-73.50	-69.35	1.93	6.80	H
	5640	-61.25	-13	-48.25	-69.17	-68.55	2.40	9.70	H
	7520	-61.37	-13	-48.37	-71.74	-70.42	2.76	11.81	H
	3760	-64.55	-13	-51.55	-73.86	-69.42	1.93	6.80	V
	5640	-61.84	-13	-48.84	-69.79	-69.14	2.40	9.70	V
	7520	-60.02	-13	-47.02	-72.51	-69.07	2.76	11.81	V

Remark: Spurious emissions within 30-1000MHz were found more than 20dB below limit line.