



FCC RF Test Report

APPLICANT : Lenovo Mobile Communication
Technology Ltd.
EQUIPMENT : Mobile Cellular Phone
BRAND NAME : Lenovo
MODEL NAME : Lenovo K53a48
FCC ID : YCNK53A48
STANDARD : FCC Part 15 Subpart C §15.247
CLASSIFICATION : (DTS) Digital Transmission System

The product was received on Jun. 20, 2016 and testing was completed on Sep. 18, 2016. We, SPORTON INTERNATIONAL (KUNSHAN) INC., would like to declare that the tested sample has been evaluated in accordance with the test procedures and has been in compliance with the applicable technical standards.

The test results in this report apply exclusively to the tested model / sample. Without written approval of SPORTON INTERNATIONAL (KUNSHAN) INC., the test report shall not be reproduced except in full.

Prepared by: James Huang / Manager



Approved by: Jones Tsai / Manager

SPORTON INTERNATIONAL (KUNSHAN) INC.
No. 3-2, PingXiang Road, Kunshan, Jiangsu Province, P. R. China



TABLE OF CONTENTS

1 GENERAL DESCRIPTION 5

1.1 Applicant 5

1.2 Manufacturer 5

1.3 Product Feature of Equipment Under Test 5

1.4 Product Specification of Equipment Under Test 5

1.5 Specification of Accessory 6

1.6 Modification of EUT 7

1.7 Testing Location 7

1.8 Applicable Standards 7

2 TEST CONFIGURATION OF EQUIPMENT UNDER TEST 8

2.1 Carrier Frequency Channel 8

2.2 Pre-Scanned RF Power 9

2.3 Test Mode 10

2.4 Connection Diagram of Test System 11

2.5 Support Unit used in test configuration and system 12

2.6 EUT Operation Test Setup 12

2.7 Measurement Results Explanation Example 13

3 TEST RESULT 14

3.1 6dB Bandwidth Measurement 14

3.2 Output Power Measurement 16

3.3 Power Spectral Density Measurement 18

3.4 Conducted Band Edges and Spurious Emission Measurement 20

3.5 Radiated Band Edges and Spurious Emission Measurement 30

3.6 AC Conducted Emission Measurement 34

3.7 Antenna Requirements 38

4 LIST OF MEASURING EQUIPMENT 39

5 UNCERTAINTY OF EVALUATION 40

APPENDIX A. CONDUCTED TEST RESULTS

APPENDIX B. RADIATED TEST RESULTS

APPENDIX C. DUTY CYCLE PLOTS

APPENDIX D. SETUP PHOTOGRAPHS



REVISION HISTORY

REPORT NO.	VERSION	DESCRIPTION	ISSUED DATE
FR662003C	Rev. 01	Initial issue of report	Sep. 23, 2016



SUMMARY OF TEST RESULT

Report Section	FCC Rule	Description	Limit	Result	Remark
3.1	15.247(a)(2)	6dB Bandwidth	$\geq 0.5\text{MHz}$	Pass	-
3.2	15.247(b)	Power Output Measurement	$\leq 30\text{dBm}$	Pass	-
3.3	15.247(e)	Power Spectral Density	$\leq 8\text{dBm}/3\text{kHz}$	Pass	-
3.4	15.247(d)	Conducted Band Edges	$\leq 20\text{dBc}$	Pass	-
		Conducted Spurious Emission		Pass	-
3.5	15.247(d)	Radiated Band Edges and Radiated Spurious Emission	15.209(a) & 15.247(d)	Pass	Under limit 6.05 dB at 2389.820 MHz
3.6	15.207	AC Conducted Emission	15.207(a)	Pass	Under limit 9.46 dB at 0.150 MHz
3.7	15.203 & 15.247(b)	Antenna Requirement	N/A	Pass	-



1 General Description

1.1 Applicant

Lenovo Mobile Communication Technology Ltd.

No.999, Qishan North 2nd Road, Information & Optoelectronics Park, Torch Hi-tech Industry Development Zone, Xiamen, P.R.China

1.2 Manufacturer

Motorola Mobility LLC

222 W.Merchandise Mart Plaza, Chicago IL 60654 USA

1.3 Product Feature of Equipment Under Test

Product Feature	
Equipment	Mobile Cellular Phone
Brand Name	Lenovo
Model Name	Lenovo K53a48
FCC ID	YCNK53A48
EUT supports Radios application	GSM/GPRS/EGPRS/WCDMA/HSPA/DC-HSDPA/ HSPA+ (16QAM uplink is not supported)/LTE/ WLAN 2.4GHz 802.11b/g/n HT20/ Bluetooth v3.0 + EDR/Bluetooth v4.0 LE / Bluetooth v4.2 LE
IMEI Code	Conducted:861576030071119/861576030071127 Conduction:861886030041636/861886030041644 Radiation: 861576030072497/861576030072505
HW Version	82939_1_13
SW Version	K53_S022_160815_ROW
EUT Stage	Identical Prototype

Remark: The above EUT's information was declared by manufacturer. Please refer to the specifications or user's manual for more detailed description.

1.4 Product Specification of Equipment Under Test

Standards-related Product Specification	
Tx/Rx Channel Frequency Range	2412 MHz ~ 2462 MHz
Maximum (Peak) Output Power to Antenna	802.11b : 15.96 dBm (0.0394 W) 802.11g : 21.77 dBm (0.1503 W) 802.11n HT20 : 21.13 dBm (0.1297 W)
Antenna Type / Gain	LDS Antenna with gain -4.87 dBi
Type of Modulation	802.11b : DSSS (DBPSK / DQPSK / CCK) 802.11g/n : OFDM (BPSK / QPSK / 16QAM / 64QAM)



1.5 Specification of Accessory

Specification of Accessory				
AC Adapter 1	Brand Name	Lenovo (Acbel)	Model Name	C-P35
	Power Rating	I/P: 100-240Vac, 300mA, O/P: 5.2Vdc, 2000mA		
AC Adapter 2	Brand Name	Lenovo (Huntkey)	Model Name	C-P35
	Power Rating	I/P: 100-240Vac, 500mA, O/P: 5.2Vdc, 2000mA		
Battery	Brand Name	Lenovo (SCUD)	Model Name	BL270
	Power Rating	3.85Vdc, 4000mAh		
Earphone	Brand Name	N/A	Model Name	NLD-EM127E-96SH-6
	Signal Line Type	1.1 meter, non-shielded cable, without ferrite core		
USB Cable	Brand Name	Lenovo(Starw)	Model Name	XJ-007070
	Signal Line Type	1.0 meter, non-shielded cable, without ferrite core		
LCD Panel	Brand Name	TIANMA	Model Name	TL055VDXP64-00
Camera_ Front	Brand Name	Q-Tech	Model Name	FX219BQS
Camera _ Rear	Brand Name	Sunny	Model Name	A16S05J-200
CTP Module	Brand Name	O-FILM	Model Name	Black : MCF-055-2594 White : MCF-055-2594-01 Golden : MCF-055-2594-02



1.6 Modification of EUT

No modifications are made to the EUT during all test items.

1.7 Testing Location

Test Site	SPORTON INTERNATIONAL (KUNSHAN) INC.			
Test Site Location	No. 3-2, PingXiang Road, Kunshan, Jiangsu Province, P. R. China TEL: +86-0512-5790-0158 FAX: +86-0512-5790-0958			
Test Site No.	Sporton Site No.			FCC Registration No.
	TH01-KS	03CH03-KS	CO01-KS	306251

Note: The test site complies with ANSI C63.4 2014 requirement.

1.8 Applicable Standards

According to the specifications of the manufacturer, the EUT must comply with the requirements of the following standards:

- FCC Part 15 Subpart C §15.247
- FCC KDB Publication No. 558074 D01 DTS Meas. Guidance v03r05
- ANSI C63.10-2013

Remark:

1. All test items were verified and recorded according to the standards and without any deviation during the test.
2. This EUT has also been tested and complied with the requirements of FCC Part 15, Subpart B, recorded in a separate test report.



2 Test Configuration of Equipment Under Test

The EUT has been associated with peripherals and configuration operated in a manner tended to maximize its emission characteristics in a typical application. Frequency range investigated: conducted emission (150 kHz to 30 MHz) and radiated emission (9 kHz to the 10th harmonic of the highest fundamental frequency or to 40 GHz, whichever is lower). For radiated measurement, pre-scanned in three orthogonal panels, X, Y, Z. The worst cases were recorded in this report.

2.1 Carrier Frequency Channel

Frequency Band	Channel	Freq. (MHz)	Channel	Freq. (MHz)
2400-2483.5 MHz	1	2412	7	2442
	2	2417	8	2447
	3	2422	9	2452
	4	2427	10	2457
	5	2432	11	2462
	6	2437	-	-



2.2 Pre-Scanned RF Power

Preliminary tests were performed in different data rate and data rate associated with the highest power were chosen for full test shown in the following tables.

Channel	Frequency	2.4GHz 802.11b RF Power (dBm)			
		DSSS Data Rate			
		1 Mbps	2 Mbps	5.5 Mbps	11 Mbps
CH 01	2412 MHz	15.96	15.77	15.84	15.95
CH 06	2437 MHz	14.48	14.25	14.32	14.46
CH 11	2462 MHz	14.60	14.33	14.45	14.58

Channel	Frequency	2.4GHz 802.11g RF Power (dBm)							
		OFDM Data Rate							
		6 Mbps	9 Mbps	12 Mbps	18 Mbps	24 Mbps	36 Mbps	48 Mbps	54 Mbps
CH 01	2412 MHz	21.77	21.66	21.71	21.57	21.54	21.59	21.65	21.55
CH 06	2437 MHz	20.81	20.73	20.65	20.65	20.56	20.54	20.76	20.77
CH 11	2462 MHz	20.55	20.52	20.48	20.45	20.39	20.34	20.30	20.41

Channel	Frequency	2.4GHz 802.11n HT20 RF Power (dBm)							
		OFDM Data Rate							
		MCS0	MCS1	MCS2	MCS3	MCS4	MCS5	MCS6	MCS7
CH 01	2412 MHz	21.13	21.10	21.12	21.08	21.07	20.87	21.02	21.08
CH 06	2437 MHz	20.09	19.98	19.88	19.97	20.05	19.87	19.95	19.99
CH 11	2462 MHz	19.86	19.81	19.78	19.82	19.79	19.77	19.77	19.69



2.3 Test Mode

Final test mode of conducted test items and radiated spurious emissions are considering the modulation and worse data rates from the power table described in section 2.2.

<2.4GHz>

Modulation	Data Rate
802.11b	1 Mbps
802.11g	6 Mbps
802.11n HT20	MCS0

Test Cases	
AC Conducted Emission	GSM850 Idle + Bluetooth Link + WLAN Link + Earphone + USB Cable (Charging from Adapter 1)
Remark: For radiated test cases, the tests were performed with adapter 1, earphone and USB cable.	

2.4 Connection Diagram of Test System

<WLAN Tx Mode>

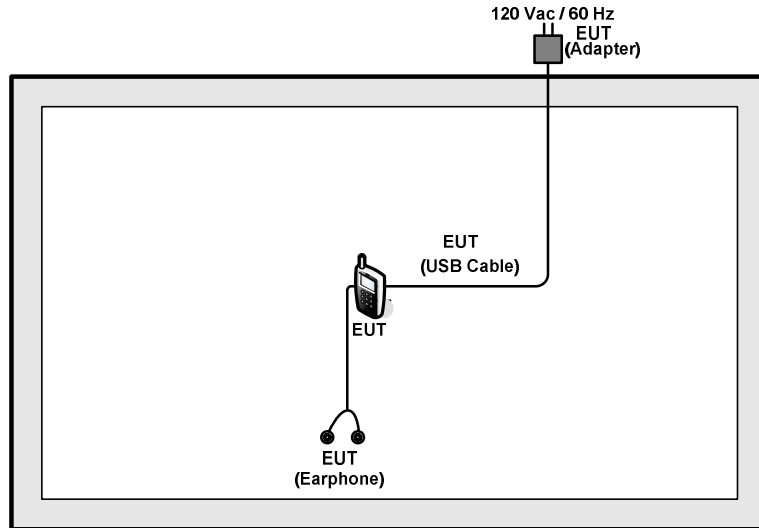

<AC Conducted Emission Mode>

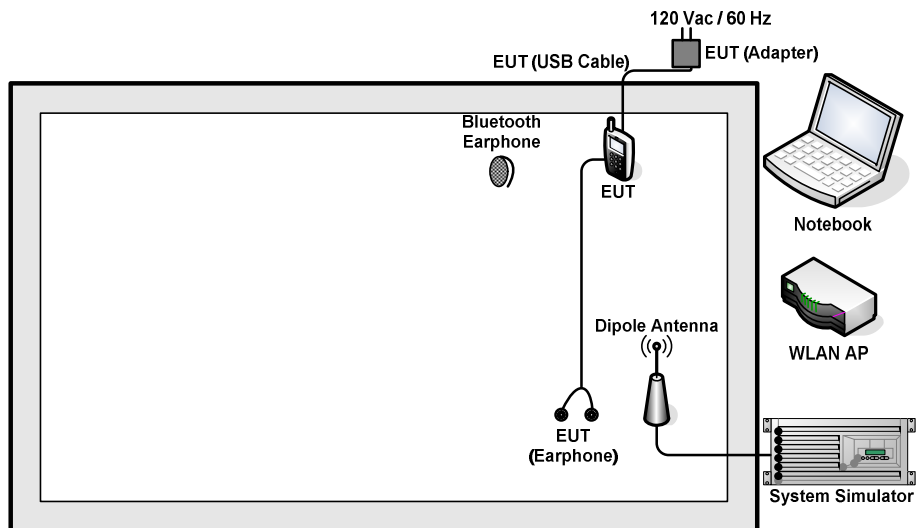

2.5 Support Unit used in test configuration and system

Item	Equipment	Trade Name	Model Name	FCC ID	Data Cable	Power Cord
1.	System Simulator	Anritus	MT8820C	N/A	N/A	Unshielded, 1.8 m
2.	WLAN AP	LINKSYS	WRT600N	Q87-WRT600NV11	N/A	Unshielded, 1.8 m
3.	Notebook	Lenovo	G480	PRC4	N/A	AC I/P: Unshielded, 1.8 m DC O/P: Shielded, 1.8 m
4.	Bluetooth Earphone	Lenovo	LBH308	N/A	N/A	N/A

2.6 EUT Operation Test Setup

For WLAN function, the engineering test program was provided and enabled to make EUT continuous transmit/receive.

For AC power line conducted emissions, the EUT was set to connect with the WLAN AP under large package sizes transmission.



2.7 Measurement Results Explanation Example

For all conducted test items:

The offset level is set in the spectrum analyzer to compensate the RF cable loss between EUT conducted output port and spectrum analyzer. With the offset compensation, the spectrum analyzer reading level is exactly the EUT RF output level.

Example :

The spectrum analyzer offset is derived from RF cable loss.

Offset = RF cable loss

Following shows an offset computation example with cable loss 5.9 dB

$$\begin{aligned} \text{Offset(dB)} &= \text{RF cable loss(dB)} \\ &= 5.9 \text{ (dB)} \end{aligned}$$

3 Test Result

3.1 6dB Bandwidth Measurement

3.1.1 Limit of 6dB Bandwidth

The minimum 6 dB bandwidth shall be at least 500 kHz.

3.1.2 Measuring Instruments

The measuring equipment is listed in the section 4 of this test report.

3.1.3 Test Procedures

1. The testing follows FCC KDB Publication No. 558074 DTS D01 Meas. Guidance v03r05.
2. The RF output of EUT was connected to the spectrum analyzer by RF cable and attenuator. The path loss was compensated to the results for each measurement.
3. Set to the maximum power setting and enable the EUT transmit continuously.
4. Make the measurement with the spectrum analyzer's resolution bandwidth (RBW) = 100 kHz. Set the Video bandwidth (VBW) = 300 kHz. In order to make an accurate measurement. The 6 dB bandwidth must be greater than 500 kHz.
5. Measure and record the results in the test report.

3.1.4 Test Setup

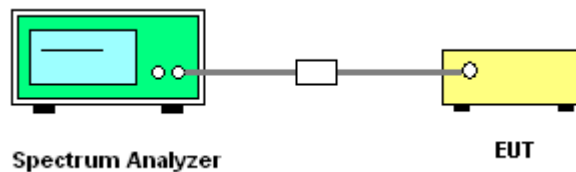



3.1.5 Test Result of 6dB

Please refer to Appendix A of this test report.

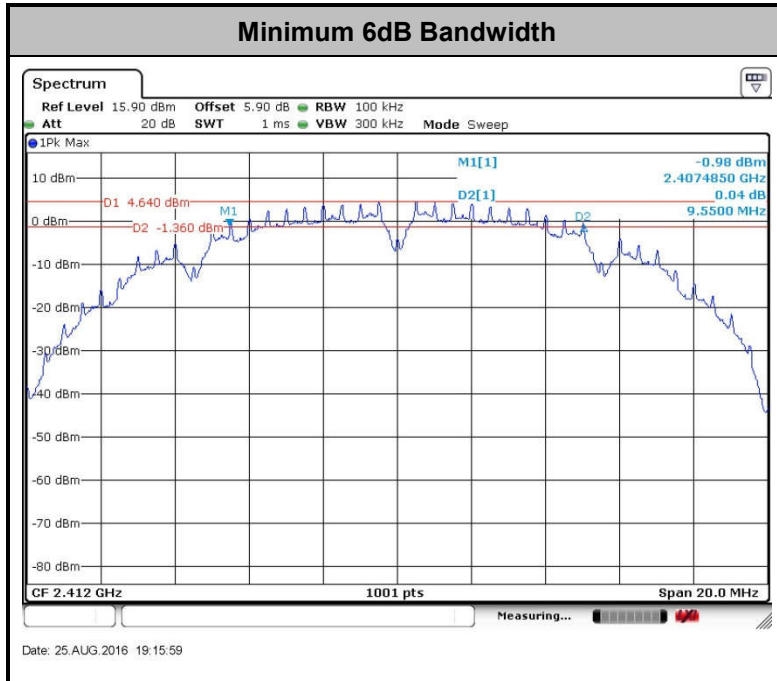

Note : The occupied channel bandwidth is maintained within the band of operation for all of the modulations.

3.2 Output Power Measurement

3.2.1 Limit of Output Power

For systems using digital modulation in the 2400-2483.5MHz, the limit for peak output power is 30dBm. If transmitting Antenna of directional gain greater than 6dBi are used the peak output power from the intentional radiator shall be reduced below the above stated value by the amount in dB that the directional gain of the Antenna exceeds 6 dBi. In case of point-to-point operation, the limit has to be reduced by 1dB for every 3dB that the directional gain of the Antenna exceeds 6dBi.

3.2.2 Measuring Instruments

The measuring equipment is listed in the section 4 of this test report.

3.2.3 Test Procedures

1. The testing follows the Measurement Procedure of FCC KDB No. 558074 DTS D01 Meas. Guidance v03r05 section 9.1.2 PKPM1 Peak power meter method.
2. The RF output of EUT was connected to the power meter by RF cable and attenuator. The path loss was compensated to the results for each measurement.
3. Set to the maximum power setting and enable the EUT transmit continuously.
4. Measure the conducted output power and record the results in the test report.

3.2.4 Test Setup

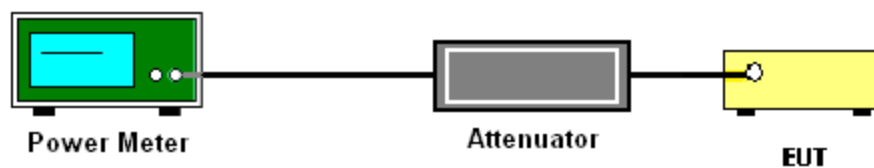



3.2.5 Test Result of Peak Output Power

Please refer to Appendix A of this test report.

3.2.6 Test Result of Average output Power (Reporting Only)

Please refer to Appendix A of this test report.

3.3 Power Spectral Density Measurement

3.3.1 Limit of Power Spectral Density

The peak power spectral density shall not be greater than 8dBm in any 3kHz band at any time interval of continuous transmission.

3.3.2 Measuring Instruments

The measuring equipment is listed in the section 4 of this test report.

3.3.3 Test Procedures

1. The testing follows Measurement Procedure 10.2 Method PKPSD of FCC KDB Publication No. 558074 D01 DTS Meas. Guidance v03r05
2. The RF output of EUT was connected to the spectrum analyzer by RF cable and attenuator. The path loss was compensated to the results for each measurement.
3. Set to the maximum power setting and enable the EUT transmit continuously.
4. Make the measurement with the spectrum analyzer's resolution bandwidth (RBW) = 3 kHz. Video bandwidth VBW = 10 kHz In order to make an accurate measurement, set the span to 1.5 times DTS Channel Bandwidth. (6dB BW)
5. Detector = peak, Sweep time = auto couple, Trace mode = max hold, Allow trace to fully stabilize. Use the peak marker function to determine the maximum power level.
6. Measure and record the results in the test report.

3.3.4 Test Setup

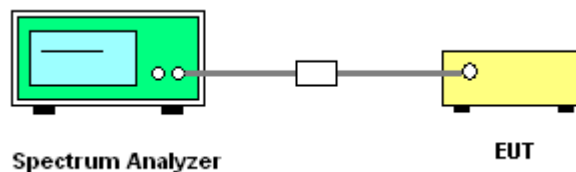



3.3.5 Test Result of Power Spectral Density

Please refer to Appendix A of this test report.

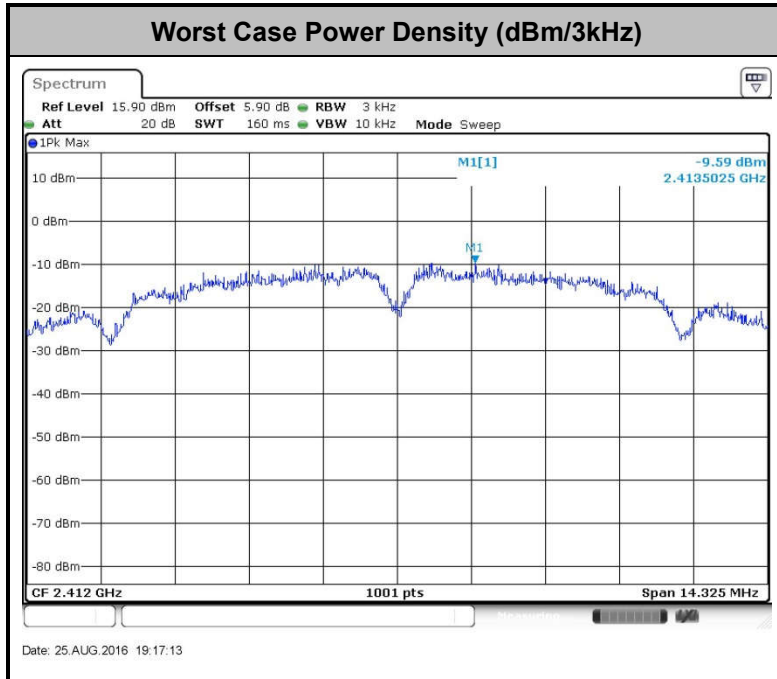

3.4 Conducted Band Edges and Spurious Emission Measurement

3.4.1 Limit of Conducted Band Edges and Spurious Emission Measurement

In any 100 kHz bandwidth outside of the authorized frequency band, the emissions which fall in the non-restricted bands shall be attenuated at least 20 dB / 30dB relative to the maximum PSD level in 100 kHz by RF conducted measurement and radiated emissions which fall in the restricted bands, as defined in Section 15.205(a), must also comply with the radiated emission limits specified in Section 15.209(a).

3.4.2 Measuring Instruments

The measuring equipment is listed in the section 4 of this test report.

3.4.3 Test Procedures

1. The testing follows FCC KDB Publication No. 558074 D01 DTS Meas. Guidance v03r05.
2. The RF output of EUT was connected to the spectrum analyzer by RF cable and attenuator. The path loss was compensated to the results for each measurement.
3. Set to the maximum power setting and enable the EUT transmit continuously.
4. Set RBW = 100 kHz, VBW=300 kHz, Peak Detector. Unwanted Emissions measured in any 100 kHz bandwidth outside of the authorized frequency band shall be attenuated by at least 20 dB relative to the maximum in-band peak PSD level in 100 kHz when maximum peak conducted output power procedure is used. If the transmitter complies with the conducted power limits based on the use of RMS averaging over a time interval, the attenuation required under this paragraph shall be 30 dB instead of 20 dB per 15.247(d).
5. Measure and record the results in the test report.
6. The RF fundamental frequency should be excluded against the limit line in the operating frequency band.

3.4.4 Test Setup

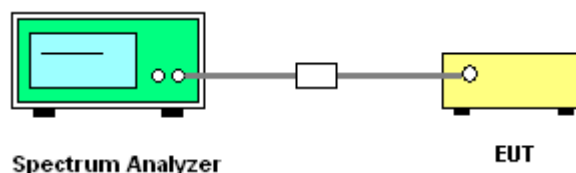



3.4.5 Test Result of Conducted Band Edges and Spurious Emission

Test Mode :	802.11b	Temperature :	24~25°C
Test Band :	2.4GHz Low	Relative Humidity :	50~55%
Test Channel :	01	Test Engineer :	Silent Hai

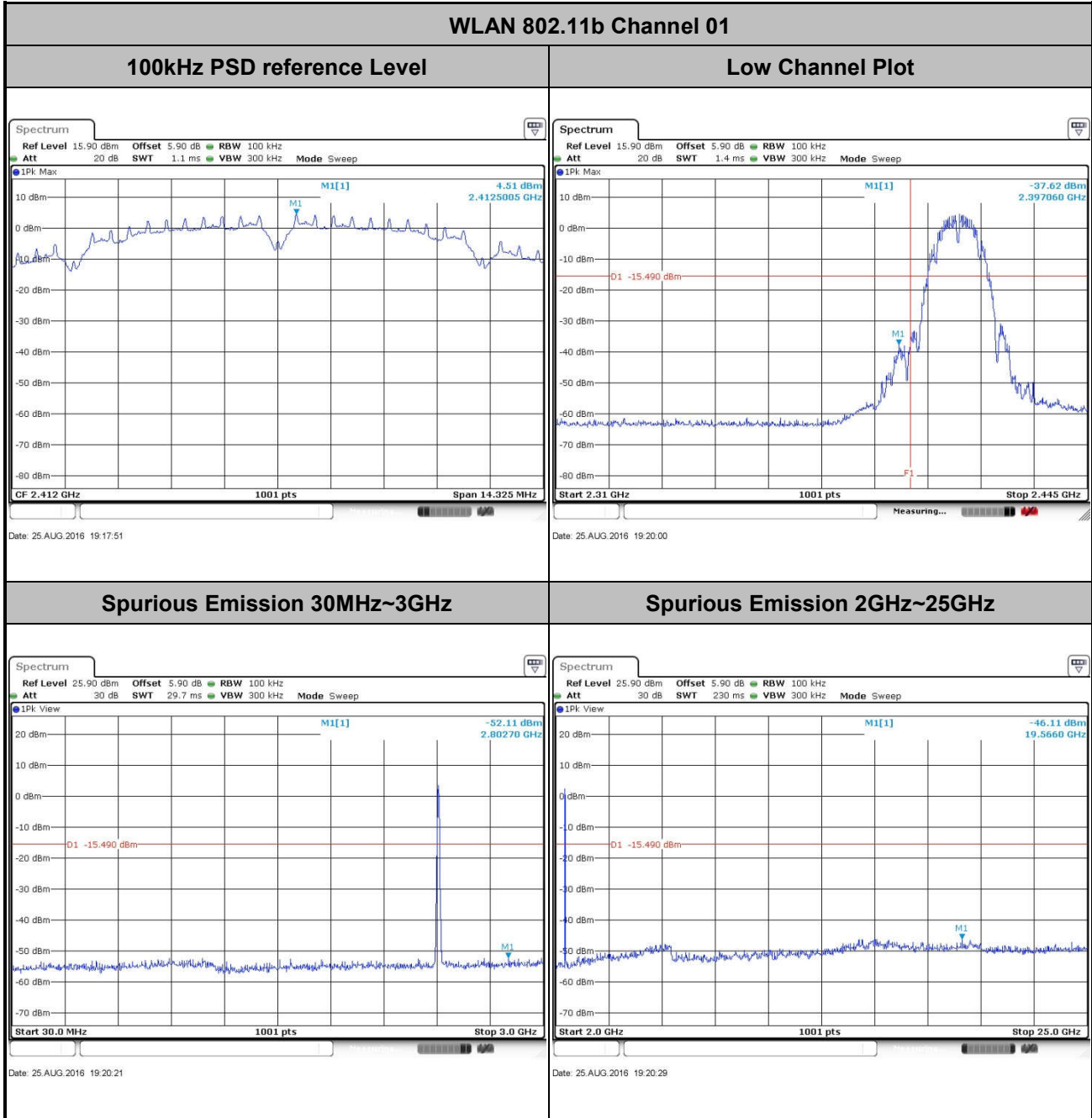



Test Mode :	802.11b	Temperature :	24~25°C
Test Band :	2.4GHz Mid	Relative Humidity :	50~55%
Test Channel :	06	Test Engineer :	Silent Hai

WLAN 802.11b Channel 06

100kHz PSD reference Level

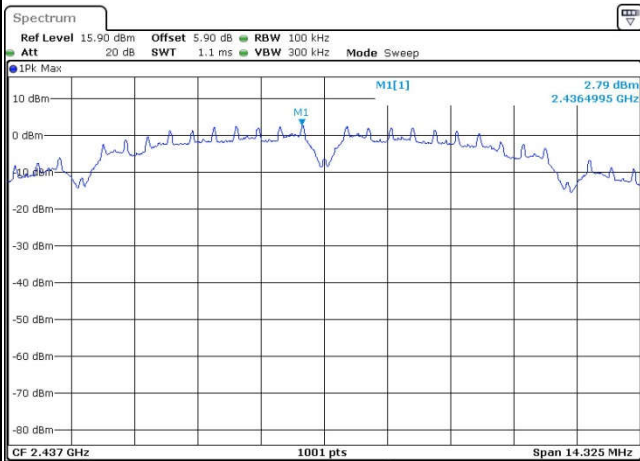

Date: 25.AUG.2016 19:26:55

Spurious Emission 30MHz~3GHz

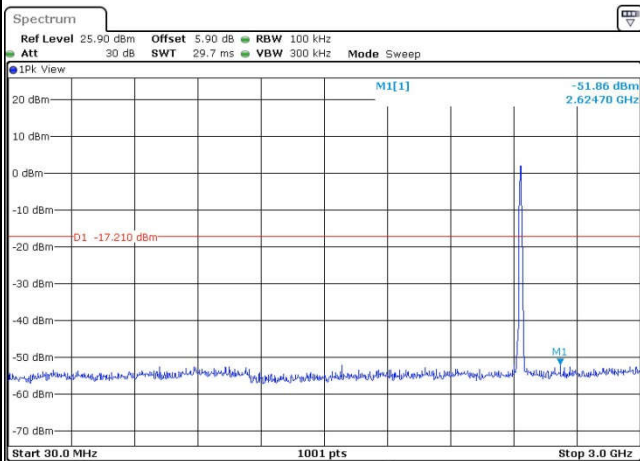

Date: 25.AUG.2016 19:27:06

Spurious Emission 2GHz~25GHz

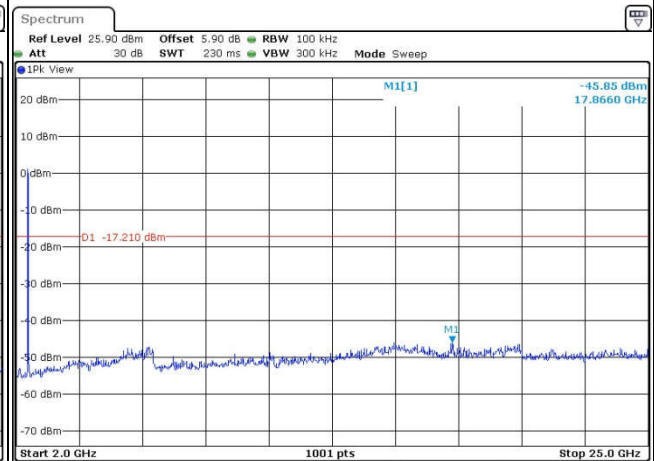

Date: 25.AUG.2016 19:27:14



Test Mode :	802.11b	Temperature :	24~25°C
Test Band :	2.4GHz High	Relative Humidity :	50~55%
Test Channel :	11	Test Engineer :	Silent Hai

WLAN 802.11b Channel 11

100kHz PSD reference Level

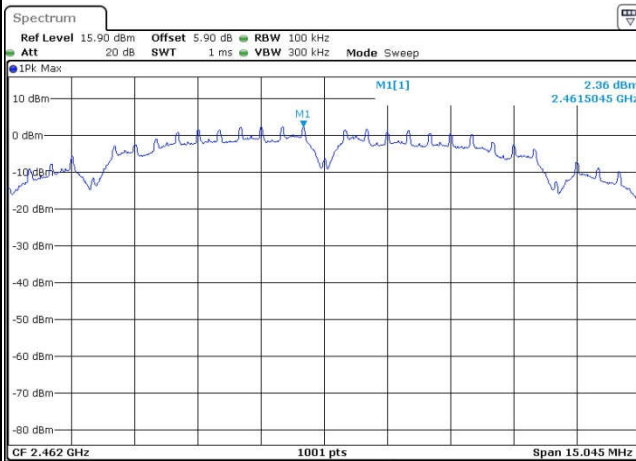

Date: 25.AUG.2016 19:30:00

High Channel Plot

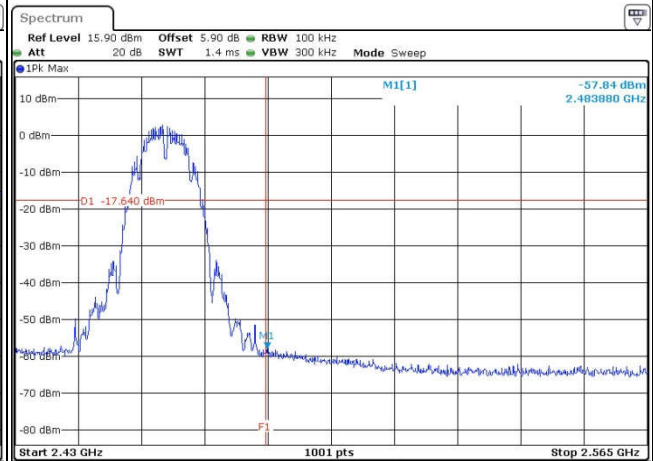

Date: 25.AUG.2016 19:30:14

Spurious Emission 30MHz~3GHz

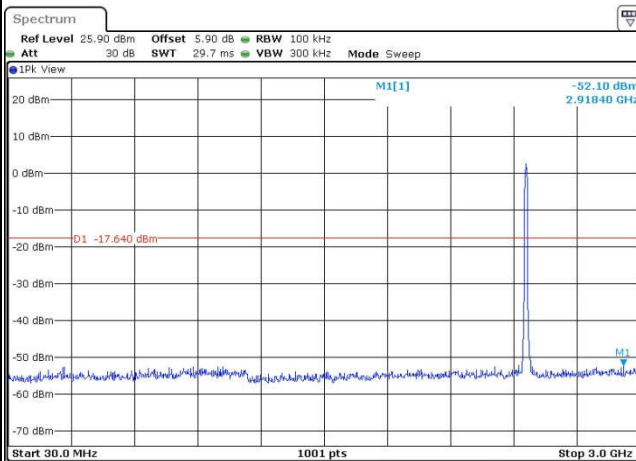

Date: 25.AUG.2016 19:30:39

Spurious Emission 2GHz~25GHz

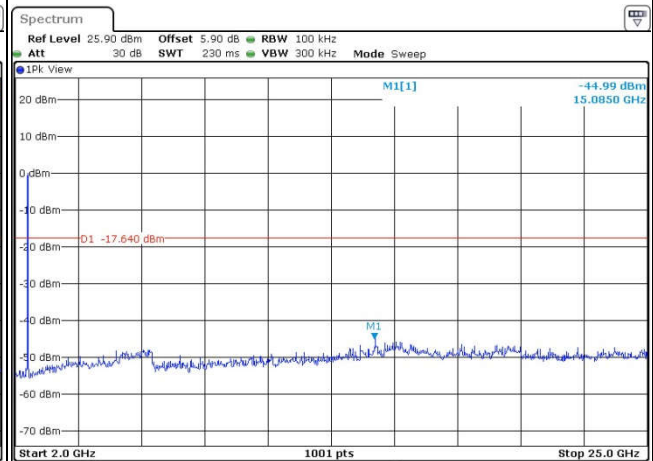

Date: 25.AUG.2016 19:30:48



Test Mode :	802.11g	Temperature :	24~25°C
Test Band :	2.4GHz Low	Relative Humidity :	50~55%
Test Channel :	01	Test Engineer :	Silent Hai

WLAN 802.11g Channel 01

100kHz PSD reference Level

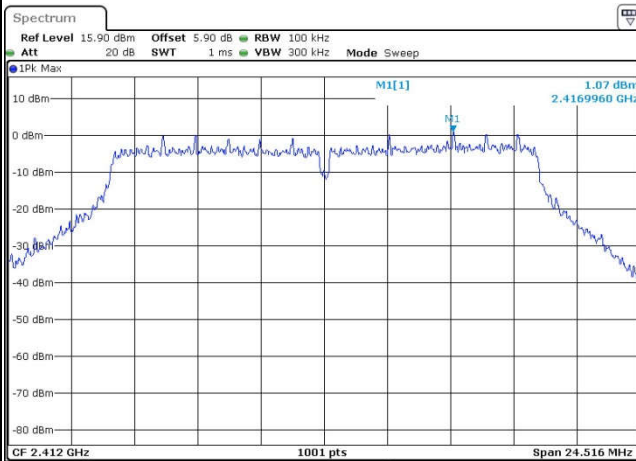

Date: 25.AUG.2016 19:34:08

Low Channel Plot

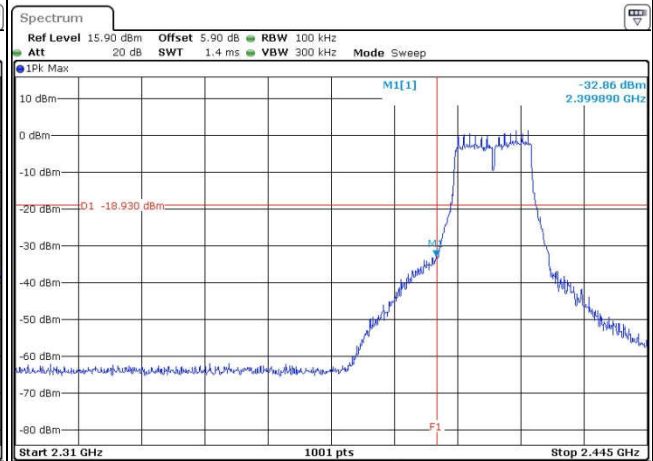

Date: 25.AUG.2016 19:34:23

Spurious Emission 30MHz~3GHz

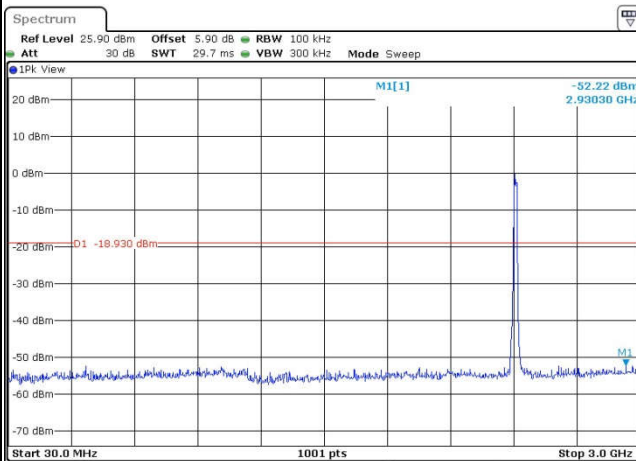

Date: 25.AUG.2016 19:34:36

Spurious Emission 2GHz~25GHz

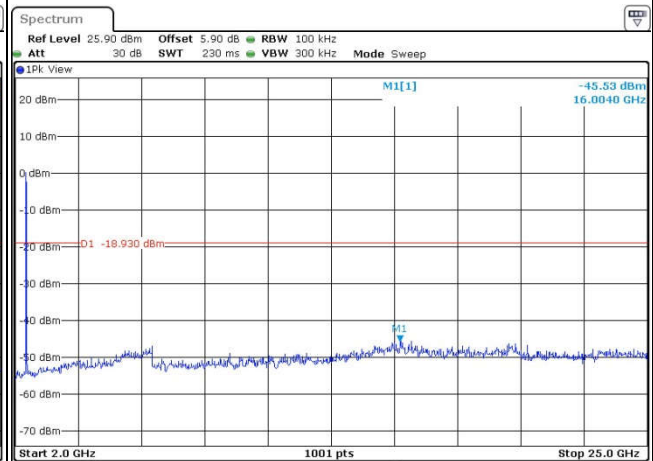

Date: 25.AUG.2016 19:34:45



Test Mode :	802.11g	Temperature :	24~25°C
Test Band :	2.4GHz Mid	Relative Humidity :	50~55%
Test Channel :	06	Test Engineer :	Silent Hai

WLAN 802.11g Channel 06

100kHz PSD reference Level

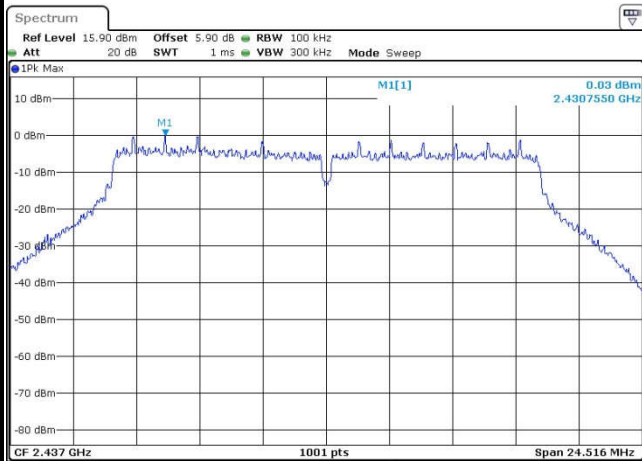

Date: 25.AUG.2016 19:37:27

Spurious Emission 30MHz~3GHz

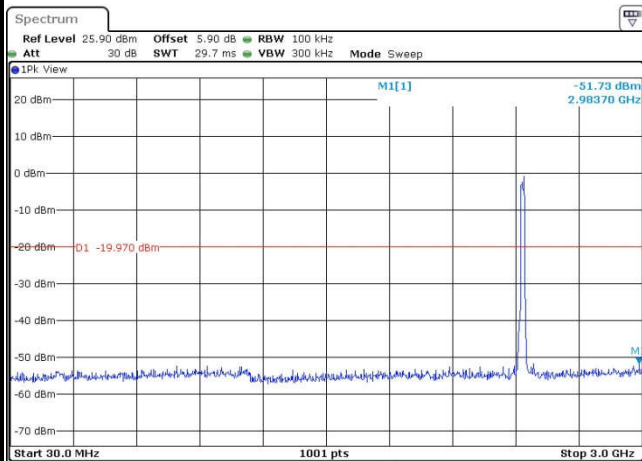

Date: 25.AUG.2016 19:37:36

Spurious Emission 2GHz~25GHz

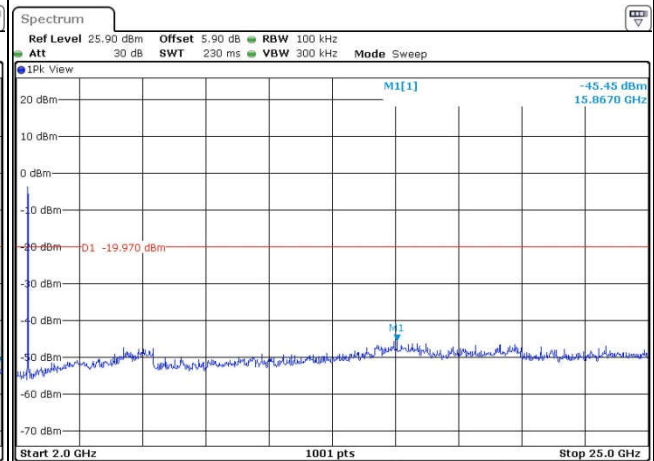

Date: 25.AUG.2016 19:37:44



Test Mode :	802.11g	Temperature :	24~25°C
Test Band :	2.4GHz High	Relative Humidity :	50~55%
Test Channel :	11	Test Engineer :	Silent Hai

WLAN 802.11g Channel 11

100kHz PSD reference Level

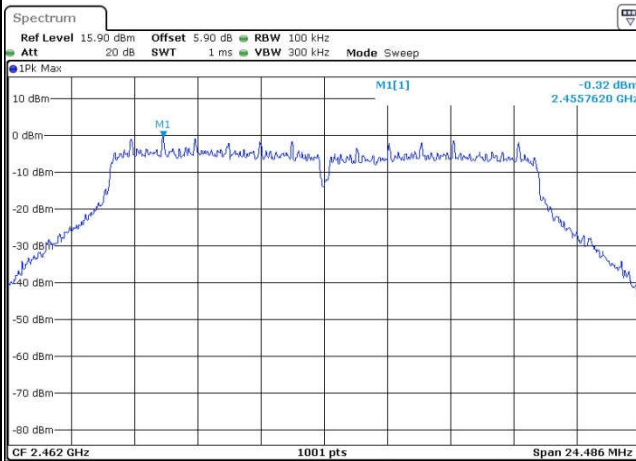

Date: 25.AUG.2016 19:39:56

High Channel Plot

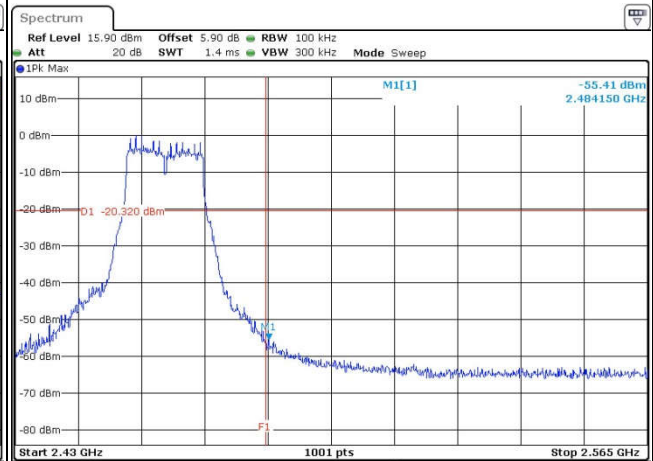

Date: 25.AUG.2016 19:40:08

Spurious Emission 30MHz~3GHz

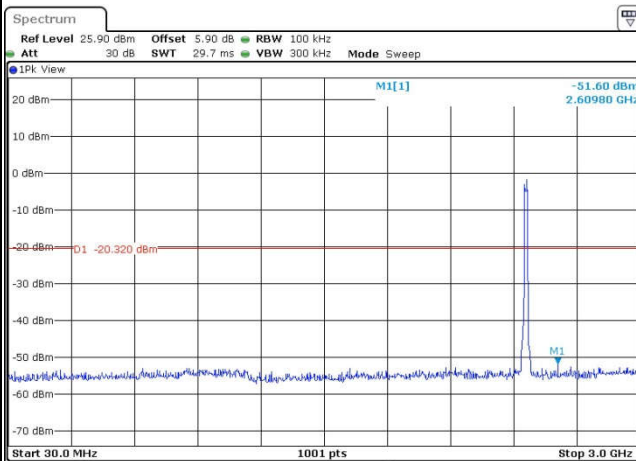

Date: 25.AUG.2016 19:40:23

Spurious Emission 2GHz~25GHz

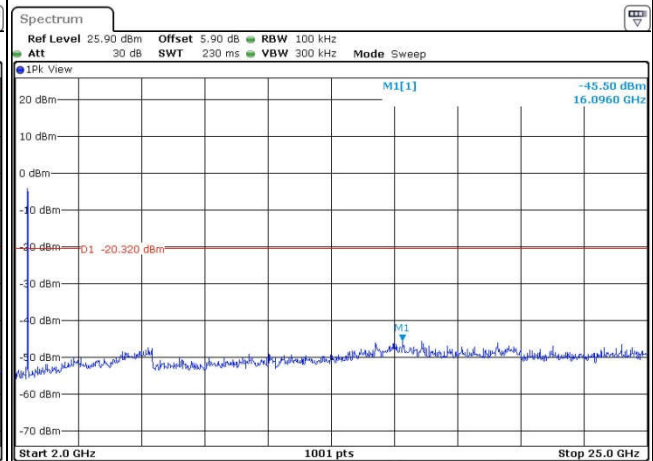

Date: 25.AUG.2016 19:40:32



Test Mode :	802.11n HT20	Temperature :	24~25°C
Test Band :	2.4GHz Low	Relative Humidity :	50~55%
Test Channel :	01	Test Engineer :	Silent Hai

WLAN 802.11n HT20 Channel 01

100kHz PSD reference Level

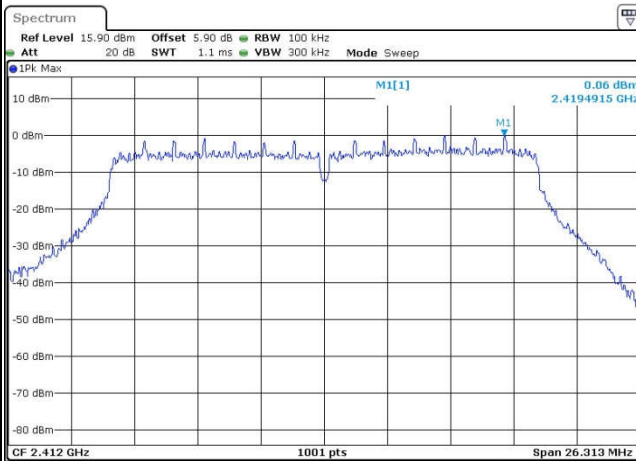

Date: 25.AUG.2016 19:43:20

Low Channel Plot

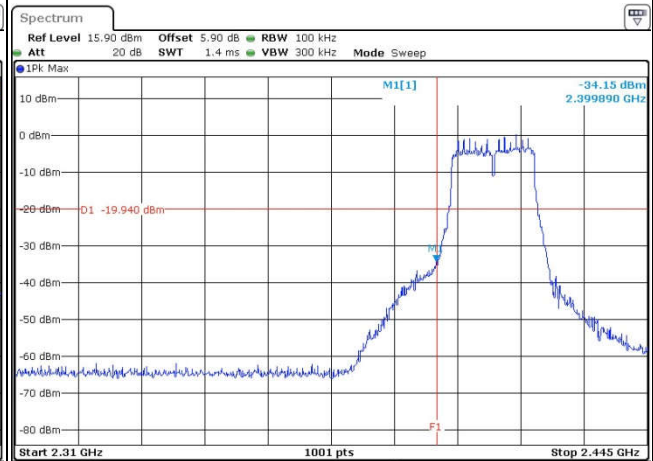

Date: 25.AUG.2016 19:43:31

Spurious Emission 30MHz~3GHz

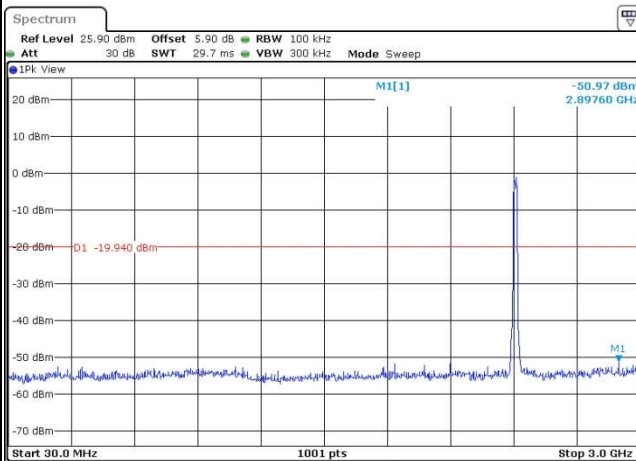

Date: 25.AUG.2016 19:43:44

Spurious Emission 2GHz~25GHz

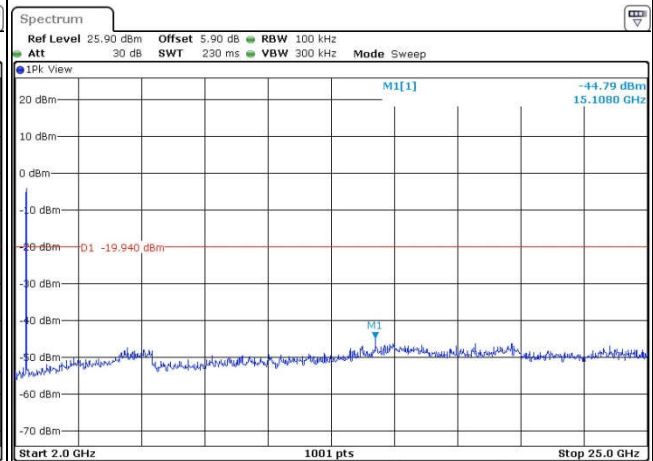

Date: 25.AUG.2016 19:43:52



Test Mode :	802.11n HT20	Temperature :	24~25°C
Test Band :	2.4GHz Mid	Relative Humidity :	50~55%
Test Channel :	06	Test Engineer :	Silent Hai

WLAN 802.11n HT20 Channel 06

100kHz PSD reference Level

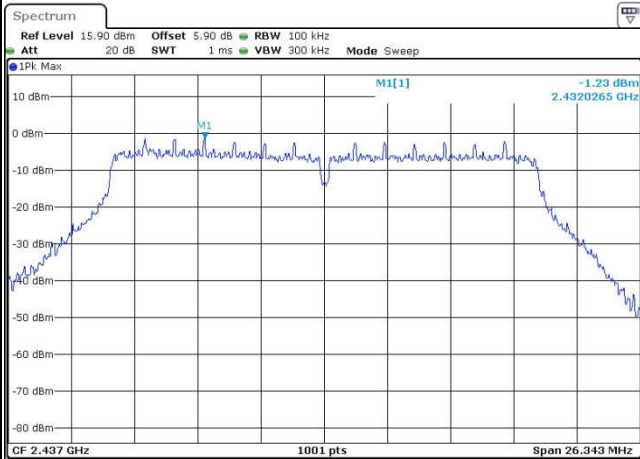

Date: 25.AUG.2016 19:46:40

Spurious Emission 30MHz~3GHz

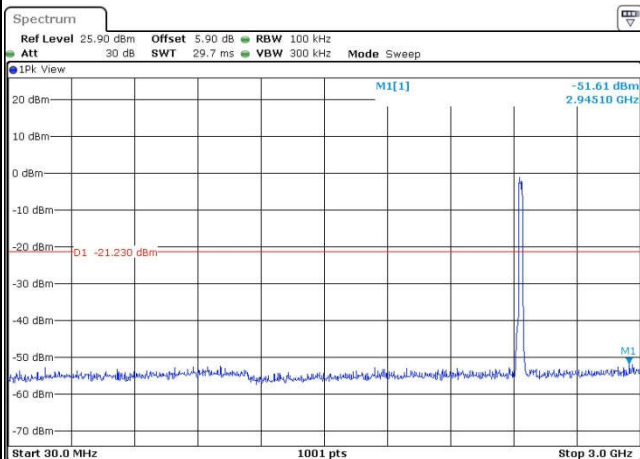

Date: 25.AUG.2016 19:47:23

Spurious Emission 2GHz~25GHz

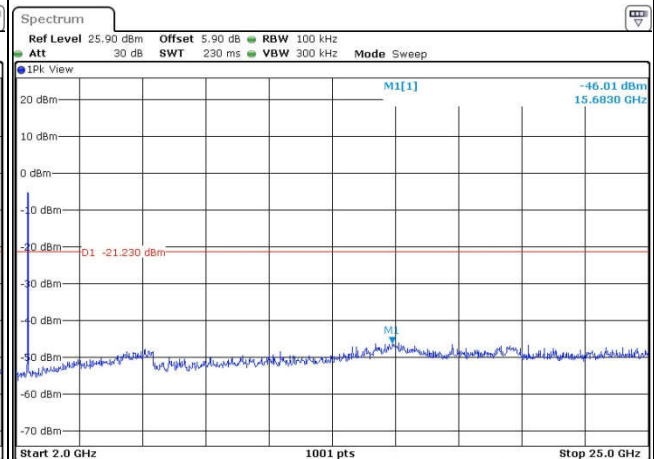

Date: 25.AUG.2016 19:47:31



Test Mode :	802.11n HT20	Temperature :	24~25°C
Test Band :	2.4GHz High	Relative Humidity :	50~55%
Test Channel :	11	Test Engineer :	Silent Hai

WLAN 802.11n HT20 Channel 11

100kHz PSD reference Level

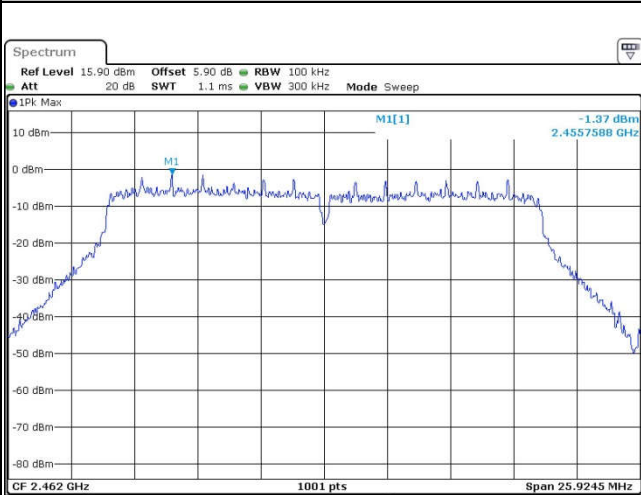

Date: 25.AUG.2016 19:50:00

High Channel Plot

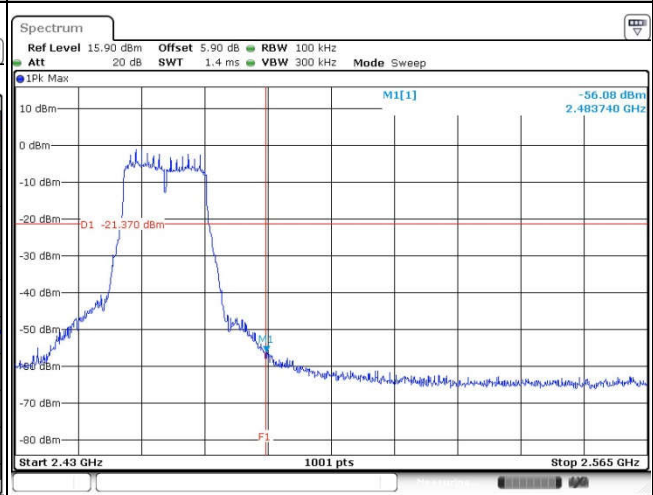

Date: 25.AUG.2016 19:50:12

Spurious Emission 30MHz~3GHz

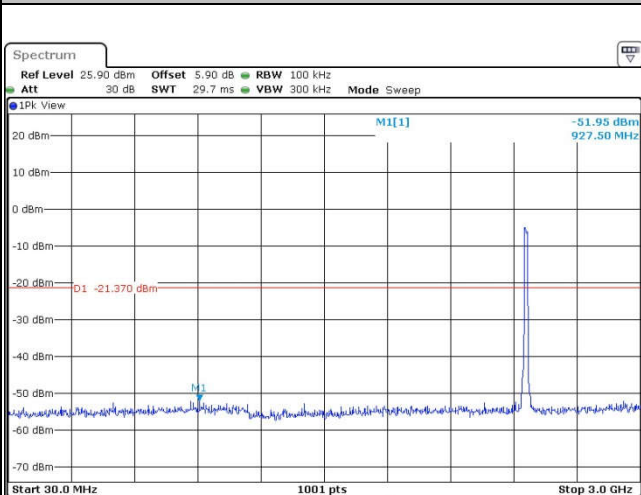

Date: 25.AUG.2016 19:52:15

Spurious Emission 2GHz~25GHz

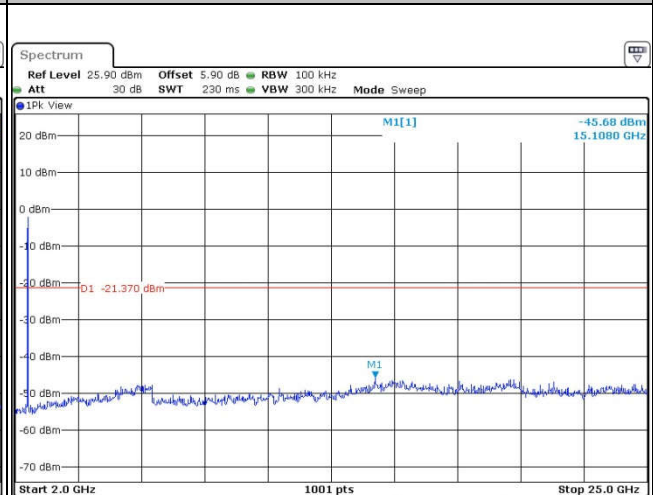

Date: 25.AUG.2016 19:52:23



3.5 Radiated Band Edges and Spurious Emission Measurement

3.5.1 Limit of Radiated band edge and Spurious Emission Measurement

In any 100 kHz bandwidth outside the intentional radiator frequency band, all harmonics/spurious must be at least 20 dB below the highest emission level within the authorized band. If the output power of this device was measured by spectrum analyzer, the attenuation under this paragraph shall be 30 dB instead of 20 dB. In addition, radiated emissions which fall in the restricted bands must also comply with the FCC section 15.209 limits as below.

Frequency (MHz)	Field Strength (microvolts/meter)	Measurement Distance (meters)
0.009 – 0.490	2400/F(kHz)	300
0.490 – 1.705	24000/F(kHz)	30
1.705 – 30.0	30	30
30 – 88	100	3
88 – 216	150	3
216 - 960	200	3
Above 960	500	3

3.5.2 Measuring Instruments

The measuring equipment is listed in the section 4 of this test report.



3.5.3 Test Procedures

1. The testing follows FCC KDB Publication No. 558074 D01 DTS Meas. Guidance v03r05.
2. The EUT was arranged to its worst case and then tune the antenna tower (from 1 m to 4 m) and turntable (from 0 degree to 360 degrees) to find the maximum reading. A pre-amp and a high pass filter are used for the test in order to get better signal level.
3. The EUT was placed on a turntable with 0.8 meter for frequency below 1GHz and 1.5 meter for frequency above 1GHz respectively above ground.
4. The EUT was set 3 meters from the interference receiving antenna, which was mounted on the top of a variable height antenna tower.
5. Corrected Reading: Antenna Factor + Cable Loss + Read Level - Preamp Factor = Level
6. For measurement below 1GHz, If the emission level of the EUT measured by the peak detector is 3 dB lower than the applicable limit, the peak emission level will be reported. Otherwise, the emission measurement will be repeated using the quasi-peak detector and reported.
7. Use the following spectrum analyzer settings:
 - (1) Span shall wide enough to fully capture the emission being measured;
 - (2) Set RBW=100 kHz for $f < 1$ GHz; VBW \geq RBW; Sweep = auto; Detector function = peak; Trace = max hold;
 - (3) Set RBW = 1 MHz, VBW= 3MHz for $f \geq 1$ GHz for peak measurement.
For average measurement:
 - VBW = 10 Hz, when duty cycle is no less than 98 percent.
 - VBW $\geq 1/T$, when duty cycle is less than 98 percent where T is the minimum transmission duration over which the transmitter is on and is transmitting at its maximum power control level for the tested mode of operation.

3.5.4 Test Setup

For radiated emissions below 30MHz

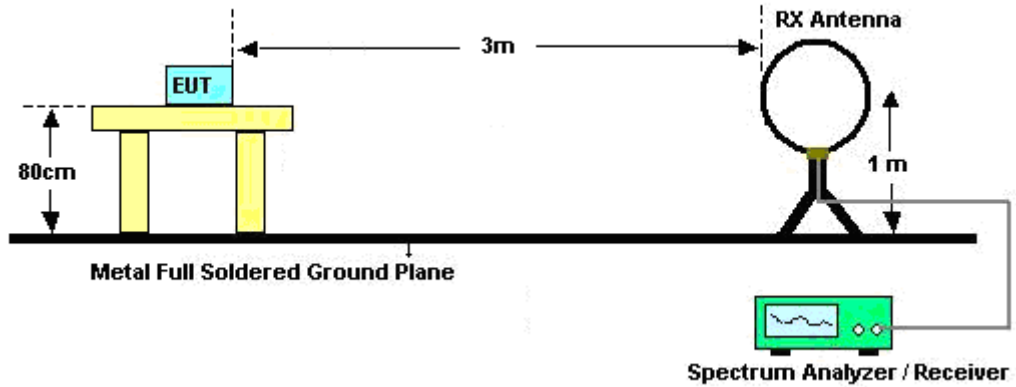

For radiated emissions from 30MHz to 1GHz

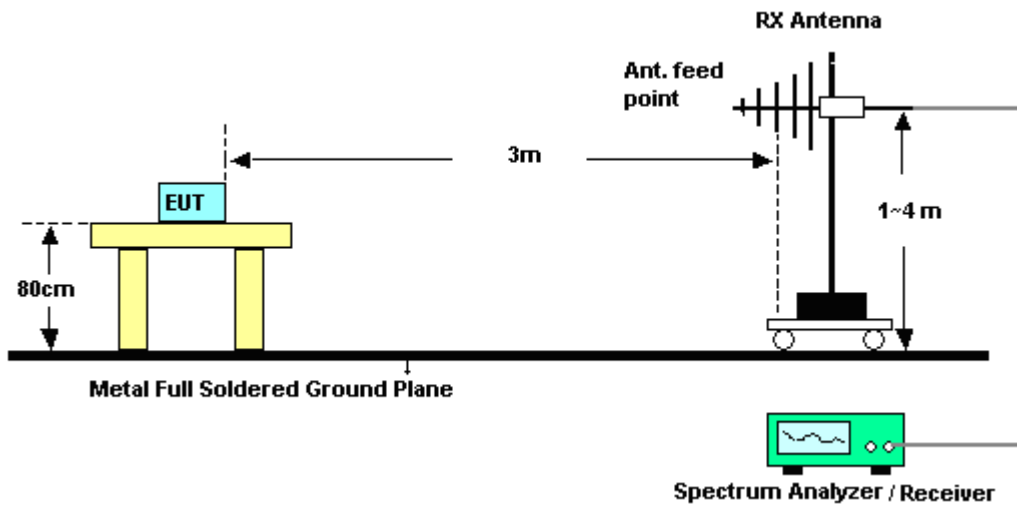

For radiated emissions above 1GHz

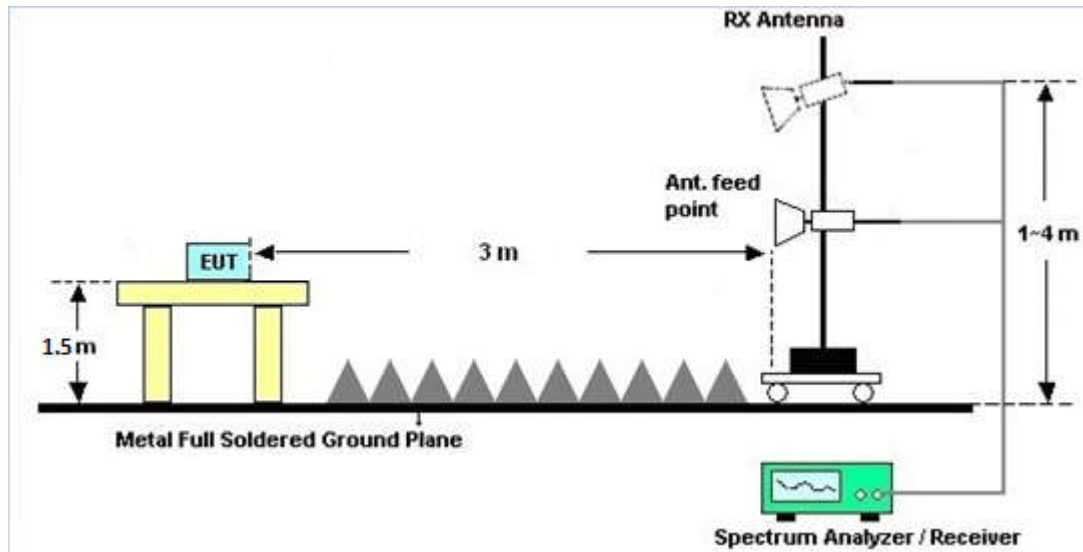

3.5.5 Test Results of Radiated Spurious Emissions (9kHz ~ 30MHz)

The low frequency, which started from 9 kHz to 30MHz, was pre-scanned and the result which was 20dB lower than the limit line per 15.31(o) was not reported.

3.5.6 Test Result of Radiated Spurious at Band Edges

Please refer to Appendix B.

3.5.7 Duty Cycle

Please refer to Appendix C.

3.5.8 Test Result of Radiated Spurious Emission (30MHz ~ 10th Harmonic)

Please refer to Appendix B.



3.6 AC Conducted Emission Measurement

3.6.1 Limit of AC Conducted Emission

For equipment that is designed to be connected to the public utility (AC) power line, the radio frequency voltage that is conducted back onto the AC power line on any frequency or frequencies within the band 150 kHz to 30 MHz shall not exceed the limits in the following table.

Frequency of Emission (MHz)	Conducted Limit (dB μ V)	
	Quasi-Peak	Average
0.15-0.5	66 to 56*	56 to 46*
0.5-5	56	46
5-30	60	50

*Decreases with the logarithm of the frequency.

3.6.2 Measuring Instruments

The measuring equipment is listed in the section 4 of this test report.

3.6.3 Test Procedures

1. The EUT was placed 0.4 meter from the conducting wall of the shielding room, and it was kept at least 80 centimeters from any other grounded conducting surface.
2. Connect EUT to the power mains through a line impedance stabilization network (LISN).
3. All the support units are connecting to the other LISN.
4. The LISN provides 50 ohm coupling impedance for the measuring instrument.
5. The FCC states that a 50 ohm, 50 microhenry LISN should be used.
6. Both sides of AC line were checked for maximum conducted interference.
7. The frequency range from 150 kHz to 30 MHz was searched.
8. Set the test-receiver system to Peak Detect Function and specified bandwidth (IF bandwidth = 9kHz) with Maximum Hold Mode.

3.6.4 Test Setup

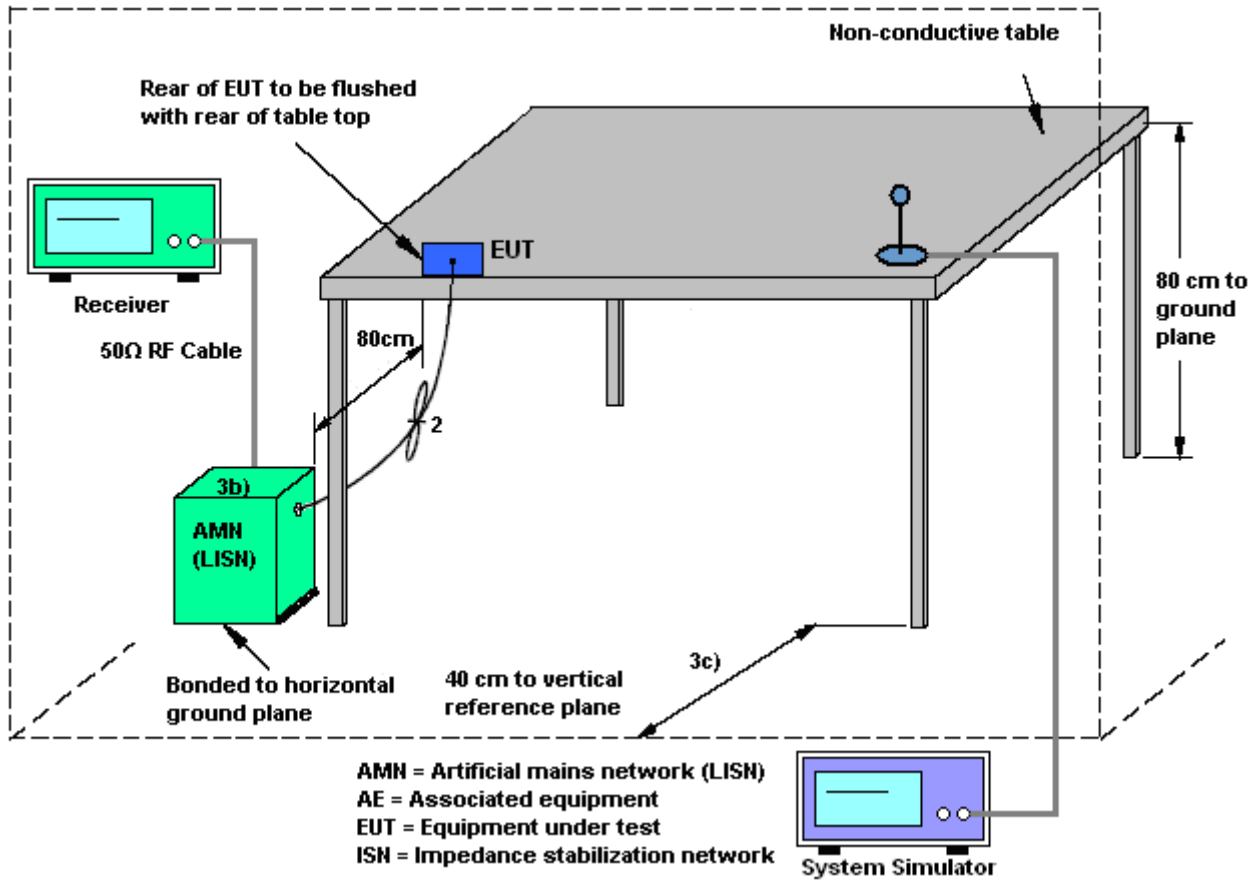



3.6.5 Test Result of AC Conducted Emission

Test Mode :	Mode 1	Temperature :	21~22°C
Test Engineer :	Rich Sun	Relative Humidity :	41~42%
Test Voltage :	120Vac / 60Hz	Phase :	Line
Function Type :	GSM850 Idle + Bluetooth Link + WLAN Link + Earphone + USB Cable (Charging from Adapter 1)		

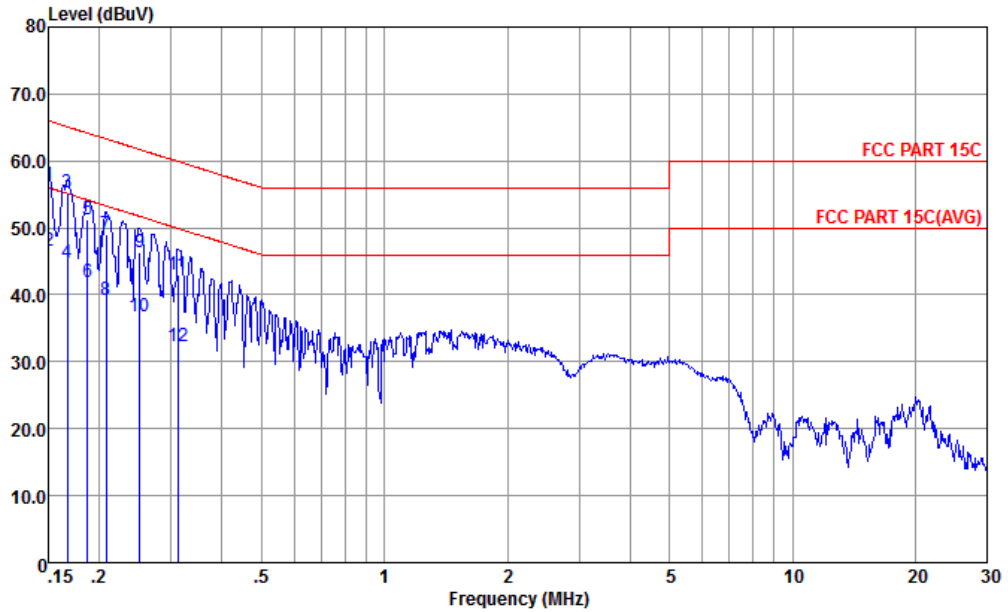

Site : CO01-KS
 Condition : FCC PART 15C LISN-L-20151024 LINE

mode : Mode 1
 IMEI : 861886030041636/861886030041644 #16

	Freq	Level	Over Limit	Limit Line	Read Level	LISN Factor	Cable Loss	Remark
	MHz	dBuV	dB	dBuV	dBuV	dB	dB	
1	0.150	56.44	-9.56	66.00	45.80	0.53	10.11	QP
2 *	0.150	46.54	-9.46	56.00	35.90	0.53	10.11	Average
3	0.167	55.23	-9.89	65.12	44.70	0.41	10.12	QP
4	0.167	44.73	-10.39	55.12	34.20	0.41	10.12	Average
5	0.187	51.21	-12.94	64.15	40.80	0.29	10.12	QP
6	0.187	41.81	-12.34	54.15	31.40	0.29	10.12	Average
7	0.208	48.95	-14.32	63.27	38.60	0.22	10.13	QP
8	0.208	39.25	-14.02	53.27	28.90	0.22	10.13	Average
9	0.251	46.26	-15.47	61.73	35.90	0.22	10.14	QP
10	0.251	36.86	-14.87	51.73	26.50	0.22	10.14	Average
11	0.312	42.97	-16.96	59.93	32.60	0.22	10.15	QP
12	0.312	32.27	-17.66	49.93	21.90	0.22	10.15	Average



Test Mode :	Mode 1	Temperature :	21~22°C
Test Engineer :	Rich Sun	Relative Humidity :	41~42%
Test Voltage :	120Vac / 60Hz	Phase :	Neutral
Function Type :	GSM850 Idle + Bluetooth Link + WLAN Link + Earphone + USB Cable (Charging from Adapter 1)		

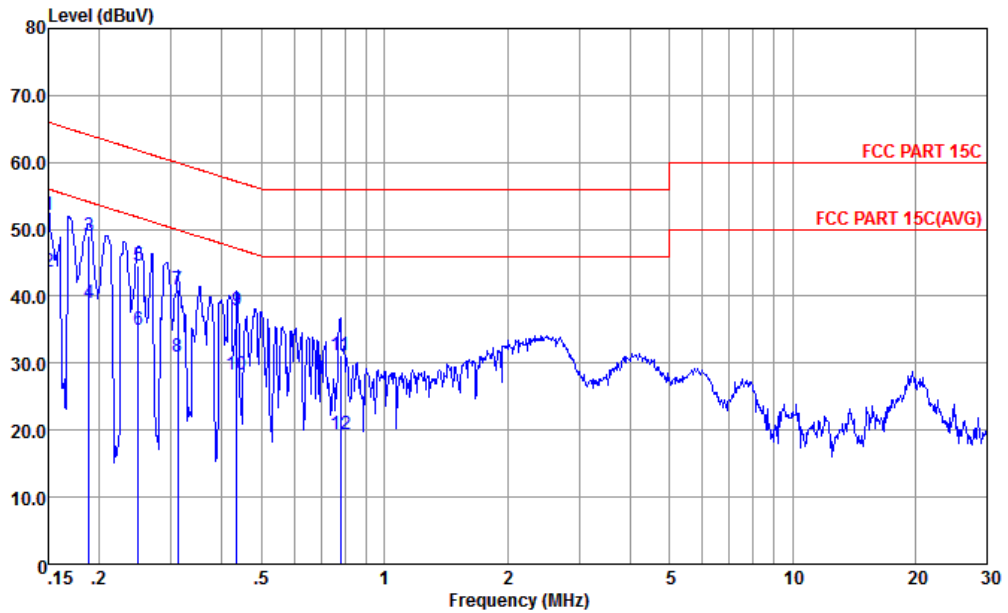

Site : CO01-KS
 Condition : FCC PART 15C LISN-N-20151024 NEUTRAL

mode : Mode 1
 IMEI : 861886030041636/861886030041644 #16

	Freq	Level	Over Limit	Limit Line	Read Level	LISN Factor	Cable Loss	Remark
	MHz	dBuV	dB	dBuV	dBuV	dB	dB	
1	0.150	52.21	-13.79	66.00	41.80	0.30	10.11	QP
2 *	0.150	43.61	-12.39	56.00	33.20	0.30	10.11	Average
3	0.188	49.13	-14.98	64.11	38.70	0.31	10.12	QP
4	0.188	39.03	-15.08	54.11	28.60	0.31	10.12	Average
5	0.249	44.65	-17.13	61.78	34.20	0.31	10.14	QP
6	0.249	35.05	-16.73	51.78	24.60	0.31	10.14	Average
7	0.312	41.06	-18.87	59.93	30.60	0.31	10.15	QP
8	0.312	30.86	-19.07	49.93	20.40	0.31	10.15	Average
9	0.435	37.89	-19.26	57.15	27.40	0.32	10.17	QP
10	0.435	28.39	-18.76	47.15	17.90	0.32	10.17	Average
11	0.779	31.10	-24.90	56.00	20.60	0.35	10.15	QP
12	0.779	19.40	-26.60	46.00	8.90	0.35	10.15	Average



3.7 Antenna Requirements

3.7.1 Standard Applicable

If directional gain of transmitting antennas is greater than 6dBi, the power shall be reduced by the same level in dB comparing to gain minus 6dBi. For the fixed point-to-point operation, the power shall be reduced by one dB for every 3 dB that the directional gain of the antenna exceeds 6 dBi. The use of a permanently attached antenna or of an antenna that uses a unique coupling to the intentional radiator shall be considered sufficient to comply with the FCC rule.

3.7.2 Antenna Anti-Replacement Construction

An embedded-in antenna design is used.

3.7.3 Antenna Gain

The antenna peak gain of EUT is less than 6 dBi. Therefore, it is not necessary to reduce maximum peak output power limit.



4 List of Measuring Equipment

Instrument	Manufacturer	Model No.	Serial No.	Characteristics	Calibration Date	Test Date	Due Date	Remark
Spectrum Analyzer	R&S	FSV40	101040	10Hz~40GHz	Aug. 09, 2016	Aug. 25, 2016~ Sep. 18, 2016	Aug. 08, 2017	Conducted (TH01-KS)
Pulse Power Sensor	Anritsu	MA2411B	0917070	300MHz~40GHz	Jan. 20, 2016	Aug. 25, 2016~ Sep. 18, 2016	Jan. 19, 2017	Conducted (TH01-KS)
Power Meter	Anritsu	ML2495A	1005002	50MHz Bandwidth	Jan. 20, 2016	Aug. 25, 2016~ Sep. 18, 2016	Jan. 19, 2017	Conducted (TH01-KS)
EMI Test Receiver	R&S	ESCI	100534	9kHz~3GHz	Oct. 24, 2015	Sep. 06, 2016	Oct. 23, 2016	Radiation (03CH03-KS)
EXA Spectrum Analyzer	Keysight	N9010A	MY55150244	10Hz~44GHz	Apr. 22, 2016	Sep. 06, 2016	Apr. 21, 2017	Radiation (03CH03-KS)
Loop Antenna	R&S	HFH2-Z2	100321	9kHz~30MHz	Nov. 07, 2015	Sep. 06, 2016	Nov. 06, 2016	Radiation (03CH03-KS)
Bilog Antenna	TeseQ	CBL6112D	35406	25MHz~2GHz	Apr. 16, 2016	Sep. 06, 2016	Apr. 15, 2017	Radiation (03CH03-KS)
Horn Antenna	Schwarzbeck	BBHA9120D	9120D-1356	1GHz~18GHz	Apr. 16, 2016	Sep. 06, 2016	Apr. 15, 2017	Radiation (03CH03-KS)
SHF-EHF Horn	Schwarzbeck	BBHA 9170	BBHA170249	15GHz~40GHz	Mar. 03, 2016	Sep. 06, 2016	Mar. 02, 2017	Radiation (03CH03-KS)
Amplifier	SONOMA	310N	187289	9kHz~1GHz	Aug. 09, 2016	Sep. 06, 2016	Aug. 08, 2017	Radiation (03CH03-KS)
high gain Amplifier	MITEQ	AMF-7D-001 01800-30-10 P	1943529	1GHz~18GHz	Jan. 20, 2016	Sep. 06, 2016	Jan. 19, 2017	Radiation (03CH03-KS)
Amplifier	Agilent	8449B	3008A02370	1GHz~26.5GHz	Oct. 24, 2015	Sep. 06, 2016	Oct. 23, 2016	Radiation (03CH03-KS)
Amplifier	MITEQ	TTA1840-35- HG	1887435	18GHz~40GHz	Jan. 20, 2016	Sep. 06, 2016	Jan. 19, 2017	Radiation (03CH03-KS)
AC Power Source	Chroma	61601	F104090004	N/A	NCR	Sep. 06, 2016	NCR	Radiation (03CH03-KS)
Turn Table	ChamPro	EM 1000-T	060762-T	0~360 degree	NCR	Sep. 06, 2016	NCR	Radiation (03CH03-KS)
Antenna Mast	ChamPro	EM 1000-A	060762-A	1 m~4 m	NCR	Sep. 06, 2016	NCR	Radiation (03CH03-KS)
EMI Receiver	R&S	ESCI7	100768	9kHz~7GHz	Apr. 29, 2016	Sep. 12, 2016	Apr. 28, 2017	Conduction (CO01-KS)
AC LISN	MessTec	AN3016	060103	9kHz~30MHz	Oct. 24, 2015	Sep. 12, 2016	Oct. 23, 2016	Conduction (CO01-KS)
AC LISN (for auxiliary equipment)	MessTec	AN3016	060105	9kHz~30MHz	Oct. 24, 2015	Sep. 12, 2016	Oct. 23, 2016	Conduction (CO01-KS)
AC Power Source	Chroma	61602	ABP000000 811	AC 0V~300V, 45Hz~1000Hz	Oct. 24, 2015	Sep. 12, 2016	Oct. 23, 2016	Conduction (CO01-KS)

NCR: No Calibration Required



5 Uncertainty of Evaluation

Uncertainty of Conducted Emission Measurement (150 kHz ~ 30 MHz)

Measuring Uncertainty for a Level of Confidence of 95% ($U = 2Uc(y)$)	2.3dB
---	-------

Uncertainty of Radiated Emission Measurement (30 MHz ~ 1GHz)

Measuring Uncertainty for a Level of Confidence of 95% ($U = 2Uc(y)$)	4.5dB
---	-------

Uncertainty of Radiated Emission Measurement (1GHz ~ 18GHz)

Measuring Uncertainty for a Level of Confidence of 95% ($U = 2Uc(y)$)	4.5dB
---	-------

Uncertainty of Radiated Emission Measurement (18GHz ~ 40GHz)

Measuring Uncertainty for a Level of Confidence of 95% ($U = 2Uc(y)$)	4.6dB
---	-------



Appendix A. Conducted Test Results

A1 - DTS Part

Test Engineer:	Silent Hai	Temperature:	24~25	°C
Test Date:	2016/08/25~2016/09/18	Relative Humidity:	50~55	%

TEST RESULTS DATA
6dB Bandwidth

2.4GHz Band							
Mod.	Data Rate	N _{TX}	CH.	Freq. (MHz)	6dB BW (MHz)	6dB BW Limit (MHz)	Pass/Fail
11b	1Mbps	1	1	2412	9.55	0.50	Pass
11b	1Mbps	1	6	2437	9.55	0.50	Pass
11b	1Mbps	1	11	2462	10.03	0.50	Pass
11g	6Mbps	1	1	2412	16.34	0.50	Pass
11g	6Mbps	1	6	2437	16.34	0.50	Pass
11g	6Mbps	1	11	2462	16.32	0.50	Pass
HT20	MCS0	1	1	2412	17.54	0.50	Pass
HT20	MCS0	1	6	2437	17.56	0.50	Pass
HT20	MCS0	1	11	2462	17.28	0.50	Pass

TEST RESULTS DATA
Peak Power Table

2.4GHz Band										
Mod.	Data Rate	NTX	CH.	Freq. (MHz)	Peak Conducted Power (dBm)	Conducted Power Limit (dBm)	DG (dBi)	EIRP Power (dBm)	EIRP Power Limit (dBm)	Pass /Fail
11b	1Mbps	1	1	2412	15.96	30.00	-4.87	11.09	36.00	Pass
11b	1Mbps	1	6	2437	14.48	30.00	-4.87	9.61	36.00	Pass
11b	1Mbps	1	11	2462	14.60	30.00	-4.87	9.73	36.00	Pass
11g	6Mbps	1	1	2412	21.77	30.00	-4.87	16.90	36.00	Pass
11g	6Mbps	1	6	2437	20.81	30.00	-4.87	15.94	36.00	Pass
11g	6Mbps	1	11	2462	20.55	30.00	-4.87	15.68	36.00	Pass
HT20	MCS0	1	1	2412	21.13	30.00	-4.87	16.26	36.00	Pass
HT20	MCS0	1	6	2437	20.09	30.00	-4.87	15.22	36.00	Pass
HT20	MCS0	1	11	2462	19.86	30.00	-4.87	14.99	36.00	Pass

TEST RESULTS DATA
Average Power Table
(Reporting Only)

2.4GHz Band						
Mod.	Data Rate	NTX	CH.	Freq. (MHz)	Duty Factor (dB)	Average Conducted Power (dBm)
11b	1Mbps	1	1	2412	0.11	13.02
11b	1Mbps	1	6	2437	0.11	11.88
11b	1Mbps	1	11	2462	0.11	11.59
11g	6Mbps	1	1	2412	0.58	12.04
11g	6Mbps	1	6	2437	0.58	10.80
11g	6Mbps	1	11	2462	0.58	10.54
HT20	MCS0	1	1	2412	0.63	11.15
HT20	MCS0	1	6	2437	0.63	9.94
HT20	MCS0	1	11	2462	0.63	9.65

TEST RESULTS DATA
Peak Power Density

2.4GHz Band								
Mod.	Data Rate	NTX	CH.	Freq. (MHz)	Peak PSD (dBm /3kHz)	DG (dBi)	Peak PSD Limit (dBm /3kHz)	Pass/Fail
11b	1Mbps	1	1	2412	-9.59	-4.87	8.00	Pass
11b	1Mbps	1	6	2437	-10.45	-4.87	8.00	Pass
11b	1Mbps	1	11	2462	-10.42	-4.87	8.00	Pass
11g	6Mbps	1	1	2412	-13.48	-4.87	8.00	Pass
11g	6Mbps	1	6	2437	-13.58	-4.87	8.00	Pass
11g	6Mbps	1	11	2462	-13.34	-4.87	8.00	Pass
HT20	MCS0	1	1	2412	-14.23	-4.87	8.00	Pass
HT20	MCS0	1	6	2437	-15.65	-4.87	8.00	Pass
HT20	MCS0	1	11	2462	-15.34	-4.87	8.00	Pass



Appendix B. Radiated Spurious Emission

2.4GHz 2400~2483.5MHz

WIFI 802.11b (Band Edge @ 3m)

WIFI	Note	Frequency	Level	Over	Limit	Read	Antenna	Cable	Preamp	Ant	Table	Peak	Pol.
				Limit	Line	Level	Factor	Loss	Factor	Pos	Pos	Avg.	
		(MHz)	(dBμV/m)	(dB)	(dBμV/m)	(dBμV)	(dB/m)	(dB)	(dB)	(cm)	(deg)	(P/A)	(H/V)
802.11b CH 01 2412MHz		2371.36	51.16	-22.84	74	55.78	26.95	5.45	37.02	100	89	P	H
		2389.69	40.93	-13.07	54	45.48	27	5.47	37.02	100	89	A	H
		2410.855	99.71	-	-	104.11	27.13	5.47	37	100	89	P	H
		2410.938	97.08	-	-	101.48	27.13	5.47	37	100	89	A	H
		2363.56	50.92	-23.08	74	55.6	26.91	5.43	37.02	381	66	P	V
		2389.82	40.66	-13.34	54	45.21	27	5.47	37.02	381	66	A	V
		2413.193	100.06	-	-	104.46	27.13	5.47	37	381	66	P	V
		2410.938	97.44	-	-	101.84	27.13	5.47	37	381	66	A	V
802.11b CH 06 2437MHz		2435.822	101.9	-	-	106.15	27.26	5.48	36.99	100	107	P	H
		2435.822	99.29	-	-	103.54	27.26	5.48	36.99	100	107	A	H
		2435.822	99.18	-	-	103.43	27.26	5.48	36.99	333	84	P	V
		2435.905	96.33	-	-	100.58	27.26	5.48	36.99	333	84	A	V
802.11b CH 11 2462MHz		2460.705	97.5	-	-	101.45	27.51	5.5	36.96	150	151	P	H
		2460.872	94.9	-	-	98.85	27.51	5.5	36.96	150	151	A	H
		2484.04	51.94	-22.06	74	55.73	27.64	5.51	36.94	150	151	P	H
		2483.68	41.11	-12.89	54	44.9	27.64	5.51	36.94	150	151	A	H
		2460.872	92.85	-	-	96.8	27.51	5.5	36.96	357	48	P	V
		2460.872	90.26	-	-	94.21	27.51	5.5	36.96	357	48	A	V
		2488.84	52.03	-21.97	74	55.67	27.77	5.52	36.93	357	48	P	V
		2483.5	40.9	-13.1	54	44.69	27.64	5.51	36.94	357	48	A	V
Remark	<p>1. No other spurious found.</p> <p>2. All results are PASS against Peak and Average limit line.</p>												



2.4GHz 2400~2483.5MHz

WIFI 802.11b (Harmonic @ 3m)

WIFI	Note	Frequency (MHz)	Level (dBμV/m)	Over Limit (dB)	Limit Line (dBμV/m)	Read Level (dBμV)	Antenna Factor (dB/m)	Cable Loss (dB)	Preamp Factor (dB)	Ant Pos (cm)	Table Pos (deg)	Peak Avg. (P/A)	Pol. (H/V)
802.11b CH 01 2412MHz		4824	43.13	-30.87	74	40.58	31.51	7.72	36.68	100	360	P	H
		4824	42.7	-31.3	74	40.15	31.51	7.72	36.68	100	360	P	V
802.11b CH 06 2437MHz		4872	43.3	-30.7	74	40.61	31.59	7.76	36.66	100	360	P	H
		7308	45.78	-28.22	74	38.68	34.03	9.76	36.69	100	360	P	H
		4872	42.33	-31.67	74	39.64	31.59	7.76	36.66	100	360	P	V
		7308	47.09	-26.91	74	39.99	34.03	9.76	36.69	100	360	P	V
802.11b CH 11 2462MHz		4926	43.17	-30.83	74	40.35	31.67	7.8	36.65	100	360	P	H
		7386	44.58	-29.42	74	37.21	34.29	9.86	36.78	100	360	P	H
		4926	42.95	-31.05	74	40.13	31.67	7.8	36.65	100	360	P	V
		7386	45.18	-28.82	74	37.81	34.29	9.86	36.78	100	360	P	V
Remark	1. No other spurious found. 2. All results are PASS against Peak and Average limit line.												



2.4GHz 2400~2483.5MHz

WIFI 802.11g (Band Edge @ 3m)

WIFI	Note	Frequency (MHz)	Level (dBμV/m)	Over Limit (dB)	Limit Line (dBμV/m)	Read Level (dBμV)	Antenna Factor (dB/m)	Cable Loss (dB)	Preamp Factor (dB)	Ant Pos (cm)	Table Pos (deg)	Peak Avg. (P/A)	Pol. (H/V)
802.11g CH 01 2412MHz		2389.69	61.17	-12.83	74	65.72	27	5.47	37.02	256	96	P	H
		2389.82	47.95	-6.05	54	52.5	27	5.47	37.02	256	96	A	H
		2406.847	101.35	-	-	105.75	27.13	5.47	37	256	96	P	H
		2405.177	93.11	-	-	97.51	27.13	5.47	37	256	96	A	H
		2388.65	61.14	-12.86	74	65.69	27	5.47	37.02	378	65	P	V
		2389.82	46.28	-7.72	54	50.83	27	5.47	37.02	378	65	A	V
		2406.429	101.25	-	-	105.65	27.13	5.47	37	378	65	P	V
		2405.094	93.06	-	-	97.46	27.13	5.47	37	378	65	A	V
802.11g CH 06 2437MHz		2432.064	100.4	-	-	104.65	27.26	5.48	36.99	283	147	P	H
		2431.98	92.15	-	-	96.4	27.26	5.48	36.99	283	147	A	H
		2432.648	101.2	-	-	105.45	27.26	5.48	36.99	100	73	P	V
		2431.396	92.4	-	-	96.65	27.26	5.48	36.99	100	73	A	V
802.11g CH 11 2462MHz		2466.8	100.92	-	-	104.87	27.51	5.5	36.96	122	114	P	H
		2455.11	91.92	-	-	95.87	27.51	5.5	36.96	122	114	A	H
		2485.66	53.24	-20.76	74	57.03	27.64	5.51	36.94	122	114	P	H
		2483.5	42.29	-11.71	54	46.08	27.64	5.51	36.94	122	114	A	H
		2456.363	98.71	-	-	102.66	27.51	5.5	36.96	375	63	P	V
		2454.943	90.71	-	-	94.66	27.51	5.5	36.96	375	63	A	V
		2483.8	52.87	-21.13	74	56.66	27.64	5.51	36.94	375	63	P	V
	2483.5	42.05	-11.95	54	45.84	27.64	5.51	36.94	375	63	A	V	
Remark	1. No other spurious found. 2. All results are PASS against Peak and Average limit line.												



2.4GHz 2400~2483.5MHz

WIFI 802.11g (Harmonic @ 3m)

WIFI	Note	Frequency (MHz)	Level (dBμV/m)	Over Limit (dB)	Limit Line (dBμV/m)	Read Level (dBμV)	Antenna Factor (dB/m)	Cable Loss (dB)	Preamp Factor (dB)	Ant Pos (cm)	Table Pos (deg)	Peak Avg. (P/A)	Pol. (H/V)
802.11g CH 01 2412MHz		4824	43.06	-30.94	74	40.51	31.51	7.72	36.68	100	360	P	H
		4824	43.75	-30.25	74	41.2	31.51	7.72	36.68	100	360	P	V
802.11g CH 06 2437MHz		4872	43.66	-30.34	74	40.97	31.59	7.76	36.66	100	360	P	H
		7311	45.1	-28.9	74	38	34.03	9.76	36.69	100	360	P	H
		4874	42.77	-31.23	74	40.08	31.59	7.76	36.66	100	0	P	V
		7308	46.32	-27.68	74	39.22	34.03	9.76	36.69	100	0	P	V
802.11g CH 11 2462MHz		4926	42.76	-31.24	74	39.94	31.67	7.8	36.65	100	360	P	H
		7386	46.38	-27.62	74	39.01	34.29	9.86	36.78	100	360	P	H
		4926	44.2	-29.8	74	41.38	31.67	7.8	36.65	100	360	P	V
		7386	46.54	-27.46	74	39.17	34.29	9.86	36.78	100	360	P	V
Remark	<ol style="list-style-type: none"> No other spurious found. All results are PASS against Peak and Average limit line. 												



2.4GHz 2400~2483.5MHz

WIFI 802.11n HT20 (Band Edge @ 3m)

WIFI	Note	Frequency (MHz)	Level (dBμV/m)	Over Limit (dB)	Limit Line (dBμV/m)	Read Level (dBμV)	Antenna Factor (dB/m)	Cable Loss (dB)	Preamp Factor (dB)	Ant Pos (cm)	Table Pos (deg)	Peak Avg. (P/A)	Pol. (H/V)
802.11n HT20 CH 01 2412MHz		2388.91	58.93	-15.07	74	63.48	27	5.47	37.02	116	2	P	H
		2389.56	44.33	-9.67	54	48.88	27	5.47	37.02	116	2	A	H
		2407.097	98.08	-	-	102.48	27.13	5.47	37	116	2	P	H
		2406.012	89.19	-	-	93.59	27.13	5.47	37	116	2	A	H
		2388.78	56.45	-17.55	74	61	27	5.47	37.02	306	62	P	V
		2389.95	43.14	-10.86	54	47.69	27	5.47	37.02	306	62	A	V
		2408.768	96.4	-	-	100.8	27.13	5.47	37	306	62	P	V
		2404.593	87.66	-	-	92.06	27.13	5.47	37	306	62	A	V
802.11n HT20 CH 06 2437MHz		2437.157	98.16	-	-	102.25	27.39	5.49	36.97	302	156	P	H
		2433.483	89.63	-	-	93.88	27.26	5.48	36.99	302	156	A	H
		2434.068	94.63	-	-	98.88	27.26	5.48	36.99	298	51	P	V
		2432.314	86.6	-	-	90.85	27.26	5.48	36.99	298	51	A	V
802.11n HT20 CH 11 2462MHz		2468.219	95.28	-	-	99.23	27.51	5.5	36.96	100	150	P	H
		2468.887	87.42	-	-	91.37	27.51	5.5	36.96	100	150	A	H
		2483.8	51.93	-22.07	74	55.72	27.64	5.51	36.94	100	150	P	H
		2483.5	41.51	-12.49	54	45.3	27.64	5.51	36.94	100	150	A	H
		2469.388	96.72	-	-	100.67	27.51	5.5	36.96	310	257	P	V
		2455.528	88.33	-	-	92.28	27.51	5.5	36.96	310	257	A	V
		2484.64	51.77	-22.23	74	55.56	27.64	5.51	36.94	310	257	P	V
		2483.5	41.46	-12.54	54	45.25	27.64	5.51	36.94	310	257	A	V
Remark	<ol style="list-style-type: none"> No other spurious found. All results are PASS against Peak and Average limit line. 												



2.4GHz 2400~2483.5MHz

WIFI 802.11n HT20 (Harmonic @ 3m)

WIFI	Note	Frequency (MHz)	Level (dBμV/m)	Over Limit (dB)	Limit Line (dBμV/m)	Read Level (dBμV)	Antenna Factor (dB/m)	Cable Loss (dB)	Preamp Factor (dB)	Ant Pos (cm)	Table Pos (deg)	Peak Avg. (P/A)	Pol. (H/V)
802.11n HT20 CH 01 2412MHz		4824	43.12	-30.88	74	40.57	31.51	7.72	36.68	100	360	P	H
		4824	42.97	-31.03	74	40.42	31.51	7.72	36.68	100	360	P	V
802.11n HT20 CH 06 2437MHz		4872	42.98	-31.02	74	40.29	31.59	7.76	36.66	100	360	P	H
		7308	45.63	-28.37	74	38.53	34.03	9.76	36.69	100	360	P	H
		4872	43.28	-30.72	74	40.59	31.59	7.76	36.66	100	360	P	V
		7308	45.56	-28.44	74	38.46	34.03	9.76	36.69	100	360	P	V
802.11n HT20 CH 11 2462MHz		4926	43.21	-30.79	74	40.39	31.67	7.8	36.65	100	360	P	H
		7386	45.6	-28.4	74	38.23	34.29	9.86	36.78	100	360	P	H
		4926	43.05	-30.95	74	40.23	31.67	7.8	36.65	100	360	P	V
		7386	46.12	-27.88	74	38.75	34.29	9.86	36.78	100	360	P	V
Remark	1. No other spurious found. 2. All results are PASS against Peak and Average limit line.												



2.4GHz 2400~2483.5MHz

Emission below 1GHz

2.4GHz WIFI 802.11n HT20 (LF)

WIFI	Note	Frequency	Level	Over	Limit	Read	Antenna	Cable	Preamp	Ant	Table	Peak	Pol.
		(MHz)	(dBμV/m)	(dB)	Limit Line	(dBμV)	(dB/m)	(dB)	(dB)	Pos	Pos	Avg.	
					(dBμV/m)					(cm)	(deg)	(P/A)	(H/V)
2.4GHz 802.11n HT20 LF		30.97	26.57	-13.43	40	30.34	26.86	0.66	31.29	100	32	P	H
		65.89	21.72	-18.28	40	38.85	13.38	0.98	31.49	-	-	P	H
		89.17	28.62	-14.88	43.5	41.55	17.4	1.14	31.47	-	-	P	H
		210.42	26.21	-17.29	43.5	39.88	16.08	1.73	31.48	-	-	P	H
		317.12	28.68	-17.32	46	38	19.81	2.19	31.32	-	-	P	H
		450.98	29.21	-16.79	46	32.35	25.46	2.64	31.24	-	-	P	H
		30.97	31.07	-8.93	40	34.84	26.86	0.66	31.29	100	200	P	V
		57.16	24.47	-15.53	40	40.84	14.14	0.9	31.41	-	-	P	V
		89.17	32.75	-10.75	43.5	45.68	17.4	1.14	31.47	-	-	P	V
		156.1	23.21	-20.29	43.5	35.59	17.65	1.51	31.54	-	-	P	V
		323.91	27.01	-18.99	46	35.97	20.13	2.21	31.3	-	-	P	V
		454.86	28.69	-17.31	46	31.99	25.28	2.66	31.24	-	-	P	V
Remark	1. No other spurious found. 2. All results are PASS against limit line.												



Note symbol

	Fundamental Frequency which can be ignored. However, the level of any unwanted emissions shall not exceed the level of the fundamental frequency.
!	Test result is over limit line.
P/A	Peak or Average
H/V	Horizontal or Vertical



A calculation example for radiated spurious emission is shown as below:

WIFI	Note	Frequency	Level	Over	Limit	Read	Antenna	Cable	Preamp	Ant	Table	Peak	Pol.
Ant.				Limit	Line	Level	Factor	Loss	Factor	Pos	Pos	Avg.	
1		(MHz)	(dBμV/m)	(dB)	(dBμV/m)	(dBμV)	(dB/m)	(dB)	(dB)	(cm)	(deg)	(P/A)	(H/V)
802.11b		2390	55.45	-18.55	74	54.51	32.22	4.58	35.86	103	308	P	H
CH 01		2390	43.54	-10.46	54	42.6	32.22	4.58	35.86	103	308	A	H
2412MHz													

- Level(dBμV/m) =
Antenna Factor(dB/m) + Cable Loss(dB) + Read Level(dBμV) - Preamp Factor(dB)
- Over Limit(dB) = Level(dBμV/m) – Limit Line(dBμV/m)

For Peak Limit @ 2390MHz:

- Level(dBμV/m)
= Antenna Factor(dB/m) + Cable Loss(dB) + Read Level(dBμV) - Preamp Factor(dB)
= 32.22(dB/m) + 4.58(dB) + 54.51(dBμV) – 35.86 (dB)
= 55.45 (dBμV/m)
- Over Limit(dB)
= Level(dBμV/m) – Limit Line(dBμV/m)
= 55.45(dBμV/m) – 74(dBμV/m)
= -18.55(dB)

For Average Limit @ 2390MHz:

- Level(dBμV/m)
= Antenna Factor(dB/m) + Cable Loss(dB) + Read Level(dBμV) - Preamp Factor(dB)
= 32.22(dB/m) + 4.58(dB) + 42.6(dBμV) – 35.86 (dB)
= 43.54 (dBμV/m)
- Over Limit(dB)
= Level(dBμV/m) – Limit Line(dBμV/m)
= 43.54(dBμV/m) – 54(dBμV/m)
= -10.46(dB)

Both peak and average measured complies with the limit line, so test result is “PASS”.



Appendix C. Duty Cycle Plots

Band	Duty Cycle(%)	T(ms)	1/T(kHz)	VBW Setting
802.11b	97.59	8.23	0.12	300Hz
802.11g	87.50	1.37	0.73	1kHz
2.4GHz 802.11n HT20	86.53	1.28	0.78	1kHz

802.11b

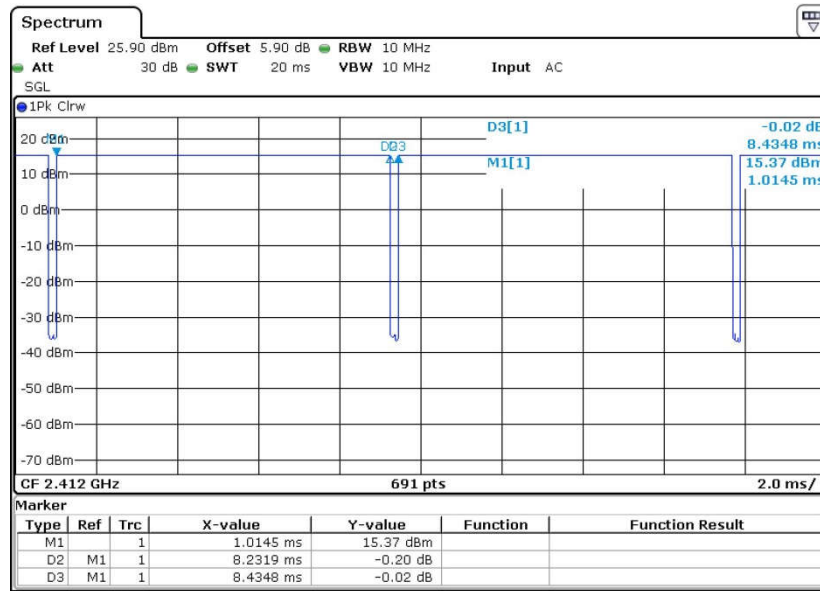



802.11g

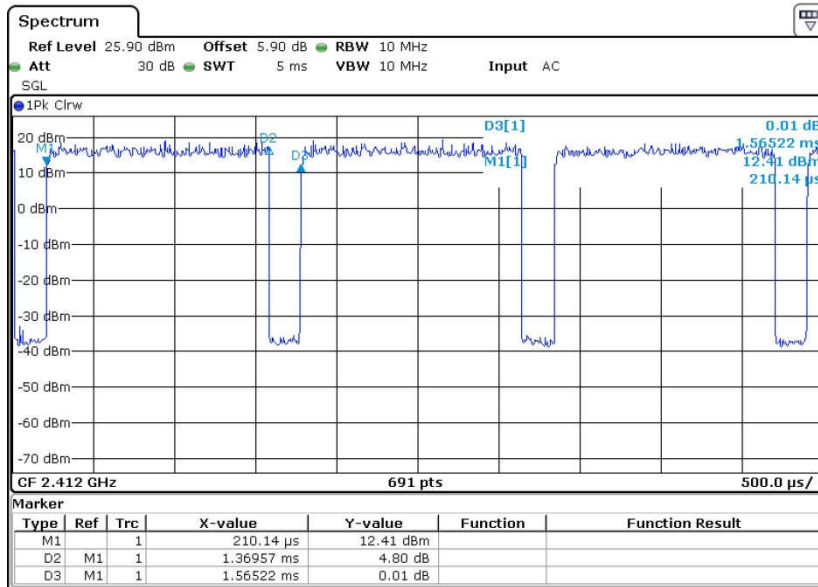

2.4GHz 802.11n HT20

