



Test Report No.: RF131126N045-1



FCC TEST REPORT (PART 22)

REPORT NO.: RF131126N045-1
MODEL NO.: Lenovo A859
MID: 85900031
FCC ID: YCNA859
RECEIVED: Nov. 26, 2013
TESTED: Nov. 26, 2013 ~ Dec. 03, 2013
ISSUED: Dec. 03, 2013

APPLICANT: Lenovo Mobile Communication Technology Ltd.

ADDRESS: No.999, Qishan North 2nd Road, Information & Optoelectronics Park, Torch Hi-tech Industry Development Zone, Xiamen, P.R.China

ISSUED BY: Bureau Veritas Shenzhen Co., Ltd.
Dongguan Branch

LAB ADDRESS: No. 34, Chenwulu Section, Guantai Road, Houjie Town, Dongguan City, Guangdong 523942, China

TEST LOCATION: No. 34, Chenwulu Section, Guantai Road, Houjie Town, Dongguan City, Guangdong 523942, China

This report should not be used by the client to claim product certification, approval, or endorsement by A2LA or any government agencies.

This report is for your exclusive use. Any copying or replication of this report to or for any other person or entity, or use of our name or trademark, is permitted only with our prior written permission. This report sets forth our findings solely with respect to the test samples identified herein. The results set forth in this report are not indicative or representative of the quality or characteristics of the lot from which a test sample was taken or any similar or identical product unless specifically and expressly noted. Our report includes all of the tests requested by you and the results thereof based upon the information that you provided to us. You have 60 days from date of issuance of this report to notify us of any material error or omission caused by our negligence, provided, however, that such notice shall be in writing and shall specifically address the issue you wish to raise. A failure to raise such issue within the prescribed time shall constitute your unqualified acceptance of the completeness of this report, the tests conducted and the correctness of the report contents. Unless specific mention, the uncertainty of measurement has been explicitly taken into account to declare the compliance or non-compliance to the specification.

Bureau Veritas Shenzhen Co., Ltd.
Dongguan Branch

No. 34, Chenwulu Section, Guantai Rd.,
Houjie Town, Dongguan City,
Guangdong 523942, China

Tel: +86 769 8593 5656
Fax: +86 769 8593 1080
Email: customerservice.dg@cn.bureauveritas.com



BUREAU
VERITAS

Test Report No.: RF131126N045-1

TABLE OF CONTENTS

RELEASE CONTROL RECORD..... 4

1 CERTIFICATION 5

2 SUMMARY OF TEST RESULTS 6

 2.1 MEASUREMENT UNCERTAINTY 6

3 GENERAL INFORMATION..... 8

 3.1 GENERAL DESCRIPTION OF EUT..... 8

 3.2 CONFIGURATION OF SYSTEM UNDER TEST 10

 3.3 DESCRIPTION OF SUPPORT UNITS..... 10

 3.4 TEST ITEM AND TEST CONFIGURATION 11

 3.5 EUT OPERATING CONDITIONS..... 12

 3.6 GENERAL DESCRIPTION OF APPLIED STANDARDS..... 12

4 TEST TYPES AND RESULTS 13

 4.1 OUTPUT POWER MEASUREMENT 13

 4.1.1 LIMITS OF OUTPUT POWER MEASUREMENT 13

 4.1.2 TEST PROCEDURES 13

 4.1.3 TEST SETUP 14

 4.1.4 TEST RESULTS..... 15

 4.2 FREQUENCY STABILITY MEASUREMENT 17

 4.2.1 LIMITS OF FREQUENCY STABILITY MEASUREMENT 17

 4.2.2 TEST PROCEDURE 17

 4.2.3 TEST SETUP 17

 4.2.4 TEST RESULTS..... 18

 4.3 OCCUPIED BANDWIDTH MEASUREMENT 19

 4.3.1 TEST PROCEDURES 19

 4.3.2 EST SETUP 19

 4.3.3 TEST RESULTS..... 20

 4.4 BAND EDGE MEASUREMENT 22

 4.4.1 LIMITS OF BAND EDGE MEASUREMENT 22

 4.4.2 TEST SETUP 22

 4.4.3 TEST PROCEDURES 22

 4.4.4 TEST RESULTS..... 23

 4.5 CONDUCTED SPURIOUS EMISSIONS..... 24

 4.5.1 LIMITS OF CONDUCTED SPURIOUS EMISSIONS MEASUREMENT 24

 4.5.2 TEST PROCEDURE 24

 4.5.3 TEST SETUP 24

 4.5.4 TEST RESULTS..... 25

 4.6 RADIATED EMISSION MEASUREMENT 28

 4.6.1 LIMITS OF RADIATED EMISSION MEASUREMENT 28

 4.6.2 TEST PROCEDURES 28

 4.6.3 DEVIATION FROM TEST STANDARD 28

 4.6.4 TEST SETUP 29

 4.6.5 TEST RESULTS..... 30

5. PHOTOGRAPHS OF THE TEST CONFIGURATION 33



**BUREAU
VERITAS**

Test Report No.: RF131126N045-1

6. INFORMATION ON THE TESTING LABORATORIES	34
7. APPENDIX A – MODIFICATIONS RECORDERS FOR ENGINEERING CHANGES TO THE EUT BY THE LAB	35



**BUREAU
VERITAS**

Test Report No.: RF131126N045-1

RELEASE CONTROL RECORD

ISSUE NO.	REASON FOR CHANGE	DATE ISSUED
RF131126N045-1	Original release	Dec. 03, 2013



BUREAU
VERITAS

Test Report No.: RF131126N045-1

1 CERTIFICATION

PRODUCT: Lenovo Mobile Phone

MODEL: Lenovo A859

BRAND: lenovo

APPLICANT: Lenovo Mobile Communication Technology Ltd.

TESTED: Nov. 26, 2013 ~ Dec. 03, 2013

TEST SAMPLE: Production Unit

STANDARDS: FCC PART 22, Subpart H

The above equipment (model: Lenovo A859) has been tested by **Bureau Veritas Shenzhen Co., Ltd. Dongguan Branch**, and found compliance with the requirement of the above standards. The test record, data evaluation & Equipment Under Test (EUT) configurations represented herein are true and accurate accounts of the measurements of the sample's EMC characteristics under the conditions specified in this report.

TESTED BY

:

Glyn He/ Project Engineer

DATE :

Dec. 03, 2013

APPROVED BY

:

Sam Tung / Technical Manager

DATE :

Dec. 03, 2013



2 SUMMARY OF TEST RESULTS

The EUT has been tested according to the following specifications:

APPLIED STANDARD: FCC Part 22 & Part 2			
STANDARD SECTION	TEST TYPE	RESULT	REMARK
2.1046 22.913 (a)	Effective Radiated Power	PASS	Meet the requirement of limit.
2.1055 22.355	Frequency Stability	PASS	Meet the requirement of limit.
2.1049	Occupied Bandwidth	PASS	Meet the requirement of limit.
22.917	Band Edge Measurements	PASS	Meet the requirement of limit.
2.1051 22.917	Conducted Spurious Emissions	PASS	Meet the requirement of limit.
2.1053 22.917	Radiated Spurious Emissions	PASS	Meet the requirement of limit.

2.1 MEASUREMENT UNCERTAINTY

Where relevant, the following measurement uncertainty levels have been estimated for tests performed on the EUT as specified in CISPR 16-4-2:

MEASUREMENT	FREQUENCY	UNCERTAINTY
Conducted emissions	9kHz~30MHz	2.67dB
Radiated emissions	30MHz ~ 1GHz	4.81dB
	1GHz ~ 18GHz	4.3dB
	18GHz ~ 40GHz	1.94dB

This uncertainty represents an expanded uncertainty expressed at approximately the 95% confidence level using a coverage factor of k=2.



2.2 TEST SITE AND INSTRUMENTS

Equipment	Manufacturer	Model No.	Serial No.	Last Cal.	Next Cal.
Spectrum Analyzer	Agilent	E4446A	MY46180622	Apr. 24,13	Apr. 23,14
EMI Test Receiver	Rohde&Schwarz	ESVD	847398/003	May 14,13	May 13,14
Bilog Antenna (25MHz-2GHz)	Teseq	CBL 6111D	27089	Jul. 27, 13	Jul. 26, 14
Horn Antenna (1GHz -18GHz)	EMCO	3117	00062558	Oct.18, 12	Oct.17,14
Pre-Amplifier (20MHz-3GHz)	EMCI	EMC 330	980095	Nov. 02,13	Nov. 01,14
Pre-Amplifier (100MHz-26.5GHz)	Agilent	8449B	3008A00409	May 14,13	May 13,14
10m Semi-anechoic Chamber	CHANGLING	21.4m*12.1m*8.8m	NSEMC006	Mar. 24,13	Mar. 23,14
Digital Multimeter	FLUKE	15B	A1220010D G	Oct. 31,13	Oct. 30,14
Horn Antenna (15GHz-40GHz)	SCHWARZBECK	BBHA 9170	BBHA91702 42	Jan. 04,12	Jan. 03,14
Pre-Amplifier (18GHz-40GHz)	EMCI	EMC 184045	980102	Nov. 04,13	Nov. 03,14
Power Meter	Anritsu	ML2495A	1139001	Nov. 04,13	Nov. 03,14
Humid & Temp Programmable Tester	Haida	HD-2257	110807201	Sep. 17,13	Sep. 16,14
Universal Radio Communication Tester	Rohde&Schwarz	CMU 200	123259	Apr. 16,12	Apr. 15,14
Test Software	ADT	ADT_Radiated_V7.6.15	N/A	N/A	N/A

- NOTE:**
1. The calibration interval of the above test instruments is 12 months or 24 months and the calibrations are traceable to CEPREI/CHINA, GRGT/CHINA and NIM/CHINA.
 2. The test was performed in Dongguan 10m Chamber
 3. The horn antenna are used only for the measurement of emission frequency above 1GHz if tested.
 4. The FCC Site Registration No. is 502831.



3 GENERAL INFORMATION

3.1 GENERAL DESCRIPTION OF EUT

PRODUCT	Lenovo Mobile Phone
MODEL NO.	Lenovo A859
MID	85900031
FCC ID	YCNA859
HW Version	A859.ROW.V3
SW Version	A859_ROW_S106
POWER SUPPLY	5.0Vdc (adapter or host equipment) 3.7Vdc (Li-ion battery)
MODULATION TYPE	GSM, GPRS: GMSK EDGE: 8PSK WCDMA : BPSK
FREQUENCY RANGE	GSM, GPRS, EDGE: 824.2MHz ~ 848.8MHz WCDMA: 826.4MHz ~ 846.6MHz
MAX. ERP POWER	GSM: 1.63Watts EDGE: 0.56Watts WCDMA: 0.34Watts
POWER CLASS	3
ANTENNA TYPE	Fixed Internal antenna with -1.59dBi gain
I/O PORTS	Refer to user's manual
CABLE SUPPLIED	USB cable 1: Shielded, Detachable, 1.0m Earphone cable: Unshielded, Detachable, 1.0m
ACCESSORY DEVICES	Refer to note as below

NOTE:

1. WLAN, GSM, WCDMA technologies are used for the EUT.
2. The EUT's accessories list refers to EUT Photo. pdf. The EUT was powered by the following adapter:

ADAPTER	
BRAND:	Lenovo
MODEL:	C-P56
INPUT:	AC 100-240V, 50/60Hz,150mA
OUTPUT:	DC 5V, 1000mA
DC LINE:	N/A



**BUREAU
VERITAS**

Test Report No.: RF131126N045-1

3. The above EUT information was declared by manufacturer and for more detailed features description, please refer to the manufacturer's specifications or user's manual.



3.2 CONFIGURATION OF SYSTEM UNDER TEST FOR RADIATION EMISSION TEST

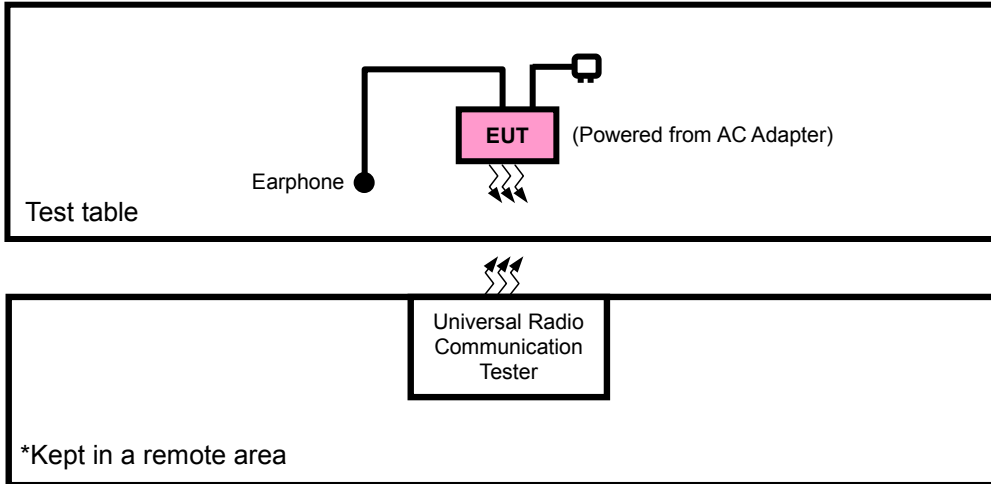

3.3 DESCRIPTION OF SUPPORT UNITS

The EUT has been tested as an independent unit together with other necessary accessories or support units. The following support units or accessories were used to form a representative test configuration during the tests.

NO.	PRODUCT	BRAND	MODEL NO.	SERIAL NO.	FCC ID
1	Notebook	DELL	5P2PM2X	12400120329	N/A
2	Mouse	DELL	M056UOA	01688082	N/A

NO.	SIGNAL CABLE DESCRIPTION OF THE ABOVE SUPPORT UNITS
1.	AC Line :Unshielded, Detachable,1.5m;DC Line: Unshielded, Undetachable,1.8m; HDMI Cable: Shielded, Detachable,1.6m, with a core
2	USB Line: Unshielded, undetachable, 1.5m.



3.4 TEST ITEM AND TEST CONFIGURATION

Pre-Scan has been conducted to determine the worst-case mode from all possible combinations between available modulations, data rates, XYZ axis and antenna ports. The worst case was found when positioned on Z-plane for ERP and X-axis for radiated emission. Following channel(s) was (were) selected for the final test as listed below:

EUT CONFIGURE MODE	DESCRIPTION
A	EUT + Adapter + Earphone with GSM link
B	EUT + Battery + Earphone with GSM link

GSM MODE

EUT CONFIGURE MODE	TEST ITEM	AVAILABLE CHANNEL	TESTED CHANNEL	MODE
B	ERP	128 to 251	128, 189, 251	GSM, EDGE
B	FREQUENCY STABILITY	128 to 251	189	GSM, EDGE
B	OCCUPIED BANDWIDTH	128 to 251	128, 189, 251	GSM, EDGE
B	BAND EDGE	128 to 251	128, 251	GSM, EDGE
A	CONDCUDED EMISSION	128 to 251	128, 189, 251	GSM, EDGE
A	RADIATED EMISSION	128 to 251	189	GSM, EDGE

WCDMA MODE

EUT CONFIGURE MODE	TEST ITEM	AVAILABLE CHANNEL	TESTED CHANNEL	MODE
B	ERP	4132 to 4233	4132, 4182, 4233	WCDMA
B	FREQUENCY STABILITY	4132 to 4233	4182	WCDMA
B	OCCUPIED BANDWIDTH	4132 to 4233	4132, 4182, 4233	WCDMA, HSDPA, HSUPA
B	BAND EDGE	4132 to 4233	4132, 4233	WCDMA, HSDPA, HSUPA
A	CONDCUDED EMISSION	4132 to 4233	4132, 4182, 4233	WCDMA
A	RADIATED EMISSION	4132 to 4233	4182	WCDMA



**BUREAU
VERITAS**

Test Report No.: RF131126N045-1

TEST CONDITION:

TEST ITEM	ENVIRONMENTAL CONDITIONS	INPUT POWER	TESTED BY
ERP	23deg. C, 59%RH	3.7Vdc from Battery	Venless Long
FREQUENCY STABILITY	23deg. C, 59%RH	3.7Vdc from Battery	Venless Long
OCCUPIED BANDWIDTH	23deg. C, 59%RH	3.7Vdc from Battery	Venless Long
BAND EDGE	23deg. C, 59%RH	3.7Vdc from Battery	Venless Long
CONDCUDED EMISSION	24deg. C, 56%RH	5Vdc from adapter	Endy Xie
RADIATED EMISSION	25deg. C, 57%RH	5Vdc from adapter	Blue

3.5 EUT OPERATING CONDITIONS

The EUT makes a call to the communication simulator. The communication simulator station system controlled a EUT to export maximum output power under transmission mode and specific channel frequency

3.6 GENERAL DESCRIPTION OF APPLIED STANDARDS

The EUT is a RF product. According to the specifications of the manufacturer, it must comply with the requirements of the following standards:

FCC 47 CFR Part 2

FCC 47 CFR Part 22

ANSI/TIA/EIA-603-C 2004

- NOTE:**
1. All test items have been performed and recorded as per the above standards.
 2. The EUT is also considered as a kind of computer peripheral, because the connection to computer is necessary for typical use. It has been verified to comply with the requirements of FCC Part 15, Subpart B, Class B (DoC) . The test report has been issued separately.



BUREAU
VERITAS

Test Report No.: RF131126N045-1

4 TEST TYPES AND RESULTS

4.1 OUTPUT POWER MEASUREMENT

4.1.1 LIMITS OF OUTPUT POWER MEASUREMENT

Mobile / Portable station are limited to 7 watts e.r.p.

4.1.2 TEST PROCEDURES

EIRP / ERP MEASUREMENT:

- a. All measurements were done at low, middle and high operational frequency range. RBW and VBW is 1MHz for GSM, GPRS & EDGE and 5MHz for WCDMA mode.
- b. Substitution method is used for E.I.R.P measurement. In the semi-anechoic chamber, EUT placed on the 0.8m height of Turn Table, rotated the table around 360 degrees to search the maximum radiation power and receiver antenna shall be rotated vertical and horizontal polarization and moved height from 1m to 4m to find the maximum polar radiated power. The “Read Value” is the spectrum reading the maximum power value.
- c. The substitution horn antenna is substituted for EUT at the same position and signals generator export the CW signal to the substitution antenna via a tx cable. Rotated the Turn Table and moved receiving antenna to find the maximum radiation power. Adjust output power level of S.G to get a Value of spectrum reading equal to “Read Value “ of step b. Record the power level of S.G
- d. $EIRP = \text{Output power level of S.G} - \text{TX cable loss} + \text{Antenna gain of substitution horn.}$ E.R.P power can be calculated form E.I.R.P power by subtracting the gain of dipole, $E.R.P \text{ power} = E.I.R.P \text{ power} - 2.15\text{dBi}$.

CONDUCTED POWER MEASUREMENT:

The EUT was set up for the maximum power with GSM, GPRS, EDGE & WCDMA link data modulation and link up with simulator. Set the EUT to transmit under low, middle and high channel and record the power level shown on simulator.



BUREAU VERITAS

Test Report No.: RF131126N045-1

4.1.3 TEST SETUP

EIRP / ERP MEASUREMENT:

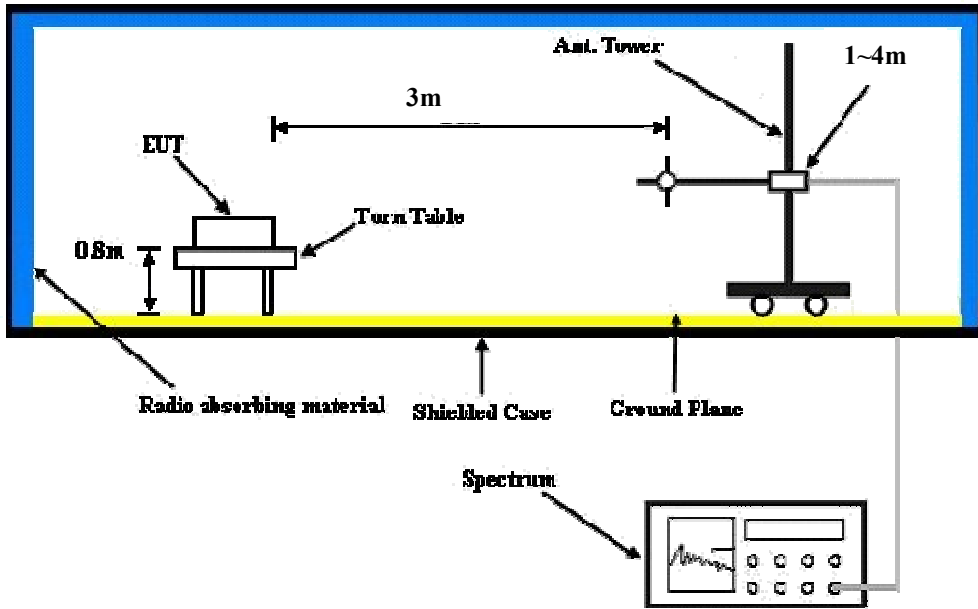

For the actual test configuration, please refer to the attached file (Test Setup Photo).

CONDUCTED POWER MEASUREMENT:

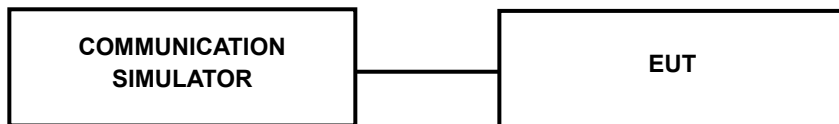

For the actual test configuration, please refer to the attached file (Test Setup Photo).



**BUREAU
VERITAS**

Test Report No.: RF131126N045-1

4.1.4 TEST RESULTS

CONDUCTED OUTPUT POWER (dBm)

Band	GSM850		
Channel	128	189	251
Frequency (MHz)	824.2	836.4	848.8
GSM	32.18	32.14	32.21
GPRS 8	32.17	32.13	32.19
GPRS 10	31.45	31.43	31.49
GPRS 11	29.98	29.96	30.06
GPRS 12	29.25	29.21	29.32
EDGE 8 (MCS1)	32.17	32.12	32.20
EDGE 10 (MCS1)	31.45	31.41	31.50
EDGE 11 (MCS1)	29.98	29.95	30.05
EDGE 12 (MCS1)	29.24	29.21	29.31
EDGE 8 (MCS9)	26.88	26.90	26.65
EDGE 10 (MCS9)	25.86	25.88	25.62
EDGE 11 (MCS9)	23.87	23.90	23.61
EDGE 12 (MCS9)	22.81	22.85	22.50

Band	WCDMA V		
Channel	4132	4182	4233
Frequency (MHz)	826.4	836.4	846.6
RMC 12.2K	22.61	22.47	22.60
HSDPA Subtest-1	21.63	21.51	21.64
HSDPA Subtest-2	21.63	21.49	21.66
HSDPA Subtest-3	21.21	21.07	21.18
HSDPA Subtest-4	21.18	21.03	21.18
HSUPA Subtest-1	21.66	21.51	21.64
HSUPA Subtest-2	19.65	19.51	19.63
HSUPA Subtest-3	20.64	20.50	20.62
HSUPA Subtest-4	20.17	20.01	20.14
HSUPA Subtest-5	21.62	21.46	21.59



BUREAU
VERITAS

Test Report No.: RF131126N045-1

ERP POWER (dBm)

GSM 850 (Horizontal)					
CHANNEL NO.	FREQUENCY (MHz)	SPA Reading (dBm)	CORRECTION FACTOR (dB)	ERP POWER	
				dBm	Watt
128	824.2	-0.75	32.91	30.01	1.00
189	836.4	-0.33	33.7	31.22	1.32
251	848.8	0.14	34.14	32.13	1.63
GSM 850 (Vertical)					
CHANNEL NO.	FREQUENCY (MHz)	SPA Reading (dBm)	CORRECTION FACTOR (dB)	ERP POWER	
				dBm	Watt
128	824.2	-3.46	35.18	29.57	0.91
189	836.4	-4.10	35.27	29.02	0.80
251	848.8	-4.62	35.27	28.50	0.71

EDGE 850 (1 Uplink) (Horizontal)					
CHANNEL NO.	FREQUENCY (MHz)	SPA Reading (dBm)	CORRECTION FACTOR (dB)	ERP POWER	
				dBm	Watt
128	824.2	-5.65	32.91	25.11	0.32
189	836.4	-5.13	33.7	26.42	0.44
251	848.8	-4.54	34.14	27.45	0.56
EDGE 850 (1 Uplink) (Vertical)					
CHANNEL NO.	FREQUENCY (MHz)	SPA Reading (dBm)	CORRECTION FACTOR (dB)	ERP POWER	
				dBm	Watt
128	824.2	-8.46	35.18	24.57	0.29
189	836.4	-9.10	35.27	24.02	0.25
251	848.8	-9.62	35.27	23.50	0.22

WCDMA Band V_RMC 12.2K (Horizontal)					
CHANNEL NO.	FREQUENCY (MHz)	SPA Reading (dBm)	CORRECTION FACTOR (dB)	ERP POWER	
				dBm	Watt
4132	826.4	-7.86	33.11	23.10	0.20
4182	836.4	-7.25	33.7	24.30	0.27
4233	846.6	-6.64	34.13	25.34	0.34
WCDMA Band V_RMC 12.2K (Vertical)					
CHANNEL NO.	FREQUENCY (MHz)	SPA Reading (dBm)	CORRECTION FACTOR (dB)	ERP POWER	
				dBm	Watt
4132	826.4	-12.06	35.28	21.07	0.13
4182	836.4	-11.24	35.27	21.88	0.15
4233	846.6	-10.87	35.37	22.35	0.17

REMARKS: 1. ERP Output Power (dBm) = SPA Reading (dBm) + Correction Factor (dB) -2.15 (dB)

2. Correction factor (dB) = Free Space Loss + Antenna Factor + Cable Loss.



4.2 FREQUENCY STABILITY MEASUREMENT

4.2.1 LIMITS OF FREQUENCY STABILITY MEASUREMENT

1.5 ppm is for base and fixed station. 2.5 ppm is for mobile station.

4.2.2 TEST PROCEDURE

- a. Device is placed at the oven room. The oven room could control the temperatures and humidity. Power warm up is at least 15 min and power applied should perform before recording frequency error.
- b. EUT is connected the external power supply to control the DC input power. The test voltage range is from minimum to maximum working voltage. Each step shall be record the frequency error rate.
- c. The temperature range step is 10 degrees in this test items. All temperature levels shall be hold the $\pm 0.5^{\circ}\text{C}$ during the measurement testing. The each temperature step shall be at least 0.5 hours, consider the EUT could be test under the stability condition.

NOTE: The frequency error was recorded frequency error from the communication simulator.

4.2.3 TEST SETUP

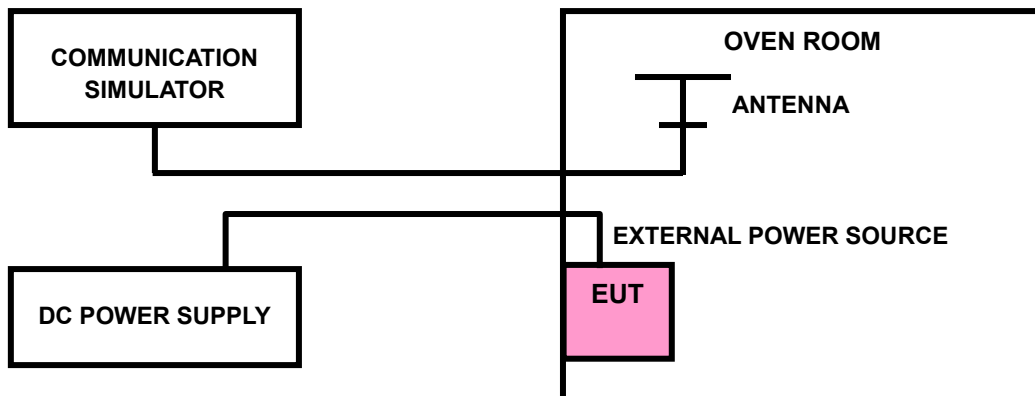



4.2.4 TEST RESULTS

FREQUENCY ERROR VS. VOLTAGE

VOLTAGE (Volts)	FREQUENCY ERROR (ppm)			LIMIT (ppm)
	GSM	EDGE	WCDMA	
4.2	0.0172	0.0169	0.0158	2.5
3.7	0.0128	0.0130	0.0122	2.5
3.6	0.0150	0.0152	0.0136	2.5

NOTE: The applicant defined the normal working voltage of the battery is from 3.6Vdc to 4.2Vdc.

FREQUENCY ERROR vs. TEMPERATURE.

TEMP. (°C)	FREQUENCY ERROR (PPM)			LIMIT (PPM)
	GSM	EDGE	WCDMA	
-10	-0.0100	-0.0085	-0.0075	2.5
0	-0.0030	-0.0030	-0.0043	2.5
10	0.0050	0.0042	0.0029	2.5
20	0.0077	0.0069	0.0062	2.5
30	0.0100	0.0090	0.0093	2.5
40	0.0120	0.0123	0.0111	2.5
45	0.0149	0.0140	0.0135	2.5



4.3 OCCUPIED BANDWIDTH MEASUREMENT

4.3.1 TEST PROCEDURES

The EUT makes a call to the communication simulator. All measurements were done at low, middle and high operational frequency range. The communication simulator station system controlled a EUT to export maximum output power under transmission mode and specific channel frequency. Use OBW measurement function of Spectrum analyzer to measure 99 % occupied bandwidth.

4.3.2 EST SETUP

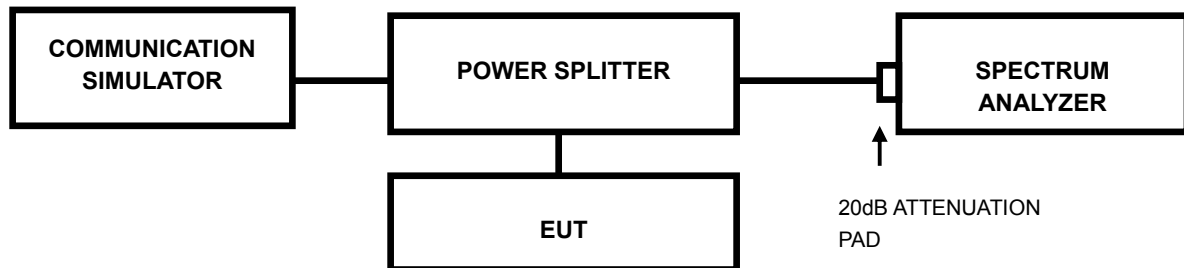



4.3.3 TEST RESULTS

CHANNEL	FREQUENCY (MHz)	99% OCCUPIED BANDWIDTH (kHz)		CHANNEL	FREQUENCY (MHz)	99% OCCUPIED BANDWIDTH (kHz)
		GSM	EDGE			WCDMA
128	824.2	247.83	244.93	4132	826.4	4140
190	836.6	244.93	244.93	4182	836.4	4160
251	848.8	244.93	246.38	4233	846.6	4160

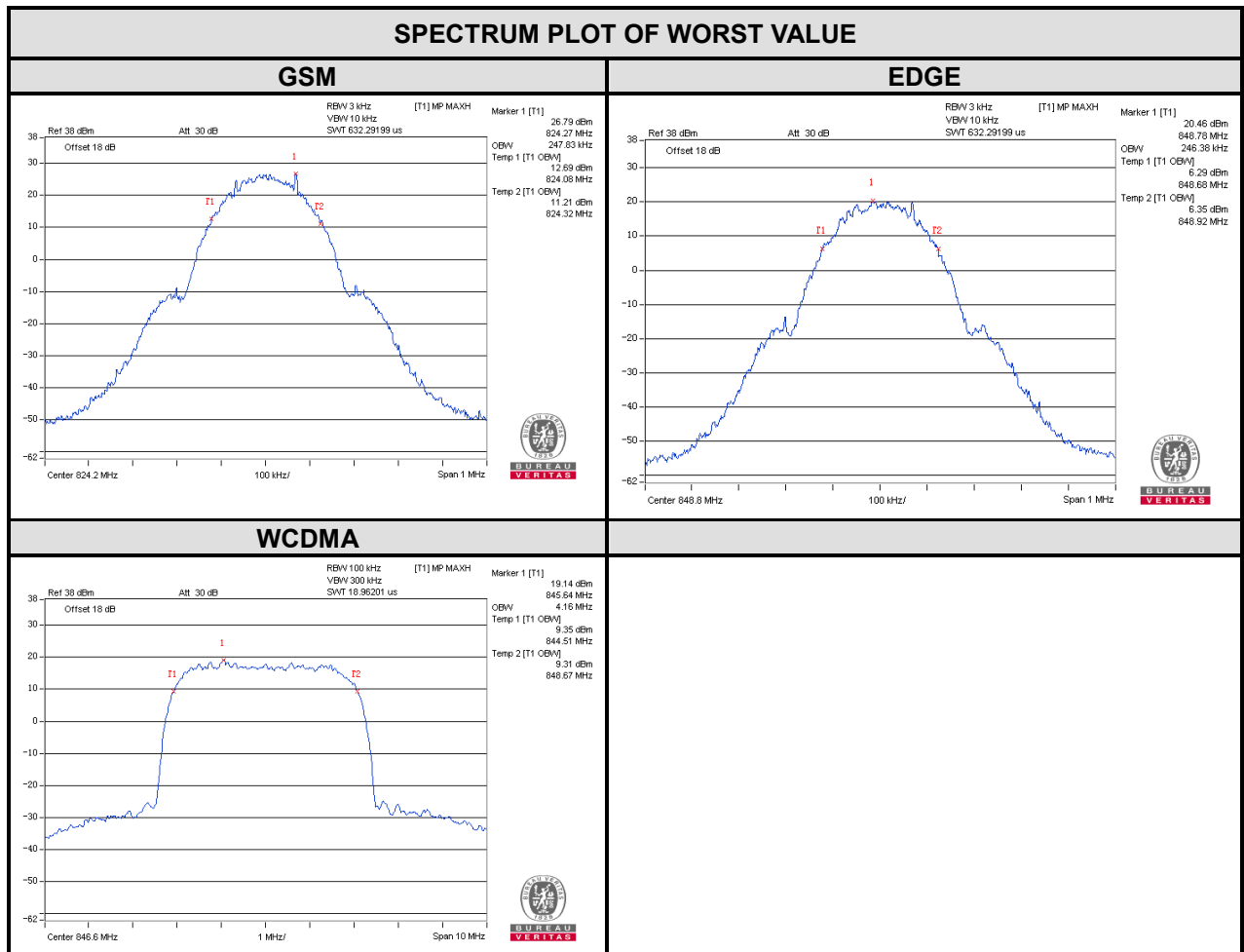



**BUREAU
VERITAS**

Test Report No.: RF131126N045-1

CHANNEL	FREQUENCY (MHz)	26dB BANDWIDTH (kHz)		CHANNEL	FREQUENCY (MHz)	26dB BANDWIDTH (kHz)
		GSM	EDGE			WCDMA
128	824.2	315.8	312.7	4132	826.4	4687
190	836.6	316.5	318.8	4182	836.4	4705
251	848.8	318.9	315.3	4233	846.6	4699

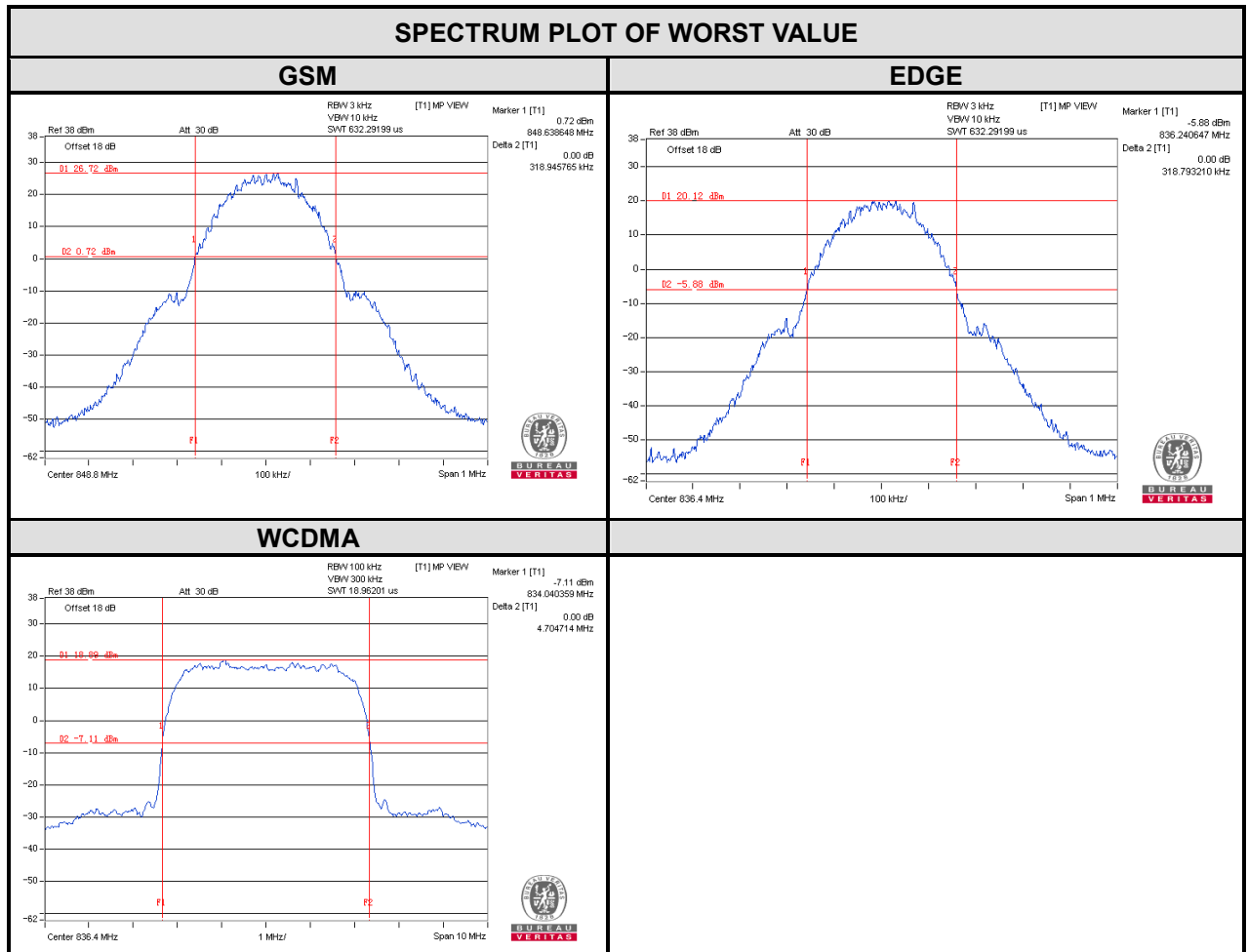



4.4 BAND EDGE MEASUREMENT

4.4.1 LIMITS OF BAND EDGE MEASUREMENT

Power of any emission outside of the authorized operating frequency ranges must be attenuated below the transmitting power (P) by a factor of at least $43 + 10 \log(P)$ dB. In the 1 MHz bands immediately outside and adjacent to the frequency block a resolution bandwidth of at least one percent of the emission bandwidth of the fundamental emission of the transmitter may be employed.

4.4.2 TEST SETUP

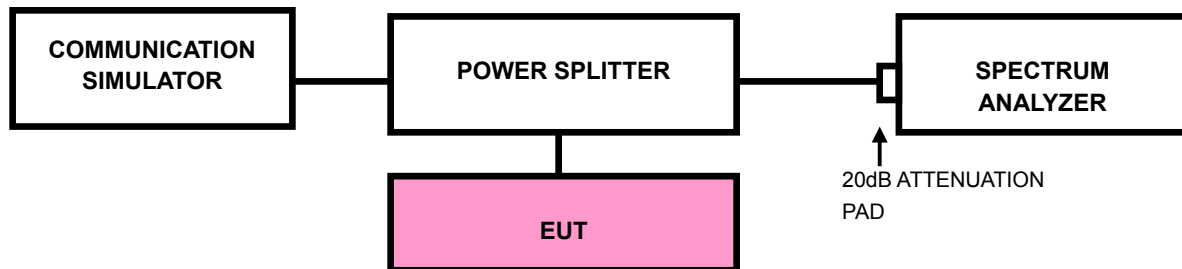

4.4.3 TEST PROCEDURES

- a. All measurements were done at low and high operational frequency range.
- b. The center frequency of spectrum is the band edge frequency and span is 1.5 MHz. RB of the spectrum is 3kHz and VB of the spectrum is 10kHz (GSM/GPRS/EDGE).
- c. The center frequency of spectrum is the band edge frequency and span is 10MHz. RB of the spectrum is 100kHz and VB of the spectrum is 300kHz (WCDMA).
- d. Record the max trace plot into the test report.



4.4.4 TEST RESULTS

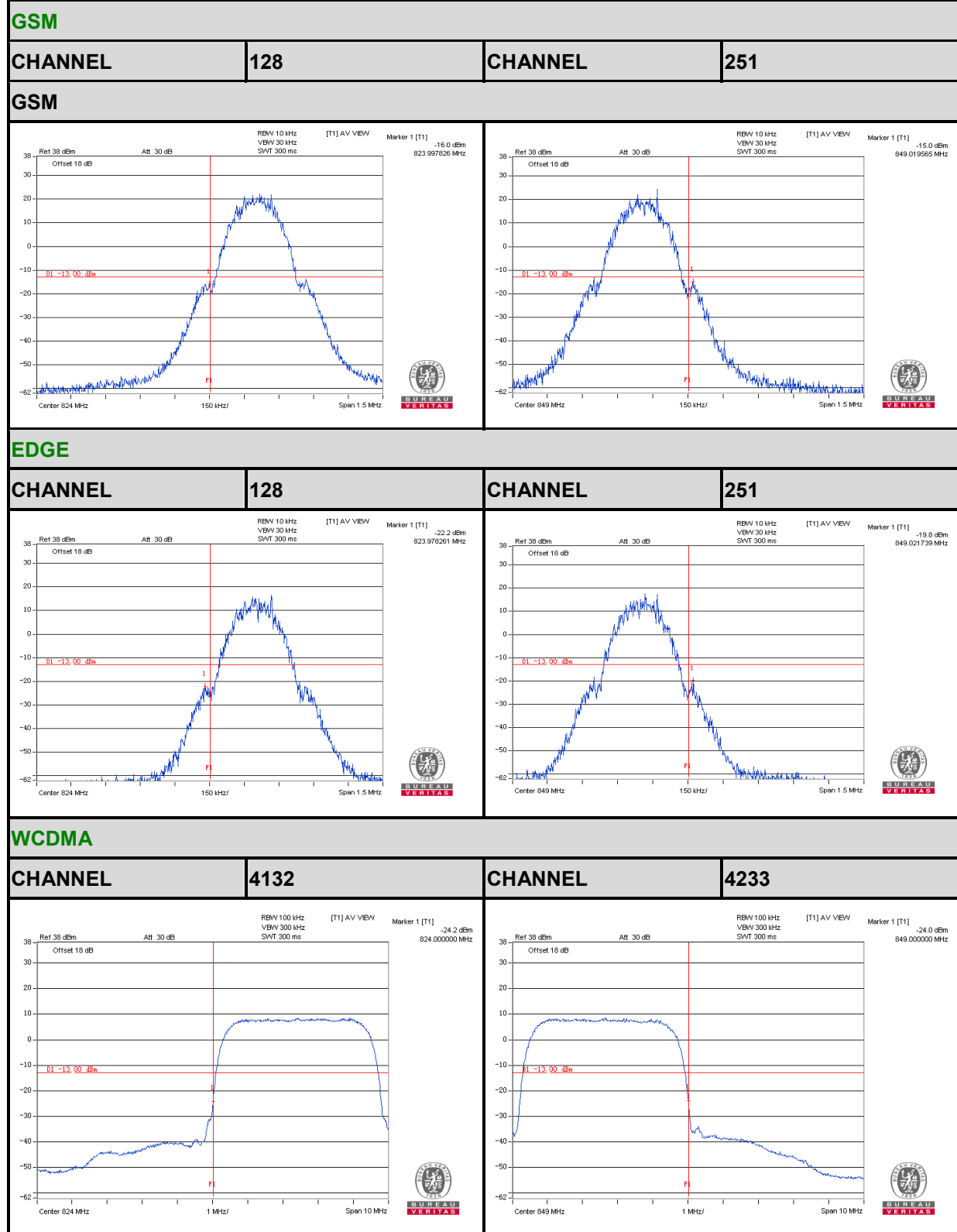



4.5 CONDUCTED SPURIOUS EMISSIONS

4.5.1 LIMITS OF CONDUCTED SPURIOUS EMISSIONS MEASUREMENT

The power of any emission outside of the authorized operating frequency ranges must be attenuated below the transmitting power (P) by a factor of at least $43 + 10 \log(P)$ dB. The emission limit equal to -13dBm .

4.5.2 TEST PROCEDURE

- a. The EUT makes a phone call to the communication simulator. All measurements were done at low, middle and high operational frequency range.
- b. Measuring frequency range is from 9 kHz to 9GHz. 20dB attenuation pad is connected with spectrum. RBW=1MHz and VBW=3MHz is used for conducted emission measurement.

4.5.3 TEST SETUP

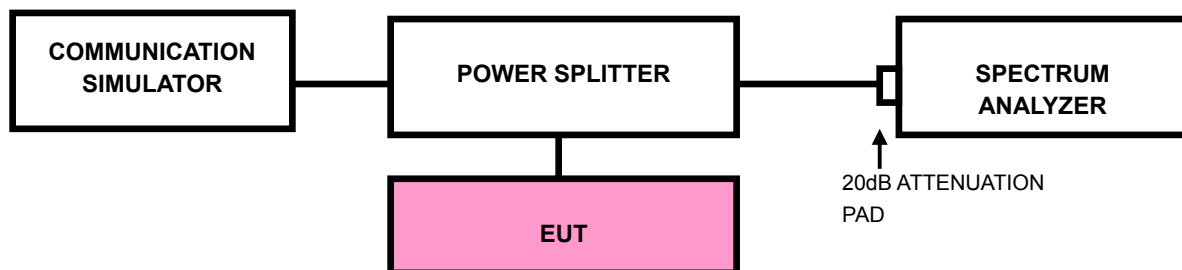



4.5.4 TEST RESULTS

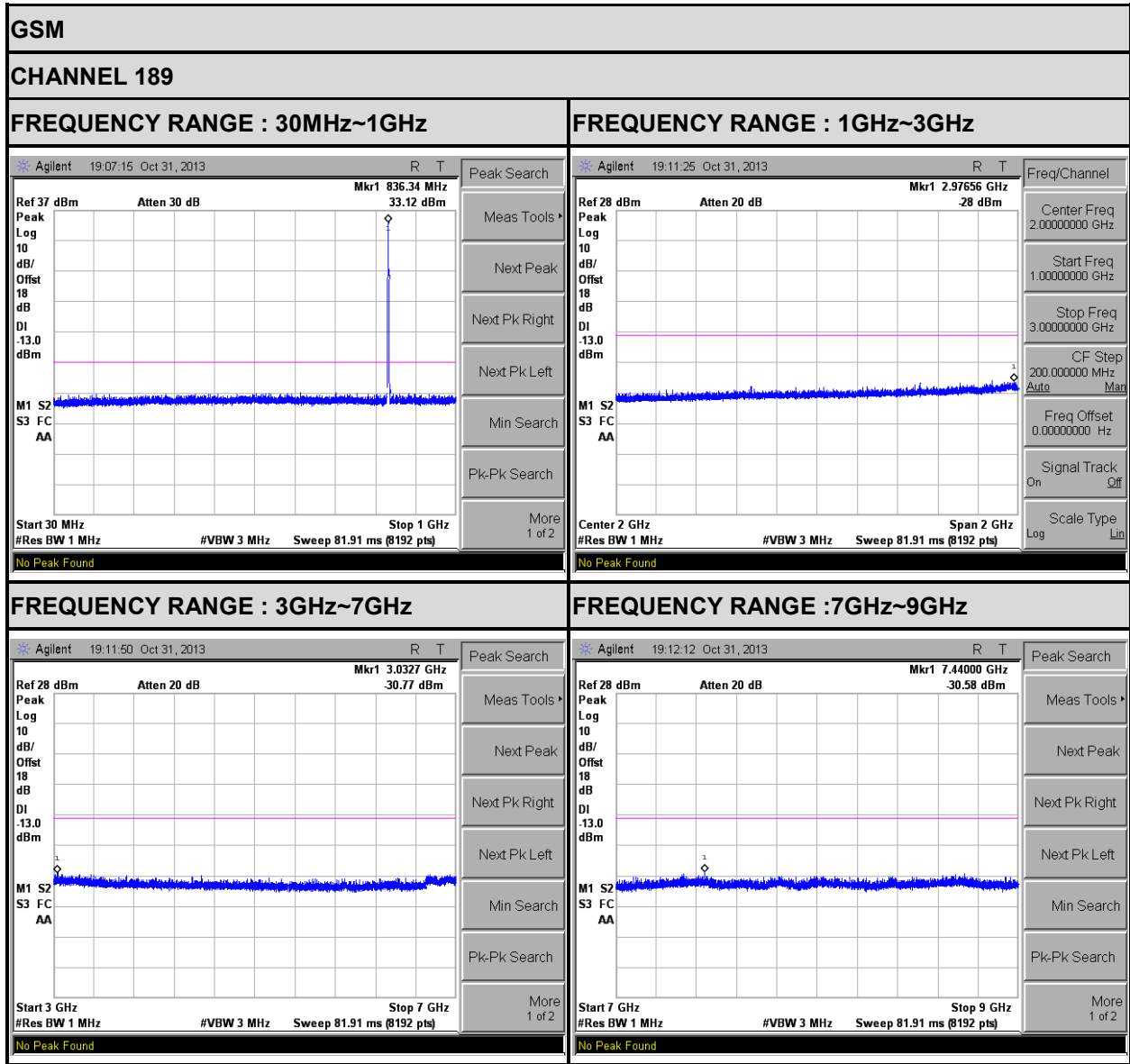



BUREAU VERITAS

Test Report No.: RF131126N045-1

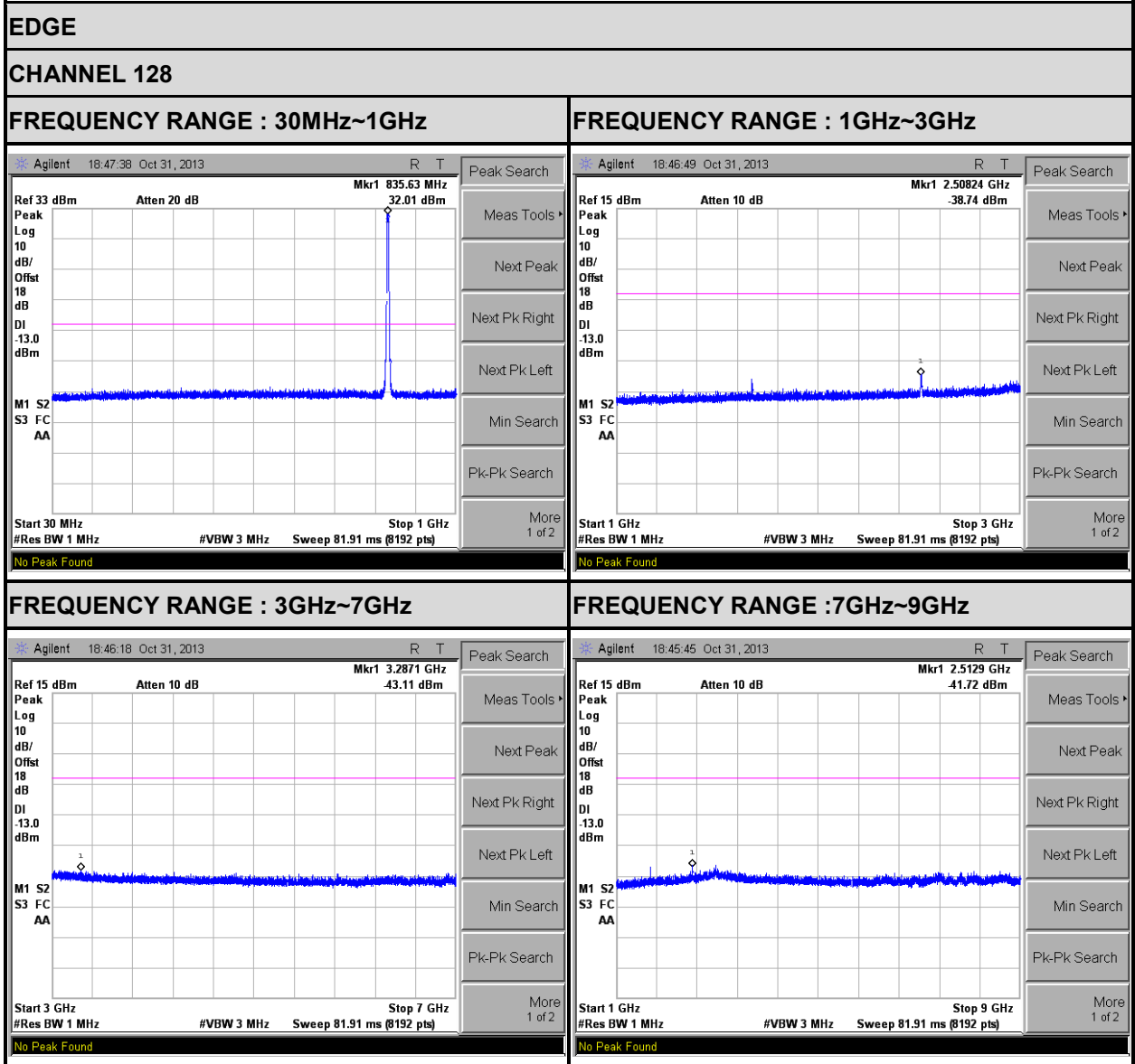



BUREAU VERITAS

Test Report No.: RF131126N045-1

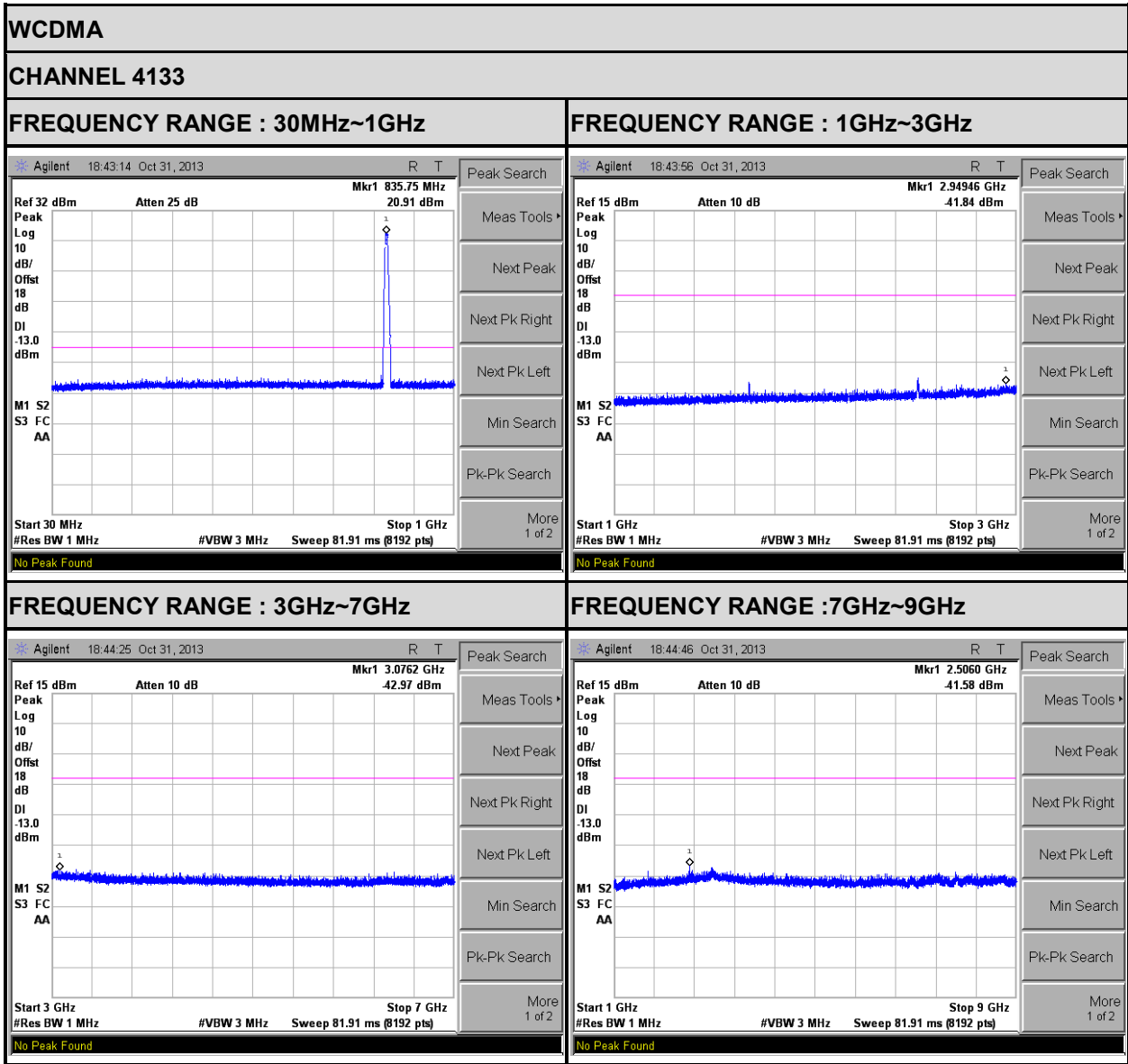



BUREAU
VERITAS

Test Report No.: RF131126N045-1

4.6 RADIATED EMISSION MEASUREMENT

4.6.1 LIMITS OF RADIATED EMISSION MEASUREMENT

The power of any emission outside of the authorized operating frequency ranges must be attenuated below the transmitting power (P) by a factor of at least $43 + 10 \log(P)$ dB. The emission limit equal to -13dBm .

4.6.2 TEST PROCEDURES

- a. Substitution method is used for E.I.R.P measurement. In the semi-anechoic chamber, EUT placed on the 0.8m height of Turn Table, rotated the table around 360 degrees to search the maximum radiation power and receiver antenna shall be rotated vertical and horizontal polarization and moved height from 1m to 4m to find the maximum polar radiated power. The “Read Value” is the spectrum reading the maximum power value.
- b. The substitution horn antenna is substituted for EUT at the same position and signals generator export the CW signal to the substitution antenna via a TX cable. Rotated the Turn Table and moved receiving antenna to find the maximum radiation power. Adjust output power level of S.G to get a Value of spectrum reading equal to “Read Value” of step a. Record the power level of S.G
- c. $\text{EIRP} = \text{Output power level of S.G} - \text{TX cable loss} + \text{Antenna gain of substitution horn}$.
- d. E.R.P power can be calculated form E.I.R.P power by subtracting the gain of dipole, $\text{E.R.P power} = \text{E.I.P.R power} - 2.15\text{dBi}$.

NOTE: The resolution bandwidth and video bandwidth of test receiver/spectrum analyzer is 1MHz/3MHz.

4.6.3 DEVIATION FROM TEST STANDARD

No deviation



BUREAU
VERITAS

Test Report No.: RF131126N045-1

4.6.4 TEST SETUP

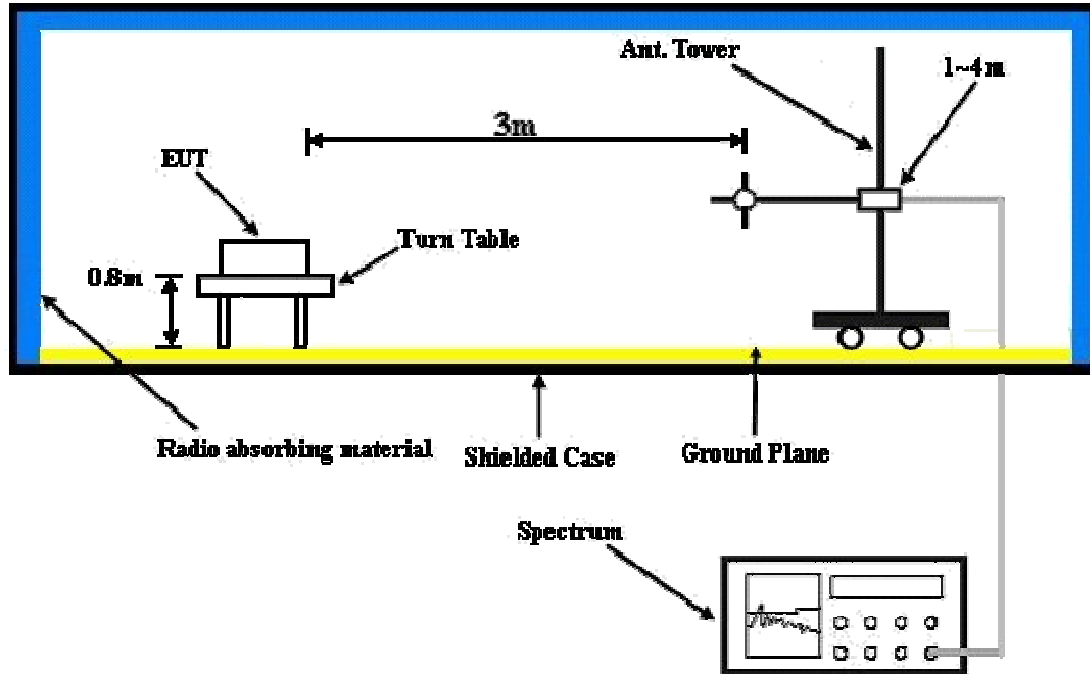

For the actual test configuration, please refer to the attached file (Test Setup Photo).



BUREAU
VERITAS

Test Report No.: RF131126N045-1

4.6.5 TEST RESULTS

GSM:

ANTENNA POLARITY & TEST DISTANCE: HORIZONTAL AT 3 M						
No.	Freq. (MHz)	SPA READING (dBm)	Limit (dBm)	S.G Power Value (dBm)	Correction Factor (dB)	ERP (dBm)
1	1672	-51.37	-13	-46.67	0.46	-46.21
2	2509	-47.07	-13	-38.24	0.17	-38.07
3	3345	-58.86	-13	-49.49	1.49	-48.00
ANTENNA POLARITY & TEST DISTANCE: VERTICAL AT 3 M						
No.	Freq. (MHz)	SPA READING (dBm)	Limit (dBm)	S.G Power Value (dBm)	Correction Factor (dB)	ERP (dBm)
1	1672	-47.78	-13	-40.34	0.46	-39.88
2	2509	-59.51	-13	-49.76	0.17	-49.59
3	3345	-66.04	-13	-54.27	1.49	-52.78

REMARKS:

1. ERP (dBm) = S.G Value (dBm) + Correction Factor (dB).
2. Correction Factor (dB) = Substitution Antenna Gain (dB) + Cable Loss (dB) - 2.15 (dB)



BUREAU
VERITAS

Test Report No.: RF131126N045-1

EDGE:

ANTENNA POLARITY & TEST DISTANCE: HORIZONTAL AT 3 M						
No.	Freq. (MHz)	Emission Level (dBuV)	Limit (dBm)	S.G Power Value (dBm)	Correction Factor (dB)	ERP (dBm)
1	1672	-51.07	-13	-46.37	0.46	-45.91
2	2509	-62.86	-13	-54.67	0.17	-54.50
3	3345	-66.77	-13	-57.59	1.49	-56.10
ANTENNA POLARITY & TEST DISTANCE: VERTICAL AT 3 M						
No.	Freq. (MHz)	Emission Level (dBuV)	Limit (dBm)	S.G Power Value (dBm)	Correction Factor (dB)	ERP (dBm)
1	1672	-49.26	-13	-41.88	0.46	-41.42
2	2509	-57.71	-13	-47.90	0.17	-47.73
3	3345	-66.3	-13	-54.53	1.49	-53.04

REMARKS:

1. ERP (dBm) = S.G Value (dBm) + Correction Factor (dB).
2. Correction Factor (dB) = Substitution Antenna Gain (dB) + Cable Loss (dB) - 2.15 (dB)



BUREAU
VERITAS

Test Report No.: RF131126N045-1

WCDMA:

ANTENNA POLARITY & TEST DISTANCE: HORIZONTAL AT 3 M						
No.	Freq. (MHz)	SPA READING (dBm)	Limit (dBm)	S.G Power Value (dBm)	Correction Factor (dB)	ERP (dBm)
1	1672	-54.27	-13	-49.65	0.46	-49.19
2	2509	-46.12	-13	-37.25	0.17	-37.08
3	3345	-55.96	-13	-46.52	1.49	-45.03
ANTENNA POLARITY & TEST DISTANCE: VERTICAL AT 3 M						
No.	Freq. (MHz)	SPA READING (dBm)	Limit (dBm)	S.G Power Value (dBm)	Correction Factor (dB)	ERP (dBm)
1	1672	-49.68	-13	-42.32	0.46	-41.86
2	2509	-57.41	-13	-47.59	0.17	-47.42
3	3345	-67.24	-13	-55.47	1.49	-53.98

REMARKS:

1. ERP (dBm) = S.G Value (dBm) + Correction Factor (dB).
2. Correction Factor (dB) = Substitution Antenna Gain (dB) + Cable Loss (dB) - 2.15 (dB)



**BUREAU
VERITAS**

Test Report No.: RF131126N045-1

5. PHOTOGRAPHS OF THE TEST CONFIGURATION

Please refer to the attached file (Test Setup Photo).



**BUREAU
VERITAS**

Test Report No.: RF131126N045-1

6 INFORMATION ON THE TESTING LABORATORIES

We, Bureau Veritas Shenzhen Co., Ltd. Dongguan Branch, were founded in 2002 to provide our best service in EMC, Radio, Telecom and Safety consultation. Our laboratories are accredited and approved according to ISO/IEC 17025.

If you have any comments, please feel free to contact us at the following:

Dongguan EMC/RF Lab:

Tel: +86-769-85935656

Fax: +86-769-85931080

Email: customerservice.dg@cn.bureauveritas.com

Web Site: www.adt.com.tw

The address and road map of all our labs can be found in our web site also.



**BUREAU
VERITAS**

Test Report No.: RF131126N045-1

7 APPENDIX A – MODIFICATIONS RECORDERS FOR ENGINEERING CHANGES TO THE EUT BY THE LAB

No any modifications are made to the EUT by the lab during the test.

---END---