



# FCC RF Test Report

**APPLICANT** : Lenovo Mobile Communication Technology Ltd.  
**EQUIPMENT** : Lenovo Mobile Phone  
**BRAND NAME** : Lenovo  
**MODEL NAME** : Lenovo A7010a48  
**FCC ID** : YCNA7010A48  
**STANDARD** : FCC Part 15 Subpart C §15.225  
**CLASSIFICATION** : (DXX) Low Power Communication Device Transmitter

The product was received on Nov. 23, 2015 and testing was completed on Dec. 08, 2015. We, SPORTON INTERNATIONAL (KUNSHAN) INC., would like to declare that the tested sample has been evaluated in accordance with the test procedures and has been in compliance with the applicable technical standards.

The test results in this report apply exclusively to the tested model / sample. Without written approval of SPORTON INTERNATIONAL (KUNSHAN) INC., the test report shall not be reproduced except in full.

---

Prepared by: James Huang / Manager



---

Approved by: Jones Tsai / Manager

**SPORTON INTERNATIONAL (KUNSHAN) INC.**  
**No. 3-2, PingXiang Road, Kunshan, Jiangsu Province, P. R. China**



## Table of Contents

**REVISION HISTORY** ..... 3

**SUMMARY OF THE TEST RESULT** ..... 4

**1. GENERAL INFORMATION** ..... 5

    1.1 Applicant ..... 5

    1.2 Manufacturer ..... 5

    1.3 Product Details ..... 5

    1.4 Component List ..... 5

    1.5 Modification of EUT ..... 6

    1.6 Testing Location ..... 6

    1.7 Applicable Standards ..... 6

    1.8 Test Modes ..... 6

    1.9 Test Configurations ..... 7

    1.10 Table for Supporting Units ..... 7

**2. CONDUCTED EMISSION TEST** ..... 8

    2.1 Measuring Instruments ..... 8

    2.2 Test setup ..... 8

    2.3 Test Result of Conducted Emission Test ..... 8

    2.4 AC Power Line Conducted Emissions Measurement ..... 9

**3. CONDUCTED TEST ITEMS** ..... 10

    3.1 Measuring Instruments ..... 10

    3.2 Test Setup ..... 10

    3.3 Test Result of Conducted Test Items ..... 10

    3.4 20dB and 99% OBW Spectrum Bandwidth Measurement ..... 11

    3.5 Frequency Stability Measurement ..... 11

**4. RADIATED TEST ITEMS** ..... 12

    4.1 Measuring Instruments ..... 12

    4.2 Test Setup ..... 12

    4.3 Test Result of Radiated Test Items ..... 12

    4.4 Field Strength of Fundamental Emissions and Mask Measurement ..... 13

    4.5 Radiated Emissions Measurement ..... 14

**5. LIST OF MEASURING EQUIPMENT** ..... 16

**APPENDIX A. TEST RESULTS OF CONDUCTED EMISSION TEST**

**APPENDIX B. TEST RESULTS OF CONDUCTED TEST ITEMS**

    B.1. Test Result of 20dB Spectrum Bandwidth

    B.2 Test Result of Frequency Stability

**APPENDIX C. TEST RESULTS OF RADIATED TEST ITEMS**

    C.1 Test Result of Field Strength of Fundamental Emissions

    C.2 Results of Radiated Emissions (9 kHz~30MHz)

    C.3 Results of Radiated Emissions (30MHz~1GHz)

**APPENDIX D. SETUP PHOTOGRAPHS OF EUT**



### REVISION HISTORY

REPORT NO.	VERSION	DESCRIPTION	ISSUED DATE
FR5N2306D	Rev. 01	Initial issue of report	Dec. 11, 2015



**SUMMARY OF THE TEST RESULT**

Applied Standard: 47 CFR FCC Part 15 Subpart C				
Part	FCC Rule	Description of Test	Result	Under Limit
3.1	15.207	AC Power Line Conducted Emissions	Complies	7.89 dB at 13.560MHz
3.2	15.225(a)(b)(c)	Field Strength of Fundamental Emissions	Complies	73.22 dB at 13.560 MHz
3.3	2.1049	20dB Spectrum Bandwidth	Complies	-
3.3	-	99% OBW Spectrum Bandwidth	Complies	-
3.4	15.225(d) 15.209	Radiated Emissions	Complies	8.47 dB at 33.880 MHz
3.5	15.225(e)	Frequency Stability	Complies	-
3.6	15.203	Antenna Requirements	Complies	-

Test Items	Uncertainty	Remark
AC Power Line Conducted Emissions	±2.3 dB	Confidence levels of 95%
Radiated Emissions (30MHz~1000MHz)	±4.5 dB	Confidence levels of 95%



## 1. GENERAL INFORMATION

### 1.1 Applicant

**Lenovo Mobile Communication Technology Ltd.**

No.999, Qishan North 2nd Road, Information & Optoelectronics Park, Torch Hi-tech Industry Development Zone, Xiamen, P.R.China

### 1.2 Manufacturer

**Lenovo PC HK Limited**

23/F, Lincoln House, Taikoo Place 979 King's Road, Quarry Bay, Hong Kong

### 1.3 Product Details

Items	Description
<b>Tx/Rx Frequency Range</b>	13.553 ~ 13.567MHz
<b>Channel Number</b>	1
<b>20dBW</b>	2.49 KHz
<b>99%OBW</b>	2.11 KHz
<b>Antenna Type</b>	FPC Antenna
<b>Type of Modulation</b>	ASK

**Remark:** The above EUT's information was declared by manufacturer. Please refer to the specifications or user's manual for more detailed description.

### 1.4 Component List

**Note:** There are two types of EUT, the details refer the following table.

Component	Sample 1	Sample 2
Front camera	QTECH F5693AQ	O-film L5693F20
Back Camera	O-film L3M2A00	SUNNY F13S05P
LCD Panel	Tianma TL055VDXP47-00	BOE BS055FHM-A00-6904
Battery	Lenovo(SCUD) BL256	Lenovo(Veken) BL256
Memory	Samsung KM4Z0013M-B809	Hynix H9TQ26ABJTMCUR-KUM



### 1.5 Modification of EUT

No modifications are made to the EUT during all test items.

### 1.6 Testing Location

<b>Test Site</b>	SPORTON INTERNATIONAL (KUNSHAN) INC.			
<b>Test Site Location</b>	No. 3-2, PingXiang Road, Kunshan, Jiangsu Province, P. R. China TEL: +86-0512-5790-0158 FAX: +86-0512-5790-0958			
<b>Test Site No.</b>	<b>Sporton Site No.</b>			<b>FCC Registration No.</b>
	TH01-KS	CO01-KS	03CH03-KS	
<b>Test Engineer</b>	Issac Song	Amos zhang	Leve Zhao	306251
<b>Temperature</b>	24~25°C	22~24°C	22~23°C	
<b>Relative Humidity</b>	49~51%	44~46%	41~42%	

**Note:** The test site complies with ANSI C63.4 2014 requirement.

### 1.7 Applicable Standards

According to the specifications of the manufacturer, the EUT must comply with the requirements of the following standards:

- ♦ FCC Part 15 Subpart C §15.225
- ♦ ANSI C63.10-2013

### 1.8 Test Modes

Investigation has been done on all the possible configurations for searching the worst cases. The following table is a list of the test modes shown in this test report.

Test Items	
AC Power Line Conducted Emissions	Field Strength of Fundamental Emissions
20dB Spectrum Bandwidth	Frequency Stability
Radiated Emissions 9kHz~30MHz	Radiated Emissions 30MHz~1GHz
<b>Note:</b>	
1. The EUT was programmed to be in continuously transmitting mode.	
2. The ancillary equipment, NFC card, is used to make the EUT (NFC) continuously transmit at 13.56MHz and is placed around 3 cm gap to the EUT.	

## 1.9 Test Configurations

### <AC Conducted Emissions>

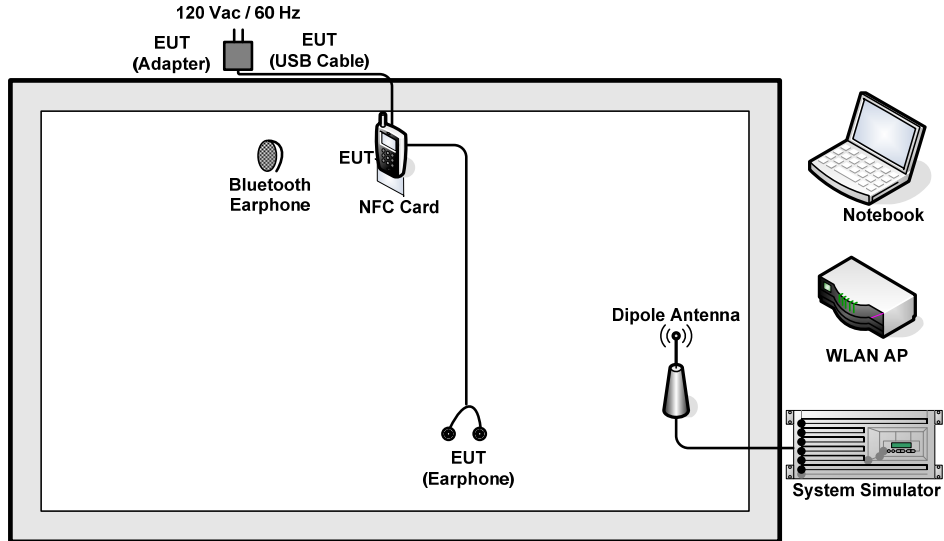

### < For Fundamental Emissions and Mask and Radiated Emissions Measurement >

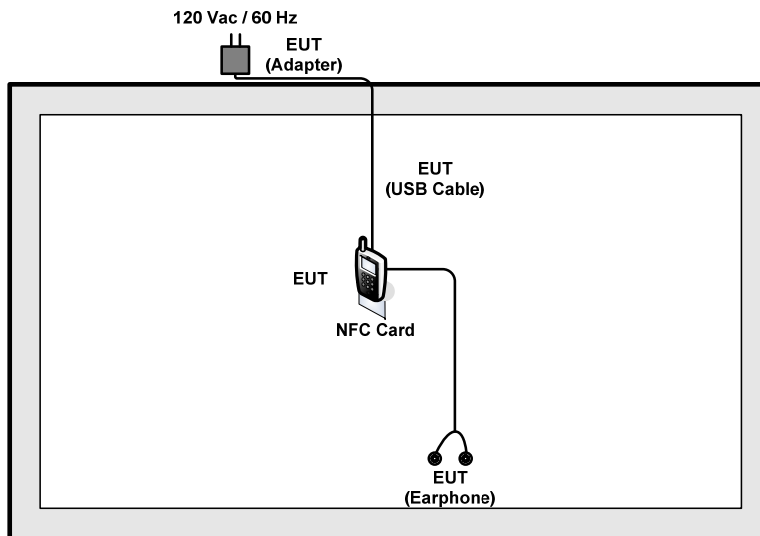

## 1.10 Table for Supporting Units

Support Unit	Manufacturer	Model	FCC ID
NFC Card	N/A	N/A	N/A
WLAN AP	LINKSYS	WRT600N	Q87-WRT600NV11
System Simulator	R&S	CMU 200	N/A
Notebook	Lenovo	G480	N/A
Bluetooth Earphone	Lenovo	LBH 308	FCC DoC

## 2. CONDUCTED EMISSION TEST

### 2.1 Measuring Instruments

See list of measuring instruments of this test report.

### 2.2 Test setup

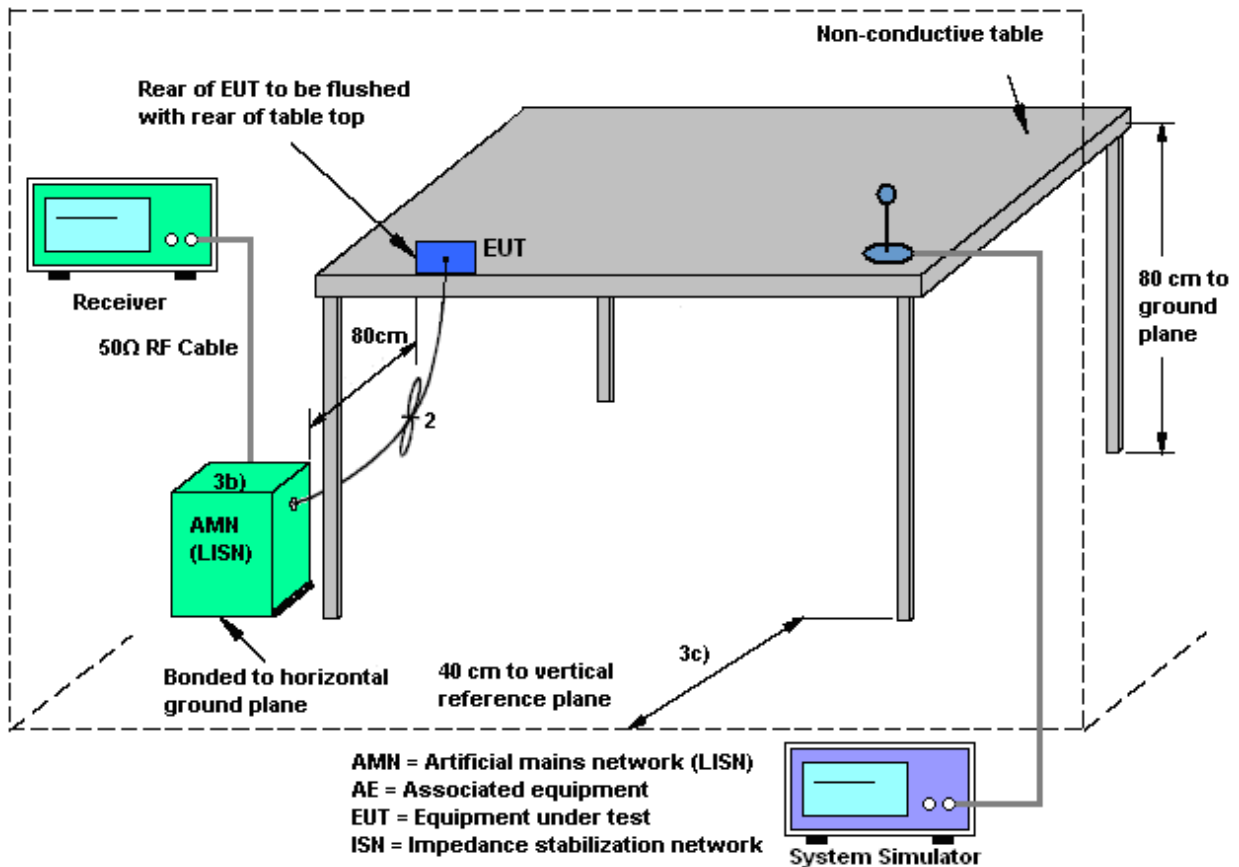

### 2.3 Test Result of Conducted Emission Test

Please refer to Appendix A.



## 2.4 AC Power Line Conducted Emissions Measurement

### 2.4.1 Limit

For equipment that is designed to be connected to the public utility (AC) power line, the radio frequency voltage that is conducted back onto the AC power line on any frequency or frequencies within the band 150 kHz to 30 MHz shall not exceed the limits in the following table.

Frequency of Emission (MHz)	Conducted Limit (dB $\mu$ V)	
	Quasi-Peak	Average
0.15-0.5	66 to 56*	56 to 46*
0.5-5	56	46
5-30	60	50

\*Decreases with the logarithm of the frequency.

### 2.4.2 Test Procedures

1. The EUT was placed 0.4 meter from the conducting wall of the shielding room, and it was kept at least 80 centimeters from any other grounded conducting surface.
2. Connect EUT to the power mains through a line impedance stabilization network (LISN).
3. All the support units are connecting to the other LISN.
4. The LISN provides 50 ohm coupling impedance for the measuring instrument.
5. The FCC states that a 50 ohm, 50 microhenry LISN should be used.
6. Both sides of AC line were checked for maximum conducted interference.
7. The frequency range from 150 kHz to 30 MHz was searched.
8. Set the test-receiver system to Peak Detect Function and specified bandwidth (IF Bandwidth = 9kHz) with Maximum Hold Mode. Then measurement is also conducted by Average Detector and Quasi-Peak Detector Function respectively.

### 3. CONDUCTED TEST ITEMS

#### 3.1 Measuring Instruments

See list of measuring instruments of this test report.

#### 3.2 Test Setup

##### 3.2.1 20dB and 99% OBW Spectrum Bandwidth

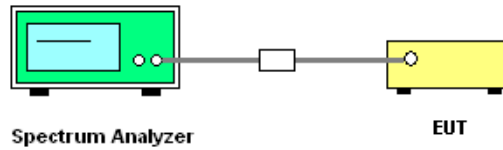

##### 3.2.2 Frequency Stability

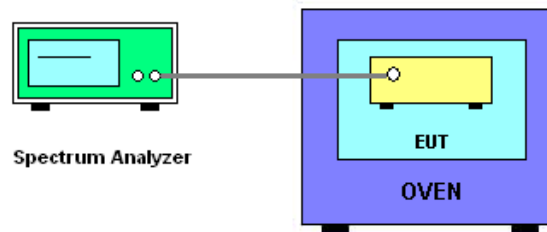

#### 3.3 Test Result of Conducted Test Items

Please refer to Appendix B.



### **3.4 20dB and 99% OBW Spectrum Bandwidth Measurement**

#### **3.4.1 Limit**

Intentional radiators must be designed to ensure that the 20dB and 99% emission bandwidth in the specific band 13.553~13.567MHz

#### **3.4.2 Test Procedures**

1. The transmitter output (antenna port) was connected to the spectrum analyzer in peak Max hold mode.
2. The resolution bandwidth of 1 kHz and the video bandwidth of 3 kHz were used.
3. Measured the spectrum width with power higher than 20dB below carrier.
4. Measured the 99% OBW.

### **3.5 Frequency Stability Measurement**

#### **3.5.1 Limit**

The frequency tolerance of the carrier signal shall be maintained within +/- 0.01% (100ppm) of the operating frequency over a temperature variation of -20 degrees to +50 degrees C at normal supply voltage, and for a variation in the primary supply voltage from 85% to 115% of the rated supply voltage at a temperature of 20 degrees C. For battery operated equipment, the equipment tests shall be performed using a new battery.

#### **3.5.2 Test Procedures**

1. The spectrum analyzer connected via a receive antenna placed near the EUT.
2. EUT have transmitted signal and fixed channelize.
3. Set the spectrum analyzer span to view the entire emissions bandwidth.
4. Set RBW = 1 kHz, VBW = 3 kHz with peak detector and maxhold settings.
5. The  $f_c$  is declaring of channel frequency. Then the frequency error formula is  $(f_c-f)/f_c \times 10^6$  ppm and the limit is less than  $\pm 100$ ppm.
6. Extreme temperature rule is -20°C~50°C.

## 4. RADIATED TEST ITEMS

### 4.1 Measuring Instruments

See list of measuring instruments of this test report.

### 4.2 Test Setup

#### 4.2.1 For radiated emissions below 30MHz

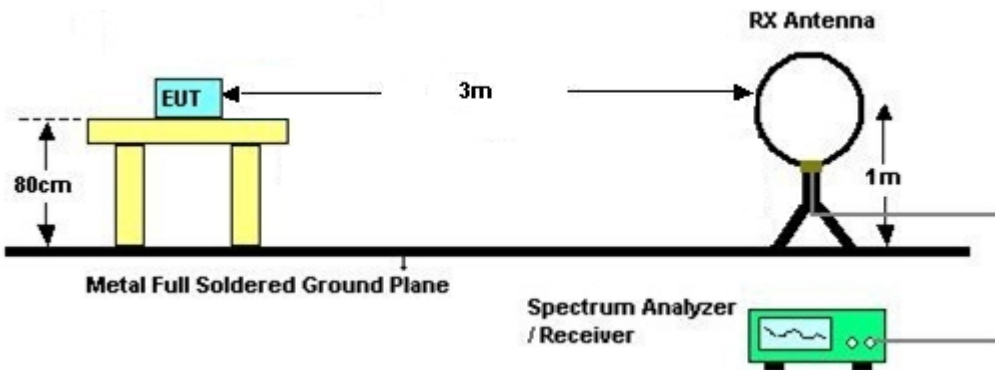

#### 4.2.2 For radiated emissions above 30MHz

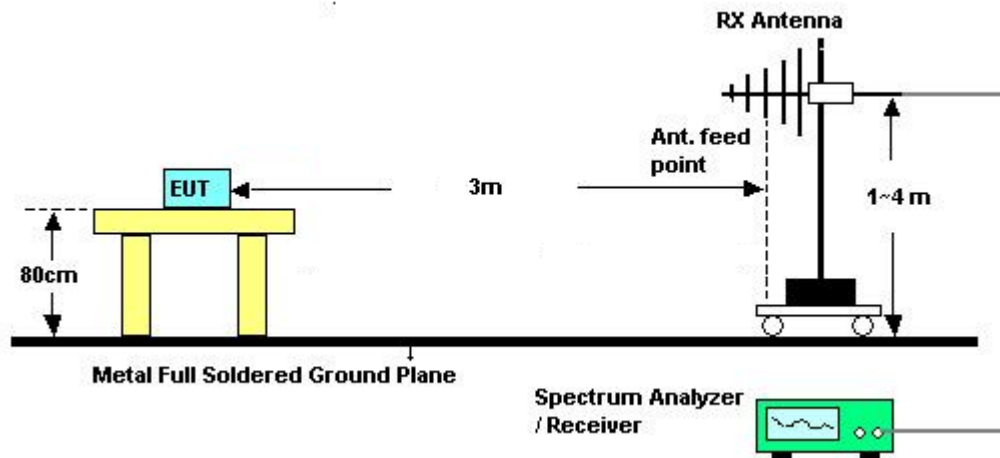

### 4.3 Test Result of Radiated Test Items

Please refer to Appendix C.



### 4.4 Field Strength of Fundamental Emissions and Mask Measurement

#### 4.4.1 Limit

Rules and specifications	FCC CFR 47 Part 15 section 15.225			
Description	Compliance with the spectrum mask is tested with RBW set to 9kHz.			
Freq. of Emission (MHz)	Field Strength (μV/m) at 30m	Field Strength (dBμV/m) at 30m	Field Strength (dBμV/m) at 10m	Field Strength (dBμV/m) at 3m
1.705~13.110	30	29.5	48.58	69.5
13.110~13.410	106	40.5	59.58	80.5
13.410~13.553	334	50.5	69.58	90.5
13.553~13.567	15848	84.0	103.08	124.0
13.567~13.710	334	50.5	69.58	90.5
13.710~14.010	106	40.5	59.58	80.5
14.010~30.000	30	29.5	48.58	69.5

#### 4.4.2 Test Procedures

1. Configure the EUT according to ANSI C63.10. The EUT was placed on the top of the turntable 0.8 meter above ground. The phase center of the loop receiving antenna mounted antenna tower was placed 3 meters far away from the turntable.
2. Power on the EUT and all the supporting units. The turntable was rotated by 360 degrees to determine the position of the highest radiation.
3. The height of the receiving antenna was fixed at one meter above ground to find the maximum emissions field strength.
4. For Fundamental emissions, use the receiver to measure QP reading.
5. When the radiated emissions limits are expressed in terms of the average value of the emissions, and pulsed operation is employed, the measurement field strength shall be determined by averaging over one complete pulse train, including blanking intervals, as long as the pulse train does not exceed 0.1 seconds. As an alternative (provided the transmitter operates for longer than 0.1 seconds) or in cases where the pulse train exceeds 0.1 seconds, the measured field strength shall be determined from the average absolute voltage during a 0.1 second interval during which the field strength is at its maximum value.
6. Compliance with the spectrum mask is tested with RBW set to 9kHz.

Note: Emission level (dBμV/m) = 20 log Emission level (μV/m).

## 4.5 Radiated Emissions Measurement

### 4.5.1 Limit

The field strength of any emissions which appear outside of 13.553~13.567MHz band shall not exceed the general radiated emissions limits.

Frequencies (MHz)	Field Strength ( $\mu\text{V/m}$ )	Measurement Distance (meters)
0.009~0.490	2400/F(kHz)	300
0.490~1.705	24000/F(kHz)	30
1.705~30.0	30	30
30~88	100	3
88~216	150	3
216~960	200	3
Above 960	500	3

### 4.5.2 Measuring Instrument Setting

The following table is the setting of receiver.

Receiver Parameter	Setting
Attenuation	Auto
Frequency Range: 9kHz~150kHz	RBW 200Hz for QP
Frequency Range: 150kHz~30MHz	RBW 9kHz for QP
Frequency Range: 30MHz~1000MHz	RBW 120kHz for Peak

**Note:** The emission limits shown in the above table are based on measurements employing a CISPR quasi-peak detector except for the frequency bands 9-90 kHz, 110-490 kHz. Radiated emission limits in these two bands are based on measurements employing an average detector.

#### **4.5.3 Test Procedures**

1. Configure the EUT according to ANSI C63.10. The EUT was placed on the top of the turntable 0.8 meter above ground. The phase center of the receiving antenna mounted on the top of a height-variable antenna tower was placed 3 meters far away from the turntable.
2. Power on the EUT and all the supporting units. The turntable was rotated by 360 degrees to determine the position of the highest radiation.
3. The height of the broadband receiving antenna was varied between one meter and four meters above ground to find the maximum emissions field strength of both horizontal and vertical polarization.
4. For each suspected emissions, the antenna tower was scan (from 1 M to 4 M) and then the turntable was rotated (from 0 degree to 360 degrees) to find the maximum reading.
5. Set the test-receiver system to Peak or CISPR quasi-peak Detect Function with specified bandwidth under Maximum Hold Mode.
6. When the radiated emissions limits are expressed in terms of the average value of the emissions, and pulsed operation is employed, the measurement field strength shall be determined by averaging over one complete pulse train, including blanking intervals, as long as the pulse train does not exceed 0.1 seconds. As an alternative (provided the transmitter operates for longer than 0.1 seconds) or in cases where the pulse train exceeds 0.1 seconds, the measured field strength shall be determined from the average absolute voltage during a 0.1 second interval during which the field strength is at its maximum value.
7. In case the emission is lower than 30MHz, loop antenna has to be used for measurement and the recorded data should be QP measured by receiver. Antenna Requirements

#### **4.5.4 Limit**

Except for special regulations, the Low-power Radio-frequency Devices must not be equipped with any jacket for installing an antenna with extension cable. An intentional radiator shall be designed to ensure that no antenna other than that furnished by the responsible party shall be used with the device. The use of a permanently attached antenna or of an antenna that uses a unique coupling to the intentional radiator shall be considered sufficient to comply with the provisions of this Section. The manufacturer may design the unit so that the user can replace a broken antenna, but the use of a standard antenna jack or electrical connector is prohibited.

#### **4.5.5 Antenna Anti-Replacement Construction**

An embedded-in antenna design is used.



### 5. LIST OF MEASURING EQUIPMENT

Instrument	Manufacturer	Model No.	Serial No.	Characteristics	Calibration Date	Test Date	Due Date	Remark
Spectrum Analyzer	R&S	FSP40	100319	9kHz~40GHz	Oct. 24, 2015	Dec. 03, 2015	Oct. 23, 2016	Conducted (TH01-KS)
Thermal Chamber	Ten Billion	TTC-B3S	TBN-960502	-40~+150°C	Oct. 24, 2015	Dec. 03, 2015	Oct. 23, 2016	Conducted (TH01-KS)
AC Power Source	Chroma	61601	F104090004	N/A	NCR	Dec. 03, 2015	NCR	Conducted (TH01-KS)
EMI Receiver	R&S	ESC17	100768	9kHz~7GHz;	May 04, 2015	Dec. 03, 2015	May 03, 2016	Conduction (CO01-KS)
AC LISN	MessTec	AN3016	060103	9kHz~30MHz	Oct. 24, 2015	Dec. 03, 2015	Oct. 23, 2016	Conduction (CO01-KS)
AC LISN (for auxiliary equipment)	MessTec	AN3016	060105	9kHz~30MHz	Oct. 24, 2015	Dec. 03, 2015	Oct. 23, 2016	Conduction (CO01-KS)
AC Power Source	Chroma	61602	ABP000000811	AC 0V~300V, 45Hz~1000Hz	Oct. 24, 2015	Dec. 03, 2015	Oct. 23, 2016	Conduction (CO01-KS)
EMI Test Receiver	R&S	ESR7	101403	9kHz~7GHz;Max 30dBm	Sep. 10, 2015	Dec. 08, 2015	Sep. 09, 2016	Radiation (03CH03-KS)
Spectrum Analyzer	R&S	FSP40	100319	9kHz~40GHz	Oct. 24, 2015	Dec. 08, 2015	Oct. 23, 2016	Radiation (03CH03-KS)
Loop Antenna	R&S	HFH2-Z2	100321	9kHz~30MHz	Nov. 10, 2015	Dec. 08, 2015	Nov. 09, 2016	Radiation (03CH03-KS)
Bilog Antenna	TeseQ	CBL6112D	35406	25MHz-2GHz	Jun. 25, 2015	Dec. 08, 2015	Jun. 24, 2016	Radiation (03CH03-KS)
Amplifier	Burgeon	BPA-530	102212	0.01MHz-3000M Hz	Aug.10, 2015	Dec. 08, 2015	Aug. 09, 2016	Radiation (03CH03-KS)
AC Power Source	Chroma	61601	F104090004	N/A	NCR	Dec. 08, 2015	NCR	Radiation (03CH03-KS)
Turn Table	ChamPro	EM 1000-T	060762-T	0~360 degree	NCR	Dec. 08, 2015	NCR	Radiation (03CH03-KS)
Antenna Mast	ChamPro	EM 1000-A	060762-A	1 m~4 m	NCR	Dec. 08, 2015	NCR	Radiation (03CH03-KS)



## Appendix A. Test Results of Conducted Emission Test

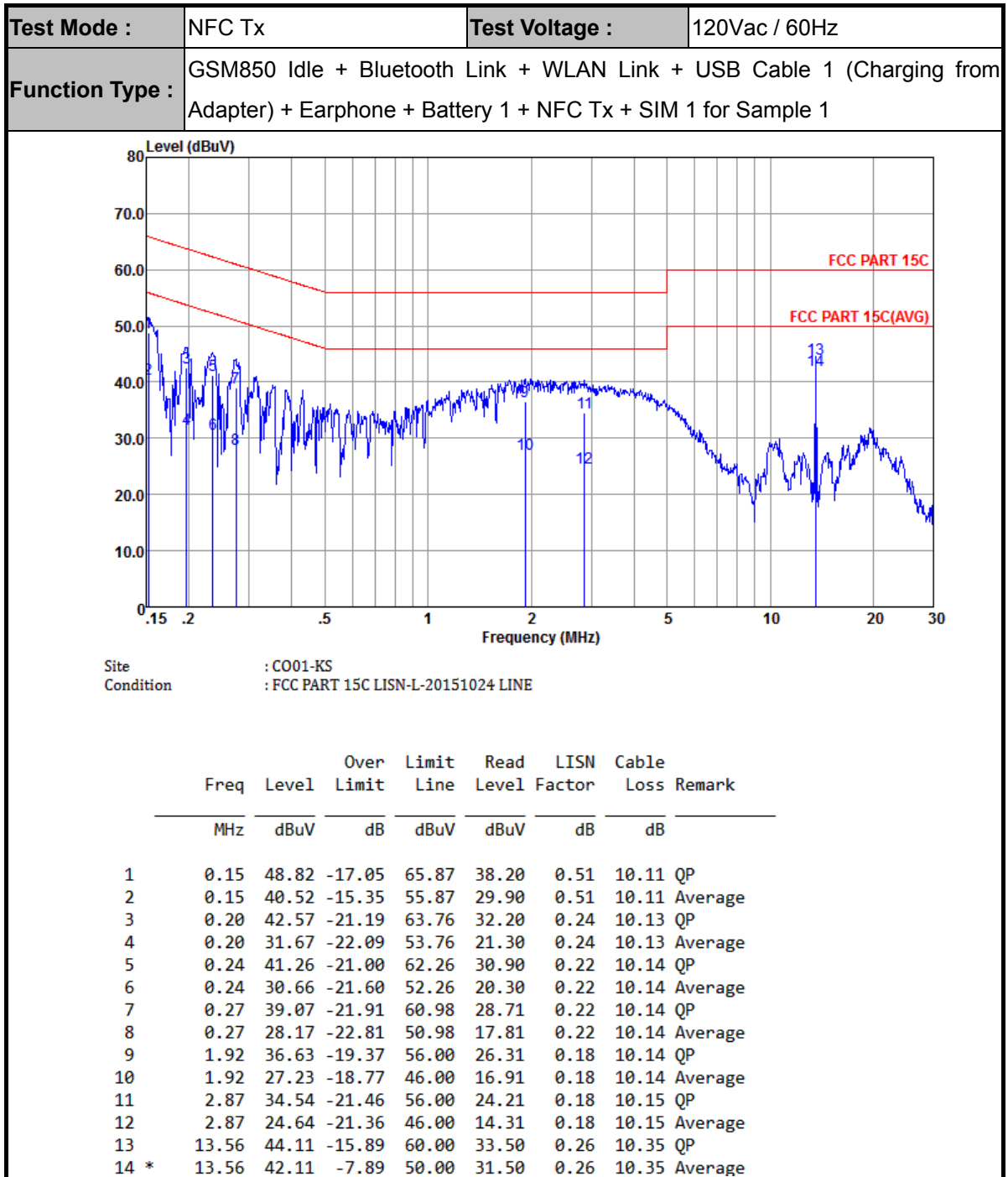

Remark: 13.56MHz is the NFC RF fundamental signal.



Test Mode :	NFC Tx	Test Voltage :	120Vac / 60Hz
Function Type :	GSM850 Idle + Bluetooth Link + WLAN Link + USB Cable 1 (Charging from Adapter) + Earphone + Battery 1 + NFC Tx + SIM 1 for Sample 1		

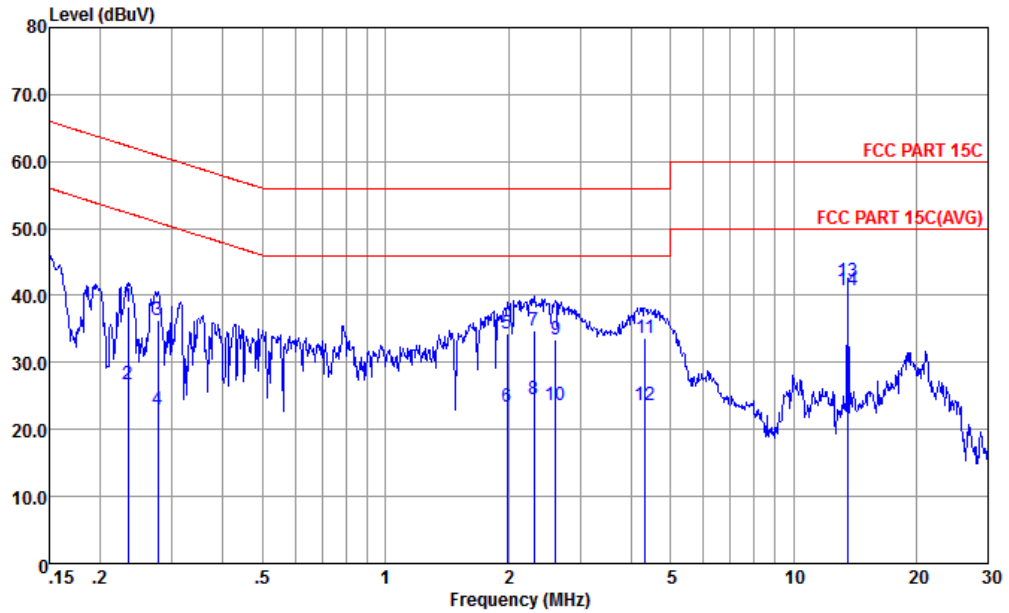

Site : CO01-KS  
 Condition : FCC PART 15C LISN-N-20151024 NEUTRAL

	Freq	Level	Over Limit	Limit Line	Read Level	LISN Factor	Cable Loss	Remark
	MHz	dBuV	dB	dBuV	dBuV	dB	dB	
1	0.23	38.35	-23.95	62.30	27.90	0.31	10.14	QP
2	0.23	26.75	-25.55	52.30	16.30	0.31	10.14	Average
3	0.28	36.36	-24.54	60.90	25.91	0.31	10.14	QP
4	0.28	23.06	-27.84	50.90	12.61	0.31	10.14	Average
5	1.99	34.42	-21.58	56.00	23.90	0.38	10.14	QP
6	1.99	23.42	-22.58	46.00	12.90	0.38	10.14	Average
7	2.31	34.72	-21.28	56.00	24.19	0.38	10.15	QP
8	2.31	24.42	-21.58	46.00	13.89	0.38	10.15	Average
9	2.61	33.42	-22.58	56.00	22.90	0.37	10.15	QP
10	2.61	23.62	-22.38	46.00	13.10	0.37	10.15	Average
11	4.34	33.63	-22.37	56.00	23.10	0.36	10.17	QP
12	4.34	23.63	-22.37	46.00	13.10	0.36	10.17	Average
13	13.56	42.02	-17.98	60.00	31.40	0.27	10.35	QP
14 *	13.56	40.82	-9.18	50.00	30.20	0.27	10.35	Average

Remark: 13.56MHz is the NFC RF fundamental signal.



## Appendix B. Test Results of Conducted Test Items

### B.1 Test Result of 20dB Spectrum Bandwidth

Test mode	NFC Tx	Test Frequency (MHz)	13.56																																																																
<table border="1"> <thead> <tr> <th>Marker</th> <th>Type</th> <th>Ref</th> <th>Trc</th> <th>X-value</th> <th>Y-value</th> <th>Function</th> <th>Function Result</th> </tr> </thead> <tbody> <tr> <td>M1</td> <td>1</td> <td></td> <td></td> <td>13.56 MHz</td> <td>-23.43 dBm</td> <td>ndB down</td> <td>2.489 kHz</td> </tr> <tr> <td>T1</td> <td>1</td> <td></td> <td></td> <td>13.558755 MHz</td> <td>-43.54 dBm</td> <td>ndB</td> <td>20.00 dB</td> </tr> <tr> <td>T2</td> <td>1</td> <td></td> <td></td> <td>13.561245 MHz</td> <td>-43.48 dBm</td> <td>Q factor</td> <td>5447.7</td> </tr> </tbody> </table>		Marker	Type	Ref	Trc	X-value	Y-value	Function	Function Result	M1	1			13.56 MHz	-23.43 dBm	ndB down	2.489 kHz	T1	1			13.558755 MHz	-43.54 dBm	ndB	20.00 dB	T2	1			13.561245 MHz	-43.48 dBm	Q factor	5447.7	<table border="1"> <thead> <tr> <th>Marker</th> <th>Type</th> <th>Ref</th> <th>Trc</th> <th>X-value</th> <th>Y-value</th> <th>Function</th> <th>Function Result</th> </tr> </thead> <tbody> <tr> <td>M1</td> <td>1</td> <td></td> <td></td> <td>13.56 MHz</td> <td>-23.92 dBm</td> <td></td> <td></td> </tr> <tr> <td>T1</td> <td>1</td> <td></td> <td></td> <td>13.5589436 MHz</td> <td>-37.99 dBm</td> <td>Occ Bw</td> <td>2.112879884 kHz</td> </tr> <tr> <td>T2</td> <td>1</td> <td></td> <td></td> <td>13.5610564 MHz</td> <td>-37.92 dBm</td> <td></td> <td></td> </tr> </tbody> </table>		Marker	Type	Ref	Trc	X-value	Y-value	Function	Function Result	M1	1			13.56 MHz	-23.92 dBm			T1	1			13.5589436 MHz	-37.99 dBm	Occ Bw	2.112879884 kHz	T2	1			13.5610564 MHz	-37.92 dBm		
Marker	Type	Ref	Trc	X-value	Y-value	Function	Function Result																																																												
M1	1			13.56 MHz	-23.43 dBm	ndB down	2.489 kHz																																																												
T1	1			13.558755 MHz	-43.54 dBm	ndB	20.00 dB																																																												
T2	1			13.561245 MHz	-43.48 dBm	Q factor	5447.7																																																												
Marker	Type	Ref	Trc	X-value	Y-value	Function	Function Result																																																												
M1	1			13.56 MHz	-23.92 dBm																																																														
T1	1			13.5589436 MHz	-37.99 dBm	Occ Bw	2.112879884 kHz																																																												
T2	1			13.5610564 MHz	-37.92 dBm																																																														
Date: 3.DEC.2015 16:34:22		Date: 3.DEC.2015 16:32:17																																																																	
<b>20dB Bandwidth (kHz)</b>	2.49	<b>99% Occupied BW (kHz)</b>	2.11																																																																
<b>Frequency range (MHz)</b>	$f_L > 13.553$	13.558755	<b>Test Result</b>																																																																
	$f_H < 13.567$	13.561245	<b>Complies</b>																																																																



B.2 Test Result of Frequency Stability

Voltage vs. Frequency Stability		Temperature vs. Frequency Stability	
Voltage (Vac)	Measurement Frequency (MHz)	Temperature (°C)	Measurement Frequency (MHz)
120	13.560000	-20	13.560000
102	13.560000	-10	13.560000
138	13.560000	0	13.560000
-	-	10	13.560000
-	-	20	13.560000
-	-	30	13.560000
-	-	40	13.560000
-	-	50	13.560000
<b>Max.Deviation (MHz)</b>	0.000000	<b>Max.Deviation (MHz)</b>	0.000000
<b>Max.Deviation (ppm)</b>	0.0000	<b>Max.Deviation (ppm)</b>	0.0000
<b>Limit</b>	<b>FS &lt; ±100 ppm</b>	<b>Limit</b>	<b>FS &lt; ±100 ppm</b>
<b>Test Result</b>	<b>PASS</b>	<b>Test Result</b>	<b>PASS</b>



## Appendix C. Test Results of Radiated Test Items

### C.1 Test Result of Field Strength of Fundamental Emissions

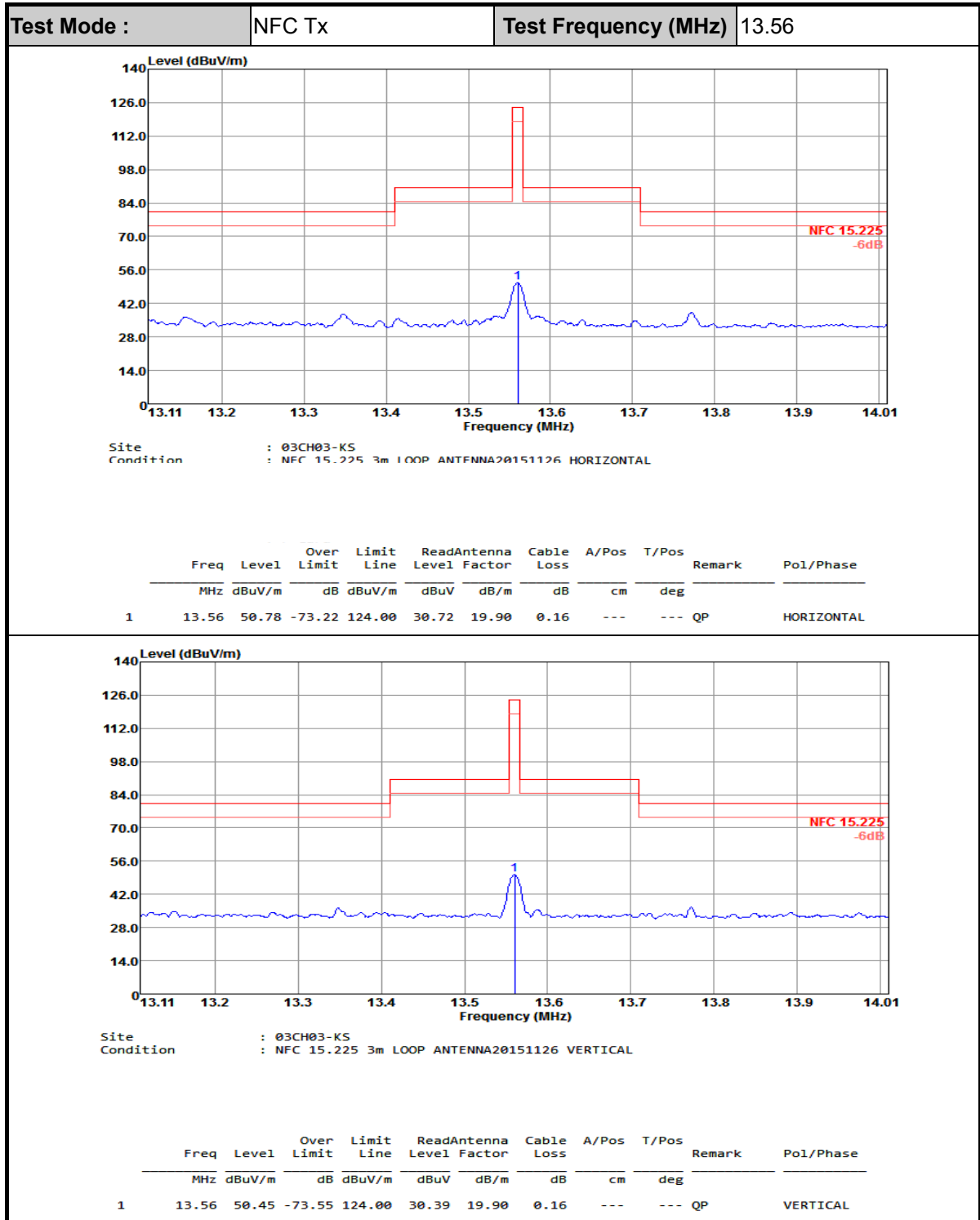

**Note:** All NFC's spurious emissions are below 20dB of limits.

**C.2 Results of Radiated Emissions (9 kHz~30MHz)**

Test Mode :		NFC Tx			Polarization :		Horizontal		
Frequency ( MHz )	Level ( dB $\mu$ V/m )	Over Limit ( dB )	Limit Line ( dB $\mu$ V/m )	Read Level ( dB $\mu$ V )	Antenna Factor ( dB )	Cable Loss ( dB )	Ant Pos ( cm )	Table Pos ( deg )	Remark
0.02663	35.11	-83.98	119.09	14.7	20.4	0.01	-	-	Average
0.05257	36.27	-76.91	113.18	15.86	20.4	0.01	-	-	Average
0.06526	35.83	-75.47	111.3	15.47	20.35	0.01	-	-	Average
0.08556	34.67	-74.28	108.95	14.36	20.3	0.01	-	-	Average
0.2055	43.02	-58.31	101.33	22.54	20.47	0.01	-	-	Average
3.896	38.93	-30.61	69.54	19.08	19.8	0.05	-	-	QP
12.437	35.98	-33.56	69.54	15.87	19.96	0.15	-	-	QP
28.225	32.15	-37.39	69.54	11.27	20.56	0.32	-	-	QP

Test Mode :		NFC Tx			Polarization :		Vertical		
Frequency ( MHz )	Level ( dB $\mu$ V/m )	Over Limit ( dB )	Limit Line ( dB $\mu$ V/m )	Read Level ( dB $\mu$ V )	Antenna Factor ( dB )	Cable Loss ( dB )	Ant Pos ( cm )	Table Pos ( deg )	Remark
0.03227	32.42	-85	117.42	12.01	20.4	0.01	-	-	Average
0.04157	32.6	-82.62	115.22	12.19	20.4	0.01	-	-	Average
0.06455	31.87	-79.53	111.4	11.51	20.35	0.01	-	-	Average
1.682	48.35	-14.73	63.08	28.55	19.77	0.03	-	-	QP
1.782	50.16	-19.38	69.54	30.35	19.78	0.03	-	-	QP
2.072	41.13	-28.41	69.54	21.3	19.8	0.03	-	-	QP
12.148	35.54	-34	69.54	15.42	19.98	0.14	-	-	QP
29.81	37.94	-31.6	69.54	16.91	20.69	0.34	-	-	QP

**Note:**

- 13.56 MHz is fundamental signal which can be ignored.
- The amplitude of spurious emissions which are attenuated by more than 20dB below the permissible value has no need to be reported.
- Distance extrapolation factor =  $40 \log(\text{specific distance} / \text{test distance})$  (dB);
- Limit line = specific limits (dB $\mu$ V) + distance extrapolation factor.



**C.3 Results of Radiated Emissions (30MHz~1GHz)**

Test Mode :		NFC Tx			Polarization :		Horizontal			
Frequency ( MHz )	Level ( dBμV/m )	Over Limit ( dB )	Limit Line ( dBμV/m )	Read Level ( dBμV )	Antenna Factor ( dB )	Cable Loss ( dB )	Preamp Factor ( dB )	Ant Pos ( cm )	Table Pos ( deg )	Remark
33.88	19.85	-20.15	40	32.55	17.24	1	30.94	100	214	Peak
129.91	16.79	-26.71	43.5	33.8	11.54	1.85	30.4	-	-	Peak
138.64	17.17	-26.33	43.5	34.08	11.61	1.88	30.4	-	-	Peak
154.16	17.11	-26.39	43.5	33.9	11.55	2.06	30.4	-	-	Peak
625.58	21.97	-24.03	46	28.87	19.11	4.24	30.25	-	-	Peak
849.65	23.18	-22.82	46	27.61	21	4.97	30.4	-	-	Peak

Test Mode :		NFC Tx			Polarization :		Vertical			
Frequency ( MHz )	Level ( dBμV/m )	Over Limit ( dB )	Limit Line ( dBμV/m )	Read Level ( dBμV )	Antenna Factor ( dB )	Cable Loss ( dB )	Preamp Factor ( dB )	Ant Pos ( cm )	Table Pos ( deg )	Remark
33.88	31.53	-8.47	40	44.23	17.24	1	30.94	139	54	Peak
54.25	20.52	-19.48	40	42.37	7.66	1.19	30.7	-	-	Peak
96.93	15.01	-28.49	43.5	32.83	10.97	1.61	30.4	-	-	Peak
164.83	13.71	-29.79	43.5	30.85	11.14	2.12	30.4	-	-	Peak
704.15	23.28	-22.72	46	28.99	20.02	4.68	30.41	-	-	Peak
878.75	24.54	-21.46	46	28.04	21.98	5.04	30.52	-	-	Peak

**Note:**

1. The amplitude of spurious emissions which are attenuated by more than 20dB below the permissible value has no need to be reported.
2. Emission level (dBμV/m) = 20 log Emission level (μV/m).
3. Corrected Reading: Antenna Factor + Cable Loss + Read Level - Preamp Factor= Level.