

FCC RF Test Report

APPLICANT : Lenovo Mobile Communication Technology Ltd.
EQUIPMENT : Lenovo Mobile Phone
BRAND NAME : lenovo
MODEL NAME : Lenovo A516
MID : 51600031
FCC ID : YCNA516
STANDARD : FCC Part 15 Subpart C §15.247
CLASSIFICATION : (DTS) Digital Transmission System

The product was received on Jun. 14, 2013 and completely tested on Jun. 19, 2013. We, SPORTON INTERNATIONAL (KUNSHAN) INC., would like to declare that the tested sample has been evaluated in accordance with the procedures and shown the compliance with the applicable technical standards.

The test results in this report apply exclusively to the tested model / sample. Without written approval of SPORTON INTERNATIONAL (KUNSHAN) INC., the test report shall not be reproduced except in full.



Reviewed by: Joseph Lin / Supervisor



Approved by: Jones Tsai / Manager



SPORTON INTERNATIONAL (KUNSHAN) INC.
No. 3-2, PingXiang Road, Kunshan, Jiangsu Province, P.R.C.



TABLE OF CONTENTS

REVISION HISTORY..... 3

SUMMARY OF TEST RESULT 4

1 GENERAL DESCRIPTION 5

 1.1 Applicant 5

 1.2 Manufacturer 5

 1.3 Feature of Equipment Under Test 5

 1.4 Product Specification of Equipment Under Test 5

 1.5 Modification of EUT 5

 1.6 Testing Site 6

 1.7 Applied Standards 6

2 TEST CONFIGURATION OF EQUIPMENT UNDER TEST 7

 2.1 Carrier Frequency Channel 7

 2.2 Pre-Scanned RF Power 8

 2.3 Test Mode 9

 2.4 Connection Diagram of Test System 10

 2.5 Support Unit used in test configuration and system 11

 2.6 EUT Operation Test Setup 11

 2.7 Measurement Results Explanation Example 12

3 TEST RESULT 13

 3.1 6dB Bandwidth Measurement 13

 3.2 Output Power Measurement 21

 3.3 Power Spectral Density Measurement 24

 3.4 Conducted Band Edges and Spurious Emission Measurement 39

 3.5 Radiated Band Edges and Spurious Emission Measurement 56

 3.6 AC Conducted Emission Measurement 88

 3.7 Antenna Requirements 92

4 LIST OF MEASURING EQUIPMENT 93

5 UNCERTAINTY OF EVALUATION 94

APPENDIX A. PHOTOGRAPHS OF EUT

APPENDIX B. SETUP PHOTOGRAPHS



REVISION HISTORY

REPORT NO.	VERSION	DESCRIPTION	ISSUED DATE
FR361405C	Rev. 01	Initial issue of report	Jun. 26, 2013

SUMMARY OF TEST RESULT

Report Section	FCC Rule	Description	Limit	Result	Remark
3.1	15.247(a)(2)	6dB Bandwidth	$\geq 0.5\text{MHz}$	Pass	-
3.2	15.247(b)	Power Output Measurement	$\leq 30\text{dBm}$	Pass	-
3.3	15.247(e)	Power Spectral Density	$\leq 8\text{dBm}/3\text{kHz}$	Pass	-
3.4	15.247(d)	Conducted Band Edges	$\leq 20\text{dBc}$	Pass	-
		Conducted Spurious Emission		Pass	-
3.5	15.247(d)	Radiated Band Edges and Radiated Spurious Emission	15.209(a) & 15.247(d)	Pass	Under limit 3.31 dB at 2483.800 MHz
3.6	15.207	AC Conducted Emission	15.207(a)	Pass	Under limit 12.91 dB at 0.150 MHz
3.7	15.203 & 15.247(b)	Antenna Requirement	N/A	Pass	-

1 General Description

1.1 Applicant

Lenovo Mobile Communication Technology Ltd.

No.999, Qishan North 2nd Road, Information & Optoelectronics Park, Torch Hi-tech Industry Development Zone, Xiamen, P.R.China

1.2 Manufacturer

Lenovo PC HK Limited

23/F, Lincoln House, Taikoo Place 979 King's Road, Quarry Bay, Hong Kong

1.3 Feature of Equipment Under Test

Product Feature	
Equipment	Lenovo Mobile Phone
Brand Name	lenovo
Model Name	Lenovo A516
MID	51600031
FCC ID	YCNA516
EUT supports Radios application	GSM/GPRS/EGPRS/WCDMA/HSPA/HSPA+ (Downlink Only)/WLAN 11bgn/Bluetooth 2.1/3.0/4.0
HW Version	A516.FCC.V3
SW Version	A516_ROW_S100_130521
EUT Stage	Production Unit

Remark: The above EUT's information was declared by manufacturer. Please refer to the specifications or user's manual for more detailed description.

1.4 Product Specification of Equipment Under Test

Product Specification subjective to this standard	
Tx/Rx Channel Frequency Range	2412 MHz ~ 2462 MHz
Maximum Output Power to Antenna	802.11b : 18.52 dBm (0.0711 W) 802.11g : 22.39 dBm (0.1734 W) 802.11n HT20 : 22.51 dBm (0.1782 W) 802.11n HT40 : 22.54 dBm (0.1795 W)
Antenna Type	PIFA Antenna type with gain 1.00 dBi
Type of Modulation	802.11b : DSSS (DBPSK / DQPSK / CCK) 802.11g/n : OFDM (BPSK / QPSK / 16QAM / 64QAM)

1.5 Modification of EUT

No modifications are made to the EUT during all test items.

1.6 Testing Site

Test Site	SPORTON INTERNATIONAL (KUNSHAN) INC.			
Test Site Location	No. 3-2, PingXiang Road, Kunshan, Jiangsu Province, P.R.C. TEL: +86-0512-5790-0158 FAX: +86-0512-5790-0958			
Test Site No.	Sporton Site No.			FCC/IC Registration No.
	TH01-KS	CO01-KS	03CH01-KS	149928/4086E-1

Note: The test site complies with ANSI C63.4 2003 requirement.

1.7 Applied Standards

According to the specifications of the manufacturer, the EUT must comply with the requirements of the following standards:

- ♦ FCC Part 15 Subpart C §15.247
- ♦ FCC KDB Publication No. 558074 D01 DTS Meas. Guidance v03r01
- ♦ ANSI C63.10-2009

Remark:

1. All test items were verified and recorded according to the standards and without any deviation during the test.
2. This EUT has also been tested and complied with the requirements of FCC Part 15, Subpart B, recorded in a separate test report.

2 Test Configuration of Equipment Under Test

The EUT has been associated with peripherals and configuration operated in a manner tended to maximize its emission characteristics in a typical application. Frequency range investigated: conducted emission (150 kHz to 30 MHz) and radiated emission (9 kHz to the 10th harmonic of the highest fundamental frequency or to 40 GHz, whichever is lower). For radiated measurement, pre-scanned in three orthogonal panels, X, Y, Z. The worst cases (Y plane) were recorded in this report.

The final configuration from all the combinations and the worst-case data rates were investigated by measuring the maximum power across all the data rates and modulation modes under section 2.2.

Based on the worst configuration found above, the RF power setting is set individually to meet FCC compliance limit for the final conducted and radiated tests shown in section 2.3.

2.1 Carrier Frequency Channel

Frequency Band	Channel	Freq. (MHz)	Channel	Freq. (MHz)
2400-2483.5 MHz	1	2412	7	2442
	2	2417	8	2447
	3	2422	9	2452
	4	2427	10	2457
	5	2432	11	2462
	6	2437		

2.2 Pre-Scanned RF Power

Preliminary tests were performed in different data rate and antenna configurations as following table and the highest power data rates were chosen for full test in the following tables.

Channel	Frequency	2.4GHz 802.11b RF Power (dBm)			
		DSSS Data Rate			
		1 Mbps	2 Mbps	5.5 Mbps	11 Mbps
CH 01	2412 MHz	18.48	18.25	18.16	18.21
CH 06	2437 MHz	18.52	18.43	18.36	18.27
CH 11	2462 MHz	18.44	18.32	18.28	18.17

Channel	Frequency	2.4GHz 802.11g RF Power (dBm)							
		OFDM Data Rate							
		6 Mbps	9 Mbps	12 Mbps	18 Mbps	24 Mbps	36 Mbps	48 Mbps	54 Mbps
CH 01	2412 MHz	22.39	22.36	22.27	22.21	22.18	22.14	22.07	21.96
CH 06	2437 MHz	22.30	22.28	22.16	21.83	21.74	21.65	21.53	21.42
CH 11	2462 MHz	22.36	22.27	22.12	21.94	21.87	21.72	21.56	21.37

Channel	Frequency	2.4GHz 802.11n HT20 RF Power (dBm)							
		OFDM Data Rate							
		6.5 Mbps	13 Mbps	19.5 Mbps	26 Mbps	39 Mbps	52 Mbps	58.5 Mbps	65 Mbps
CH 01	2412 MHz	22.51	22.43	22.31	22.17	21.96	21.84	21.73	21.52
CH 06	2437 MHz	22.48	22.36	22.18	21.94	21.76	21.53	21.37	21.03
CH 11	2462 MHz	21.32	21.12	21.09	21.17	20.98	20.85	20.71	20.39

Channel	Frequency	2.4GHz 802.11n HT40 RF Power (dBm)							
		OFDM Data Rate							
		13.5 Mbps	27 Mbps	40.5 Mbps	54 Mbps	81 Mbps	108 Mbps	121.5 Mbps	135 Mbps
CH 03	2422 MHz	20.86	19.54	19.26	19.41	19.44	19.32	19.56	19.51
CH 06	2437 MHz	22.54	22.11	21.89	21.75	21.64	21.47	21.14	20.98
CH 09	2452 MHz	21.02	19.37	19.18	19.02	19.56	19.39	19.60	19.63

2.3 Test Mode

Final results of test modes, data rates and test channels are shown as following table.

Test Cases				
	Test Items	Mode	Data Rate	Test Channel
Conducted TCs	6dB BW Power Spectral Density	802.11b	1 Mbps	1/6/11
		802.11g	6 Mbps	1/6/11
		802.11n HT20	6.5 Mbps	1/6/11
		802.11n HT40	13.5 Mbps	3/6/9
	Output Power	802.11b	1 Mbps	1/6/11
		802.11g	6 Mbps	1/6/11
		802.11n HT20	6.5 Mbps	1/6/11
		802.11n HT40	13.5 Mbps	3/6/9
	Conducted Band Edge	802.11b	1 Mbps	1/11
		802.11g	6 Mbps	1/11
		802.11n HT20	6.5 Mbps	1/11
		802.11n HT40	13.5 Mbps	3/9
	Conducted Spurious Emission	802.11b	1 Mbps	1/6/11
		802.11g	6 Mbps	1/6/11
		802.11n HT20	6.5 Mbps	1/6/11
		802.11n HT40	13.5 Mbps	3/6/9
Radiated TCs	Radiated Band Edge	802.11b	1 Mbps	1/11
		802.11g	6 Mbps	1/11
		802.11n HT20	6.5 Mbps	1/11
		802.11n HT40	13.5 Mbps	3/9
	Radiated Spurious Emission	802.11b	1 Mbps	1/6/11
		802.11g	6 Mbps	1/6/11
		802.11n HT20	6.5 Mbps	1/6/11
		802.11n HT40	13.5 Mbps	3/6/9
AC Conducted Emission	Mode 1 : GSM850 Idle + Bluetooth Link + WLAN Link + USB Cable (Charging from Adapter) + Earphone			

2.4 Connection Diagram of Test System

<WLAN Tx Mode>

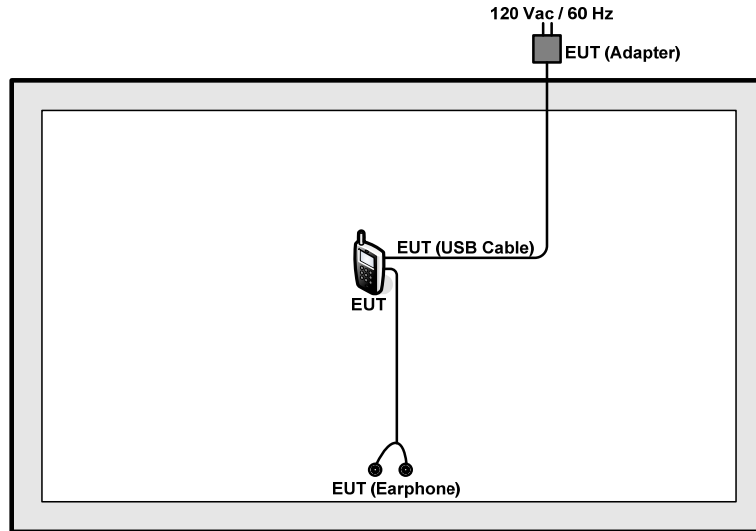

<AC Conducted Emission Mode>

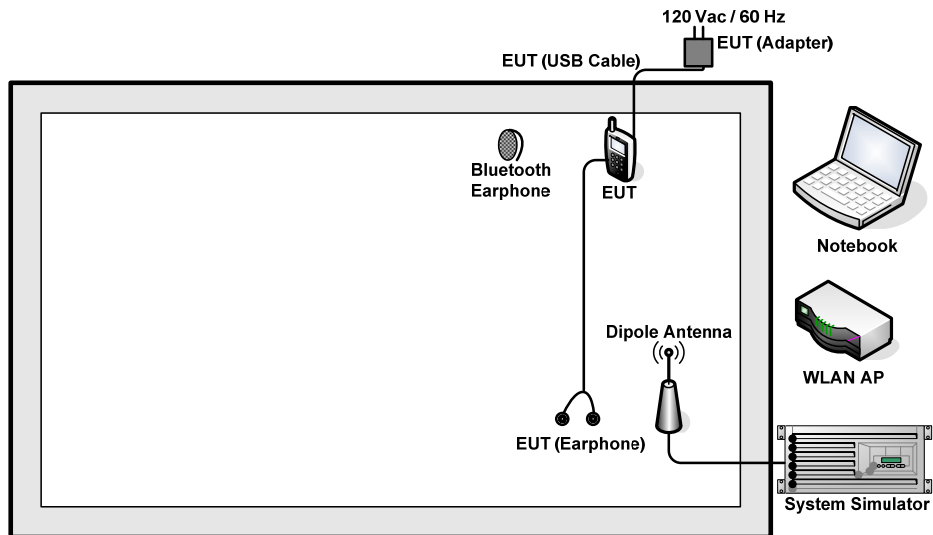

2.5 Support Unit used in test configuration and system

Item	Equipment	Trade Name	Model Name	FCC ID	Data Cable	Power Cord
1.	System Simulator	R&S	CMU 200	N/A	N/A	Unshielded, 1.8 m
2.	DC Power Supply	GWINSTEK	GPS-3030D	N/A	N/A	Unshielded, 1.8 m
3.	WLAN AP	D-Link	DIR-855	KA2DIR855A2	N/A	Unshielded, 1.8 m
4.	Notebook	Lenovo	G480	PPD-AR5B195	N/A	AC I/P: Unshielded, 0.9 m DC O/P: Shielded, 1.8 m
5.	Bluetooth Earphone	Lenovo	LBH301	N/A	N/A	N/A

2.6 EUT Operation Test Setup

For WLAN function, key in “# # # #2516#” on the EUT directly. Then, the EUT will get into the engineering modes to contact with WLAN AP for continuous transmitting and receiving signals.



2.7 Measurement Results Explanation Example

For all conducted test items:

The offset level is set in the spectrum analyzer to compensate the RF cable loss and attenuator factor between EUT conducted output port and spectrum analyzer. With the offset compensation, the spectrum analyzer reading level is exactly the EUT RF output level.

The spectrum analyzer offset is derived from RF cable loss and attenuator factor.

Offset = RF cable loss + attenuator factor.

Following shows an offset computation example with cable loss 5.6 dB and 10dB attenuator.

Example:

$$\begin{aligned} \text{Offset(dB)} &= \text{RF cable loss(dB)} + \text{attenuator factor(dB)}. \\ &= 5.6 + 10 = 15.6 \text{ (dB)} \end{aligned}$$

3 Test Result

3.1 6dB Bandwidth Measurement

3.1.1 Limit of 6dB Bandwidth

The minimum 6 dB bandwidth shall be at least 500 kHz.

3.1.2 Measuring Instruments

See list of measuring instruments of this test report.

3.1.3 Test Procedures

1. The testing follows FCC KDB Publication No. 558074 DTS D01 Meas. Guidance v03r01.
2. The RF output of EUT was connected to the spectrum analyzer by RF cable and attenuator. The path loss was compensated to the results for each measurement.
3. Set to the maximum power setting and enable the EUT transmit continuously.
4. Make the measurement with the spectrum analyzer's resolution bandwidth (RBW) = 100 kHz. Set the Video bandwidth (VBW) = 300 kHz. In order to make an accurate measurement. The 6 dB bandwidth must be greater than 500 kHz.
5. Measure and record the results in the test report.

3.1.4 Test Setup

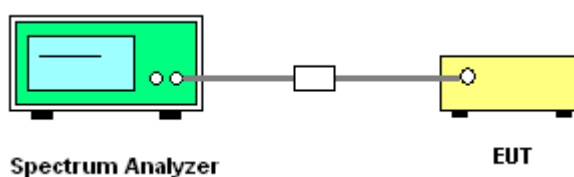

3.1.5 Test Result of 6dB Bandwidth

Test Mode :	802.11b	Temperature :	23~24°C
Test Engineer :	Adonis Li	Relative Humidity :	47~48%

Channel	Frequency (MHz)	802.11b 6dB Bandwidth (MHz)	6dB Bandwidth Min. Limit (MHz)	Pass/Fail
01	2412	10.00	0.5	Pass
06	2437	9.52	0.5	Pass
11	2462	10.00	0.5	Pass

Test Mode :	802.11g	Temperature :	23~24°C
Test Engineer :	Adonis Li	Relative Humidity :	47~48%

Channel	Frequency (MHz)	802.11g 6dB Bandwidth (MHz)	6dB Bandwidth Min. Limit (MHz)	Pass/Fail
01	2412	15.64	0.5	Pass
06	2437	15.32	0.5	Pass
11	2462	15.76	0.5	Pass

Test Mode :	802.11n HT20	Temperature :	23~24°C
Test Engineer :	Adonis Li	Relative Humidity :	47~48%

Channel	Frequency (MHz)	2.4GHz 802.11n HT20 6dB Bandwidth (MHz)	6dB Bandwidth Min. Limit (MHz)	Pass/Fail
01	2412	17.60	0.5	Pass
06	2437	17.60	0.5	Pass
11	2462	17.60	0.5	Pass

Test Mode :	802.11n HT40	Temperature :	23~24°C
Test Engineer :	Adonis Li	Relative Humidity :	47~48%

Channel	Frequency (MHz)	2.4GHz 802.11n HT40 6dB Bandwidth (MHz)	6dB Bandwidth Min. Limit (MHz)	Pass/Fail
03	2422	35.12	0.5	Pass
06	2437	35.12	0.5	Pass
09	2452	35.12	0.5	Pass



3.1.6 Test Result of 6dB Bandwidth Plots

6 dB Bandwidth Plot on 802.11b Channel 01

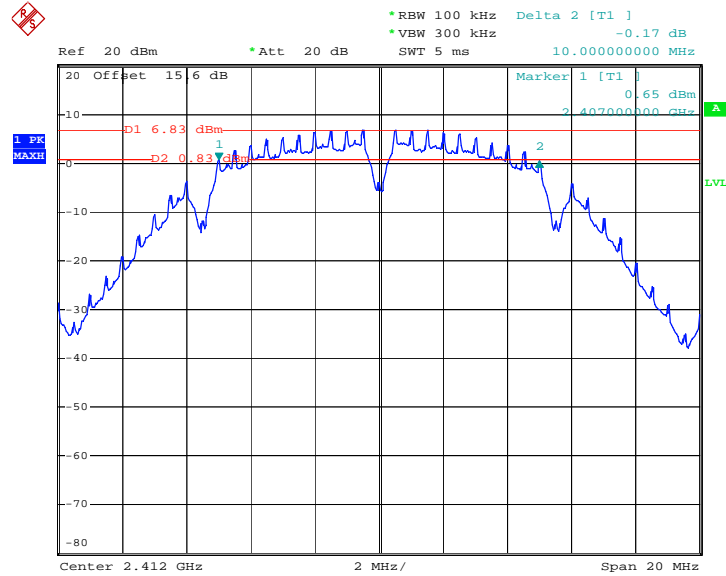

Date: 14.JUN.2013 19:37:52

6 dB Bandwidth Plot on 802.11b Channel 06

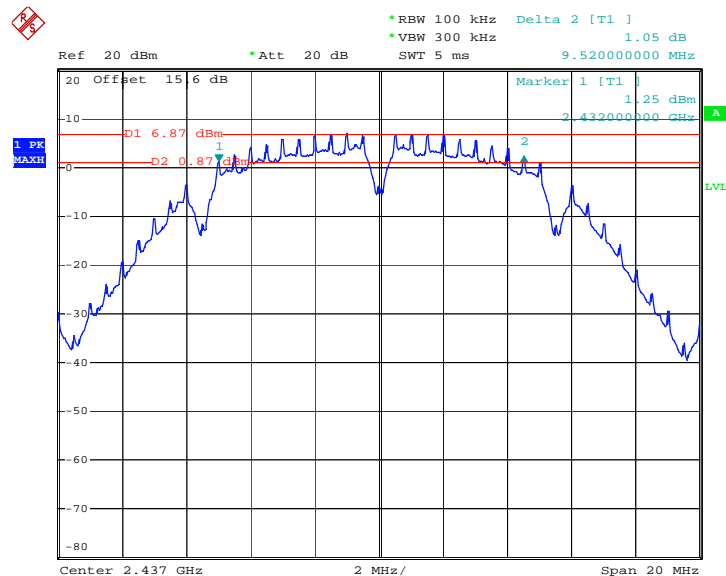

Date: 15.JUN.2013 18:33:41



6 dB Bandwidth Plot on 802.11b Channel 11

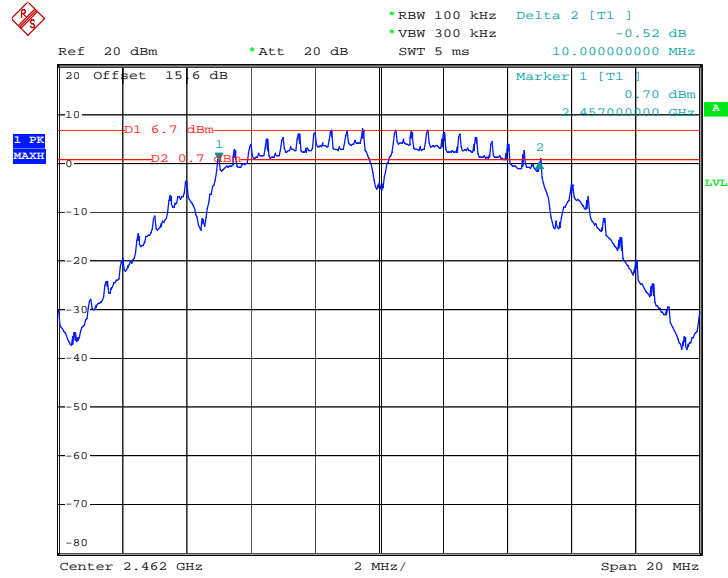

Date: 14.JUN.2013 19:53:36

6 dB Bandwidth Plot on 802.11g Channel 01

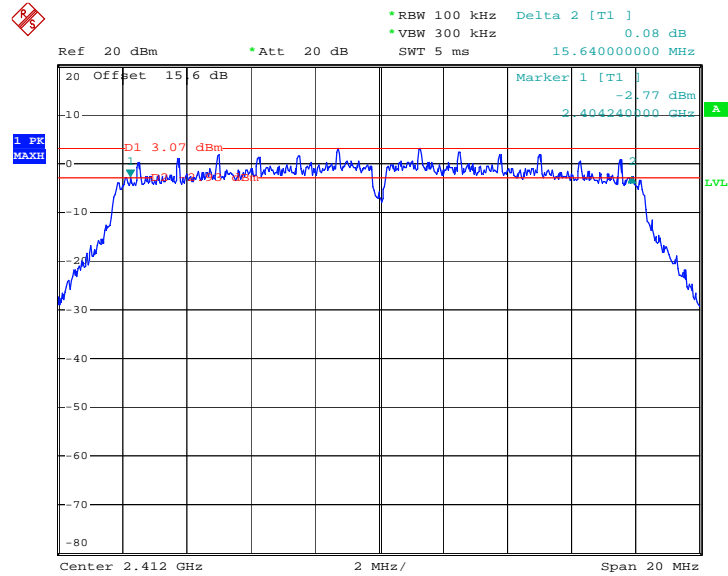

Date: 14.JUN.2013 20:53:34



6 dB Bandwidth Plot on 802.11g Channel 06

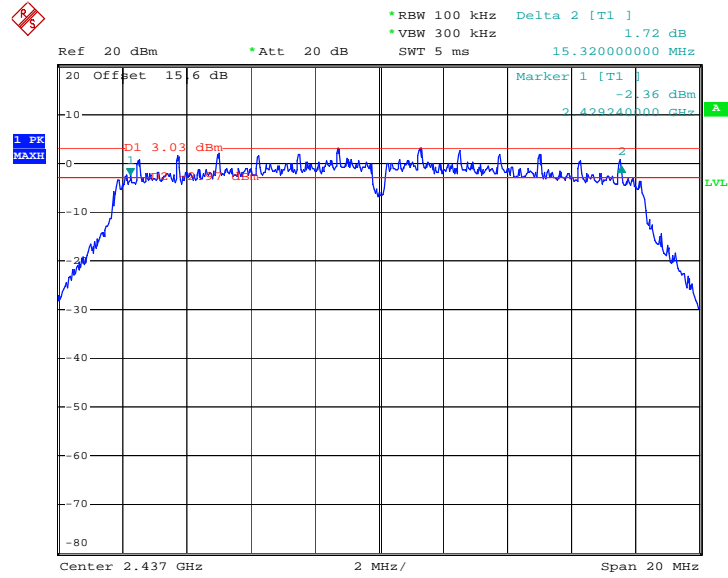

Date: 14.JUN.2013 21:08:20

6 dB Bandwidth Plot on 802.11g Channel 11

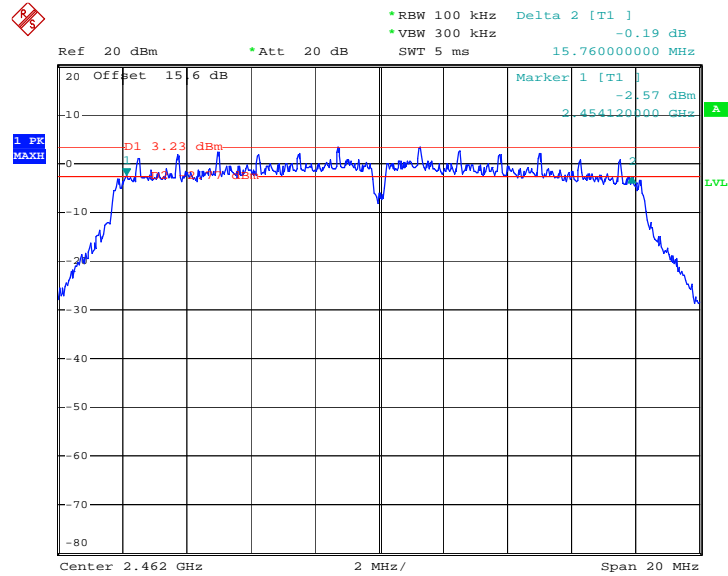

Date: 14.JUN.2013 21:10:49



6 dB Bandwidth Plot on 2.4GHz 802.11n HT20 Channel 01

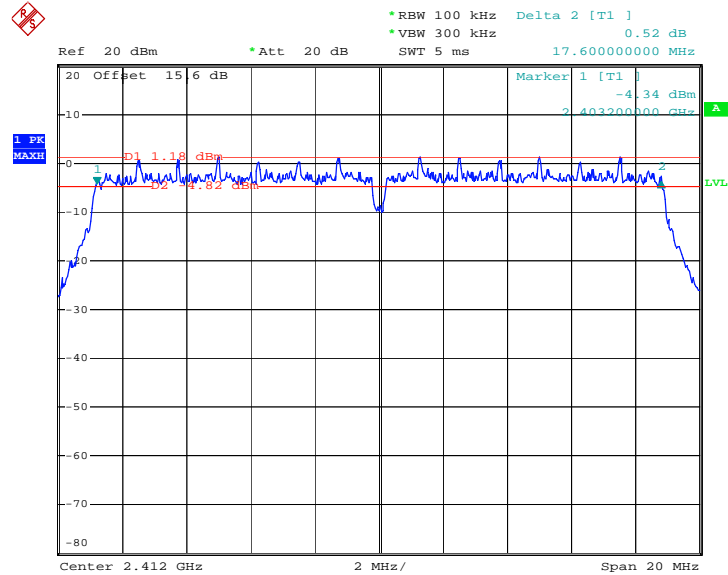

Date: 14.JUN.2013 21:15:45

6 dB Bandwidth Plot on 2.4GHz 802.11n HT20 Channel 06

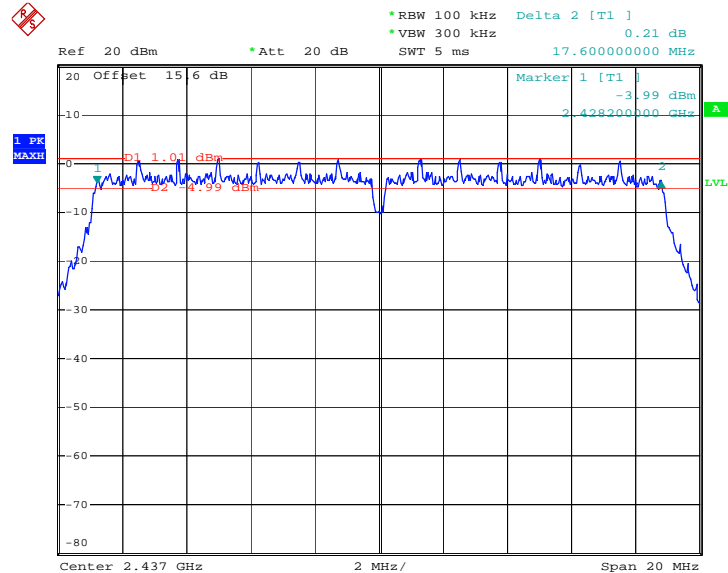

Date: 14.JUN.2013 21:18:32



6 dB Bandwidth Plot on 2.4GHz 802.11n HT20 Channel 11

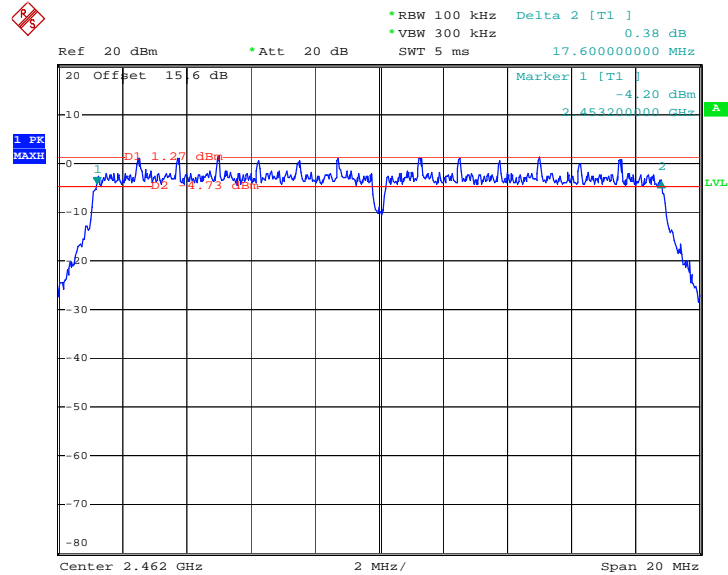

Date: 14.JUN.2013 21:21:39

6 dB Bandwidth Plot on 2.4GHz 802.11n HT40 Channel 03

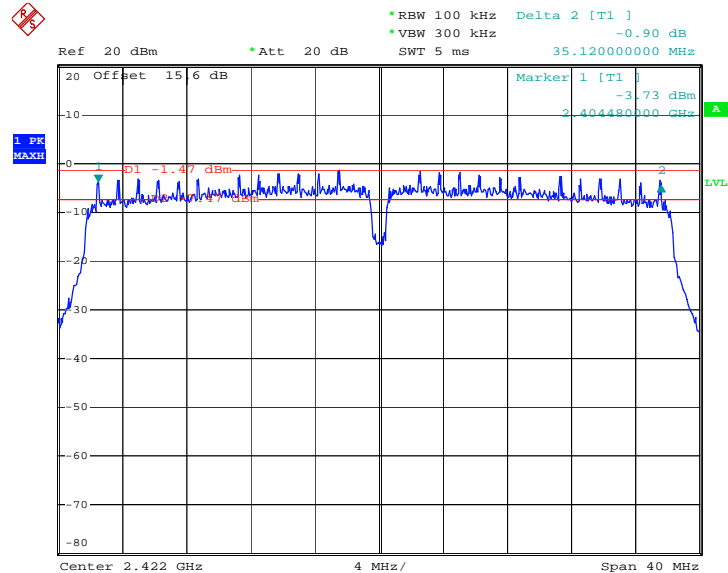

Date: 14.JUN.2013 21:25:01



6 dB Bandwidth Plot on 2.4GHz 802.11n HT40 Channel 06

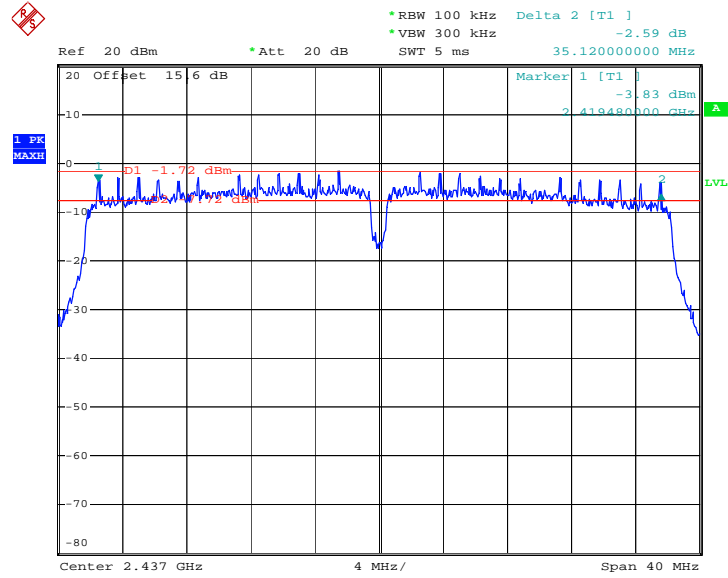

Date: 14.JUN.2013 21:30:20

6 dB Bandwidth Plot on 2.4GHz 802.11n HT40 Channel 09

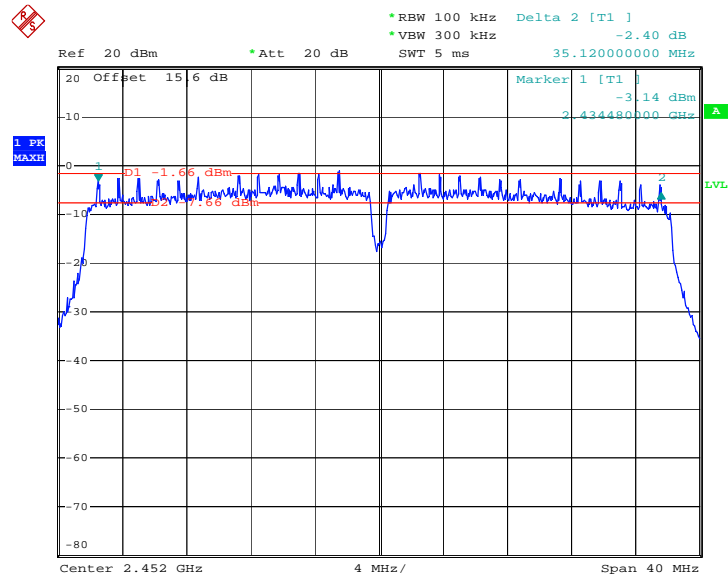

Date: 14.JUN.2013 21:32:42

3.2 Output Power Measurement

3.2.1 Limit of Output Power

For systems using digital modulation in the 2400-2483.5MHz, the limit for peak output power is 30dBm. If transmitting Antenna of directional gain greater than 6dBi are used the peak output power from the intentional radiator shall be reduced below the above stated value by the amount in dB that the directional gain of the Antenna exceeds 6 dBi. In case of point-to-point operation, the limit has to be reduced by 1dB for every 3dB that the directional gain of the Antenna exceeds 6dBi.

3.2.2 Measuring Instruments

See list of measuring instruments of this test report.

3.2.3 Test Procedures

1. The testing follows the Measurement Procedure of FCC KDB No. 558074 DTS D01 Meas. Guidance v03r01.
2. The RF output of EUT was connected to the power meter by RF cable and attenuator. The path loss was compensated to the results for each measurement.
3. Set to the maximum power setting and enable the EUT transmit continuously.
4. Measure the conducted output power and record the results in the test report.

3.2.4 Test Setup

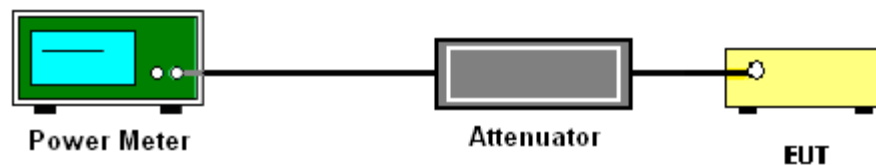

3.2.5 Test Result of Peak Output Power

Test Mode :	802.11b	Temperature :	23~24°C
Test Engineer :	Adonis Li	Relative Humidity :	47~48%

Channel	Frequency (MHz)	802.11b Peak Output Power (dBm)	Max. Limits (dBm)	Pass/Fail
01	2412	18.48	30	Pass
06	2437	18.52	30	Pass
11	2462	18.44	30	Pass

Test Mode :	802.11g	Temperature :	23~24°C
Test Engineer :	Adonis Li	Relative Humidity :	47~48%

Channel	Frequency (MHz)	802.11g Peak Output Power (dBm)	Max. Limits (dBm)	Pass/Fail
01	2412	22.39	30	Pass
06	2437	22.30	30	Pass
11	2462	22.36	30	Pass

Test Mode :	802.11n HT20	Temperature :	23~24°C
Test Engineer :	Adonis Li	Relative Humidity :	47~48%

Channel	Frequency (MHz)	2.4GHz 802.11n HT20 Peak Output Power (dBm)	Max. Limits (dBm)	Pass/Fail
01	2412	22.51	30	Pass
06	2437	22.48	30	Pass
11	2462	21.32	30	Pass

Test Mode :	802.11n HT40	Temperature :	23~24°C
Test Engineer :	Adonis Li	Relative Humidity :	47~48%

Channel	Frequency (MHz)	2.4GHz 802.11n HT40 Peak Output Power (dBm)	Max. Limits (dBm)	Pass/Fail
03	2422	20.86	30	Pass
06	2437	22.54	30	Pass
09	2452	21.02	30	Pass

3.2.6 Test Result of Average output Power (Reporting Only)

Test Mode :	802.11b	Temperature :	23~24°C
Test Engineer :	Adonis Li	Relative Humidity :	47~48%
Duty Cycle:	84.55%	Duty Factor:	0.73dB

Channel	Frequency (MHz)	802.11b Average Output Power (dBm)
01	2412	15.10
06	2437	16.07
11	2462	15.87

Test Mode :	802.11g	Temperature :	23~24°C
Test Engineer :	Adonis Li	Relative Humidity :	47~48%
Duty Cycle:	88.54%	Duty Factor:	0.53dB

Channel	Frequency (MHz)	802.11g Average Output Power (dBm)
01	2412	12.87
06	2437	14.00
11	2462	14.15

Test Mode :	802.11n HT20	Temperature :	23~24°C
Test Engineer :	Adonis Li	Relative Humidity :	47~48%
Duty Cycle:	88.21%	Duty Factor:	0.54dB

Channel	Frequency (MHz)	2.4GHz 802.11n HT20 Average Output Power (dBm)
01	2412	13.01
06	2437	12.81
11	2462	11.87

Test Mode :	802.11n HT40	Temperature :	23~24°C
Test Engineer :	Adonis Li	Relative Humidity :	47~48%
Duty Cycle:	79.13%	Duty Factor:	1.02dB

Channel	Frequency (MHz)	2.4GHz 802.11n HT40 Average Output Power (dBm)
03	2422	9.98
06	2437	13.62
09	2452	10.88

3.3 Power Spectral Density Measurement

3.3.1 Limit of Power Spectral Density

The peak power spectral density shall not be greater than 8dBm in any 3kHz band at any time interval of continuous transmission.

3.3.2 Measuring Instruments

See list of measuring instruments of this test report.

3.3.3 Test Procedures

1. The testing follows Measurement Procedure 10.2 Method PKPSD of FCC KDB Publication No. 558074 D01 DTS Meas. Guidance v03r01
2. The RF output of EUT was connected to the spectrum analyzer by RF cable and attenuator. The path loss was compensated to the results for each measurement.
3. Set to the maximum power setting and enable the EUT transmit continuously.
4. Make the measurement with the spectrum analyzer's resolution bandwidth (RBW) = 3 kHz. Video bandwidth VBW = 10 kHz In order to make an accurate measurement, set the span to 1.5 times DTS Channel Bandwidth. (6dB BW)
5. Detector = peak, Sweep time = auto couple, Trace mode = max hold, Allow trace to fully stabilize. Use the peak marker function to determine the maximum power level.
6. Measure and record the results in the test report.
7. The Measured power density (dBm)/ 100kHz is a reference level and used as 20dBc down limit line for Conducted Band Edges and Conducted Spurious Emission.

3.3.4 Test Setup

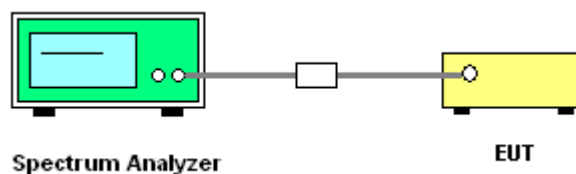

3.3.5 Test Result of Power Spectral Density

Test Mode :	802.11b	Temperature :	23~24°C
Test Engineer :	Adonis Li	Relative Humidity :	47~48%

Channel	Frequency (MHz)	802.11b Power Density		Max. Limits (dBm/3kHz)	Pass/Fail
		PSD/100kHz (dBm)	PSD/3kHz (dBm)		
01	2412	6.72	-7.65	8	Pass
06	2437	6.87	-6.47	8	Pass
11	2462	6.41	-7.29	8	Pass

Test Mode :	802.11g	Temperature :	23~24°C
Test Engineer :	Adonis Li	Relative Humidity :	47~48%

Channel	Frequency (MHz)	802.11g Power Density		Max. Limits (dBm/3kHz)	Pass/Fail
		PSD/100kHz (dBm)	PSD/3kHz (dBm)		
01	2412	2.70	-10.97	8	Pass
06	2437	3.07	-10.27	8	Pass
11	2462	3.31	-11.07	8	Pass



Test Mode :	802.11n HT20	Temperature :	23~24°C
Test Engineer :	Adonis Li	Relative Humidity :	47~48%

Channel	Frequency (MHz)	2.4GHz 802.11n HT20 Power Density		Max. Limits (dBm/3kHz)	Pass/Fail
		PSD/100kHz (dBm)	PSD/3kHz (dBm)		
01	2412	1.14	-12.87	8	Pass
06	2437	0.96	-13.02	8	Pass
11	2462	1.06	-13.08	8	Pass

Test Mode :	802.11n HT40	Temperature :	23~24°C
Test Engineer :	Adonis Li	Relative Humidity :	47~48%

Channel	Frequency (MHz)	2.4GHz 802.11n HT40 Power Density		Max. Limits (dBm/3kHz)	Pass/Fail
		PSD/100kHz (dBm)	PSD/3kHz (dBm)		
03	2422	-1.51	-15.87	8	Pass
06	2437	-2.04	-16.37	8	Pass
09	2452	-1.20	-15.84	8	Pass

Note:

1. Measured power density (dBm) has offset with cable loss.
2. The Measured power density (dBm)/ 100kHz is reference level and used as 20dBc down for Conducted Band Edges and Conducted Spurious Emission limit line.



3.3.6 Test Result of Power Spectral Density Plots (100kHz)

PSD 100kHz Plot on 802.11b Channel 01

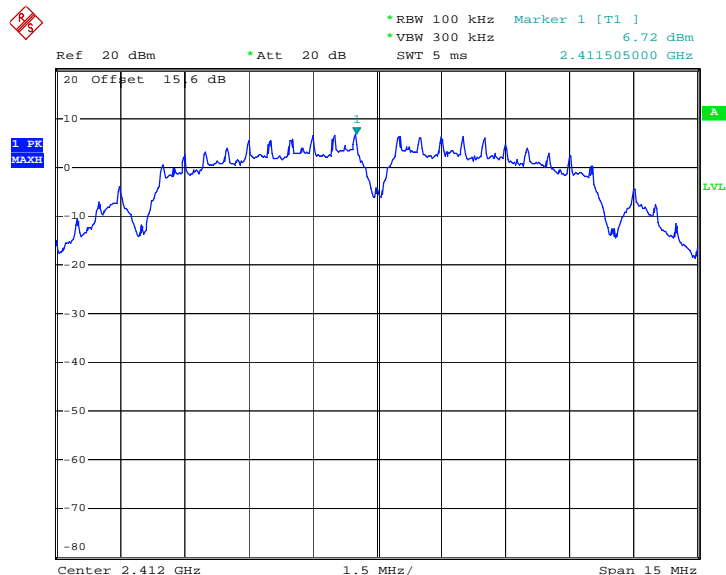

Date: 14.JUN.2013 19:38:24

PSD 100kHz Plot on 802.11b Channel 06

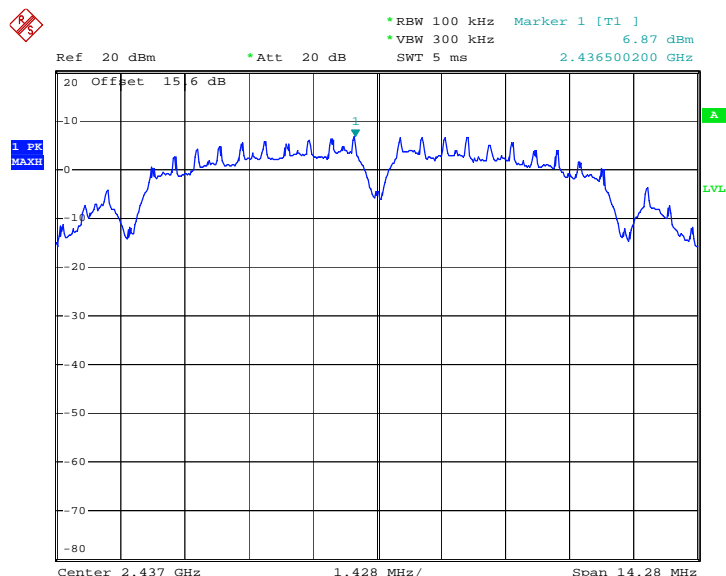

Date: 15.JUN.2013 18:34:13



PSD 100kHz Plot on 802.11b Channel 11

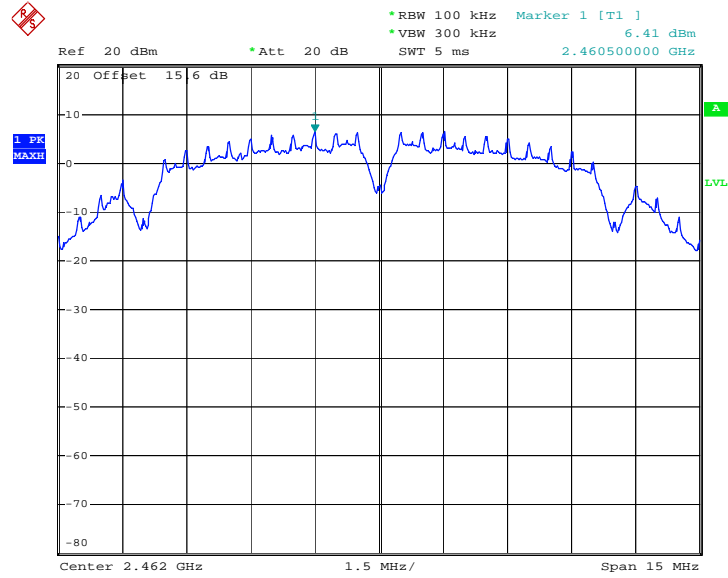

Date: 14.JUN.2013 19:54:08

PSD 100kHz Plot on 802.11g Channel 01

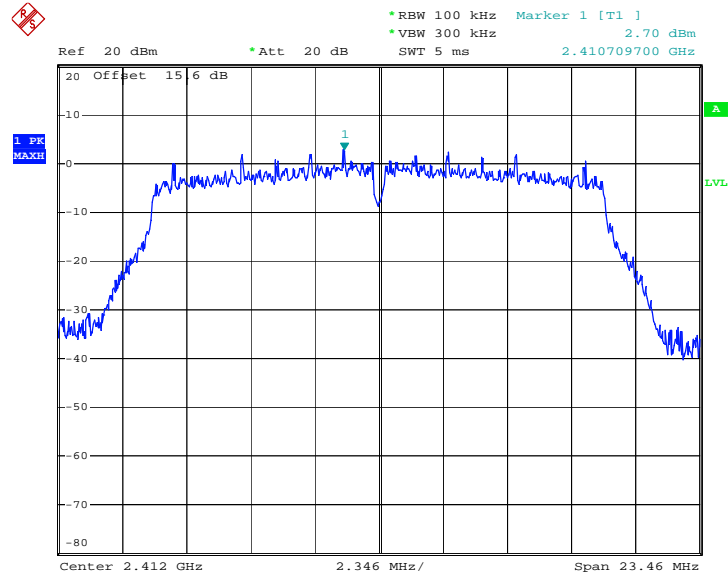

Date: 14.JUN.2013 20:54:07



PSD 100kHz Plot on 802.11g Channel 06

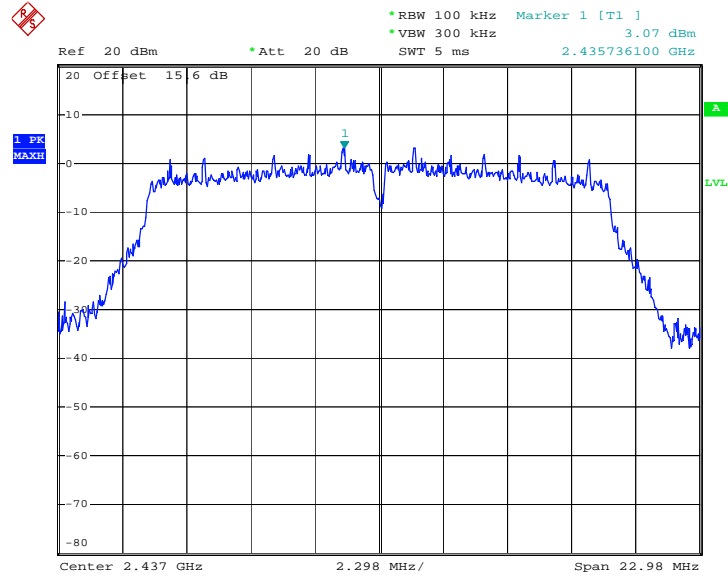

Date: 14.JUN.2013 21:08:53

PSD 100kHz Plot on 802.11g Channel 11

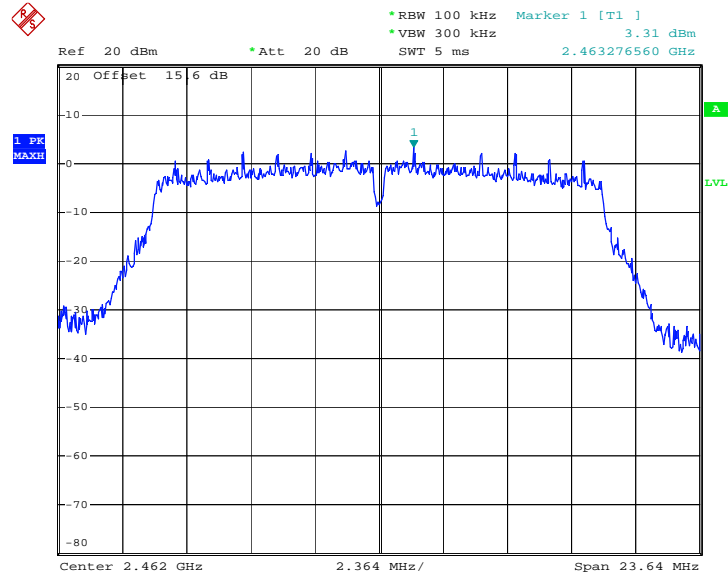

Date: 14.JUN.2013 21:11:22



PSD 100kHz Plot on 2.4GHz 802.11n HT20 Channel 01

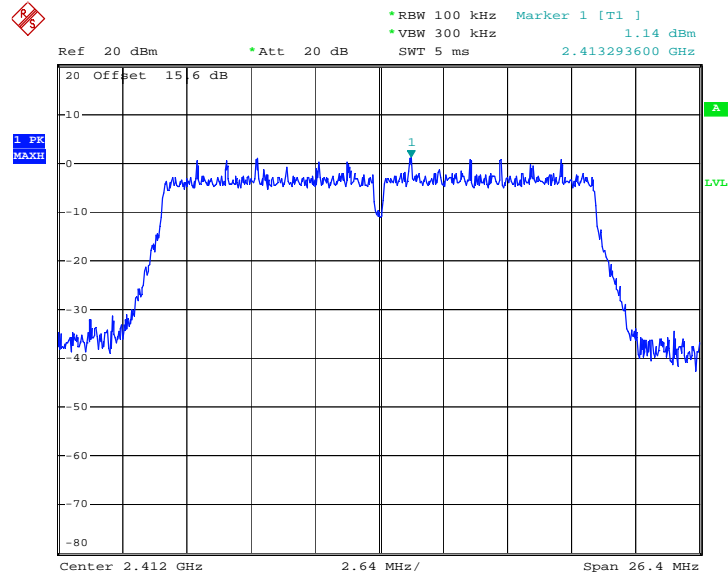

Date: 14.JUN.2013 21:16:18

PSD 100kHz Plot on 2.4GHz 802.11n HT20 Channel 06

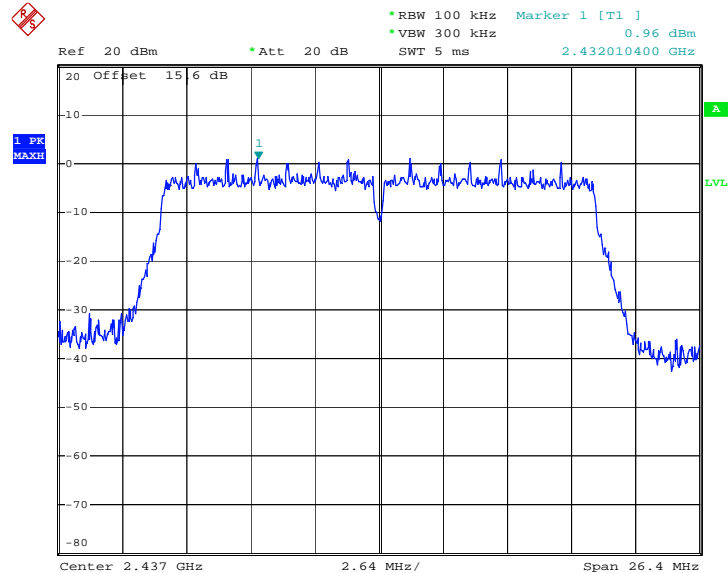

Date: 14.JUN.2013 21:19:05



PSD 100kHz Plot on 2.4GHz 802.11n HT20 Channel 11

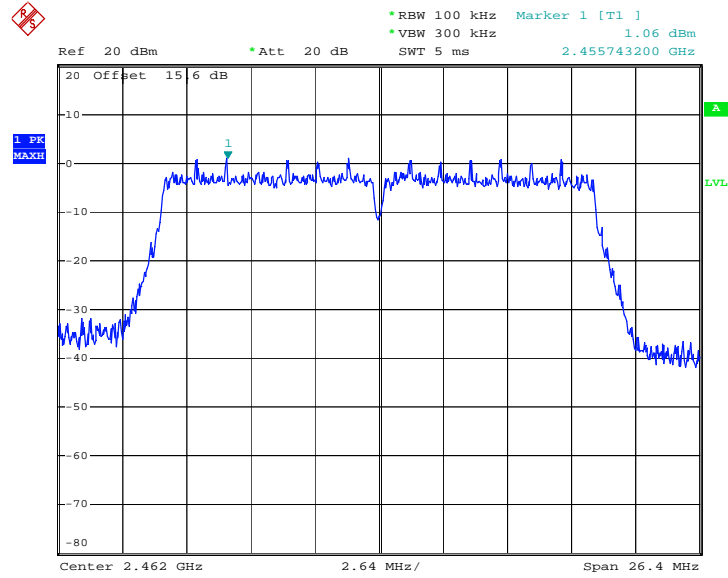

Date: 14.JUN.2013 21:22:12

PSD 100kHz Plot on 2.4GHz 802.11n HT40 Channel 03

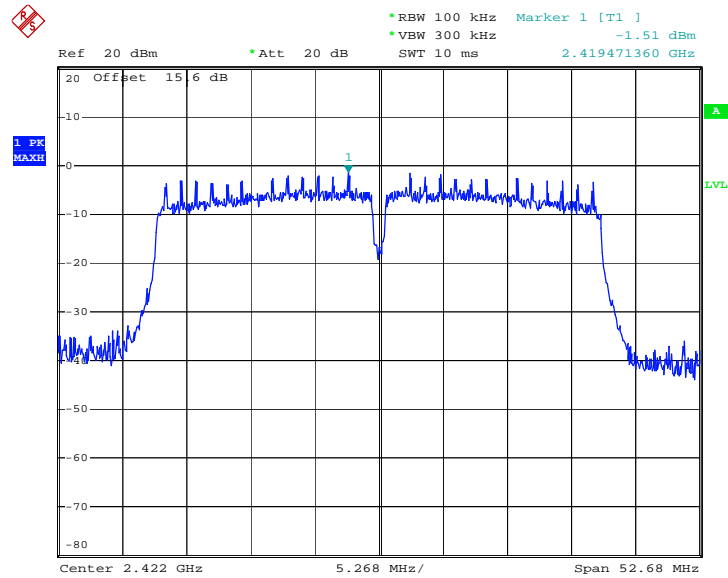

Date: 14.JUN.2013 21:25:38



PSD 100kHz Plot on 2.4GHz 802.11n HT40 Channel 06

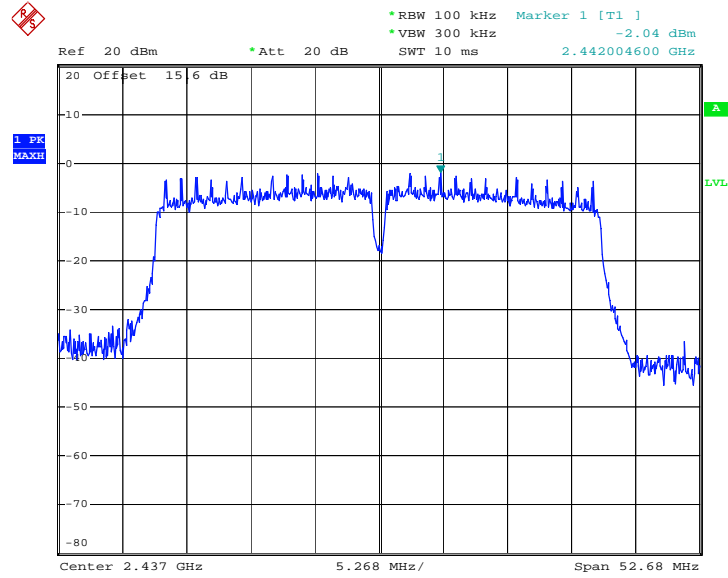

Date: 14.JUN.2013 21:30:56

PSD 100kHz Plot on 2.4GHz 802.11n HT40 Channel 09

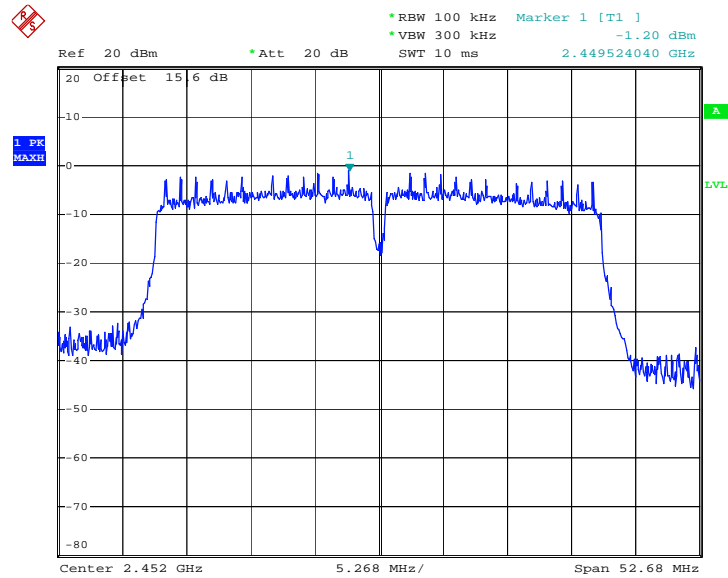

Date: 14.JUN.2013 21:33:18



3.3.7 Test Result of Power Spectral Density Plots (3kHz)

PSD 3kHz Plot on 802.11b Channel 01

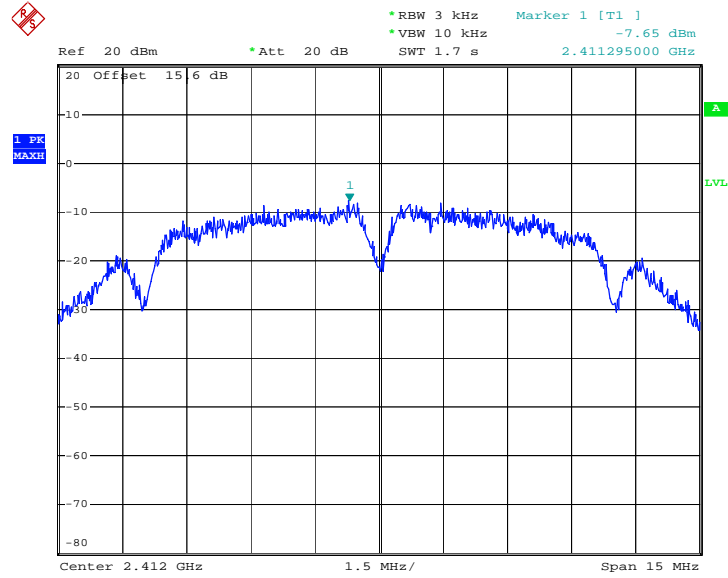

Date: 14.JUN.2013 19:38:14

PSD 3kHz Plot on 802.11b Channel 06

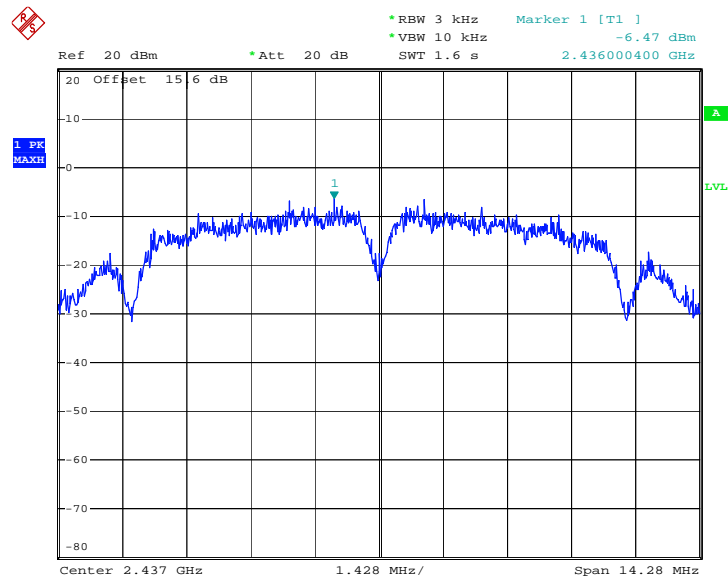

Date: 15.JUN.2013 18:34:03



PSD 3kHz Plot on 802.11b Channel 11

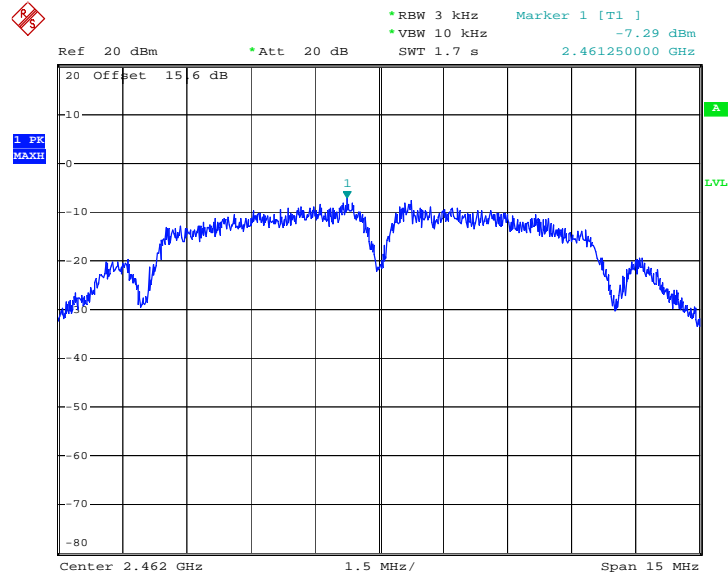

Date: 14.JUN.2013 19:53:58

PSD 3kHz Plot on 802.11g Channel 01

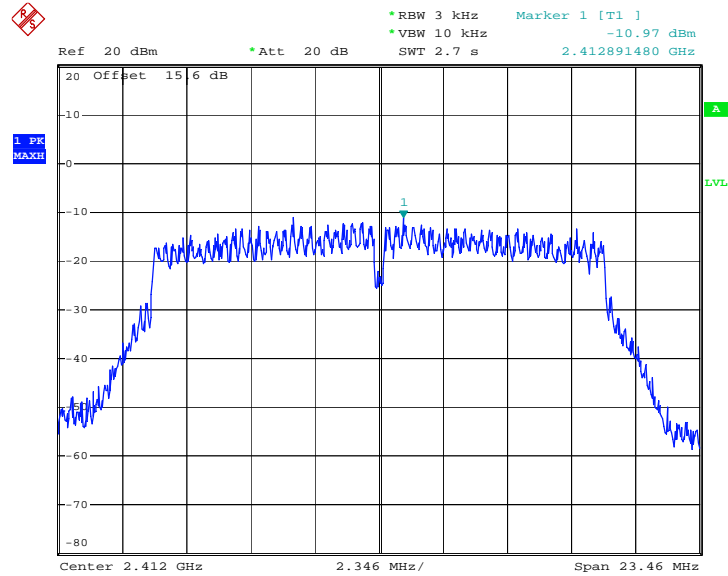

Date: 14.JUN.2013 20:53:57



PSD 3kHz Plot on 802.11g Channel 06

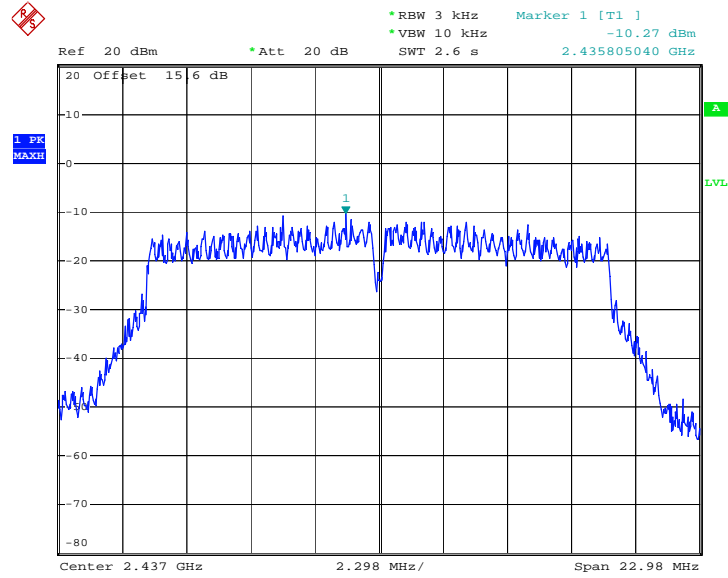

Date: 14.JUN.2013 21:08:43

PSD 3kHz Plot on 802.11g Channel 11

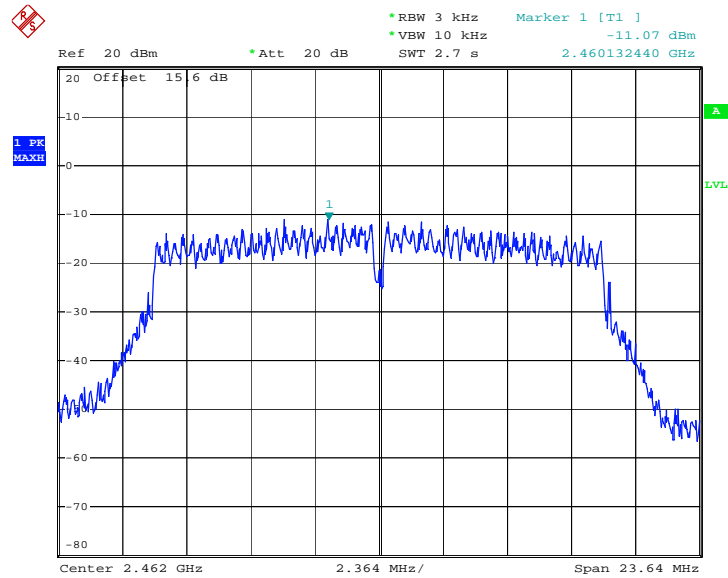

Date: 14.JUN.2013 21:11:12



PSD 3kHz Plot on 2.4GHz 802.11n HT20 Channel 01

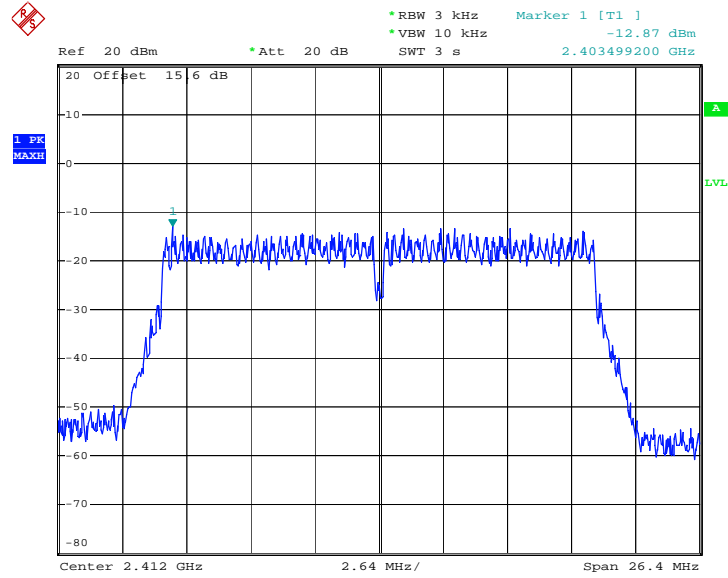

Date: 14.JUN.2013 21:16:08

PSD 3kHz Plot on 2.4GHz 802.11n HT20 Channel 06

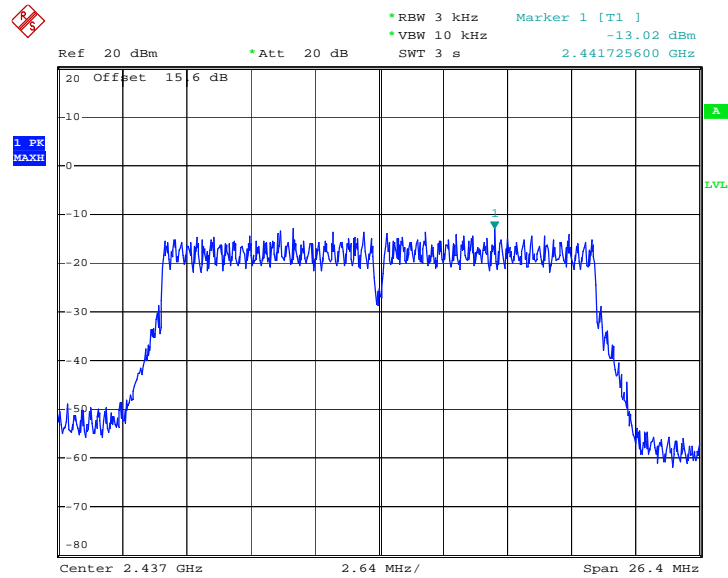

Date: 14.JUN.2013 21:18:55



PSD 3kHz Plot on 2.4GHz 802.11n HT20 Channel 11

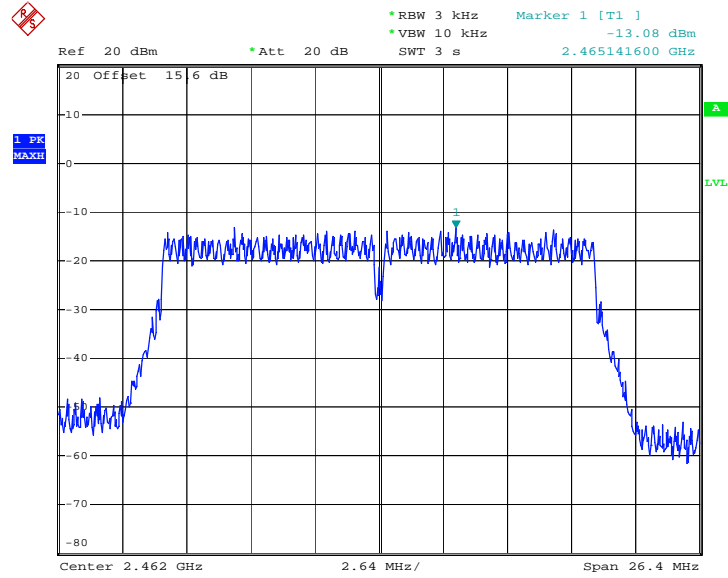

Date: 14.JUN.2013 21:22:02

PSD 3kHz Plot on 2.4GHz 802.11n HT40 Channel 03

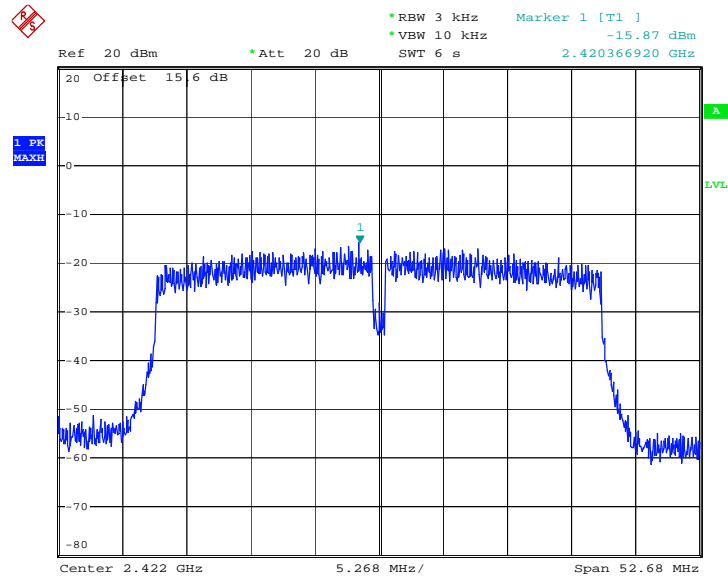

Date: 14.JUN.2013 21:25:28



PSD 3kHz Plot on 2.4GHz 802.11n HT40 Channel 06

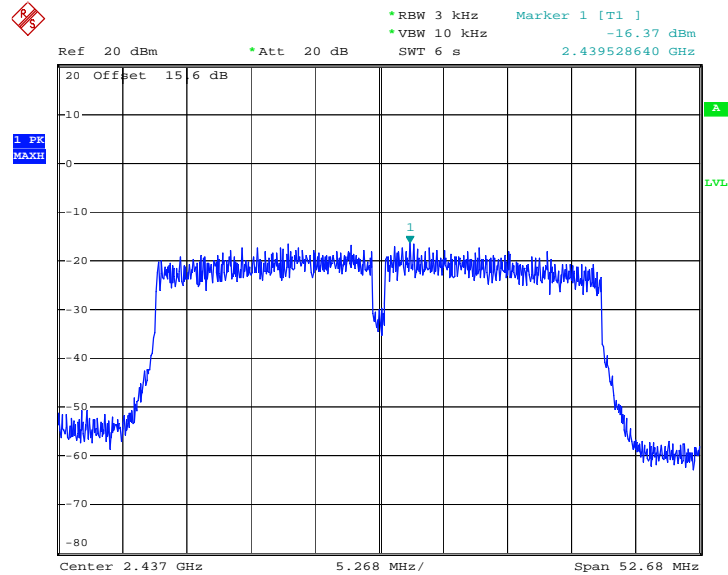

Date: 14.JUN.2013 21:30:46

PSD 3kHz Plot on 2.4GHz 802.11n HT40 Channel 09

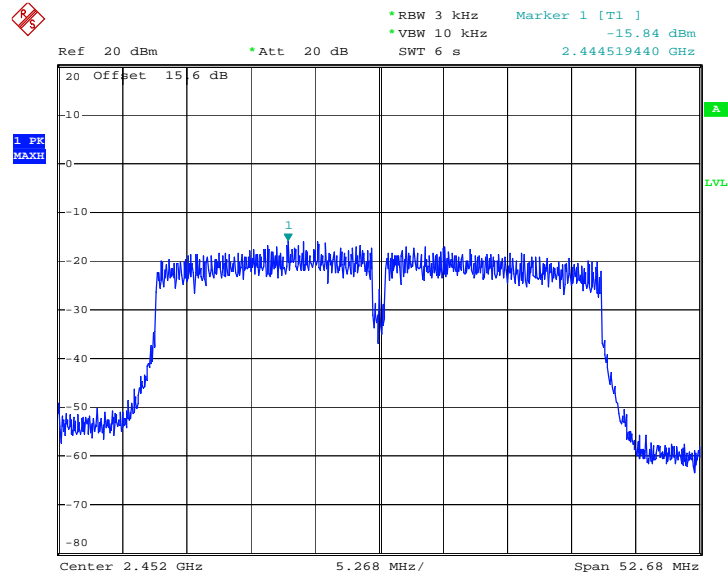

Date: 14.JUN.2013 21:33:08

3.4 Conducted Band Edges and Spurious Emission Measurement

3.4.1 Limit of Conducted Band Edges and Spurious Emission Measurement

In any 100 kHz bandwidth outside of the authorized frequency band, the emissions which fall in the non-restricted bands shall be attenuated at least 20 dB / 30dB relative to the maximum PSD level in 100 kHz by RF conducted measurement and radiated emissions which fall in the restricted bands, as defined in Section 15.205(a), must also comply with the radiated emission limits specified in Section 15.209(a).

3.4.2 Measuring Instruments

See list of measuring instruments of this test report.

3.4.3 Test Procedures

1. The testing follows FCC KDB Publication No. 558074 D01 DTS Meas. Guidance v03r01.
2. The RF output of EUT was connected to the spectrum analyzer by RF cable and attenuator. The path loss was compensated to the results for each measurement.
3. Set to the maximum power setting and enable the EUT transmit continuously.
4. If the transmitter complies with the conducted power limits based on the use of RMS averaging over a time interval.
5. Set RBW = 100 kHz, VBW=300 kHz, Peak Detector. Unwanted Emissions measured in any 100 kHz bandwidth outside of the authorized frequency band shall be attenuated by at least 20 dB relative to the maximum in-band peak PSD level in 100 kHz when maximum peak conducted output power procedure is used. If the transmitter complies with the conducted power limits based on the use of RMS averaging over a time interval, the attenuation required under this paragraph shall be 30 dB instead of 20 dB per 15.247(d).
6. The RF fundamental frequency should be excluded against the limit line in the operating frequency band.
7. Measure and record the results in the test report.

3.4.4 Test Setup

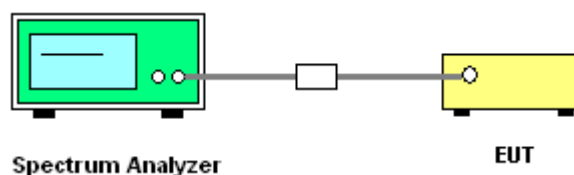

2.4.5 Test Result of Conducted Spurious at Band Edges

Test Mode :	802.11b	Temperature :	23~24°C
Test Band :	Low and High	Relative Humidity :	47~48%
Test Channel :	01 and 11	Test Engineer :	Adonis Li

Low Band Edge Plot on 802.11b Channel 01

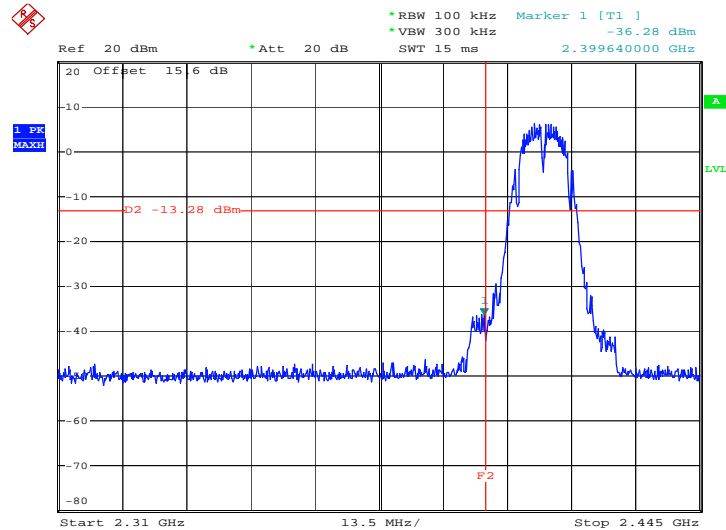

Date: 14.JUN.2013 19:38:39

High Band Edge Plot on 802.11b Channel 11

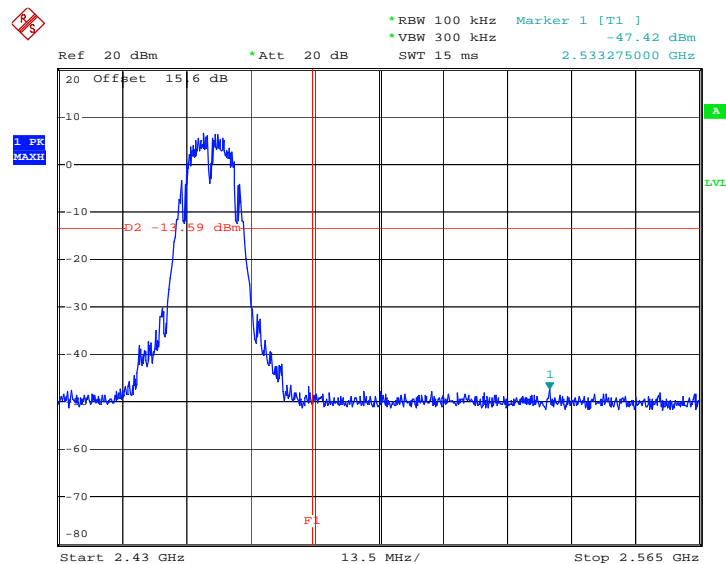

Date: 14.JUN.2013 19:54:23



Test Mode :	802.11g	Temperature :	23~24°C
Test Band :	Low and High	Relative Humidity :	47~48%
Test Channel :	01 and 11	Test Engineer :	Adonis Li

Low Band Edge Plot on 802.11g Channel 01

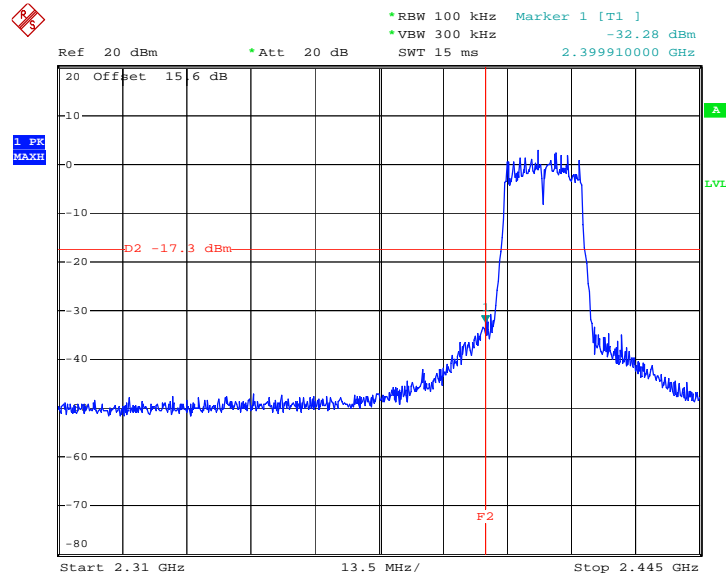

Date: 14.JUN.2013 20:54:22

High Band Edge Plot on 802.11g Channel 11

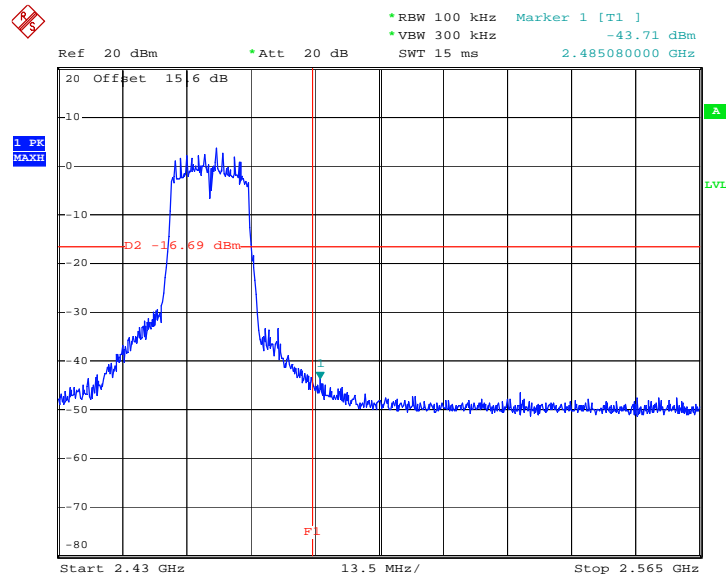

Date: 14.JUN.2013 21:11:37



Test Mode :	802.11n HT20	Temperature :	23~24°C
Test Band :	Low and High	Relative Humidity :	47~48%
Test Channel :	01 and 11	Test Engineer :	Adonis Li

Low Band Edge Plot on 2.4GHz 802.11n HT20 Channel 01

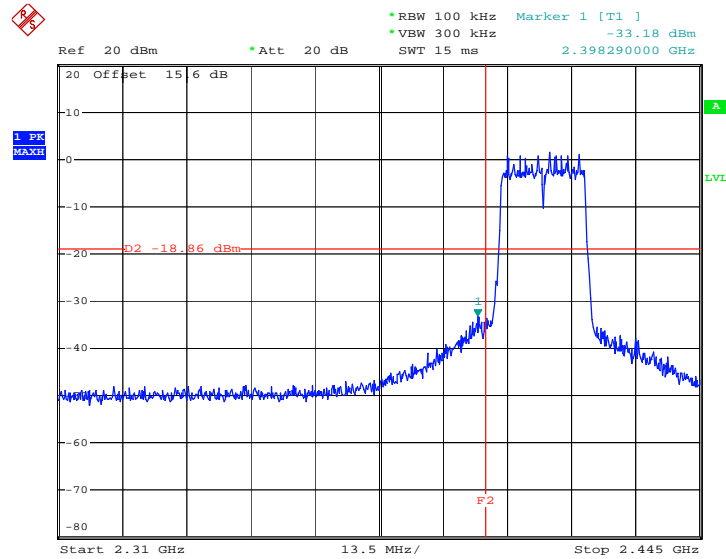

Date: 14.JUN.2013 21:16:33

High Band Edge Plot on 2.4GHz 802.11n HT20 Channel 11

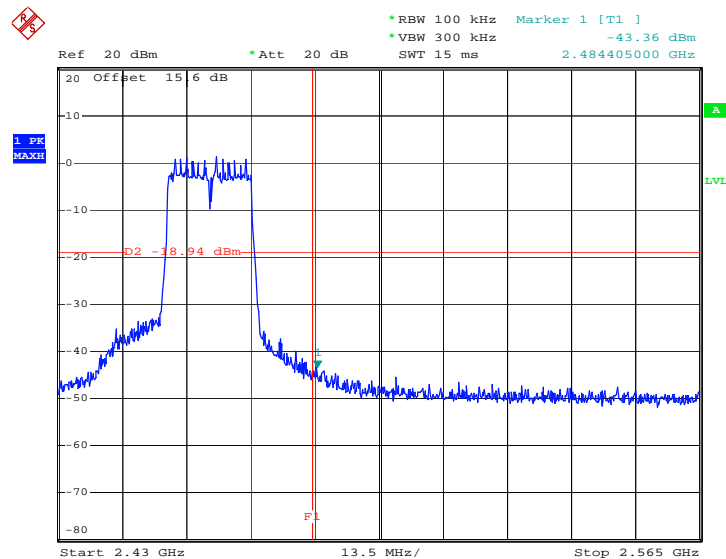

Date: 14.JUN.2013 21:22:27



Test Mode :	802.11n HT40	Temperature :	23~24°C
Test Band :	Low and High	Relative Humidity :	47~48%
Test Channel :	03 and 09	Test Engineer :	Adonis Li

Low Band Edge Plot on 2.4GHz 802.11n HT40 Channel 03

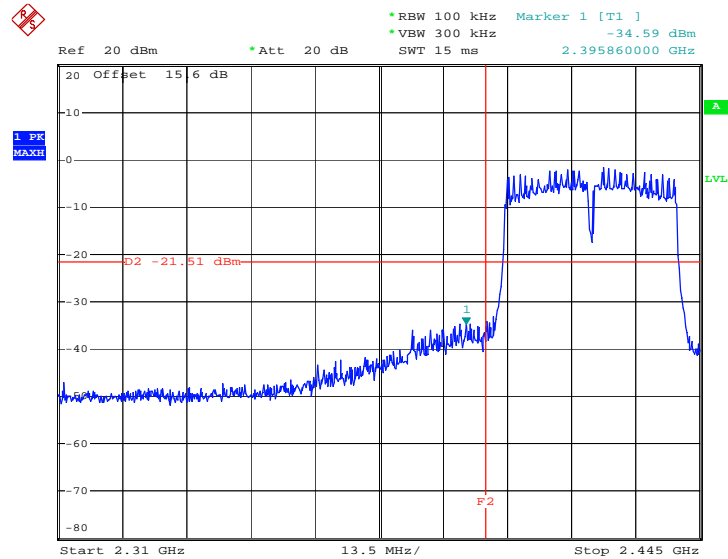

Date: 14.JUN.2013 21:25:53

High Band Edge Plot on 2.4GHz 802.11n HT40 Channel 09

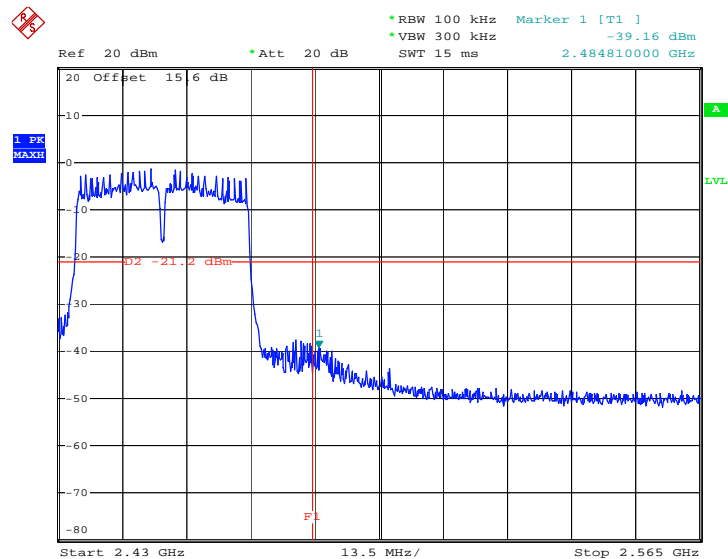

Date: 14.JUN.2013 21:33:33

3.4.5 Test Result of Conducted Spurious Emission

Test Mode :	802.11b	Temperature :	23~24°C
Test Band :	30MHz-3GHz and 2G-25GHz	Relative Humidity :	47~48%
Test Channel :	01, 06, 11	Test Engineer :	Adonis Li

802.11b 30 MHz~3 GHz

Conducted Spurious Emission Plot on Channel 01

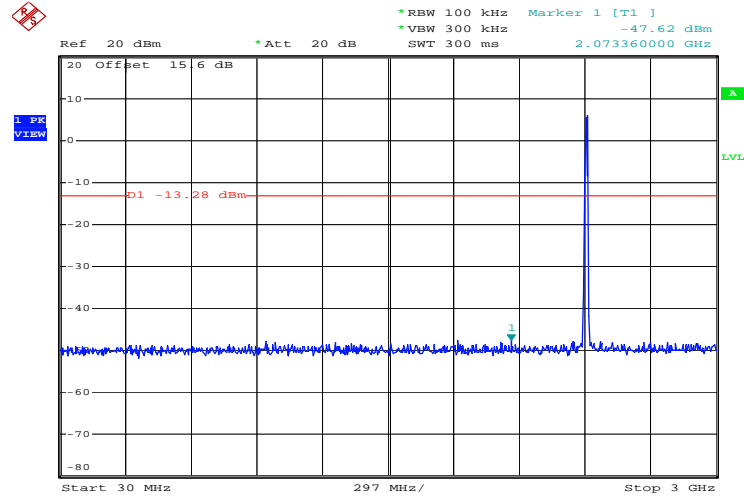

Date: 14.JUN.2013 19:38:59

802.11b 2 GHz~25 GHz

Conducted Spurious Emission Plot on Channel 01

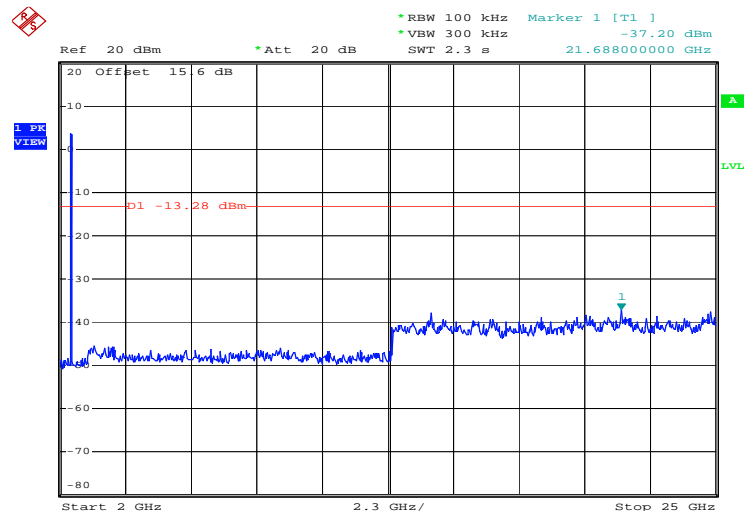

Date: 14.JUN.2013 19:39:18



802.11b 30 MHz~3 GHz

Conducted Spurious Emission Plot on Channel 06

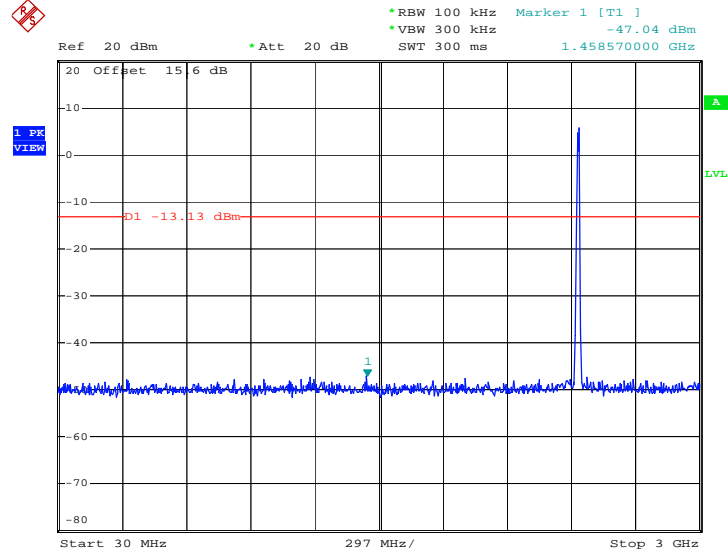

Date: 15.JUN.2013 18:34:33

802.11b 2 GHz~25 GHz

Conducted Spurious Emission Plot on Channel 06

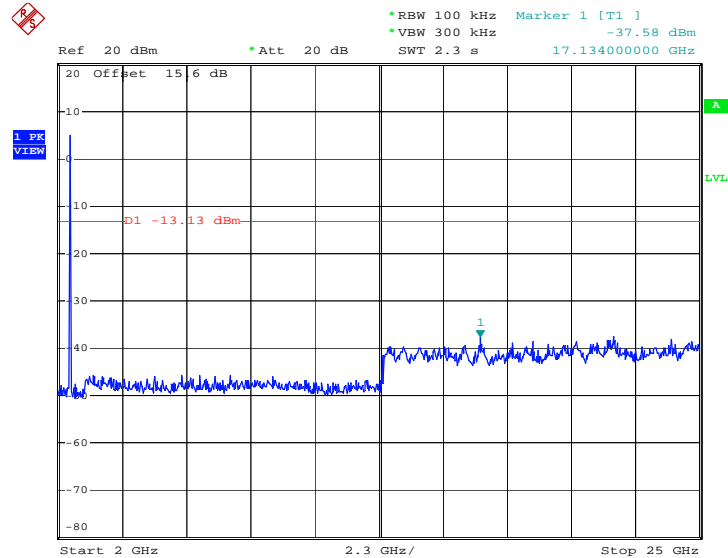

Date: 15.JUN.2013 18:34:53



802.11b 30 MHz~3 GHz

Conducted Spurious Emission Plot on Channel 11

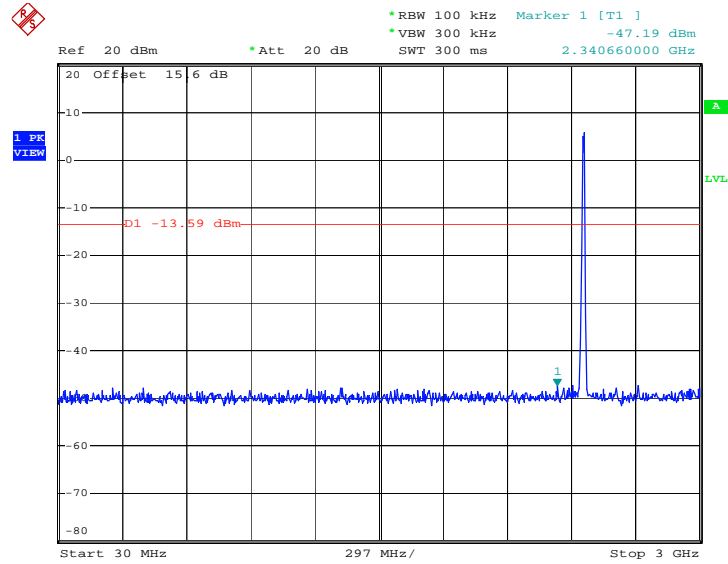

Date: 14.JUN.2013 19:54:43

802.11b 2 GHz~25 GHz

Conducted Spurious Emission Plot on Channel 11

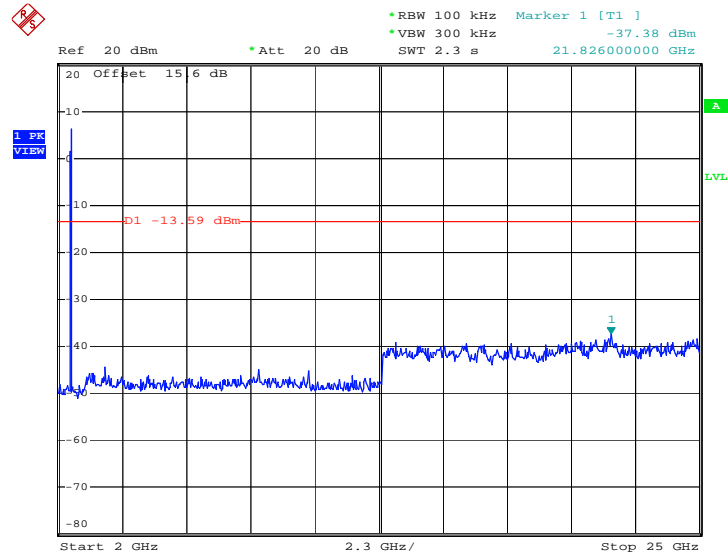

Date: 14.JUN.2013 19:55:03



Test Mode :	802.11g	Temperature :	23~24°C
Test Band :	30MHz-3GHz and 2G-25GHz	Relative Humidity :	47~48%
Test Channel :	01, 06, 11	Test Engineer :	Adonis Li

802.11g 30 MHz~3 GHz

Conducted Spurious Emission Plot on Channel 01

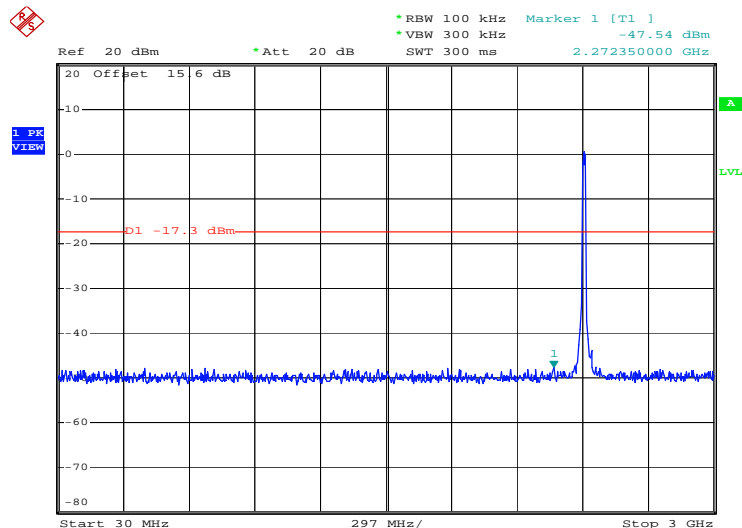

Date: 14.JUN.2013 20:54:42

802.11g 2 GHz~25 GHz

Conducted Spurious Emission Plot on Channel 01

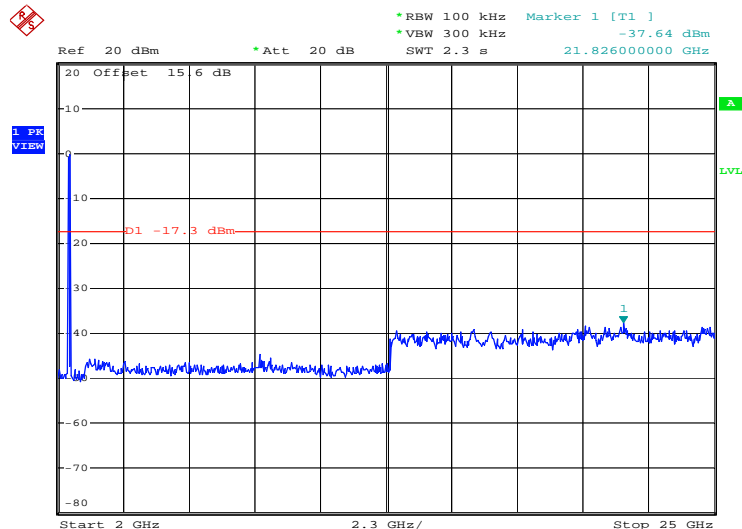

Date: 14.JUN.2013 20:55:02

802.11g 30 MHz~3 GHz

Conducted Spurious Emission Plot on Channel 06

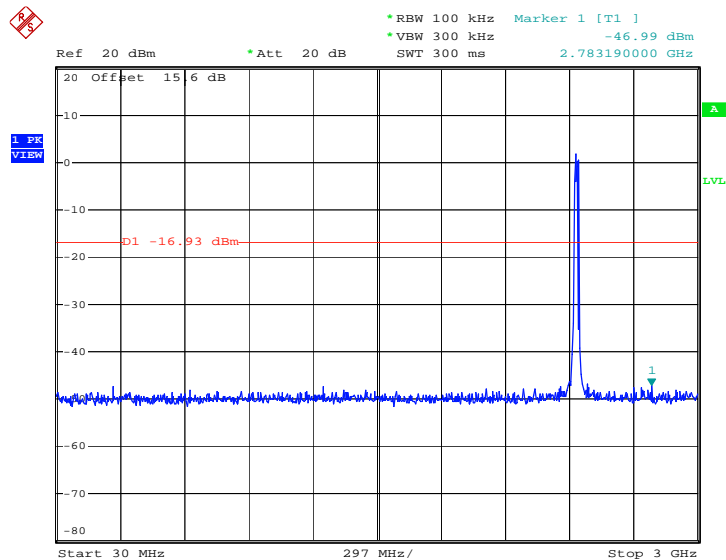

Date: 14.JUN.2013 21:09:13

802.11g 2 GHz~25 GHz

Conducted Spurious Emission Plot on Channel 06

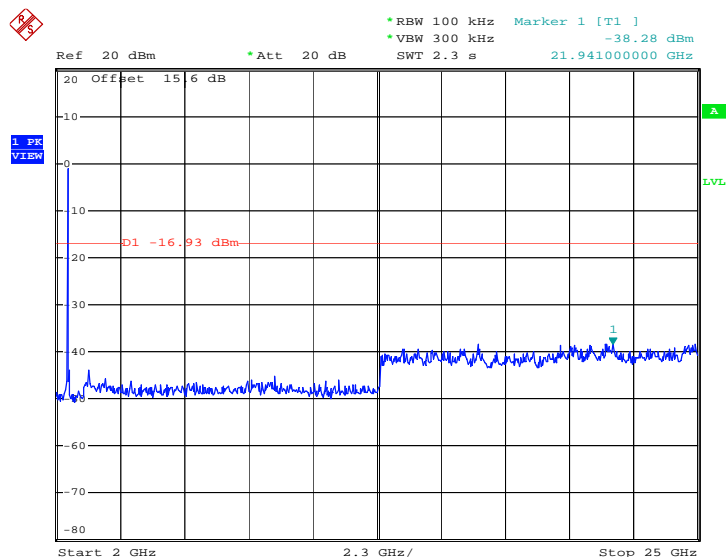

Date: 14.JUN.2013 21:09:33



802.11g 30 MHz~3 GHz

Conducted Spurious Emission Plot on Channel 11

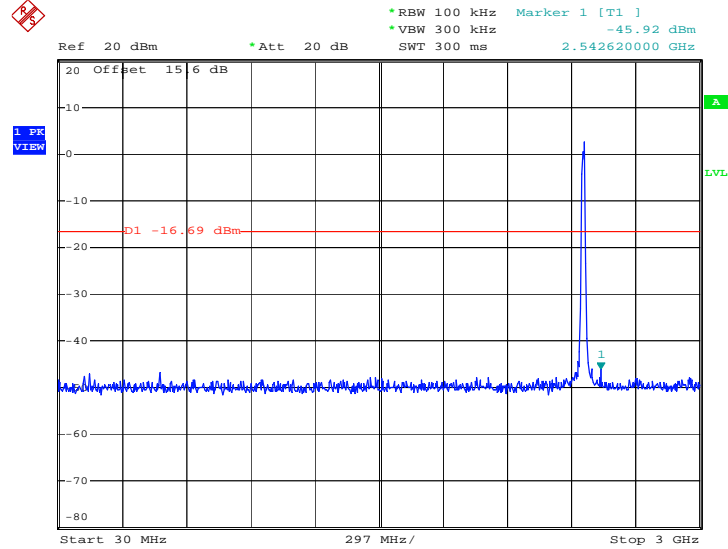

Date: 14.JUN.2013 21:11:57

802.11g 2 GHz~25 GHz

Conducted Spurious Emission Plot on Channel 11

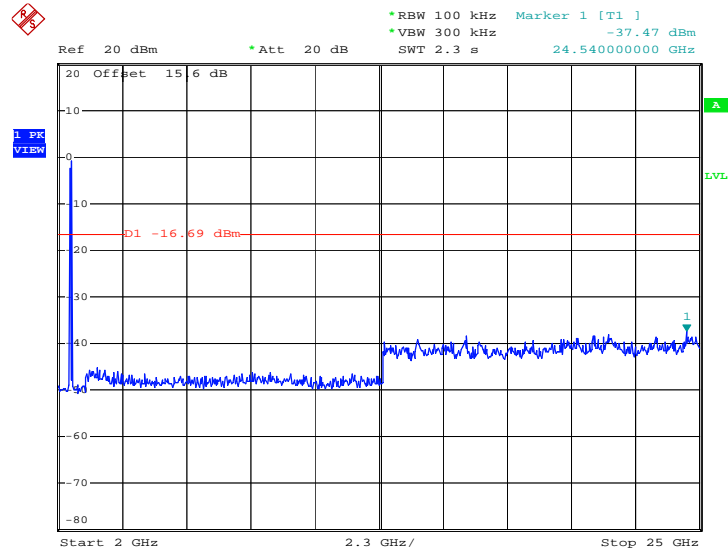

Date: 14.JUN.2013 21:12:17



Test Mode :	802.11n HT20	Temperature :	23~24°C
Test Band :	30MHz-3GHz and 2G-25GHz	Relative Humidity :	47~48%
Test Channel :	01, 06, 11	Test Engineer :	Adonis Li

2.4GHz 802.11n HT20 30 MHz~3 GHz

Conducted Spurious Emission Plot on Channel 01

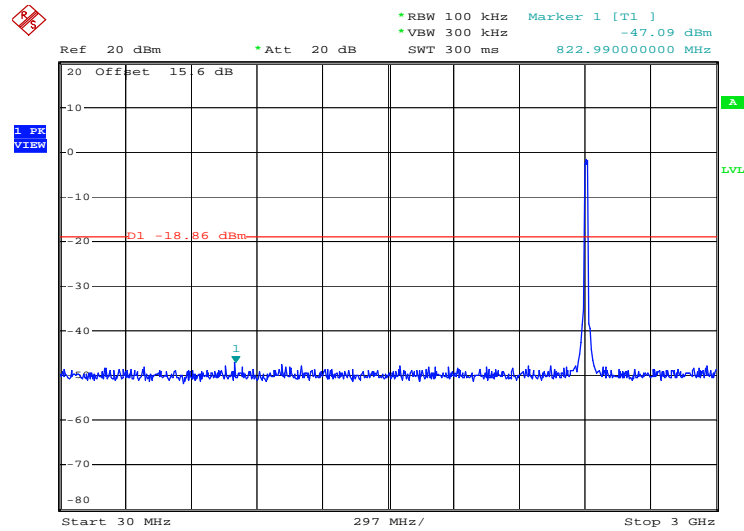

Date: 14.JUN.2013 21:16:54

2.4GHz 802.11n HT20 2 GHz~25 GHz

Conducted Spurious Emission Plot on Channel 01

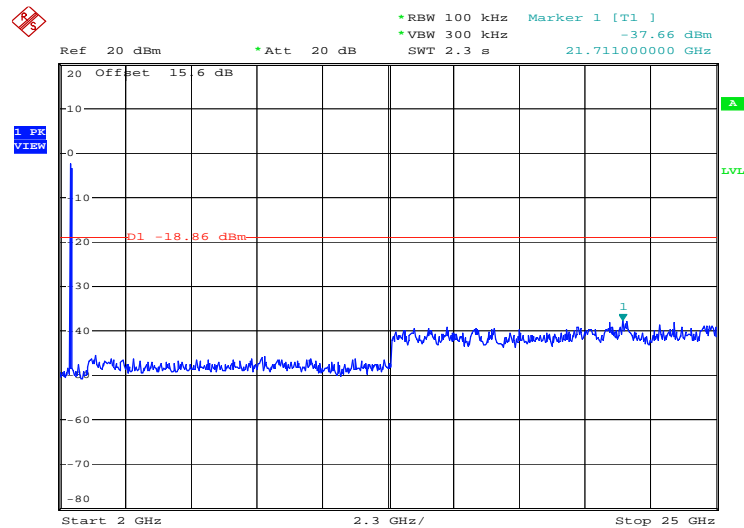

Date: 14.JUN.2013 21:17:13



2.4GHz 802.11n HT20 30 MHz~3 GHz

Conducted Spurious Emission Plot on Channel 06

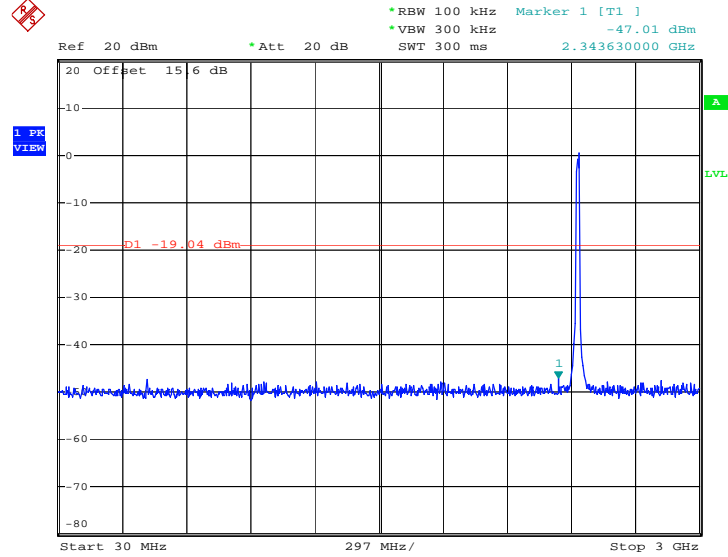

Date: 14.JUN.2013 21:19:26

2.4GHz 802.11n HT20 2 GHz~25 GHz

Conducted Spurious Emission Plot on Channel 06

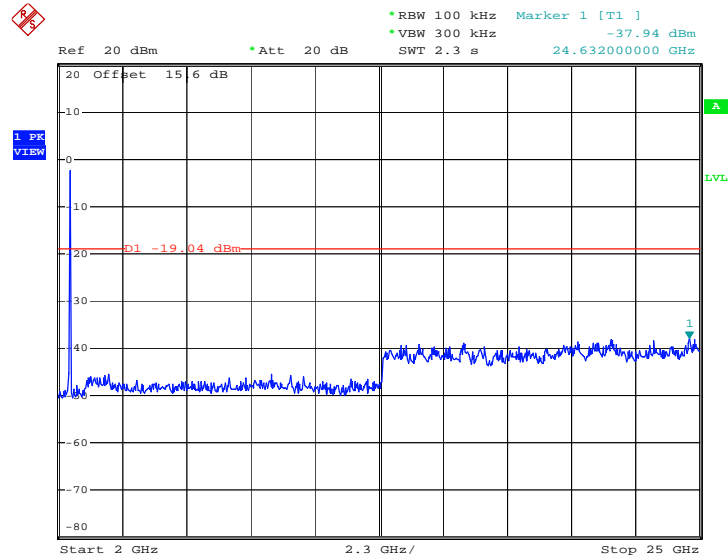

Date: 14.JUN.2013 21:19:45



2.4GHz 802.11n HT20 30 MHz~3 GHz

Conducted Spurious Emission Plot on Channel 11

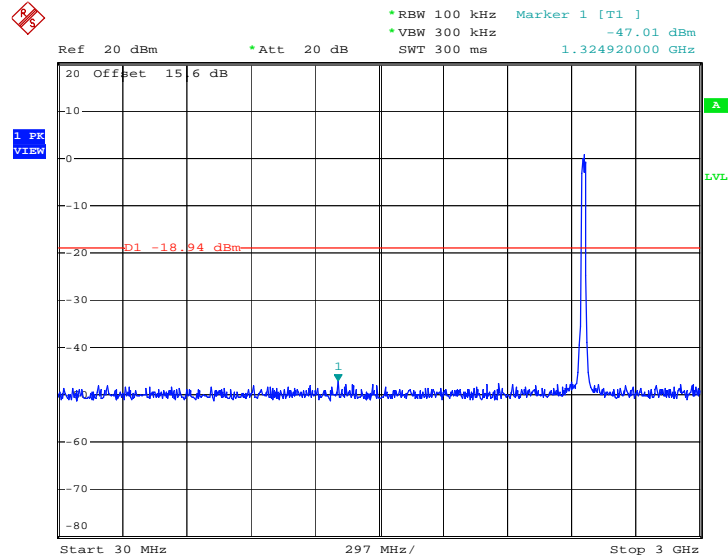

Date: 14.JUN.2013 21:22:47

2.4GHz 802.11n HT20 2 GHz~25 GHz

Conducted Spurious Emission Plot on Channel 11

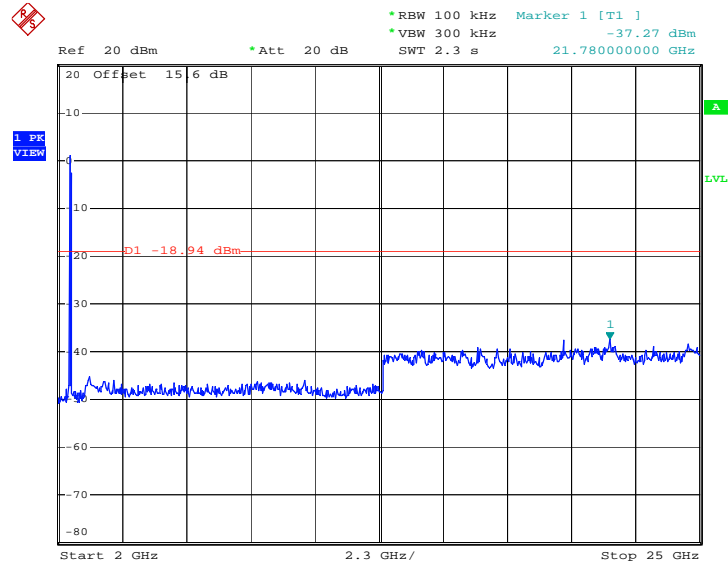

Date: 14.JUN.2013 21:23:07



Test Mode :	802.11n HT40	Temperature :	23~24°C
Test Band :	30MHz-3GHz and 2G-25GHz	Relative Humidity :	47~48%
Test Channel :	03, 06, 09	Test Engineer :	Adonis Li

2.4GHz 802.11n HT40 30 MHz~3 GHz

Conducted Spurious Emission Plot on Channel 03

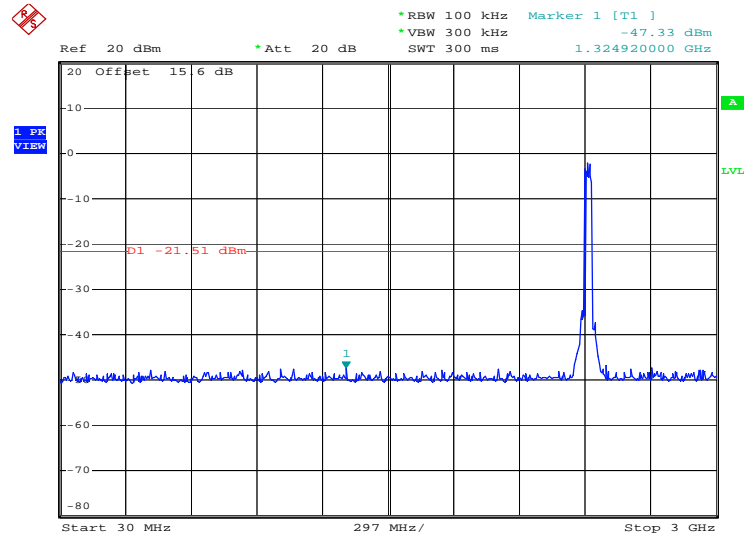

Date: 14.JUN.2013 21:28:43

2.4GHz 802.11n HT40 2 GHz~25 GHz

Conducted Spurious Emission Plot on Channel 03

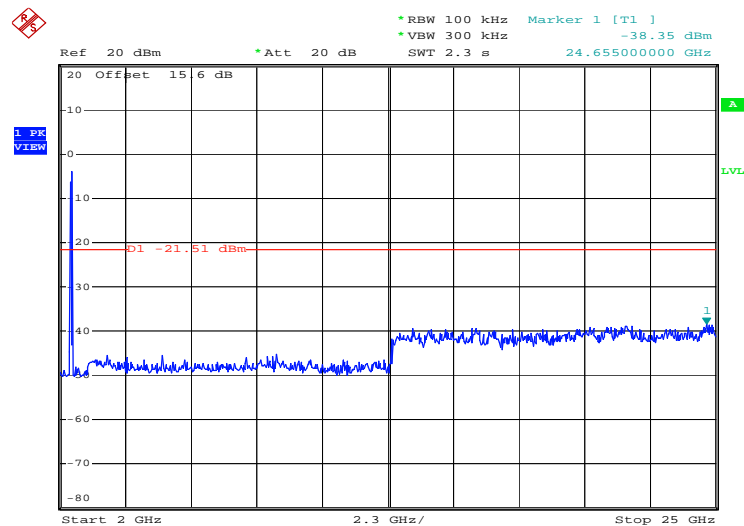

Date: 14.JUN.2013 21:26:33



2.4GHz 802.11n HT40 30 MHz~3 GHz

Conducted Spurious Emission Plot on Channel 06

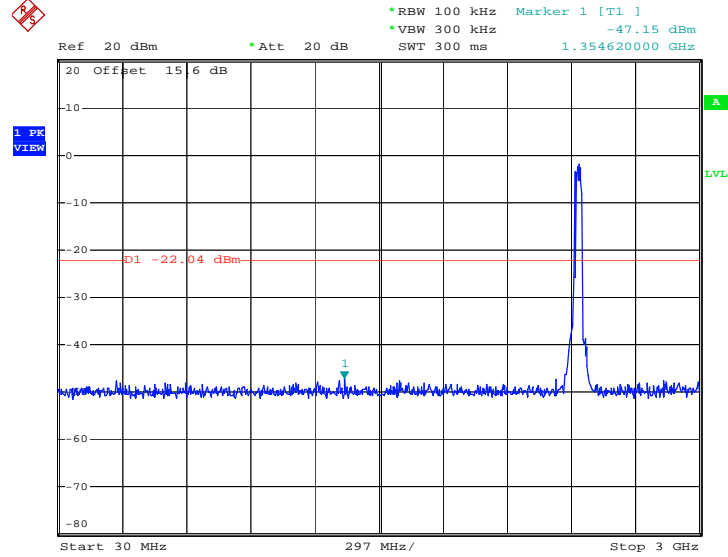

Date: 14.JUN.2013 21:31:17

2.4GHz 802.11n HT40 2 GHz~25 GHz

Conducted Spurious Emission Plot on Channel 06

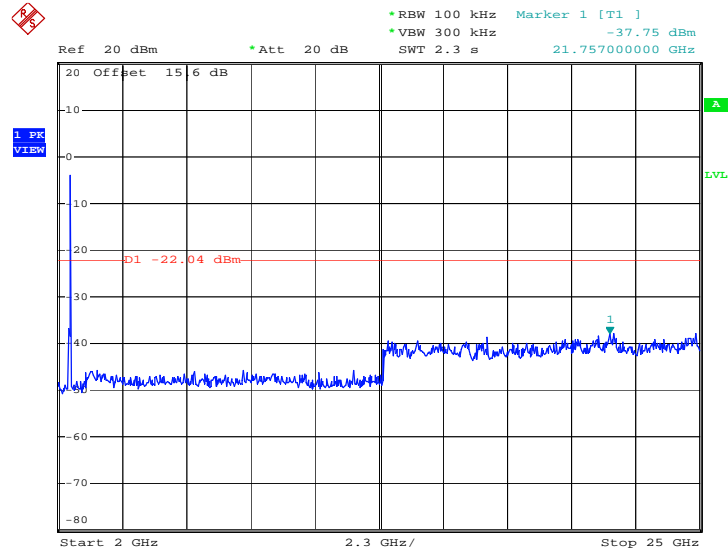

Date: 14.JUN.2013 21:31:36

2.4GHz 802.11n HT40 30 MHz~3 GHz

Conducted Spurious Emission Plot on Channel 09

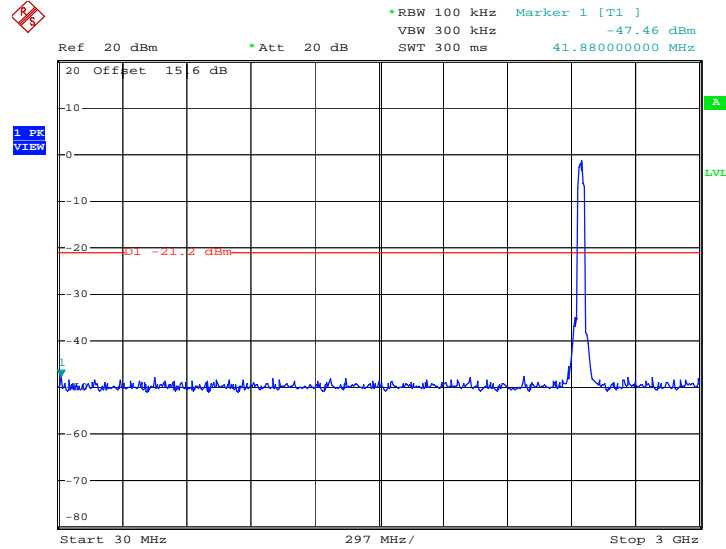

Date: 14.JUN.2013 21:35:34

2.4GHz 802.11n HT40 2 GHz~25 GHz

Conducted Spurious Emission Plot on Channel 09

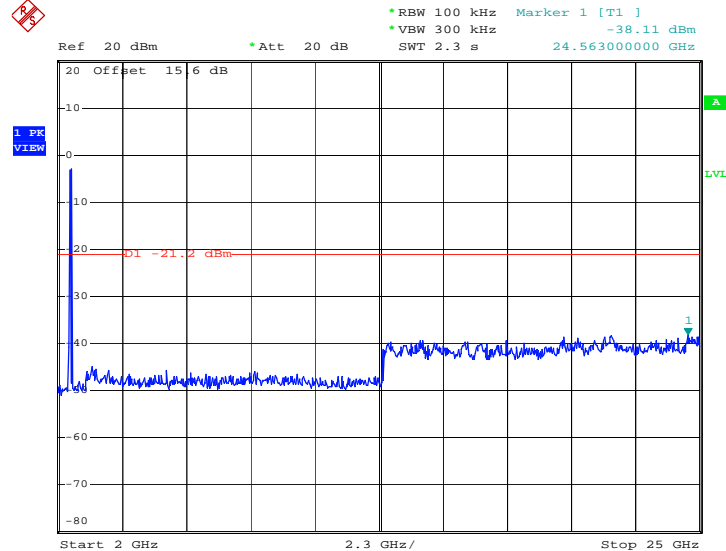

Date: 14.JUN.2013 21:34:13

3.5 Radiated Band Edges and Spurious Emission Measurement

3.5.1 Limit of Radiated band edge and Spurious Emission Measurement

In any 100 kHz bandwidth outside the intentional radiator frequency band, all harmonics/spurious must be at least 20 dB below the highest emission level within the authorized band. If the output power of this device was measured by spectrum analyzer, the attenuation under this paragraph shall be 30 dB instead of 20 dB. In addition, radiated emissions which fall in the restricted bands must also comply with the FCC section 15.209 limits as below.

Frequency (MHz)	Field Strength (microvolts/meter)	Measurement Distance (meters)
0.009 – 0.490	2400/F(kHz)	300
0.490 – 1.705	24000/F(kHz)	30
1.705 – 30.0	30	30
30 – 88	100	3
88 – 216	150	3
216 - 960	200	3
Above 960	500	3

3.5.2 Measuring Instruments

See list of measuring instruments of this test report.

3.5.3 Test Procedures

1. The testing follows the guidelines in ANSI C63.10-2009.
2. The EUT was arranged to its worst case and then tune the antenna tower (from 1 m to 4 m) and turntable (from 0 degree to 360 degrees) to find the maximum reading. A pre-amp and a high pass filter are used for the test in order to get better signal level.
3. The EUT was placed on a turntable with 0.8 meter above ground.
4. The EUT was set 3 meters from the interference receiving antenna, which was mounted on the top of a variable height antenna tower.
5. Corrected Reading: Antenna Factor + Cable Loss + Read Level - Preamp Factor = Level
6. For measurement below 1GHz, If the emission level of the EUT measured by the peak detector is 3 dB lower than the applicable limit, the peak emission level will be reported. Otherwise, the emission measurement will be repeated using the quasi-peak detector and reported.
7. Use the following spectrum analyzer settings:
 - (1) Span shall wide enough to fully capture the emission being measured;
 - (2) Set RBW=100 kHz for $f < 1$ GHz; $VBW \geq RBW$; Sweep = auto; Detector function = peak; Trace = max hold;
 - (3) Set RBW = 1 MHz, VBW= 3MHz for $f \geq 1$ GHz for peak measurement.
 For average measurement:
 - $VBW = 10$ Hz, when duty cycle is no less than 98 percent.
 - $VBW \geq 1/T$, when duty cycle is less than 98 percent where T is the minimum transmission duration over which the transmitter is on and is transmitting at its maximum power control level for the tested mode of operation.

Band	Duty Cycle(%)	T(ms)	1/T(kHz)	VBW Setting
802.11b	98.14	-	-	10Hz
802.11g	88.54	0.139	0.719	1kHz
2.4GHz 802.11n HT20	88.21	0.130	0.768	1kHz
2.4GHz 802.11n HT40	79.13	0.652	1.534	3kHz

Note: For average measurement with duty cycle < 98%, use reduced VBW measurement method 4.2.3.2.3 in ANSI C63.10.

3.5.4 Test Setup

For radiated emissions below 30MHz

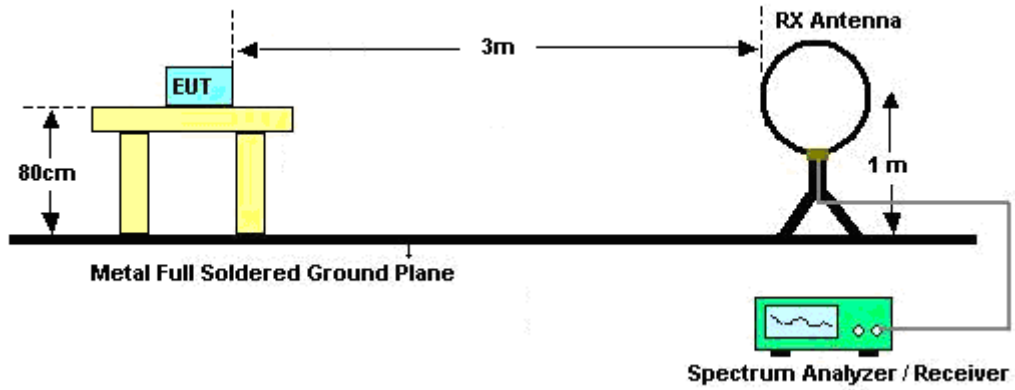

For radiated emissions from 30MHz to 1GHz

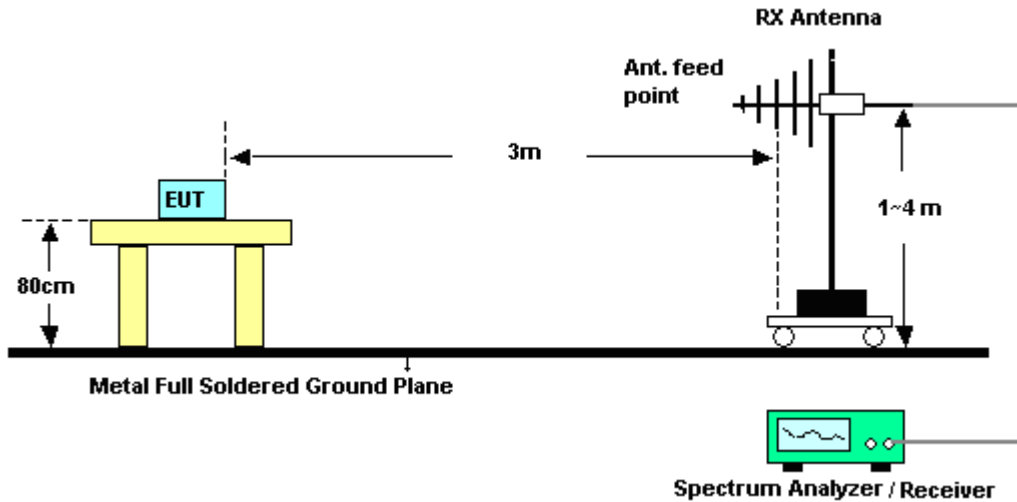

For radiated emissions above 1GHz

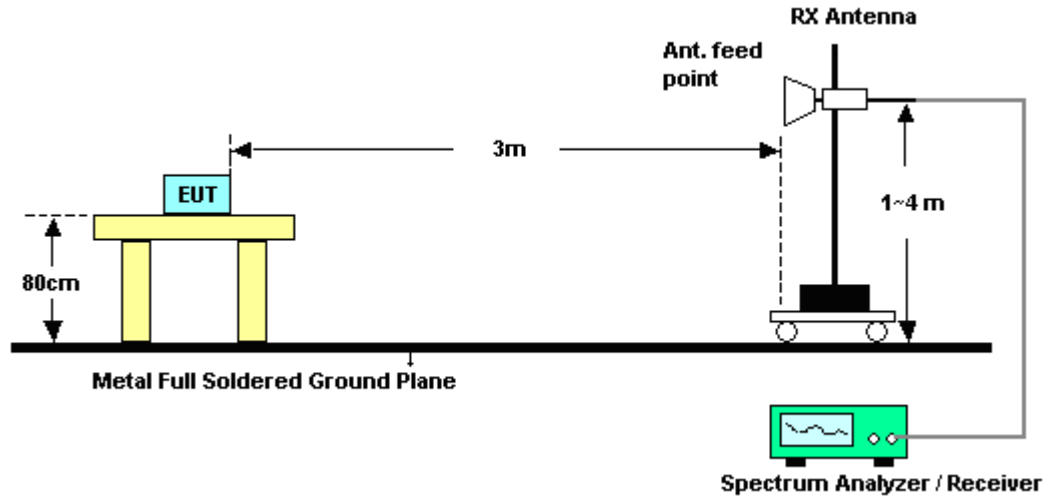

3.5.5 Test Results of Radiated Emissions (9kHz ~ 30MHz)

The low frequency, which started from 9 kHz to 30MHz, was pre-scanned and the result which was 20dB lower than the limit line per 15.31(o) was not reported.



3.5.6 Test Result of Radiated Band Edges

Test Mode :	802.11b	Temperature :	23~24°C
Test Band :	Low	Relative Humidity :	43~44%
Test Channel :	01	Test Engineer :	Stone Gu

ANTENNA POLARITY : HORIZONTAL										
Frequency (MHz)	Level (dBμV/m)	Over Limit (dB)	Limit Line (dBμV/m)	Read Level (dBμV)	Antenna Factor (dB)	Cable Loss (dB)	Preamp Factor (dB)	Ant Pos (cm)	Table Pos (deg)	Remark
2388.93	56.04	-17.96	74	51.79	32.86	2.9	31.51	100	35	Peak
2389.92	40.44	-13.56	54	36.18	32.86	2.91	31.51	100	35	Average

ANTENNA POLARITY : VERTICAL										
Frequency (MHz)	Level (dBμV/m)	Over Limit (dB)	Limit Line (dBμV/m)	Read Level (dBμV)	Antenna Factor (dB)	Cable Loss (dB)	Preamp Factor (dB)	Ant Pos (cm)	Table Pos (deg)	Remark
2389.29	50.62	-23.38	74	46.37	32.86	2.9	31.51	121	299	Peak
2390	37.25	-16.75	54	32.99	32.86	2.91	31.51	121	299	Average

Test Mode :	802.11b	Temperature :	23~24°C
Test Band :	High	Relative Humidity :	43~44%
Test Channel :	11	Test Engineer :	Stone Gu

ANTENNA POLARITY : HORIZONTAL										
Frequency (MHz)	Level (dBμV/m)	Over Limit (dB)	Limit Line (dBμV/m)	Read Level (dBμV)	Antenna Factor (dB)	Cable Loss (dB)	Preamp Factor (dB)	Ant Pos (cm)	Table Pos (deg)	Remark
2484.49	52.04	-21.96	74	47.58	33.01	2.96	31.51	100	165	Peak
2483.5	38.8	-15.2	54	34.34	33.01	2.96	31.51	100	165	Average

ANTENNA POLARITY : VERTICAL										
Frequency (MHz)	Level (dBμV/m)	Over Limit (dB)	Limit Line (dBμV/m)	Read Level (dBμV)	Antenna Factor (dB)	Cable Loss (dB)	Preamp Factor (dB)	Ant Pos (cm)	Table Pos (deg)	Remark
2488.69	51.38	-22.62	74	46.88	33.05	2.96	31.51	161	63	Peak
2483.5	37.67	-16.33	54	33.21	33.01	2.96	31.51	161	63	Average



Test Mode :	802.11g	Temperature :	23~24°C
Test Band :	Low	Relative Humidity :	43~44%
Test Channel :	01	Test Engineer :	Stone Gu

ANTENNA POLARITY : HORIZONTAL										
Frequency (MHz)	Level (dBμV/m)	Over Limit (dB)	Limit Line (dBμV/m)	Read Level (dBμV)	Antenna Factor (dB)	Cable Loss (dB)	Preamp Factor (dB)	Ant Pos (cm)	Table Pos (deg)	Remark
2389.56	69.29	-4.71	74	65.04	32.86	2.9	31.51	100	38	Peak
2389.83	48.75	-5.25	54	44.49	32.86	2.91	31.51	100	38	Average

ANTENNA POLARITY : VERTICAL										
Frequency (MHz)	Level (dBμV/m)	Over Limit (dB)	Limit Line (dBμV/m)	Read Level (dBμV)	Antenna Factor (dB)	Cable Loss (dB)	Preamp Factor (dB)	Ant Pos (cm)	Table Pos (deg)	Remark
2389.56	64.54	-9.46	74	60.29	32.86	2.9	31.51	197	33	Peak
2390	42.06	-11.94	54	37.8	32.86	2.91	31.51	197	33	Average

Test Mode :	802.11g	Temperature :	23~24°C
Test Band :	High	Relative Humidity :	43~44%
Test Channel :	11	Test Engineer :	Stone Gu

ANTENNA POLARITY : HORIZONTAL										
Frequency (MHz)	Level (dBμV/m)	Over Limit (dB)	Limit Line (dBμV/m)	Read Level (dBμV)	Antenna Factor (dB)	Cable Loss (dB)	Preamp Factor (dB)	Ant Pos (cm)	Table Pos (deg)	Remark
2483.8	70.69	-3.31	74	66.23	33.01	2.96	31.51	200	32	Peak
2483.59	47.25	-6.75	54	42.79	33.01	2.96	31.51	200	32	Average

ANTENNA POLARITY : VERTICAL										
Frequency (MHz)	Level (dBμV/m)	Over Limit (dB)	Limit Line (dBμV/m)	Read Level (dBμV)	Antenna Factor (dB)	Cable Loss (dB)	Preamp Factor (dB)	Ant Pos (cm)	Table Pos (deg)	Remark
2483.56	66.54	-7.46	74	62.08	33.01	2.96	31.51	126	153	Peak
2483.68	42.88	-11.12	54	38.42	33.01	2.96	31.51	126	153	Average



Test Mode :	802.11n HT20	Temperature :	23~24°C
Test Band :	Low	Relative Humidity :	43~44%
Test Channel :	01	Test Engineer :	Stone Gu

ANTENNA POLARITY : HORIZONTAL										
Frequency (MHz)	Level (dBμV/m)	Over Limit (dB)	Limit Line (dBμV/m)	Read Level (dBμV)	Antenna Factor (dB)	Cable Loss (dB)	Preamp Factor (dB)	Ant Pos (cm)	Table Pos (deg)	Remark
2382.72	64.78	-9.22	74	60.56	32.83	2.9	31.51	100	57	Peak
2390	48.07	-5.93	54	43.81	32.86	2.91	31.51	100	57	Average

ANTENNA POLARITY : VERTICAL										
Frequency (MHz)	Level (dBμV/m)	Over Limit (dB)	Limit Line (dBμV/m)	Read Level (dBμV)	Antenna Factor (dB)	Cable Loss (dB)	Preamp Factor (dB)	Ant Pos (cm)	Table Pos (deg)	Remark
2389.83	58.79	-15.21	74	54.53	32.86	2.91	31.51	198	35	Peak
2389.92	41.57	-12.43	54	37.31	32.86	2.91	31.51	198	35	Average

Test Mode :	802.11n HT20	Temperature :	23~24°C
Test Band :	High	Relative Humidity :	43~44%
Test Channel :	11	Test Engineer :	Stone Gu

ANTENNA POLARITY : HORIZONTAL										
Frequency (MHz)	Level (dBμV/m)	Over Limit (dB)	Limit Line (dBμV/m)	Read Level (dBμV)	Antenna Factor (dB)	Cable Loss (dB)	Preamp Factor (dB)	Ant Pos (cm)	Table Pos (deg)	Remark
2485.09	70.43	-3.57	74	65.97	33.01	2.96	31.51	100	39	Peak
2483.53	42.57	-11.43	54	38.11	33.01	2.96	31.51	100	39	Average

ANTENNA POLARITY : VERTICAL										
Frequency (MHz)	Level (dBμV/m)	Over Limit (dB)	Limit Line (dBμV/m)	Read Level (dBμV)	Antenna Factor (dB)	Cable Loss (dB)	Preamp Factor (dB)	Ant Pos (cm)	Table Pos (deg)	Remark
2484.22	66.41	-7.59	74	61.95	33.01	2.96	31.51	103	358	Peak
2483.53	40.81	-13.19	54	36.35	33.01	2.96	31.51	103	358	Average



Test Mode :	802.11n HT40	Temperature :	23~24°C
Test Band :	Low	Relative Humidity :	43~44%
Test Channel :	03	Test Engineer :	Stone Gu

ANTENNA POLARITY : HORIZONTAL										
Frequency (MHz)	Level (dBμV/m)	Over Limit (dB)	Limit Line (dBμV/m)	Read Level (dBμV)	Antenna Factor (dB)	Cable Loss (dB)	Preamp Factor (dB)	Ant Pos (cm)	Table Pos (deg)	Remark
2388.84	67.36	-6.64	74	63.11	32.86	2.9	31.51	100	17	Peak
2390	49.23	-4.77	54	44.97	32.86	2.91	31.51	100	17	Average

ANTENNA POLARITY : VERTICAL										
Frequency (MHz)	Level (dBμV/m)	Over Limit (dB)	Limit Line (dBμV/m)	Read Level (dBμV)	Antenna Factor (dB)	Cable Loss (dB)	Preamp Factor (dB)	Ant Pos (cm)	Table Pos (deg)	Remark
2388.57	63.6	-10.4	74	59.35	32.86	2.9	31.51	104	19	Peak
2390	46.2	-7.8	54	41.94	32.86	2.91	31.51	104	19	Average

Test Mode :	802.11n HT40	Temperature :	23~24°C
Test Band :	High	Relative Humidity :	43~44%
Test Channel :	09	Test Engineer :	Stone Gu

ANTENNA POLARITY : HORIZONTAL										
Frequency (MHz)	Level (dBμV/m)	Over Limit (dB)	Limit Line (dBμV/m)	Read Level (dBμV)	Antenna Factor (dB)	Cable Loss (dB)	Preamp Factor (dB)	Ant Pos (cm)	Table Pos (deg)	Remark
2486.38	64.93	-9.07	74	60.47	33.01	2.96	31.51	124	360	Peak
2487.16	42.8	-11.2	54	38.34	33.01	2.96	31.51	124	360	Average

ANTENNA POLARITY : VERTICAL										
Frequency (MHz)	Level (dBμV/m)	Over Limit (dB)	Limit Line (dBμV/m)	Read Level (dBμV)	Antenna Factor (dB)	Cable Loss (dB)	Preamp Factor (dB)	Ant Pos (cm)	Table Pos (deg)	Remark
2485.99	59.93	-14.07	74	55.47	33.01	2.96	31.51	135	21	Peak
2483.5	39.72	-14.28	54	35.26	33.01	2.96	31.51	135	21	Average

3.5.7 Test Result of Radiated Emission (30MHz ~ 10th Harmonic)

Note: Below 1GHz for radiated emission measurement, pre-scanned all test modes and only choose the worst case mode was recorded in the report.

Test Mode :	802.11b	Temperature :	23~24°C
Test Channel :	01	Relative Humidity :	43~44%
Test Engineer :	Stone Gu	Polarization :	Horizontal
Remark :	<ol style="list-style-type: none"> 2412 MHz is fundamental signal which can be ignored. 7236 MHz is not within a restricted band, and its limit line is 20dB below the highest emission level. For example, 107.42 dBμV/m - 20dB = 87.42 dBμV/m. Average measurement was not performed if peak level went lower than the average limit. 		

Frequency (MHz)	Level (dB μ V/m)	Over Limit (dB)	Limit Line (dB μ V/m)	Read Level (dB μ V)	Antenna Factor (dB)	Cable Loss (dB)	Preamp Factor (dB)	Ant Pos (cm)	Table Pos (deg)	Remark
2412	107.42	-	-	103.13	32.89	2.91	31.51	100	34	Peak
2412	101.28	-	-	96.99	32.89	2.91	31.51	100	34	Average
4824	50.3	-23.7	74	42.43	35.17	4.23	31.53	102	35	Peak
7236	53.13	-34.29	87.42	42.51	36.18	5.39	30.95	100	258	Peak



Test Mode :	802.11b	Temperature :	23~24°C
Test Channel :	01	Relative Humidity :	43~44%
Test Engineer :	Stone Gu	Polarization :	Vertical
Remark :	<ol style="list-style-type: none"> 2412 MHz is fundamental signal which can be ignored. 7236 MHz is not within a restricted band, and its limit line is 20dB below the highest emission level. Average measurement was not performed if peak level went lower than the average limit. 		

Frequency (MHz)	Level (dBμV/m)	Over Limit (dB)	Limit Line (dBμV/m)	Read Level (dBμV)	Antenna Factor (dB)	Cable Loss (dB)	Preamp Factor (dB)	Ant Pos (cm)	Table Pos (deg)	Remark
2412	100.15	-	-	95.86	32.89	2.91	31.51	100	300	Peak
2412	94.18	-	-	89.89	32.89	2.91	31.51	100	300	Average
4824	49.81	-24.19	74	41.94	35.17	4.23	31.53	142	355	Peak
7236	53.16	-26.99	80.15	42.54	36.18	5.39	30.95	100	21	Peak



Test Mode :	802.11b	Temperature :	23~24°C
Test Channel :	06	Relative Humidity :	43~44%
Test Engineer :	Stone Gu	Polarization :	Horizontal
Remark :	1. 2437 MHz is fundamental signal which can be ignored. 2. Average measurement was not performed if peak level went lower than the average limit.		

Frequency (MHz)	Level (dBμV/m)	Over Limit (dB)	Limit Line (dBμV/m)	Read Level (dBμV)	Antenna Factor (dB)	Cable Loss (dB)	Preamp Factor (dB)	Ant Pos (cm)	Table Pos (deg)	Remark
2437	107.71	-	-	103.34	32.95	2.93	31.51	124	166	Peak
2437	101.72	-	-	97.35	32.95	2.93	31.51	124	166	Average
4874	49.31	-24.69	74	41.39	35.18	4.26	31.52	100	225	Peak
7311	51.99	-22.01	74	41.29	36.2	5.44	30.94	124	74	Peak



Test Mode :	802.11b	Temperature :	23~24°C
Test Channel :	06	Relative Humidity :	43~44%
Test Engineer :	Stone Gu	Polarization :	Vertical
Remark :	1. 2437 MHz is fundamental signal which can be ignored. 2. Average measurement was not performed if peak level went lower than the average limit.		

Frequency (MHz)	Level (dBμV/m)	Over Limit (dB)	Limit Line (dBμV/m)	Read Level (dBμV)	Antenna Factor (dB)	Cable Loss (dB)	Preamp Factor (dB)	Ant Pos (cm)	Table Pos (deg)	Remark
2437	100.5	-	-	96.13	32.95	2.93	31.51	147	274	Peak
2437	94.75	-	-	90.38	32.95	2.93	31.51	147	274	Average
4874	49.61	-24.39	74	41.69	35.18	4.26	31.52	124	98	Peak
7311	51.91	-22.09	74	41.21	36.2	5.44	30.94	102	55	Peak



Test Mode :	802.11b	Temperature :	23~24°C
Test Channel :	11	Relative Humidity :	43~44%
Test Engineer :	Stone Gu	Polarization :	Horizontal
Remark :	1. 2462 MHz is fundamental signal which can be ignored. 2. Average measurement was not performed if peak level went lower than the average limit.		

Frequency (MHz)	Level (dBμV/m)	Over Limit (dB)	Limit Line (dBμV/m)	Read Level (dBμV)	Antenna Factor (dB)	Cable Loss (dB)	Preamp Factor (dB)	Ant Pos (cm)	Table Pos (deg)	Remark
2462	107.07	-	-	102.66	32.98	2.94	31.51	173	34	Peak
2462	101.27	-	-	96.86	32.98	2.94	31.51	173	34	Average
4924	50.18	-23.82	74	42.22	35.19	4.28	31.51	121	12	Peak
7386	52.42	-21.58	74	41.6	36.24	5.51	30.93	124	66	Peak



Test Mode :	802.11b	Temperature :	23~24°C
Test Channel :	11	Relative Humidity :	43~44%
Test Engineer :	Stone Gu	Polarization :	Vertical
Remark :	1. 2462 MHz is fundamental signal which can be ignored. 2. Average measurement was not performed if peak level went lower than the average limit.		

Frequency (MHz)	Level (dBμV/m)	Over Limit (dB)	Limit Line (dBμV/m)	Read Level (dBμV)	Antenna Factor (dB)	Cable Loss (dB)	Preamp Factor (dB)	Ant Pos (cm)	Table Pos (deg)	Remark
2462	101.74	-	-	97.33	32.98	2.94	31.51	132	326	Peak
2462	95.96	-	-	91.55	32.98	2.94	31.51	132	326	Average
4924	50.67	-23.33	74	42.71	35.19	4.28	31.51	100	47	Peak
7386	53.18	-20.82	74	42.36	36.24	5.51	30.93	100	0	Peak



Test Mode :	802.11g	Temperature :	23~24°C
Test Channel :	01	Relative Humidity :	43~44%
Test Engineer :	Stone Gu	Polarization :	Horizontal
Remark :	1. 2412 MHz is fundamental signal which can be ignored. 2. 7236 MHz is not within a restricted band, and its limit line is 20dB below the highest emission level. 3. Average measurement was not performed if peak level went lower than the average limit.		

Frequency (MHz)	Level (dBμV/m)	Over Limit (dB)	Limit Line (dBμV/m)	Read Level (dBμV)	Antenna Factor (dB)	Cable Loss (dB)	Preamp Factor (dB)	Ant Pos (cm)	Table Pos (deg)	Remark
2412	108.17	-	-	103.88	32.89	2.91	31.51	100	35	Peak
2412	97.22	-	-	92.93	32.89	2.91	31.51	100	35	Average
4824	50.06	-23.94	74	42.19	35.17	4.23	31.53	154	47	Peak
7236	53.58	-34.59	88.17	42.96	36.18	5.39	30.95	100	0	Peak



Test Mode :	802.11g	Temperature :	23~24°C
Test Channel :	01	Relative Humidity :	43~44%
Test Engineer :	Stone Gu	Polarization :	Vertical
Remark :	1. 2412 MHz is fundamental signal which can be ignored. 2. 7236 MHz is not within a restricted band, and its limit line is 20dB below the highest emission level. 3. Average measurement was not performed if peak level went lower than the average limit.		

Frequency (MHz)	Level (dBμV/m)	Over Limit (dB)	Limit Line (dBμV/m)	Read Level (dBμV)	Antenna Factor (dB)	Cable Loss (dB)	Preamp Factor (dB)	Ant Pos (cm)	Table Pos (deg)	Remark
2412	100.79	-	-	96.5	32.89	2.91	31.51	175	299	Peak
2412	89.65	-	-	85.36	32.89	2.91	31.51	175	299	Average
4824	50.98	-23.02	74	43.11	35.17	4.23	31.53	100	53	Peak
7236	52.24	-28.55	80.79	41.62	36.18	5.39	30.95	125	298	Peak



Test Mode :	802.11g	Temperature :	23~24°C
Test Channel :	06	Relative Humidity :	43~44%
Test Engineer :	Stone Gu	Polarization :	Horizontal
Remark :	1. 2437 MHz is fundamental signal which can be ignored. 2. Average measurement was not performed if peak level went lower than the average limit.		

Frequency (MHz)	Level (dBμV/m)	Over Limit (dB)	Limit Line (dBμV/m)	Read Level (dBμV)	Antenna Factor (dB)	Cable Loss (dB)	Preamp Factor (dB)	Ant Pos (cm)	Table Pos (deg)	Remark
2437	109.18	-	-	104.81	32.95	2.93	31.51	100	36	Peak
2437	98.67	-	-	94.3	32.95	2.93	31.51	100	36	Average
4874	50.77	-23.23	74	42.85	35.18	4.26	31.52	154	89	Peak
7311	52.84	-21.16	74	42.14	36.2	5.44	30.94	157	183	Peak



Test Mode :	802.11g	Temperature :	23~24°C
Test Channel :	06	Relative Humidity :	43~44%
Test Engineer :	Stone Gu	Polarization :	Vertical
Remark :	1. 2437 MHz is fundamental signal which can be ignored. 2. Average measurement was not performed if peak level went lower than the average limit.		

Frequency (MHz)	Level (dBμV/m)	Over Limit (dB)	Limit Line (dBμV/m)	Read Level (dBμV)	Antenna Factor (dB)	Cable Loss (dB)	Preamp Factor (dB)	Ant Pos (cm)	Table Pos (deg)	Remark
2437	102.52	-	-	98.15	32.95	2.93	31.51	196	33	Peak
2437	91.14	-	-	86.77	32.95	2.93	31.51	196	33	Average
4874	50.58	-23.42	74	42.66	35.18	4.26	31.52	145	67	Peak
7311	52.78	-21.22	74	42.08	36.2	5.44	30.94	124	80	Peak



Test Mode :	802.11g	Temperature :	23~24°C
Test Channel :	11	Relative Humidity :	43~44%
Test Engineer :	Stone Gu	Polarization :	Horizontal
Remark :	1. 2462 MHz is fundamental signal which can be ignored. 2. Average measurement was not performed if peak level went lower than the average limit.		

Frequency (MHz)	Level (dBμV/m)	Over Limit (dB)	Limit Line (dBμV/m)	Read Level (dBμV)	Antenna Factor (dB)	Cable Loss (dB)	Preamp Factor (dB)	Ant Pos (cm)	Table Pos (deg)	Remark
30	19.3	-20.7	40	34.53	18	0.34	33.57	-	-	Peak
122.15	12	-31.5	43.5	33.18	11.78	0.64	33.6	-	-	Peak
274.44	14.9	-31.1	46	34.85	12.5	0.96	33.41	-	-	Peak
626.55	19.54	-26.46	46	32.3	18.76	1.43	32.95	-	-	Peak
884.57	22.48	-23.52	46	32.78	20.47	1.73	32.5	-	-	Peak
941.8	26.81	-19.19	46	36.8	20.7	1.75	32.44	137	189	Peak
2462	107.22	-	-	102.81	32.98	2.94	31.51	174	37	Peak
2462	96.74	-	-	92.33	32.98	2.94	31.51	174	37	Average
4924	50.27	-23.73	74	42.31	35.19	4.28	31.51	100	23	Peak
7386	53.13	-20.87	74	42.31	36.24	5.51	30.93	148	73	Peak



Test Mode :	802.11g	Temperature :	23~24°C
Test Channel :	11	Relative Humidity :	43~44%
Test Engineer :	Stone Gu	Polarization :	Vertical
Remark :	1. 2462 MHz is fundamental signal which can be ignored. 2. Average measurement was not performed if peak level went lower than the average limit.		

Frequency (MHz)	Level (dBμV/m)	Over Limit (dB)	Limit Line (dBμV/m)	Read Level (dBμV)	Antenna Factor (dB)	Cable Loss (dB)	Preamp Factor (dB)	Ant Pos (cm)	Table Pos (deg)	Remark
32.91	20.27	-19.73	40	37.47	16.04	0.35	33.59	-	-	Peak
196.84	22.76	-20.74	43.5	46.64	8.86	0.82	33.56	-	-	Peak
672.14	19.61	-26.39	46	31.98	19.07	1.48	32.92	-	-	Peak
797.27	21.23	-24.77	46	32.36	19.85	1.65	32.63	-	-	Peak
941.8	27.7	-18.3	46	37.69	20.7	1.75	32.44	123	65	Peak
985.45	22.05	-31.95	54	31.64	21.01	1.83	32.43	-	-	Peak
2462	101.95	-	-	97.54	32.98	2.94	31.51	136	311	Peak
2462	90.44	-	-	86.03	32.98	2.94	31.51	136	311	Average
4924	50.05	-23.95	74	42.09	35.19	4.28	31.51	128	41	Peak
7386	52.92	-21.08	74	42.1	36.24	5.51	30.93	108	39	Peak



Test Mode :	2.4GHz 802.11n HT20	Temperature :	23~24°C
Test Channel :	01	Relative Humidity :	43~44%
Test Engineer :	Stone Gu	Polarization :	Horizontal
Remark :	<ol style="list-style-type: none"> 1. 2412 MHz is fundamental signal which can be ignored. 2. 7236 MHz is not within a restricted band, and its limit line is 20dB below the highest emission level. 3. Average measurement was not performed if peak level went lower than the average limit. 		

Frequency (MHz)	Level (dBμV/m)	Over Limit (dB)	Limit Line (dBμV/m)	Read Level (dBμV)	Antenna Factor (dB)	Cable Loss (dB)	Preamp Factor (dB)	Ant Pos (cm)	Table Pos (deg)	Remark
2412	105.71	-	-	101.42	32.89	2.91	31.51	100	165	Peak
2412	94.42	-	-	90.13	32.89	2.91	31.51	100	165	Average
4824	49.76	-24.24	74	41.89	35.17	4.23	31.53	100	67	Peak
7236	52.14	-33.57	85.71	41.52	36.18	5.39	30.95	245	31	Peak



Test Mode :	2.4GHz 802.11n HT20	Temperature :	23~24°C
Test Channel :	01	Relative Humidity :	43~44%
Test Engineer :	Stone Gu	Polarization :	Vertical
Remark :	1. 2412 MHz is fundamental signal which can be ignored. 2. 7236 MHz is not within a restricted band, and its limit line is 20dB below the highest emission level. 3. Average measurement was not performed if peak level went lower than the average limit.		

Frequency (MHz)	Level (dBμV/m)	Over Limit (dB)	Limit Line (dBμV/m)	Read Level (dBμV)	Antenna Factor (dB)	Cable Loss (dB)	Preamp Factor (dB)	Ant Pos (cm)	Table Pos (deg)	Remark
2412	97.88	-	-	93.59	32.89	2.91	31.51	120	299	Peak
2412	87.44	-	-	83.15	32.89	2.91	31.51	120	299	Average
4824	49.27	-24.73	74	41.4	35.17	4.23	31.53	154	63	Peak
7236	51.3	-26.58	77.88	40.68	36.18	5.39	30.95	127	33	Peak



Test Mode :	2.4GHz 802.11n HT20	Temperature :	23~24°C
Test Channel :	06	Relative Humidity :	43~44%
Test Engineer :	Stone Gu	Polarization :	Horizontal
Remark :	1. 2437 MHz is fundamental signal which can be ignored. 2. Average measurement was not performed if peak level went lower than the average limit.		

Frequency (MHz)	Level (dBμV/m)	Over Limit (dB)	Limit Line (dBμV/m)	Read Level (dBμV)	Antenna Factor (dB)	Cable Loss (dB)	Preamp Factor (dB)	Ant Pos (cm)	Table Pos (deg)	Remark
2437	105.53	-	-	101.16	32.95	2.93	31.51	100	35	Peak
2437	94.53	-	-	90.16	32.95	2.93	31.51	100	35	Average
4874	50.8	-23.2	74	42.88	35.18	4.26	31.52	123	57	Peak
7311	51.99	-22.01	74	41.29	36.2	5.44	30.94	135	97	Peak



Test Mode :	2.4GHz 802.11n HT20	Temperature :	23~24°C
Test Channel :	06	Relative Humidity :	43~44%
Test Engineer :	Stone Gu	Polarization :	Vertical
Remark :	1. 2437 MHz is fundamental signal which can be ignored. 2. Average measurement was not performed if peak level went lower than the average limit.		

Frequency (MHz)	Level (dBμV/m)	Over Limit (dB)	Limit Line (dBμV/m)	Read Level (dBμV)	Antenna Factor (dB)	Cable Loss (dB)	Preamp Factor (dB)	Ant Pos (cm)	Table Pos (deg)	Remark
2437	97.8	-	-	93.43	32.95	2.93	31.51	116	272	Peak
2437	86.82	-	-	82.45	32.95	2.93	31.51	116	272	Average
4874	49.5	-24.5	74	41.58	35.18	4.26	31.52	123	63	Peak
7311	51.65	-22.35	74	40.95	36.2	5.44	30.94	156	323	Peak



Test Mode :	2.4GHz 802.11n HT20	Temperature :	23~24°C
Test Channel :	11	Relative Humidity :	43~44%
Test Engineer :	Stone Gu	Polarization :	Horizontal
Remark :	1. 2462 MHz is fundamental signal which can be ignored. 2. Average measurement was not performed if peak level went lower than the average limit.		

Frequency (MHz)	Level (dBμV/m)	Over Limit (dB)	Limit Line (dBμV/m)	Read Level (dBμV)	Antenna Factor (dB)	Cable Loss (dB)	Preamp Factor (dB)	Ant Pos (cm)	Table Pos (deg)	Remark
2462	104.94	-	-	100.53	32.98	2.94	31.51	173	36	Peak
2462	93.89	-	-	89.48	32.98	2.94	31.51	173	36	Average
4924	49.44	-24.56	74	41.48	35.19	4.28	31.51	135	64	Peak
7386	52.41	-21.59	74	41.59	36.24	5.51	30.93	132	67	Peak



Test Mode :	2.4GHz 802.11n HT20	Temperature :	23~24°C
Test Channel :	11	Relative Humidity :	43~44%
Test Engineer :	Stone Gu	Polarization :	Vertical
Remark :	1. 2462 MHz is fundamental signal which can be ignored. 2. Average measurement was not performed if peak level went lower than the average limit.		

Frequency (MHz)	Level (dBμV/m)	Over Limit (dB)	Limit Line (dBμV/m)	Read Level (dBμV)	Antenna Factor (dB)	Cable Loss (dB)	Preamp Factor (dB)	Ant Pos (cm)	Table Pos (deg)	Remark
2462	97.52	-	-	93.11	32.98	2.94	31.51	100	309	Peak
2462	86.97	-	-	82.56	32.98	2.94	31.51	100	309	Average
4924	50.43	-23.57	74	42.47	35.19	4.28	31.51	100	0	Peak
7386	51.97	-22.03	74	41.15	36.24	5.51	30.93	134	341	Peak



Test Mode :	2.4GHz 802.11n HT40	Temperature :	23~24°C
Test Channel :	03	Relative Humidity :	43~44%
Test Engineer :	Stone Gu	Polarization :	Horizontal
Remark :	1. 2422 MHz is fundamental signal which can be ignored. 2. Average measurement was not performed if peak level went lower than the average limit.		

Frequency (MHz)	Level (dBμV/m)	Over Limit (dB)	Limit Line (dBμV/m)	Read Level (dBμV)	Antenna Factor (dB)	Cable Loss (dB)	Preamp Factor (dB)	Ant Pos (cm)	Table Pos (deg)	Remark
2422	100.02	-	-	95.68	32.92	2.93	31.51	100	0	Peak
2422	88.11	-	-	83.77	32.92	2.93	31.51	100	0	Average
4844	50.16	-23.84	74	42.26	35.18	4.25	31.53	103	315	Peak
7266	53.5	-20.5	74	42.85	36.19	5.41	30.95	100	237	Peak



Test Mode :	2.4GHz 802.11n HT40	Temperature :	23~24°C
Test Channel :	03	Relative Humidity :	43~44%
Test Engineer :	Stone Gu	Polarization :	Vertical
Remark :	1. 2422 MHz is fundamental signal which can be ignored. 2. Average measurement was not performed if peak level went lower than the average limit.		

Frequency (MHz)	Level (dBμV/m)	Over Limit (dB)	Limit Line (dBμV/m)	Read Level (dBμV)	Antenna Factor (dB)	Cable Loss (dB)	Preamp Factor (dB)	Ant Pos (cm)	Table Pos (deg)	Remark
2422	95.65	-	-	91.31	32.92	2.93	31.51	138	69	Peak
2422	84.56	-	-	80.22	32.92	2.93	31.51	138	69	Average
4844	50.06	-23.94	74	42.16	35.18	4.25	31.53	100	348	Peak
7266	52.09	-21.91	74	41.44	36.19	5.41	30.95	124	89	Peak



Test Mode :	2.4GHz 802.11n HT40	Temperature :	23~24°C
Test Channel :	06	Relative Humidity :	43~44%
Test Engineer :	Stone Gu	Polarization :	Horizontal
Remark :	1. 2437 MHz is fundamental signal which can be ignored. 2. Average measurement was not performed if peak level went lower than the average limit.		

Frequency (MHz)	Level (dBμV/m)	Over Limit (dB)	Limit Line (dBμV/m)	Read Level (dBμV)	Antenna Factor (dB)	Cable Loss (dB)	Preamp Factor (dB)	Ant Pos (cm)	Table Pos (deg)	Remark
2437	100.56	-	-	96.19	32.95	2.93	31.51	148	45	Peak
2437	89.56	-	-	85.19	32.95	2.93	31.51	148	45	Average
4874	49.46	-24.54	74	41.54	35.18	4.26	31.52	134	66	Peak
7311	52.42	-21.58	74	41.72	36.2	5.44	30.94	124	63	Peak



Test Mode :	2.4GHz 802.11n HT40	Temperature :	23~24°C
Test Channel :	06	Relative Humidity :	43~44%
Test Engineer :	Stone Gu	Polarization :	Vertical
Remark :	1. 2437 MHz is fundamental signal which can be ignored. 2. Average measurement was not performed if peak level went lower than the average limit.		

Frequency (MHz)	Level (dBμV/m)	Over Limit (dB)	Limit Line (dBμV/m)	Read Level (dBμV)	Antenna Factor (dB)	Cable Loss (dB)	Preamp Factor (dB)	Ant Pos (cm)	Table Pos (deg)	Remark
2437	95.02	-	-	90.65	32.95	2.93	31.51	130	14	Peak
2437	84.55	-	-	80.18	32.95	2.93	31.51	130	14	Average
4874	49.43	-24.57	74	41.51	35.18	4.26	31.52	100	199	Peak
7311	52.5	-21.5	74	41.8	36.2	5.44	30.94	164	82	Peak



Test Mode :	2.4GHz 802.11n HT40	Temperature :	23~24°C
Test Channel :	09	Relative Humidity :	43~44%
Test Engineer :	Stone Gu	Polarization :	Horizontal
Remark :	1. 2452 MHz is fundamental signal which can be ignored. 2. Average measurement was not performed if peak level went lower than the average limit.		

Frequency (MHz)	Level (dBμV/m)	Over Limit (dB)	Limit Line (dBμV/m)	Read Level (dBμV)	Antenna Factor (dB)	Cable Loss (dB)	Preamp Factor (dB)	Ant Pos (cm)	Table Pos (deg)	Remark
2452	99.76	-	-	95.38	32.95	2.94	31.51	124	360	Peak
2452	89.24	-	-	84.86	32.95	2.94	31.51	124	360	Average
4904	50.35	-23.65	74	42.41	35.19	4.27	31.52	100	231	Peak
7356	52.28	-21.72	74	41.5	36.22	5.49	30.93	134	229	Peak



Test Mode :	2.4GHz 802.11n HT40	Temperature :	23~24°C
Test Channel :	09	Relative Humidity :	43~44%
Test Engineer :	Stone Gu	Polarization :	Vertical
Remark :	1. 2452 MHz is fundamental signal which can be ignored. 2. Average measurement was not performed if peak level went lower than the average limit.		

Frequency (MHz)	Level (dBμV/m)	Over Limit (dB)	Limit Line (dBμV/m)	Read Level (dBμV)	Antenna Factor (dB)	Cable Loss (dB)	Preamp Factor (dB)	Ant Pos (cm)	Table Pos (deg)	Remark
2452	95.26	-	-	90.88	32.95	2.94	31.51	135	21	Peak
2452	83.5	-	-	79.12	32.95	2.94	31.51	135	21	Average
4904	48.99	-25.01	74	41.05	35.19	4.27	31.52	123	48	Peak
7356	51.73	-22.27	74	40.95	36.22	5.49	30.93	100	0	Peak

3.6 AC Conducted Emission Measurement

3.6.1 Limit of AC Conducted Emission

For equipment that is designed to be connected to the public utility (AC) power line, the radio frequency voltage that is conducted back onto the AC power line on any frequency or frequencies within the band 150 kHz to 30 MHz shall not exceed the limits in the following table.

Frequency of Emission (MHz)	Conducted Limit (dB μ V)	
	Quasi-Peak	Average
0.15-0.5	66 to 56*	56 to 46*
0.5-5	56	46
5-30	60	50

*Decreases with the logarithm of the frequency.

3.6.2 Measuring Instruments

See list of measuring instruments of this test report.

3.6.3 Test Procedures

1. The testing follows the guidelines in ANSI C63.10-2009.
2. The EUT was placed 0.4 meter from the conducting wall of the shielding room, and it was kept at least 80 centimeters from any other grounded conducting surface.
3. Connect EUT to the power mains through a line impedance stabilization network (LISN).
4. All the support units are connecting to the other LISN.
5. The LISN provides 50 ohm coupling impedance for the measuring instrument.
6. The FCC states that a 50 ohm, 50 microhenry LISN should be used.
7. Both sides of AC line were checked for maximum conducted interference.
8. The frequency range from 150 kHz to 30 MHz was searched.
9. Set the test-receiver system to Peak Detect Function and specified bandwidth with Maximum Hold Mode.

3.6.4 Test Setup

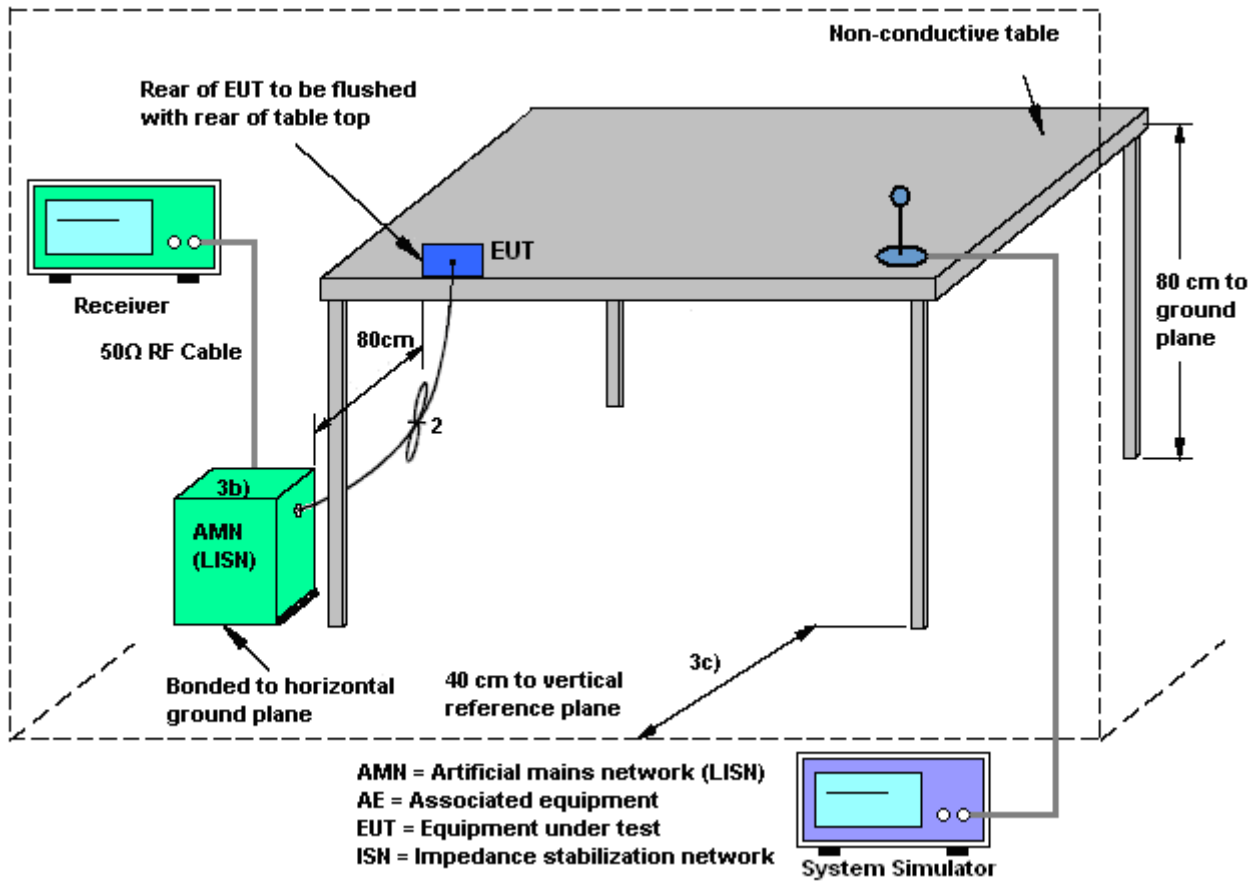

3.6.5 Test Result of AC Conducted Emission

Test Mode :	Mode 1	Temperature :	19~20°C
Test Engineer :	Tom Wang	Relative Humidity :	39~40%
Test Voltage :	120Vac / 60Hz	Phase :	Line
Function Type :	GSM850 Idle + Bluetooth Link + WLAN Link + USB Cable (Charging from Adapter) + Earphone		

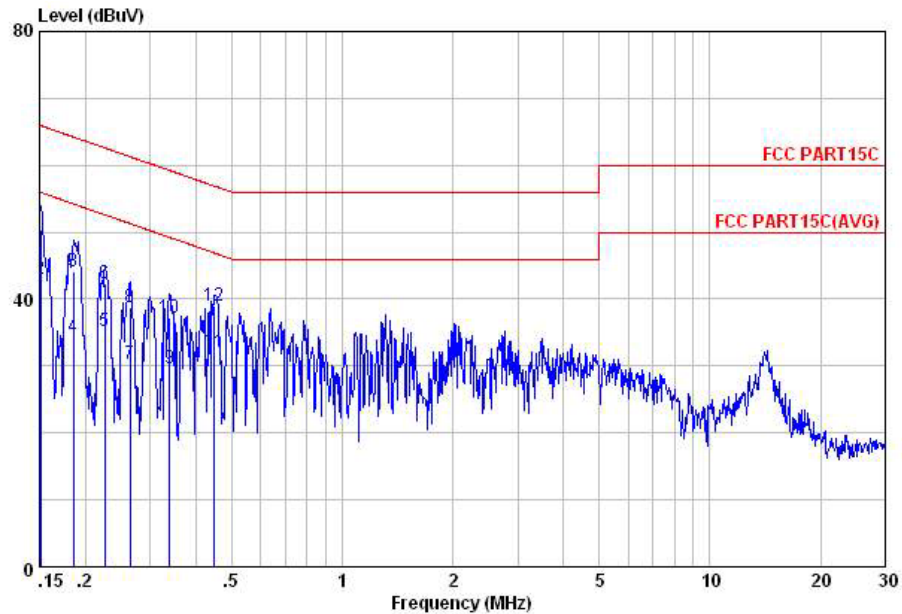

Site : C001-KS
 Condition: FCC PART15C LISN-L20130306 LINE

	Freq	Level	Over	Limit	Read	LISN	Cable	
	MHz	dBuV	Limit	Line	Level	Factor	Loss	Remark
			dB	dBuV	dBuV	dB	dB	
1	0.15	50.25	-15.71	65.96	37.59	1.94	10.72	QP
2	0.15	43.05	-12.91	55.96	30.39	1.94	10.72	Average
3	0.19	44.20	-20.04	64.24	32.39	1.20	10.61	QP
4	0.19	34.40	-19.84	54.24	22.59	1.20	10.61	Average
5	0.23	35.19	-17.42	52.61	23.71	0.94	10.54	Average
6	0.23	42.39	-20.22	62.61	30.91	0.94	10.54	QP
7	0.26	30.41	-20.88	51.29	19.11	0.83	10.47	Average
8	0.26	38.71	-22.58	61.29	27.41	0.83	10.47	QP
9	0.34	29.71	-19.51	49.22	18.91	0.47	10.33	Average
10	0.34	37.11	-22.11	59.22	26.31	0.47	10.33	QP
11	0.45	32.12	-14.77	46.89	21.60	0.25	10.27	Average
12	0.45	38.92	-17.97	56.89	28.40	0.25	10.27	QP



Test Mode :	Mode 1	Temperature :	19~20°C
Test Engineer :	Tom Wang	Relative Humidity :	39~40%
Test Voltage :	120Vac / 60Hz	Phase :	Neutral
Function Type :	GSM850 Idle + Bluetooth Link + WLAN Link + USB Cable (Charging from Adapter) + Earphone		

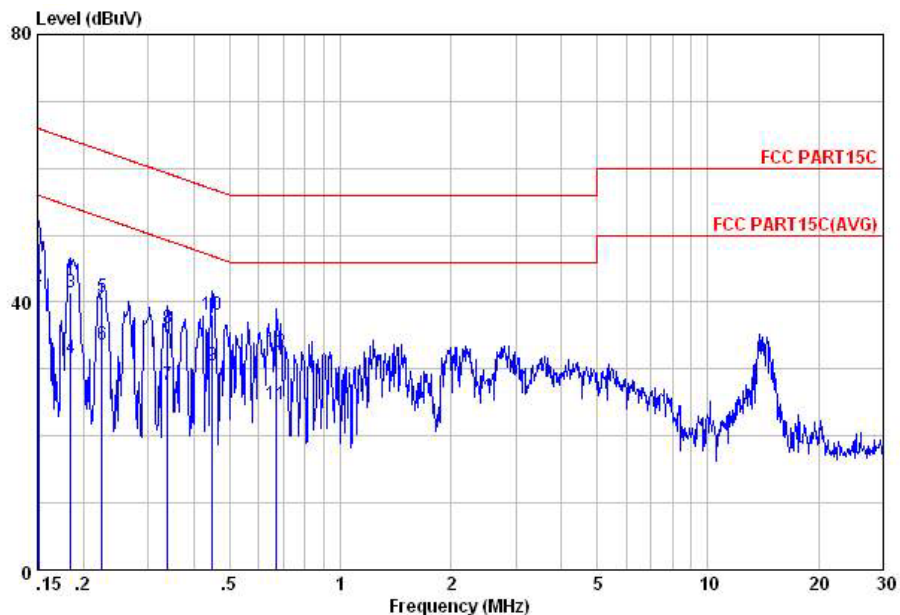

Site : C001-KS
Condition: FCC PART15C LISN-N20130306 NEUTRAL

	Freq	Level	Over	Limit	Read	LISN	Cable	Remark
	MHz	dBuV	Limit	Line	Level	Factor	Loss	
			dB	dBuV	dBuV	dB	dB	
1	0.15	48.70	-17.26	65.96	36.09	1.89	10.72	QP
2	0.15	42.40	-13.56	55.96	29.79	1.89	10.72	Average
3	0.18	41.51	-22.77	64.28	29.70	1.20	10.61	QP
4	0.18	31.61	-22.67	54.28	19.80	1.20	10.61	Average
5	0.22	40.80	-21.86	62.66	29.30	0.95	10.55	QP
6	0.22	33.60	-19.06	52.66	22.10	0.95	10.55	Average
7	0.34	27.67	-21.55	49.22	16.80	0.54	10.33	Average
8	0.34	36.07	-23.15	59.22	25.20	0.54	10.33	QP
9	0.45	30.62	-16.27	46.89	20.01	0.34	10.27	Average
10	0.45	38.22	-18.67	56.89	27.61	0.34	10.27	QP
11	0.67	24.63	-21.37	46.00	14.20	0.21	10.22	Average
12	0.67	32.43	-23.57	56.00	22.00	0.21	10.22	QP



3.7 Antenna Requirements

3.7.1 Standard Applicable

If directional gain of transmitting antennas is greater than 6dBi, the power shall be reduced by the same level in dB comparing to gain minus 6dBi. For the fixed point-to-point operation, the power shall be reduced by one dB for every 3 dB that the directional gain of the antenna exceeds 6 dBi. The use of a permanently attached antenna or of an antenna that uses a unique coupling to the intentional radiator shall be considered sufficient to comply with the FCC rule.

3.7.2 Antenna Connected Construction

Non-standard connector used.

3.7.3 Antenna Gain

The antenna peak gain of EUT is less than 6 dBi. Therefore, it is not necessary to reduce maximum peak output power limit.



4 List of Measuring Equipment

Instrument	Manufacturer	Model No.	Serial No.	Characteristics	Calibration Date	Test Date	Due Date	Remark
Spectrum Analyzer	R&S	FSP40	100319	9kHz~40GHz	Dec. 29, 2012	Jun. 14, 2013~ Jun. 15, 2013	Dec. 28, 2013	Conducted (TH01-KS)
Power Meter	Agilent	E4416A	MY45101555	N/A	Aug. 22, 2012	Jun. 14, 2013~ Jun. 15, 2013	Aug. 21, 2013	Conducted (TH01-KS)
Power Sensor	Agilent	E9327A	MY44421198	N/A	Aug. 22, 2012	Jun. 14, 2013~ Jun. 15, 2013	Aug. 21, 2013	Conducted (TH01-KS)
EMI Test Receiver	R&S	ESCI	100534	9kHz~3GHz	Nov. 08, 2012	Jun. 16, 2013	Nov. 07, 2013	Radiation (03CH01-KS)
Spectrum Analyzer	R&S	FSP30	100400	9kHz~30GHz	May 23, 2013	Jun. 16, 2013	May 22, 2014	Radiation (03CH01-KS)
Bilog Antenna	SCHAFFNER	CBL6112D	23182	25MHz~2GHz	Dec. 07, 2012	Jun. 16, 2013	Dec. 06, 2013	Radiation (03CH01-KS)
HFH2-Z2 Loop Antenna	R&S	HFH2-Z2	100321	9kHz~30MHz	Oct. 22, 2012	Jun. 16, 2013	Oct. 21, 2013	Radiation (03CH01-KS)
Double Ridge Horn Antenna	ETS-Lindgren	1908/7/13	00075957	1GHz~18GHz	Dec. 07, 2012	Jun. 16, 2013	Dec. 06, 2013	Radiation (03CH01-KS)
Turn Table	MF	MF7802	N/A	0~360 degree	N/A	Jun. 16, 2013	N/A	Radiation (03CH01-KS)
Antenna Mast	MF	MF7802	N/A	1 m~4 m	N/A	Jun. 16, 2013	N/A	Radiation (03CH01-KS)
Amplifier	com-power	PA-103A	161069	1MHz~1GHz	May 23, 2013	Jun. 16, 2013	May 22, 2014	Radiation (03CH01-KS)
Amplifier	Agilent	8449B	3008A02370	1GHz~26.5GHz	Dec. 29, 2012	Jun. 16, 2013	Dec. 28, 2013	Radiation (03CH01-KS)
Active Horn Antenna	com-power	AHA-118	701023	1GHz~18GHz	Nov. 07, 2012	Jun. 16, 2013	Nov. 06, 2013	Radiation (03CH01-KS)
SHF-EHF Horn	Schwarzbeck	BBHA 9170	9170249	15GHz~40GHz	Nov. 23, 2012	Jun. 16, 2013	Nov. 22, 2013	Radiation (03CH01-KS)
EMI Receiver	R&S	ESCI7	100768	9kHz~7GHz	May 31, 2013	Jun. 19, 2013	May 30, 2014	Conduction (CO01-KS)
LISN	MessTec	AN3016	60103	9kHz~30MHz	Dec. 29, 2012	Jun. 19, 2013	Dec. 28, 2013	Conduction (CO01-KS)
LISN (for auxiliary equipment)	MessTec	AN3016	60105	9kHz~30MHz	Dec. 29, 2012	Jun. 19, 2013	Dec. 28, 2013	Conduction (CO01-KS)

5 Uncertainty of Evaluation

Uncertainty of Conducted Emission Measurement (150kHz ~ 30MHz)

Measuring Uncertainty for a Level of Confidence of 95% ($U = 2Uc(y)$)	2.26
---	------

Uncertainty of Radiated Emission Measurement (30MHz ~ 1000MHz)

Measuring Uncertainty for a Level of Confidence of 95% ($U = 2Uc(y)$)	2.54
---	------

Uncertainty of Radiated Emission Measurement (1GHz ~ 40GHz)

Measuring Uncertainty for a Level of Confidence of 95% ($U = 2Uc(y)$)	4.72
---	------



Appendix A. Photographs of EUT

Please refer to Sporton report number EP361405 as below.