

Full SAR Test Report

Applicant Name: LENOVO MOBILE COMMUNICATION TECHNOLOGY LTD.
 Applicant Address: No.999, Qishan North 2nd Road, Information&Optoelectronics Park,
 Torch Hi-tech Industry Development Zone, Xiamen, P.R. China
 P.C:361006

The following samples were submitted and identified on behalf of the client as:

Sample Description	GSM Mobile Phone
SGS Ref	KL006
Model Number	A332
Final Hardware Version Tested	Q58_MB_V1.0
Final Software Version Tested	A332_ve_s0003_100512
FCC ID	YCNA332
Date Initial Sample Received	05-13,2010
Testing Start Date	05-14,2010
Testing End Date	05-20,2010

According to:
 FCC 47CFR § 2.1093, IEEE Std C95.1-2005
 IEEE1528-2003, OET Bulletin 65 Supplement C

Comments/ Conclusion:

The configuration tested complied to the certification requirements specified in this report.
 Signed for on behalf of SGS

William Wang
 Project Manager

Peter Liu
 Technical Manager

This document is issued by the Company subject to its General Conditions of Service printed overleaf, available on request or accessible at http://www.sgs.com/terms_and_conditions.htm, and, for electronic format documents to Terms and Conditions for Electronic Documents at www.sgs.com/terms_e-document.htm. Attention is drawn to the limitation of liability, indemnification and jurisdiction issues defined therein. Any holder of this document is advised that information contained hereon reflects the company's findings at the time of its intervention only and within the limits of Client's instructions, if any. The Company's sole responsibility is to its Client and this document does not exonerate parties to a transaction from exercising all their rights and obligation under the transaction documents. This document cannot be reproduced except in full, without prior written approval of the Company. Any unauthorised alteration, forgery or falsification of the content or appearance of this document is unlawful and offenders may be prosecuted to the fullest extent of the law. Unless otherwise stated the results shown in this test report refer only to the sample(s) tested and such sample(s) are retained for 30 days only

SHGSM

Table of Contents

Change History	3
1. Report Overview	4
2. Test Lab Declaration or Comments	4
3. Applicant Declaration or Comments	4
4. Full Test Report	4
5. Partial Test Report	4
6. Measurement Uncertainty	4
7. Testing Environment	6
8. Primary Test Laboratory	6
9. Details of Applicant	6
10. Details of Manufacturer	6
11. Other testing Locations	6
12. Referenced Documents	7
13. Primary Laboratory Accreditation Details	8
14. SGS Shanghai Wireless Telecommunications lab, Personnel	9
15. Test Equipment Information	10
15.1 SPEAG DASY4	10
15.2 The SAR Measurement System	11
15.3 Isotropic E-field Probe ES3DV3	12
15.4 SAM Twin Phantom	13
15.5 Device Holder for Transmitters	14
16. Detailed Test Results	15
16.1 Summary of Results	15
16.2 Maximum Results	17
16.3 Operation Configurations	17
16.4 Measurement procedure	18
16.5 Detailed Test Results	19
17. Identification of Samples	56
18. Photographs of EUT	57
Annex A Photographs of Test Setup	59
Annex B Tissue Simulant Liquid	63
Annex C SAR System Validation	64
Annex D Description of Test Position	70
Annex E Calibration certificate	73
Annex E.1 Probe Calibration certificate	73
Annex E.2 DAE Calibration certificate	84
Annex E.3 Dipole Calibration certification	89
Annex F Additional SAR Probe Validation	99
END OF REPORT	107

Change History

Version	Change Contents	Author	Date
V1.0	First edition	Tina Gong	05-24, 2010
V2.0	Add annex F, Photo and change crest factor	Willam Wang	06-09, 2010

1. Report Overview

This report details the results of testing carried out on the samples listed in section 17, the results contained in this test report do not relate to other samples of the same product. The manufacturer should ensure that all products in series production are in conformity with the product sample detailed in this report.

This report may only be reproduced and distributed in full. If the product in this test report is used in any configuration other than that detailed in the test report, the manufacturer must ensure the new configuration complies with all relevant standards and certification requirements. Any mention of SGS Shanghai Wireless Telecommunications lab or testing done by SGS Shanghai Wireless Telecommunications lab made in connection with the distribution or use of the tested product must be approved in writing by SGS Shanghai Wireless Telecommunications lab.

2. Test Lab Declaration or Comments

None

3. Applicant Declaration or Comments

None

4. Full Test Report

A full test report contains, within the results section, all the applicable test cases from the certification requirements of the permanent reference documents of the listed certification bodies.

5. Partial Test Report

A partial test report contains within the results section a sub-set of all the applicable test cases from the certification requirements of the permanent reference documents of the listed certification bodies.

6. Measurement Uncertainty

Measurements and results are all in compliance with the standards listed in section 12 of this report. All measurements and results are recorded and maintained at the laboratory performing the tests and measurement uncertainties are taken into account when comparing measurements to pass/ fail criteria.

a	b1	c	d	e = f(d,k)	g	i = cxg/e	k
Uncertainty Component	Section in P1528	Tol (%)	Prob . Dist.	Div.	Ci (1g)	1g ui (%)	Vi (Veff)
Probe calibration	E.2.1	6.3	N	1	1	6.3	∞
Axial isotropy	E.2.2	0.5	R	$\sqrt{3}$	$(1-c_p)^{1/2}$	0.20	∞
hemispherical isotropy	E.2.2	2.6	R	$\sqrt{3}$	$\sqrt{c_p}$	1.06	∞
Boundary effect	E.2.3	0.8	R	$\sqrt{3}$	1	0.46	∞
Linearity	E.2.4	0.6	R	$\sqrt{3}$	1	0.35	∞
System detection limit	E.2.5	0.25	R	$\sqrt{3}$	1	0.15	∞
Readout electronics	E.2.6	0.3	N	1	1	0.3	∞
Response time	E.2.7	0	R	$\sqrt{3}$	1	0	∞
Integration time	E.2.8	2.6	R	$\sqrt{3}$	1	1.5	∞
RF ambient Condition -Noise	E.6.1	3	R	$\sqrt{3}$	1	1.73	∞
RF ambient Condition - reflections	E.6.1	3	R	$\sqrt{3}$	1	1.73	∞
Probe positioning- mechanical tolerance	E.6.2	1.5	R	$\sqrt{3}$	1	0.87	∞
Probe positioning- with respect to phantom	E.6.3	2.9	R	$\sqrt{3}$	1	1.67	∞
Max. SAR evaluation	E.5.2	1	R	$\sqrt{3}$	1	0.58	∞
Test sample positioning	E.4.2	4	N	1	1	3.7	9
Device holder uncertainty	E.4.1	3.6	N	1	1	3.6	∞
Output power variation -SAR drift measurement	6.62	5	R	$\sqrt{3}$	1	2.89	∞
Phantom uncertainty (shape and thickness tolerances)	E.3.1	4	R	$\sqrt{3}$	1	2.31	∞
Liquid conductivity - deviation from target values	E.3.2	5	R	$\sqrt{3}$	0.64	1.85	∞
Liquid conductivity - measurement uncertainty	E.3.2	4	N	1	0.64	2.56	5
Liquid permittivity - deviation from target values	E.3.3	5	R	$\sqrt{3}$	0.6	1.73	∞
Liquid permittivity - measurement uncertainty	E.3.3	4	N	1	0.6	2.40	5
Combined standard uncertainty				RSS		10.71	430
Expanded uncertainty (95% CONFIDENCE INTERVAL)				K=2		21.43	

7. Testing Environment

Normal Temperature	+20 to +24 °C
Relative Humidity	35 to 60 %

8. Primary Test Laboratory

Name:	Wireless Telecommunications Laboratory SGS-CSTC Standards Technical Services(Shanghai) Co., Ltd
Address:	9F, 3rd Building, No.889, Yishan Rd, Xuhui District, Shanghai, China 200233
Telephone:	+86 (0) 21 6140 2666
Fax:	+86 (0) 21 5450 0149
Internet:	http://www.cn.sgs.com
Contact:	Mr. Peter Xue
Email:	peter.xue@sgs.com

9. Details of Applicant

Name:	LENOVO MOBILE COMMUNICATION TECHNOLOGY LTD.
Address:	No.999,Qishan North 2nd Road,Information&Optoelectronics Park,Torch Hi-tech Industry Development Zone,Xiamen,P.R.China P.C:361006
Telephone:	+86 592-216 6651
Contact:	Qiushou yu
Fax	+86 592-216 6651
Email:	qiusya@lenovomobile.com

10. Details of Manufacturer

Name:	LENOVO MOBILE COMMUNICATION TECHNOLOGY LTD.
Address:	No.999,Qishan North 2nd Road,Information&Optoelectronics Park,Torch Hi-tech Industry Development Zone,Xiamen,P.R.China P.C:361006
Telephone:	+86 592-216 6651
Contact:	Qiushou yu
Fax	+86 592-216 6651
Email:	qiusya@lenovomobile.com

11. Other testing Locations

Name:	Not Required
Address:	--
Telephone:	--
Contact:	--
Fax	--
Email:	--

12. Referenced Documents

The Equipment under Test (EUT) has been tested at SGS's (own or subcontracted) laboratories according to FCC 47CFR § 2.1093, IEEE Std C95.1-2005, IEEE1528-2003, OET Bulletin 65 Supplement C

The following table summarizes the specific reference documents such as harmonized standards or test specifications which were used for testing as SGS's (own or subcontracted) laboratories.

Identity	Document Title	Version
FCC 47CFR § 2.1093	Radiofrequency radiation exposure evaluation:portable devices	2001
IEEE Std C95.1-2005	IEEE Standard for Safety Levels with Respect to Human Exposure to Radio Frequency Electromagnetic Fields, 3 kHz to 300 GHz.	2005
IEEE1528-2003	IEEE Recommended Practice for Determining the Peak Spatial-Average Specific Absorption Rate (SAR) in the Human Head from Wireless Communications Devices: Measurement Techniques	2003
OET Bulletin 65 Supplement C	Additional Information for Evaluating Compliance of Mobile and Portable Devices with FCC Limits for Human Exposure to Radiofrequency Emissions	2001
KDB 648474 D01	SAR Evaluation Considerations for Handsets with Multiple Transmitters and Antennas	-
KDB 941225 D03	Recommended SAR Test Reduction Procedures for GSM/GPRS/EDGE	-

Human Exposure	Uncontrolled Environment General Population
Spatial Peak SAR	1.60 W/kg (averaged over a mass of 1g)

Table 12-1 RF Exposure Limits

Notes:

1. Uncontrolled environments are defined as locations where there is potential exposure of individuals who have no knowledge or control of their potential exposure.

13. Primary Laboratory Accreditation Details



SHGSM

14. SGS Shanghai Wireless Telecommunications lab, Personnel

SGS Wireless Shanghai Project Management Team and list of approved Testers for SGS Wireless Shanghai.

Surname	Forename	Initials
CAI	CAI	CAICAI
Xue	Peter	PETERXUE
Xu	Anya	ANYA
Ni	Lemon	LEMONNI
Tao	Kevin	KEVINTAO
Wang	Lawrence	LAWRENCE
Zhang	Sean	SEANZH
Ruan	Roger	ROGER
Zhang	Zenger	ZENGER
Tang	Eva	EVATANG
Ho	James	JAMESHO
Tang	Kenny	KENNY
Hailiang	Cai	HAILIANG
Chan	Hik Kwong	HKC
Nie	Neo	Neo
Gong	Tina	TINA
Nie	Marina	MARINA
Xu	Jesse	JESSE
Wang	Willam	WILLAM

Version 2010-05-18

15. Test Equipment Information

15.1 SPEAG DASY4

Test Platform	SPEAG DASY4 Professional			
Location	SGS SH Lab #8			
Manufacture	SPEAG			
Description	SAR Test System (Frequency range 300MHz-3GHz) 835, 900, 1800, 1900, 2000, 2450 frequency band HAC Extension			
Software Reference	DASY4: V4.7 Build 80 SEMCAD: V1.8 Build 186			
Hardware Reference				
Equipment	Model	Serial Number	Calibration Date	Due date of calibration
Robot	RX90L	F03/5V32A1/A01	n/a	n/a
Phantom	SAM 12	TP-1283	n/a	n/a
DAE	DAE3	569	2009-11-18	2010-11-17
E-Field Probe	ES3DV3	3088	2009-11-19	2010-11-18
Validation Kits	D835V2	4d070	2008-12-15	2010-12-14
Validation Kits	D1900V2	5d028	2009-11-24	2011-11-23
Agilent Network Analyzer	E5071B	MY42100549	2009-11-25	2010-11-24
RF Bi-Directional Coupler	ZABDC20-252H	n/a	2010-05-21	2011-05-20
Agilent Signal Generator	E4438C	14438CATO-19719	2009-11-30	2010-11-29
Mini-Circuits Preamplifier	ZHL-42	D041905	2009-11-30	2010-11-29
Agilent Power Meter	E4416A	GB41292095	2009-11-25	2010-11-24
Agilent Power Sensor	8481H	MY41091234	2009-11-25	2010-11-24
R&S Power Sensor	NRP-Z92	100025	2010-04-12	2011-04-11
R&S Universal Radio Communication Tester	CMU200	103633	2009-11-26	2010-11-25

15.2 The SAR Measurement System

A photograph of the SAR measurement System is given in Fig. 15-1.

This SAR Measurement System uses a Computer-controlled 3-D stepper motor system (Speag Dasy 4 professional system). A Model ES3DV3 3088 E-field probe is used to determine the internal electric fields. The SAR can be obtained from the equation $SAR = \sigma (|E|^2) / \rho$ where σ and ρ are the conductivity and mass density of the tissue-simulant.

The DASY4 system for performing compliance tests consists of the following items:

A standard high precision 6-axis robot (Stabile RX family) with controller, teach pendant and software. An arm extension for accommodation the data acquisition electronics (DAE).

A dosimetric probe, i.e., an isotropic E-field probe optimized and calibrated for usage in tissue simulating liquid. The probe is equipped with an optical surface detector system.

A data acquisition electronics (DAE) which performs the signal amplification, signal multiplexing, AD-conversion, offset measurements, mechanical surface detection, collision detection, etc. The unit is battery powered with standard or rechargeable batteries. The signal is optically transmitted to the EOC.

The Electro-optical converter (EOC) performs the conversion between optical and electrical of the signals for the digital communication to DAE and for the analog signal from the optical surface detection. The EOC is connected to the measurement server.

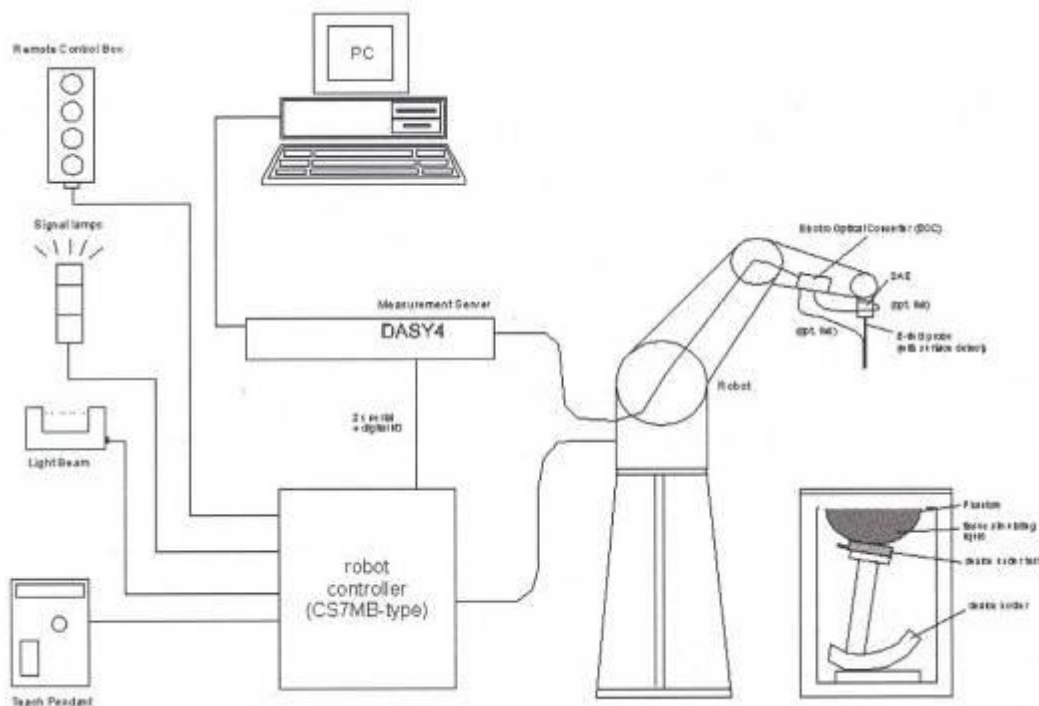

Fig. 15-1 SAR System Configuration

- Y The function of the measurement server is to perform the time critical tasks such as signal filtering, control of the robot operation and fast movement interrupts.
- Y A probe alignment unit which improves the (absolute) accuracy of the probe positioning.
- Y A computer operating Windows 2000.

- ÿ DASY4 software.
- ÿ Remote control with teach pendant and additional circuitry for robot safety such as warning lamps, etc.
- ÿ The SAM twin phantom enabling testing left-hand, right-hand and BodyWorn usage.
- ÿ The device holder for handheld mobile phones.
- ÿ Tissue simulating liquid mixed according to the given recipes.
- ÿ Validation dipole kits allowing to validating the proper functioning of the system

15.3 Isotropic E-field Probe ES3DV3

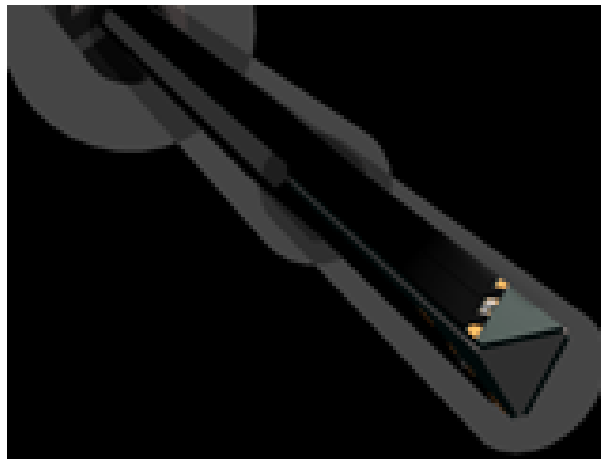

Fig. 15-2 E-field Probe

Construction	Symmetrical design with triangular core Interleaved sensors Built-in shielding against static charges PEEK enclosure material (resistant to organic solvents, e.g., DGBE)
Calibration	Basic Broad Band Calibration in air Conversion Factors (CF) for HSL 900 and HSL 1810 Additional CF for other liquids and frequencies upon request
Frequency	10 MHz to 4 GHz; Linearity: ± 0.2 dB (30 MHz to 4 GHz)
Directivity	± 0.2 dB in HSL (rotation around probe axis) ± 0.3 dB in tissue material (rotation normal to probe axis)
Dynamic Range	5 μ W/g to > 100 mW/g; Linearity: ± 0.2 dB
Dimensions	Overall length: 330 mm (Tip: 20 mm) Tip diameter: 3.9 mm (Body: 12 mm) Distance from probe tip to dipole centers: 2.0 mm
Application	General dosimetry up to 4 GHz Dosimetry in strong gradient fields Compliance tests of mobile phones

15.4 SAM Twin Phantom



Fig. 15-3 SAM Twin Phantom

The SAM twin phantom is a fiberglass shell phantom with 2mm shell thickness (except the ear region where shell thickness increases to 6mm). It has three measurement areas:

- Left hand
- Right hand
- Flat phantom

A white cover is provided to tap the phantom during off-periods to prevent water evaporation and changes in the liquid parameters. Free space scans of devices on the cover are possible.

On the phantom top, three reference markers are provided to identify the phantom position with respect to the robot.

Phantom specification:

Description	The shell corresponds to the specifications of the Specific Anthropomorphic Mannequin (SAM) phantom defined in IEEE 1528-2003, CENELEC 50361 and IEC 62209. It enables the dosimetric evaluation of left and right hand phone usage as well as body mounted usage at the flat phantom region. A cover prevents evaporation of the liquid. Reference markings on the phantom allow the complete setup of all predefined phantom positions and measurement grids by teaching three points with the robot.
Shell Thickness	2+0.2mm, Center ear point: 6+0.2mm
Filling Volume	Approx.25 liters
Dimensions	Length: 1000mm, Width: 500mm, Height: 850mm

15.5 Device Holder for Transmitters



Fig. 15-4 Device Holder for Transmitters

The SAR in the phantom is approximately inversely proportional to the square of the distance between the source and the liquid surface. For a source in 5mm distance, a positioning uncertainty of $\pm 0.5\text{mm}$ would produce a SAR uncertainty of $\pm 20\%$. An accurate device positioning is therefore crucial for accurate and repeatable measurements. The positions, in which the devices must be measured, are defined by the standards.

The DASY device holder is designed to cope with different positions given in the standard. It has two scales for the device rotation (with respect to the body axis) and the device inclination (with respect to the line between the ear reference points). The rotation centers for both scales are the ear reference point (ERP). Thus the device needs no repositioning when changing the angles.

The DASY device holder has been made out of low-loss POM material having the following dielectric parameters: relative permittivity $\epsilon_r=3$ and loss tangent $\tan \delta=0.02$. The amount of dielectric material has been reduced in the closest vicinity of the device, since measurements have suggested that the influence of the clamp on the test results could thus be lowered.

16. Detailed Test Results

16.1 Summary of Results

16.1.1 Measurement of RF conducted Power

Unit: dBm

Mode		GPRS				EGPRS								GSM
Slot (Uplink)		1	2	3	4	1		2		3		4		-
Band	Channel	GMSK				GMSK	8PSK	GMSK	8PSK	GMSK	8PSK	GMSK	8PSK	-
850	128	31.9	31.9	--	--	--	--	--	--	--	--	--	--	32
	190	32.1	32.1	--	--	--	--	--	--	--	--	--	--	31.5
	251	31.8	31.8	--	--	--	--	--	--	--	--	--	--	31.8
1900	512	29.1	29.1	--	--	--	--	--	--	--	--	--	--	29.1
	661	29.3	29.3	--	--	--	--	--	--	--	--	--	--	29.3
	810	29.2	29.2	--	--	--	--	--	--	--	--	--	--	29.3

16.1.2 Measurement of SAR average value

GSM 850

Band	EUT Position	Mode	Test Configuration	Averaged SAR over 1g (W/kg)			SAR limit 1g (W/kg)	Verdict
				CH128	CH190	CH251		
				824.2MHz	836.6MHz	848.8MHz		
GSM850	Left	GSM	Cheek	0.800	0.843	0.794	1.6	Passed
			Tilt	--	0.475	--	1.6	Passed
			Cheek With memory	--	0.869	--	1.6	Passed
	Right		Cheek	0.854	0.901	0.840	1.6	Passed
			Tilt	--	0.492	--	1.6	Passed
			Cheek With memory	--	0.913	--	1.6	Passed
	Body Worn	GPRS (1 slot uplink)	Front of EUT facing phantom	--	0.527	--	1.6	Passed
			Rear of EUT facing phantom	--	0.606	--	1.6	Passed
		GPRS (2 slot uplink)	Rear of EUT facing phantom	1.16	1.16	1.0	1.6	Passed
			Front of EUT facing phantom	--	1.03	--	1.6	Passed
GPRS (2 slot uplink)		Rear of EUT facing phantom With headset	1.16	--	--	1.6	Passed	

SHGSM

			Rear of EUT facing phantom With memory	1.16	--	--	1.6	Passed
--	--	--	---	------	----	----	-----	--------

PCS1900

Band	EUT Position	Mode	Test Configuration	Averaged SAR over 1g / 10g (W/kg)			SAR limit 1g (W/kg)	Verdict
				CH512	CH661	CH810		
				1850.2MHz	1880MHz	1909.8MHz		
PCS1900	Left	GSM	Cheek	1.07	0.998	0.866	1.6	Passed
			Tilt	--	0.277	--	1.6	Passed
			Cheek With memory	1.06	--	--	1.6	Passed
	Right		Cheek	0.723	0.702	0.665	1.6	Passed
			Tilt	--	0.176	--	1.6	Passed
			Cheek With memory	0.725	--	--	1.6	Passed
	Body Worn	GPRS (1 slot uplink)	Rear of EUT facing phantom	--	0.451	--	1.6	Passed
			Rear of EUT facing phantom	0.864	0.764	0.773	1.6	Passed
		GPRS (2 slot uplink)	Front of EUT facing phantom	--	0.459	--	1.6	Passed
			Rear of EUT facing phantom With headset	0.737	--	--	1.6	Passed
			Rear of EUT facing phantom With memory	0.751	--	--	1.6	Passed

16.2 Maximum Results

The maximum measured SAR values for Head configuration and BodyWorn configuration are given in section 16.2.1 and 16.2.2 respectively.

16.2.1 Head Configuration

Frequency Band	EUT Position	Conducted Power (dBm)	SAR, Averaged over 1g (W/kg)	Power Drift (dB)	SAR limit (W/kg)	Verdict
GSM850	Right/Cheek/Mid With Bluetooth	31.5	0.917	-0.0434	1.6	Passed
PCS1900	Left/Cheek/Low	29.1	1.07	-0.035	1.6	Passed

16.2.2 BodyWorn Configuration

Frequency Band	EUT Position	Conducted Power (dBm)	SAR, Averaged over 1g (W/kg)	Power Drift (dB)	SAR limit (W/kg)	Verdict
GSM850	GPRS/2slot uplink/Rear/Low	31.9	1.16	-0.0695	1.6	Passed
PCS1900	GPRS/2slot uplink/Rear/Low	29.1	0.864	0.135	1.6	Passed

16.2.3 Maximum Drift

Maximum Drift during measurement	0.142
----------------------------------	-------

16.2.4 Measurement Uncertainty

Extended Uncertainty (k=2) 95%	21.43%
--------------------------------	--------

16.3 Operation Configurations

The EUT is controlled by using a radio communication tester (CMU200) with air link, and the EUT is set to maximum output power by CMU200 during all tests.

The tests in the band of GSM850, PCS1900 are performed in the GSM/GPRS mode.

1. Testing Head SAR at GSM mode for all bands with Left Cheek/Tilt and Right Cheek/Tilt conditions.
2. Testing Body SAR at GPRS mode for all bands by separating 1.5cm from the EUT (both front and rear) to flat phantom.
3. Body SAR at GPRS, EGPRS modes for all bands with front and rear of EUT facing to the phantom should be done.
4. Head and Body SAR with accessories should be done at worstcase to identify maximum SAR value.
5. Test reduction has been adopted according to conducted output power and produced SAR level:

SHGSM

Low and High channel SAR are optional if SAR value produced in the middle channel is 3dB lower than the applicable SAR limit;

In GPRS mode, the multislot configuration which produces highest SAR value is regard as the worst case to be measured, other multislot configurations are selectively confirmed;

6. In EGPRS mode, the test is in the GMSK modulation according to the power between GMSK and 8PSK.

The maximum output power of EGPRS, GMSK mode is the same as the GPRS mode. So the EGPRS mode SAR evaluation is optional.

7. The (max.cube) labeling indicates that during the grid scanning an additional peak was found which within 2dB of the highest peak

8. Bluetooth: the maximum output power is below Pref/12mw, stand alone SAR evaluation is not required.so the simultaneous transmission is not required.

9. Head SAR for GSM should be tested in GPRS/EGPRS modes, if EUT support DTM.

16.4 Measurement procedure

Step 1: Power reference measurement

The SAR measurement was taken at a selected spatial reference point to monitor power variations during testing. This fixed location point was measured and used as a reference value.

Step 2: Area scan

The SAR distribution at the exposed side of the head was measured at a distance of 4mm from the inner surface of the shell. The area covered the entire dimension of the head and the horizontal grid spacing was 15mm*15mm or 10mm*10mm. Based on the area scan data, the area of the maximum absorption was determined by spline interpolation.

Step 3: Zoom scan

Around this point, a volume of 30mm*30mm*30mm (fine resolution volume scan, zoom scan) was assessed by measuring 7*7*7 points. On this basis of this data set, the spatial peak SAR value was evaluated with the following procedure:

The data at the surface was extrapolated, since the center of the dipoles is 2.0mm away from the tip of the probe and the distance between the surface and the lowest measuring point is 1.2mm. (This can be variable. Refer to the probe specification). The extrapolation was based on a least square algorithm. A polynomial of the fourth order was calculated through the points in z-axes. This polynomial was then used to evaluate the points between the surface and the probe tip. The maximum interpolated value was searched with a straight-forward algorithm. Around this maximum the SAR values averaged over the spatial volumes (1g or 10g) were computed using the 3D-Spline interpolation algorithm. The volume was integrated with the trapezoidal algorithm. One thousand points (10*10*10) were interpolated to calculate the average. All neighboring volumes were evaluated until no neighboring volume with a higher average value was found.

Step 4: Power reference measurement (drift)

The SAR value at the same location as in step 1 was again measured. (If the value changed by more than 5%, the evaluation should be done repeatedly)

16.5 Detailed Test Results

16.5.1 GSM850-LeftHandSide-Tilt-Middle

Date/Time: 2010-5-14 9:14:17

Test Laboratory: SGS-GSM

GSM850-LeftHandSide-Tilt-Mid

DUT: KL006; Type: Head&Body; Serial: 35519200110001178

Communication System: GSM850-GSM Mode; Frequency: 836.6 MHz; Duty Cycle: 1:8.3

Medium: HSL835_Head Medium parameters used: $f = 836.6$ MHz; $\sigma = 0.895$ mho/m; $\epsilon_r = 42.5$; $\rho = 1000$ kg/m³

Phantom section: Left Section

DASY4 Configuration:

- Probe: ES3DV3 - SN3088; ConvF(5.84, 5.84, 5.84); Calibrated: 2009-11-19
- Sensor-Surface: 4mm (Mechanical Surface Detection)
- Electronics: DAE3 Sn569; Calibrated: 2009-11-18
- Phantom: SAM 12; Type: SAM V4.0; Serial: TP-1283
- Measurement SW: DASY4, V4.7 Build 80; Postprocessing SW: SEMCAD, V1.8 Build 186

Tilt position - Mid/Area Scan (61x91x1): Measurement grid: dx=15mm, dy=15mm

Maximum value of SAR (interpolated) = 0.499 mW/g

Tilt position - Mid/Zoom Scan (7x7x7) (7x7x7)/Cube 0: Measurement grid: dx=5mm, dy=5mm, dz=5mm

Reference Value = 17.8 V/m; Power Drift = 0.012 dB

Peak SAR (extrapolated) = 0.640 W/kg

SAR(1 g) = 0.475 mW/g; SAR(10 g) = 0.341 mW/g

Maximum value of SAR (measured) = 0.502 mW/g

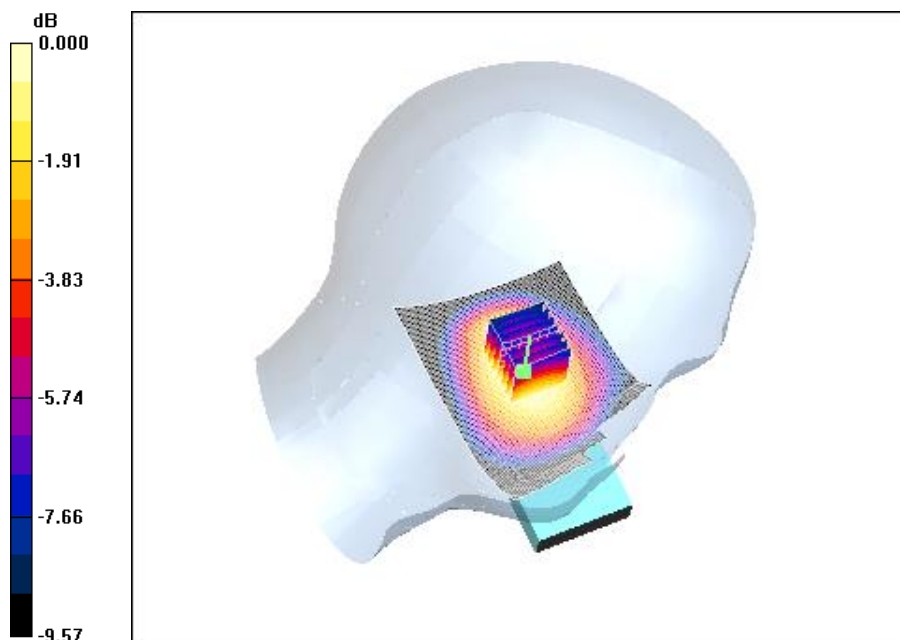

0 dB = 0.502mW/g

SHGSM

16.5.2 GSM850-LeftHandSide-Cheek-Middle

Date/Time: 2010-5-14 9:40:21

Test Laboratory: SGS-GSM

GSM850-LeftHandSide-Touch-Mid

DUT: KL006; Type: Head&Body; Serial: 35519200110001178

Communication System: GSM850-GSM Mode; Frequency: 836.6 MHz; Duty Cycle: 1:8.3

Medium: HSL835_Head Medium parameters used: $f = 836.6$ MHz; $\sigma = 0.895$ mho/m; $\epsilon_r = 42.5$; $\rho = 1000$ kg/m³

Phantom section: Left Section

DASY4 Configuration:

- Probe: ES3DV3 - SN3088; ConvF(5.84, 5.84, 5.84); Calibrated: 2009-11-19
- Sensor-Surface: 4mm (Mechanical Surface Detection)
- Electronics: DAE3 Sn569; Calibrated: 2009-11-18
- Phantom: SAM 12; Type: SAM V4.0; Serial: TP-1283
- Measurement SW: DASY4, V4.7 Build 80; Postprocessing SW: SEMCAD, V1.8 Build 186

Cheek position - Mid/Area Scan (61x101x1): Measurement grid: dx=15mm, dy=15mm

Maximum value of SAR (interpolated) = 0.892 mW/g

Cheek position - Mid/Zoom Scan (7x7x7) (7x7x7)/Cube 0: Measurement grid: dx=5mm, dy=5mm, dz=5mm

Reference Value = 13.1 V/m; Power Drift = -0.018 dB

Peak SAR (extrapolated) = 1.10 W/kg

SAR(1 g) = 0.843 mW/g; SAR(10 g) = 0.604 mW/g

Maximum value of SAR (measured) = 0.884 mW/g

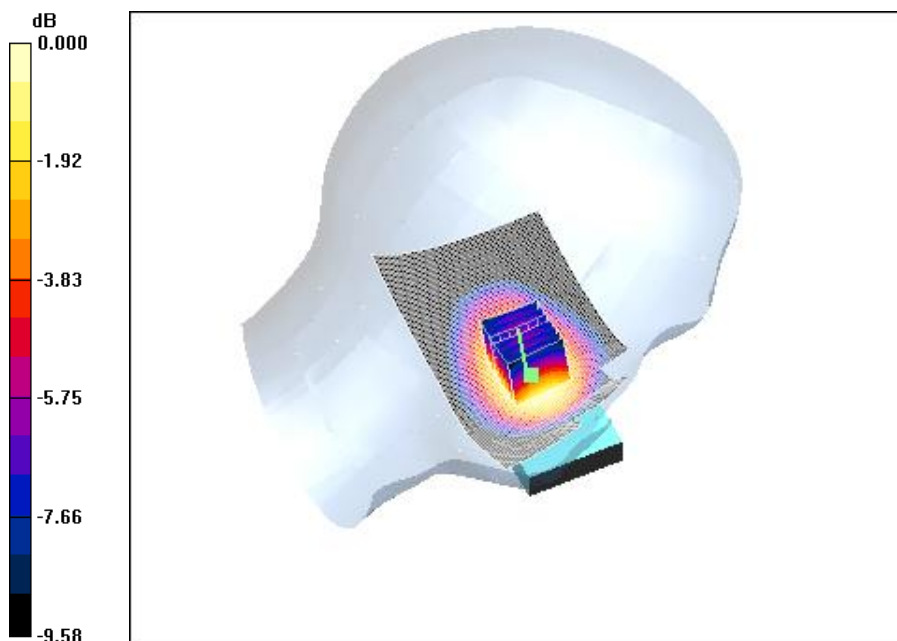

0 dB = 0.884mW/g

SHGSM

16.5.3 GSM850-LeftHandSide-Cheek-Low

Date/Time: 2010-5-14 10:06:10

Test Laboratory: SGS-GSM

GSM850-LeftHandSide-Touch-Low

DUT: KL006; Type: Head&Body; Serial: 35519200110001178

Communication System: GSM850-GSM Mode; Frequency: 824.2 MHz;Duty Cycle: 1:8.3

Medium: HSL835_Head Medium parameters used: f = 824.2 MHz; $\sigma = 0.884$ mho/m; $\epsilon_r = 42.6$; $\rho = 1000$ kg/m³

Phantom section: Left Section

DASY4 Configuration:

- Probe: ES3DV3 - SN3088; ConvF(5.84, 5.84, 5.84); Calibrated: 2009-11-19
- Sensor-Surface: 4mm (Mechanical Surface Detection)
- Electronics: DAE3 Sn569; Calibrated: 2009-11-18
- Phantom: SAM 12; Type: SAM V4.0; Serial: TP-1283
- Measurement SW: DASY4, V4.7 Build 80; Postprocessing SW: SEMCAD, V1.8 Build 186

Cheek position - Low/Area Scan (61x101x1): **Measurement grid: dx=15mm, dy=15mm**

Maximum value of SAR (interpolated) = 0.855 mW/g

Cheek position - Low/Zoom Scan (7x7x7) (7x7x7)/Cube 0: **Measurement grid: dx=5mm, dy=5mm, dz=5mm**

Reference Value = 12.9 V/m; Power Drift = -0.023 dB

Peak SAR (extrapolated) = 1.05 W/kg

SAR(1 g) = 0.800 mW/g; SAR(10 g) = 0.576 mW/g

Maximum value of SAR (measured) = 0.851 mW/g

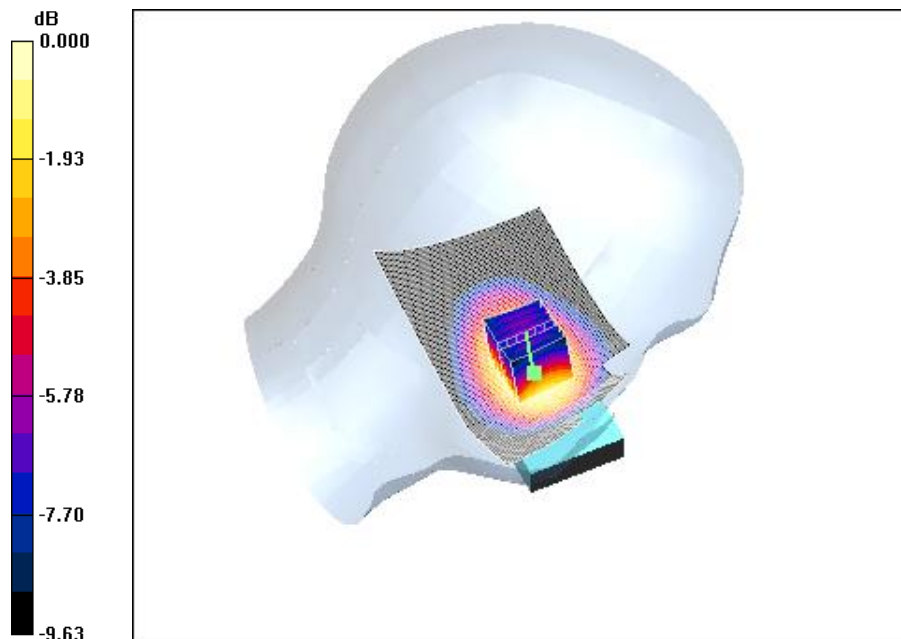

0 dB = 0.851mW/g

SHGSM

16.5.4 GSM850-LeftHandSide-Cheek-High

Date/Time: 2010-5-14 10:46:03

Test Laboratory: SGS-GSM

GSM850-LeftHandSide-Touch-High

DUT: KL006; Type: Head&Body; Serial: 35519200110001178

Communication System: GSM850-GSM Mode; Frequency: 848.8 MHz;Duty Cycle: 1:8.3

Medium: HSL835Head Medium parameters used: $f = 848.8 \text{ MHz}$; $\sigma = 0.906 \text{ mho/m}$; $\epsilon_r = 42.3$; $\rho = 1000 \text{ kg/m}^3$

Phantom section: Left Section

DASY4 Configuration:

- Probe: ES3DV3 - SN3088; ConvF(5.84, 5.84, 5.84); Calibrated: 2009-11-19
- Sensor-Surface: 4mm (Mechanical Surface Detection)
- Electronics: DAE3 Sn569; Calibrated: 2009-11-18
- Phantom: SAM 12; Type: SAM V4.0; Serial: TP-1283
- Measurement SW: DASY4, V4.7 Build 80; Postprocessing SW: SEMCAD, V1.8 Build 186

Cheek position -High/Area Scan (61x101x1): **Measurement grid: $dx=15\text{mm}$, $dy=15\text{mm}$**

Maximum value of SAR (interpolated) = 0.847 mW/g

Cheek position -High/Zoom Scan (7x7x7) (7x7x7)/Cube 0: **Measurement grid: $dx=5\text{mm}$, $dy=5\text{mm}$, $dz=5\text{mm}$**

Reference Value = 13.8 V/m; Power Drift = -0.028 dB

Peak SAR (extrapolated) = 1.02 W/kg

SAR(1 g) = 0.794 mW/g; SAR(10 g) = 0.571 mW/g

Maximum value of SAR (measured) = 0.837 mW/g

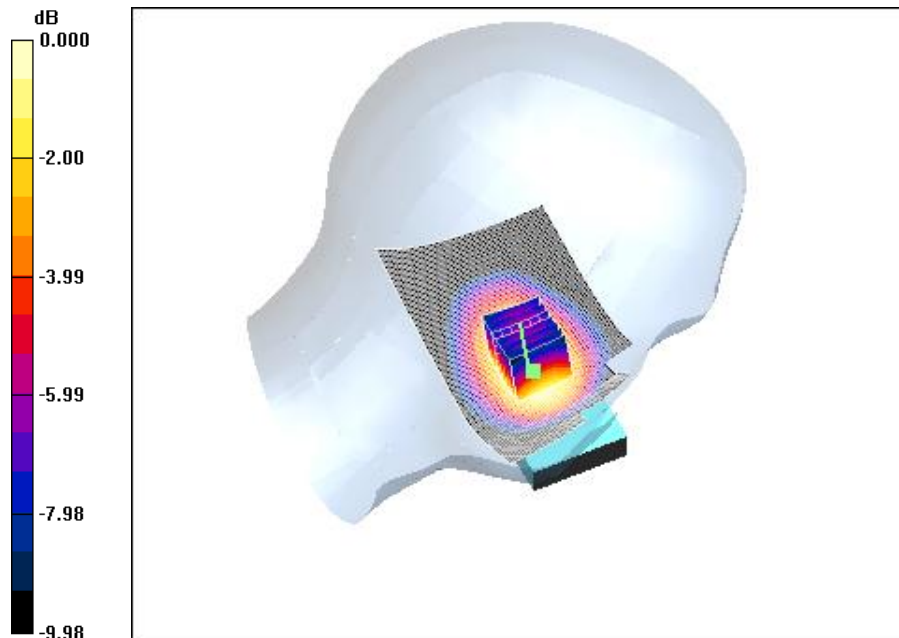

0 dB = 0.837mW/g

16.5.5 GSM850-LeftHandSide-Worstcase-With Memory

Date/Time: 2010-5-14 11:12:08

Test Laboratory: SGS-GSM

GSM850-LeftHandSide-Touch-Mid With Memory

DUT: KL006; Type: Head&Body; Serial: 35519200110001178

Communication System: GSM850-GSM Mode; Frequency: 836.6 MHz;Duty Cycle: 1:8.3

Medium: HSL835Head Medium parameters used: $f = 836.6 \text{ MHz}$; $\sigma = 0.895 \text{ mho/m}$; $\epsilon_r = 42.5$; $\rho = 1000 \text{ kg/m}^3$

Phantom section: Left Section

DASY4 Configuration:

- Probe: ES3DV3 - SN3088; ConvF(5.84, 5.84, 5.84); Calibrated: 2009-11-19
- Sensor-Surface: 4mm (Mechanical Surface Detection)
- Electronics: DAE3 Sn569; Calibrated: 2009-11-18
- Phantom: SAM 12; Type: SAM V4.0; Serial: TP-1283
- Measurement SW: DASY4, V4.7 Build 80; Postprocessing SW: SEMCAD, V1.8 Build 186

Cheek position -Mid With Memory/Area Scan (61x101x1): **Measurement grid: dx=15mm, dy=15mm**

Maximum value of SAR (interpolated) = 0.924 mW/g

Cheek position -Mid With Memory/Zoom Scan (7x7x7) (7x7x7)/Cube 0: **Measurement grid: dx=5mm, dy=5mm, dz=5mm**

Reference Value = 14.3 V/m; Power Drift = 0.042 dB

Peak SAR (extrapolated) = 1.12 W/kg

SAR(1 g) = 0.869 mW/g; SAR(10 g) = 0.625 mW/g

Maximum value of SAR (measured) = 0.912 mW/g

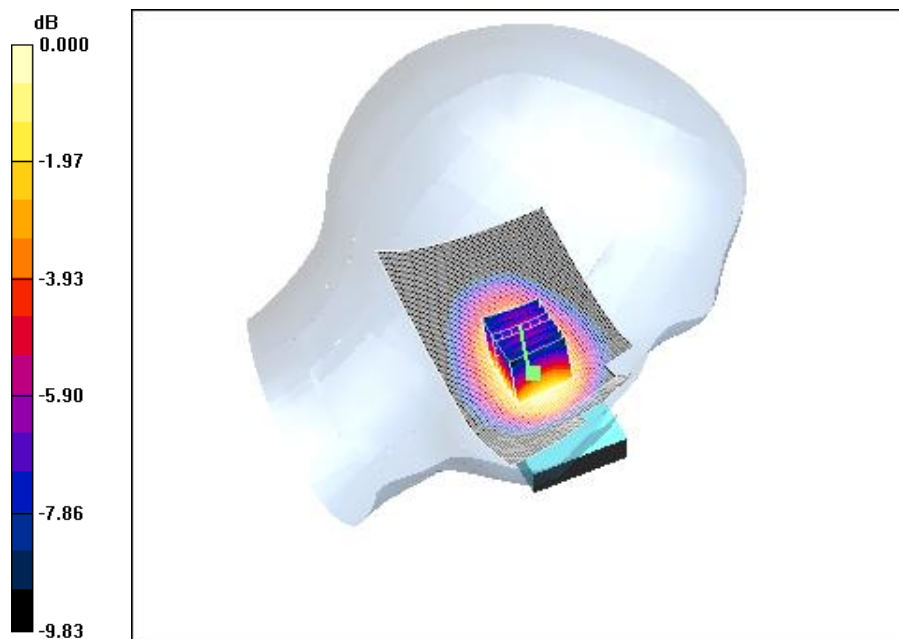

0 dB = 0.912mW/g

SHGSM

16.5.6 GSM850-RightHandSide-Cheek-Middle

Date/Time: 2010-5-14 12:08:51

Test Laboratory: SGS-GSM

GSM850-RightHandSide-Touch-Mid

DUT: KL006; Type: Head&Body; Serial: 35519200110001178

Communication System: GSM850-GSM Mode; Frequency: 836.6 MHz;Duty Cycle: 1:8.3

Medium: HSL835_Head Medium parameters used: f = 836.6 MHz; $\sigma = 0.895$ mho/m; $\epsilon_r = 42.5$; $\rho = 1000$ kg/m³

Phantom section: Right Section

DASY4 Configuration:

- Probe: ES3DV3 - SN3088; ConvF(5.84, 5.84, 5.84); Calibrated: 2009-11-19
- Sensor-Surface: 4mm (Mechanical Surface Detection)
- Electronics: DAE3 Sn569; Calibrated: 2009-11-18
- Phantom: SAM 12; Type: SAM V4.0; Serial: TP-1283
- Measurement SW: DASY4, V4.7 Build 80; Postprocessing SW: SEMCAD, V1.8 Build 186

Cheek position - Middle/Area Scan (61x111x1): **Measurement grid: dx=15mm, dy=15mm**

Maximum value of SAR (interpolated) = 0.954 mW/g

Cheek position - Middle/Zoom Scan (7x7x7)/Cube 0: **Measurement grid: dx=5mm, dy=5mm, dz=5mm**

Reference Value = 15.7 V/m; Power Drift = -0.047 dB

Peak SAR (extrapolated) = 1.18 W/kg

SAR(1 g) = 0.901 mW/g; SAR(10 g) = 0.648 mW/g

Maximum value of SAR (measured) = 0.956 mW/g

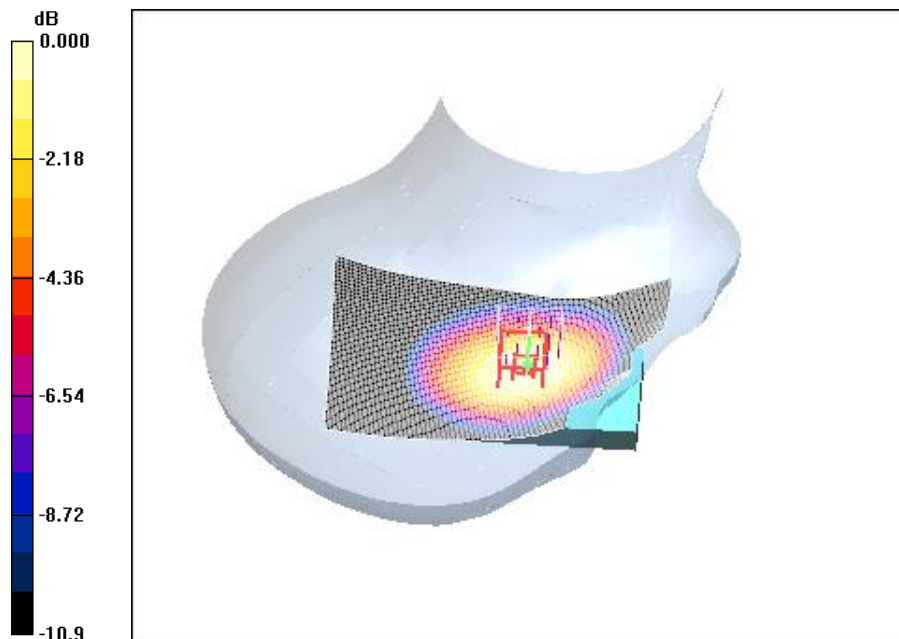

0 dB = 0.956mW/g

SHGSM

16.5.7 GSM850-RightHandSide-Tilt-Middle

Date/Time: 2010-5-14 14:15:26

Test Laboratory: SGS-GSM

GSM850-RightHandSide-Tilt-Mid

DUT: KL006; Type: Head&Body; Serial: 35519200110001178

Communication System: GSM850-GSM Mode; Frequency: 836.6 MHz;Duty Cycle: 1:8.3

Medium: HSL835_Head Medium parameters used: f = 836.6 MHz; σ = 0.895 mho/m; ϵ_r = 42.5; ρ = 1000 kg/m³

Phantom section: Right Section

DASY4 Configuration:

- Probe: ES3DV3 - SN3088; ConvF(5.84, 5.84, 5.84); Calibrated: 2009-11-19
- Sensor-Surface: 4mm (Mechanical Surface Detection)
- Electronics: DAE3 Sn569; Calibrated: 2009-11-18
- Phantom: SAM 12; Type: SAM V4.0; Serial: TP-1283
- Measurement SW: DASY4, V4.7 Build 80; Postprocessing SW: SEMCAD, V1.8 Build 186

Tilt position - Middle/Area Scan (61x91x1): **Measurement grid: dx=15mm, dy=15mm**

Maximum value of SAR (interpolated) = 0.524 mW/g

Tilt position - Middle/Zoom Scan (7x7x7)/Cube 0: **Measurement grid: dx=5mm, dy=5mm, dz=5mm**

Reference Value = 17.9 V/m; Power Drift = 0.009 dB

Peak SAR (extrapolated) = 0.652 W/kg

SAR(1 g) = 0.492 mW/g; SAR(10 g) = 0.356 mW/g

Maximum value of SAR (measured) = 0.522 mW/g

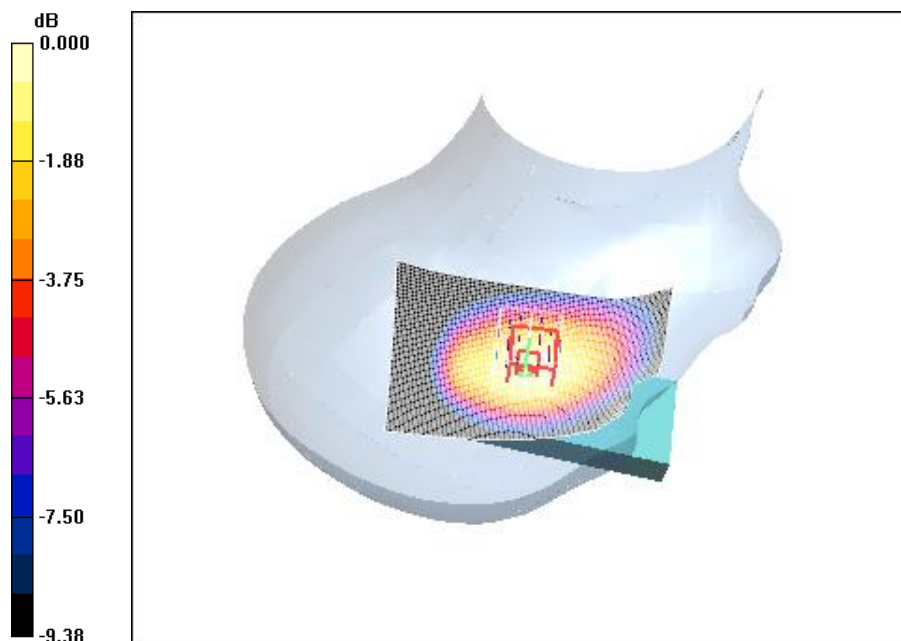

0 dB = 0.522mW/g

SHGSM

16.5.8 GSM850-RightHandSide-Cheek-Low

Date/Time: 2010-5-14 12:34:32

Test Laboratory: SGS-GSM

GSM850-RightHandSide-Touch-Low

DUT: KL006; Type: Head&Body; Serial: 35519200110001178

Communication System: GSM850-GSM Mode; Frequency: 824.2 MHz; Duty Cycle: 1:8.3

Medium: HSL835_Head Medium parameters used: f = 824.2 MHz; $\sigma = 0.884$ mho/m; $\epsilon_r = 42.6$; $\rho = 1000$ kg/m³

Phantom section: Right Section

DASY4 Configuration:

- Probe: ES3DV3 - SN3088; ConvF(5.84, 5.84, 5.84); Calibrated: 2009-11-19
- Sensor-Surface: 4mm (Mechanical Surface Detection)
- Electronics: DAE3 Sn569; Calibrated: 2009-11-18
- Phantom: SAM 12; Type: SAM V4.0; Serial: TP-1283
- Measurement SW: DASY4, V4.7 Build 80; Postprocessing SW: SEMCAD, V1.8 Build 186

Cheek position - Low/Area Scan (61x91x1): **Measurement grid: dx=15mm, dy=15mm**

Maximum value of SAR (interpolated) = 0.905 mW/g

Cheek position - Low/Zoom Scan (7x7x7) (7x7x7)/Cube 0: **Measurement grid: dx=5mm, dy=5mm, dz=5mm**

Reference Value = 15.4 V/m; Power Drift = 0.040 dB

Peak SAR (extrapolated) = 1.11 W/kg

SAR(1 g) = 0.854 mW/g; SAR(10 g) = 0.618 mW/g

Maximum value of SAR (measured) = 0.907 mW/g

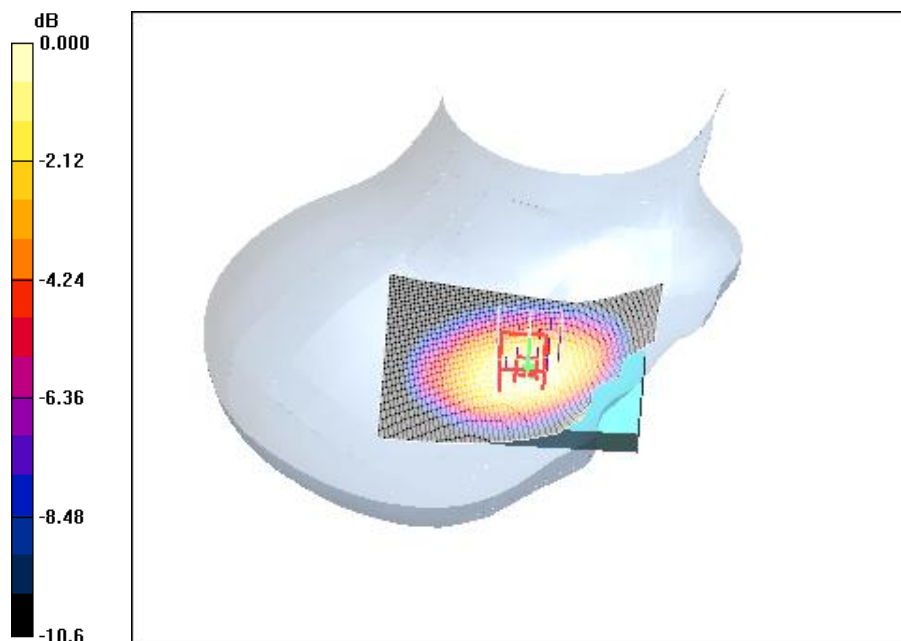

0 dB = 0.907mW/g

SHGSM

16.5.9 GSM850-RightHandSide-Cheek-High

Date/Time: 2010-5-14 12:58:25

Test Laboratory: SGS-GSM

GSM850-RightHandSide-Touch-High

DUT: KL006; Type: Head&Body; Serial: 35519200110001178

Communication System: GSM850-GSM Mode; Frequency: 848.8 MHz;Duty Cycle: 1:8.3

Medium: HSL835_Head Medium parameters used: f = 848.8 MHz; $\sigma = 0.906$ mho/m; $\epsilon_r = 42.3$; $\rho = 1000$ kg/m³

Phantom section: Right Section

DASY4 Configuration:

- Probe: ES3DV3 - SN3088; ConvF(5.84, 5.84, 5.84); Calibrated: 2009-11-19
- Sensor-Surface: 4mm (Mechanical Surface Detection)
- Electronics: DAE3 Sn569; Calibrated: 2009-11-18
- Phantom: SAM 12; Type: SAM V4.0; Serial: TP-1283
- Measurement SW: DASY4, V4.7 Build 80; Postprocessing SW: SEMCAD, V1.8 Build 186

Cheek position - High/Area Scan (61x91x1): **Measurement grid: dx=15mm, dy=15mm**

Maximum value of SAR (interpolated) = 0.890 mW/g

Cheek position - High/Zoom Scan (7x7x7) (7x7x7)/Cube 0: **Measurement grid: dx=5mm, dy=5mm, dz=5mm**

Reference Value = 15.0 V/m; Power Drift = -0.047 dB

Peak SAR (extrapolated) = 1.11 W/kg

SAR(1 g) = 0.840 mW/g; SAR(10 g) = 0.601 mW/g

Maximum value of SAR (measured) = 0.893 mW/g

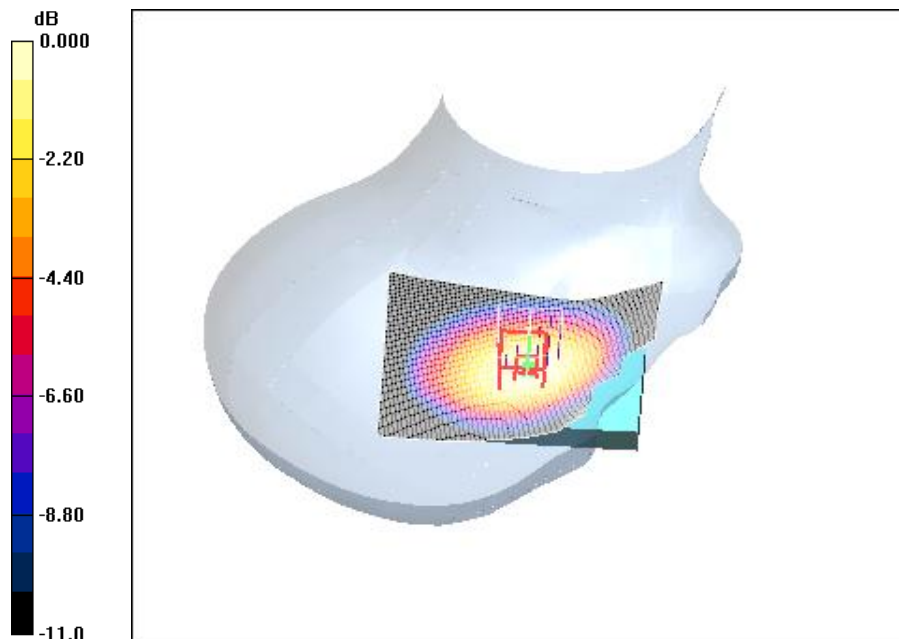

0 dB = 0.893mW/g

SHGSM

16.5.10 GSM850-RightHandSide-Worstcase-With Memory

Date/Time: 2010-5-14 13:24:29

Test Laboratory: SGS-GSM

GSM850-RightHandSide-Touch-Mid With Memory

DUT: KL006; Type: Head&Body; Serial: 35519200110001178

Communication System: GSM850-GSM Mode; Frequency: 836.6 MHz; Duty Cycle: 1:8.3

Medium: HSL835Head Medium parameters used: $f = 836.6\text{MHz}$; $\sigma = 0.895\text{ mho/m}$; $\epsilon_r = 42.5$; $\rho = 1000\text{ kg/m}^3$

Phantom section: Right Section

DASY4 Configuration:

- Probe: ES3DV3 - SN3088; ConvF(5.84, 5.84, 5.84); Calibrated: 2009-11-19
- Sensor-Surface: 4mm (Mechanical Surface Detection)
- Electronics: DAE3 Sn569; Calibrated: 2009-11-18
- Phantom: SAM 12; Type: SAM V4.0; Serial: TP-1283
- Measurement SW: DASY4, V4.7 Build 80; Postprocessing SW: SEMCAD, V1.8 Build 186

Cheek position - Mid With Memory/Area Scan (61x91x1): **Measurement grid: $dx=15\text{mm}$, $dy=15\text{mm}$**

Maximum value of SAR (interpolated) = 0.970 mW/g

Cheek position - Mid With Memory/Zoom Scan (7x7x7) (7x7x7)/Cube 0: **Measurement grid: $dx=5\text{mm}$, $dy=5\text{mm}$, $dz=5\text{mm}$**

Reference Value = 15.9 V/m; Power Drift = -0.057 dB

Peak SAR (extrapolated) = 1.19 W/kg

SAR(1 g) = 0.913 mW/g; SAR(10 g) = 0.657 mW/g

Maximum value of SAR (measured) = 0.973 mW/g

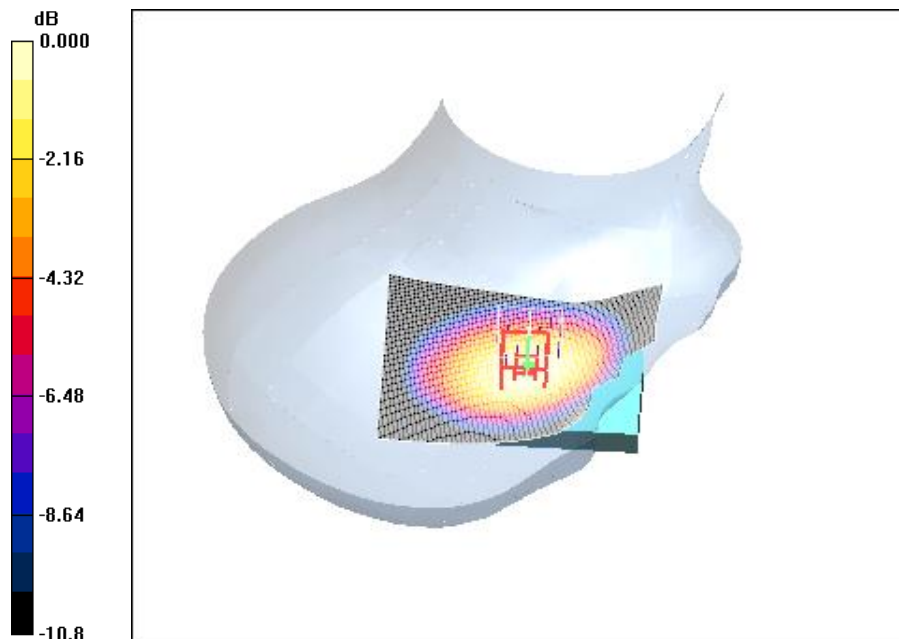

0 dB = 0.973mW/g

SHGSM

16.5.11 GSM850-BodyWorn-GPRS-1Slot-Front-Middle

Date/Time: 2010-5-17 14:06:33

Test Laboratory: SGS-GSM

GSM850-Body-Worn-Front-GPRS-Mid-1TS

DUT: KL006; Type: Head&Body; Serial: 35519200110001178

Communication System: GSM850-GPRS; Frequency: 836.6 MHz; Duty Cycle: 1:8.3

Medium: HSL835 Body Medium parameters used: $f = 836.6 \text{ MHz}$; $\sigma = 0.96 \text{ mho/m}$; $\epsilon_r = 55.2$; $\rho = 1000 \text{ kg/m}^3$

Phantom section: Flat Section

DASY4 Configuration:

- Probe: ES3DV3 - SN3088; ConvF(5.68, 5.68, 5.68); Calibrated: 2009-11-19
- Sensor-Surface: 4mm (Mechanical Surface Detection)
- Electronics: DAE3 Sn569; Calibrated: 2009-11-18
- Phantom: SAM 12; Type: SAM V4.0; Serial: TP-1283
- Measurement SW: DASY4, V4.7 Build 80; Postprocessing SW: SEMCAD, V1.8 Build 186

Body Worn - Middle-Front/Area Scan (81x101x1): **Measurement grid: dx=15mm, dy=15mm**

Maximum value of SAR (interpolated) = 0.563 mW/g

Body Worn - Middle-Front/Zoom Scan (7x7x7)/Cube 0: **Measurement grid: dx=5mm, dy=5mm, dz=5mm**

Reference Value = 14.6 V/m; Power Drift = -0.101 dB

Peak SAR (extrapolated) = 0.691 W/kg

SAR(1 g) = 0.527 mW/g; SAR(10 g) = 0.384 mW/g

Maximum value of SAR (measured) = 0.563 mW/g

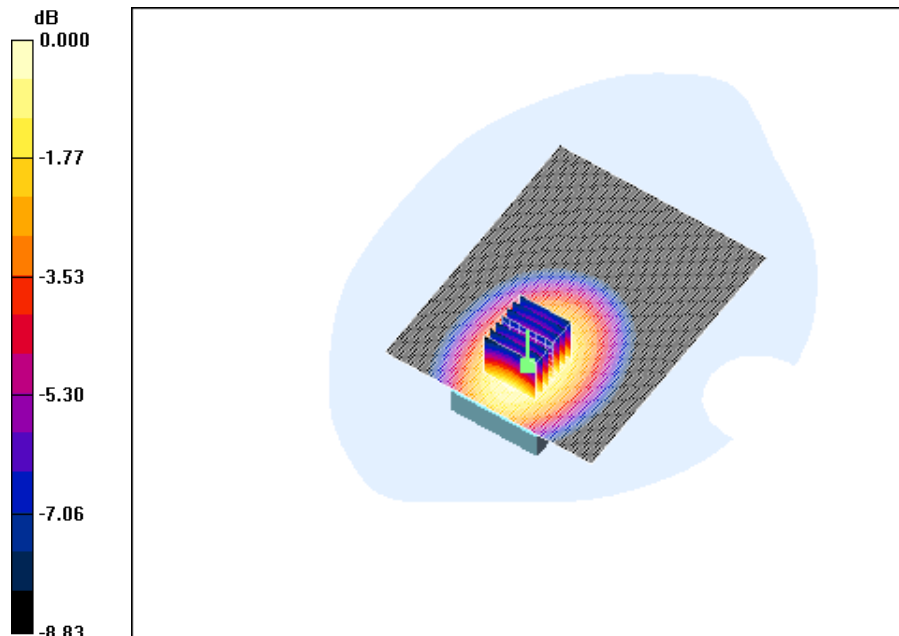

0 dB = 0.563mW/g

16.5.12 GSM850-BodyWorn-GPRS-1Slot-Rear-Middle

Date/Time: 2010-5-18 8:53:28

Test Laboratory: SGS-GSM

GSM850-Body-Worn-Rear-GPRS-Mid-1TS

DUT: KL006; Type: Head&Body; Serial: 35519200110001178

Communication System: GSM850-GPRS; Frequency: 836.6 MHz; Duty Cycle: 1:8.3

Medium: HSL835 Body Medium parameters used: $f = 836.6 \text{ MHz}$; $\sigma = 0.96 \text{ mho/m}$; $\epsilon_r = 55.2$; $\rho = 1000 \text{ kg/m}^3$

Phantom section: Flat Section

DASY4 Configuration:

- Probe: ES3DV3 - SN3088; ConvF(5.68, 5.68, 5.68); Calibrated: 2009-11-19
- Sensor-Surface: 4mm (Mechanical Surface Detection)
- Electronics: DAE3 Sn569; Calibrated: 2009-11-18
- Phantom: SAM 12; Type: SAM V4.0; Serial: TP-1283
- Measurement SW: DASY4, V4.7 Build 80; Postprocessing SW: SEMCAD, V1.8 Build 186

Body Worn - Middle-Rear/Area Scan (81x101x1): **Measurement grid: dx=15mm, dy=15mm**

Maximum value of SAR (interpolated) = 0.646 mW/g

Body Worn - Middle-Rear/Zoom Scan (7x7x7)/Cube 0: **Measurement grid: dx=5mm, dy=5mm, dz=5mm**

Reference Value = 15.9 V/m; Power Drift = -0.069 dB

Peak SAR (extrapolated) = 0.795 W/kg

SAR(1 g) = 0.606 mW/g; SAR(10 g) = 0.440 mW/g

Maximum value of SAR (measured) = 0.642 mW/g

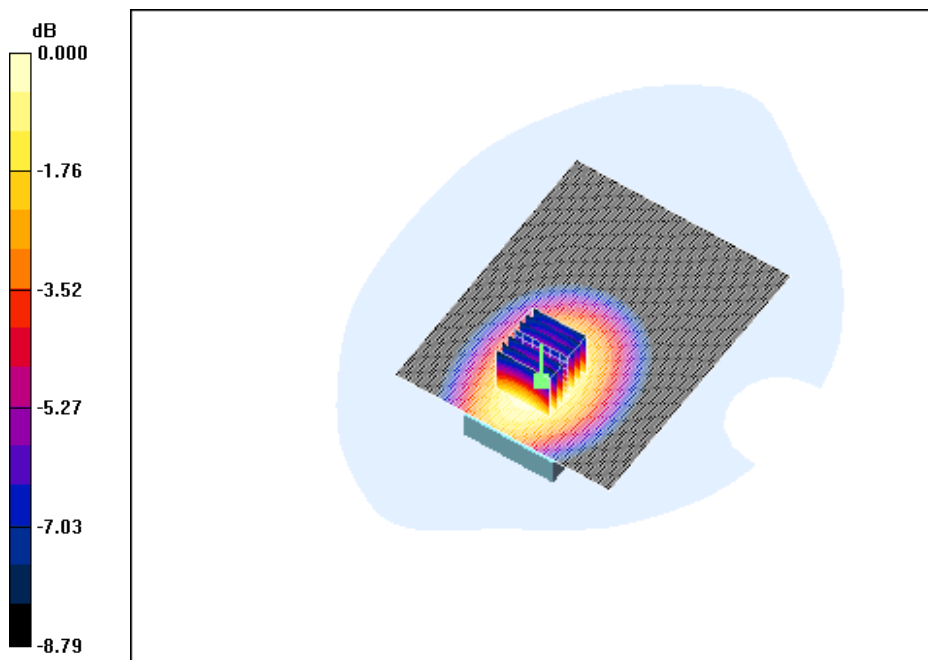

0 dB = 0.642mW/g

16.5.13 GSM850-BodyWorn-GPRS-2Slot-Front-Middle

Date/Time: 2010-5-17 14:34:41

Test Laboratory: SGS-GSM

GSM 850-Body-Worn-GPRS-2TS-Front-Middle

DUT: KL006; Type: Head&Body; Serial: 35519200110001178

Communication System: GSM850-GPRS Mode; Frequency: 836.6 MHz; Duty Cycle: 1:4.15

Medium: HSL835 Body Medium parameters used: $f = 836.6 \text{ MHz}$; $\sigma = 0.96 \text{ mho/m}$; $\epsilon_r = 55.2$; $\rho = 1000 \text{ kg/m}^3$

Phantom section: Flat Section

DASY4 Configuration:

- Probe: ES3DV3 - SN3088; ConvF(5.68, 5.68, 5.68); Calibrated: 2009-11-19
- Sensor-Surface: 4mm (Mechanical Surface Detection)
- Electronics: DAE3 Sn569; Calibrated: 2009-11-18
- Phantom: SAM 12; Type: SAM V4.0; Serial: TP-1283
- Measurement SW: DASY4, V4.7 Build 80; Postprocessing SW: SEMCAD, V1.8 Build 186

Body Worn-Mid -Front/Area Scan (81x91x1): **Measurement grid: $dx=15\text{mm}$, $dy=15\text{mm}$**

Maximum value of SAR (interpolated) = 1.09 mW/g

Body Worn-Mid -Front/Zoom Scan (7x7x7)/Cube 0: **Measurement grid: $dx=5\text{mm}$, $dy=5\text{mm}$, $dz=5\text{mm}$**

Reference Value = 20.2 V/m; Power Drift = -0.049 dB

Peak SAR (extrapolated) = 1.35 W/kg

SAR(1 g) = 1.03 mW/g; SAR(10 g) = 0.746 mW/g

Maximum value of SAR (measured) = 1.09 mW/g

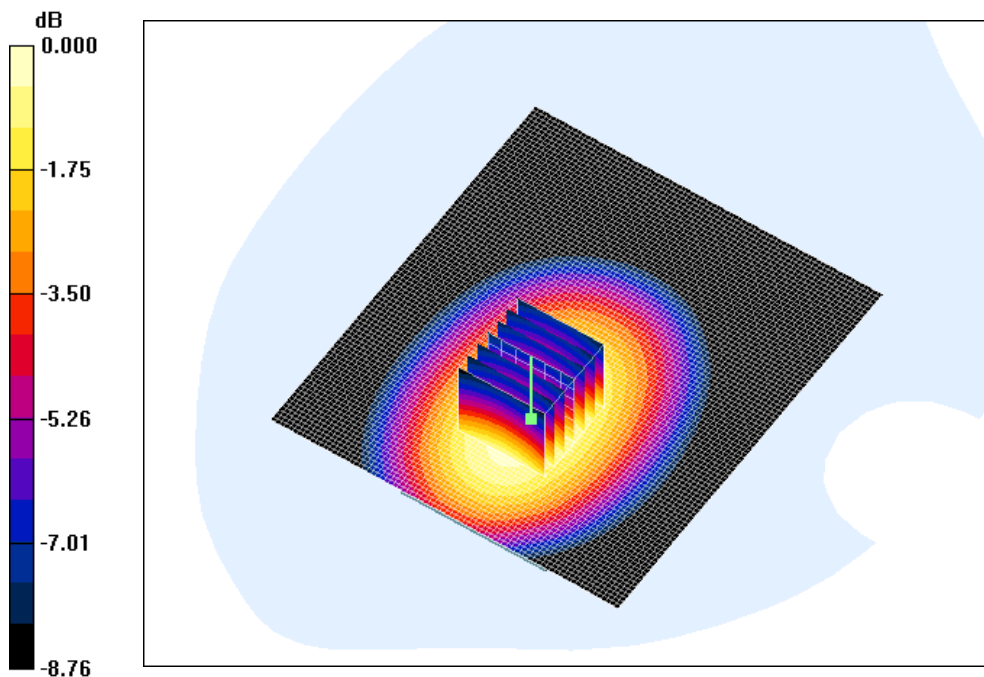

0 dB = 1.09mW/g

SHGSM

16.5.14 GSM850-BodyWorn-GPRS-2Slot-Rear-Middle

Date/Time: 2010-5-17 15:00:26

Test Laboratory: SGS-GSM

GSM 850-Body-Worn-GPRS-2TS-Rear-Middle

DUT: KL006; Type: Head&Body; Serial: 35519200110001178

Communication System: GSM850-GPRS Mode; Frequency: 836.6 MHz; Duty Cycle: 1:4.15

Medium: HSL835 Body Medium parameters used: f = 836.6 MHz; σ = 0.96 mho/m; ϵ_r = 55.2; ρ = 1000 kg/m³

Phantom section: Flat Section

DASY4 Configuration:

- Probe: ES3DV3 - SN3088; ConvF(5.68, 5.68, 5.68); Calibrated: 2009-11-19
- Sensor-Surface: 4mm (Mechanical Surface Detection)
- Electronics: DAE3 Sn569; Calibrated: 2009-11-18
- Phantom: SAM 12; Type: SAM V4.0; Serial: TP-1283
- Measurement SW: DASY4, V4.7 Build 80; Postprocessing SW: SEMCAD, V1.8 Build 186

Body Worn-Mid -Rear/Area Scan (81x91x1): **Measurement grid: dx=15mm, dy=15mm**

Maximum value of SAR (interpolated) = 1.24 mW/g

Body Worn-Mid -Rear/Zoom Scan (7x7x7)/Cube 0: **Measurement grid: dx=5mm, dy=5mm, dz=5mm**

Reference Value = 22.2 V/m; Power Drift = -0.053 dB

Peak SAR (extrapolated) = 1.53 W/kg

SAR(1 g) = 1.16 mW/g; SAR(10 g) = 0.842 mW/g

Maximum value of SAR (measured) = 1.22 mW/g

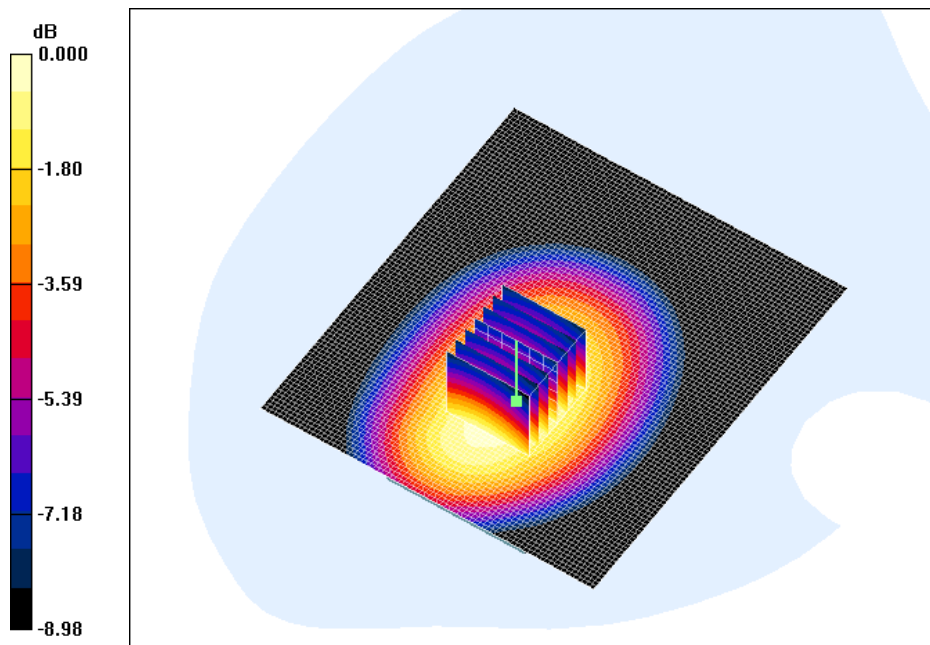

0 dB = 1.22mW/g

SHGSM

16.5.15 GSM850-BodyWorn-GPRS-2Slot-Rear-Low

Date/Time: 2010-5-17 15:47:32

Test Laboratory: SGS-GSM

GSM 850-Body-Worn-GPRS-2TS-Rear-Low

DUT: KL006; Type: Head&Body; Serial: 35519200110001178

Communication System: GSM850-GPRS Mode; Frequency: 824.2 MHz;Duty Cycle: 1:4.15

Medium: HSL835 Body Medium parameters used: f = 824.2 MHz; $\sigma = 0.947$ mho/m; $\epsilon_r = 55.3$; $\rho = 1000$ kg/m³

Phantom section: Flat Section

DASY4 Configuration:

- Probe: ES3DV3 - SN3088; ConvF(5.68, 5.68, 5.68); Calibrated: 2009-11-19
- Sensor-Surface: 4mm (Mechanical Surface Detection)
- Electronics: DAE3 Sn569; Calibrated: 2009-11-18
- Phantom: SAM 12; Type: SAM V4.0; Serial: TP-1283
- Measurement SW: DASY4, V4.7 Build 80; Postprocessing SW: SEMCAD, V1.8 Build 186

Body Worn - Low -Rear/Area Scan (81x101x1): **Measurement grid: dx=15mm, dy=15mm**

Maximum value of SAR (interpolated) = 1.24 mW/g

Body Worn - Low -Rear/Zoom Scan (7x7x7)/Cube 0: **Measurement grid: dx=5mm, dy=5mm, dz=5mm**

Reference Value = 20.9 V/m; Power Drift = -0.070 dB

Peak SAR (extrapolated) = 1.53 W/kg

SAR(1 g) = 1.16 mW/g; SAR(10 g) = 0.847 mW/g

Maximum value of SAR (measured) = 1.24 mW/g

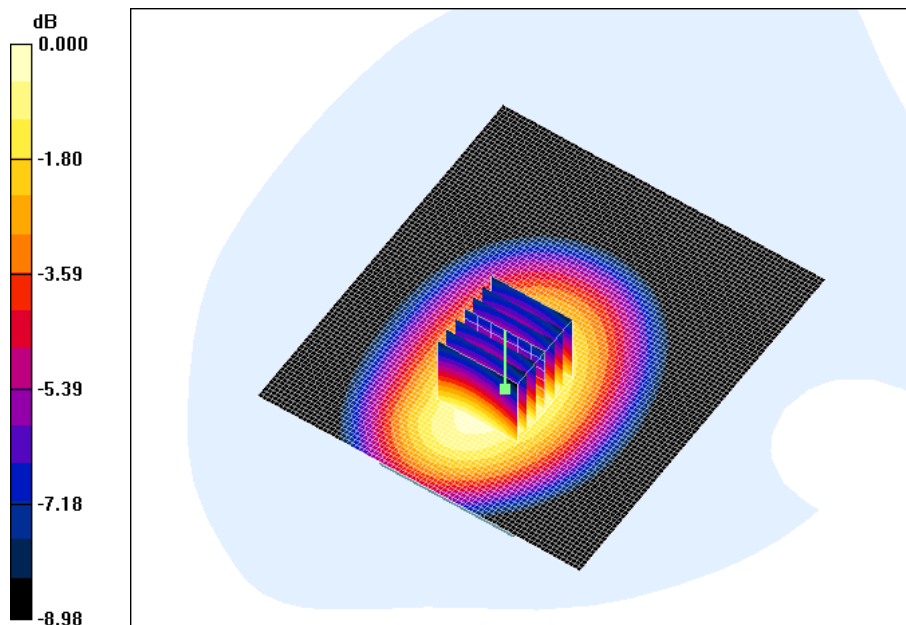

0 dB = 1.24mW/g

SHGSM

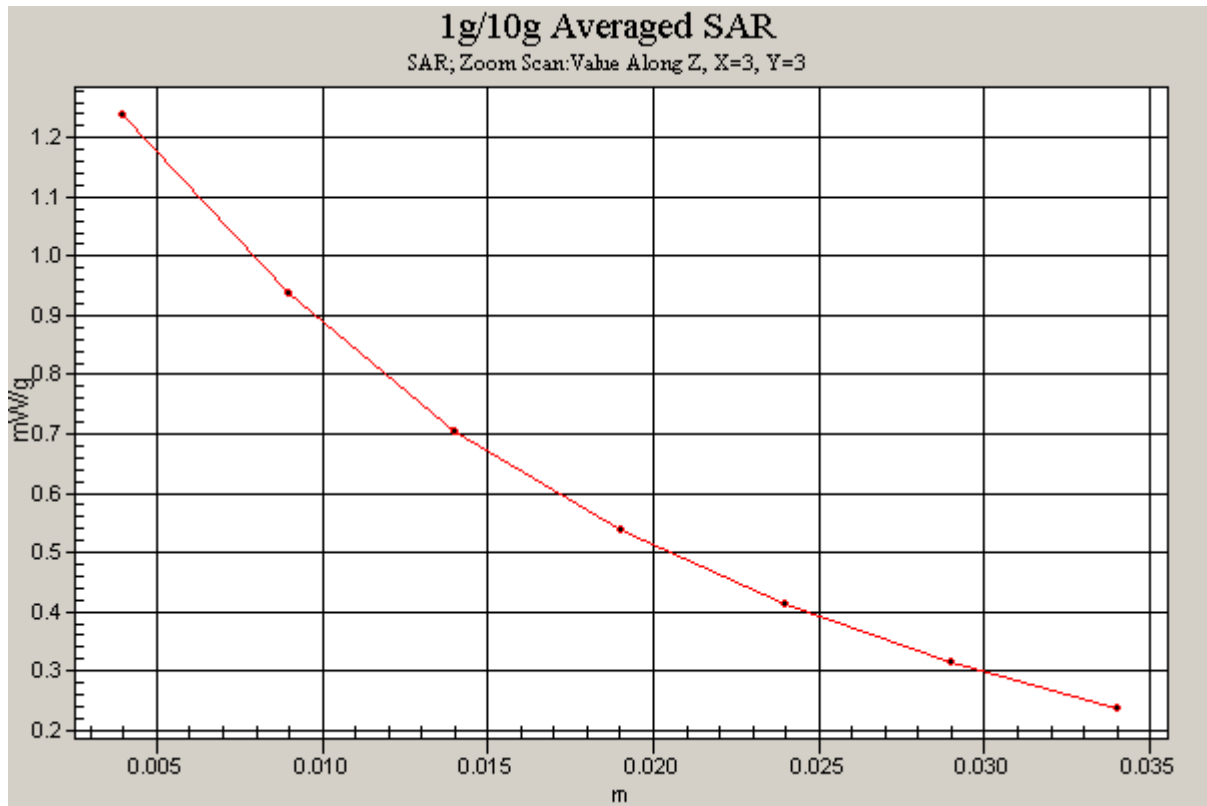

16.5.16 GSM850-BodyWorn-GPRS-2Slot-Rear-High

Date/Time: 2010-5-17 16:14:17

Test Laboratory: SGS-GSM

GSM 850-Body-Worn-GPRS-2TS-Rear-High

DUT: KL006; Type: Head&Body; Serial: 35519200110001178

Communication System: GSM850-GPRS Mode; Frequency: 848.8 MHz; Duty Cycle: 1:4.15

Medium: HSL835 Body Medium parameters used: $f = 848.8$ MHz; $\sigma = 0.973$ mho/m; $\epsilon_r = 55.1$; $\rho = 1000$ kg/m³

Phantom section: Flat Section

DASY4 Configuration:

- Probe: ES3DV3 - SN3088; ConvF(5.68, 5.68, 5.68); Calibrated: 2009-11-19
- Sensor-Surface: 4mm (Mechanical Surface Detection)
- Electronics: DAE3 Sn569; Calibrated: 2009-11-18
- Phantom: SAM 12; Type: SAM V4.0; Serial: TP-1283
- Measurement SW: DASY4, V4.7 Build 80; Postprocessing SW: SEMCAD, V1.8 Build 186

Body Worn-High -Rear/Area Scan (61x81x1): **Measurement grid: dx=15mm, dy=15mm**

Maximum value of SAR (interpolated) = 1.07 mW/g

Body Worn-High -Rear/Zoom Scan (7x7x7)/Cube 0: **Measurement grid: dx=5mm, dy=5mm, dz=5mm**

Reference Value = 19.3 V/m; Power Drift = -0.053 dB

Peak SAR (extrapolated) = 1.34 W/kg

SAR(1 g) = 1 mW/g; SAR(10 g) = 0.724 mW/g

Maximum value of SAR (measured) = 1.06 mW/g

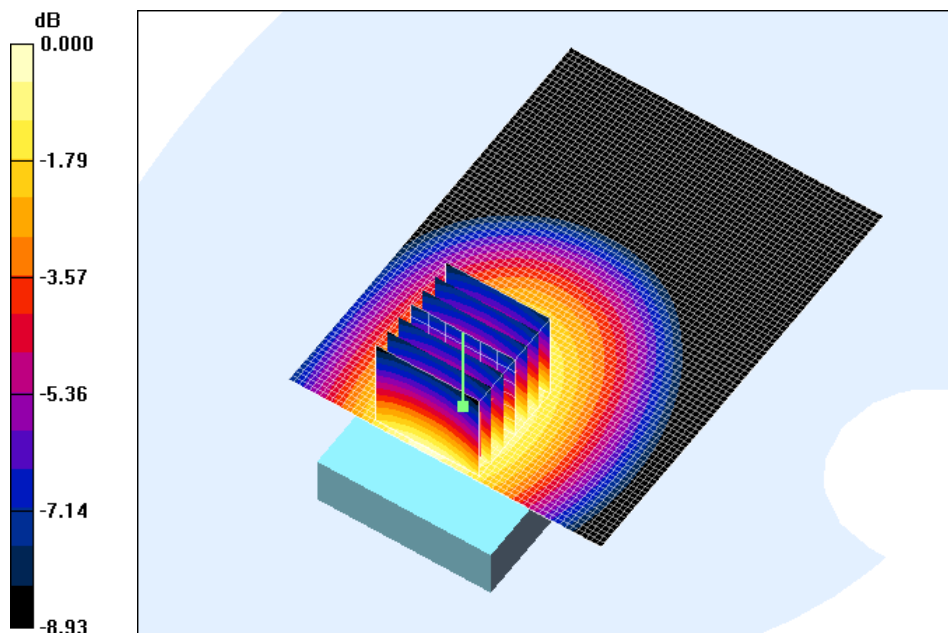

0 dB = 1.06mW/g

16.5.17 GSM850-BodyWorn-GPRS-Worstcase With Headset

Date/Time: 2010-5-17 17:25:16

Test Laboratory: SGS-GSM

GSM 850-Body-Worn-GPRS-2TS-Rear-Low With Headset

DUT: KL006; Type: Head&Body; Serial: 35519200110001178

Communication System: GSM850-GPRS Mode; Frequency: 824.2 MHz;Duty Cycle: 1:4.15

Medium: HSL835 Body Medium parameters used: f = 824.2 MHz; σ = 0.947 mho/m; ϵ_r = 55.3; ρ = 1000 kg/m³

Phantom section: Flat Section

DASY4 Configuration:

- Probe: ES3DV3 - SN3088; ConvF(5.68, 5.68, 5.68); Calibrated: 2009-11-19
- Sensor-Surface: 4mm (Mechanical Surface Detection)
- Electronics: DAE3 Sn569; Calibrated: 2009-11-18
- Phantom: SAM 12; Type: SAM V4.0; Serial: TP-1283
- Measurement SW: DASY4, V4.7 Build 80; Postprocessing SW: SEMCAD, V1.8 Build 186

Body Worn-Low -rear with Headset/Area Scan (61x81x1): **Measurement grid: dx=15mm, dy=15mm**

Maximum value of SAR (interpolated) = 1.23 mW/g

Body Worn-Low -rear with Headset/Zoom Scan (7x7x7)/Cube 0: **Measurement grid: dx=5mm, dy=5mm, dz=5mm**

Reference Value = 20.8 V/m; Power Drift = -0.023 dB

Peak SAR (extrapolated) = 1.55 W/kg

SAR(1 g) = 1.16 mW/g; SAR(10 g) = 0.843 mW/g

Maximum value of SAR (measured) = 1.24 mW/g

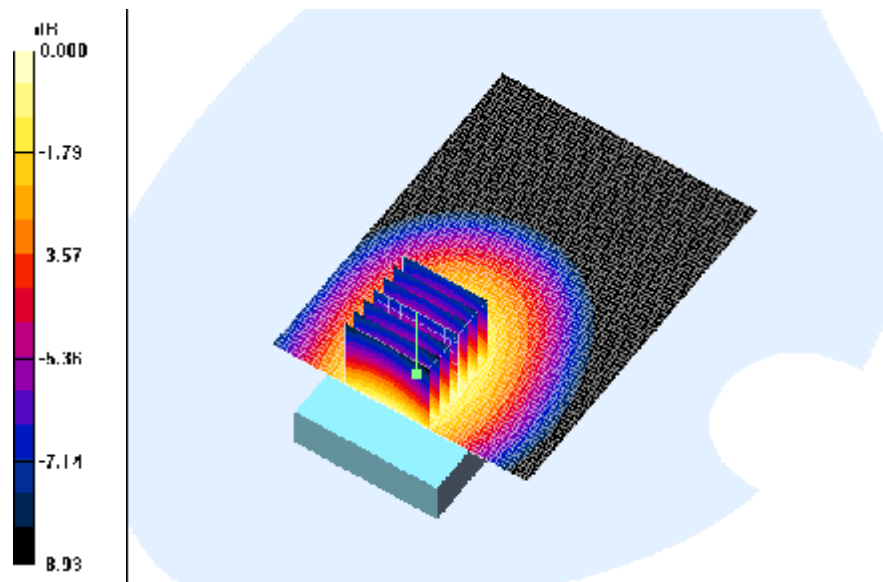

0 dB = 1.24mW/g

SHGSM

16.5.20 GSM850-BodyWorn-GPRS-Worstcase With Memory

Date/Time: 2010-5-17 16:38:43

Test Laboratory: SGS-GSM

GSM 850-Body-Worn-GPRS-2TS-Rear-Low With Memory

DUT: KL006; Type: Head&Body; Serial: 35519200110001178

Communication System: GSM850-GPRS Mode; Frequency: 824.2 MHz; Duty Cycle: 1:4.15

Medium: HSL835 Body Medium parameters used: $f = 824.2 \text{ MHz}$; $\sigma = 0.947 \text{ mho/m}$; $\epsilon_r = 55.3$; $\rho = 1000 \text{ kg/m}^3$

Phantom section: Flat Section

DASY4 Configuration:

- Probe: ES3DV3 - SN3088; ConvF(5.68, 5.68, 5.68); Calibrated: 2009-11-19
- Sensor-Surface: 4mm (Mechanical Surface Detection)
- Electronics: DAE3 Sn569; Calibrated: 2009-11-18
- Phantom: SAM 12; Type: SAM V4.0; Serial: TP-1283
- Measurement SW: DASY4, V4.7 Build 80; Postprocessing SW: SEMCAD, V1.8 Build 186

Body Worn-Low rear with Memory/Area Scan (61x91x1): **Measurement grid: dx=15mm, dy=15mm**

Maximum value of SAR (interpolated) = 1.24 mW/g

Body Worn-Low rear with Memory/Zoom Scan (7x7x7)/Cube 0: **Measurement grid: dx=5mm, dy=5mm, dz=5mm**

Reference Value = 20.8 V/m; Power Drift = -0.025 dB

Peak SAR (extrapolated) = 1.51 W/kg

SAR(1 g) = 1.16 mW/g; SAR(10 g) = 0.845 mW/g

Maximum value of SAR (measured) = 1.23 mW/g

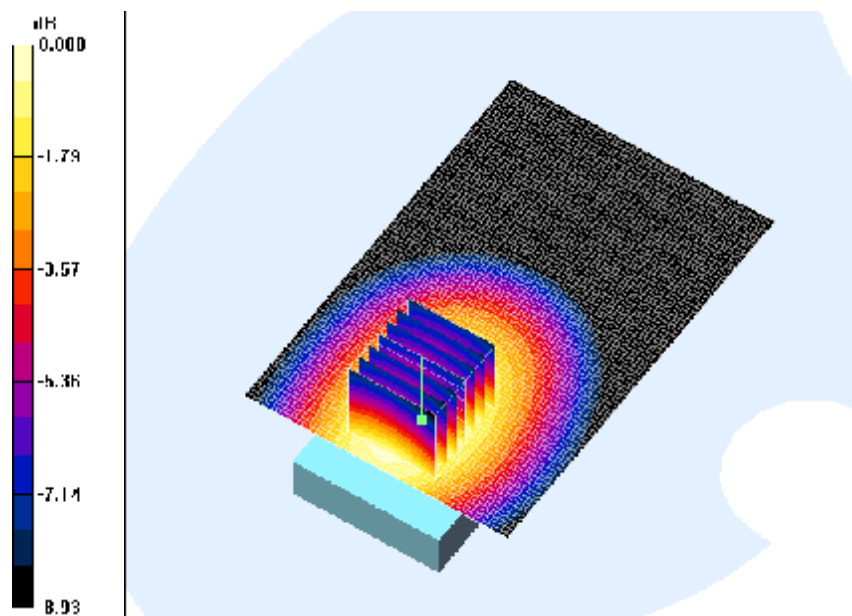

0 dB = 1.23mW/g

SHGSM

16.5.18 PCS1900-LeftHandSide-Cheek-Middle

Date/Time: 2010-5-20 11:50:37

Test Laboratory: SGS-GSM

PCS1900-LeftHandSide-Touch-Mid

DUT: KL006; Type: Head&Body; Serial: 35519200110001178

Communication System: PCS1900-GSM Mode; Frequency: 1880 MHz;Duty Cycle: 1:8.3

Medium: HSL1900_Head Medium parameters used: f = 1880 MHz; $\sigma = 1.4 \text{ mho/m}$; $\epsilon_r = 39$; $\rho = 1000 \text{ kg/m}^3$

Phantom section: Left Section

DASY4 Configuration:

- Probe: ES3DV3 - SN3088; ConvF(4.97, 4.97, 4.97); Calibrated: 2009-11-19
- Sensor-Surface: 4mm (Mechanical Surface Detection)
- Electronics: DAE3 Sn569; Calibrated: 2009-11-18
- Phantom: SAM 12; Type: SAM V4.0; Serial: TP-1283
- Measurement SW: DASY4, V4.7 Build 80; Postprocessing SW: SEMCAD, V1.8 Build 186

Cheek position - Mid/Area Scan (61x121x1): **Measurement grid: dx=15mm, dy=15mm**

Maximum value of SAR (interpolated) = 1.18 mW/g

Cheek position - Mid/Zoom Scan (7x7x7) (7x7x7)/Cube 0: **Measurement grid: dx=5mm, dy=5mm, dz=5mm**

Reference Value = 10.6 V/m; Power Drift = -0.061 dB

Peak SAR (extrapolated) = 1.69 W/kg

SAR(1 g) = 0.998 mW/g; SAR(10 g) = 0.568 mW/g

Maximum value of SAR (measured) = 1.10 mW/g

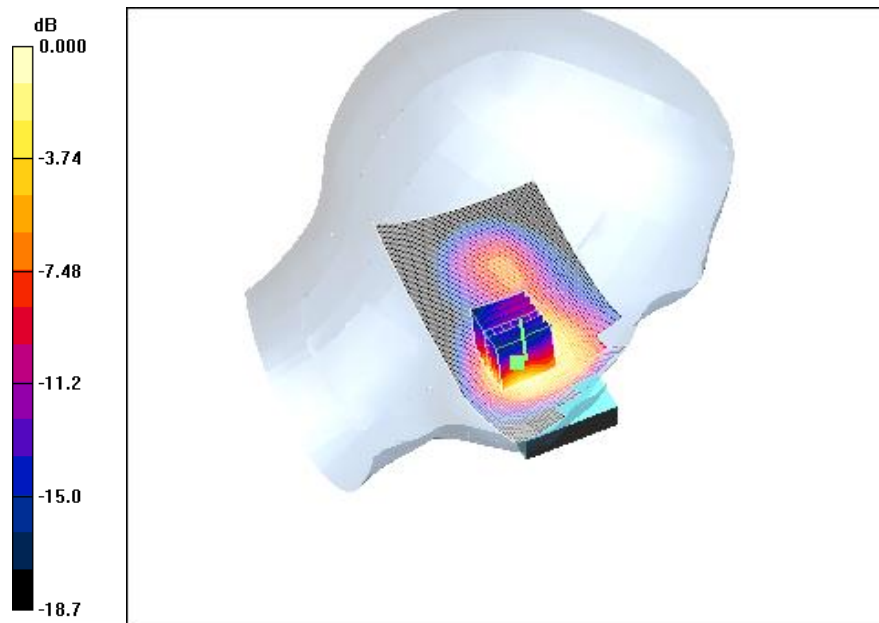

0 dB = 1.10mW/g

SHGSM

16.5.19 PCS1900-LeftHandSide-Tilt-Middle

Date/Time: 2010-5-20 11:24:30

Test Laboratory: SGS-GSM

PCS1900-LeftHandSide-Tilt-Mid

DUT: KL006; Type: Head&Body; Serial: 35519200110001178

Communication System: PCS1900-GSM Mode; Frequency: 1880 MHz;Duty Cycle: 1:8.3

Medium: HSL1900_Head Medium parameters used: f = 1880 MHz; $\sigma = 1.4$ mho/m; $\epsilon_r = 39$; $\rho = 1000$ kg/m³

Phantom section: Left Section

DASY4 Configuration:

- Probe: ES3DV3 - SN3088; ConvF(4.97, 4.97, 4.97); Calibrated: 2009-11-19
- Sensor-Surface: 4mm (Mechanical Surface Detection)
- Electronics: DAE3 Sn569; Calibrated: 2009-11-18
- Phantom: SAM 12; Type: SAM V4.0; Serial: TP-1283
- Measurement SW: DASY4, V4.7 Build 80; Postprocessing SW: SEMCAD, V1.8 Build 186

Tilt position - Mid/Area Scan (61x121x1): **Measurement grid: dx=15mm, dy=15mm**

Maximum value of SAR (interpolated) = 0.335 mW/g

Tilt position - Mid/Zoom Scan (7x7x7) (7x7x7)/Cube 0: **Measurement grid: dx=5mm, dy=5mm, dz=5mm**

Reference Value = 13.7 V/m; Power Drift = -0.171 dB

Peak SAR (extrapolated) = 0.442 W/kg

SAR(1 g) = 0.277 mW/g; SAR(10 g) = 0.159 mW/g

Maximum value of SAR (measured) = 0.303 mW/g

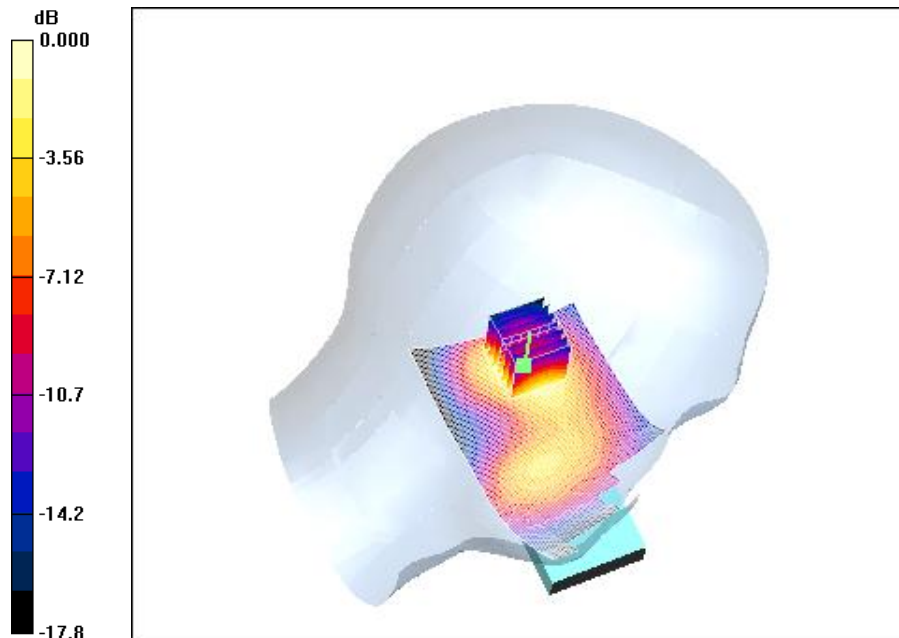

0 dB = 0.303mW/g

16.5.20 PCS1900-LeftHandSide-Cheek-Low

Date/Time: 2010-5-20 12:18:32

Test Laboratory: SGS-GSM

PCS1900-LeftHandSide-Touch-Low

DUT: KL006; Type: Head&Body; Serial: 35519200110001178

Communication System: PCS1900-GSM Mode; Frequency: 1850.2 MHz; Duty Cycle: 1:8.3

Medium: HSL1900_Head Medium parameters used: $f = 1850.2$ MHz; $\sigma = 1.37$ mho/m; $\epsilon_r = 39.1$; $\rho = 1000$ kg/m³

Phantom section: Left Section

DASY4 Configuration:

- Probe: ES3DV3 - SN3088; ConvF(4.97, 4.97, 4.97); Calibrated: 2009-11-19
- Sensor-Surface: 4mm (Mechanical Surface Detection)
- Electronics: DAE3 Sn569; Calibrated: 2009-11-18
- Phantom: SAM 12; Type: SAM V4.0; Serial: TP-1283
- Measurement SW: DASY4, V4.7 Build 80; Postprocessing SW: SEMCAD, V1.8 Build 186

Cheek position - Low/Area Scan (61x121x1): **Measurement grid: dx=15mm, dy=15mm**

Maximum value of SAR (interpolated) = 1.26 mW/g

Cheek position - Low/Zoom Scan (7x7x7) (7x7x7)/Cube 0: **Measurement grid: dx=5mm, dy=5mm, dz=5mm**

Reference Value = 11.1 V/m; Power Drift = -0.035 dB

Peak SAR (extrapolated) = 1.82 W/kg

SAR(1 g) = 1.07 mW/g; SAR(10 g) = 0.601 mW/g

Maximum value of SAR (measured) = 1.19 mW/g

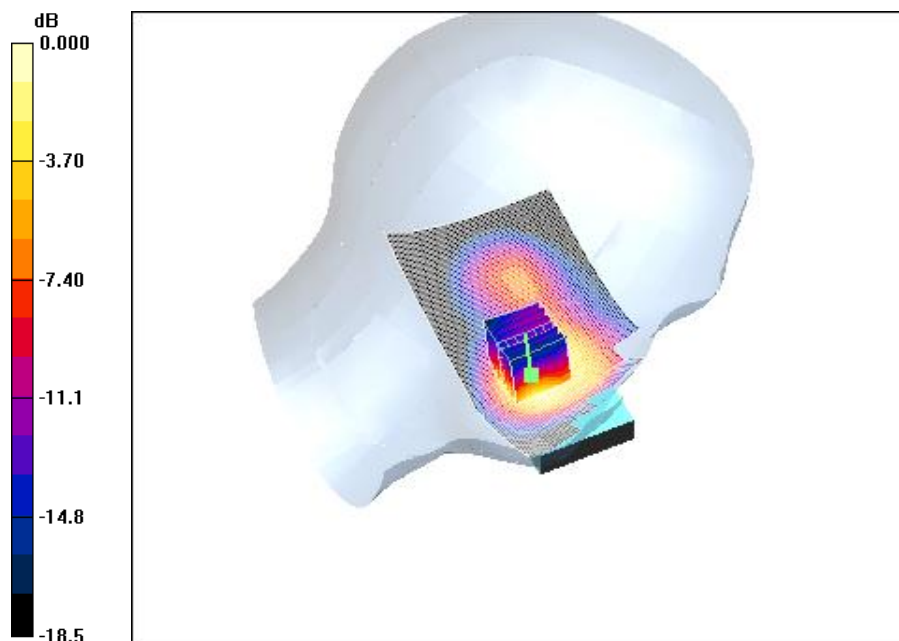

0 dB = 1.19mW/g

SHGSM

16.5.21 PCS1900-LeftHandSide-Cheek-High

Date/Time: 2010-5-20 12:41:48

Test Laboratory: SGS-GSM

PCS1900-LeftHandSide-Touch-High

DUT: KL006; Type: Head&Body; Serial: 35519200110001178

Communication System: PCS1900-GSM Mode; Frequency: 1909.8 MHz;Duty Cycle: 1:8.3

Medium: HSL1900_Head Medium parameters used: f = 1909.8 MHz; σ = 1.43 mho/m; ϵ_r = 38.9; ρ = 1000 kg/m³

Phantom section: Left Section

DASY4 Configuration:

- Probe: ES3DV3 - SN3088; ConvF(4.97, 4.97, 4.97); Calibrated: 2009-11-19
- Sensor-Surface: 4mm (Mechanical Surface Detection)
- Electronics: DAE3 Sn569; Calibrated: 2009-11-18
- Phantom: SAM 12; Type: SAM V4.0; Serial: TP-1283
- Measurement SW: DASY4, V4.7 Build 80; Postprocessing SW: SEMCAD, V1.8 Build 186

Cheek position -High/Area Scan (61x101x1): **Measurement grid: dx=15mm, dy=15mm**

Maximum value of SAR (interpolated) = 1.02 mW/g

Cheek position -High/Zoom Scan (7x7x7) (7x7x7)/Cube 0: **Measurement grid: dx=5mm, dy=5mm, dz=5mm**

Reference Value = 9.03 V/m; Power Drift = 0.008 dB

Peak SAR (extrapolated) = 1.48 W/kg

SAR(1 g) = 0.866 mW/g; SAR(10 g) = 0.492 mW/g

Maximum value of SAR (measured) = 0.952 mW/g

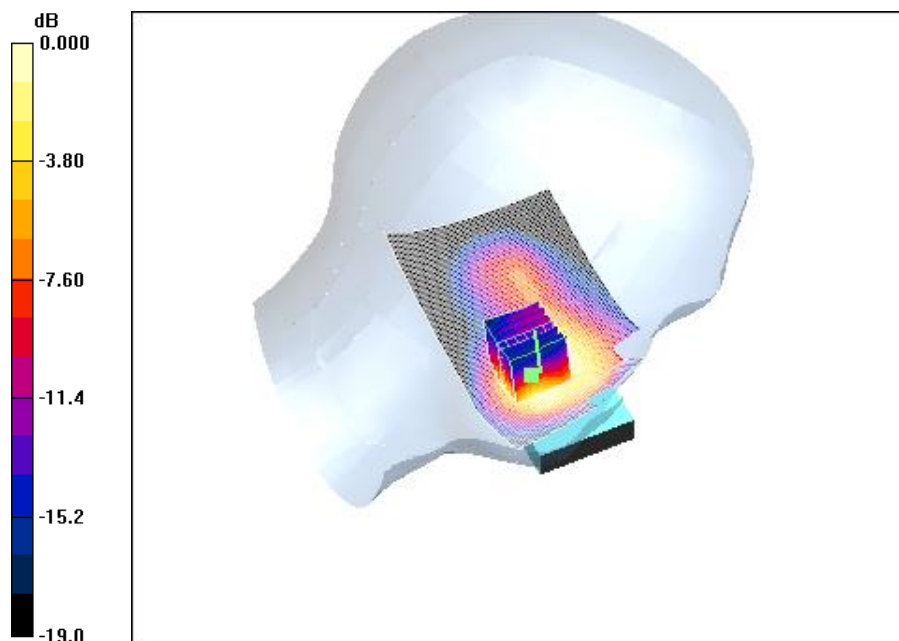

0 dB = 0.952mW/g

SHGSM

16.5.22 PCS1900-LeftHandSide-Worstcase-With Memory

Date/Time: 2010-5-20 13:34:13

Test Laboratory: SGS-GSM

PCS1900-LeftHandSide-Touch-Low With Memory

DUT: KL006; Type: Head&Body; Serial: 35519200110001178

Communication System: PCS1900-GSM Mode; Frequency: 1850.2 MHz;Duty Cycle: 1:8.3

Medium: HSL1900Head Medium parameters used: f = 1850.2 MHz; $\sigma = 1.37$ mho/m; $\epsilon_r = 39.1$; $\rho = 1000$ kg/m³

Phantom section: Left Section

DASY4 Configuration:

- Probe: ES3DV3 - SN3088; ConvF(4.97, 4.97, 4.97); Calibrated: 2009-11-19
- Sensor-Surface: 4mm (Mechanical Surface Detection)
- Electronics: DAE3 Sn569; Calibrated: 2009-11-18
- Phantom: SAM 12; Type: SAM V4.0; Serial: TP-1283
- Measurement SW: DASY4, V4.7 Build 80; Postprocessing SW: SEMCAD, V1.8 Build 186

Cheek position -Low With Memory/Area Scan (61x101x1): **Measurement grid: dx=15mm, dy=15mm**

Maximum value of SAR (interpolated) = 1.26 mW/g

Cheek position -Low With Memory/Zoom Scan (7x7x7) (7x7x7)/Cube 0: **Measurement grid: dx=5mm, dy=5mm, dz=5mm**

Reference Value = 10.9 V/m; Power Drift = -0.050 dB

Peak SAR (extrapolated) = 1.83 W/kg

SAR(1 g) = 1.06 mW/g; SAR(10 g) = 0.594 mW/g

Maximum value of SAR (measured) = 1.18 mW/g

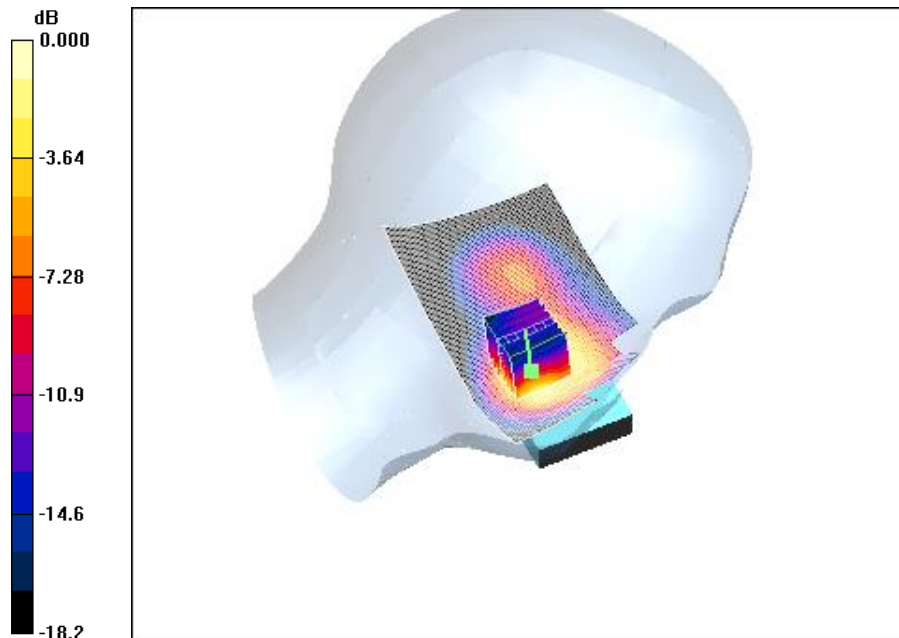

0 dB = 1.18mW/g

16.5.23 PCS1900-RightHandSide-Cheek-Middle

Date/Time: 2010-5-20 14:29:56

Test Laboratory: SGS-GSM

PCS1900-RightHandSide-Touch-Mid

DUT: KL006; Type: Head&Body; Serial: 35519200110001178

Communication System: PCS1900-GSM Mode; Frequency: 1880 MHz;Duty Cycle: 1:8.3

Medium: HSL1900_Head Medium parameters used: f = 1880 MHz; σ = 1.4 mho/m; ϵ_r = 39; ρ = 1000 kg/m³

Phantom section: Right Section

DASY4 Configuration:

- Probe: ES3DV3 - SN3088; ConvF(4.97, 4.97, 4.97); Calibrated: 2009-11-19
- Sensor-Surface: 4mm (Mechanical Surface Detection)
- Electronics: DAE3 Sn569; Calibrated: 2009-11-18
- Phantom: SAM 12; Type: SAM V4.0; Serial: TP-1283
- Measurement SW: DASY4, V4.7 Build 80; Postprocessing SW: SEMCAD, V1.8 Build 186

Cheek position - Middle/Area Scan (61x91x1): **Measurement grid: dx=15mm, dy=15mm**

Maximum value of SAR (interpolated) = 0.784 mW/g

Cheek position - Middle/Zoom Scan (7x7x7)/Cube 0: **Measurement grid: dx=5mm, dy=5mm, dz=5mm**

Reference Value = 10.6 V/m; Power Drift = -0.019 dB

Peak SAR (extrapolated) = 1.08 W/kg

SAR(1 g) = 0.702 mW/g; SAR(10 g) = 0.408 mW/g

Maximum value of SAR (measured) = 0.775 mW/g

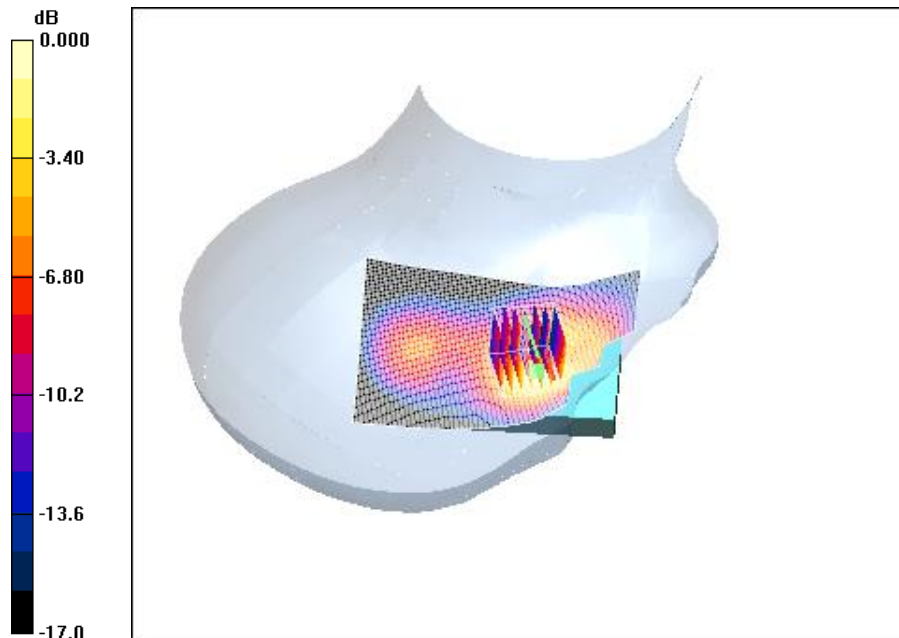

0 dB = 0.775mW/g

16.5.24 PCS1900-RightHandSide-Tilt-Middle

Date/Time: 2010-5-20 14:04:45

Test Laboratory: SGS-GSM

PCS1900-RightHandSide-Tilt-Mid

DUT: KL006; Type: Head&Body; Serial: 35519200110001178

Communication System: PCS1900-GSM Mode; Frequency: 1880 MHz;Duty Cycle: 1:8.3

Medium: HSL1900_Head Medium parameters used: f = 1880 MHz; $\sigma = 1.4$ mho/m; $\epsilon_r = 39$; $\rho = 1000$ kg/m³

Phantom section: Right Section

DASY4 Configuration:

- Probe: ES3DV3 - SN3088; ConvF(4.97, 4.97, 4.97); Calibrated: 2009-11-19
- Sensor-Surface: 4mm (Mechanical Surface Detection)
- Electronics: DAE3 Sn569; Calibrated: 2009-11-18
- Phantom: SAM 12; Type: SAM V4.0; Serial: TP-1283
- Measurement SW: DASY4, V4.7 Build 80; Postprocessing SW: SEMCAD, V1.8 Build 186

Tilt position - Middle/Area Scan (61x101x1): **Measurement grid: dx=15mm, dy=15mm**

Maximum value of SAR (interpolated) = 0.207 mW/g

Tilt position - Middle/Zoom Scan (7x7x7)/Cube 0: **Measurement grid: dx=5mm, dy=5mm, dz=5mm**

Reference Value = 11.6 V/m; Power Drift = 0.009 dB

Peak SAR (extrapolated) = 0.270 W/kg

SAR(1 g) = 0.176 mW/g; SAR(10 g) = 0.104 mW/g

Maximum value of SAR (measured) = 0.190 mW/g

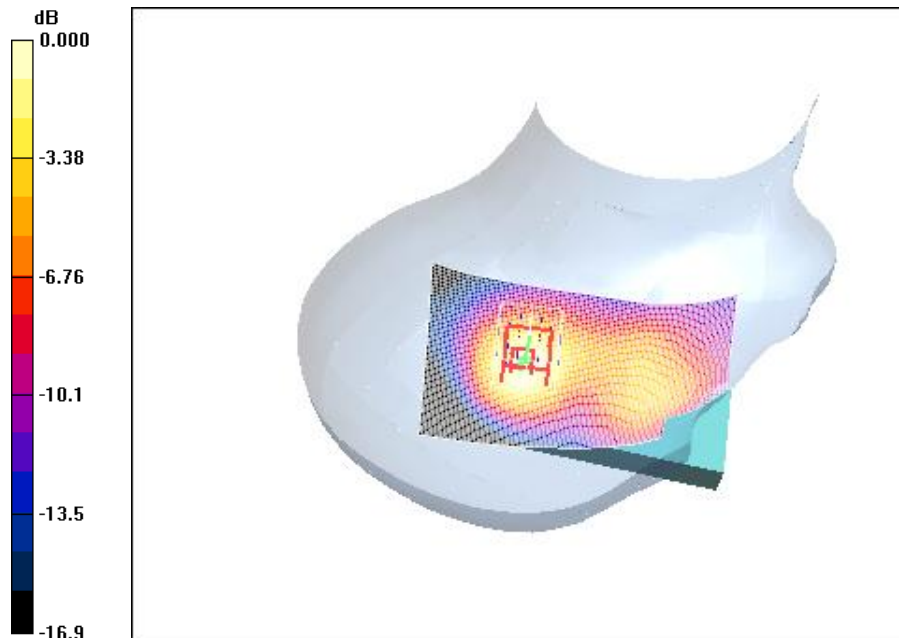

0 dB = 0.190mW/g

16.5.25 PCS1900-RightHandSide-Cheek-Low

Date/Time: 2010-5-20 14:55:01

Test Laboratory: SGS-GSM

PCS1900-RightHandSide-Touch-Low

DUT: KL006; Type: Head&Body; Serial: 35519200110001178

Communication System: PCS1900-GSM Mode; Frequency: 1850.2 MHz;Duty Cycle: 1:8.3

Medium: HSL1900_Head Medium parameters used: f = 1850.2 MHz; σ = 1.37 mho/m; ϵ_r = 39.1; ρ = 1000 kg/m³

Phantom section: Right Section

DASY4 Configuration:

- Probe: ES3DV3 - SN3088; ConvF(4.97, 4.97, 4.97); Calibrated: 2009-11-19
- Sensor-Surface: 4mm (Mechanical Surface Detection)
- Electronics: DAE3 Sn569; Calibrated: 2009-11-18
- Phantom: SAM 12; Type: SAM V4.0; Serial: TP-1283
- Measurement SW: DASY4, V4.7 Build 80; Postprocessing SW: SEMCAD, V1.8 Build 186

Cheek position - Low/Area Scan (61x101x1): **Measurement grid: dx=15mm, dy=15mm**

Maximum value of SAR (interpolated) = 0.843 mW/g

Cheek position - Low/Zoom Scan (7x7x7) (7x7x7)/Cube 0: **Measurement grid: dx=5mm, dy=5mm, dz=5mm**

Reference Value = 11.4 V/m; Power Drift = 0.029 dB

Peak SAR (extrapolated) = 1.13 W/kg

SAR(1 g) = 0.723 mW/g; SAR(10 g) = 0.430 mW/g

Maximum value of SAR (measured) = 0.797 mW/g

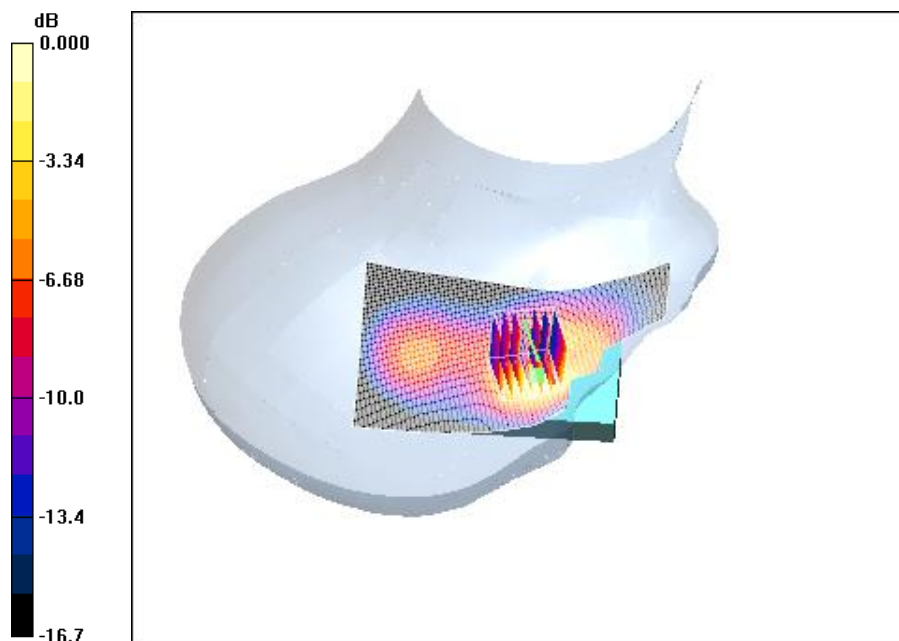

0 dB = 0.797mW/g

SHGSM

16.5.26 PCS1900-RightHandSide-Cheek-High

Date/Time: 2010-5-20 15:20:07

Test Laboratory: SGS-GSM

PCS1900-RightHandSide-Touch-High

DUT: KL006; Type: Head&Body; Serial: 35519200110001178

Communication System: PCS1900-GSM Mode; Frequency: 1909.8 MHz; Duty Cycle: 1:8.3

Medium: HSL1900_Head Medium parameters used: $f = 1909.8 \text{ MHz}$; $\sigma = 1.43 \text{ mho/m}$; $\epsilon_r = 38.9$; $\rho = 1000 \text{ kg/m}^3$

Phantom section: Right Section

DASY4 Configuration:

- Probe: ES3DV3 - SN3088; ConvF(4.97, 4.97, 4.97); Calibrated: 2009-11-19
- Sensor-Surface: 4mm (Mechanical Surface Detection)
- Electronics: DAE3 Sn569; Calibrated: 2009-11-18
- Phantom: SAM 12; Type: SAM V4.0; Serial: TP-1283
- Measurement SW: DASY4, V4.7 Build 80; Postprocessing SW: SEMCAD, V1.8 Build 186

Cheek position - High/Area Scan (61x101x1): **Measurement grid: $dx=15\text{mm}$, $dy=15\text{mm}$**

Maximum value of SAR (interpolated) = 0.709 mW/g

Cheek position - High/Zoom Scan (7x7x7) (7x7x7)/Cube 0: **Measurement grid: $dx=5\text{mm}$, $dy=5\text{mm}$, $dz=5\text{mm}$**

Reference Value = 9.41 V/m; Power Drift = 0.050 dB

Peak SAR (extrapolated) = 1.02 W/kg

SAR(1 g) = 0.665 mW/g; SAR(10 g) = 0.382 mW/g

Maximum value of SAR (measured) = 0.740 mW/g

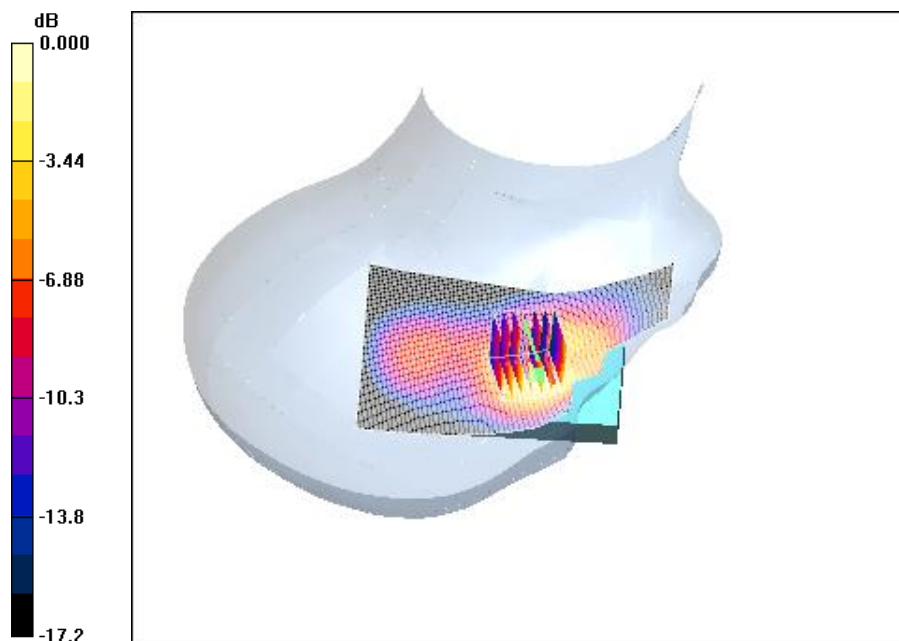

0 dB = 0.740mW/g

SHGSM

16.5.27 PCS1900-RightHandSide-Worstcase-With Memory

Date/Time: 2010-5-20 15:45:29

Test Laboratory: SGS-GSM

PCS1900-RightHandSide-Touch-Low With Memory

DUT: KL006; Type: Head&Body; Serial: 35519200110001178

Communication System: PCS1900-GSM Mode; Frequency: 1850.2 MHz;Duty Cycle: 1:8.3

Medium: HSL1900_Head Medium parameters used: f = 1850.2 MHz; σ = 1.37 mho/m; ϵ_r = 39.1; ρ = 1000 kg/m³

Phantom section: Right Section

DASY4 Configuration:

- Probe: ES3DV3 - SN3088; ConvF(4.97, 4.97, 4.97); Calibrated: 2009-11-19
- Sensor-Surface: 4mm (Mechanical Surface Detection)
- Electronics: DAE3 Sn569; Calibrated: 2009-11-18
- Phantom: SAM 12; Type: SAM V4.0; Serial: TP-1283
- Measurement SW: DASY4, V4.7 Build 80; Postprocessing SW: SEMCAD, V1.8 Build 186

Cheek position - Low With Memory/Area Scan (61x101x1): **Measurement grid: dx=15mm, dy=15mm**

Maximum value of SAR (interpolated) = 0.842 mW/g

Cheek position - Low With Memory/Zoom Scan (7x7x7) (7x7x7)/Cube 0: **Measurement grid: dx=5mm, dy=5mm, dz=5mm**

Reference Value = 11.3 V/m; Power Drift = 0.052 dB

Peak SAR (extrapolated) = 1.13 W/kg

SAR(1 g) = 0.725 mW/g; SAR(10 g) = 0.430 mW/g

Maximum value of SAR (measured) = 0.799 mW/g

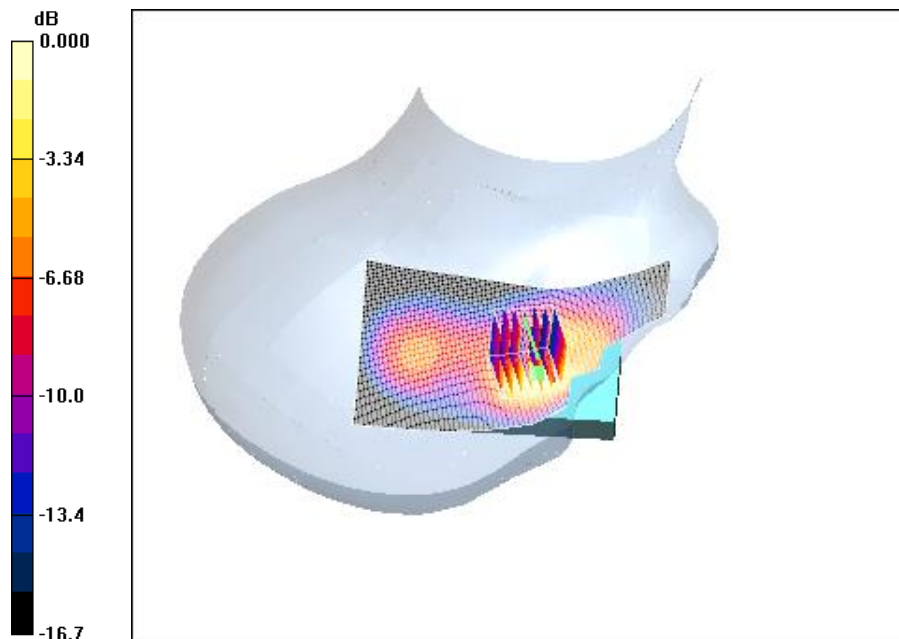

0 dB = 0.799mW/g

SHGSM

16.5.28 PCS1900-BodyWorn-GPRS-1Slot-Rear-Middle

Date/Time: 2010-5-19 17:54:50

Test Laboratory: SGS-GSM

PCS1900-Body-Worn-Rear-GPRS-Mid-1TS

DUT: KL006; Type: Head&Body; Serial: 35519200110001178

Communication System: PCS1900-GPRS Mode; Frequency: 1880 MHz;Duty Cycle: 1:8.3

Medium: HSL 1900 Body Medium parameters used: f = 1880 MHz; σ = 1.51 mho/m; ϵ_r = 52.8; ρ = 1000 kg/m³

Phantom section: Flat Section

DASY4 Configuration:

- Probe: ES3DV3 - SN3088; ConvF(4.58, 4.58, 4.58); Calibrated: 2009-11-19
- Sensor-Surface: 4mm (Mechanical Surface Detection)
- Electronics: DAE3 Sn569; Calibrated: 2009-11-18
- Phantom: SAM 12; Type: SAM V4.0; Serial: TP-1283
- Measurement SW: DASY4, V4.7 Build 80; Postprocessing SW: SEMCAD, V1.8 Build 186

Body Worn - Middle Rear/Area Scan (61x91x1): **Measurement grid: dx=15mm, dy=15mm**

Maximum value of SAR (interpolated) = 0.487 mW/g

Body Worn - Middle Rear/Zoom Scan (7x7x7)/Cube 0: **Measurement grid: dx=5mm, dy=5mm, dz=5mm**

Reference Value = 8.50 V/m; Power Drift = -0.015 dB

Peak SAR (extrapolated) = 0.700 W/kg

SAR(1 g) = 0.451 mW/g; SAR(10 g) = 0.275 mW/g

Maximum value of SAR (measured) = 0.491 mW/g

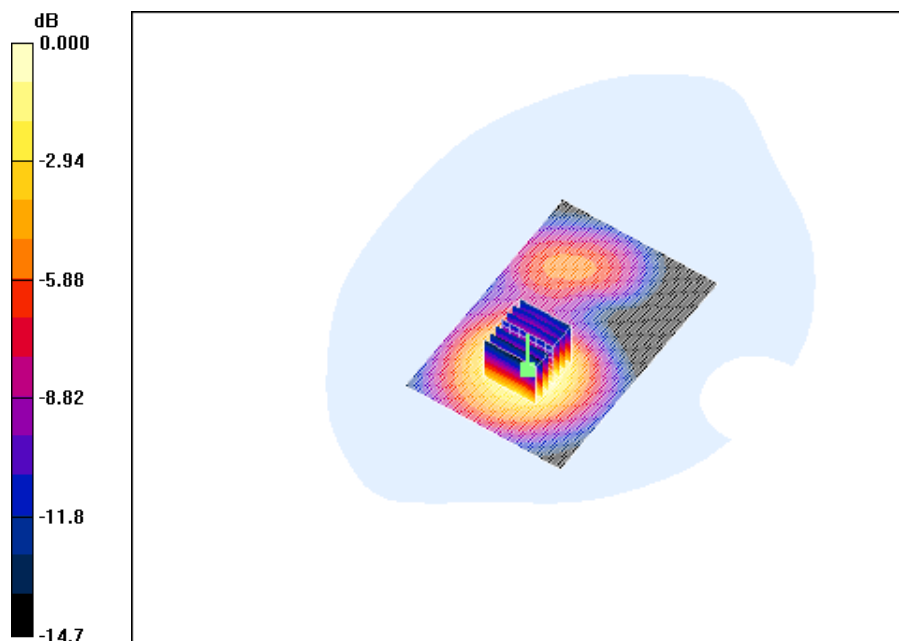

0 dB = 0.491mW/g

SHGSM

16.5.29 PCS1900-BodyWorn-GPRS-2Slot-Rear-Middle

Date/Time: 2010-5-19 20:20:33

Test Laboratory: SGS-GSM

PCS 1900-Body-Worn-GPRS-2TS-Rear-Middle

DUT: KL006; Type: Body&Head; Serial: 3551920011000117

Communication System: PCS1900-GPRS Mode; Frequency: 1880 MHz;Duty Cycle: 1:4.15

Medium: HSL 1900 Body Medium parameters used: $f = 1880$ MHz; $\sigma = 1.5$ mho/m; $\epsilon_r = 53.8$; $\rho = 1000$ kg/m³

Phantom section: Flat Section

DASY4 Configuration:

- Probe: ES3DV3 - SN3088; ConvF(4.58, 4.58, 4.58); Calibrated: 2009-11-19
- Sensor-Surface: 4mm (Mechanical Surface Detection)
- Electronics: DAE3 Sn569; Calibrated: 2009-11-18
- Phantom: SAM 12; Type: SAM V4.0; Serial: TP-1283
- Measurement SW: DASY4, V4.7 Build 80; Postprocessing SW: SEMCAD, V1.8 Build 186

Body Worn - Middle Rear/Area Scan (61x91x1): **Measurement grid: dx=15mm, dy=15mm**

Maximum value of SAR (interpolated) = 0.820 mW/g

Body Worn - Middle Rear/Zoom Scan (7x7x7)/Cube 0: **Measurement grid: dx=5mm, dy=5mm, dz=5mm**

Reference Value = 8.62 V/m; Power Drift = 0.139 dB

Peak SAR (extrapolated) = 1.20 W/kg

SAR(1 g) = 0.764 mW/g; SAR(10 g) = 0.465 mW/g

Maximum value of SAR (measured) = 0.833 mW/g

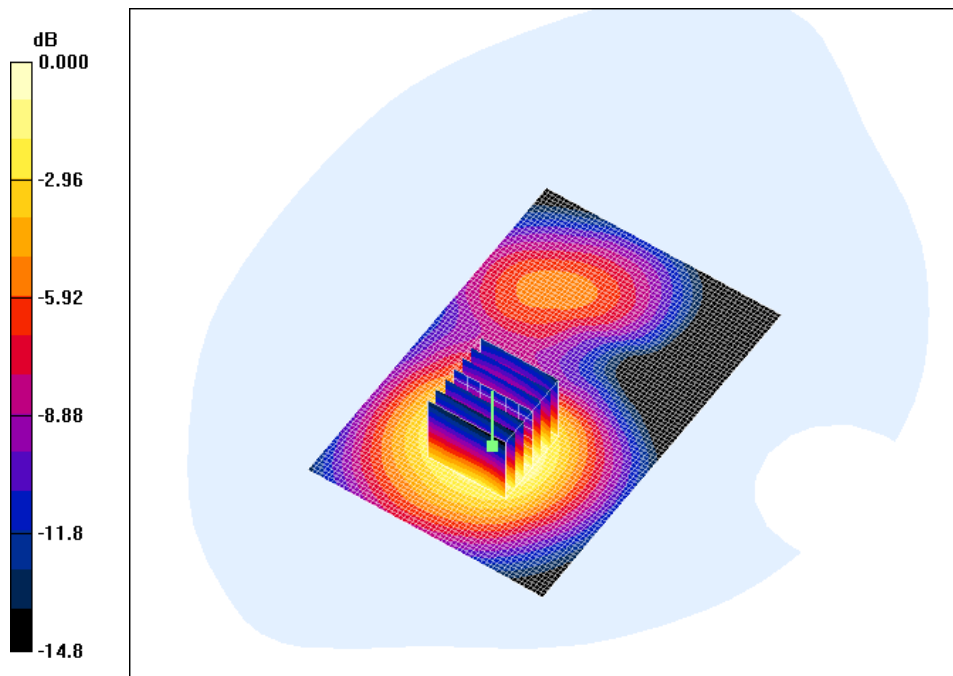

0 dB = 0.833mW/g

SHGSM

16.5.30 PCS1900-BodyWorn-GPRS-2Slot-Front-Middle

Date/Time: 2010-5-19 20:46:24

Test Laboratory: SGS-GSM

PCS 1900-Body-Worn-GPRS-2TS-Front-Middle

DUT: KL006; Type: Body&Head; Serial: 3551920011000117

Communication System: PCS1900-GPRS Mode; Frequency: 1880 MHz;Duty Cycle: 1:4.15

Medium: HSL 1900 Body Medium parameters used: f = 1880 MHz; σ = 1.5 mho/m; ϵ_r = 53.8; ρ = 1000 kg/m³

Phantom section: Flat Section

DASY4 Configuration:

- Probe: ES3DV3 - SN3088; ConvF(4.58, 4.58, 4.58); Calibrated: 2009-11-19
- Sensor-Surface: 4mm (Mechanical Surface Detection)
- Electronics: DAE3 Sn569; Calibrated: 2009-11-18
- Phantom: SAM 12; Type: SAM V4.0; Serial: TP-1283
- Measurement SW: DASY4, V4.7 Build 80; Postprocessing SW: SEMCAD, V1.8 Build 186

Body Worn - Middle Front/Area Scan (61x91x1): **Measurement grid: dx=15mm, dy=15mm**

Maximum value of SAR (interpolated) = 0.501 mW/g

Body Worn - Middle Front/Zoom Scan (7x7x7)/Cube 0: **Measurement grid: dx=5mm, dy=5mm, dz=5mm**

Reference Value = 12.0 V/m; Power Drift = -0.012 dB

Peak SAR (extrapolated) = 0.719 W/kg

SAR(1 g) = 0.459 mW/g; SAR(10 g) = 0.276 mW/g

Maximum value of SAR (measured) = 0.502 mW/g

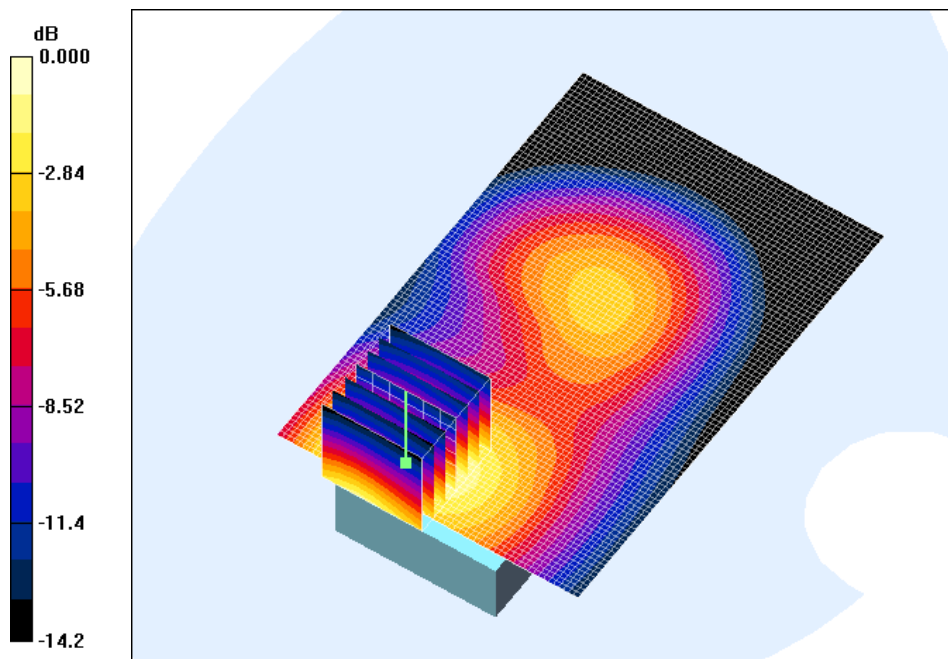

0 dB = 0.502mW/g

SHGSM

16.5.31 PCS1900-BodyWorn-GPRS-2Slot-Rear-Low

Date/Time: 2010-5-19 21:13:14

Test Laboratory: SGS-GSM

PCS 1900-Body-Worn-GPRS-2TS-Rear-Low

DUT: KL006; Type: Body&Head; Serial: 3551920011000117

Communication System: PCS1900-GPRS Mode; Frequency: 1850.2 MHz;Duty Cycle: 1:4.15

Medium: HSL 1900 Body Medium parameters used: $f = 1850.2$ MHz; $\sigma = 1.46$ mho/m; $\epsilon_r = 53.9$; $\rho = 1000$ kg/m³

Phantom section: Flat Section

DASY4 Configuration:

- Probe: ES3DV3 - SN3088; ConvF(4.58, 4.58, 4.58); Calibrated: 2009-11-19
- Sensor-Surface: 4mm (Mechanical Surface Detection)
- Electronics: DAE3 Sn569; Calibrated: 2009-11-18
- Phantom: SAM 12; Type: SAM V4.0; Serial: TP-1283
- Measurement SW: DASY4, V4.7 Build 80; Postprocessing SW: SEMCAD, V1.8 Build 186

Body Worn- Low Rear/Area Scan (61x81x1): **Measurement grid: dx=15mm, dy=15mm**

Maximum value of SAR (interpolated) = 0.935 mW/g

Body Worn- Low Rear/Zoom Scan (7x7x7)/Cube 0: **Measurement grid: dx=5mm, dy=5mm, dz=5mm**

Reference Value = 9.62 V/m; Power Drift = 0.135 dB

Peak SAR (extrapolated) = 1.36 W/kg

SAR(1 g) = 0.864 mW/g; SAR(10 g) = 0.522 mW/g

Maximum value of SAR (measured) = 0.941 mW/g

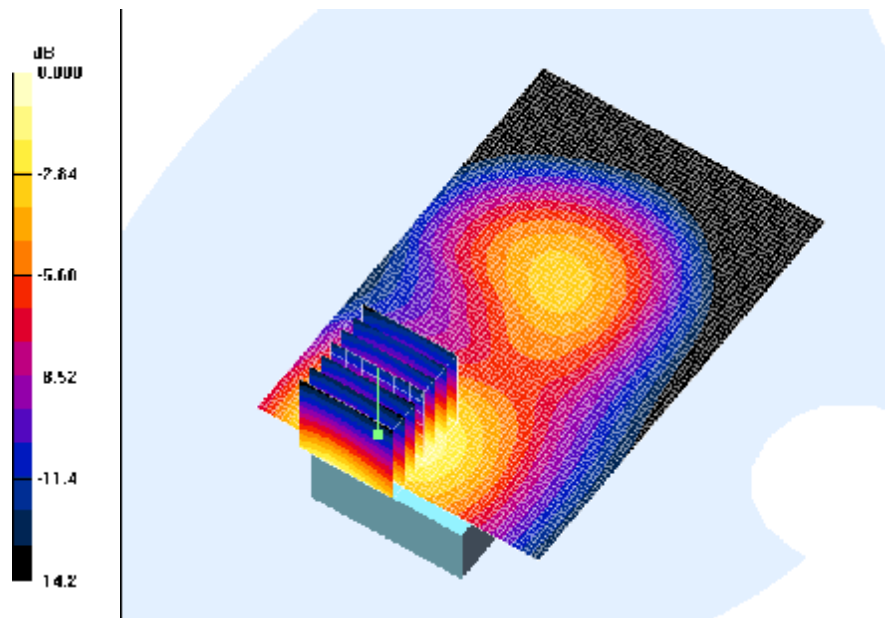

0 dB = 0.941mW/g

SHGSM

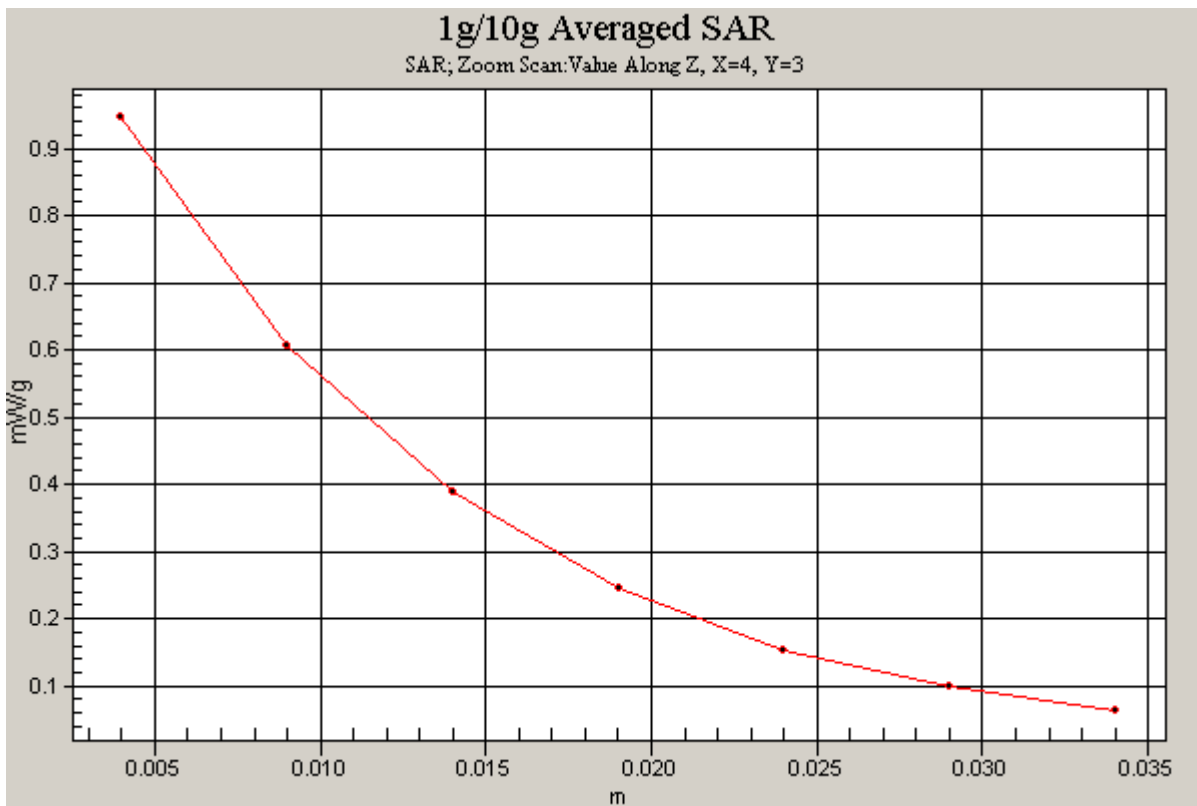

16.5.32 PCS1900-BodyWorn-GPRS-2Slot-Rear-High

Date/Time: 2010-5-19 21:38:18

Test Laboratory: SGS-GSM

PCS 1900-Body-Worn-GPRS-2TS-Rear-High

DUT: KL006; Type: Body&Head; Serial: 3551920011000117

Communication System: PCS1900-GPRS Mode; Frequency: 1909.8 MHz; Duty Cycle: 1:4.15

Medium: HSL 1900 Body Medium parameters used: $f = 1909.8 \text{ MHz}$; $\sigma = 1.53 \text{ mho/m}$; $\epsilon_r = 53.8$; $\rho = 1000 \text{ kg/m}^3$

Phantom section: Flat Section

DASY4 Configuration:

- Probe: ES3DV3 - SN3088; ConvF(4.58, 4.58, 4.58); Calibrated: 2009-11-19
- Sensor-Surface: 4mm (Mechanical Surface Detection)
- Electronics: DAE3 Sn569; Calibrated: 2009-11-18
- Phantom: SAM 12; Type: SAM V4.0; Serial: TP-1283
- Measurement SW: DASY4, V4.7 Build 80; Postprocessing SW: SEMCAD, V1.8 Build 186

Body Worn-High Rear/Area Scan (61x81x1): **Measurement grid: $dx=15\text{mm}$, $dy=15\text{mm}$**

Maximum value of SAR (interpolated) = 0.835 mW/g

Body Worn-High Rear/Zoom Scan (7x7x7)/Cube 0: **Measurement grid: $dx=5\text{mm}$, $dy=5\text{mm}$, $dz=5\text{mm}$**

Reference Value = 7.15 V/m; Power Drift = 0.105 dB

Peak SAR (extrapolated) = 1.22 W/kg

SAR(1 g) = 0.773 mW/g; SAR(10 g) = 0.475 mW/g

Maximum value of SAR (measured) = 0.838 mW/g

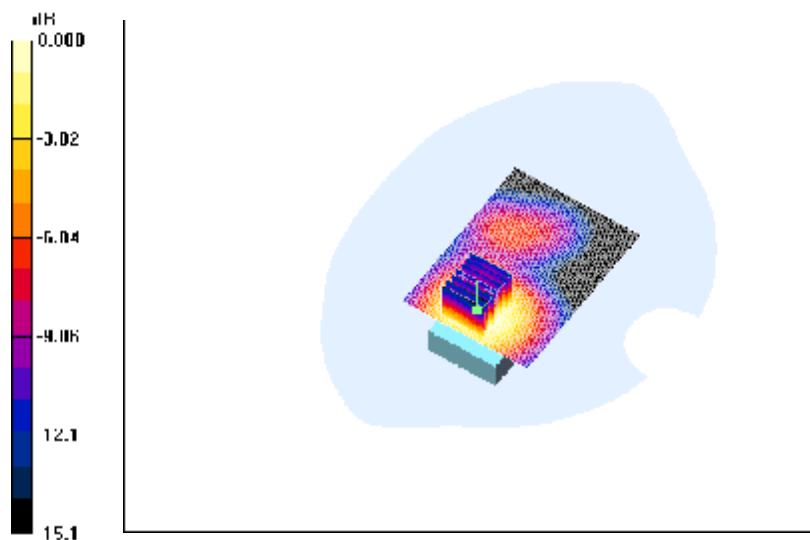

0 dB = 0.838mW/g

SHGSM

16.5.33 PCS1900-BodyWorn-GPRS-Worstcase With Headset

Date/Time: 2010-5-19 22:03:02

Test Laboratory: SGS-GSM

PCS 1900-Body-Worn-GPRS-2TS-Rear-Low With Headset

DUT: KL006; Type: Body&Head; Serial: 3551920011000117

Communication System: PCS1900-GPRS Mode; Frequency: 1850.2 MHz;Duty Cycle: 1:4.15

Medium: HSL 1900 Body Medium parameters used: $f = 1850.2$ MHz; $\sigma = 1.46$ mho/m; $\epsilon_r = 53.9$; $\rho = 1000$ kg/m³

Phantom section: Flat Section

DASY4 Configuration:

- Probe: ES3DV3 - SN3088; ConvF(4.58, 4.58, 4.58); Calibrated: 2009-11-19
- Sensor-Surface: 4mm (Mechanical Surface Detection)
- Electronics: DAE3 Sn569; Calibrated: 2009-11-18
- Phantom: SAM 12; Type: SAM V4.0; Serial: TP-1283
- Measurement SW: DASY4, V4.7 Build 80; Postprocessing SW: SEMCAD, V1.8 Build 186

Body Worn- Low Rear Headset/Area Scan (61x81x1): **Measurement grid: dx=15mm, dy=15mm**

Maximum value of SAR (interpolated) = 0.795 mW/g

Body Worn- Low Rear Headset/Zoom Scan (7x7x7)/Cube 0: **Measurement grid: dx=5mm, dy=5mm, dz=5mm**

Reference Value = 9.35 V/m; Power Drift = 0.131 dB

Peak SAR (extrapolated) = 1.15 W/kg

SAR(1 g) = 0.737 mW/g; SAR(10 g) = 0.449 mW/g

Maximum value of SAR (measured) = 0.806 mW/g

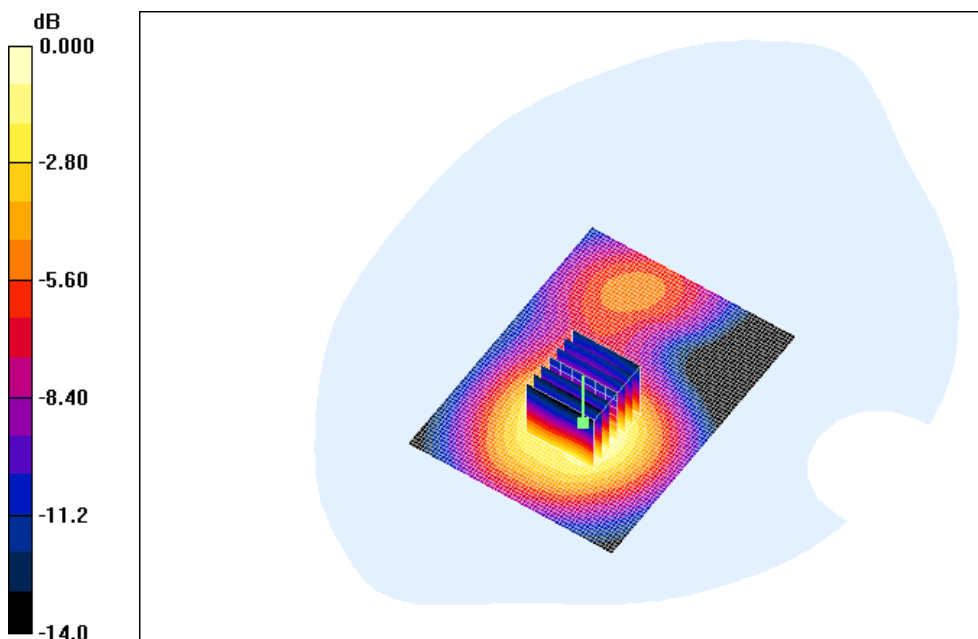

0 dB = 0.806mW/g

SHGSM

16.5.34 PCS1900-BodyWorn-GPRS-Worstcase With Memory

Date/Time: 2010-5-19 22:28:06

Test Laboratory: SGS-GSM

PCS 1900-Body-Worn-GPRS-2TS-Rear-Low With Memory

DUT: KL006; Type: Body&Head; Serial: 3551920011000117

Communication System: PCS1900-GPRS Mode; Frequency: 1850.2 MHz;Duty Cycle: 1:4.15

Medium: HSL 1900 Body Medium parameters used: $f = 1850.2$ MHz; $\sigma = 1.46$ mho/m; $\epsilon_r = 53.9$; $\rho = 1000$ kg/m³

Phantom section: Flat Section

DASY4 Configuration:

- Probe: ES3DV3 - SN3088; ConvF(4.58, 4.58, 4.58); Calibrated: 2009-11-19
- Sensor-Surface: 4mm (Mechanical Surface Detection)
- Electronics: DAE3 Sn569; Calibrated: 2009-11-18
- Phantom: SAM 12; Type: SAM V4.0; Serial: TP-1283
- Measurement SW: DASY4, V4.7 Build 80; Postprocessing SW: SEMCAD, V1.8 Build 186

Body Worn- Low Rear Memory/Area Scan (61x81x1): **Measurement grid: dx=15mm, dy=15mm**

Maximum value of SAR (interpolated) = 0.816 mW/g

Body Worn- Low Rear Memory/Zoom Scan (7x7x7)/Cube 0: **Measurement grid: dx=5mm, dy=5mm, dz=5mm**

Reference Value = 10.1 V/m; Power Drift = 0.104 dB

Peak SAR (extrapolated) = 1.17 W/kg

SAR(1 g) = 0.751 mW/g; SAR(10 g) = 0.457 mW/g

Maximum value of SAR (measured) = 0.811 mW/g

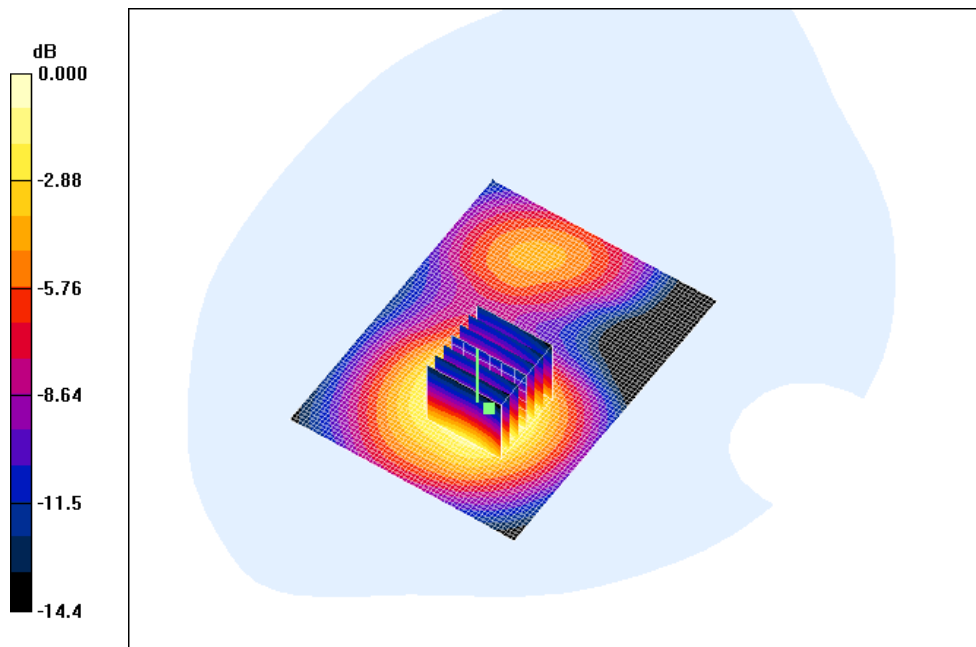

0 dB = 0.811mW/g

SHGSM

17. Identification of Samples

Product Name	GSM Mobile	
Brand Name	LENOVO	
Marketing Name	A332	
Final Hardware Version	Q58_MB_V1.0	
Final Software Version	A332_ve_s0003_100512	
Normal Voltage	3.8V	
Low Voltage	3.5V	
High Voltage	4.2V	
Battery Type	Lenovo BL131	
	1000mAh, 3.7V	
Antenna Type	Inner antenna	
GSM Frequency Bands	GSM850	Tx: 824~849MHz
		Rx: 869~894MHz
	PCS1900	Tx:1850~1910MHz
		Rx:1930~1990MHz
Modulation Mode	GMSK	
GSM / GPRS Power Class	GSM850	4
	PCS1900	1
GPRS Class	Class 10	
Device Class	B	
Reference Number	KL006AI01	
IMEI	3551920011000117	
Date of receipt	05-13,2010	
Date of Testing Start	05-14,2010	
Date of Testing End	05-20,2010	

18. Photographs of EUT



Fig.18-1 Front View



Fig.18-2 Back View



Fig.18-3 Battery



Fig.18-4 Headset

Annex A Photographs of Test Setup

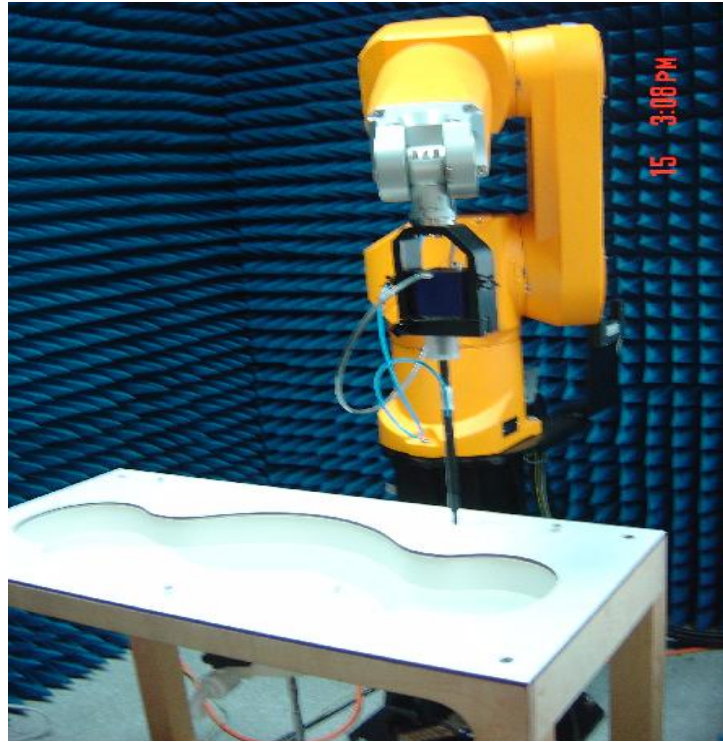

Fig.A-1 Photograph of the SAR measurement System

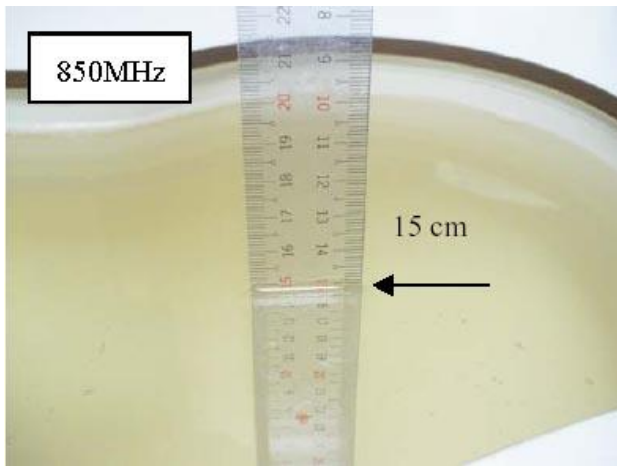

Fig.A-2a Photograph of the Tissue Simulant Liquid depth 15cm for Head

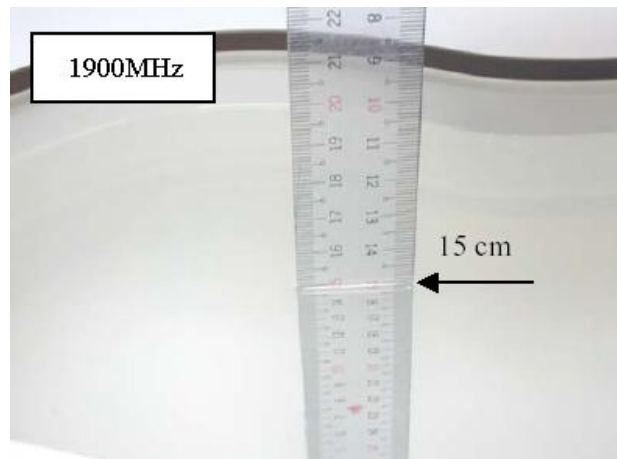

Fig.A-2b Photograph of the Tissue Simulant Liquid depth 15cm for Head

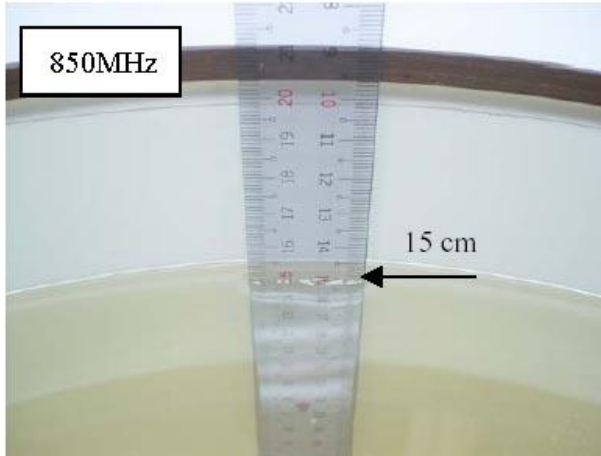

Fig.A-3a Photograph of the Tissue Simulant Liquid depth 15cm for Body Worn

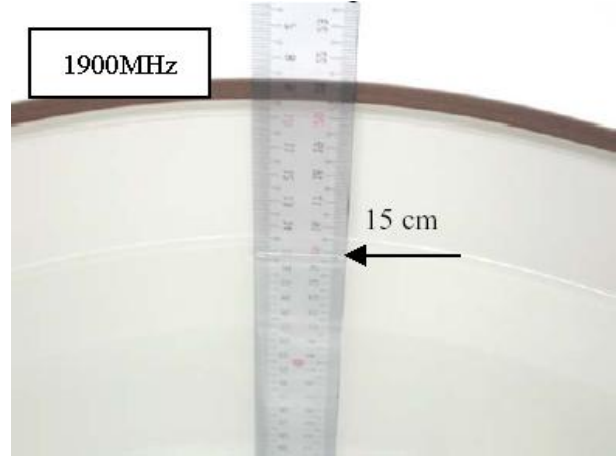

Fig.A-3b Photograph of the Tissue Simulant Liquid depth 15cm for Body Worn

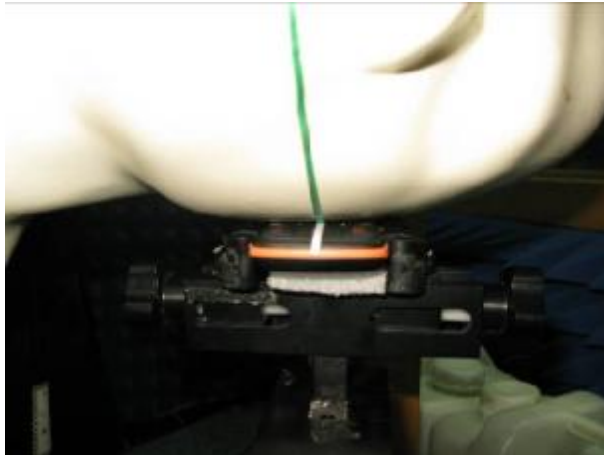
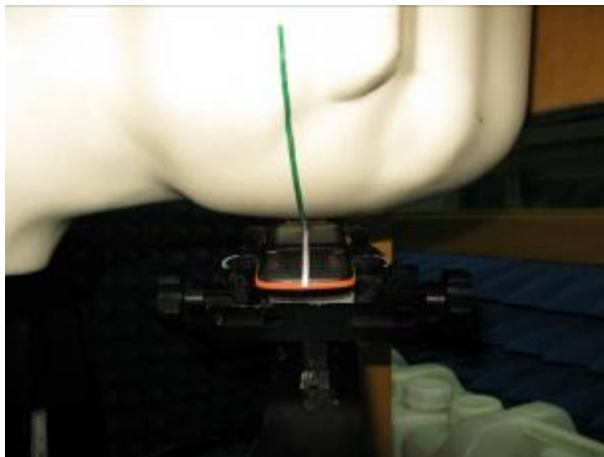

Fig.A-4a Photograph of the Left Hand Side Cheek status



Fig.A-4b Photograph of the Left Hand Side Tilted status



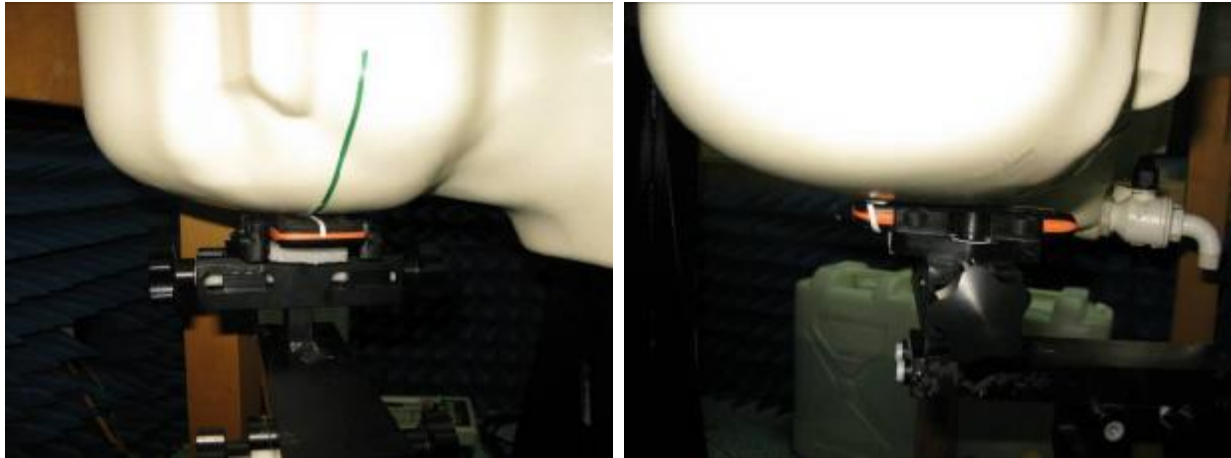

Fig.A-4c Photograph of the Right Hand Side Cheek status

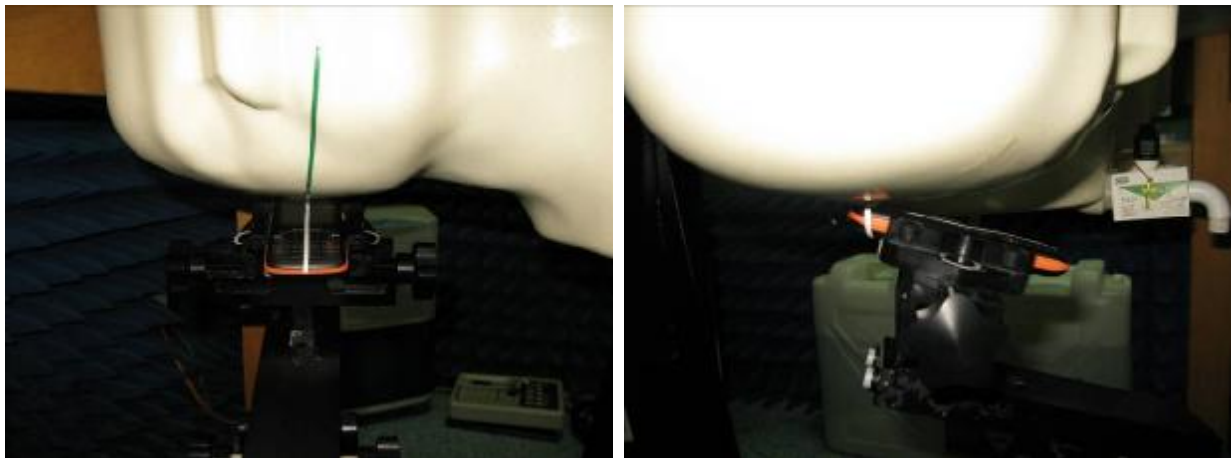

Fig.A-4d Photograph of the Right Hand Side Tilted status



Fig.A-4e Photograph of the Body Worn status



Fig.A-4f Photograph of the Body Worn With Headset status

Annex B Tissue Simulant Liquid

Annex B.1 Recipes for Tissue Simulant Liquid

The following tables give the recipes for tissue simulating liquids to be used in different frequency bands.

Frequency (MHz)	835		900		1800-2000	
Tissue Type	Head	Body	Head	Body	Head	Body
Ingredient (% by weight)						
Water	40.30	50.75	40.30	50.75	55.24	70.17
Salt (NaCl)	1.38	0.94	1.38	0.94	0.31	0.39
Sucrose	57.90	48.21	57.90	48.21	0	0
HEC	0.24	0	0.24	0	0	0
Bactericide	0.18	0.10	0.10	0.10	0	0
DGBE	0	0	0	0	44.45	29.44
Measurement dielectric parameters						
Dielectric Constant	41.9	55.0	41.1	54.5	39.2	53.2
Conductivity (S/m)	0.93	0.97	1.04	1.06	1.45	1.59
Target values						
Dielectric Constant	41.5	55.2	41.5	55.0	40.0	53.3
Conductivity (S/m)	0.90	0.97	0.97	1.05	1.40	1.52
Salt: 99 ⁺ % Pure Sodium Chloride			Sucrose: 98 ⁺ % Pure Sucrose			
Water: De-ionized, 16 MΩ ⁺ resistivity			HEC: Hydroxyethyl Cellulose			
DGBE: 99 ⁺ % Di(ethylene glycol) butyl ether, [2-(2-butoxyethoxy)ethanol]						

Table B-1 Recipe of Tissue Simulat Liquid

Annex B.2 Measurement for Tissue Simulant Liquid

The dielectric properties for this Tissue Simulant Liquids were measured by using the Agilent Model 85070D Dielectric Probe (rates frequency band 200 MHz to 20 GHz) in conjunction with Agilent E5071B Network Analyzer (300 KHz-8500 MHz). The Conductivity (σ) and Permittivity (ρ) are listed in Table 1. For the SAR measurement given in this report. The temperature variation of the Tissue Simulant Liquids was 22±2°C.

Frequency (MHz)	Tissue Type	Limit/Measured	Permittivity (ρ)	Conductivity (σ)	Temp (°C)
835	Head	Recommended Limit	41.5±5% (39.43~43.57)	0.90±5% (0.86~0.94)	22±2
		Measured, 05-13,2010	42.34	0.90	22.3
	Body	Recommended Limit	55.2±5% (52.44~57.96)	0.97±5% (0.92~1.01)	22±2
		Measured, 05-17,2010	55.14	0.97	21.9
1900	Head	Recommended Limit	40±5% (38-42)	1.40±5% (1.33~1.47)	22±2
		Measured, 05-20,2010	38.9	1.42	22.3

	Body	Recommended Limit	53.3±5% (50.64~55.96)	1.52±5% (1.45~1.59)	22±2
		Measured, 05-19,2010	52.7	1.53	22.7

Table B-2 Measurement result of Tissue electric parameters

Annex C SAR System Validation

The microwave circuit arrangement for system verification is sketched in Fig. C-1. The daily system accuracy verification occurs within the flat section of the SAM phantom. A SAR measurement was performed to see if the measured SAR was within +/- 10% from the target SAR values. These tests were done at 835&1900MHz. The tests were conducted on the same days as the measurement of the EUT. The obtained results from the system accuracy verification are displayed in the table C-1 (A power level of 250mw was input to the dipole antenna). During the tests, the ambient temperature of the laboratory was in the range 22°C, the relative humidity was in the range 60% and the liquid depth above the ear reference points was above 15 cm in all the cases. It is seen that the system is operating within its specification, as the results are within acceptable tolerance of the reference values.

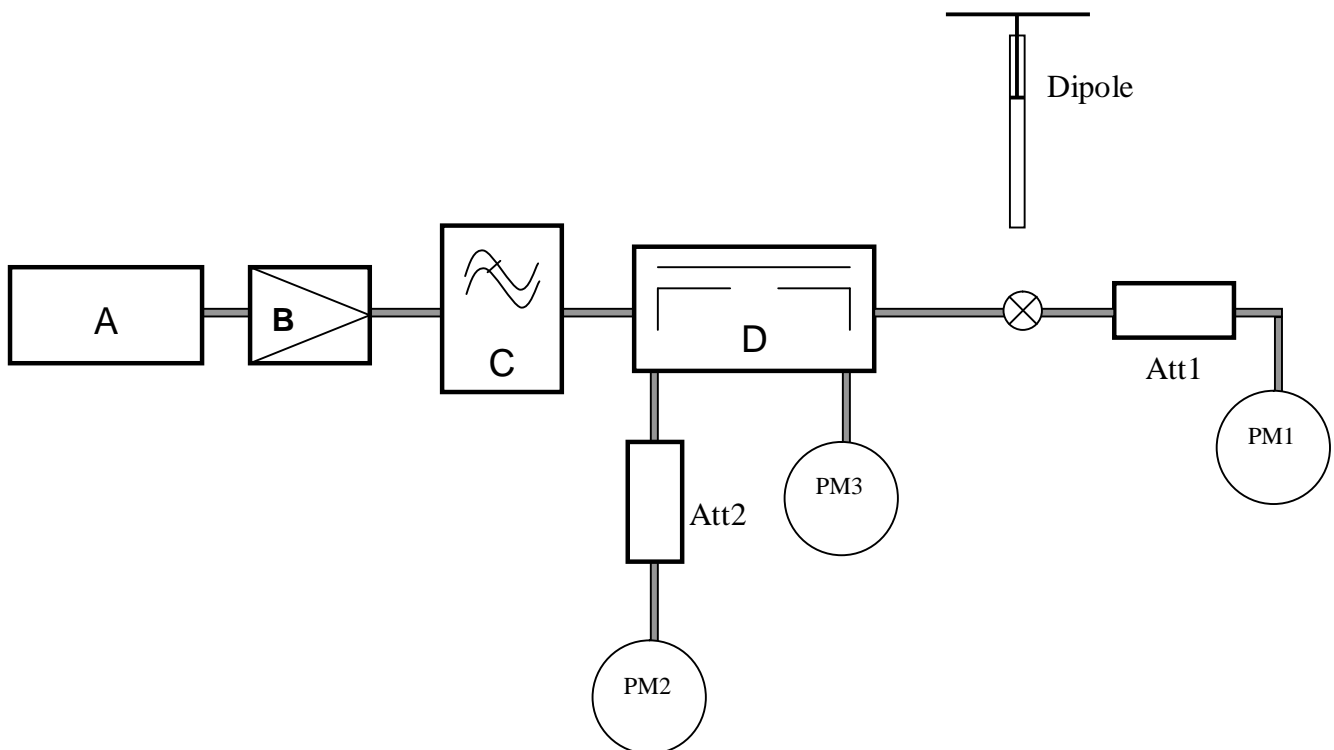

Fig. C-1 the microwave circuit arrangement used for SAR system verification

- A. Agilent E4438C Signal Generator
- B. Mini-Circuit ZHL-42 Preamplifier
- C. Mini-Circuit VLF-2500+ Low Pass Filter

D. Mini-Circuits ZABDC20-252H-N+ Bi-DIR Coupling

PM1. Power Sensor NRP-Z92

PM2. Agilent Model E4416A Power Meter

PM3. Power Sensor NRP-Z92

Validation Kit	Frequency (MHz)	Tissue Type	Limit/Measurement		
			Condition	Recommended/Measured	1g
D835V2	835	Head	Nomalized to 1mW(for nominal Head TSL parameters)	Recommended Limit	9.62±10% (8.66-10.58)
			Nomalized to 1W(for nominal Head TSL parameters)	-	9.72
			250mW input power	Measured, 05-13, 2010	2.42
		Body	Nomalized to 1mW(for nominal Head TSL parameters)	Recommended Limit	9.89±10% (8.90-10.87)
			Nomalized to 1W(for nominal Head TSL parameters)	-	10.04
			250mW input power	Measured, 05-17, 2010	2.51
D1900V2	1900	Head	Nomalized to 1W(for nominal Head TSL parameters)	Recommended Limit	39.3±10% (35.37-43.23)
			Nomalized to 1W(for nominal Head TSL parameters)	-	41
			250mW input power	Measured, 05-20, 2010	10.4
		Body	Nomalized to 1mW(for nominal Head TSL parameters)	Recommended Limit	40.4±10% (36.36-44.44)
			Nomalized to 1W(for nominal Head TSL parameters)	-	42.53
			250mW input power	Measured, 05-19, 2010	10.7

Table C-1 SAR System Validation Result

System Validation for 835MHz-Head

Date/Time: 2010-5-13 16:50:34

Test Laboratory: SGS-GSM

System-Validation-D835-Head

DUT: Dipole 835MHz; Type: D835V2; Serial: D835V2 - SN:4d070

Communication System: CW; Frequency: 835 MHz; Duty Cycle: 1:1

Medium: HSL835_Head Medium parameters used: $f = 835 \text{ MHz}$; $\sigma = 0.894 \text{ mho/m}$; $\epsilon_r = 42.5$; $\rho = 1000 \text{ kg/m}^3$

Phantom section: Flat Section

DASY4 Configuration:

- Probe: ES3DV3 - SN3088; ConvF(5.84, 5.84, 5.84); Calibrated: 2009-11-19
- Sensor-Surface: 4mm (Mechanical Surface Detection)
- Electronics: DAE3 Sn569; Calibrated: 2009-11-18
- Phantom: SAM 12; Type: SAM V4.0; Serial: TP-1283
- Measurement SW: DASY4, V4.7 Build 80; Postprocessing SW: SEMCAD, V1.8 Build 186

$d=15\text{mm}$, $P_{in}=250\text{mW}$ /Area Scan (61x121x1): **Measurement grid: $dx=15\text{mm}$, $dy=15\text{mm}$**

Maximum value of SAR (interpolated) = 2.57 mW/g

$d=15\text{mm}$, $P_{in}=250\text{mW}$ /Zoom Scan (7x7x7) (7x7x7)/Cube 0: **Measurement grid: $dx=5\text{mm}$, $dy=5\text{mm}$, $dz=5\text{mm}$**

Reference Value = 54.4 V/m; Power Drift = -0.049 dB

Peak SAR (extrapolated) = 3.69 W/kg

SAR(1 g) = 2.42 mW/g; SAR(10 g) = 1.56 mW/g

Maximum value of SAR (measured) = 2.62 mW/g

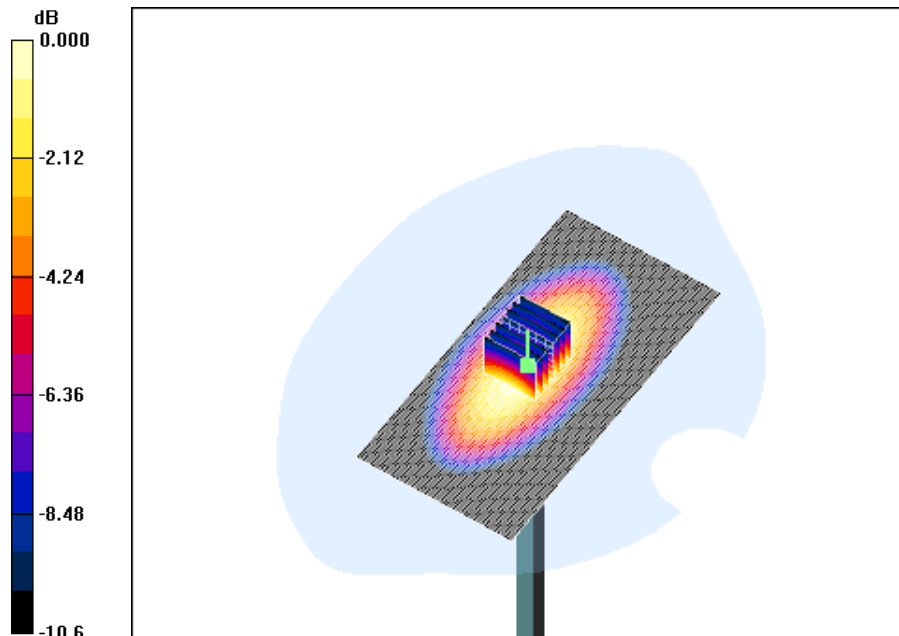

0 dB = 2.62mW/g

SHGSM

System Validation for 835MHz-Body

Date/Time: 2010-5-17 13:32:36

Test Laboratory: SGS-GSM

System-Validation-D835-Body

DUT: Dipole 835MHz; Type: D835V2; Serial: D835V2 - SN:4d070

Communication System: CW; Frequency: 835 MHz; Duty Cycle: 1:1

Medium: HSL835 Body Medium parameters used: $f = 835 \text{ MHz}$; $\sigma = 0.958 \text{ mho/m}$; $\epsilon_r = 55.2$; $\rho = 1000 \text{ kg/m}^3$

Phantom section: Flat Section

DASY4 Configuration:

- Probe: ES3DV3 - SN3088; ConvF(5.68, 5.68, 5.68); Calibrated: 2009-11-19
- Sensor-Surface: 4mm (Mechanical Surface Detection)
- Electronics: DAE3 Sn569; Calibrated: 2009-11-18
- Phantom: SAM 12; Type: SAM V4.0; Serial: TP-1283
- Measurement SW: DASY4, V4.7 Build 80; Postprocessing SW: SEMCAD, V1.8 Build 186

$d=15\text{mm}$, $P_{in}=250\text{mW}$ /Area Scan (61x121x1): **Measurement grid: $dx=15\text{mm}$, $dy=15\text{mm}$**

Maximum value of SAR (interpolated) = 2.70 mW/g

$d=15\text{mm}$, $P_{in}=250\text{mW}$ /Zoom Scan (7x7x7) (7x7x7)/Cube 0: **Measurement grid: $dx=5\text{mm}$, $dy=5\text{mm}$, $dz=5\text{mm}$**

Reference Value = 52.0 V/m; Power Drift = -0.202 dB

Peak SAR (extrapolated) = 3.73 W/kg

SAR(1 g) = 2.51 mW/g; SAR(10 g) = 1.65 mW/g

Maximum value of SAR (measured) = 2.71 mW/g

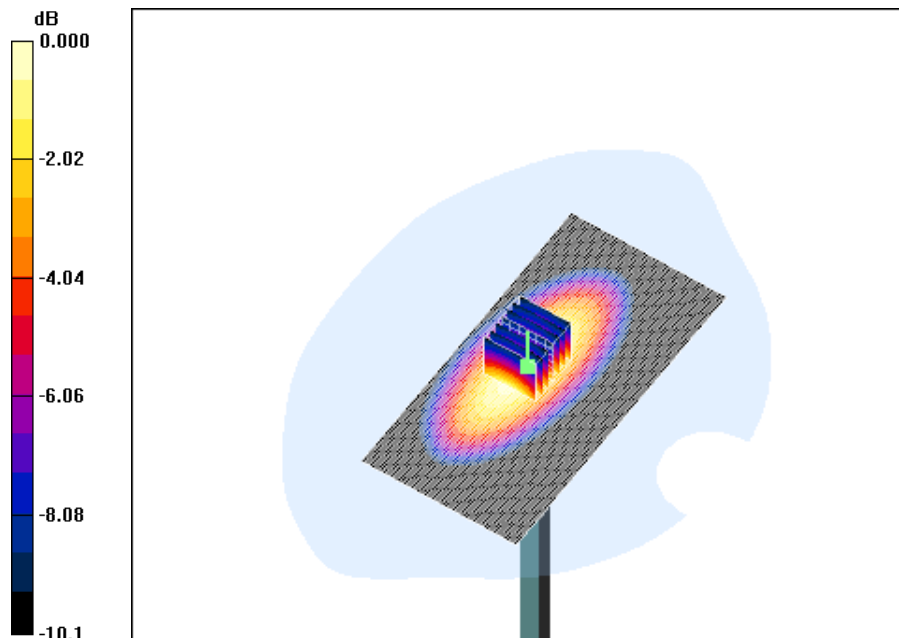

0 dB = 2.71mW/g

SHGSM

System Validation for 1900MHz-Head

Date/Time: 2010-5-20 10:40:18

Test Laboratory: SGS-GSM

System-Validation-D1900-Head

DUT: Dipole 1900 MHz; Type: D1900V2; Serial: D1900V2 - SN:5d028

Communication System: CW; Frequency: 1900 MHz; Duty Cycle: 1:1

Medium: HSL1900_Head Medium parameters used: $f = 1900$ MHz; $\sigma = 1.42$ mho/m; $\epsilon_r = 38.9$; $\rho = 1000$ kg/m³

Phantom section: Flat Section

DASY4 Configuration:

- Probe: ES3DV3 - SN3088; ConvF(4.97, 4.97, 4.97); Calibrated: 2009-11-19
- Sensor-Surface: 4mm (Mechanical Surface Detection)
- Electronics: DAE3 Sn569; Calibrated: 2009-11-18
- Phantom: SAM 12; Type: SAM V4.0; Serial: TP-1283
- Measurement SW: DASY4, V4.7 Build 80; Postprocessing SW: SEMCAD, V1.8 Build 186

d=10mm, Pin=250mW/Area Scan (61x101x1): Measurement grid: dx=15mm, dy=15mm

Maximum value of SAR (interpolated) = 12.4 mW/g

d=10mm, Pin=250mW/Zoom Scan (7x7x7) (7x7x7)/Cube 0: Measurement grid: dx=5mm, dy=5mm, dz=5mm

Reference Value = 89.2 V/m; Power Drift = -0.044 dB

Peak SAR (extrapolated) = 19.7 W/kg

SAR(1 g) = 10.4 mW/g; SAR(10 g) = 5.32 mW/g

Maximum value of SAR (measured) = 11.7 mW/g

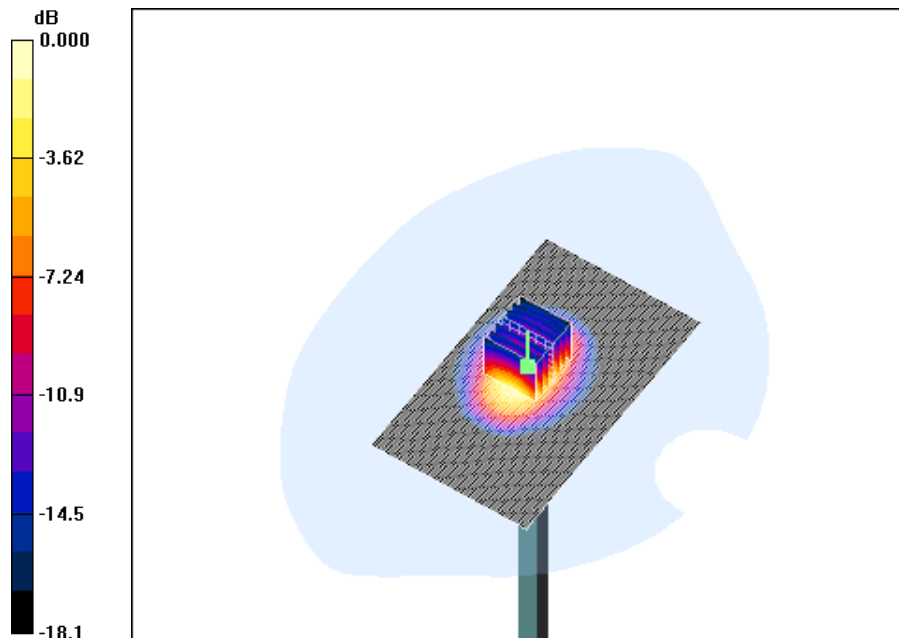

0 dB = 11.7mW/g

SHGSM

System Validation for 1900MHz-Body

Date/Time: 2010-5-19 14:26:37

Test Laboratory: SGS-GSM

System-Validation-D1900-Body

DUT: Dipole 1900 MHz; Type: D1900V2; Serial: D1900V2 - SN:5d028

Communication System: CW; Frequency: 1900 MHz; Duty Cycle: 1:1

Medium: HSL 1900 Body Medium parameters used: $f = 1900 \text{ MHz}$; $\sigma = 1.53 \text{ mho/m}$; $\epsilon_r = 53.8$; $\rho = 1000 \text{ kg/m}^3$

Phantom section: Flat Section

DASY4 Configuration:

- Probe: ES3DV3 - SN3088; ConvF(4.58, 4.58, 4.58); Calibrated: 2009-11-19
- Sensor-Surface: 4mm (Mechanical Surface Detection)
- Electronics: DAE3 Sn569; Calibrated: 2009-11-18
- Phantom: SAM 12; Type: SAM V4.0; Serial: TP-1283
- Measurement SW: DASY4, V4.7 Build 80; Postprocessing SW: SEMCAD, V1.8 Build 186

$d=10\text{mm}$, $P_{in}=250\text{mW}$ /Area Scan (61x101x1): **Measurement grid: $dx=15\text{mm}$, $dy=15\text{mm}$**

Maximum value of SAR (interpolated) = 12.5 mW/g

$d=10\text{mm}$, $P_{in}=250\text{mW}$ /Zoom Scan (7x7x7) (7x7x7)/Cube 0: **Measurement grid: $dx=5\text{mm}$, $dy=5\text{mm}$, $dz=5\text{mm}$**

Reference Value = 82.9 V/m; Power Drift = -0.026 dB

Peak SAR (extrapolated) = 18.0 W/kg

SAR(1 g) = 10.5 mW/g; SAR(10 g) = 5.64 mW/g

Maximum value of SAR (measured) = 11.9 mW/g

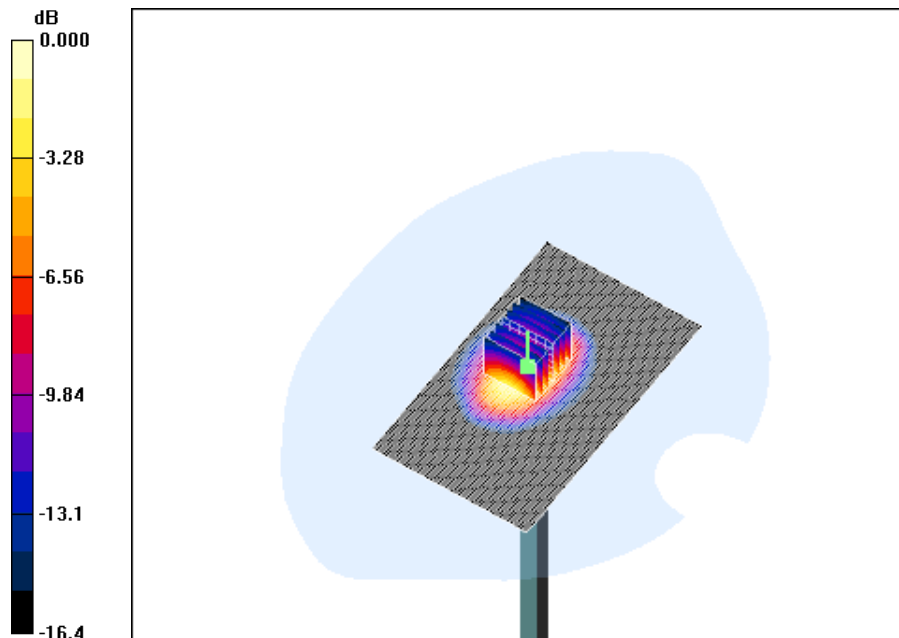

0 dB = 11.9mW/g

SHGSM