

EMI TEST REPORT

FCC CERTIFICATION / ISED

Applicant:

PITTASOFT CO., LTD.

7F, BYC HIGHCITY Building A 131, Gasan Digital1-ro,
Geumcheon-gu, Seoul, Republic of Korea, 08506

Date of Issue: April 10, 2019

Test Report No. HCT-EM-1903-FI003-R1

Test Site: HCT CO., LTD.

**FCC ID
IC**

**YCK-B-124X
23402-B124X**

Rule Part(s) / Standard(s) : FCC CFR 47 PART 15 Subpart B Class B
ICES-003 Issue 6 Class B
ANSI C63.4-2014

EUT Type : Rechargeable Li-ion Battery

Model Name : B-124X

Date of Test : March 07, 2019 / March 21, 2019

The device bearing the trade name and model specified above, has been shown to comply with the applicable technical standards as indicated in the measurement report and was tested in accordance with the measurement procedures specified in ANSI C63.4-2014. (See Test Report if any modifications were made for compliance)

I attest to the accuracy of data. All measurements reported herein were performed by me or were made under my supervision and are correct to the best of my knowledge and belief. I assume full responsibility for the completeness of these measurements and vouch for the qualifications of all persons taking them.

HCT certifies that no party to application has been denied the FCC benefits pursuant to Section 5301 of the Anti-Drug Abuse Act of 1988, 21 U.S.C 862

Tested By



Kyoung-Hee Yoon
Test Engineer
EMC Team
Certification Division

Reviewed



Jin-Pyo Hong
Technical Manager
EMC Team
Certification Division

This report only responds to the tested sample and may not be reproduced, except in full, without written approval of the HCT Co., Ltd.



REVISION HISTORY

The revision history for this document is shown in table.

Report No.	Issue Date	Information About Changes
HCT-EM-1903-FI003	March 28, 2019	Initial Release
HCT-EM-1903-FI003-R1	April 10, 2019	Added core (Clause 3.3, Charging mode)



TABLE OF CONTENTS

	PAGE
1. GENERAL INFORMATION	4
1.1 Description of EUT	4
1.2 Tested System Details	4
1.3 Cable Description	5
1.4 Noise Suppression Parts on Cable. (I/O Cable)	5
1.5 Test Facility	6
1.6 Calibration of Measuring Instrument	6
1.7 Measurement Uncertainty	6
2. LIST OF TEST EQUIPMENT	7
3. DESCRIPTION OF TEST	8
3.1 Measurement of Conducted Emission	8
3.2 Measurement of Radiated Emission	9
4. OPERATING MODES	11
4.1 Conducted Emission	11
4.2 Radiated Emission	11
5. CONDUCTED AND RADIATED EMISSION TEST SUMMARY	12
5.1 Conducted Emission (Not Applicable)	12
5.2 Radiated Emission	13
6. CONCLUSION	20
7. APPENDIX A. TEST SETUP PHOTOGRAPHS	21



1. GENERAL INFORMATION

1.1 Description of EUT

Its basic purpose is used for communications.

FCC ID	YCK-B-124X
IC	23402-B124X
Model	B-124X
EUT Type	Rechargeable Li-ion Battery
Frequency Band	Bluetooth: 2 402 MHz to 2 480 MHz (TX/RX)
Power Voltage	12 VDC, 24 VDC
Manufacturer	EGEN Inc. 61, Dongtangiheung-ro, Dongtan-myeon, Hwaseong-si, Gyeonggi-do, Korea

1.2 Tested System Details

All equipment descriptions used in the tested system (including inserted cards) are:

Device Type	Model Name	Serial Number	Manufacturer
EUT	B-124X	-	EGEN
Extended battery	LiFePO4	-	PITTASOFT
Cigarette charge	-	-	PITTASOFT
39 ohm LED load	-	-	-
4 Ω load	-	-	-



1.3 Cable Description

Product Name	Port	Power Cord Shielded (Y/N)	I/O Cable Shielded (Y/N)	Length (m)
EUT	DC IN (Cigarette)	N	N/A	(P) 1.5
	DC IN (Hardwire)	N	N/A	(P) 3.0
	DC IN/OUT	N	N/A	(P) 0.33
	DC OUT	N	N/A	(P) 0.3
	USB	N	N/A	(P) 0.2

* The marked “(D)” means the data cable and “(P)” means the power cable.

1.4 Noise Suppression Parts on Cable. (I/O Cable)

Product Name	Port	Ferrite Bead (Y/N)	Location	Metal Hood (Y/N)	Location
EUT	DC IN (Cigarette)	Y	EUT END	Y	Both End
	DC IN (Hardwire)	Y	EUT END	Y	Both End
	DC IN/OUT	N	N/A	Y	Both End
	DC OUT	Y	EUT END	Y	Both End
	USB	Y	EUT END	Y	Both End



1.5 Test Facility

Test site is located at 74, SEOICHEON-RO, 578BEON-GIL, MAJANG-MYEON, ICHEON-SI, GYEONGGI-DO, SOUTH KOREA. Those measurement facilities are constructed in conformance with the requirements of ANSI C63.4-2014. The Normalized site attenuations (30 MHz to 1 GHz) and Site validation (1 GHz to 18 GHz) were performed in accordance with the standard in ANSI C63.4-2014

Measurement Facilities	Registration Number
Radiated Field strength measurement facility 3 m Semi Anechoic chamber	90661
Radiated Field strength measurement facility 10 m Semi Anechoic chamber	
Filing the EMI Measurement Facility (3 m Semi Anechoic Chamber and Shielded Room)	IC 5944A-4
Filing the EMI Measurement Facility (10 m Semi-Anechoic Chamber)	IC 5944A-2

1.6 Calibration of Measuring Instrument

The measuring equipment, which was utilized in performing the tests documented herein, has been calibrated in accordance with the manufacturers recommendations for utilizing calibration equipments, which is traceable to recognized national standards.

Especially, all antenna for measurement is calibrated in accordance with the requirements of C63.5 (Version : 2006).

1.7 Measurement Uncertainty

The measurement uncertainties shown below were calculated in accordance with the requirements of ANSI C63.4-2014.

All measurement uncertainty values are shown with a coverage factor of $k = 2$ to indicate a 95 % level of confidence. The measurement data shown herein meets or exceeds the U_{CISPR} measurement uncertainty values specified in CISPR 16-4-2 and, thus, can be compared directly to specified limits to determine compliance.

Parameter	Expanded Uncertainty (dB)
Conducted Emission (0.15 MHz to 30 MHz)	1.82 dB
Radiated Emissions (30 MHz to 1 GHz)	5.20 dB
Radiated Emissions (1 GHz to 18 GHz)	5.24 dB
Radiated Emissions (18 GHz to 40 GHz)	5.40 dB



2. LIST OF TEST EQUIPMENT

<u>Type</u>	<u>Manufacturer</u>	<u>Model Name</u>	<u>Serial Number</u>	<u>Calibration Cycle</u>	<u>CAL Date</u>
<u>Conducted Emission</u>					
<input type="checkbox"/> EMI Test Receiver	Rohde & Schwarz	ESCI	100584	1 year	06.25.2018
<input type="checkbox"/> EMI Test Receiver	Rohde & Schwarz	ESCI	100033	1 year	06.27.2018
<input type="checkbox"/> LISN	Rohde & Schwarz	ENV216	102245	1 year	12.12.2018
<input type="checkbox"/> LISN	Rohde & Schwarz	ENV216	100073	1 year	05.03.2018
<input type="checkbox"/> Software	Rohde & Schwarz	EMC32 VER8.54.0	-	-	-
<u>Radiated Emission</u>					
-For measurement below 1 GHz					
<input type="checkbox"/> EMI Test Receiver	Rohde & Schwarz	ESU40	100524	1 year	07.27.2018
<input type="checkbox"/> Trilog Antenna	Schwarzbeck	VULB 9168	760	2 year	04.06.2017
<input type="checkbox"/> Antenna master	INNCO Systems	MA4640-XP-ET	-	N/A	-
<input type="checkbox"/> Antenna master controller	INNCO Systems	CO 3000	CO3000/870/ 35990515/L	N/A	-
<input type="checkbox"/> Turn Table	INNCO Systems	1060	-	N/A	-
<input type="checkbox"/> Turn Table controller	INNCO Systems	CO2000	CO2000/095/ 7590304/L	N/A	-
<input type="checkbox"/> EMI Test Receiver	Rohde & Schwarz	ESU26	100241	1 year	08.14.2018
<input checked="" type="checkbox"/> EMI Test Receiver	Rohde & Schwarz	ESU40	100361	1 year	10.11.2018
<input checked="" type="checkbox"/> Trilog Antenna	Schwarzbeck	VULB 9168	847	2 year	04.13.2018
<input checked="" type="checkbox"/> Antenna master	INNCO Systems	MA4000-EP	-	N/A	-
<input checked="" type="checkbox"/> Turn Table	INNCO Systems	DT6000/3000-5T	-	N/A	-
<input checked="" type="checkbox"/> Software	Rohde & Schwarz	EMC32 VER8.40.0	-	-	-
-For measurement above 1 GHz					
<input checked="" type="checkbox"/> EMI Test Receiver	Rohde & Schwarz	ESU40	100524	1 year	07.27.2018
<input checked="" type="checkbox"/> Antenna master	INNCO Systems	MA4640-XP-ET	-	N/A	-
<input checked="" type="checkbox"/> Antenna master controller	INNCO Systems	CO3000	CO3000/870/ 35990515/L	N/A	-
<input checked="" type="checkbox"/> Turn Table	INNCO Systems	1060-2M	-	N/A	-
<input checked="" type="checkbox"/> Turn Table controller	INNCO Systems	CO2000	CO2000/095/ 7590304/L	N/A	-
<input checked="" type="checkbox"/> Horn Antenna	Schwarzbeck	BBHA 9120D	01836	2 year	07.20.2018
<input checked="" type="checkbox"/> Low Noise Amplifier	TESTEK	TK-PA18H	170034-L	1 year	03.04.2019
<input type="checkbox"/> Horn Antenna	Schwarzbeck	BBHA 9170	BBHA9170#786	2 year	12.05.2017
<input type="checkbox"/> Power Amplifier	TESTEK	TK-PA1840H	170030-L	1 year	12.17.2018
<input type="checkbox"/> Antenna master controller	HD GmbH	HD 100	100/637	N/A	-
<input type="checkbox"/> Power Amplifier	CERNEX	CBLU1183540	21691	1 year	06.25.2018
<input type="checkbox"/> Antenna master	HD GmbH	MA240	240/520	N/A	-
<input type="checkbox"/> EMI Test Receiver	Rohde & Schwarz	ESU26	100241	1 year	08.14.2018
<input type="checkbox"/> Turn Table	INNCO Systems	DT3000-3T	DT3000/69	N/A	-
<input checked="" type="checkbox"/> Software	Rohde & Schwarz	EMC32 VER8.40.0	-	-	-



3. DESCRIPTION OF TEST

3.1 Measurement of Conducted Emission

The test procedure was in accordance with ANSI C63.4-2014, Clause 7.3

- a. The EUT was placed 0.4 meters from the conducting wall of the shielded room with EUT being connected to the power mains through a line impedance stabilization network (LISN).
 If the EUT is connected to the PC through USB, the AC power-line adapter of the PC is directly connected to a line impedance stabilization network (LISN).
 Other support units were connected to the power mains through another LISN. The two LISNs provide 50 Ohm/ 50uH of coupling impedance for the measuring instrument.
- b. Both conducted lines are measured in Quasi-Peak and Average mode, including the worst-case data points for each tested configuration.
- c. The frequency range from 150 kHz to 30 MHz was searched.

[Conducted Emission Limit]

Frequency (MHz)	Resolution Bandwidth (kHz)	Class A		Class B	
		Quasi-Peak (dBμV)	Average (dBμV)	Quasi-Peak (dBμV)	Average (dBμV)
0.15 to 0.5	9	79	66	66 to 56*	56 to 46*
0.5 to 5	9	73	60	56	46
5 to 30	9	73	60	60	50

**Decreases with the logarithm of the frequency.*



3.2 Measurement of Radiated Emission

The test procedure was in accordance with ANSI C63.4-2014, Clause 8.3

- a. The EUT was placed on the top of a turn table 0.8 meters above the ground at a semi-anechoic chamber. The table was rotated 360 degrees to determine the position of the highest radiation.
- b. The EUT was set 3 m away from the interference-receiving antenna, which was mounted on the top of a variable-height antenna tower.
- c. The antenna height is varied from 1 m to 4 m above the ground to determine the maximum value of the field strength. Both horizontal and vertical polarizations of the antenna are set to make the measurement.
- d. For each suspected emission, the EUT was arranged to its worst case and then the antenna was tuned to heights from 1 m to 4 m and the turn table was turned from 0 degrees to 360 degrees to find the maximum reading.
- e. The test-receiver system was set to Quasi-Peak detect function and specified bandwidth with maximum hold mode when the test frequency is below 1 GHz.
- f. The test-receiver system was set to Peak and Average detect function and specified bandwidth with maximum hold mode when the test frequency is above 1 GHz.
- g. Place the measurement antenna away from each area of the EUT determined to be a source of emissions at the specified measurement distance, while keeping the measurement antenna aimed at the source of emissions at each frequency of significant emissions, with polarization oriented for maximum response.(1 GHz to 40 GHz)

[Radiated Emission Limits]

Frequency (MHz)	Class A			Class B		
	Antenna Distance (m)	Field Strength ($\mu\text{V/m}$)	Quasi-Peak ($\text{dB}\mu\text{V/m}$)	Antenna Distance (m)	Field Strength ($\mu\text{V/m}$)	Quasi-Peak ($\text{dB}\mu\text{V/m}$)
30 to 88	10	90	39.0	3	100	40.0
88 to 216	10	150	43.5	3	150	43.5
216 to 960	10	210	46.4	3	200	46.0
Above 960	10	300	49.5	3	500	54.0
Frequency (MHz)	Antenna Distance (m)	Class A		Class B		
		Peak ($\text{dB}\mu\text{V/m}$)	Average ($\text{dB}\mu\text{V/m}$)	Peak ($\text{dB}\mu\text{V/m}$)	Average ($\text{dB}\mu\text{V/m}$)	
Above 1 000	3	80	60	74	54	



3.2.1 Frequency Range of Radiated Measurements

An unintentional radiator, including a digital device, the spectrum shall be investigated from the lowest radio frequency signal generated or used in the device, without going below the lowest frequency for which a Radiated Emission limit is specified, up to the frequency shown in the following table

Highest frequency generated or used in the device or on which the device operates or tunes (MHz)	Upper frequency of measurement range (MHz)
Below 1.705	30
1.705 to 108	1 000
108 to 500	2 000
500 to 1 000	5 000
Above 1 000	5 th harmonic of the highest frequency or 40 GHz, whichever is lower

3.3 Configuration of Tested System

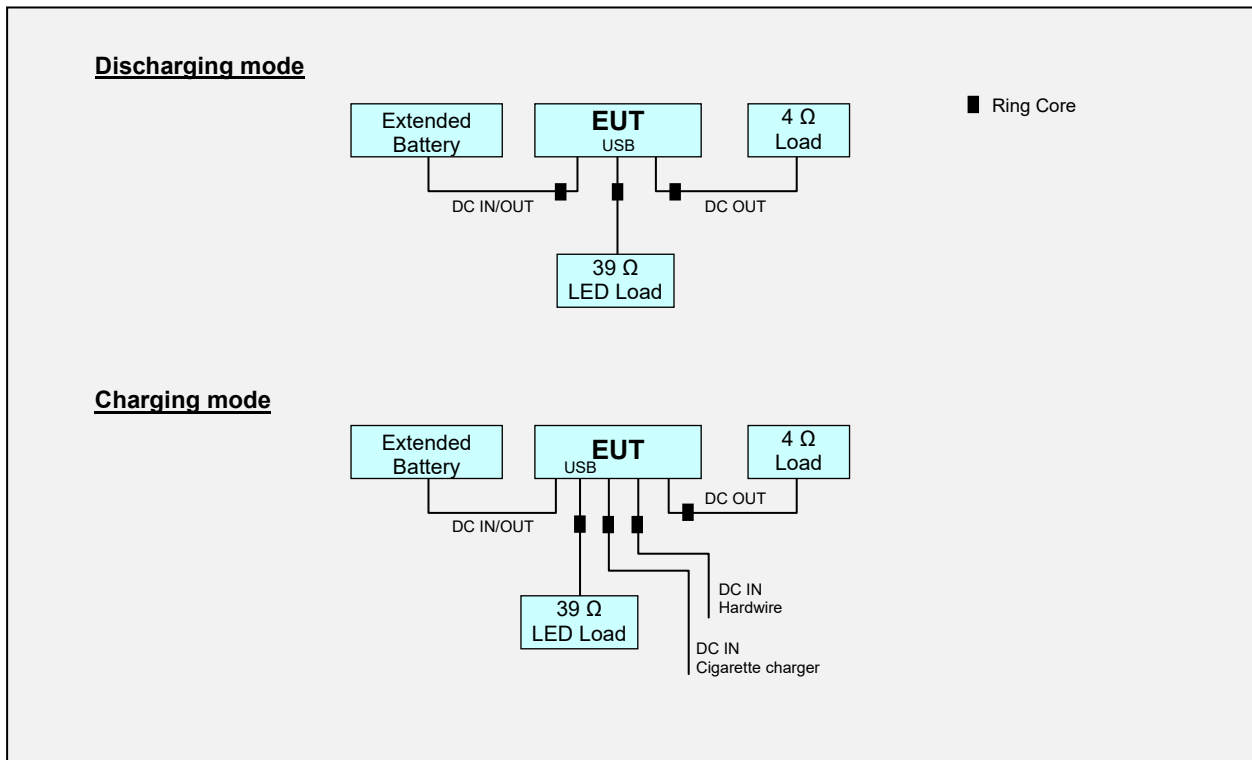

Non-Conductive Table
 Power Line: 120 VAC, 60 Hz



4. PRELIMINARY TEST

4.1 Conducted Emission

It was tested the following operating mode, after connecting all peripheral devices.

Operating Modes: Not applicable

NOTE.

This equipment is a device that uses DC voltage, so we did not test the conducted emission test.

4.2 Radiated Emission

It was tested the following operating mode, after connecting all peripheral devices.

Operating Modes:

Charging + Bluetooth Idle mode (Hardwire path)

Charging + Bluetooth Idle mode (Cigarette charger path)

Discharging Bluetooth Idle mode

NOTE.

1. Three orientations have been investigated and the worst case orientation is reported.
2. All modes of operation were verified and the worst case configuration result was indicated in the test report.



5. CONDUCTED AND RADIATED EMISSION TEST SUMMARY

5.1 Conducted Emission (Not Applicable)

The test results of conducted emission at mains ports provide the following information:

Rule Part / Standard	FCC PART 15 Subpart B Class B ICES-003 Issue 6 Class B ANSI C63.4-2014
Detector	Quasi-Peak, CISPR-Average
Bandwidth	9 kHz (6 dB)
Kind of Test Site	Shielded Room
Temperature	- °C
Relative Humidity	- %
Test Date	-

NOTE.

This equipment is a device that uses DC voltage, so we did not test the conducted emission test.



5.2 Radiated Emission

The test results of radiated emission provide the following information:

For Measurement Below 1 GHz

Rule Part / Standard	FCC PART 15 Subpart B Class B ICES-003 Issue 6 Class B ANSI C63.4-2014
Detector	Quasi-Peak
Bandwidth	120 kHz (6 dB)
Measurement Distance	3 m
Kind of Test Site	3 m semi anechoic chamber
Temperature	23.0 °C
Relative Humidity	43.1 %
Test Date	March 21, 2019

- Calculation Formula:

1. POL. H = Horizontal, POL. V = Vertical
2. QuasiPeak = Reading (Receiver Reading) + Corr.
3. Corr. (Correction Factor) = Antenna Factor + Cable Loss
4. Margin = Limit - QuasiPeak



DISCHARGING mode

Frequency (MHz)	Quasi Peak (dBμV/m)	Antenna Height (cm)	POL. (H/V)	Azimuth (deg)	Corr. (dB)	Margin (dB)	Limit (dBμV/m)
107.476800	33.3	207.9	H	23.0	16.3	10.2	43.5
107.483200	33.5	174.9	H	209.0	16.3	10.0	43.5
110.525600	34.0	206.9	H	211.0	16.6	9.5	43.5
110.534400	34.6	174.9	H	34.0	16.6	8.9	43.5
112.556000	35.2	174.8	H	200.0	16.8	8.3	43.5
153.103200	27.9	225.1	H	78.0	20.0	15.6	43.5

12 V_Charging + Bluetooth Idle mode (Hardwire path)

Frequency (MHz)	Quasi Peak (dBμV/m)	Antenna Height (cm)	POL. (H/V)	Azimuth (deg)	Corr. (dB)	Margin (dB)	Limit (dBμV/m)
86.800800	30.6	193.7	H	211.0	14.8	9.4	40.0
111.474400	39.4	175.0	H	223.0	16.7	4.1	43.5
121.564000	34.6	225.1	H	26.0	17.8	8.9	43.5
145.891200	31.9	209.7	H	26.0	19.9	11.6	43.5
185.329600	37.3	99.8	V	0.0	18.2	6.2	43.5
314.334400	36.8	99.7	H	140.0	20.9	9.2	46.0

24 V_Charging + Bluetooth Idle mode (Hardwire path)

Frequency (MHz)	Quasi Peak (dBμV/m)	Antenna Height (cm)	POL. (H/V)	Azimuth (deg)	Corr. (dB)	Margin (dB)	Limit (dBμV/m)
109.512800	34.3	225.2	H	24.0	16.5	9.2	43.5
112.551200	32.8	174.8	H	23.0	16.8	10.7	43.5
188.454400	36.4	99.8	V	1.0	17.9	7.1	43.5
289.548000	38.8	99.8	H	99.0	20.2	7.2	46.0
336.270400	36.7	99.8	H	287.0	21.3	9.3	46.0
352.085600	37.7	99.8	H	300.0	21.7	8.3	46.0
924.749600	31.7	99.8	H	297.0	31.5	14.3	46.0



12 V_ Charging + Bluetooth Idle mode (Cigarette charger path)

Frequency (MHz)	Quasi Peak (dBµV/m)	Antenna Height (cm)	POL. (H/V)	Azimuth (deg)	Corr. (dB)	Margin (dB)	Limit (dBµV/m)
85.160800	31.3	208.8	H	203.0	15.1	8.7	40.0
97.398400	36.9	191.9	H	206.0	15.1	6.6	43.5
109.510400	40.3	225.1	H	26.0	16.5	3.2	43.5
122.696000	31.6	174.9	H	213.0	18.0	11.9	43.5
196.739200	31.8	99.8	V	106.0	17.1	11.7	43.5
313.540000	37.3	99.7	H	118.0	20.8	8.7	46.0

24 V_ Charging + Bluetooth Idle mode (Cigarette charger path)

Frequency (MHz)	Quasi Peak (dBµV/m)	Antenna Height (cm)	POL. (H/V)	Azimuth (deg)	Corr. (dB)	Margin (dB)	Limit (dBµV/m)
153.112000	35.6	99.8	V	118.0	20.0	7.9	43.5
154.150400	36.6	99.8	V	91.0	20.1	6.9	43.5
155.131200	36.1	99.7	V	111.0	20.1	7.4	43.5
311.162400	39.5	99.8	H	98.0	20.8	6.5	46.0
335.354400	37.5	99.8	H	109.0	21.3	8.5	46.0
351.670400	36.5	99.8	H	118.0	21.7	9.5	46.0



For Measurement Above 1 GHz

Rule Part / Standard	FCC PART 15 Subpart B Class B ICES-003 Issue 6 Class B ANSI C63.4-2014
Detector	Peak mode: Peak (RBW: 1 MHz, VBW: 3 MHz) CISPR-Average mode: Peak (RBW: 1 MHz, VBW: 10 Hz)
Highest Frequency	2 480 MHz
Tested Frequency Range	1 GHz to 18 GHz
Measurement Distance	3 m
Kind of Test Site	3 m semi anechoic chamber
Temperature	24.2 °C
Relative Humidity	40.5 %
Test Date	March 07, 2019

- Calculation Formula:

1. POL. H = Horizontal, POL. V = Vertical
2. Peak or CAverage = Reading (Receiver Reading) + Corr.
3. Corr. (Correction Factor) = Antenna Factor+ Cable Loss –Amplifier Gain
4. Margin = Limit - Peak or CAverage



DISCHARGING mode

Frequency (MHz)	Peak (dBμV/m)	Antenna Height (cm)	POL. (H/V)	Azimuth (deg)	Corr. (dB)	Margin (dB)	Limit (dBμV/m)
1702.865000	30.8	149.6	V	247.0	-20.0	43.2	74.0
3845.180000	34.9	99.7	H	0.0	-15.0	39.1	74.0
5950.445000	38.2	99.7	H	117.0	-8.5	35.8	74.0
6896.000000	41.3	150.0	H	113.0	-5.2	32.7	74.0
9794.195000	46.2	99.9	H	0.0	-0.2	27.8	74.0
10863.500000	48.6	249.9	H	198.0	3.1	25.4	74.0

Frequency (MHz)	CAverage (dBμV/m)	Antenna Height (cm)	POL. (H/V)	Azimuth (deg)	Corr. (dB)	Margin (dB)	Limit (dBμV/m)
1702.865000	18.2	149.6	V	247.0	-20.0	35.8	54.0
3845.180000	22.5	99.7	H	0.0	-15.0	31.5	54.0
5950.445000	25.3	99.7	H	117.0	-8.5	28.7	54.0
6896.000000	28.1	150.0	H	113.0	-5.2	25.9	54.0
9794.195000	33.5	99.9	H	0.0	-0.2	20.5	54.0
10863.500000	35.3	249.9	H	198.0	3.1	18.7	54.0



12 V_ Charging + Bluetooth Idle mode (Hardwire path)

Frequency (MHz)	Peak (dBμV/m)	Antenna Height (cm)	POL. (H/V)	Azimuth (deg)	Corr. (dB)	Margin (dB)	Limit (dBμV/m)
1083.960000	35.3	218.4	V	54.0	-21.7	38.7	74.0
1883.615000	30.4	203.4	V	45.0	-19.8	43.6	74.0
2970.195000	33.4	160.5	H	89.0	-16.9	40.6	74.0
5590.055000	37.4	204.6	V	180.0	-9.3	36.6	74.0
7697.335000	42.5	99.8	V	322.0	-3.3	31.5	74.0
9903.075000	45.7	113.6	H	0.0	-0.1	28.3	74.0

Frequency (MHz)	CAverage (dBμV/m)	Antenna Height (cm)	POL. (H/V)	Azimuth (deg)	Corr. (dB)	Margin (dB)	Limit (dBμV/m)
1083.960000	22.8	218.4	V	54.0	-21.7	31.2	54.0
1883.615000	17.7	203.4	V	45.0	-19.8	36.3	54.0
2970.195000	20.8	160.5	H	89.0	-16.9	33.2	54.0
5590.055000	24.6	204.6	V	180.0	-9.3	29.4	54.0
7697.335000	30.2	99.8	V	322.0	-3.3	23.8	54.0
9903.075000	33.0	113.6	H	0.0	-0.1	21.0	54.0

24 V_ Charging + Bluetooth Idle mode (Hardwire path)

Frequency (MHz)	Peak (dBμV/m)	Antenna Height (cm)	POL. (H/V)	Azimuth (deg)	Corr. (dB)	Margin (dB)	Limit (dBμV/m)
1803.690000	31.3	203.4	V	136.0	-19.9	42.7	74.0
3511.735000	34.5	190.5	V	0.0	-15.6	39.5	74.0
4656.515000	36.5	244.5	V	340.0	-12.1	37.5	74.0
7373.050000	42.1	199.4	V	204.0	-3.9	31.9	74.0
9824.380000	46.0	249.9	V	42.0	-0.2	28.0	74.0
10875.700000	48.0	199.4	H	350.0	3.1	26.0	74.0

Frequency (MHz)	CAverage (dBμV/m)	Antenna Height (cm)	POL. (H/V)	Azimuth (deg)	Corr. (dB)	Margin (dB)	Limit (dBμV/m)
1803.690000	18.0	203.4	V	136.0	-19.9	36.0	54.0
3511.735000	21.9	190.5	V	0.0	-15.6	32.1	54.0
4656.515000	24.0	244.5	V	340.0	-12.1	30.0	54.0
7373.050000	29.1	199.4	V	204.0	-3.9	24.9	54.0
9824.380000	33.3	249.9	V	42.0	-0.2	20.7	54.0
10875.700000	35.2	199.4	H	350.0	3.1	18.8	54.0



12 V_ Charging + Bluetooth Idle mode (Cigarette charger path)

Frequency (MHz)	Peak (dBμV/m)	Antenna Height (cm)	POL. (H/V)	Azimuth (deg)	Corr. (dB)	Margin (dB)	Limit (dBμV/m)
1116.360000	37.4	149.6	V	28.0	-27.3	36.6	74.0
3046.815000	35.3	99.9	V	198.0	-21.0	38.7	74.0
4949.405000	38.9	249.7	V	0.0	-16.1	35.1	74.0
7027.450000	44.3	99.7	V	68.0	-10.8	29.7	74.0
9461.150000	48.5	150.1	V	100.0	-5.5	25.5	74.0
10857.925000	48.0	111.4	V	27.0	-2.9	26.0	74.0

Frequency (MHz)	CAverage (dBμV/m)	Antenna Height (cm)	POL. (H/V)	Azimuth (deg)	Corr. (dB)	Margin (dB)	Limit (dBμV/m)
1116.360000	25.9	149.6	V	28.0	-27.3	28.1	54.0
3046.815000	22.6	99.9	V	198.0	-21.0	31.4	54.0
4949.405000	26.0	249.7	V	0.0	-16.1	28.0	54.0
7027.450000	31.0	99.7	V	68.0	-10.8	23.0	54.0
9461.150000	35.5	150.1	V	100.0	-5.5	18.5	54.0
10857.925000	35.3	111.4	V	27.0	-2.9	18.7	54.0

24 V_ Charging + Bluetooth Idle mode (Cigarette charger path)

Frequency (MHz)	Peak (dBμV/m)	Antenna Height (cm)	POL. (H/V)	Azimuth (deg)	Corr. (dB)	Margin (dB)	Limit (dBμV/m)
1073.950000	36.1	189.6	V	311.0	-27.5	37.9	74.0
1717.215000	34.0	149.9	V	255.0	-25.5	40.0	74.0
6124.300000	39.0	150.0	V	339.0	-14.2	35.0	74.0
7328.245000	43.8	99.8	V	50.0	-9.9	30.2	74.0
9493.170000	48.9	149.5	H	250.0	-5.4	25.1	74.0
10966.395000	47.9	99.7	V	0.0	-2.7	26.1	74.0

Frequency (MHz)	CAverage (dBμV/m)	Antenna Height (cm)	POL. (H/V)	Azimuth (deg)	Corr. (dB)	Margin (dB)	Limit (dBμV/m)
1073.950000	25.8	189.6	V	311.0	-27.5	28.2	54.0
1717.215000	20.3	149.9	V	255.0	-25.5	33.7	54.0
6124.300000	26.5	150.0	V	339.0	-14.2	27.5	54.0
7328.245000	31.2	99.8	V	50.0	-9.9	22.8	54.0
9493.170000	35.7	149.5	H	250.0	-5.4	18.3	54.0
10966.395000	35.6	99.7	V	0.0	-2.7	18.4	54.0



6. CONCLUSION

The data collected shows that the **EUT Type: Rechargeable Li-ion Battery, Model: B-124X** complies with §15.107 and §15.109 of the FCC rules and ICES-003 Issue 6 of the IC rules.



7. APPENDIX A. TEST SETUP PHOTOGRAPHS

Please refer to Annex. A