

GTI-ATM2022-X Module

Extreme Low Power Bluetooth 5.0 SoC Module

Datasheet

Rev 1.0-Nov 02, 2020

Revision history

Date	Revision	Board Rev	Section/ page	Description
Nov 02, 2020	Rev 1.0			

Index

1.	General Description	4
2.	Key Features	4
3.	Specifications	6
4.	Applications.....	8
5.	SoC block diagram.....	9
6.	Module block diagram	10
7.	Module picture	11
8.	PCB placement and dimensions.....	12
9.	Pin Description.....	14
10.	Maximum Electrical Ratings	15
11.	Recommended Operating condition	15
12.	Radio Transceiver Characteristics (VCC=3.0V Temperature =27°C).....	16
13.	Wakeup Receiver Characteristics	16
14.	GPIO Characteristics.....	17
15.	Embedded Flash Characteristics	17
16.	Power consumption	17
17.	PMU configuration.....	18
18.	BT5.0 BLE RF Performance test	19
19.	Design notes.....	20
20.	Evaluation board -EVb/ DVB	21
21.	Recommended Reflow Profile	22
22.	Package.....	23
23.	Contacts.....	25

1. General Description

The GTI-ATM2022-X module is an extreme low-power Bluetooth® 5 system-on-a-chip (SoC) solution. This innovative module design is based on the extremely low power Atmosic M2 Series Bluetooth wireless platform. The GTI-ATM2022-X design incorporates several innovative features that have a dramatic impact on extending the battery life of edge-of-network connected IoT products. This Bluetooth SIG certified Bluetooth Low Energy SoC integrates a Bluetooth 5.0 compliant radio with an ARM® Cortex® M0 application processor, 128 KB, 512 KB or 1MB embedded Flash, 128 KB Random Access Memory (RAM), 256 KB Read-Only Memory (ROM), 4 KB One-Time-Programmable (OTP) memory, and state-of-the-art power management.

The extremely low power ATM2 series SoC with 900uA active Rx and 2.4 mA active Tx full system power and has been designed to extend battery life for the Internet-of-Things (IoT) applications. Support for low duty cycle operation allows systems to run for significantly longer time periods without battery replacement

2. Key Features

- Compliant with Bluetooth 5.0 standard
- Supports Bluetooth 2 Mbps, 1 Mbps
- Fully integrated RF front-end
- Incorporates a second specialized Wake Up Receiver (WURx) can run with the system in hibernate mode using less than 850nA in place of beaconing
- Smart sensor hub with out of bounds exception handling that can run in hibernate mode in conjunction with the Wake-Up Receiver
- SoC typical power consumption with 3 V battery including PMU
 - - Active Rx @ -95 dBm: 900 uA
 - - Active Tx @ 0 dBm: 2.4 mA
 - - Retention @ 32 KB RAM: 2 µA
 - - Hibernation with Wakeup Receiver: 0.95 µA
 - - Hibernate: 0.8 µA
 - - Soc Off: 300 nA
- CPU: 16 MHz ARM Cortex M0 processor, programmable interrupt router
- Memory: 128 KB, 512 KB or 1 MB embedded Flash, 256 KB ROM, 128 KB RAM, and 4 KB OTP
- Retention RAM configuration: 16 KB to 128 KB in 16 KB step sizes
- Interfaces: I2C, SPI, UART, GPIO
- 10-bit application ADC ([Note #1](#))
- Digital microphone Input (PDM) ([Note #1](#))
- 32.768 kHz/16 MHz crystal oscillator
- SWD for interactive debugging
- AES 128 hardware
- True random number generator (TRNG)
- Smart Sensor Hub ([Note #1](#))

- Keyboard matrix controller (KSM) (*Note #1*)
- Quadrature decoder for mouse input (QDEC) (*Note #1*)
- 32.768 kHz/16 MHz crystal oscillator
- 1.1 V to 3.3 V battery input voltage with integrated Power Management Unit (PMU)

Note#1: This module is made to perform the very best of Bluetooth 5.0 functions with extremely low power. Although there are diversities of other features in the SoC which are remained in this module but are beyond the scope of this datasheet.

3. Specifications

Radio Transceiver

- Typical -94dbm RX sensitivity(255-byte packets,1 Mbps LE)
- TX output power from -20 dBm to +4 dBm

True single-chip BLE Soc Solution

- Integrated BLE radio
- Supports OTA programming mechanism for firmware upgrade
- Complete BLE protocol stack and application profiles
- Supports both master and slave modes
- Supports 2 Mbps LE
- Frequency bands: 2402 MHz to 2480 MHz
- GFSK modulation format

Very low power consumption

- Single 1.1V to 3.3V power supply
- Integrated DC-DC and LDO
- 0.85 uA power-down mode(Wakeup by Receiver)
- 2.0 uA deep sleep mode (32KHz RO on,160k SRAM in retention state)
- 900 uA Rx and 2.4 mA Tx current @0 dBm Tx power with DC-DC
- 4.0 mA Tx current @4 dBm Tx power with DC-DC

Module Size 14.0 X 8.5 X 2.0 mm ±0.3 mm PCB SMD

High-level integration

- 6 channel, 10 bit ADC
- 32 KHz sleep timer
- programmable PWM
- 1 channel SPI interface
- 1 channel UART interface
- 1 channel I2C master interface
- AES128 security coprocessor

Memory

- Internal 1MB embedded Flash, 128KB RAM and 256KB ROM

The embedded flash memory size is factory optional as below

Part number	Embedded Flash Memory size
GTI-ATM2022-1M	1MB
GTI-ATM2022-512	512KB
GTI-ATM2022-128	128KB

4. Applications

Industrial and Enterprise

- Beacons
- Remote Sensors
- Environmental Monitors

Healthcare

- Asset Trackers
- Locating
- Wearables

Home

- Home Automation
- Remote Control
- Human Interface Devices (HID)
- Entertainment

Smart Cities

- Asset Trackers
- Beacons

Personal

- Gaming
- Wearables

Auto

- Key fobs and Accessories
- Infotainment

5. SoC block diagram

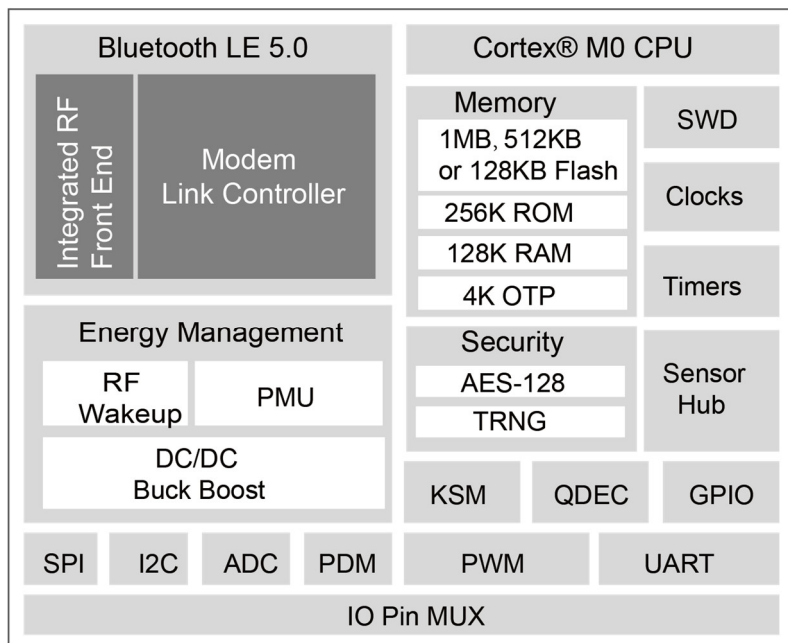

6. Module block diagram

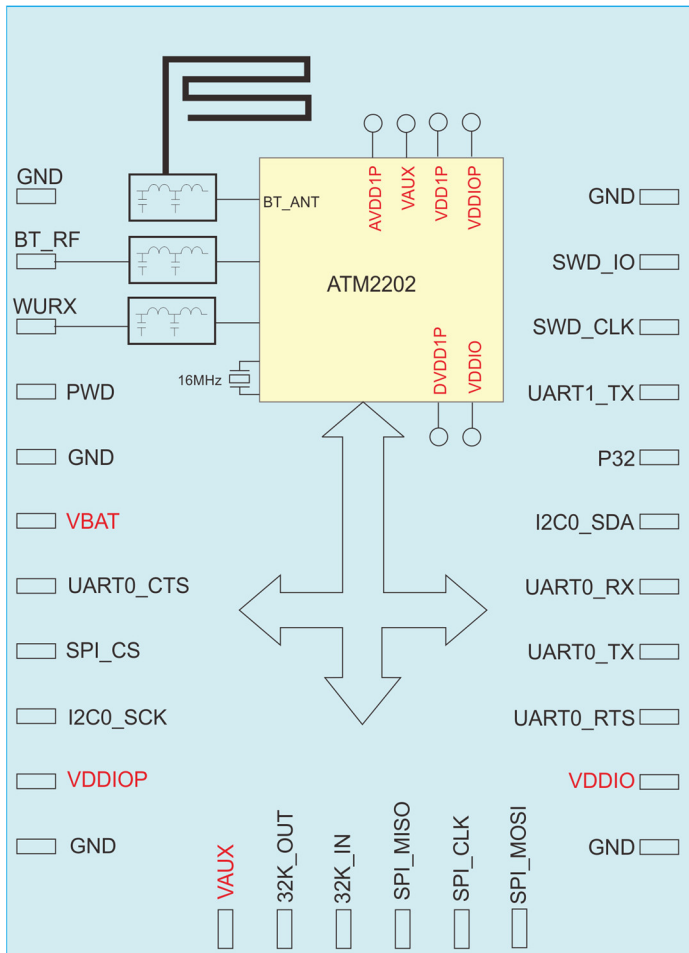

7. Module picture

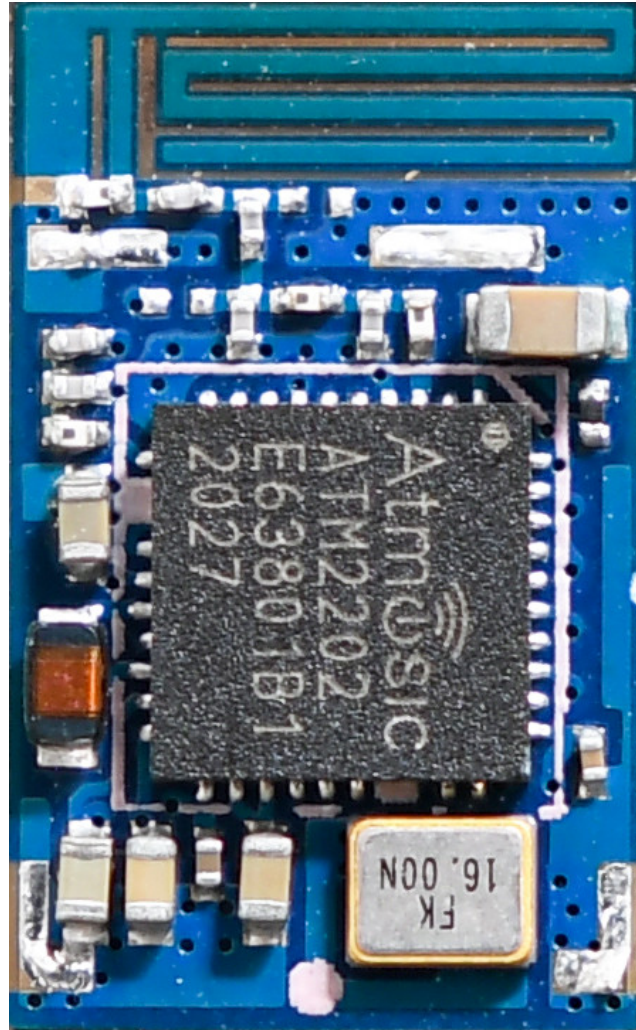

8. PCB placement and dimensions

■ Top View

RF signal is connected to the on board PCB trace antenna through L1 (see section-19)

The 2nd route of RF signal is connected to pin2 through R1 (see section-19)

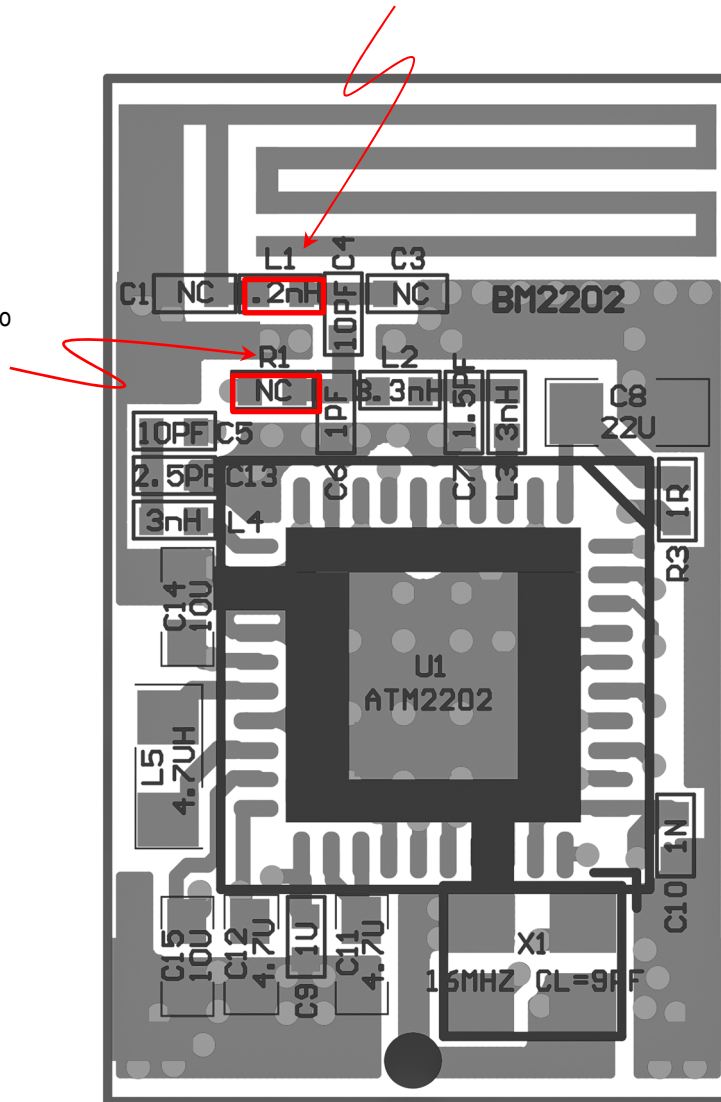

■ Bottom View (unit: mm)

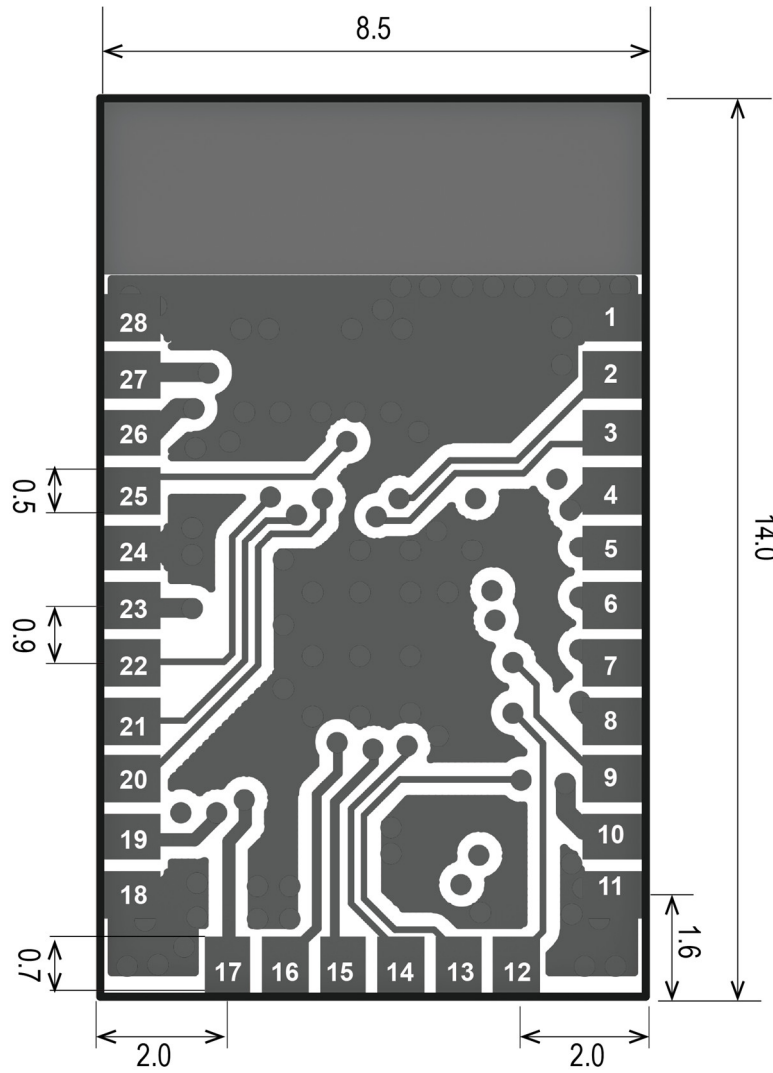

9. Pin Description

Pin	Pin name	I/O	Description	GPIO
1	GND	PWR	Power and signal ground	
2	BT_RF	RF	2.4 GHz Single-ended RF I/O for Bluetooth radio	
3	WURX	RF	Wake receiver RF input, connect to ext. antenna	
4	PWD	I/O	Power Down Input (Active High)	
5	GND	PWR	Power and signal ground	
6	VBAT	PWR Input	Battery Power Supply (DC 1.1 to 3.3V)	
7	UART0_CTS	I/O	UART0_CTS	P11
8	SPI_CS	I/O	SPIC_S	P10
9	I2C0_SCL	I/O	I2C0_SCL	P9
10	VDDIOP	PWR Output	1.8 V I/O power supply generated by SoC, connect to VAUX if unused (See section 17 PMU configuration)	
11	GND	PWR	Power and signal ground	
12	VAUX	PWR	Reserved for switching regulator internal use	
13	32K_OUT	A	32.768 kHz crystal oscillator output	
14	32K_IN	A	32.768 kHz crystal oscillator input	
15	SPI_MISO	I/O	SPI_MISO	P13
16	SPI_CLK	I/O	SPI_CLK	P20
17	SPI_MOSI	I/O	SPI_MOSI	P22
18	GND	PWR	Power and signal ground	
19	VDDIO	PWR Input	Power supply Input for digital I/O (See section 17 PMU configuration)	
20	UART0_RTS	I/O	UART0_RTS	P24
21	UART0_TX	I/O	UART0_TX	P23
22	UART0_RX	I/O	UART0_RX	P25
23	I2C0_SDA	I/O	I2C0_SDA	P30
24	P32	I/O	UART1_RX	P32
25	UART1_TX	I/O	UART1_TX	P33
26	SWD_CLK	I/O	SWD_CLK -Serial Wire Debugger	P1
27	SWD_IO	I/O	SWD_IO-Serial Wire Debugger	P2
28	GND	PWR	Power and signal ground	

10. Maximum Electrical Ratings

Symbol	Parameter	Min.	Typ	Max.	Unit
VBAT	Battery supply	-0.2		3.4	V
VDDIO	I/O supply	-0.2		3.4	V
VIO	I/O pin	-0.2		3.4	V
VRF	RF I/O pin (BT_RF, WURX)			10	V
ESD (HBM)	ESD HBM class 2			2000	V
ESD (CDM)	ESD CDM			500	V
T-store	Storage Temperature	-40		125	°C

Note: ESD(HBM) for TMC and PWD pins are 1250V

11. Recommended Operating condition

Operating Condition		Min.	Typ	Max.	Unit
OP-tempering temperature range	Operating Temperature range	-40	25	85	°C
Relative Humidity				85	%
VDDIO	I/O supply	1.7	1.8	3.3	V
VBAT	Battery supply	1.1		3.3	V
VPP25	OTP Programming Voltage	2.3	2.5	2.7	V
VIO	I/O pin voltage level	-0.2		VIO+0.2	V
32K-OSC	Crystal OSC-32.768KHz	-500		500	ppm

Note:

1. VBAT minimum supply after boot is 1.0V
2. VBAT minimum slew rate is 0.3V/ms
3. VPP25 is physically connected to VDDIO. Set VDDIO to within VPP25 range when programming the OTP.

12. Radio Transceiver Characteristics (VCC=3.0V Temperature =27°C)

Parameter	Conditions	Min.	Typical	Max.	Units
Frequency range		2.402		24.80	GHz
Rx sensitivity	37-byte packets, clean Tx				
	125 kbps		-101		dBm
	500 kbps		-98.5		dBm
	1 Mbps		-95		dBm
	2 Mbps		-93		dBm
	255-byte packets, dirty Tx				
	125 kbps		-100		dBm
	500 kbps		-96.5		dBm
1 Mbps		-94		dBm	
2 Mbps		-91		dBm	
Tx output power	4, 2, 0, -2, -4, -6, -10, -20	-20		4	dBm
Tx power accuracy			+/- 1.5		dB
Tx spectral mask @ 1M sym/s	2 MHz offset	-20			dBm
	> 3 MHz offset	-30			dBm
Rx Carrier-to-Interferer (LE 1M PHY)	Co-channel interference	21		-100	dB
	Adjacent 1 MHz interference	15			dB
	Adjacent 2 MHz interference	-17			dB
	Adjacent 3 MHz interference	-27			dB

13. Wakeup Receiver Characteristics

Parameter	Conditions	Min.	Typ	Max.	Units
Sensitivity (>= 90% wakeup success rate)	2440 MHz, 14-byte packets at 1 ms interval for 40 ms		-44		dBm

14. GPIO Characteristics

Parameter	Conditions	Min.	Typ	Max.	Units
Input VIL		-0.2	0	0.2	V
Output VOH	2 mA Load		VIO-0.2		V
Output VOL	2 mA Load		0.2		V

15. Embedded Flash Characteristics

Parameter	Conditions	Min.	Typ	Max.	Units
Endurance	Program/Erase	100,000			Cycles
Data Retention			20		Year

16. Power consumption

VBAT current at 3 V with internally generated IO supply

Parameter	Conditions	Min.	Typ	Max.	Units
Active RX	Sensitivity at -95 dBm 1 mA		1		mA
Active TX @ 4 dBm	Output power at 4 dBm		4		mA
Active TX @ 0 dBm	Output power at 0 dBm		2.5		mA
Active TX @ -10 dBm	Output power at -10 dBm		1.4		mA
Powerdown	PWD pin asserted		75		nA
Retention (32 KB RAM)			2		μA
Hibernation			0.8		μA
Hibernation with Wakeup Receiver			0.95		μA
SoC Off			300		nA

17. PMU configuration

There is a PMU (Power Management Unit) inside the SoC chip, below is the description of these power rails.

Power rail	Pin on module	Input/Output	description
VBAT	6	I	Battery or External Power Supply (DC 1.1 to 3.3V)
VDDIO	19	I	Power input for digital and analog I/O
VDDIOP	10	O	1.8V IO power output generated by PMU
VAUX	12	O	The auxiliary power output of typical 3.2V used internally by the PMU

The PMU must be configured correctly to ensure correct operation. The following rules must be followed.

1. Use external VDDIO power supply
(One external power supply or battery with external IO supply)
 - VBAT to external power or battery
 - Connect VBAT to VDDIO
 - Connect VAUX to VDDIOP
 - Disable IO supply generation ([Note #2](#))

2. Use the internal VDDIO power supply
(one external power supply or battery with internally generated IO supply)
This is for the application that can use an internal 1.8V IO supply for better power consumption or $VBAT \leq 1.8V$
 - VBAT to external power or battery
 - Connect VDDIOP to VDDIO

Note #2: Internal I/O supply VDDIOP can be disabled in firmware by controlling the register `opt_disable_vddio`, and it will not be discussed here. The internal I/O supply is enabled by default.

18. BT5.0 BLE RF Performance test

Sample under test: GTI-ATM2022-1M

Test machine: IQ2011

Data rate: 1Mbps

Item channel packet type	No.	Tx power (-20 to 20dBm)			Frequency offset (-150 to 150MHz)			Sensitivity (≤ 70 dBm)		
		2402MHz	2442MHz	2408MHz	2402MHz	2442MHz	2408MHz	2402MHz	2442MHz	2408MHz
Ble_1M_prbs9	2#	0.45	0.81	0.66	-8.06	-6.68	-3.64	-82.5	-83.5	-84.5
Ble_1M_prbs9	4#	0.25	0.63	0.44	1.27	2.23	2.80	-84.0	-84.5	-86.0
Ble_1M_prbs9	6#	0.23	0.51	0.33	1.72	3.74	-2.14	-84.0	-84.0	-85.5
Ble_1M_prbs9	7#	0.05	0.29	0.02	3.21	2.99	-2.74	-82.0	-82.5	-83.5
Ble_1M_prbs9	8#	1.04	1.27	1.11	7.41	6.99	5.38	-83.5	-84.0	-85.0
	1. Test sensitivity: <ul style="list-style-type: none"> ■ Sent 100~1500 packets@PER\leq30.8% ■ packets type: BT_LE PRBS9 ■ packets length: 37 bytes 2. Max input level \geq -10dBm.									
Result	OK									

19. Design notes

1. Some power rails have to be externally connected, see section-11.
2. The BT RF signal has two routes to the antenna. The 1st route goes to the PCB trace antenna through L1, The 2nd route goes to pin-2 on the module through the R1 resistor then to the external antenna, the R1 resistor is not populated as default.

Using the external antenna gives better performance and a longer RF signal range.

Please put on a 0-ohm resistor or 10pF capacitor at the R1 location and remove L1 (see section-8, PCB placement top view). One SMA antenna socket is recommended in designing the carrier or host board for this antenna.

3. The WURX signal on pin-3 is input for Wake up Receiver.

The use of a wake-up receiver allows a system to be in sleep mode while waiting for incoming RF activities. In the SoC, the wake-up receiver is designed to decode an incoming RF paging or wake-up signal with very low power consumption. This dedicated low-power wake-up receiver continuously monitors the incoming RF signal for a predefined paging signal. This continuous Rx mode is based on an OOK radio, which has ultra-low power consumption. The wake-up receiver is intended for short-range and short-latency applications. The latency of the wake-up receiver is typically in the order of 20 ms to 1 s, depending on the length of the Rx ID code used to identify the target device.

In designing the carrier or host board, an SMA antenna socket is recommended going through a serial 10pF capacitor.

20. Evaluation board -EVB/ DVB

There is the Evaluation board (EVB or DVB) dedicated for the developmet of the GTI-ATM2022-X module, please contact us if you need it.

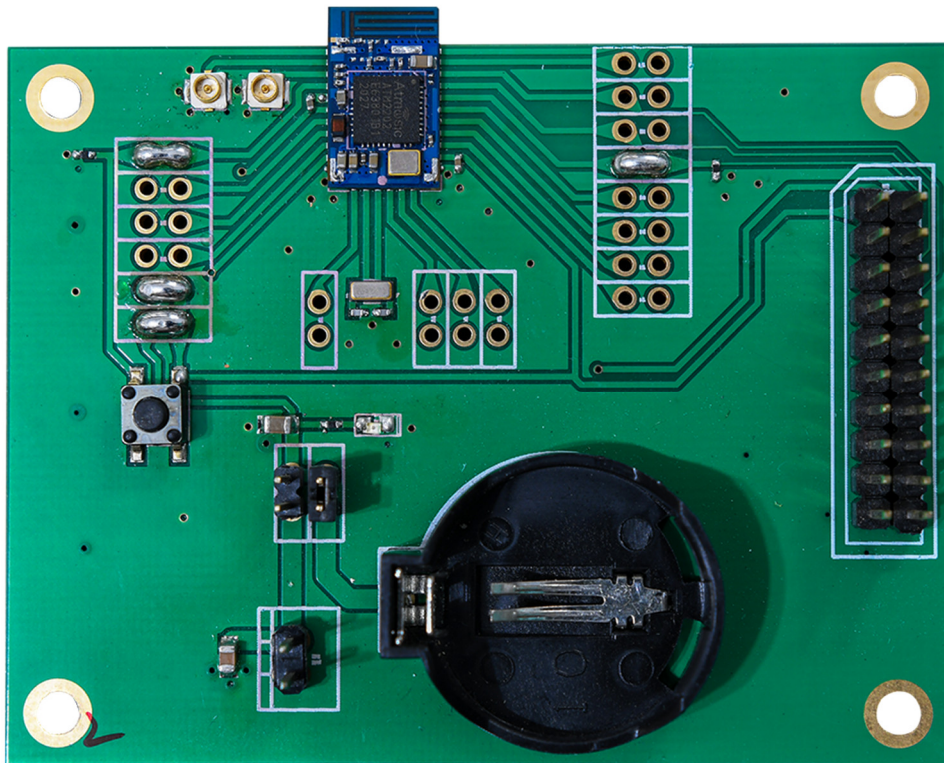

21. Recommended Reflow Profile

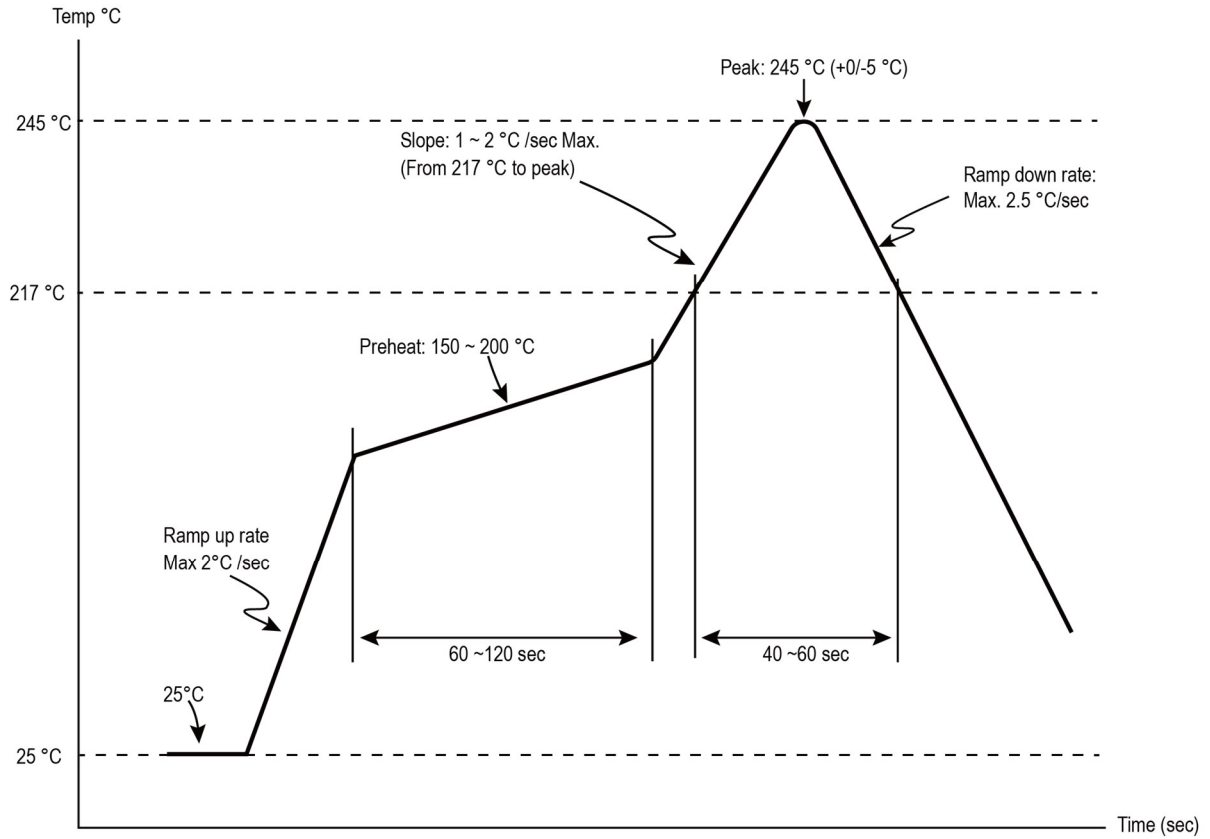

22. Package

ITEM	W	AD	BO	K1	KO	P	F	E	DO	D1	P0	P2	T
DIM	24.0	$9.90^{+0.30/-0.30}$	$14.60^{+0.10/-0.10}$	---	$2.20^{+0.10/-0.10}$	$16.0^{+0.10/-0.10}$	$14.20^{+0.10/-0.10}$	$1.75^{+0.10/-0.10}$	$\phi 1.5^{+0.10/-0.05}$	$\phi 1.5^{+0.10/-0.05}$	$4.0^{+0.10/-0.10}$	$2.0^{+0.10/-0.10}$	$0.35^{+0.05/-0.05}$

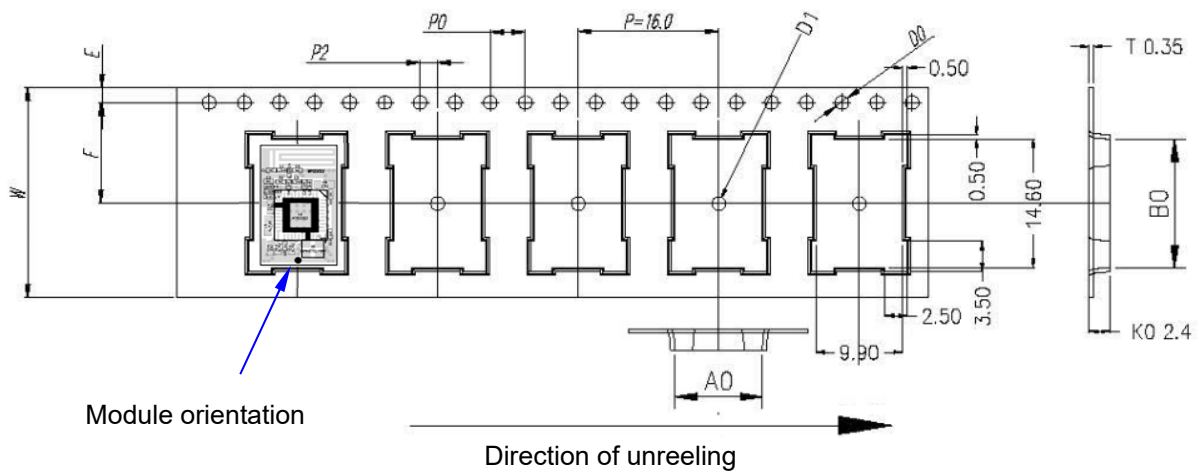

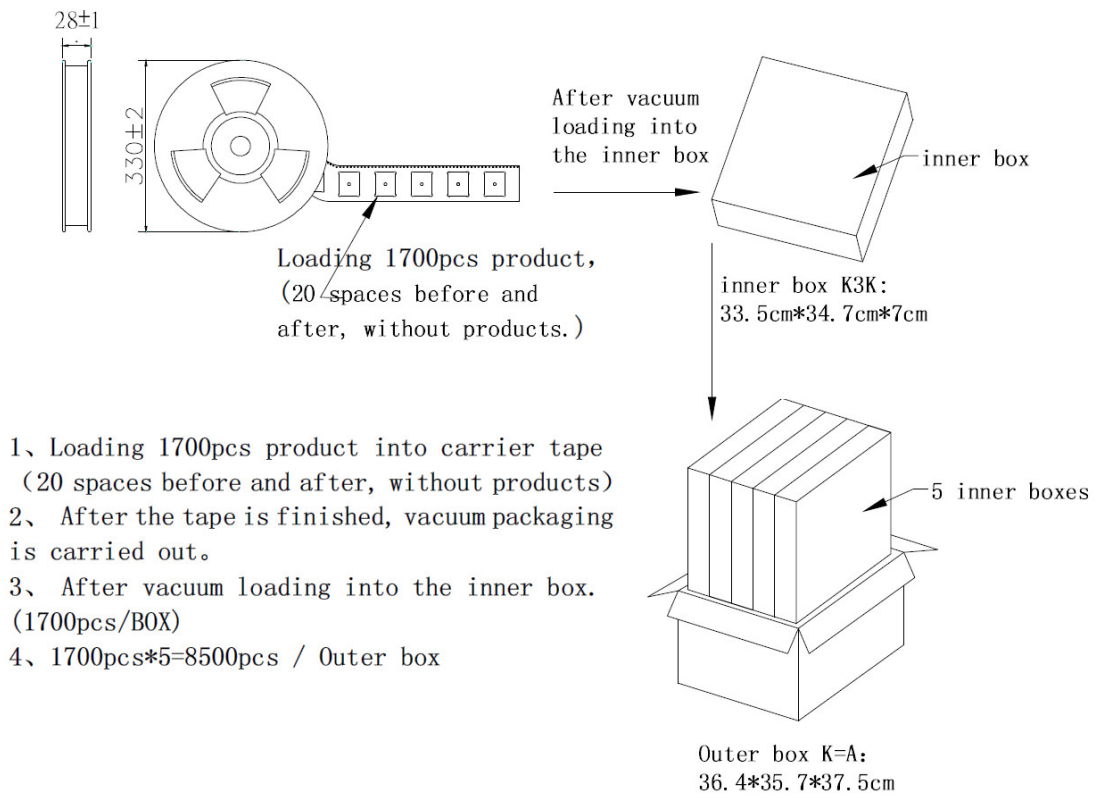

ESD CAUTION

The GTI-ATM2022-X is ESD (electrostatic discharge) sensitive device and may be damaged with ESD or spike voltage. Although GTI-ATM2022-X is with built-in ESD protection circuitry, please handle with care to avoid the permanent malfunction or the performance degradation.

FCC

Federal Communication Commission Interference Statement

This equipment has been tested and found to comply with the limits for a Class B digital device, pursuant to Part 15 of the FCC Rules. These limits are designed to provide reasonable protection against harmful interference in a residential installation. This equipment generates, uses and can radiate radio frequency energy and, if not installed and used in accordance with the instructions, may cause harmful interference to radio communications. However, there is no guarantee that interference will not occur in a particular installation. If this equipment does cause harmful interference to radio or television reception, which can be determined by turning the equipment off and on, the user is encouraged to try to correct the interference by one of the following measures:

- Reorient or relocate the receiving antenna.
- Increase the separation between the equipment and receiver.

connected.

- Consult the dealer or an experienced radio/TV technician for help.
- Connect the equipment into an outlet on a circuit different from that to which the receiver is

FCC Caution:

Any changes or modifications not expressly approved by the party responsible for compliance could void the user's authority to operate this equipment.

This device complies with Part 15 of the FCC Rules. Operation is subject to the following two conditions: (1) This device may not cause harmful interference, and (2) this device must accept any interference received, including interference that may cause undesired operation.

CFR 47 FCC PART 15 SUBPART C has been investigated. It is applicable to the modular transmitter

2.3 Specific operational use conditions

This module is stand-alone modular. If the end product will involve the Multiple simultaneously transmitting condition or different operational conditions for a stand-alone modular transmitter in a host, host manufacturer have to consult with module manufacturer for the installation method in end system.

2.4 Limited module procedures

This module is single modular with shielding.

2.5 Trace antenna designs

Not applicable

2.6 RF exposure considerations

This equipment complies with FCC radiation exposure limits set forth for an uncontrolled environment. This equipment should be installed and operated with minimum distance 20cm between the radiator & your body.

2.7 Antennas

The following antenna will be used with the Atmosic BLE module and integrated into Globalscale Technologies INC products, The Atmosic BLE module is not designed for multiple antenna applications and should not be used to transmit simultaneously with any other transmitter. The Atmosic BLE module is only certified to use the PCB antenna. Antenna Description: PCB antenna, 1.5dBi(Max.)

2.8 Label and compliance information

The final end product must be labeled in a visible area with the following "Contains FCC ID: YCJGTIBLEATM-2022.

2.9 Information on test modes and additional testing requirements

Host manufacturer which install this modular with limit modular approval should perform the test of radiated emission and spurious emission according to FCC part 15C:15.247 and 15.209 requirement, only if the test result comply with FCC part 15.247 and 15.209 requirement, then the host can be sold legally.

2.10 Additional testing, Part 15 Subpart B disclaimer

Host manufacturer is responsible for compliance of the host system with module installed with all other applicable requirements for the system such as Part 15 B.

23. Contacts

Sales@globalscaletechnologies.com

Globalscale Technologies, Inc.
1200 N. Van Buren Street
Anaheim, CA 92807
U.S.A.

Office (714) 632 9239
Fax (714) 632 7550