

APPLICATION CERTIFICATION FCC Part 15C  
On Behalf of  
Globalscale Technologies INC

GuruPlug

Model No.: 003-GPXXXXXXX (XXXXXXX is any number or English character)

FCC ID: YCJ003GP

Prepared for : Globalscale Technologies INC  
Address : 5F, No.2 Building, Minxing industrial Park, Minkang  
Road, Minzhi Street, Baoan District, Shenzhen,  
Guangdong, China

Prepared by : ACCURATE TECHNOLOGY CO. LTD  
Address : F1, Bldg. A, Changyuan New Material Port, Keyuan Rd.  
Science & Industry Park, Nanshan, Shenzhen, Guangdong  
P.R. China

Tel: (0755) 26503290  
Fax: (0755) 26503396

Report Number : ATE20100630  
Date of Test : April 15-17, 2010  
Date of Report : April 20, 2010

## TABLE OF CONTENTS

Description	Page
Test Report Certification	
<b>1. GENERAL INFORMATION .....</b>	<b>5</b>
1.1. Description of Device (EUT).....	5
1.2. Description of Test Facility .....	6
1.3. Measurement Uncertainty .....	6
<b>2. MEASURING DEVICE AND TEST EQUIPMENT .....</b>	<b>7</b>
<b>3. OPERATION OF EUT DURING TESTING .....</b>	<b>8</b>
3.1. Operating Mode .....	8
3.2. Configuration and peripherals .....	8
<b>4. TEST PROCEDURES AND RESULTS .....</b>	<b>9</b>
<b>5. 6DB BANDWIDTH MEASUREMENT .....</b>	<b>10</b>
5.1. Block Diagram of Test Setup.....	10
5.2. The Requirement For Section 15.247(a)(1).....	10
5.3. EUT Configuration on Measurement .....	10
5.4. Operating Condition of EUT .....	10
5.5. Test Procedure .....	11
5.6. Test Result .....	11
<b>6. MAXIMUM PEAK OUTPUT POWER .....</b>	<b>18</b>
6.1. Block Diagram of Test Setup.....	18
6.2. The Requirement For Section 15.247(b)(3).....	18
6.3. EUT Configuration on Measurement .....	18
6.4. Operating Condition of EUT .....	18
6.5. Test Procedure .....	19
6.6. Test Result .....	19
<b>7. POWER SPECTRAL DENSITY MEASUREMENT.....</b>	<b>26</b>
7.1. Block Diagram of Test Setup.....	26
7.2. The Requirement For Section 15.247(e).....	26
7.3. EUT Configuration on Measurement .....	26
7.4. Operating Condition of EUT .....	26
7.5. Test Procedure .....	27
7.6. Test Result .....	27
<b>8. BAND EDGE COMPLIANCE TEST (WI-FI).....</b>	<b>34</b>
8.1. Block Diagram of Test Setup.....	34
8.2. The Requirement For Section 15.247(d) .....	34
8.3. EUT Configuration on Measurement .....	34
8.4. Operating Condition of EUT .....	35
8.5. Test Procedure .....	35
8.6. Test Result .....	36
<b>9. RADIATED SPURIOUS EMISSION TEST .....</b>	<b>41</b>
9.1. Block Diagram of Test Setup.....	41
9.2. The Limit For Section 15.247(d) .....	42
9.3. Restricted bands of operation .....	42
9.4. Configuration of EUT on Measurement .....	43
9.5. Operating Condition of EUT .....	43

- 9.6. Test Procedure .....43
- 9.7. The Field Strength of Radiation Emission Measurement Results .....44
- 10. CONDUCTED SPURIOUS EMISSION COMPLIANCE TEST ..... 86**
  - 10.1. Block Diagram of Test Setup.....86
  - 10.2. The Requirement For Section 15.247(d) .....86
  - 10.3. EUT Configuration on Measurement .....86
  - 10.4. Operating Condition of EUT .....87
  - 10.5. Test Procedure .....87
  - 10.6. Test Result .....87
- 11. AC POWER LINE CONDUCTED EMISSION FOR FCC PART 15 SECTION 15.207(A) 106**
  - 11.1. Block Diagram of Test Setup.....106
  - 11.2. The Emission Limit .....106
  - 11.3. Configuration of EUT on Measurement .....107
  - 11.4. Operating Condition of EUT .....107
  - 11.5. Test Procedure .....107
  - 11.6. Power Line Conducted Emission Measurement Results .....108
- 12. ANTENNA REQUIREMENT..... 114**
  - 12.1. The Requirement .....114
  - 12.2. Antenna Construction .....114

# Test Report Certification

Applicant : Globalscale Technologies INC

Manufacturer : Globalscale Technologies INC

EUT Description : GuruPlug

(A) MODEL NO.: 003-GPXXXXXXX (XXXXXX is any number or English character)

(B) SERIAL NO.: N/A

(C) POWER SUPPLY: AC 100-240V, 50-60Hz

Measurement Procedure Used:

**FCC Rules and Regulations Part 15 Subpart C Section 15.247  
ANSI C63.4: 2003**

The device described above is tested by ACCURATE TECHNOLOGY CO. LTD to determine the maximum emission levels emanating from the device. The maximum emission levels are compared to the FCC Part 15 Subpart C Section 15.247 limits. The measurement results are contained in this test report and ACCURATE TECHNOLOGY CO. LTD is assumed full responsibility for the accuracy and completeness of these measurements. Also, this report shows that the Equipment Under Test (EUT) is to be technically compliant with the FCC requirements.

This report applies to above tested sample only. This report shall not be reproduced in part without written approval of ACCURATE TECHNOLOGY CO. LTD.

Date of Test : April 15-17, 2010

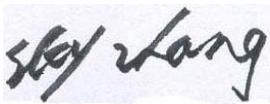
Prepared by :   
(Engineer)

Approved & Authorized Signer :   
(Manager)

# 1. GENERAL INFORMATION

## 1.1. Description of Device (EUT)

EUT	:	GuruPlug
Model Number	:	003-GPXXXXXX (XXXXXX is any number or English character)
		(Note: only model 003-GP11A101 is tested.)
Frequency Band	:	2412-2462MHz
Number of Channels	:	11
Antenna Gain	:	0dBi
Power Supply	:	AC 100-240V, 50-60Hz
Data Rate	:	IEEE 802.11b: 11/5.5/2/1Mbps IEEE 802.11g: 54/48/36/24/18/12/9/6Mbps
Applicant	:	Globalscale Technologies INC
Address	:	5F, No.2 Building, Minxing industrial Park, Minkang Road, Minzhi Street, Baoan District, Shenzhen, Guangdong, China
Manufacturer	:	Globalscale Technologies INC
Address	:	5F, No.2 Building, Minxing industrial Park, Minkang Road, Minzhi Street, Baoan District, Shenzhen, Guangdong, China
Date of sample received	:	April 2, 2010
Date of Test	:	April 15-17, 2010

## 1.2. Description of Test Facility

EMC Lab : Accredited by TUV Rheinland Shenzhen

Listed by FCC  
The Registration Number is 752051

Listed by Industry Canada  
The Registration Number is 5077A-2

Accredited by China National Accreditation Committee  
for Laboratories  
The Certificate Registration Number is L3193

Name of Firm : ACCURATE TECHNOLOGY CO. LTD  
Site Location : F1, Bldg. A, Changyuan New Material Port, Keyuan Rd.  
Science & Industry Park, Nanshan, Shenzhen, Guangdong  
P.R. China

## 1.3. Measurement Uncertainty

Conducted Emission Expanded Uncertainty = 2.23dB, k=2

Radiated emission expanded uncertainty = 3.08dB, k=2  
(9kHz-30MHz)

Radiated emission expanded uncertainty = 4.42dB, k=2  
(30MHz-1000MHz)

Radiated emission expanded uncertainty = 4.06dB, k=2  
(Above 1GHz)

## 2. MEASURING DEVICE AND TEST EQUIPMENT

**Table 1: List of Test and Measurement Equipment**

Kind of equipment	Manufacturer	Type	S/N	Calibrated until
EMI Test Receiver	Rohde&Schwarz	ESCS30	100307	Jan. 9, 2011
EMI Test Receiver	Rohde&Schwarz	ESPI3	101526/003	Jan. 9, 2011
Spectrum Analyzer	Agilent	E7405A	MY45115511	Jan. 9, 2011
Pre-Amplifier	Rohde&Schwarz	CBLU118354 0-01	3791	Jan. 9, 2011
Loop Antenna	Schwarzbeck	FMZB1516	1516131	Jan. 9, 2011
Bilog Antenna	Schwarzbeck	VULB9163	9163-323	Jan. 9, 2011
Horn Antenna	Schwarzbeck	BBHA9120D	9120D-655	Jan. 9, 2011
Horn Antenna	Schwarzbeck	BBHA9170	9170-359	Jan. 9, 2011
LISN	Rohde&Schwarz	ESH3-Z5	100305	Jan. 9, 2011
LISN	Schwarzbeck	NSLK8126	8126431	Jan. 9, 2011

### 3. OPERATION OF EUT DURING TESTING

#### 3.1. Operating Mode

The mode is used: **802.11b Transmitting mode**

Low Channel: 2412MHz

Middle Channel: 2437MHz

High Channel: 2462MHz

**802.11g Transmitting mode**

Low Channel: 2412MHz

Middle Channel: 2437MHz

High Channel: 2462MHz

#### 3.2. Configuration and peripherals

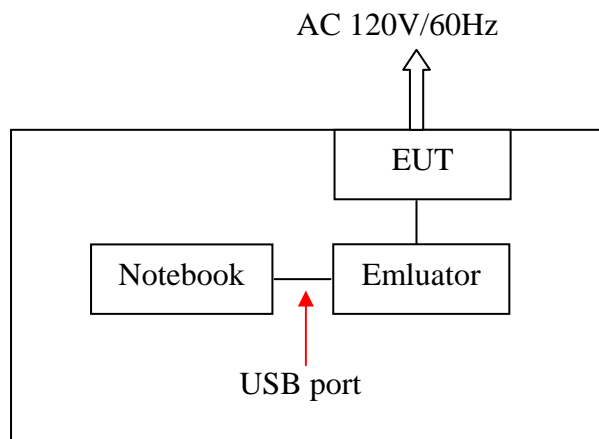

Figure 1 Setup: Transmitting mode



#### 4. TEST PROCEDURES AND RESULTS

<b>FCC Rules</b>	<b>Description of Test</b>	<b>Result</b>
Section 15.247(a)(2)	6dB Bandwidth Test	Compliant
Section 15.247(e)	Power Spectral Density Test	Compliant
Section 15.247(b)(3)	Maximum Peak Output Power Test	Compliant
Section 15.247(d)	Band Edge Compliance Test	Compliant
Section 15.247(d) Section 15.209	Radiated Spurious Emission Test	Compliant
Section 15.247(d)	Conducted Spurious Emission Test	Compliant
Section 15.207	AC Power Line Conducted Emission Test	Compliant
Section 15.203	Antenna Requirement	Compliant

## 5. 6DB BANDWIDTH MEASUREMENT

### 5.1. Block Diagram of Test Setup



(EUT: GuruPlug)

### 5.2. The Requirement For Section 15.247(a)(1)

Section 15.247(a)(2): Systems using digital modulation techniques may operate in the 902-928MHz, 2400-2483.5MHz, and 5725-5850MHz bands. The minimum 6 dB bandwidth shall be at least 500 kHz.

### 5.3. EUT Configuration on Measurement

The following equipment are installed on the emission measurement to meet the commission requirements and operating regulations in a manner which tends to maximize its emission characteristics in normal application.

#### 5.3.1. GuruPlug (EUT)

Model Number : 003-GP11A101  
 Serial Number : N/A  
 Manufacturer : Globalscale Technologies INC

### 5.4. Operating Condition of EUT

5.4.1. Setup the EUT and simulator as shown as Section 5.1.

5.4.2. Turn on the power of all equipment.

5.4.3. Let the EUT work in TX modes measure it. The transmit frequency are 2412-2462MHz. We select 2412MHz, 2437MHz, 2462MHz TX frequency to transmit.

## 5.5. Test Procedure

5.5.1. The transmitter output was connected to the spectrum analyzer through a low loss cable.

5.5.2. Set RBW of spectrum analyzer to 100kHz and VBW to 300kHz.

5.5.3. The 6dB bandwidth is defined as the total spectrum the power of which is higher than peak power minus 6dB.

## 5.6. Test Result

**PASS.**

Date of Test:	<u>April 16, 2010</u>	Temperature:	<u>25°C</u>
EUT:	<u>GuruPlug</u>	Humidity:	<u>50%</u>
Model No.:	<u>003-GP11A101</u>	Power Supply:	<u>AC 120V/60HZ</u>
Test Mode:	<u>TX</u>	Test Engineer:	<u>Joe</u>

The test was performed with 802.11b, the data was shown the worst case 802.11b 1Mbps.

Channel	Frequency (MHz)	6dB Bandwidth (MHz)	Limit (MHz)
Low	2412	12.040	> 0.5MHz
Middle	2437	12.040	> 0.5MHz
High	2462	12.040	> 0.5MHz

The test was performed with 802.11g, the data was shown the worst case 802.11g 6Mbps.

Channel	Frequency (MHz)	6dB Bandwidth (MHz)	Limit (MHz)
Low	2412	16.360	> 0.5MHz
Middle	2437	16.400	> 0.5MHz
High	2462	46.400	> 0.5MHz

The spectrum analyzer plots are attached as below.

802.11b Channel Low 2412MHz



\*RBW 100 kHz Delta 2 [T1 ]  
VBW 300 kHz -0.31 dB  
SWT 2.5 ms 12.040000000 MHz

Ref 30 dBm

Att 60 dB

1 PK  
MAXH

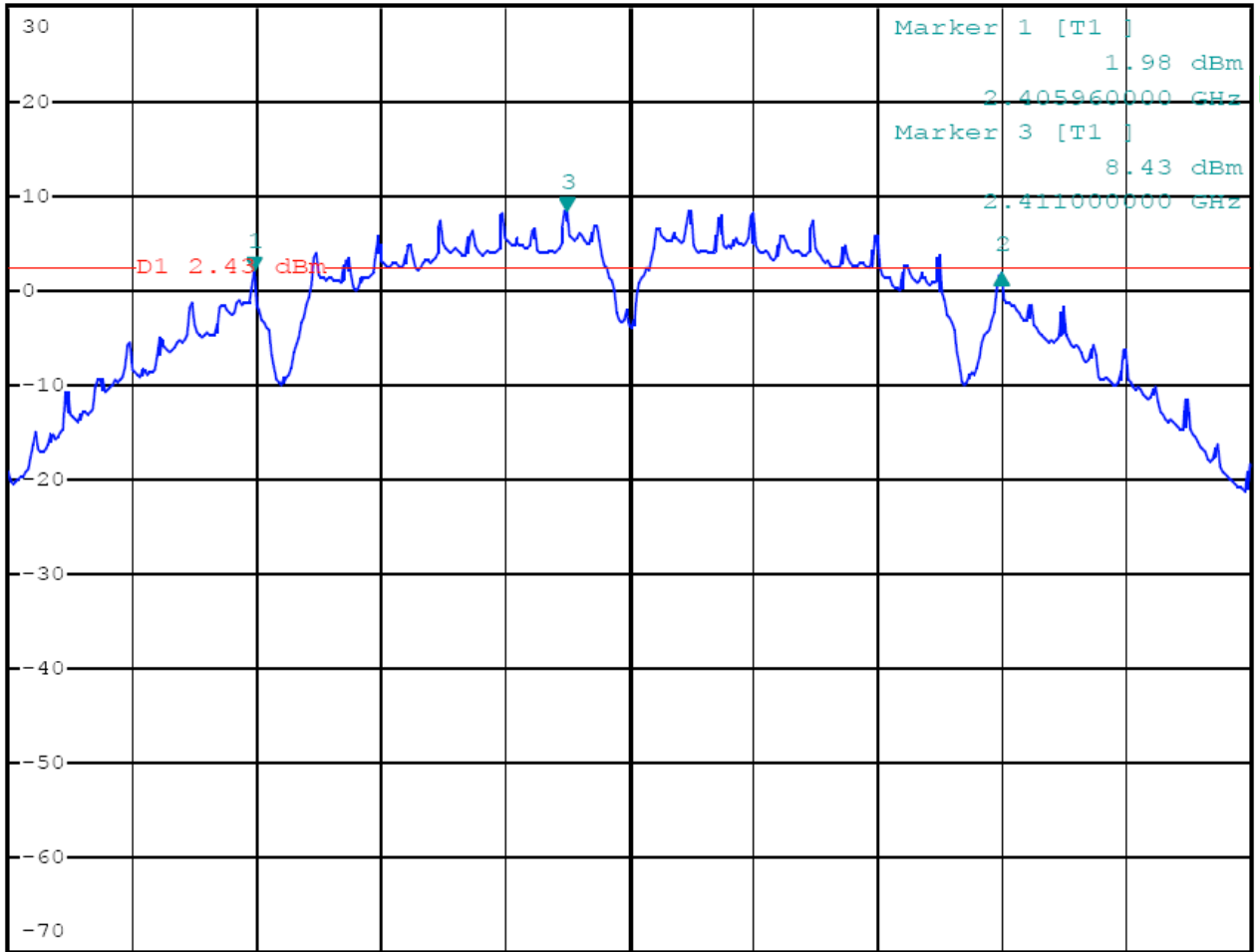

Center 2.412 GHz

2 MHz/

Span 20 MHz

802.11b Channel Middle 2437MHz



\*RBW 100 kHz Delta 2 [T1 ]  
VBW 300 kHz -0.28 dB  
SWT 2.5 ms 12.040000000 MHz

Ref 30 dBm

Att 60 dB

1 PK  
MAXH

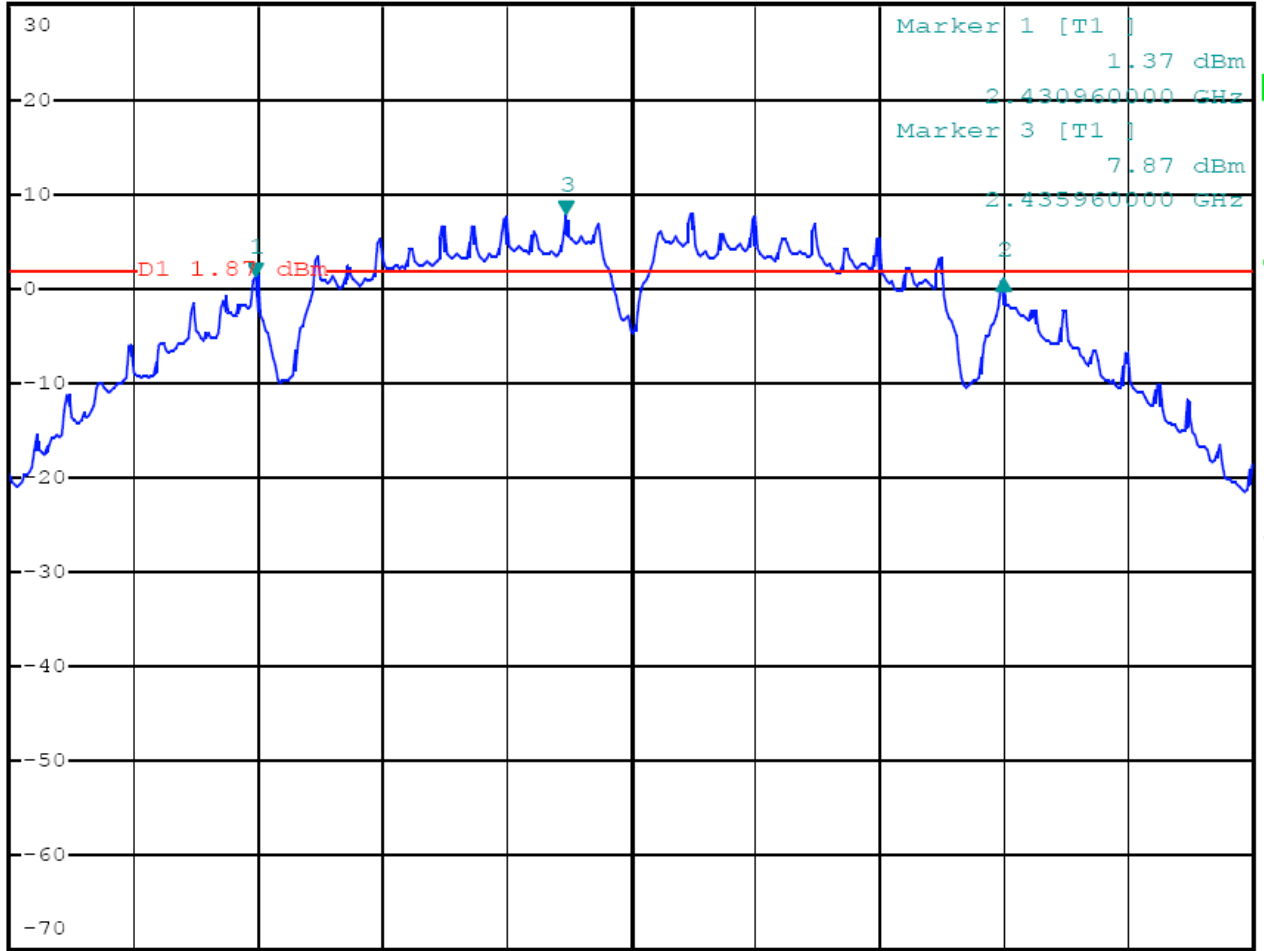

Center 2.437 GHz

2 MHz/

Span 20 MHz

### 802.11b Channel High 2462MHz



\*RBW 100 kHz Delta 2 [T1 ]  
VBW 300 kHz -0.09 dB  
SWT 2.5 ms 12.040000000 MHz

Ref 30 dBm

Att 60 dB

1 PK  
MAXH

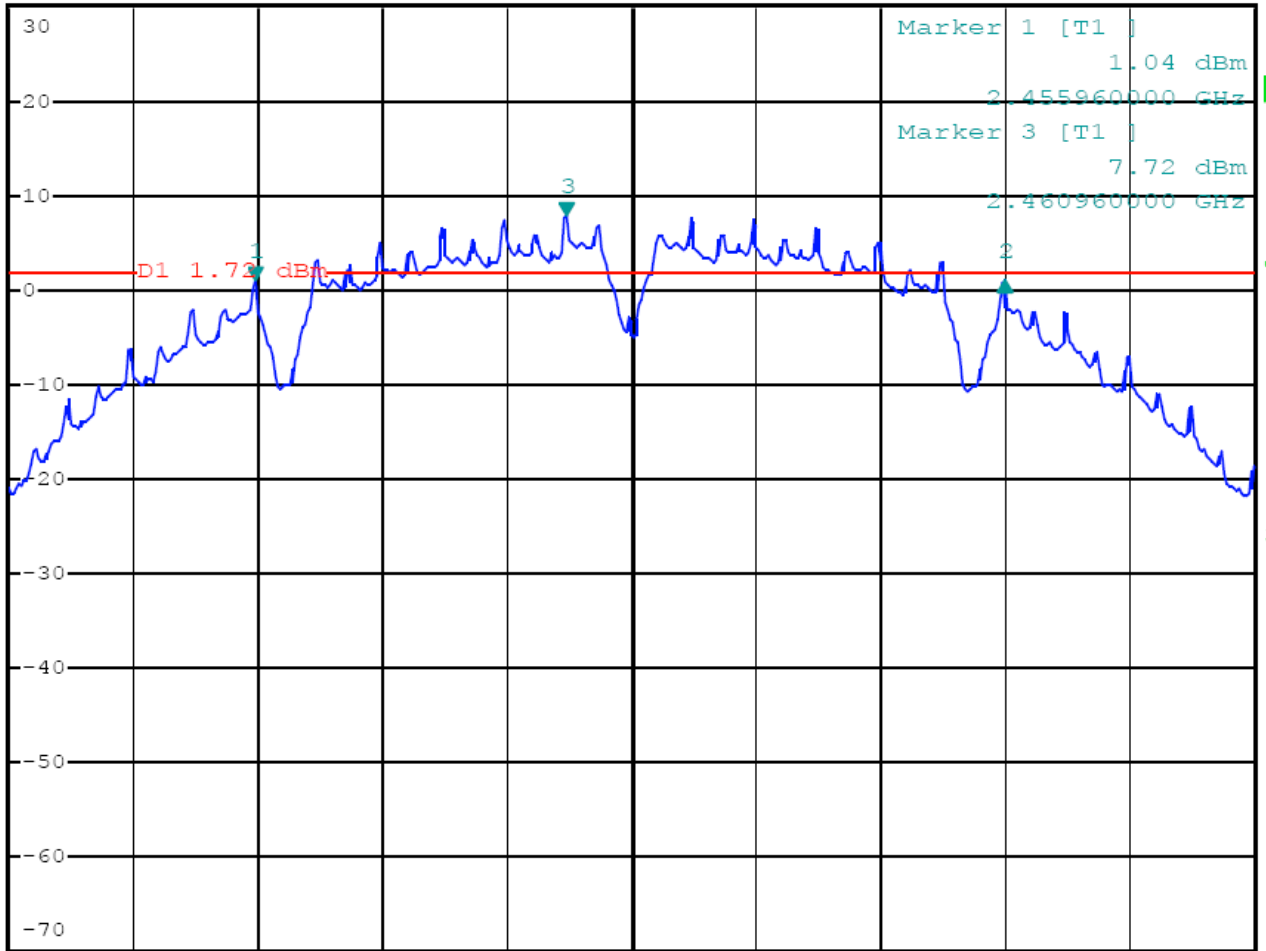

Center 2.462 GHz

2 MHz/

Span 20 MHz

802.11g Channel Low 2412MHz



\*RBW 100 kHz Delta 2 [T1 ]  
VBW 300 kHz -0.68 dB  
SWT 2.5 ms 16.360000000 MHz

Ref 30 dBm

Att 60 dB

1 PK  
MAXH

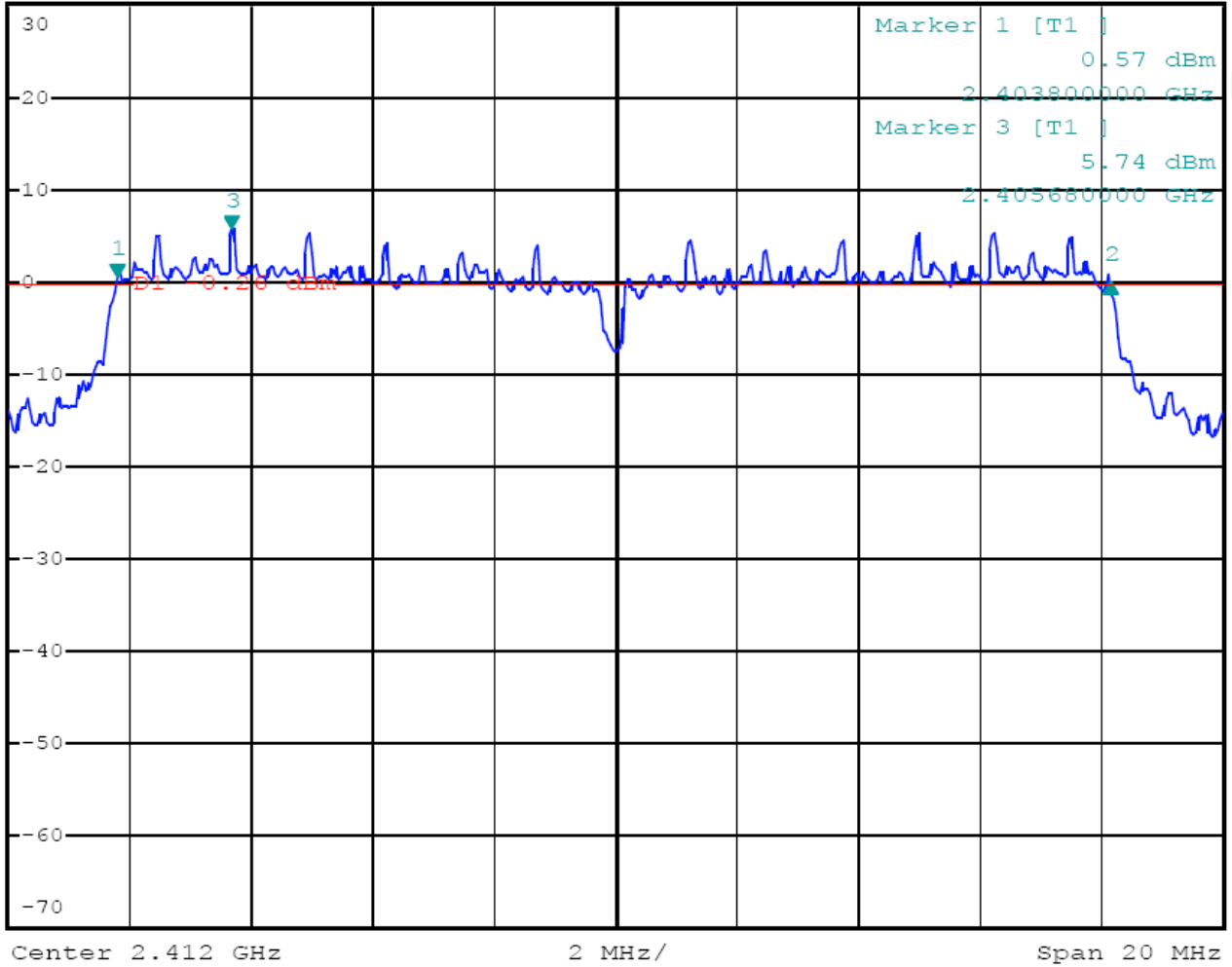

### 802.11g Channel Middle 2437MHz



\*RBW 100 kHz Delta 2 [T1 ]  
VBW 300 kHz -0.84 dB  
SWT 2.5 ms 16.400000000 MHz

Ref 30 dBm

Att 60 dB

1 PK  
MAXH

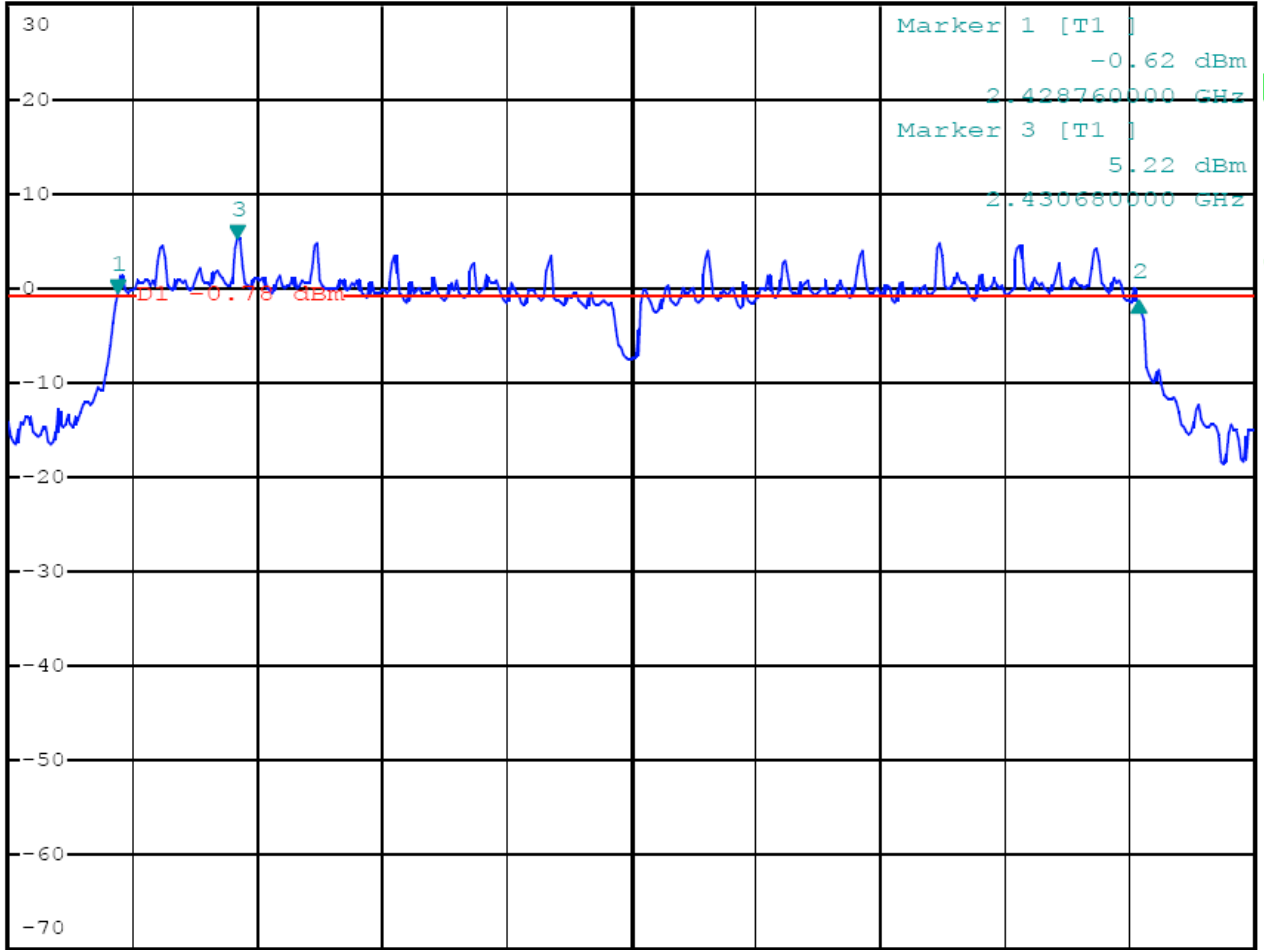

Center 2.437 GHz

2 MHz/

Span 20 MHz



### 802.11g Channel High 2462MHz



\*RBW 100 kHz Delta 2 [T1 ]  
VBW 300 kHz -0.15 dB  
SWT 2.5 ms 16.400000000 MHz

Ref 30 dBm

Att 60 dB

1 PK  
MAXH

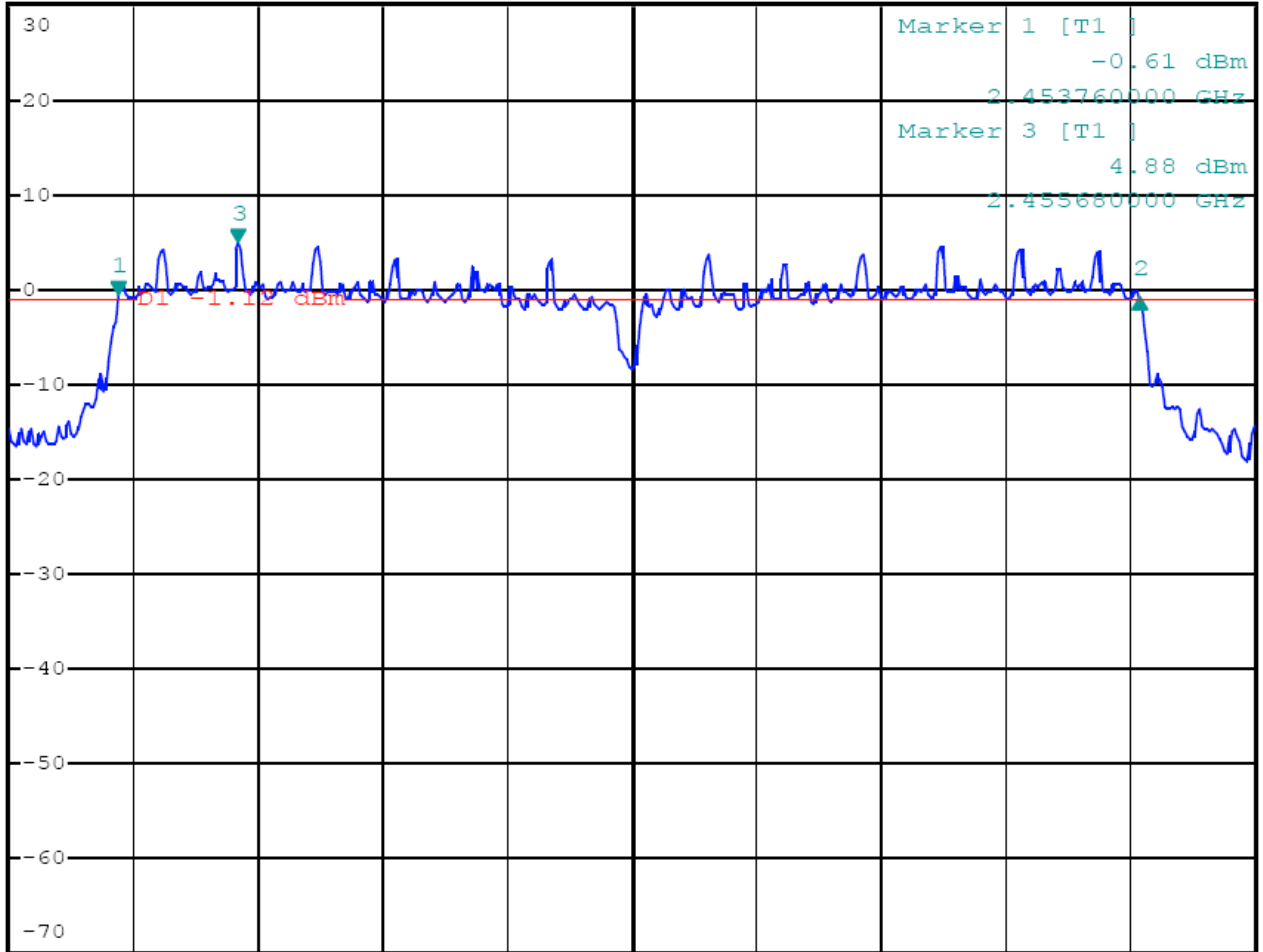

Center 2.462 GHz

2 MHz/

Span 20 MHz

## 6. MAXIMUM PEAK OUTPUT POWER

### 6.1. Block Diagram of Test Setup



(EUT: GuruPlug)

### 6.2. The Requirement For Section 15.247(b)(3)

Section 15.247(b)(3): For systems using digital modulation in the 902-928MHz, 2400-2483.5MHz, and 5725-5850MHz bands: 1 Watt.

### 6.3. EUT Configuration on Measurement

The following equipment are installed on the emission Measurement to meet the commission requirements and operating regulations in a manner which tends to maximize its emission characteristics in normal application.

#### 6.3.1. GuruPlug (EUT)

Model Number : 003-GP11A101  
 Serial Number : N/A  
 Manufacturer : Globalscale Technologies INC

### 6.4. Operating Condition of EUT

6.4.1. Setup the EUT and simulator as shown as Section 6.1.

6.4.2. Turn on the power of all equipment.

6.4.3. Let the EUT work in TX modes measure it. The transmit frequency are 2412-2462MHz. We select 2412MHz, 2437MHz, 2462MHz TX frequency to transmit.

## 6.5. Test Procedure

6.5.1. The transmitter output was connected to the spectrum analyzer through a low loss cable.

6.5.2. Set RBW of spectrum analyzer to 1MHz and VBW to 3MHz.

6.5.3. Measurement the maximum peak output power.

## 6.6. Test Result

**PASS.**

Date of Test:	<u>April 16, 2010</u>	Temperature:	<u>25°C</u>
EUT:	<u>GuruPlug</u>	Humidity:	<u>50%</u>
Model No.:	<u>003-GP11A101</u>	Power Supply:	<u>AC 120V/60HZ</u>
Test Mode:	<u>TX</u>	Test Engineer:	<u>Joe</u>

The test was performed with 802.11b, the data was shown the worst case 802.11b 1Mbps.

Channel	Frequency (MHz)	Peak Output Power (dBm)	Peak Output Power (mW)	Limits dBm / W
Low	2412	20.83	121.1	30 dBm / 1 W
Middle	2437	20.36	108.6	30 dBm / 1 W
High	2462	20.19	104.5	30 dBm / 1 W

The test was performed with 802.11g, the data was shown the worst case 802.11g 6Mbps.

Channel	Frequency (MHz)	Peak Output Power (dBm)	Peak Output Power (mW)	Limits dBm / W
Low	2412	23.98	250.0	30 dBm / 1 W
Middle	2437	23.58	228.0	30 dBm / 1 W
High	2462	23.31	214.3	30 dBm / 1 W

The spectrum analyzer plots are attached as below.

### 802.11b Channel Low 2412MHz



\*RBW 1 MHz  
VBW 3 MHz  
SWT 2.5 ms

Ref 30 dBm

Att 50 dB

1 PK  
MAXH

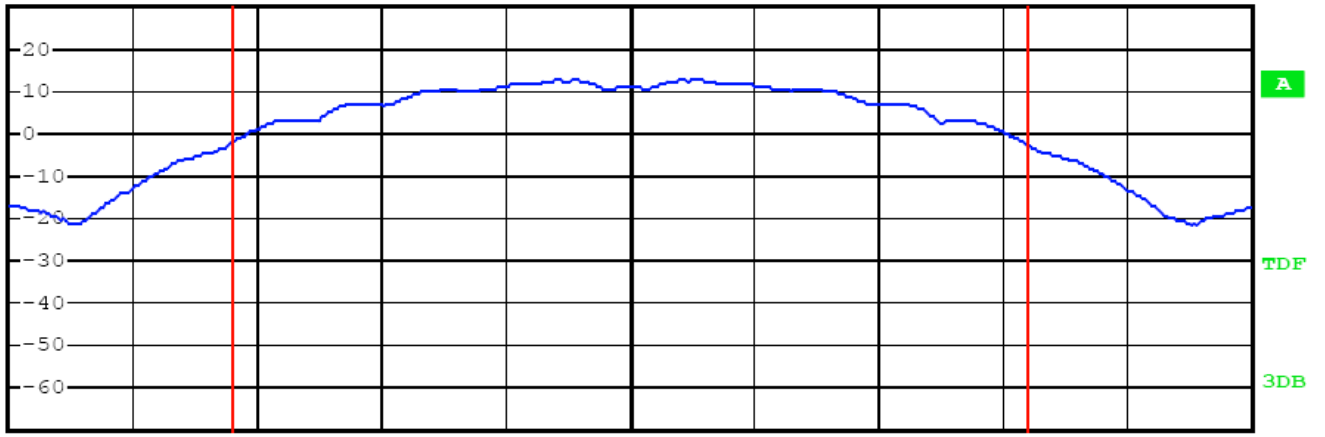

Center 2.412 GHz

2.5 MHz/

Span 25 MHz

**Tx Channel**

Bandwidth

16 MHz

Power

20.83 dBm

### 802.11b Channel Middle 2437MHz



\*RBW 1 MHz  
VBW 3 MHz  
SWT 2.5 ms

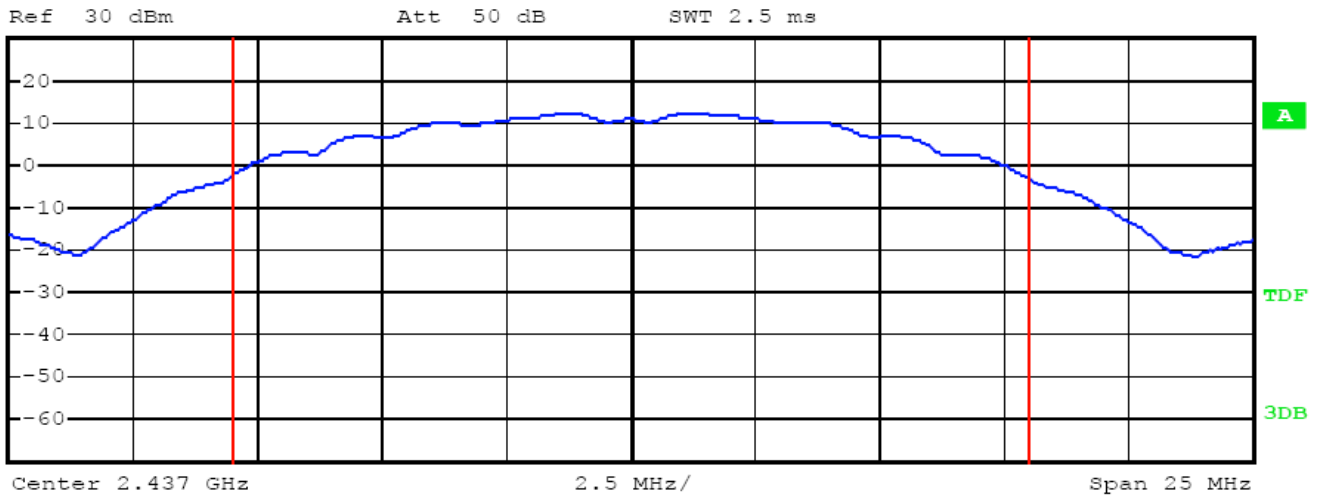

**Tx Channel**  
Bandwidth      16 MHz      Power      20.36 dBm

### 802.11b Channel High 2462MHz



\* RBW 1 MHz  
VBW 3 MHz  
SWT 2.5 ms

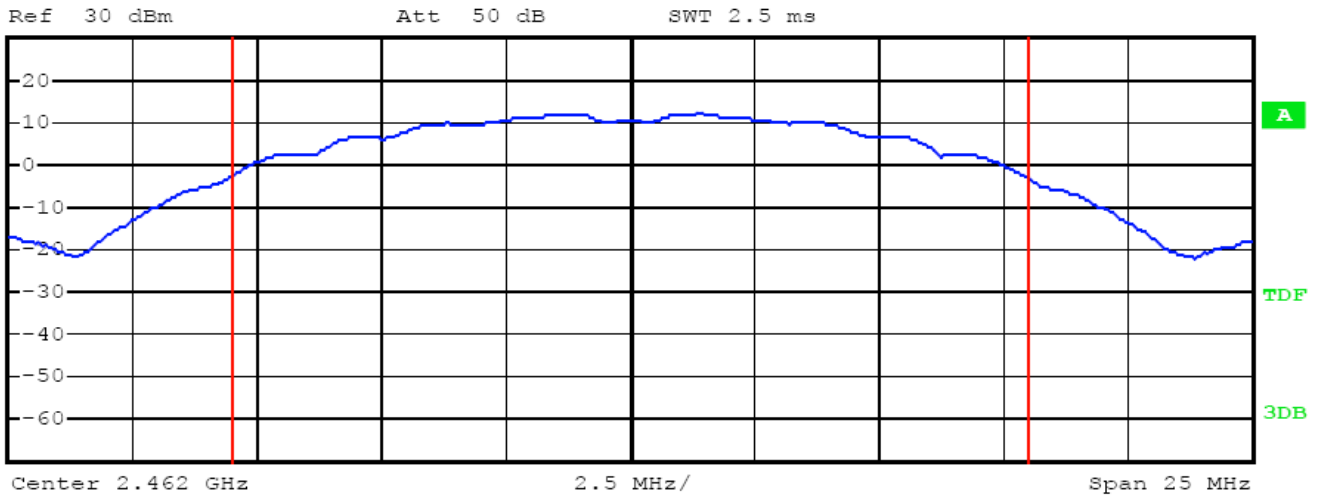

**Tx Channel**  
Bandwidth 16 MHz Power 20.19 dBm

### 802.11g Channel Low 2412MHz



\* RBW 1 MHz  
VBW 3 MHz  
SWT 2.5 ms

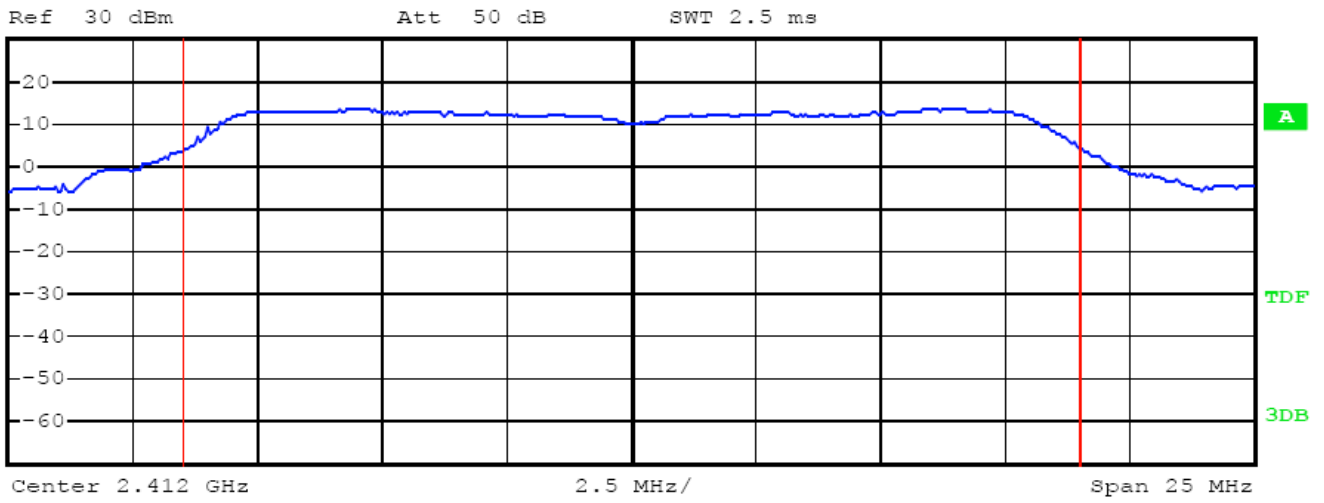

**Tx Channel**

Bandwidth

18 MHz

Power

23.98 dBm

### 802.11g Channel Middle 2437MHz



\* RBW 1 MHz  
VBW 3 MHz  
SWT 2.5 ms

Ref 30 dBm

Att 50 dB

1 PK  
MAXH

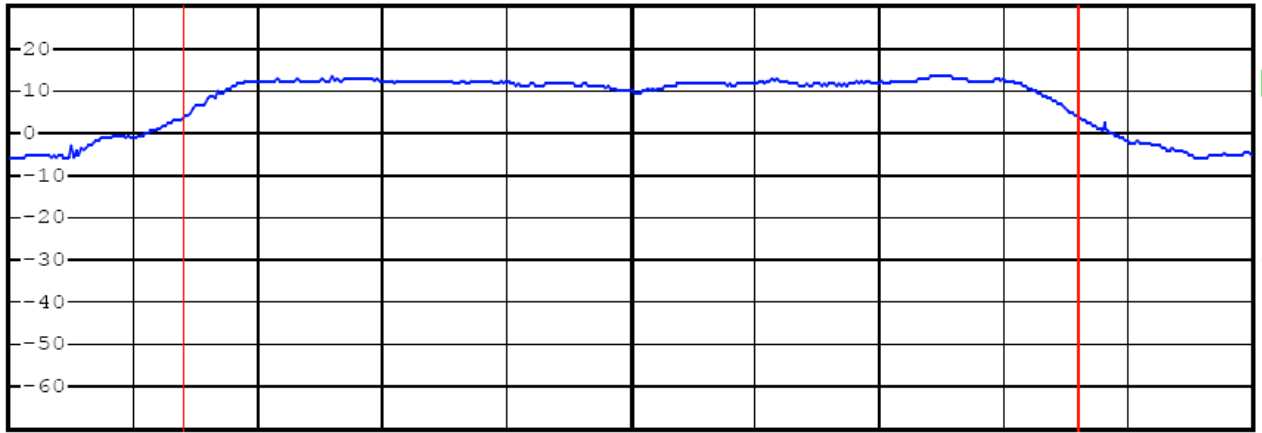

Center 2.437 GHz

2.5 MHz/

Span 25 MHz

**Tx Channel**

Bandwidth

18 MHz

Power

23.58 dBm



### 802.11g Channel High 2462MHz



\* RBW 1 MHz  
VBW 3 MHz  
SWT 2.5 ms

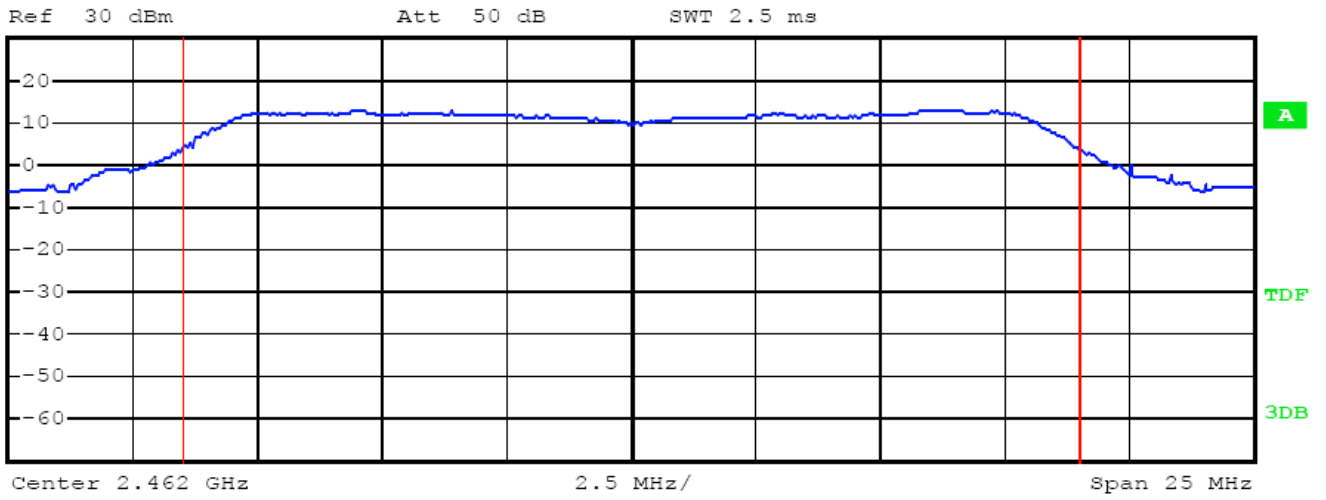

#### Tx Channel

Bandwidth                      18 MHz                      Power                      23.31 dBm

## 7. POWER SPECTRAL DENSITY MEASUREMENT

### 7.1. Block Diagram of Test Setup



(EUT: GuruPlug)

### 7.2. The Requirement For Section 15.247(e)

Section 15.247(e): For digitally modulated systems, the power spectral density conducted from the intentional radiator to the antenna shall not be greater than 8 dBm in any 3 kHz band during any time interval of continuous transmission.

### 7.3. EUT Configuration on Measurement

The following equipment are installed on the emission Measurement to meet the commission requirements and operating regulations in a manner which tends to maximize its emission characteristics in normal application.

#### 7.3.1. GuruPlug (EUT)

Model Number : 003-GP11A101  
 Serial Number : N/A  
 Manufacturer : Globalscale Technologies INC

### 7.4. Operating Condition of EUT

7.4.1. Setup the EUT and simulator as shown as Section 7.1.

7.4.2. Turn on the power of all equipment.

7.4.3. Let the EUT work in TX modes measure it. The transmit frequency are 2412-2462MHz. We select 2412MHz, 2437MHz, 2462MHz TX frequency to transmit.

## 7.5. Test Procedure

7.5.1. The transmitter output was connected to the spectrum analyzer through a low loss cable.

7.5.2. Set RBW of spectrum analyzer to 3kHz and VBW to 10kHz, sweep time = Span/3kHz.

7.5.3. Measurement the maximum power spectral density.

## 7.6. Test Result

**PASS.**

Date of Test:	<u>April 16, 2010</u>	Temperature:	<u>25°C</u>
EUT:	<u>GuruPlug</u>	Humidity:	<u>50%</u>
Model No.:	<u>003-GP11A101</u>	Power Supply:	<u>AC 120V/60HZ</u>
Test Mode:	<u>TX</u>	Test Engineer:	<u>Joe</u>

The test was performed with 802.11b, the data was shown the worst case 802.11b 1Mbps.			
Channel	Frequency (MHz)	Power Spectral Density (dBm)	Limits (dBm)
Low	2412	6.35	8 dBm
Middle	2437	4.42	8 dBm
High	2462	3.67	8 dBm

The test was performed with 802.11g, the data was shown the worst case 802.11g 6Mbps.			
Channel	Frequency (MHz)	Power Spectral Density (dBm)	Limits (dBm)
Low	2412	-11.12	8 dBm
Middle	2437	-11.48	8 dBm
High	2462	-11.53	8 dBm

The spectrum analyzer plots are attached as below.

802.11b Channel Low 2412MHz



\*RBW 3 kHz    Marker 1 [T1 ]  
VBW 10 kHz    6.35 dBm  
\*SWT 100 s    2.410956400 GHz

Ref 30 dBm

Att 60 dB

1 PK  
MAXH

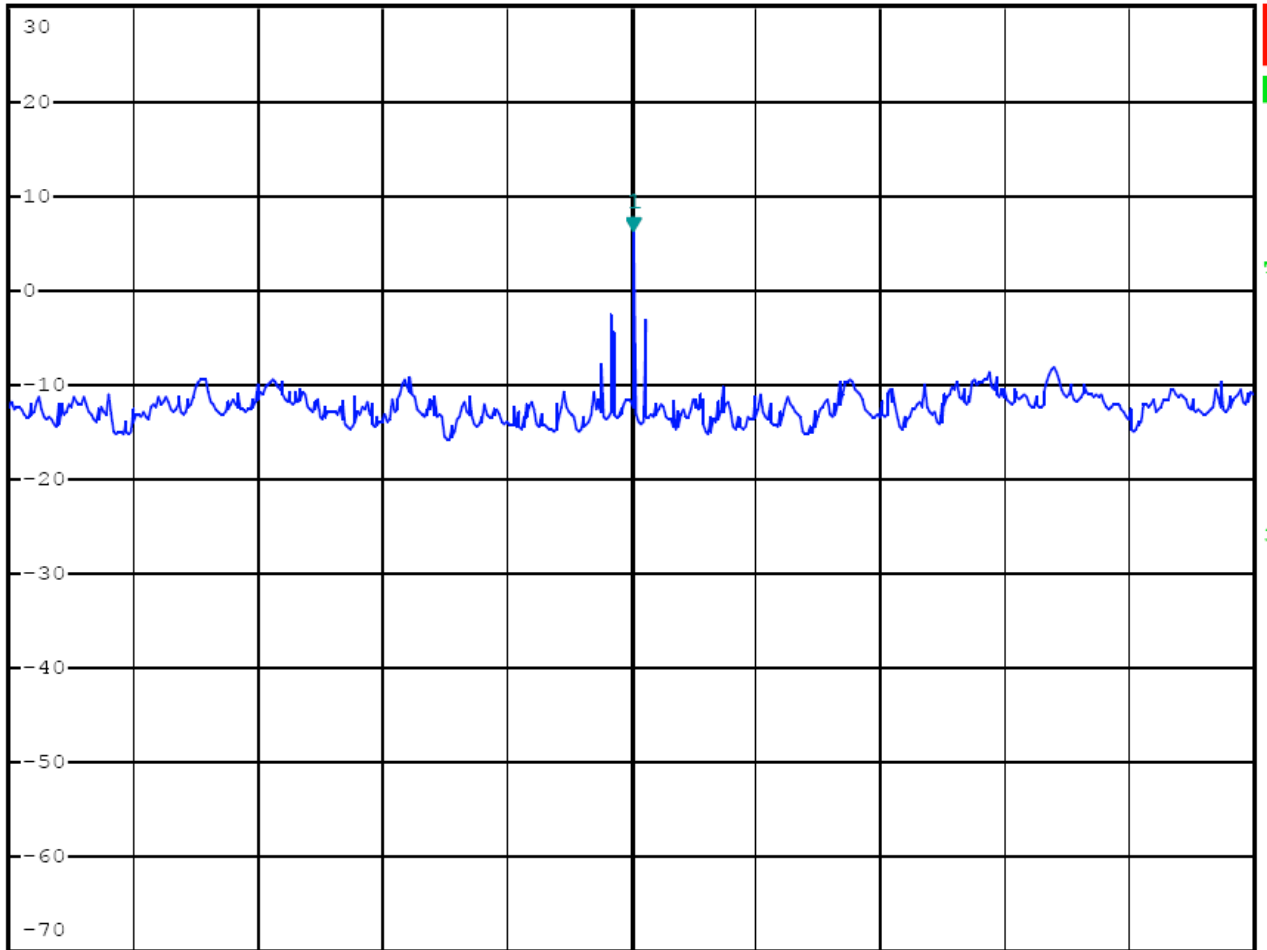

Center 2.4109558 GHz

30 kHz/

Span 300 kHz

802.11b Channel Middle 2437MHz



\*RBW 3 kHz      Marker 1 [T1 ]  
VBW 10 kHz      4.42 dBm  
\*SWT 100 s      2.435952800 GHz

Ref 30 dBm

Att 60 dB

1 PK  
MAXH

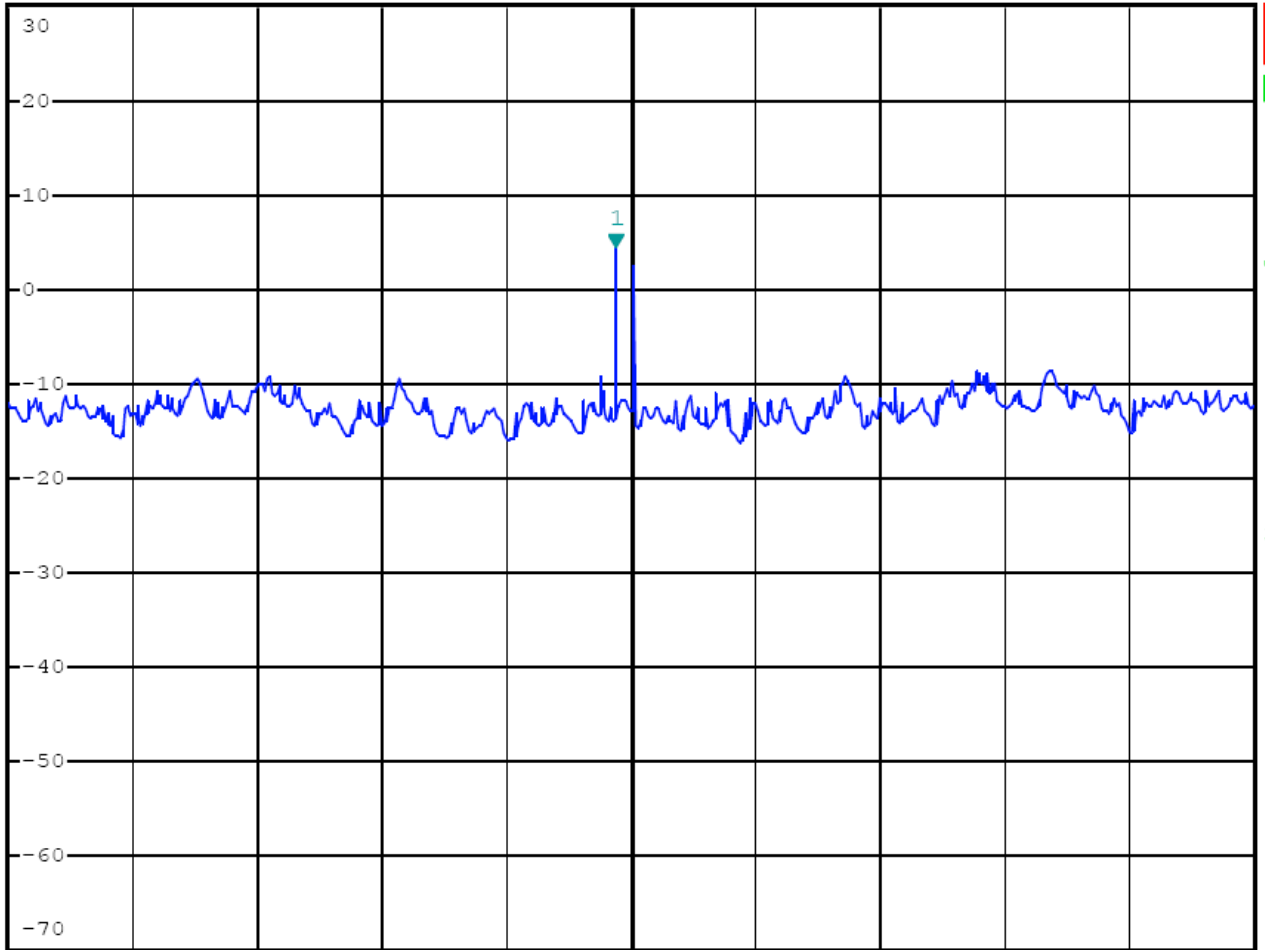

Center 2.4359564 GHz

30 kHz/

Span 300 kHz

802.11b Channel High 2462MHz



\*RBW 3 kHz      Marker 1 [T1 ]  
VBW 10 kHz      3.67 dBm  
\*SWT 100 s      2.460956100 GHz

Ref 30 dBm

Att 60 dB

1 PK  
MAXH

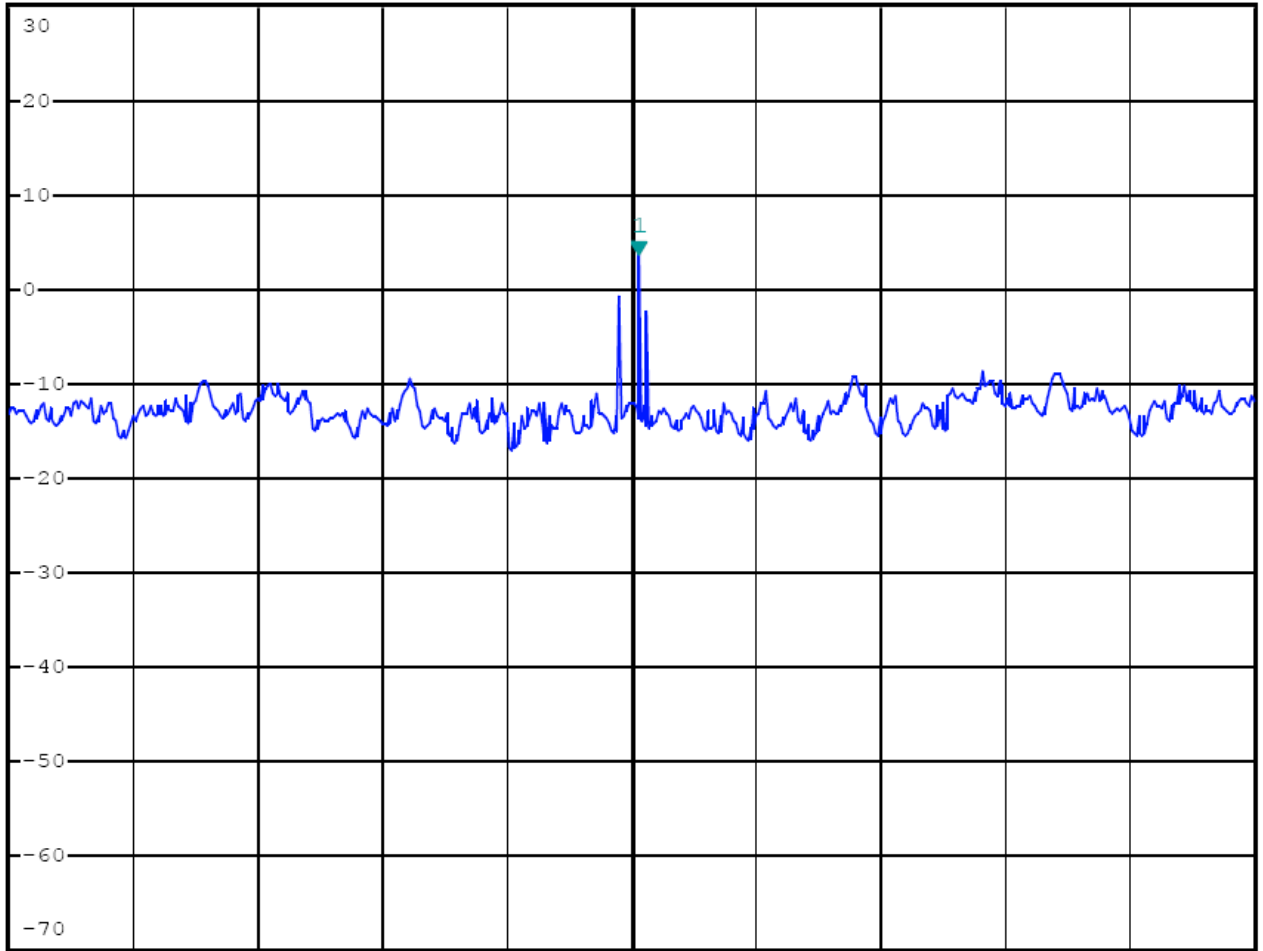

Center 2.4609543 GHz

30 kHz/

Span 300 kHz

802.11g Channel Low 2412MHz



\*RBW 3 kHz      Marker 1 [T1 ]  
VBW 10 kHz      -11.12 dBm  
\*SWT 100 s      2.404769600 GHz

Ref 30 dBm

Att 60 dB

1 PK  
MAXH

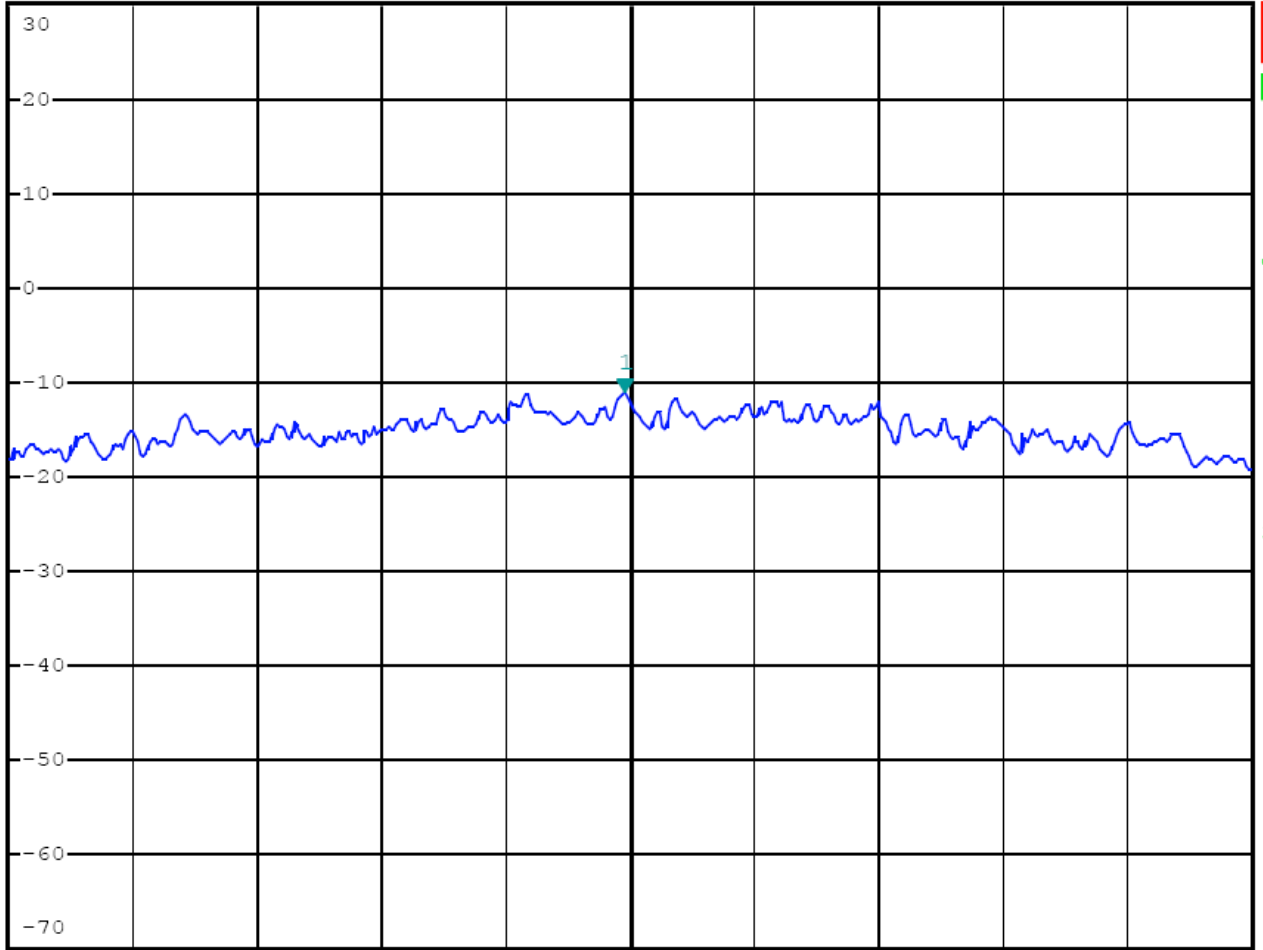

Center 2.4047708 GHz

30 kHz/

Span 300 kHz

802.11g Channel Middle 2437MHz



\*RBW 3 kHz      Marker 1 [T1 ]  
VBW 10 kHz      -11.48 dBm  
\*SWT 100 s      2.429768600 GHz

Ref 30 dBm

Att 60 dB

1 PK  
MAXH

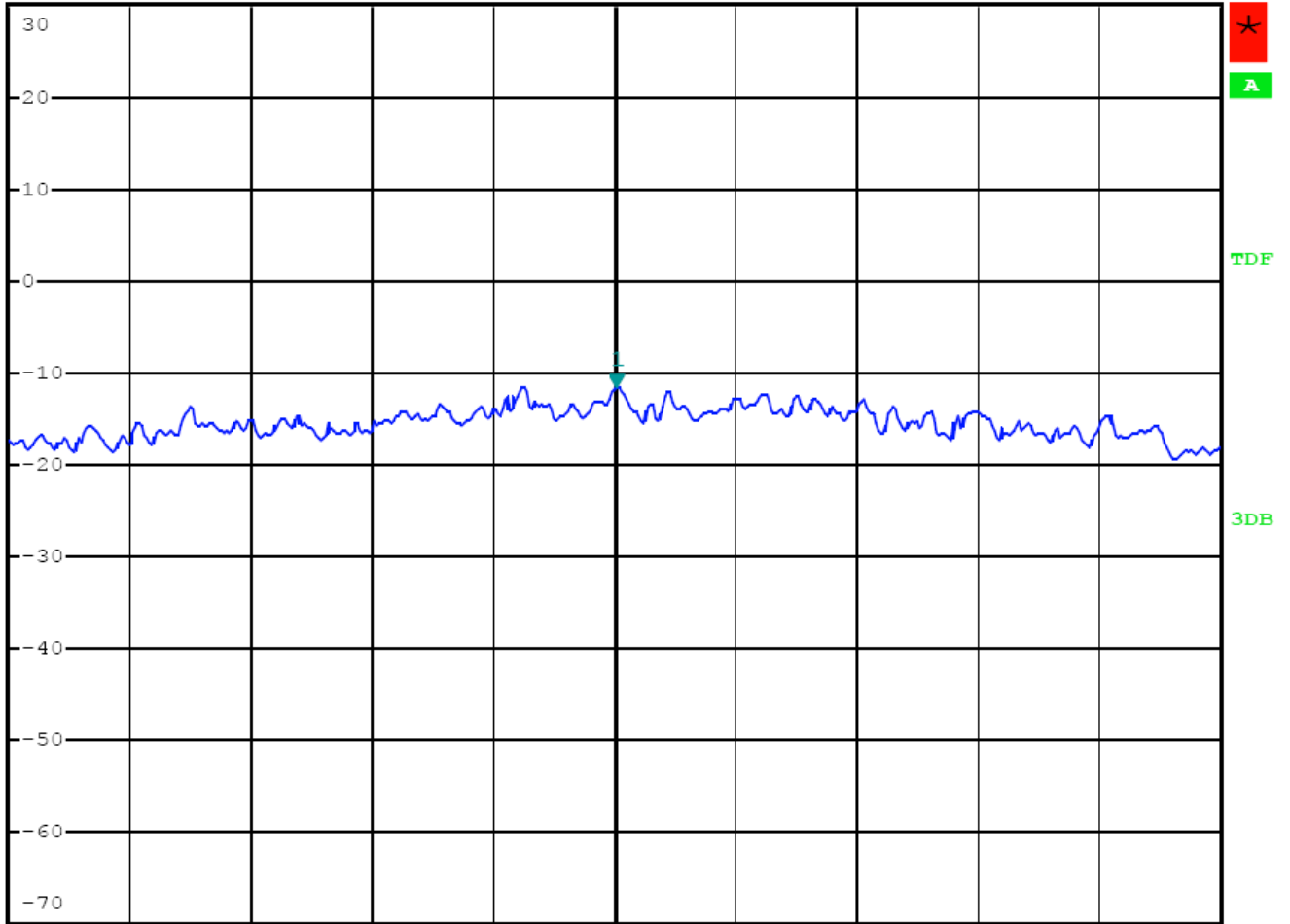

Center 2.429768 GHz

30 kHz/

Span 300 kHz



### 802.11g Channel High 2462MHz



\*RBW 3 kHz      Marker 1 [T1 ]  
VBW 10 kHz      -11.53 dBm  
\*SWT 100 s      2.454744800 GHz

Ref 30 dBm

Att 60 dB

L PK  
MAXH

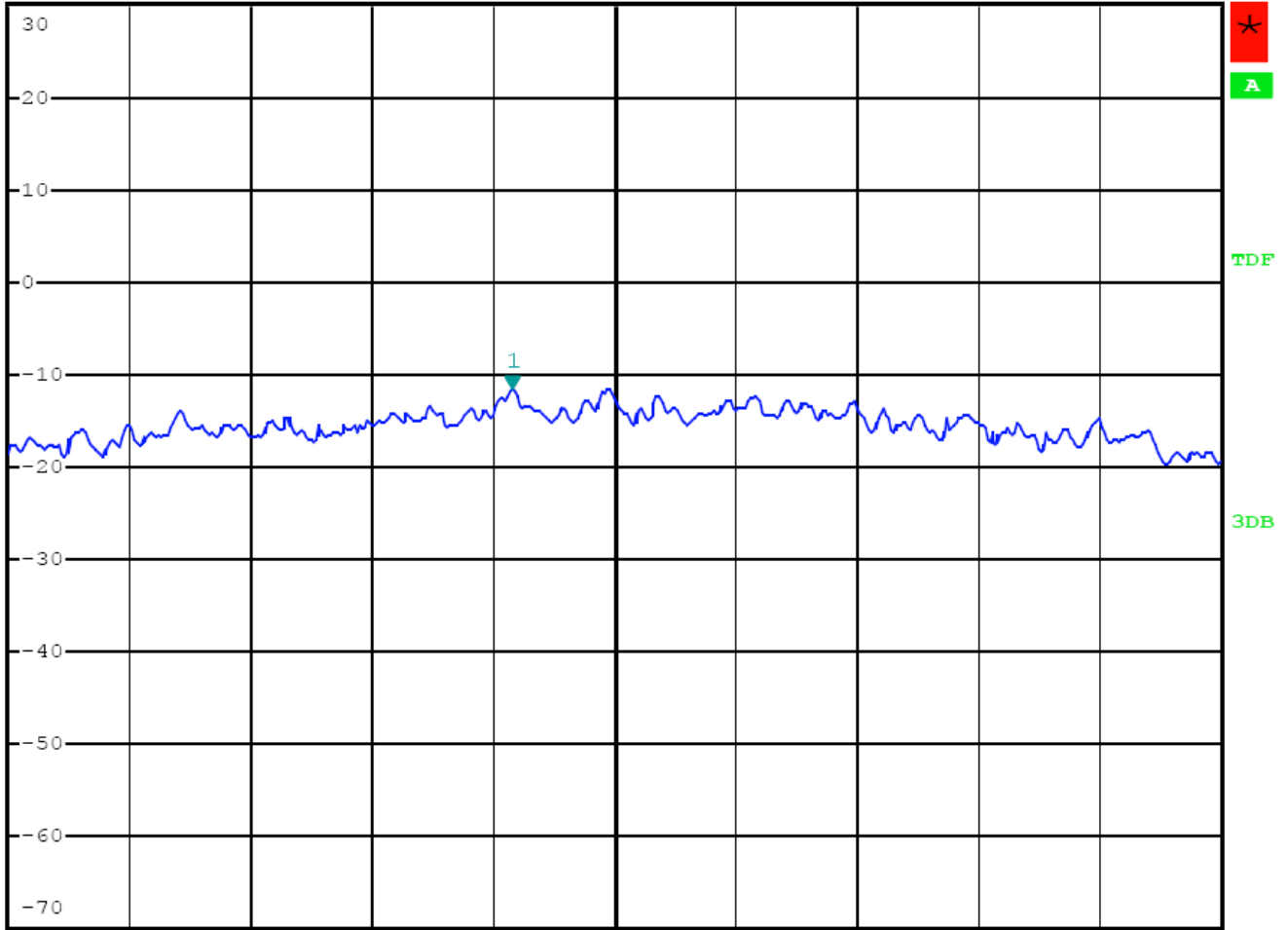

Center 2.45477 GHz

30 kHz/

Span 300 kHz

## 8. BAND EDGE COMPLIANCE TEST (WI-FI)

### 8.1. Block Diagram of Test Setup



(EUT: GuruPlug)

### 8.2. The Requirement For Section 15.247(d)

Section 15.247(d): In any 100 kHz bandwidth outside the frequency band in which the spread spectrum or digitally modulated intentional radiator is operating, the radio frequency power that is produced by the intentional radiator shall be at least 20 dB below that in the 100 kHz bandwidth within the band that contains the highest level of the desired power, based on either an RF conducted or a radiated measurement, provided the transmitter demonstrates compliance with the peak conducted power limits. If the transmitter complies with the conducted power limits based on the use of RMS averaging over a time interval, as permitted under paragraph (b)(3) of this section, the attenuation required under this paragraph shall be 30 dB instead of 20 dB. Attenuation below the general limits specified in Section 15.209(a) is not required. In addition, radiated emissions which fall in the restricted bands, as defined in Section 15.205(a), must also comply with the radiated emission limits specified in Section 15.209(a).

### 8.3. EUT Configuration on Measurement

The following equipment are installed on the emission Measurement to meet the commission requirements and operating regulations in a manner which tends to maximize its emission characteristics in normal application.

#### 8.3.1. GuruPlug (EUT)

Model Number	:	003-GP11A101
Serial Number	:	N/A
Manufacturer	:	Globalscale Technologies INC

## 8.4. Operating Condition of EUT

8.4.1. Setup the EUT and simulator as shown as Section 8.1.

8.4.2. Turn on the power of all equipment.

8.4.3. Let the EUT work in TX modes measure it. The transmit frequency are 2412-2462MHz. We select 2412MHz, 2462MHz TX frequency to transmit.

## 8.5. Test Procedure

8.5.1. The transmitter output was connected to the spectrum analyzer via a low loss cable.

8.5.2. Set RBW of spectrum analyzer to 100kHz and VBW to 300kHz with convenient frequency span.

8.5.3. The band edges was measured and recorded.

## 8.6. Test Result

**Pass**

Date of Test:	<u>April 16, 2010</u>	Temperature:	<u>25°C</u>
EUT:	<u>GuruPlug</u>	Humidity:	<u>50%</u>
Model No.:	<u>003-GP11A101</u>	Power Supply:	<u>AC 120V/60HZ</u>
Test Mode:	<u>TX</u>	Test Engineer:	<u>Joe</u>

The test was performed with 802.11b, the data was shown the worst case 802.11b 1Mbps.

Frequency (MHz)	Result of Band Edge (dBc)	Limit of Band Edge (dBc)
2412	26.42	> 20dBc
2462	39.41	> 20dBc

The test was performed with 802.11g, the data was shown the worst case 802.11g 1Mbps.

Frequency (MHz)	Result of Band Edge (dBc)	Limit of Band Edge (dBc)
2412	21.24	> 20dBc
2462	29.35	> 20dBc

802.11b Channel Low 2412MHz



\*RBW 100 kHz Delta 2 [T1 ]  
VBW 300 kHz -26.42 dB  
SWT 10 ms -14.080000000 MHz

Ref 30 dBm

Att 60 dB

SWT 10 ms

-14.080000000 MHz

1 PK  
MAXH

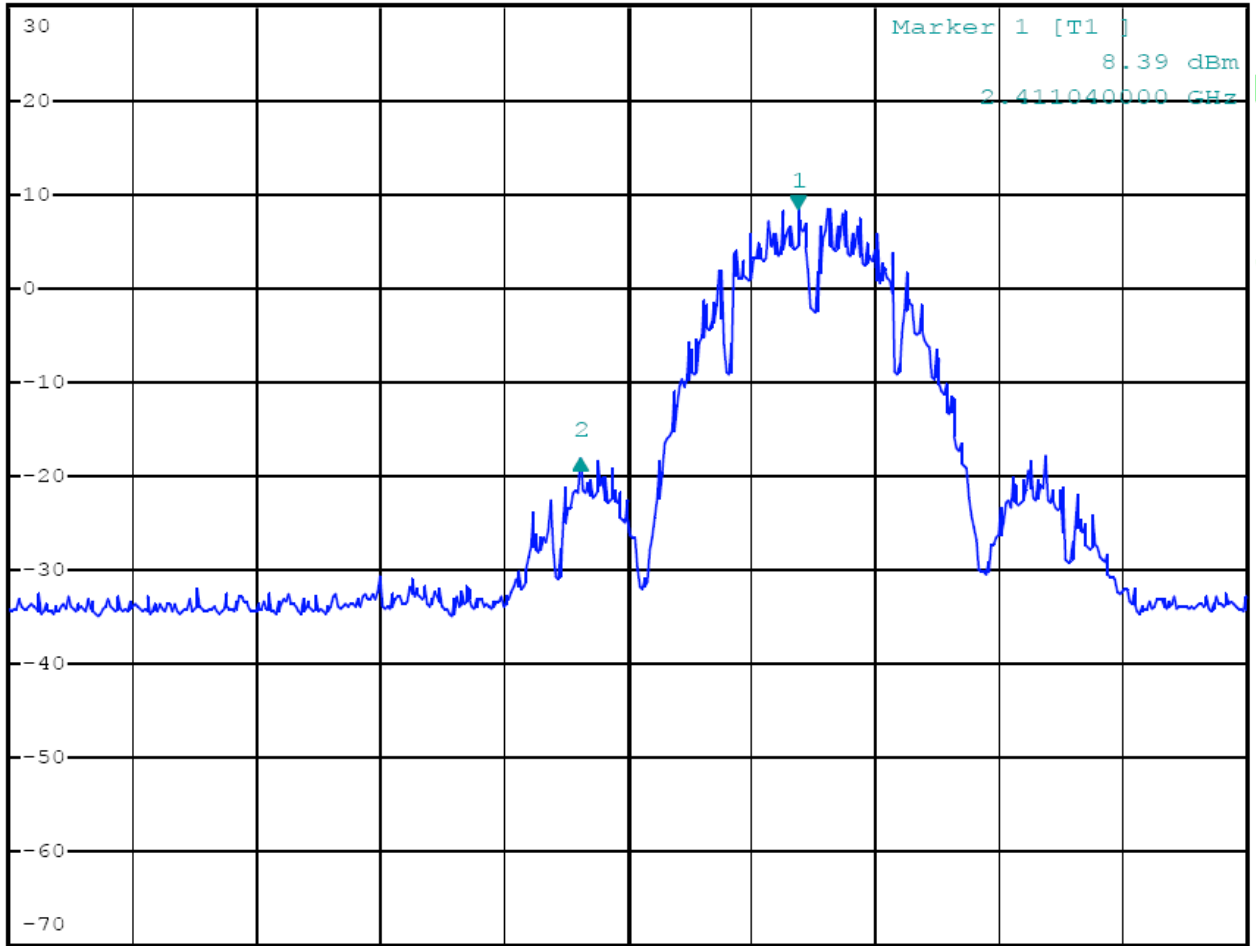

Center 2.4 GHz

8 MHz/

Span 80 MHz

### 802.11b Channel High 2462MHz



\*RBW 100 kHz Delta 2 [T1 ]  
VBW 300 kHz -39.41 dB  
SWT 10 ms 29.760000000 MHz

Ref 30 dBm

Att 60 dB

1 PR  
MAXH

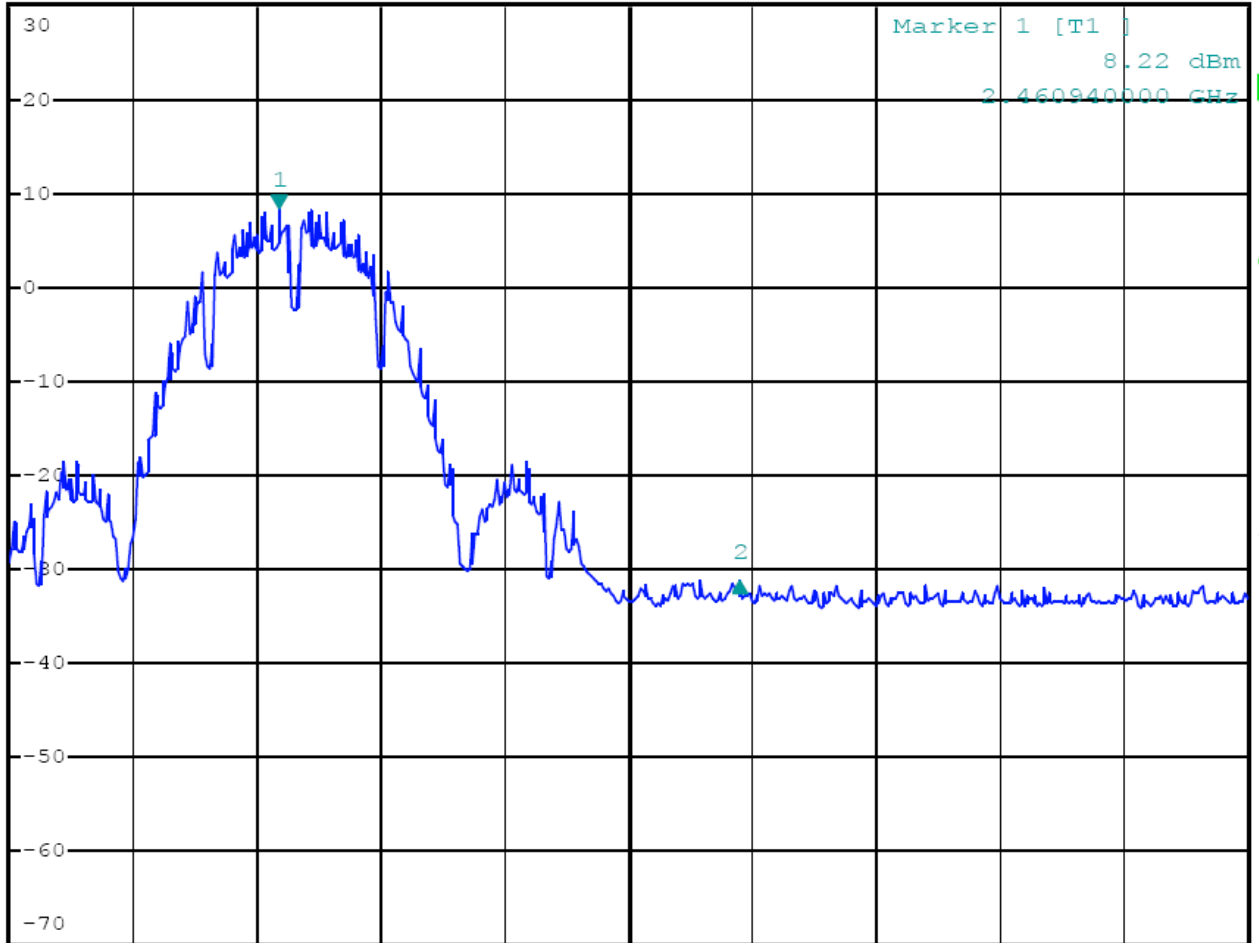

Center 2.4835 GHz

8 MHz/

Span 80 MHz

802.11g Channel Low 2412MHz



\*RBW 100 kHz Delta 2 [T1 ]  
VBW 300 kHz -21.24 dB  
SWT 10 ms -5.600000000 MHz

Ref 30 dBm

Att 60 dB

SWT 10 ms

-5.600000000 MHz

1 PK  
MAXH

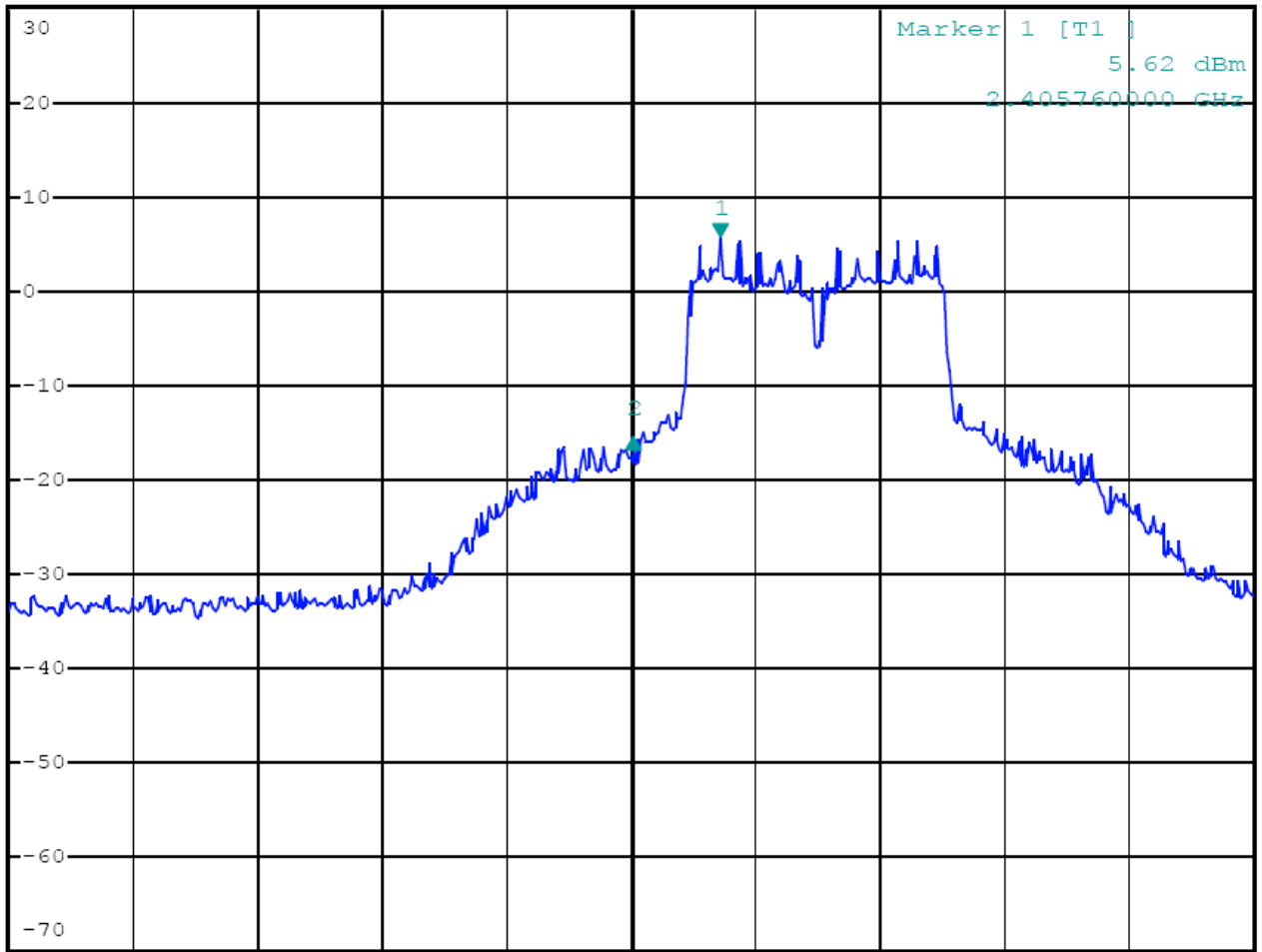

Center 2.4 GHz

8 MHz/

Span 80 MHz

### 802.11g Channel High 2462MHz



\*RBW 100 kHz Delta 2 [T1 ]  
VBW 300 kHz -29.35 dB  
SWT 10 ms 27.840000000 MHz

Ref 30 dBm

Att 60 dB

1 PK  
MAXH

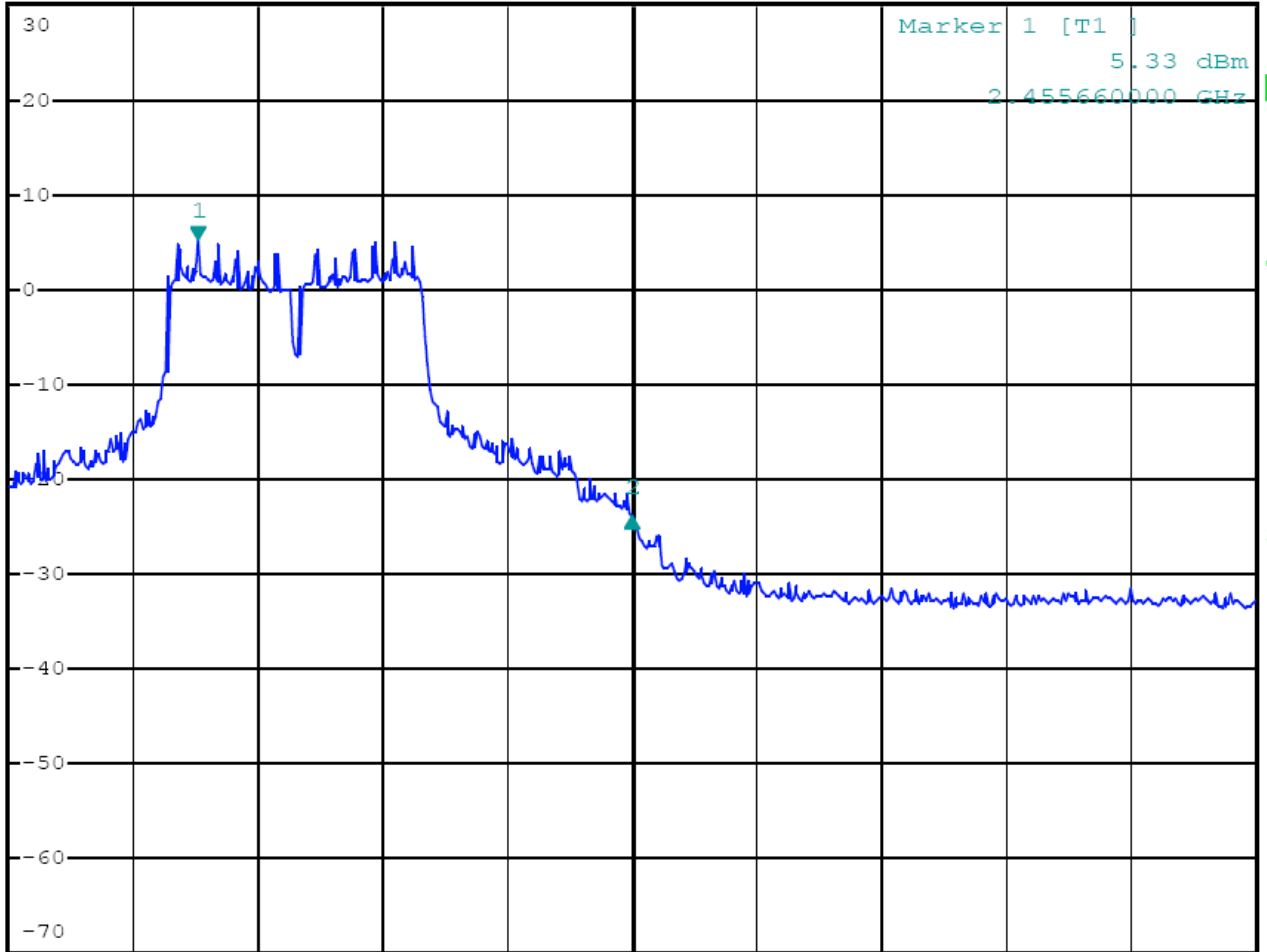

Center 2.4835 GHz

8 MHz/

Span 80 MHz



## 9. RADIATED SPURIOUS EMISSION TEST

### 9.1. Block Diagram of Test Setup

#### 9.1.1. Block diagram of connection between the EUT and simulators

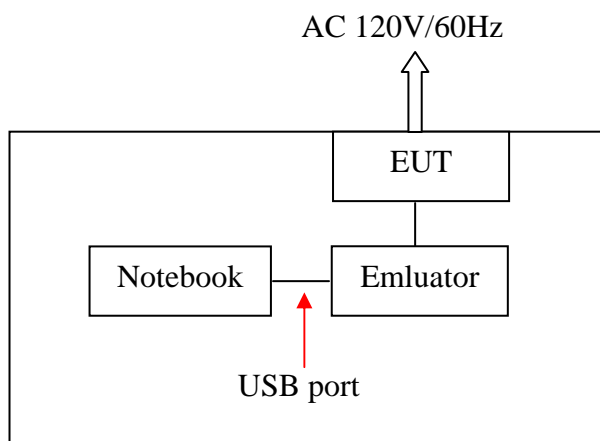

Setup: Transmitting mode

(EUT: GuruPlug)

#### 9.1.2. Semi-Anechoic Chamber Test Setup Diagram

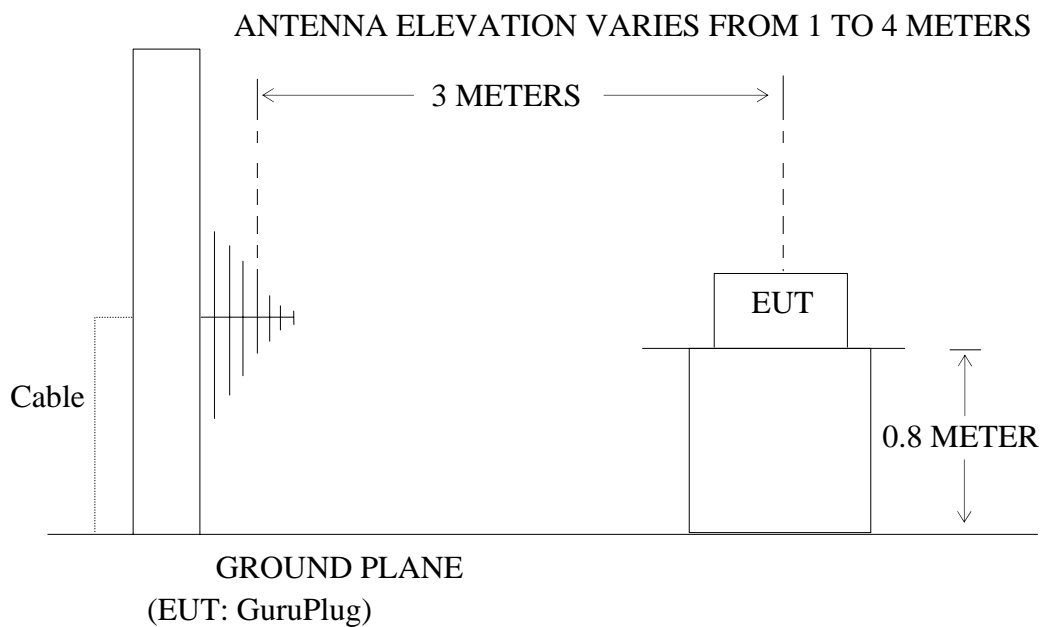

(EUT: GuruPlug)

## 9.2.The Limit For Section 15.247(d)

Section 15.247(d): In any 100 kHz bandwidth outside the frequency band in which the spread spectrum or digitally modulated intentional radiator is operating, the radio frequency power that is produced by the intentional radiator shall be at least 20 dB below that in the 100 kHz bandwidth within the band that contains the highest level of the desired power, based on either an RF conducted or a radiated measurement, provided the transmitter demonstrates compliance with the peak conducted power limits. If the transmitter complies with the conducted power limits based on the use of RMS averaging over a time interval, as permitted under paragraph (b)(3) of this section, the attenuation required under this paragraph shall be 30 dB instead of 20 dB. Attenuation below the general limits specified in Section 15.209(a) is not required. In addition, radiated emissions which fall in the restricted bands, as defined in Section 15.205(a), must also comply with the radiated emission limits specified in Section 15.209(a).

## 9.3.Restricted bands of operation

### 9.3.1.FCC Part 15.205 Restricted bands of operation

(a) Except as shown in paragraph (d) of this section, Only spurious emissions are permitted in any of the frequency bands listed below:

MHz	MHz	MHz	GHz
0.090-0.110	16.42-16.423	399.9-410	4.5-5.15
<sup>1</sup> 0.495-0.505	16.69475-16.69525	608-614	5.35-5.46
2.1735-2.1905	16.80425-16.80475	960-1240	7.25-7.75
4.125-4.128	25.5-25.67	1300-1427	8.025-8.5
4.17725-4.17775	37.5-38.25	1435-1626.5	9.0-9.2
4.20725-4.20775	73-74.6	1645.5-1646.5	9.3-9.5
6.215-6.218	74.8-75.2	1660-1710	10.6-12.7
6.26775-6.26825	108-121.94	1718.8-1722.2	13.25-13.4
6.31175-6.31225	123-138	2200-2300	14.47-14.5
8.291-8.294	149.9-150.05	2310-2390	15.35-16.2
8.362-8.366	156.52475-156.52525	2483.5-2500	17.7-21.4
8.37625-8.38675	156.7-156.9	2690-2900	22.01-23.12
8.41425-8.41475	162.0125-167.17	3260-3267	23.6-24.0
12.29-12.293	167.72-173.2	3332-3339	31.2-31.8
12.51975-12.52025	240-285	3345.8-3358	36.43-36.5
12.57675-12.57725	322-335.4	3600-4400	( <sup>2</sup> )
13.36-13.41			

<sup>1</sup>Until February 1, 1999, this restricted band shall be 0.490-0.510

<sup>2</sup>Above 38.6

(b) Except as provided in paragraphs (d) and (e), the field strength of emission appearing within these frequency bands shall not exceed the limits shown in Section 15.209. At frequencies equal to or less than 1000MHz, Compliance with the limits in Section 15.209 shall be demonstrated using measurement instrumentation employing a CISPR quasi-peak detector. Above 1000MHz, compliance with the emission limits in Section 15.209 shall be demonstrated based on the average value of the measured emissions. The provisions in Section 15.35 apply to these measurements.

## 9.4. Configuration of EUT on Measurement

The following equipment are installed on Radiated Emission Measurement to meet the commission requirements and operating regulations in a manner which tends to maximize its emission characteristics in normal application.

### 9.4.1. GuruPlug (EUT)

Model Number : 003-GP11A101  
 Serial Number : N/A  
 Manufacturer : Globalscale Technologies INC

## 9.5. Operating Condition of EUT

9.5.1. Setup the EUT and simulator as shown as Section 8.1.

9.5.2. Turn on the power of all equipment.

9.5.3. Let the EUT work in TX modes measure it. The transmit frequency are 2412-2462MHz. We select 2412MHz, 2437MHz, 2462MHz TX frequency to transmit.

## 9.6. Test Procedure

The EUT and its simulators are placed on a turntable, which is 0.8 meter high above ground. The turntable can rotate 360 degrees to determine the position of the maximum emission level. EUT is set 3.0 meters away from the receiving antenna, which is mounted on an antenna tower. The antenna can be moved up and down between 1.0 meter and 4 meters to find out the maximum emission level. Broadband antenna (calibrated bilog antenna) is used as receiving antenna. Both horizontal and vertical polarizations of the antenna are set on measurement. In order to find the maximum emission levels, all of the interface cables must be manipulated according to ANSI C63.4: 2003 on radiated emission measurement. The EUT was tested in 3 orthogonal planes.

The worst-case data rate for this channel to be 1Mbps for 802.11b mode and 6Mbps for 802.11g mode, based on previous with 802.11 WLAN product design architectures.

The bandwidth of test receiver (R&S ESI26) is set at 120kHz in 30-1000MHz. and set at 1MHz in above 1000MHz.

The frequency range from 30MHz to 25000MHz is checked.

The final measurement in band 9-90kHz, 110-490kHz and above 1000MHz is performed with Average detector. Except those frequency bands mention above, the final measurement for frequencies below 1000MHz is performed with Quasi Peak detector.

The field strength is calculated by adding the antenna factor, and cable loss, and subtracting the amplifier gain from the measured reading. The basic equation calculation is as follows:

Result = Reading + Corrected Factor

Where Corrected Factor = Antenna Factor + Cable Loss – Amplifier Gain

## 9.7. The Field Strength of Radiation Emission Measurement Results

**PASS.**

Date of Test:	<u>April 16-17, 2010</u>	Temperature:	<u>25°C</u>
EUT:	<u>GuruPlug</u>	Humidity:	<u>50%</u>
Model No.:	<u>003-GP11A101</u>	Power Supply:	<u>AC 120V/60HZ</u>
Test Mode:	<u>802.11b Channel Low 2412MHz</u>	Test Engineer:	<u>Joe</u>

**For 30MHz-1000MHz**

Corrected Factor = Antenna Factor + Cable Loss – Amplifier Gain

Frequency (MHz)	Reading (dB $\mu$ V/m)	Factor Corr. (dB)	Result (dB $\mu$ V/m)	Limit (dB $\mu$ V/m)	Margin (dB)	Polarization
	QP		QP	QP	QP	
-	-	-	-	-	-	Vertical
-	-	-	-	-	-	Horizontal

**For 1GHz-25GHz**

Corrected Factor = Antenna Factor + Cable Loss – Amplifier Gain

Frequency (MHz)	Reading(dB $\mu$ V/m)		Factor Corr. (dB)	Result(dB $\mu$ V/m)		Limit(dB $\mu$ V/m)		Margin(dB $\mu$ V/m)		Polarization
	AV	PEAK		AV	PEAK	AV	PEAK	AV	PEAK	
2400.000	43.31	49.30	-7.46	35.85	41.84	54	74	-18.15	-32.16	Vertical
2412.016	106.10	112.17	-7.43	98.67	104.74	-	-	-	-	Vertical
*4824.027	50.41	56.49	-0.19	50.22	56.30	54	74	-3.78	-17.70	Vertical
7236.035	43.35	49.47	3.05	46.40	52.52	54	74	-7.60	-21.48	Vertical
2400.000	42.21	48.22	-7.46	34.75	40.76	54	74	-19.25	-33.24	Horizontal
2412.016	105.90	111.99	-7.43	98.47	104.56	-	-	-	-	Horizontal
*4824.027	48.24	54.30	-0.19	48.05	54.11	54	74	-5.95	-19.89	Horizontal
7236.035	39.54	45.56	3.05	42.69	48.61	54	74	-11.41	-25.39	Horizontal

**Note: 1. Emissions attenuated more than 20 dB below the permissible value are not reported.****2. \*: Denotes restricted band of operation.**

Date of Test:	April 16-17, 2010	Temperature:	25°C
EUT:	GuruPlug	Humidity:	50%
Model No.:	003-GP11A101	Power Supply:	AC 120V/60Hz
Test Mode:	802.11b Channel Middle 2437MHz	Test Engineer:	Joe

**For 30MHz-1000MHz**

Corrected Factor = Antenna Factor + Cable Loss – Amplifier Gain

Frequency (MHz)	Reading (dBμV/m)	Factor Corr. (dB)	Result (dBμV/m)	Limit (dBμV/m)	Margin (dB)	Polarization
	QP		QP	QP	QP	
-	-	-	-	-	-	Vertical
-	-	-	-	-	-	Horizontal

**For 1GHz-25GHz**

Corrected Factor = Antenna Factor + Cable Loss – Amplifier Gain

Frequency (MHz)	Reading(dBμV/m)		Factor Corr. (dB)	Result(dBμV/m)		Limit(dBμV/m)		Margin(dBμV/m)		Polarization
	AV	PEAK		AV	PEAK	AV	PEAK	AV	PEAK	
2437.015	106.09	112.22	-7.36	98.73	104.86	-	-	-	-	Vertical
*4874.027	47.84	53.89	0.09	47.93	53.98	54	74	-6.07	-20.02	Vertical
*7311.034	41.02	47.14	3.22	44.24	50.36	54	74	-9.76	-23.64	Vertical
2437.015	105.81	111.88	-7.36	98.45	104.52	-	-	-	-	Horizontal
*4874.027	47.94	54.02	0.09	48.03	54.11	54	74	-5.97	-19.89	Horizontal
*7311.034	39.77	45.79	3.22	42.99	49.01	54	74	-11.01	-24.99	Horizontal

**Note: 1. Emissions attenuated more than 20 dB below the permissible value are not reported.****2. \*: Denotes restricted band of operation.**

Date of Test:	April 16-17, 2010	Temperature:	25°C
EUT:	GuruPlug	Humidity:	50%
Model No.:	003-GP11A101	Power Supply:	AC 120V/60Hz
Test Mode:	802.11b Channel High 2462MHz	Test Engineer:	Joe

**For 30MHz-1000MHz**

Corrected Factor = Antenna Factor + Cable Loss – Amplifier Gain

Frequency (MHz)	Reading (dBμV/m)	Factor Corr. (dB)	Result (dBμV/m)	Limit (dBμV/m)	Margin (dB)	Polarization
	QP		QP	QP	QP	
-	-	-	-	-	-	Vertical
-	-	-	-	-	-	Horizontal

**For 1GHz-25GHz**

Corrected Factor = Antenna Factor + Cable Loss – Amplifier Gain

Frequency (MHz)	Reading(dBμV/m)		Factor Corr. (dB)	Result(dBμV/m)		Limit(dBμV/m)		Margin(dBμV/m)		Polarization
	AV	PEAK		AV	PEAK	AV	PEAK	AV	PEAK	
2462.016	106.31	112.38	-7.35	98.96	105.03	-	-	-	-	Vertical
*2483.500	40.96	47.00	-7.37	33.59	39.63	54	74	-20.41	-34.37	Vertical
*4924.026	48.49	54.62	0.34	48.83	54.96	54	74	-5.17	-19.04	Vertical
*7386.035	40.76	46.79	3.39	44.15	50.18	54	74	-9.85	-23.82	Vertical
2462.016	106.30	112.43	-7.35	98.95	105.08	-	-	-	-	Horizontal
*2483.500	41.33	47.37	-7.37	33.96	40.00	54	74	-20.04	-34.00	Horizontal
*4924.026	47.95	54.01	0.34	48.29	54.35	54	74	-5.71	-19.65	Horizontal
*7386.035	37.82	43.88	3.39	41.21	47.27	54	74	-12.79	-26.73	Horizontal

**Note: 1. Emissions attenuated more than 20 dB below the permissible value are not reported.****2. \*: Denotes restricted band of operation.**

Date of Test:	April 16-17, 2010	Temperature:	25°C
EUT:	GuruPlug	Humidity:	50%
Model No.:	003-GP11A101	Power Supply:	AC 120V/60HZ
Test Mode:	802.11g Channel Low 2412MHz	Test Engineer:	Joe

**For 30MHz-1000MHz**

Corrected Factor = Antenna Factor + Cable Loss – Amplifier Gain

Frequency (MHz)	Reading (dBμV/m)	Factor Corr. (dB)	Result (dBμV/m)	Limit (dBμV/m)	Margin (dB)	Polarization
	QP		QP	QP	QP	
-	-	-	-	-	-	Vertical
-	-	-	-	-	-	Horizontal

**For 1GHz-25GHz**

Corrected Factor = Antenna Factor + Cable Loss – Amplifier Gain

Frequency (MHz)	Reading(dBμV/m)		Factor Corr. (dB)	Result(dBμV/m)		Limit(dBμV/m)		Margin(dBμV/m)		Polarization
	AV	PEAK		AV	PEAK	AV	PEAK	AV	PEAK	
2400.000	42.54	48.59	-7.46	35.08	41.13	54	74	-18.92	-32.87	Vertical
2412.016	106.77	112.89	-7.43	99.34	105.46	-	-	-	-	Vertical
*4824.027	48.67	54.76	-0.19	48.48	54.57	54	74	-5.52	-19.43	Vertical
7236.035	39.10	45.15	3.05	42.15	48.20	54	74	-11.85	-25.80	Vertical
2400.000	43.75	49.86	-7.46	36.29	42.40	54	74	-17.71	-31.60	Horizontal
2412.016	106.32	112.41	-7.43	98.89	104.98	-	-	-	-	Horizontal
*4824.027	49.02	55.09	-0.19	48.83	54.90	54	74	-5.17	-19.10	Horizontal

**Note: 1. Emissions attenuated more than 20 dB below the permissible value are not reported.****2. \*: Denotes restricted band of operation.**

Date of Test:	<u>April 16-17, 2010</u>	Temperature:	<u>25°C</u>
EUT:	<u>GuruPlug</u>	Humidity:	<u>50%</u>
Model No.:	<u>003-GP11A101</u>	Power Supply:	<u>AC 120V/60Hz</u>
Test Mode:	<u>802.11g Channel Middle 2437MHz</u>	Test Engineer:	<u>Joe</u>

**For 30MHz-1000MHz**

Corrected Factor = Antenna Factor + Cable Loss – Amplifier Gain

Frequency (MHz)	Reading (dBμV/m)	Factor Corr. (dB)	Result (dBμV/m)	Limit (dBμV/m)	Margin (dB)	Polarization
	QP		QP	QP	QP	
-	-	-	-	-	-	Vertical
-	-	-	-	-	-	Horizontal

**For 1GHz-25GHz**

Corrected Factor = Antenna Factor + Cable Loss – Amplifier Gain

Frequency (MHz)	Reading(dBμV/m)		Factor Corr. (dB)	Result(dBμV/m)		Limit(dBμV/m)		Margin(dBμV/m)		Polarization
	AV	PEAK		AV	PEAK	AV	PEAK	AV	PEAK	
2437.015	106.21	112.33	-7.36	98.85	104.97	-	-	-	-	Vertical
*4874.027	48.49	54.61	0.09	48.58	54.70	54	74	-5.42	-19.30	Vertical
*7311.034	39.72	45.85	3.22	42.94	49.07	54	74	-11.06	-24.93	Vertical
2437.015	106.58	112.74	-7.36	99.22	105.38	-	-	-	-	Horizontal
*4874.027	45.69	51.82	0.09	45.78	51.91	54	74	-8.22	-22.09	Horizontal

**Note: 1. Emissions attenuated more than 20 dB below the permissible value are not reported.****2. \*: Denotes restricted band of operation.**



Date of Test:	April 16-17, 2010	Temperature:	25°C
EUT:	GuruPlug	Humidity:	50%
Model No.:	003-GP11A101	Power Supply:	AC 120V/60Hz
Test Mode:	802.11g Channel High 2462MHz	Test Engineer:	Joe

**For 30MHz-1000MHz**

Corrected Factor = Antenna Factor + Cable Loss – Amplifier Gain

Frequency (MHz)	Reading (dBμV/m)	Factor Corr. (dB)	Result (dBμV/m)	Limit (dBμV/m)	Margin (dB)	Polarization
	QP		QP	QP	QP	
-	-	-	-	-	-	Vertical
-	-	-	-	-	-	Horizontal

**For 1GHz-25GHz**

Corrected Factor = Antenna Factor + Cable Loss – Amplifier Gain

Frequency (MHz)	Reading(dBμV/m)		Factor Corr. (dB)	Result(dBμV/m)		Limit(dBμV/m)		Margin(dBμV/m)		Polarization
	AV	PEAK		AV	PEAK	AV	PEAK	AV	PEAK	
2462.016	106.34	112.46	-7.35	98.99	105.11	-	-	-	-	Vertical
*2483.500	41.77	47.92	-7.37	34.40	40.55	54	74	-19.60	-33.45	Vertical
*4924.026	49.08	55.18	0.34	49.42	55.52	54	74	-4.58	-18.48	Vertical
*7386.035	41.54	47.64	3.39	44.93	51.03	54	74	-9.07	-22.97	Vertical
2462.016	106.00	112.08	-7.35	98.65	104.73	-	-	-	-	Horizontal
*2483.500	41.17	47.25	-7.37	33.80	39.88	54	74	-20.20	-34.12	Horizontal
*4924.026	47.65	53.78	0.34	47.99	54.12	54	74	-6.01	-19.88	Horizontal

**Note: 1. Emissions attenuated more than 20 dB below the permissible value are not reported.****2. \*: Denotes restricted band of operation.**



**ACCURATE TECHNOLOGY CO., LTD.**

F1,Bldg,A,Changyuan New Material Port Keyuan Rd,  
Science & Industry Park,Nanshan Shenzhen,P.R.China

Site: 966 chamber  
Tel:+86-0755-26503290  
Fax:+86-0755-26503396

Job No.: RTTE #4562	Polarization: Horizontal
Standard: FCC Class B 3M Radiated	Power Source: AC 120V/60Hz
Test item: Radiation Test	Date: 2010/04/16
Temp.( C)/Hum.(%) 25 C / 50 %	Time: 10:58:21
EUT: GuruPlug	Engineer Signature: Joe
Mode: TX Channal 1(802.11b)	Distance: 3m
Model: 003-GP11A101	
Manufacturer: Globalscale Technologies INC	

Note: Sample No.:100743 Report No.:ATE20100630

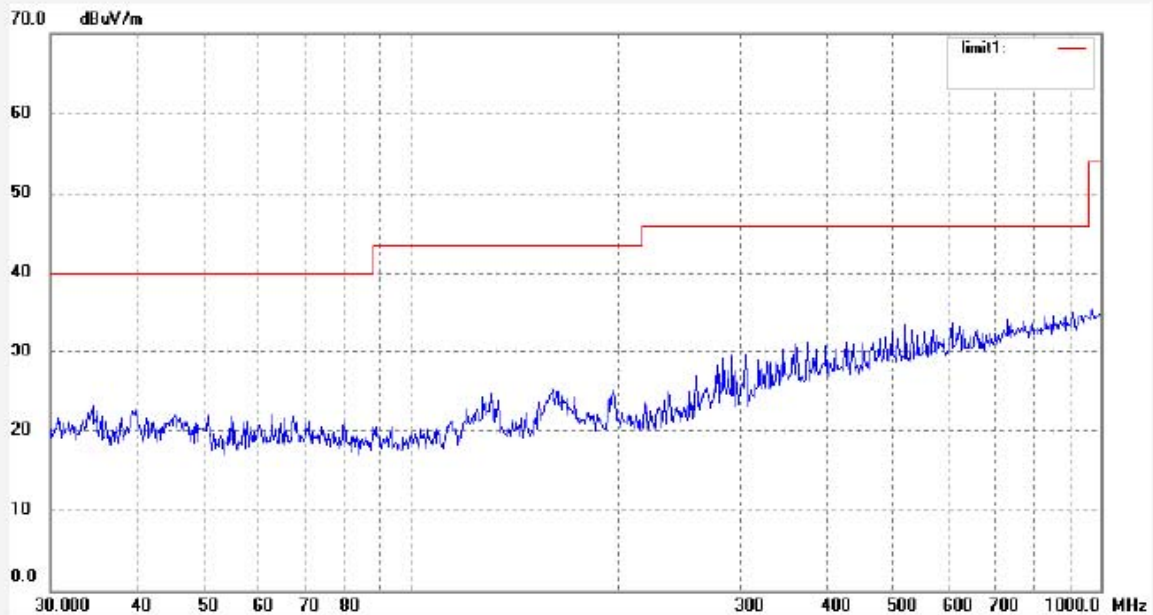

No.	Freq. (MHz)	Reading (dBuV/m)	Factor (dB)	Result (dBuV/m)	Limit (dBuV/m)	Margin (dB)	Detector	Height (cm)	Degree (deg.)	Remark
-----	-------------	------------------	-------------	-----------------	----------------	-------------	----------	-------------	---------------	--------



**ACCURATE TECHNOLOGY CO., LTD.**

F1,Bldg,A,Changyuan New Material Port Keyuan Rd,  
Science & Industry Park,Nanshan Shenzhen,P.R.China

Site: 966 chamber  
Tel:+86-0755-26503290  
Fax:+86-0755-26503396

Job No.: RTTE #4563	Polarization: Vertical
Standard: FCC Class B 3M Radiated	Power Source: AC 120V/60Hz
Test item: Radiation Test	Date: 2010/04/16
Temp.( C)/Hum.(%) 25 C / 50 %	Time: 11:02:05
EUT: GuruPlug	Engineer Signature: Joe
Mode: TX Channal 1(802.11b)	Distance: 3m
Model: 003-GP11A101	
Manufacturer: Globalscale Technologies INC	

Note: Sample No.:100743 Report No.:ATE20100630

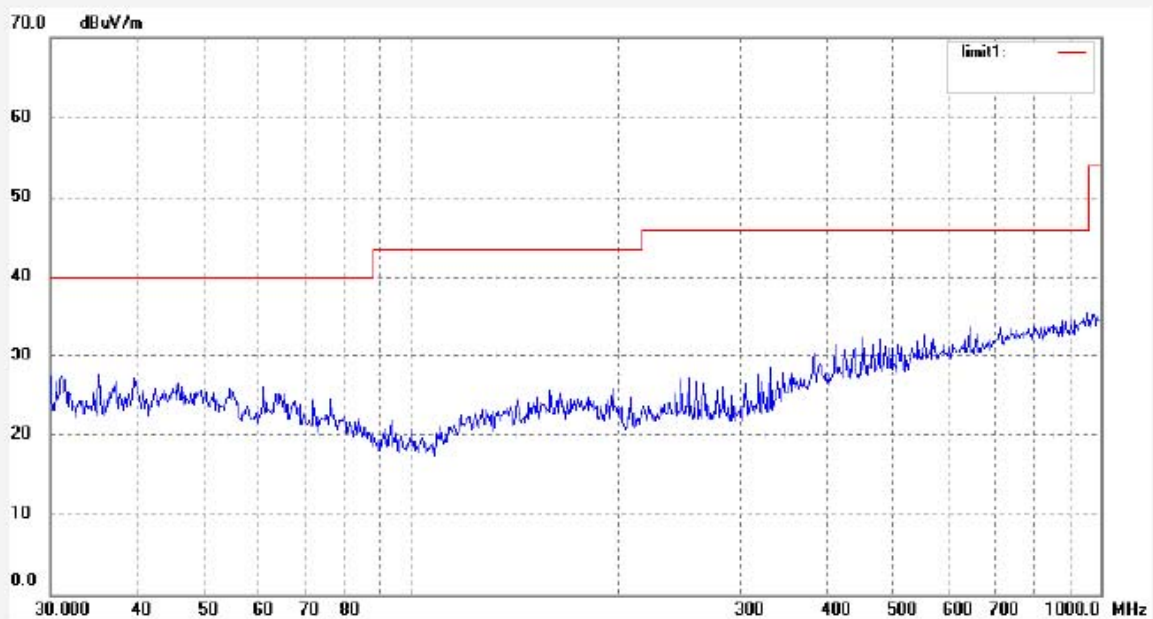

No.	Freq. (MHz)	Reading (dBuV/m)	Factor (dB)	Result (dBuV/m)	Limit (dBuV/m)	Margin (dB)	Detector	Height (cm)	Degree (deg.)	Remark
-----	-------------	------------------	-------------	-----------------	----------------	-------------	----------	-------------	---------------	--------



**ACCURATE TECHNOLOGY CO., LTD.**

F1,Bldg,A,Changyuan New Material Port Keyuan Rd,  
Science & Industry Park,Nanshan Shenzhen,P.R.China

Site: 966 chamber  
Tel:+86-0755-26503290  
Fax:+86-0755-26503396

Job No.: RTTE #4574	Polarization: Horizontal
Standard: FCC Class B 3M Radiated	Power Source: AC 120V/60Hz
Test item: Radiation Test	Date: 2010/04/17
Temp.( C)/Hum.(%) 25 C / 50 %	Time: 8:38:45
EUT: GuruPlug	Engineer Signature: Joe
Mode: TX Channal 1(802.11b)	Distance: 3m
Model: 003-GP11A101	
Manufacturer: Globalscale Technologies INC	

Note: Sample No.:100743 Report No.:ATE20100630

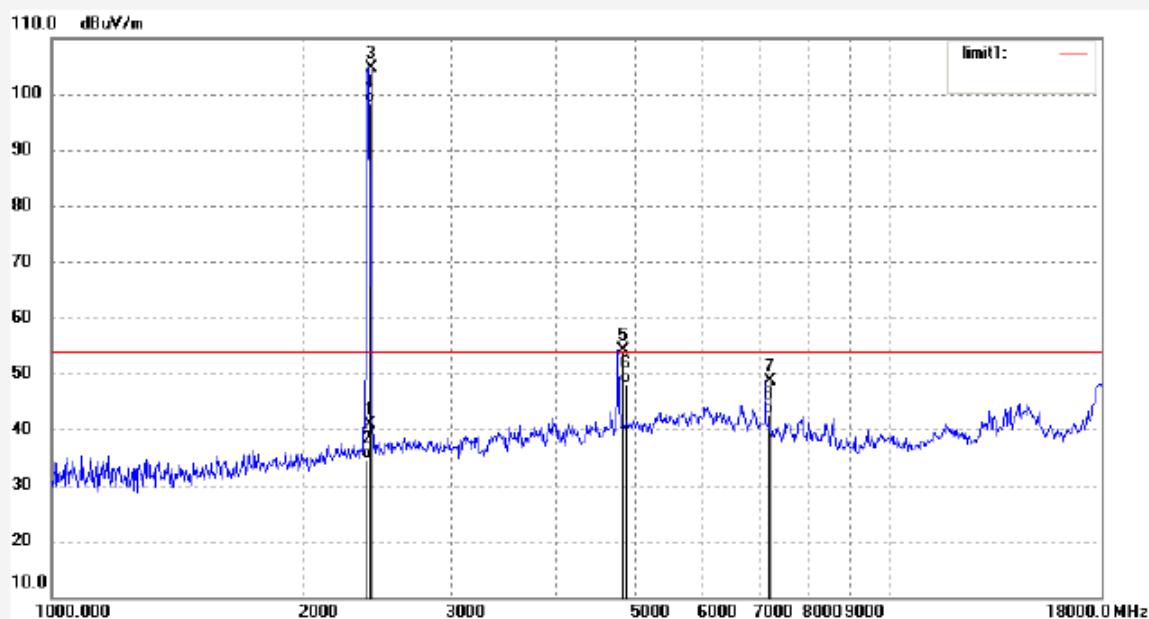

No.	Freq. (MHz)	Reading (dBuV/m)	Factor (dB)	Result (dBuV/m)	Limit (dBuV/m)	Margin (dB)	Detector	Height (cm)	Degree (deg.)	Remark
1	2400.000	48.22	-7.46	40.76	54.00	-13.24	peak			
2	2400.000	42.21	-7.46	34.75	54.00	-19.25	AVG			
3	2412.016	111.99	-7.43	104.56	54.00	50.56	peak			
4	2412.016	105.90	-7.43	98.47	54.00	44.47	AVG			
5	4824.027	54.30	-0.19	54.11	54.00	0.11	peak			
6	4824.027	48.24	-0.19	48.05	54.00	-5.95	AVG			
7	7236.035	45.56	3.05	48.61	54.00	-5.39	peak			
8	7236.035	39.54	3.05	42.59	54.00	-11.41	AVG			



**ACCURATE TECHNOLOGY CO., LTD.**

F1,Bldg,A,Changyuan New Material Port Keyuan Rd,  
Science & Industry Park,Nanshan Shenzhen,P.R.China

Site: 966 chamber  
Tel:+86-0755-26503290  
Fax:+86-0755-26503396

Job No.: RTTE #4575	Polarization: Vertical
Standard: FCC Class B 3M Radiated	Power Source: AC 120V/60Hz
Test item: Radiation Test	Date: 2010/04/17
Temp.( C)/Hum.(%) 25 C / 50 %	Time: 8:42:50
EUT: GuruPlug	Engineer Signature: Joe
Mode: TX Channal 1(802.11b)	Distance: 3m
Model: 003-GP11A101	
Manufacturer: Globalscale Technologies INC	

Note: Sample No.:100743 Report No.:ATE20100630

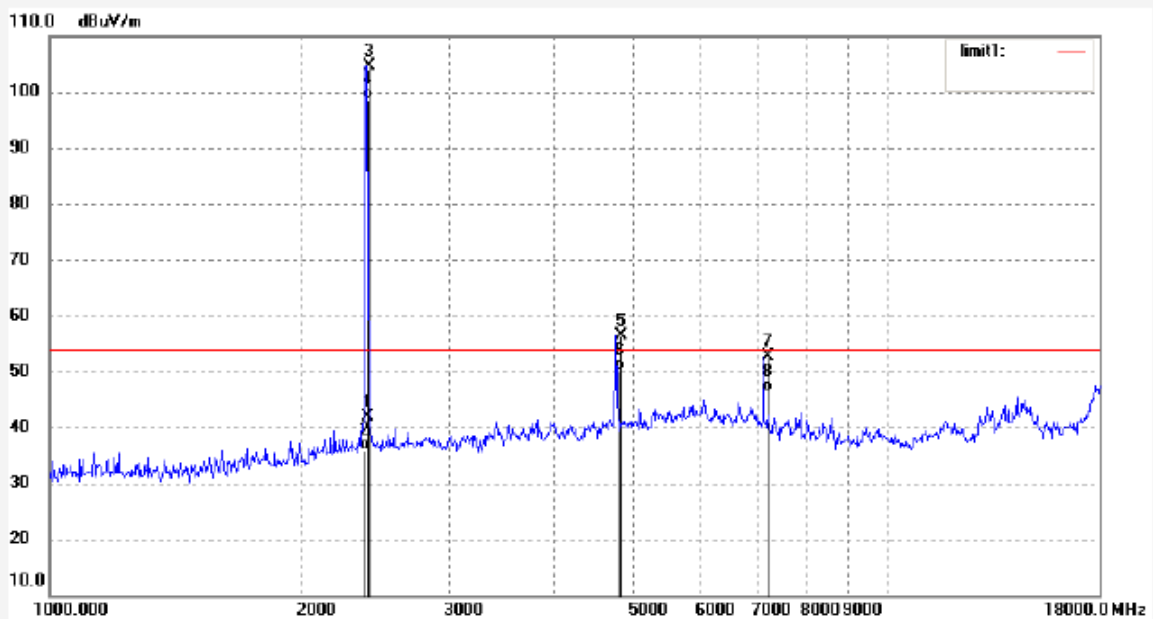

No.	Freq. (MHz)	Reading (dBuV/m)	Factor (dB)	Result (dBuV/m)	Limit (dBuV/m)	Margin (dB)	Detector	Height (cm)	Degree (deg.)	Remark
1	2400.000	49.30	-7.46	41.84	54.00	-12.16	peak			
2	2400.000	43.31	-7.46	35.85	54.00	-18.15	AVG			
3	2412.016	112.17	-7.43	104.74	54.00	50.74	peak			
4	2412.016	106.10	-7.43	98.67	54.00	44.67	AVG			
5	4824.027	56.49	-0.19	56.30	54.00	2.30	peak			
6	4824.027	50.41	-0.19	50.22	54.00	-3.78	AVG			
7	7236.035	49.47	3.05	52.52	54.00	-1.48	peak			
8	7236.035	43.35	3.05	46.40	54.00	-7.60	AVG			



**ACCURATE TECHNOLOGY CO., LTD.**

F1,Bldg,A,Changyuan New Material Port Keyuan Rd,  
Science & Industry Park,Nanshan Shenzhen,P.R.China

Site: 966 chamber  
Tel:+86-0755-26503290  
Fax:+86-0755-26503396

Job No.: RTTE #4586	Polarization: Horizontal
Standard: FCC Class B 3M Radiated	Power Source: AC 120V/60Hz
Test item: Radiation Test	Date: 2010/04/17
Temp.( C)/Hum.(%) 25 C / 50 %	Time: 9:38:32
EUT: GuruPlug	Engineer Signature: Joe
Mode: TX Channal 1(802.11b)	Distance: 3m
Model: 003-GP11A101	
Manufacturer: Globalscale Technologies INC	

Note: Sample No.:100743 Report No.:ATE20100630

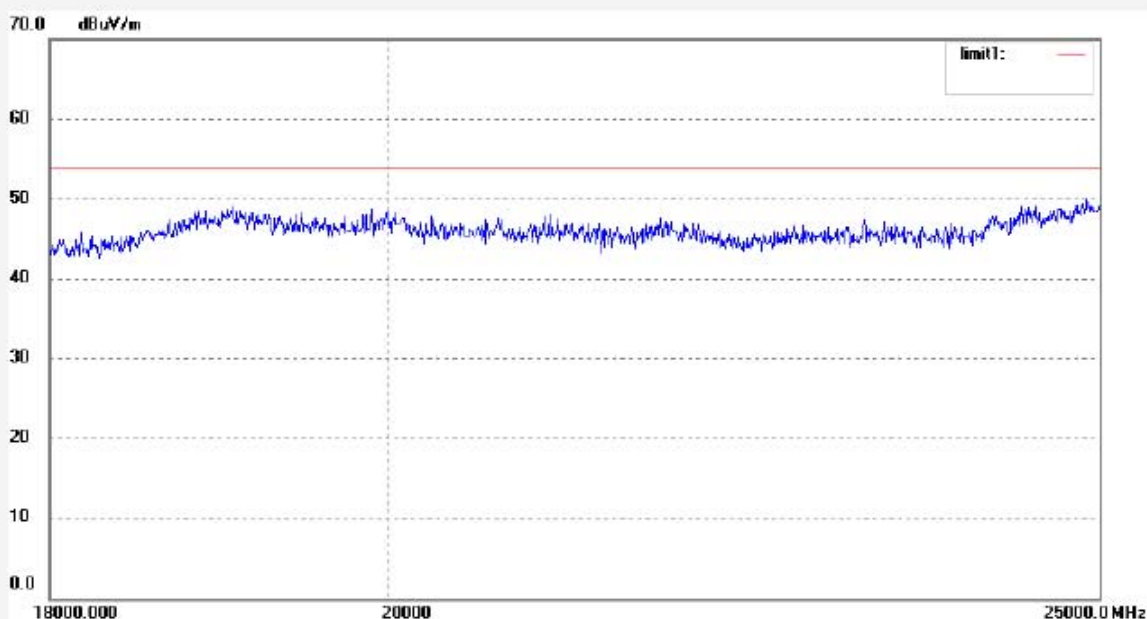

No.	Freq. (MHz)	Reading (dBuV/m)	Factor (dB)	Result (dBuV/m)	Limit (dBuV/m)	Margin (dB)	Detector	Height (cm)	Degree (deg.)	Remark
-----	-------------	------------------	-------------	-----------------	----------------	-------------	----------	-------------	---------------	--------



**ACCURATE TECHNOLOGY CO., LTD.**

F1,Bldg,A,Changyuan New Material Port Keyuan Rd,  
Science & Industry Park,Nanshan Shenzhen,P.R.China

Site: 966 chamber  
Tel:+86-0755-26503290  
Fax:+86-0755-26503396

Job No.: RTTE #4587

Standard: FCC Class B 3M Radiated

Test item: Radiation Test

Temp.( C)/Hum.(%) 25 C / 50 %

EUT: GuruPlug

Mode: TX Channal 1(802.11b)

Model: 003-GP11A101

Manufacturer: Globalscale Technologies INC

Polarization: Vertical

Power Source: AC 120V/60Hz

Date: 2010/04/17

Time: 9:42:24

Engineer Signature: Joe

Distance: 3m

Note: Sample No.:100743 Report No.:ATE20100630

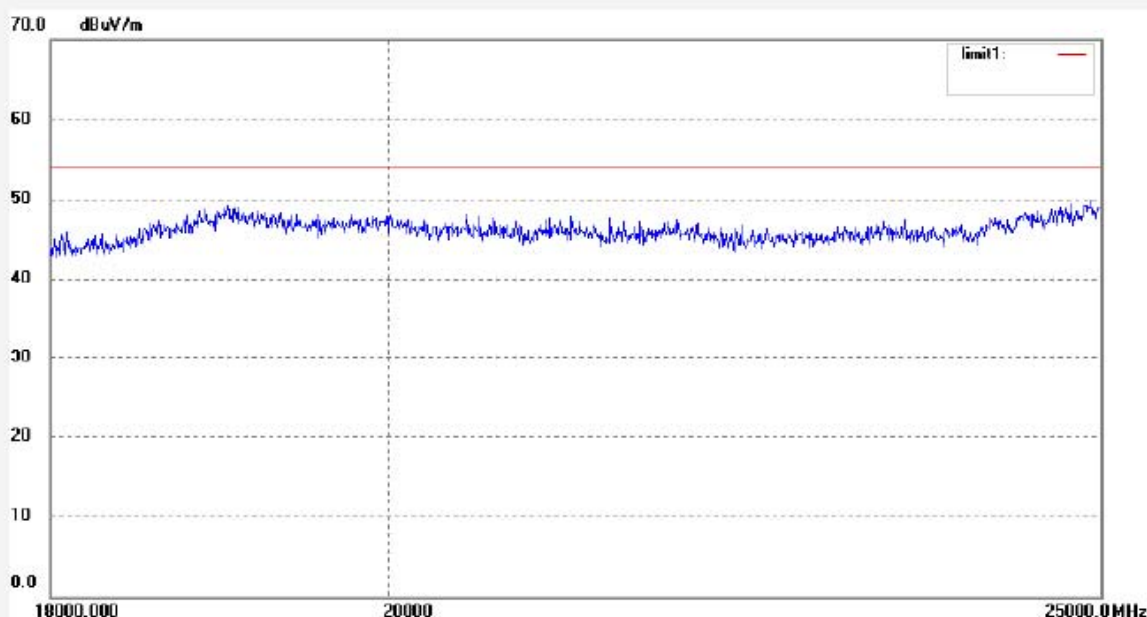

No.	Freq. (MHz)	Reading (dBuV/m)	Factor (dB)	Result (dBuV/m)	Limit (dBuV/m)	Margin (dB)	Detector	Height (cm)	Degree (deg.)	Remark
-----	-------------	------------------	-------------	-----------------	----------------	-------------	----------	-------------	---------------	--------



**ACCURATE TECHNOLOGY CO., LTD.**

F1,Bldg,A,Changyuan New Material Port Keyuan Rd,  
Science & Industry Park,Nanshan Shenzhen,P.R.China

Site: 966 chamber  
Tel:+86-0755-26503290  
Fax:+86-0755-26503396

Job No.: RTTE #4565	Polarization: Horizontal
Standard: FCC Class B 3M Radiated	Power Source: AC 120V/60Hz
Test item: Radiation Test	Date: 2010/04/16
Temp.( C)/Hum.(%) 25 C / 50 %	Time: 11:10:07
EUT: GuruPlug	Engineer Signature: Joe
Mode: TX Channal 6(802.11b)	Distance: 3m
Model: 003-GP11A101	
Manufacturer: Globalscale Technologies INC	

Note: Sample No.:100743 Report No.:ATE20100630

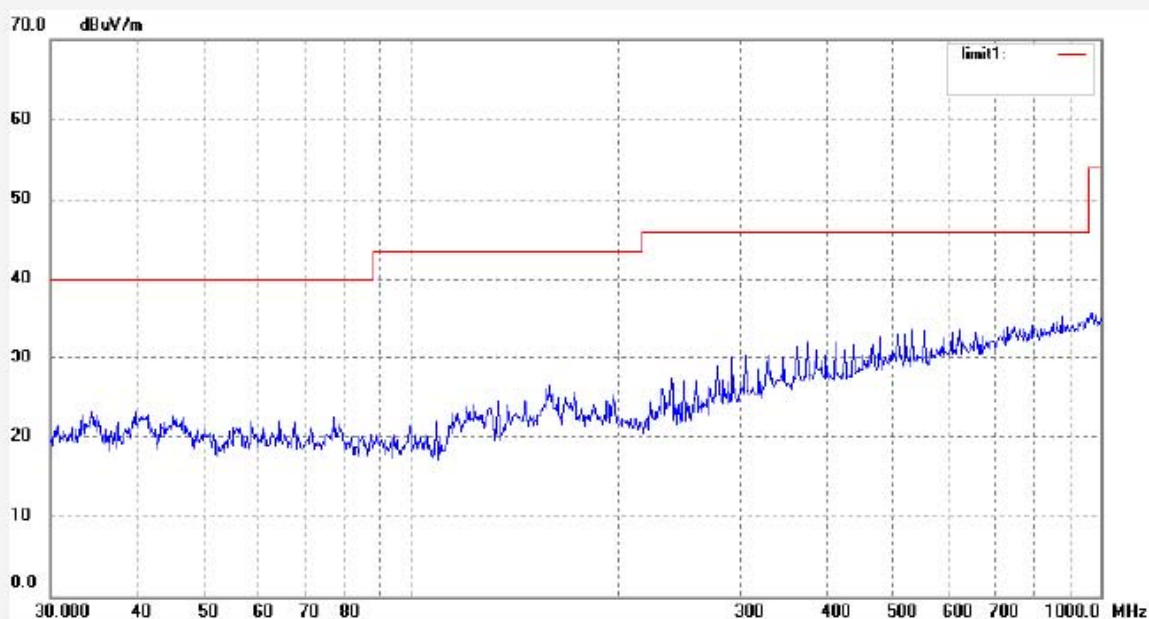

No.	Freq. (MHz)	Reading (dBuV/m)	Factor (dB)	Result (dBuV/m)	Limit (dBuV/m)	Margin (dB)	Detector	Height (cm)	Degree (deg.)	Remark
-----	-------------	------------------	-------------	-----------------	----------------	-------------	----------	-------------	---------------	--------





**ACCURATE TECHNOLOGY CO., LTD.**

F1,Bldg,A,Changyuan New Material Port Keyuan Rd,  
Science & Industry Park,Nanshan Shenzhen,P.R.China

Site: 966 chamber  
Tel:+86-0755-26503290  
Fax:+86-0755-26503396

Job No.: RTTE #4564	Polarization: Vertical
Standard: FCC Class B 3M Radiated	Power Source: AC 120V/60Hz
Test item: Radiation Test	Date: 2010/04/16
Temp.( C)/Hum.(%) 25 C / 50 %	Time: 11:06:23
EUT: GuruPlug	Engineer Signature: Joe
Mode: TX Channal 6(802.11b)	Distance: 3m
Model: 003-GP11A101	
Manufacturer: Globalscale Technologies INC	

Note: Sample No.:100743 Report No.:ATE20100630

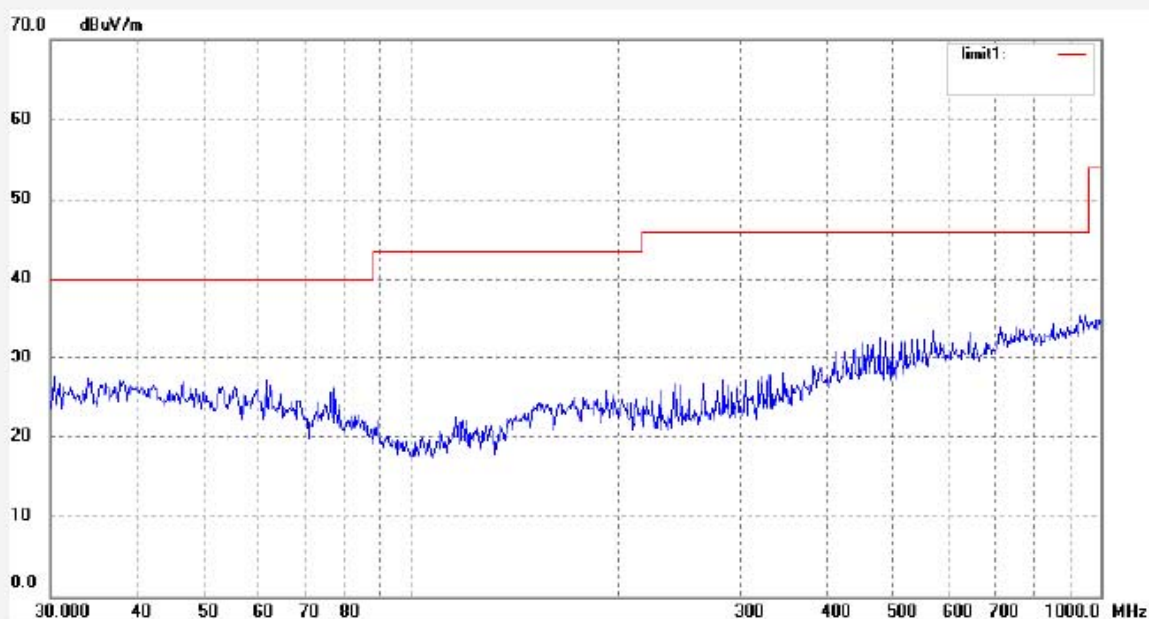

No.	Freq. (MHz)	Reading (dBuV/m)	Factor (dB)	Result (dBuV/m)	Limit (dBuV/m)	Margin (dB)	Detector	Height (cm)	Degree (deg.)	Remark
-----	-------------	------------------	-------------	-----------------	----------------	-------------	----------	-------------	---------------	--------



**ACCURATE TECHNOLOGY CO., LTD.**

F1,Bldg,A,Changyuan New Material Port Keyuan Rd,  
Science & Industry Park,Nanshan Shenzhen,P.R.China

Site: 966 chamber  
Tel:+86-0755-26503290  
Fax:+86-0755-26503396

Job No.: RTTE #4577	Polarization: Horizontal
Standard: FCC Class B 3M Radiated	Power Source: AC 120V/60Hz
Test item: Radiation Test	Date: 2010/04/17
Temp.( C)/Hum.(%) 25 C / 50 %	Time: 8:54:35
EUT: GuruPlug	Engineer Signature: Joe
Mode: TX Channal 6(802.11b)	Distance: 3m
Model: 003-GP11A101	
Manufacturer: Globalscale Technologies INC	

Note: Sample No.:100743 Report No.:ATE20100630

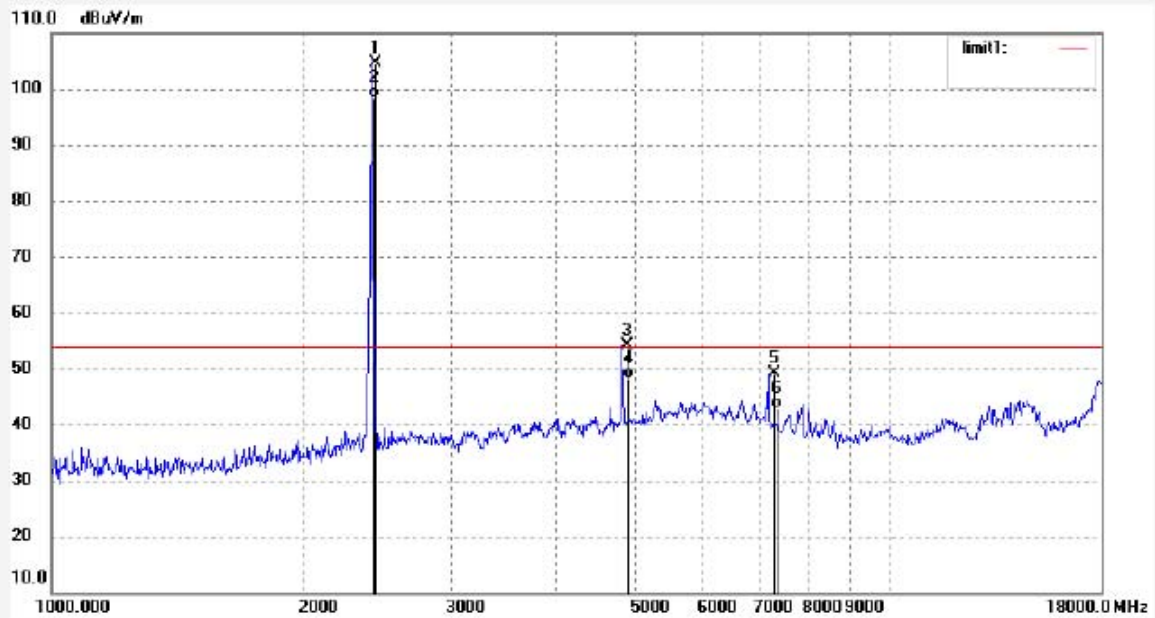

No.	Freq. (MHz)	Reading (dBuV/m)	Factor (dB)	Result (dBuV/m)	Limit (dBuV/m)	Margin (dB)	Detector	Height (cm)	Degree (deg.)	Remark
1	2437.015	111.88	-7.36	104.52	54.00	50.52	peak			
2	2437.015	105.81	-7.36	98.45	54.00	44.45	AVG			
3	4874.027	54.02	0.09	54.11	54.00	0.11	peak			
4	4874.027	47.94	0.09	48.03	54.00	-5.97	AVG			
5	7311.034	45.79	3.22	49.01	54.00	-4.99	peak			
6	7311.034	39.77	3.22	42.99	54.00	-11.01	AVG			



**ACCURATE TECHNOLOGY CO., LTD.**

F1,Bldg,A,Changyuan New Material Port Keyuan Rd,  
Science & Industry Park,Nanshan Shenzhen,P.R.China

Site: 966 chamber  
Tel:+86-0755-26503290  
Fax:+86-0755-26503396

Job No.: RTTE #4576	Polarization: Vertical
Standard: FCC Class B 3M Radiated	Power Source: AC 120V/60Hz
Test item: Radiation Test	Date: 2010/04/17
Temp.( C)/Hum.(%) 25 C / 50 %	Time: 8:50:28
EUT: GuruPlug	Engineer Signature: Joe
Mode: TX Channal 6(802.11b)	Distance: 3m
Model: 003-GP11A101	
Manufacturer: Globalscale Technologies INC	

Note: Sample No.:100743 Report No.:ATE20100630

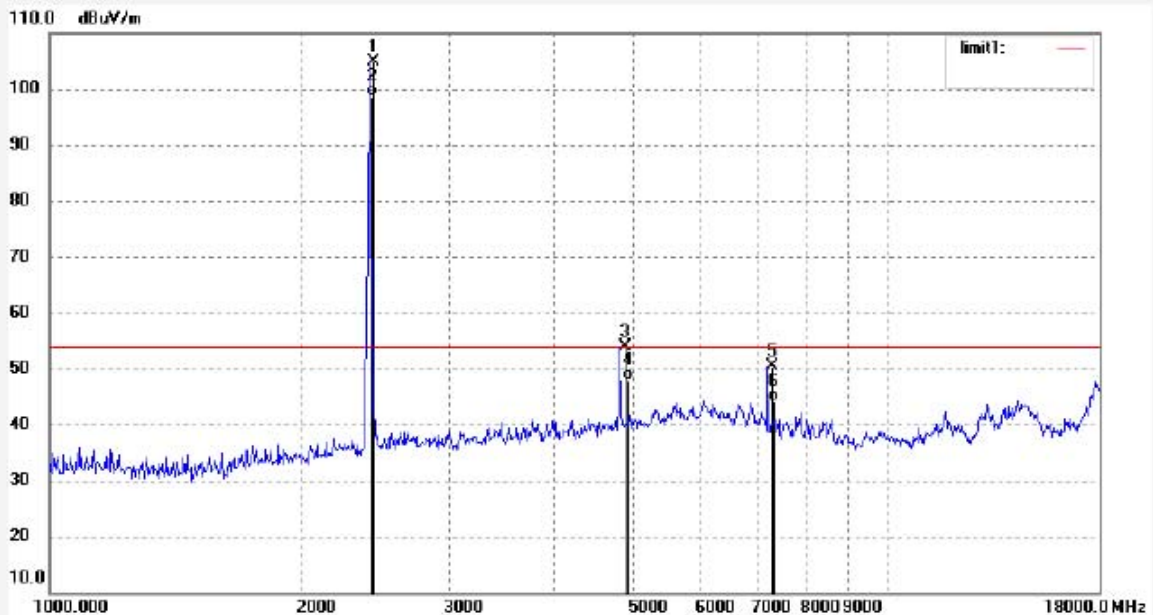

No.	Freq. (MHz)	Reading (dBuV/m)	Factor (dB)	Result (dBuV/m)	Limit (dBuV/m)	Margin (dB)	Detector	Height (cm)	Degree (deg.)	Remark
1	2437.015	112.22	-7.36	104.86	54.00	50.86	peak			
2	2437.015	106.09	-7.36	98.73	54.00	44.73	AVG			
3	4874.027	53.89	0.09	53.98	54.00	-0.02	peak			
4	4874.027	47.84	0.09	47.93	54.00	-6.07	AVG			
5	7311.034	47.14	3.22	50.36	54.00	-3.64	peak			
6	7311.034	41.02	3.22	44.24	54.00	-9.76	AVG			



**ACCURATE TECHNOLOGY CO., LTD.**

F1,Bldg,A,Changyuan New Material Port Keyuan Rd,  
Science & Industry Park,Nanshan Shenzhen,P.R.China

Site: 966 chamber  
Tel:+86-0755-26503290  
Fax:+86-0755-26503396

Job No.: RTTE #4589	Polarization: Horizontal
Standard: FCC Class B 3M Radiated	Power Source: AC 120V/60Hz
Test item: Radiation Test	Date: 2010/04/17
Temp.( C)/Hum.(%) 25 C / 50 %	Time: 9:50:50
EUT: GuruPlug	Engineer Signature: Joe
Mode: TX Channal 6(802.11b)	Distance: 3m
Model: 003-GP11A101	
Manufacturer: Globalscale Technologies INC	

Note: Sample No.:100743 Report No.:ATE20100630

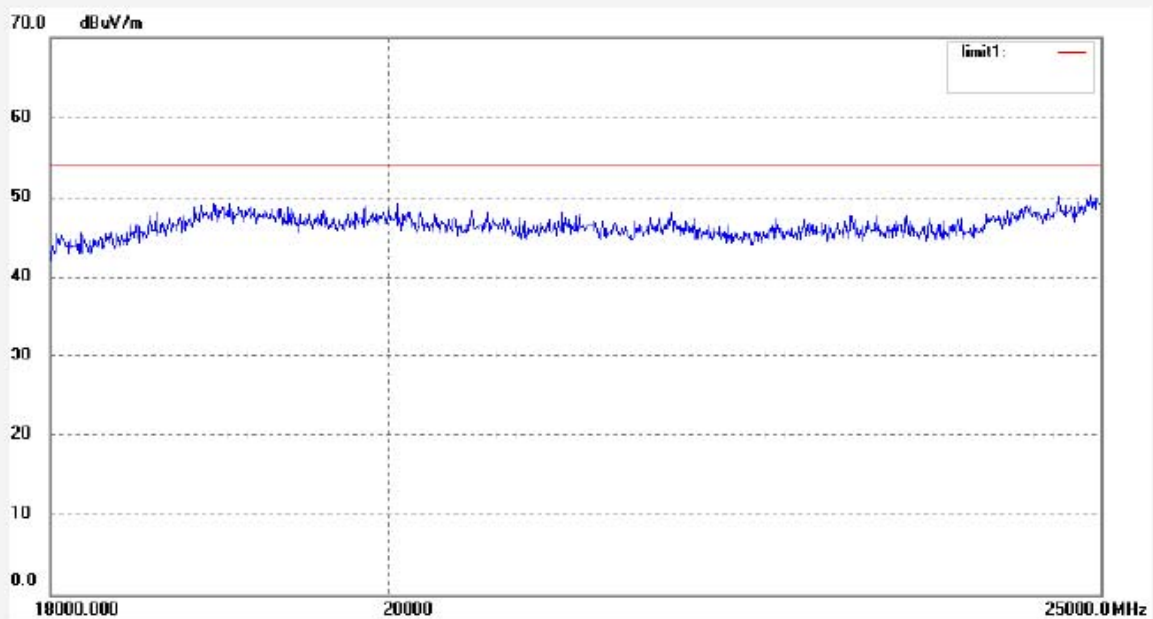

No.	Freq. (MHz)	Reading (dBuV/m)	Factor (dB)	Result (dBuV/m)	Limit (dBuV/m)	Margin (dB)	Detector	Height (cm)	Degree (deg.)	Remark
-----	-------------	------------------	-------------	-----------------	----------------	-------------	----------	-------------	---------------	--------



**ACCURATE TECHNOLOGY CO., LTD.**

F1,Bldg,A,Changyuan New Material Port Keyuan Rd,  
Science & Industry Park,Nanshan Shenzhen,P.R.China

Site: 966 chamber  
Tel:+86-0755-26503290  
Fax:+86-0755-26503396

Job No.: RTTE #4588	Polarization: Vertical
Standard: FCC Class B 3M Radiated	Power Source: AC 120V/60Hz
Test item: Radiation Test	Date: 2010/04/17
Temp.( C)/Hum.(%) 25 C / 50 %	Time: 9:46:56
EUT: GuruPlug	Engineer Signature: Joe
Mode: TX Channal 6(802.11b)	Distance: 3m
Model: 003-GP11A101	
Manufacturer: Globalscale Technologies INC	

Note: Sample No.:100743 Report No.:ATE20100630

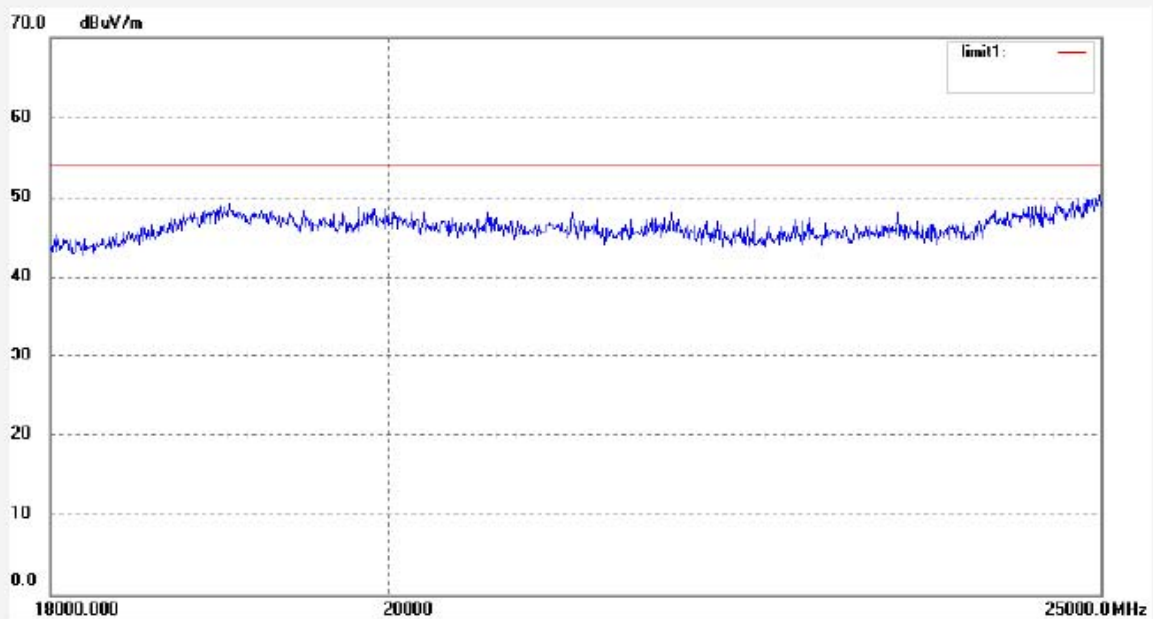

No.	Freq. (MHz)	Reading (dBuV/m)	Factor (dB)	Result (dBuV/m)	Limit (dBuV/m)	Margin (dB)	Detector	Height (cm)	Degree (deg.)	Remark
-----	-------------	------------------	-------------	-----------------	----------------	-------------	----------	-------------	---------------	--------



**ACCURATE TECHNOLOGY CO., LTD.**

F1,Bldg,A,Changyuan New Material Port Keyuan Rd,  
Science & Industry Park,Nanshan Shenzhen,P.R.China

Site: 966 chamber  
Tel:+86-0755-26503290  
Fax:+86-0755-26503396

Job No.: RTTE #4566	Polarization: Horizontal
Standard: FCC Class B 3M Radiated	Power Source: AC 120V/60Hz
Test item: Radiation Test	Date: 2010/04/16
Temp.( C)/Hum.(%) 25 C / 50 %	Time: 11:14:35
EUT: GuruPlug	Engineer Signature: Joe
Mode: TX Channal 11(802.11b)	Distance: 3m
Model: 003-GP11A101	
Manufacturer: Globalscale Technologies INC	

Note: Sample No.:100743 Report No.:ATE20100630

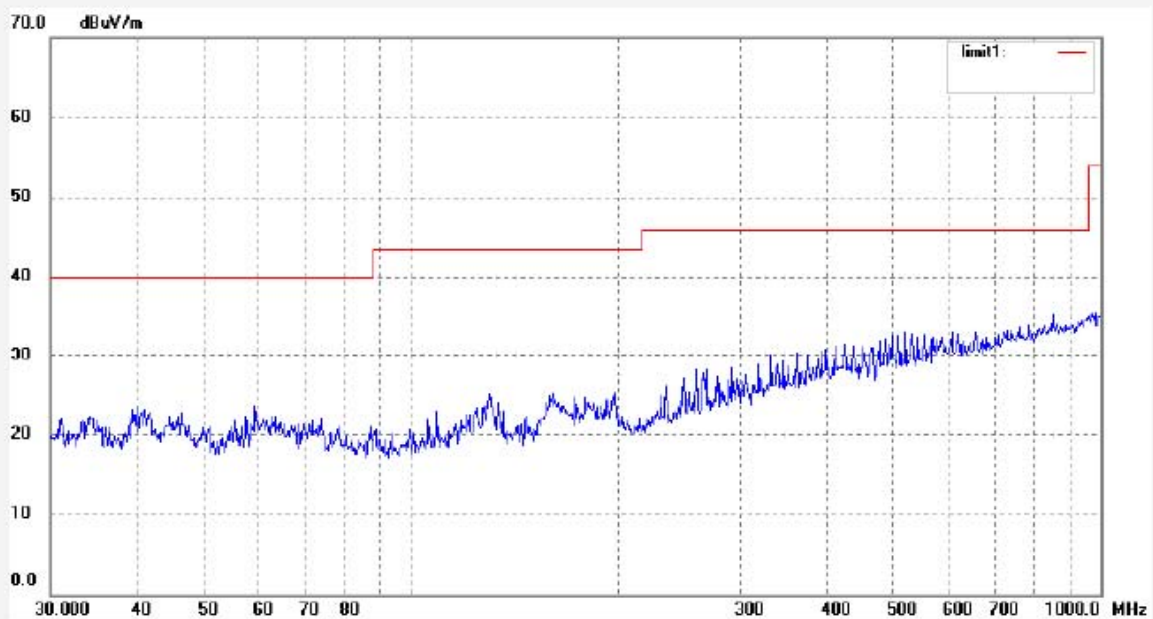

No.	Freq. (MHz)	Reading (dBuV/m)	Factor (dB)	Result (dBuV/m)	Limit (dBuV/m)	Margin (dB)	Detector	Height (cm)	Degree (deg.)	Remark
-----	-------------	------------------	-------------	-----------------	----------------	-------------	----------	-------------	---------------	--------



**ACCURATE TECHNOLOGY CO., LTD.**

F1,Bldg,A,Changyuan New Material Port Keyuan Rd,  
Science & Industry Park,Nanshan Shenzhen,P.R.China

Site: 966 chamber  
Tel:+86-0755-26503290  
Fax:+86-0755-26503396

Job No.: RTTE #4567	Polarization: Vertical
Standard: FCC Class B 3M Radiated	Power Source: AC 120V/60Hz
Test item: Radiation Test	Date: 2010/04/16
Temp.( C)/Hum.(%) 25 C / 50 %	Time: 11:18:12
EUT: GuruPlug	Engineer Signature: Joe
Mode: TX Channal 11(802.11b)	Distance: 3m
Model: 003-GP11A101	
Manufacturer: Globalscale Technologies INC	

Note: Sample No.:100743 Report No.:ATE20100630

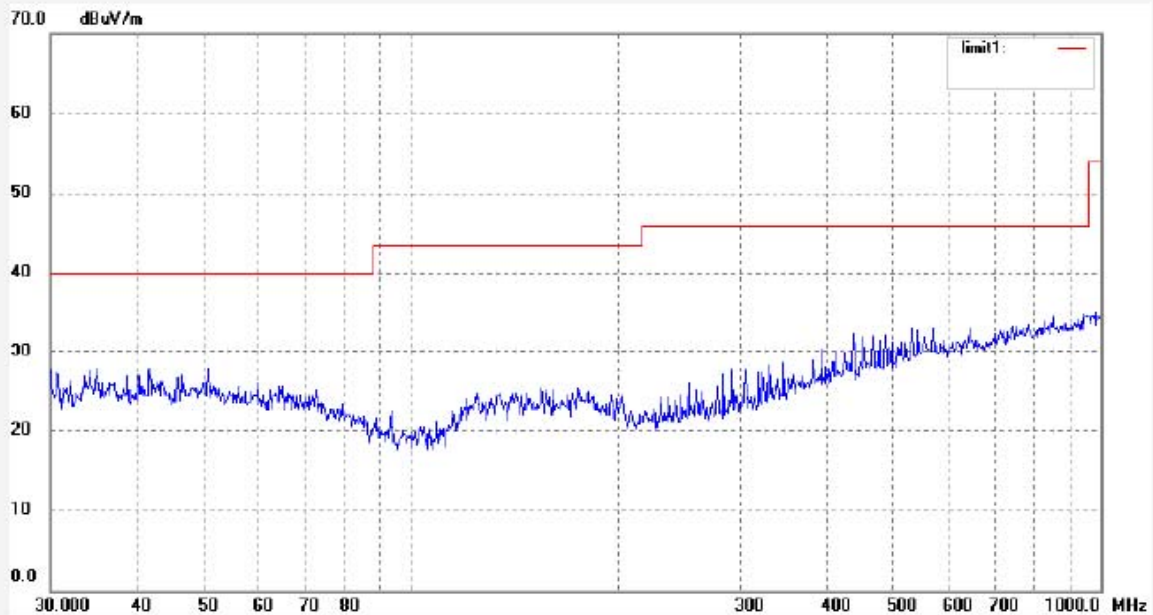

No.	Freq. (MHz)	Reading (dBuV/m)	Factor (dB)	Result (dBuV/m)	Limit (dBuV/m)	Margin (dB)	Detector	Height (cm)	Degree (deg.)	Remark
-----	-------------	------------------	-------------	-----------------	----------------	-------------	----------	-------------	---------------	--------



**ACCURATE TECHNOLOGY CO., LTD.**

F1,Bldg,A,Changyuan New Material Port Keyuan Rd,  
Science & Industry Park,Nanshan Shenzhen,P.R.China

Site: 966 chamber  
Tel:+86-0755-26503290  
Fax:+86-0755-26503396

Job No.: RTTE #4578	Polarization: Horizontal
Standard: FCC Class B 3M Radiated	Power Source: AC 120V/60Hz
Test item: Radiation Test	Date: 2010/04/17
Temp.( C)/Hum.(%) 25 C / 50 %	Time: 8:58:56
EUT: GuruPlug	Engineer Signature: Joe
Mode: TX Channal 11(802.11b)	Distance: 3m
Model: 003-GP11A101	
Manufacturer: Globalscale Technologies INC	

Note: Sample No.:100743 Report No.:ATE20100630

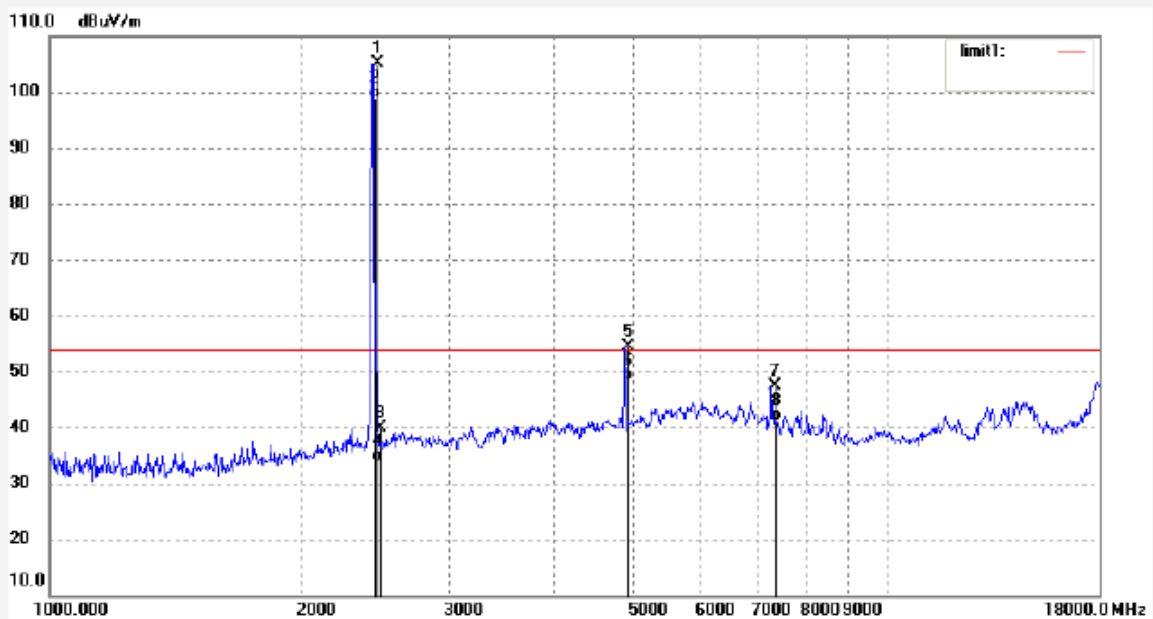

No.	Freq. (MHz)	Reading (dBuV/m)	Factor (dB)	Result (dBuV/m)	Limit (dBuV/m)	Margin (dB)	Detector	Height (cm)	Degree (deg.)	Remark
1	2462.016	112.43	-7.35	105.08	54.00	51.08	peak			
2	2462.016	106.30	-7.35	98.95	54.00	44.95	AVG			
3	2483.500	47.37	-7.37	40.00	54.00	-14.00	peak			
4	2483.500	41.33	-7.37	33.96	54.00	-20.04	AVG			
5	4924.026	54.01	0.34	54.35	54.00	0.35	peak			
6	4924.026	47.95	0.34	48.29	54.00	-5.71	AVG			
7	7386.035	43.88	3.39	47.27	54.00	-6.73	peak			
8	7386.035	37.82	3.39	41.21	54.00	-12.79	AVG			





**ACCURATE TECHNOLOGY CO., LTD.**

F1,Bldg,A,Changyuan New Material Port Keyuan Rd,  
Science & Industry Park,Nanshan Shenzhen,P.R.China

Site: 966 chamber  
Tel:+86-0755-26503290  
Fax:+86-0755-26503396

Job No.: RTTE #4579	Polarization: Vertical
Standard: FCC Class B 3M Radiated	Power Source: AC 120V/60Hz
Test item: Radiation Test	Date: 2010/04/17
Temp.( C)/Hum.(%) 25 C / 50 %	Time: 9:03:07
EUT: GuruPlug	Engineer Signature: Joe
Mode: TX Channal 11(802.11b)	Distance: 3m
Model: 003-GP11A101	
Manufacturer: Globalscale Technologies INC	

Note: Sample No.:100743 Report No.:ATE20100630

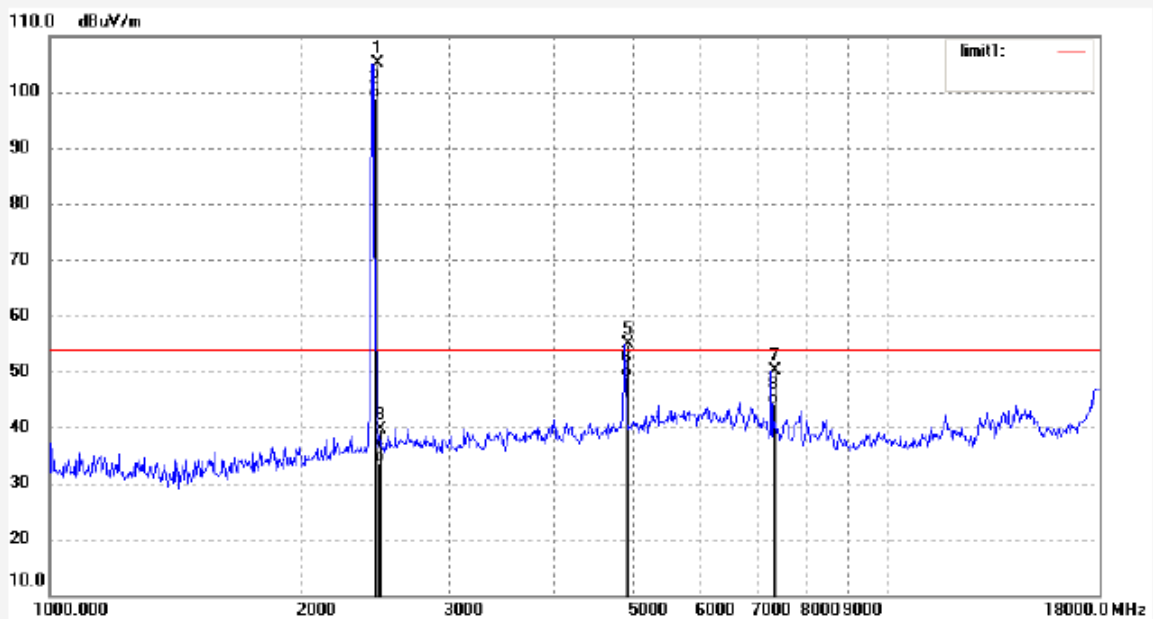

No.	Freq. (MHz)	Reading (dBuV/m)	Factor (dB)	Result (dBuV/m)	Limit (dBuV/m)	Margin (dB)	Detector	Height (cm)	Degree (deg.)	Remark
1	2462.016	112.38	-7.35	105.03	54.00	51.03	peak			
2	2462.016	106.31	-7.35	98.96	54.00	44.96	AVG			
3	2483.500	47.00	-7.37	39.63	54.00	-14.37	peak			
4	2483.500	40.96	-7.37	33.59	54.00	-20.41	AVG			
5	4924.026	54.62	0.34	54.96	54.00	0.96	peak			
6	4924.026	48.49	0.34	48.83	54.00	-5.17	AVG			
7	7386.035	46.79	3.39	50.18	54.00	-3.82	peak			
8	7386.035	40.76	3.39	44.15	54.00	-9.85	AVG			



**ACCURATE TECHNOLOGY CO., LTD.**

F1,Bldg,A,Changyuan New Material Port Keyuan Rd,  
Science & Industry Park,Nanshan Shenzhen,P.R.China

Site: 966 chamber  
Tel:+86-0755-26503290  
Fax:+86-0755-26503396

Job No.: RTTE #4590	Polarization: Horizontal
Standard: FCC Class B 3M Radiated	Power Source: AC 120V/60Hz
Test item: Radiation Test	Date: 2010/04/17
Temp.( C)/Hum.(%) 25 C / 50 %	Time: 9:55:17
EUT: GuruPlug	Engineer Signature: Joe
Mode: TX Channal 11(802.11b)	Distance: 3m
Model: 003-GP11A101	
Manufacturer: Globalscale Technologies INC	

Note: Sample No.:100743 Report No.:ATE20100630

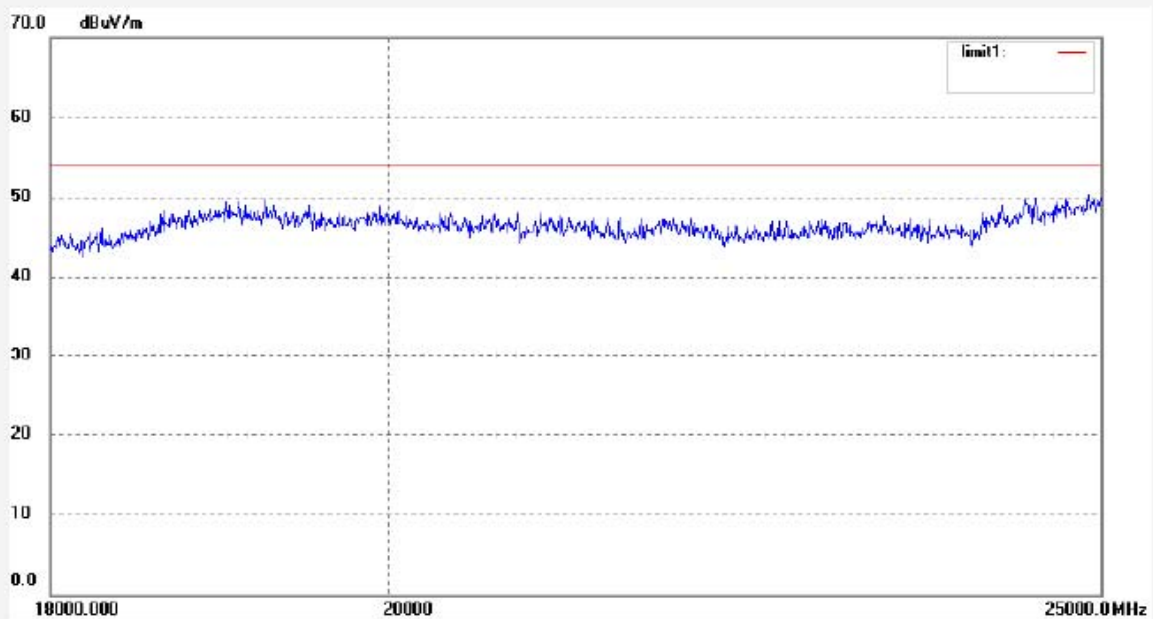

No.	Freq. (MHz)	Reading (dBuV/m)	Factor (dB)	Result (dBuV/m)	Limit (dBuV/m)	Margin (dB)	Detector	Height (cm)	Degree (deg.)	Remark
-----	-------------	------------------	-------------	-----------------	----------------	-------------	----------	-------------	---------------	--------



**ACCURATE TECHNOLOGY CO., LTD.**

F1,Bldg,A,Changyuan New Material Port Keyuan Rd,  
Science & Industry Park,Nanshan Shenzhen,P.R.China

Site: 966 chamber  
Tel:+86-0755-26503290  
Fax:+86-0755-26503396

Job No.: RTTE #4591	Polarization: Vertical
Standard: FCC Class B 3M Radiated	Power Source: AC 120V/60Hz
Test item: Radiation Test	Date: 2010/04/17
Temp.( C)/Hum.(%) 25 C / 50 %	Time: 9:59:09
EUT: GuruPlug	Engineer Signature: Joe
Mode: TX Channal 11(802.11b)	Distance: 3m
Model: 003-GP11A101	
Manufacturer: Globalscale Technologies INC	

Note: Sample No.:100743 Report No.:ATE20100630

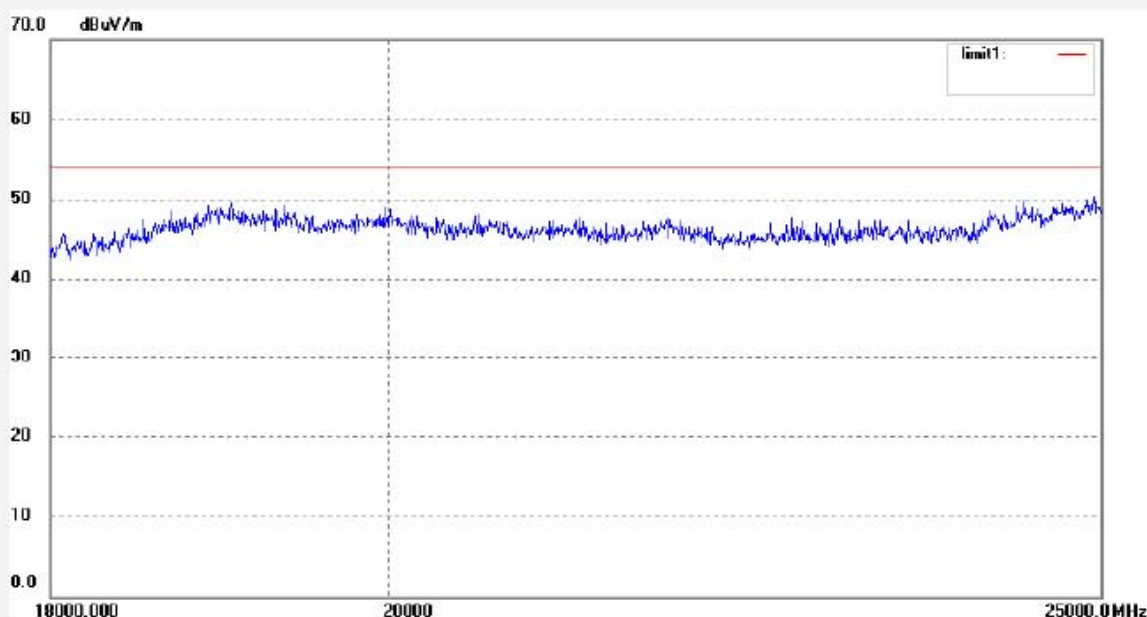

No.	Freq. (MHz)	Reading (dBuV/m)	Factor (dB)	Result (dBuV/m)	Limit (dBuV/m)	Margin (dB)	Detector	Height (cm)	Degree (deg.)	Remark
-----	-------------	------------------	-------------	-----------------	----------------	-------------	----------	-------------	---------------	--------



**ACCURATE TECHNOLOGY CO., LTD.**

F1,Bldg,A,Changyuan New Material Port Keyuan Rd,  
Science & Industry Park,Nanshan Shenzhen,P.R.China

Site: 966 chamber  
Tel:+86-0755-26503290  
Fax:+86-0755-26503396

Job No.: RTTE #4569	Polarization: Horizontal
Standard: FCC Class B 3M Radiated	Power Source: AC 120V/60Hz
Test item: Radiation Test	Date: 2010/04/16
Temp.( C)/Hum.(%) 25 C / 50 %	Time: 11:29:57
EUT: GuruPlug	Engineer Signature: Joe
Mode: TX Channal 1(802.11g)	Distance: 3m
Model: 003-GP11A101	
Manufacturer: Globalscale Technologies INC	

Note: Sample No.:100743 Report No.:ATE20100630

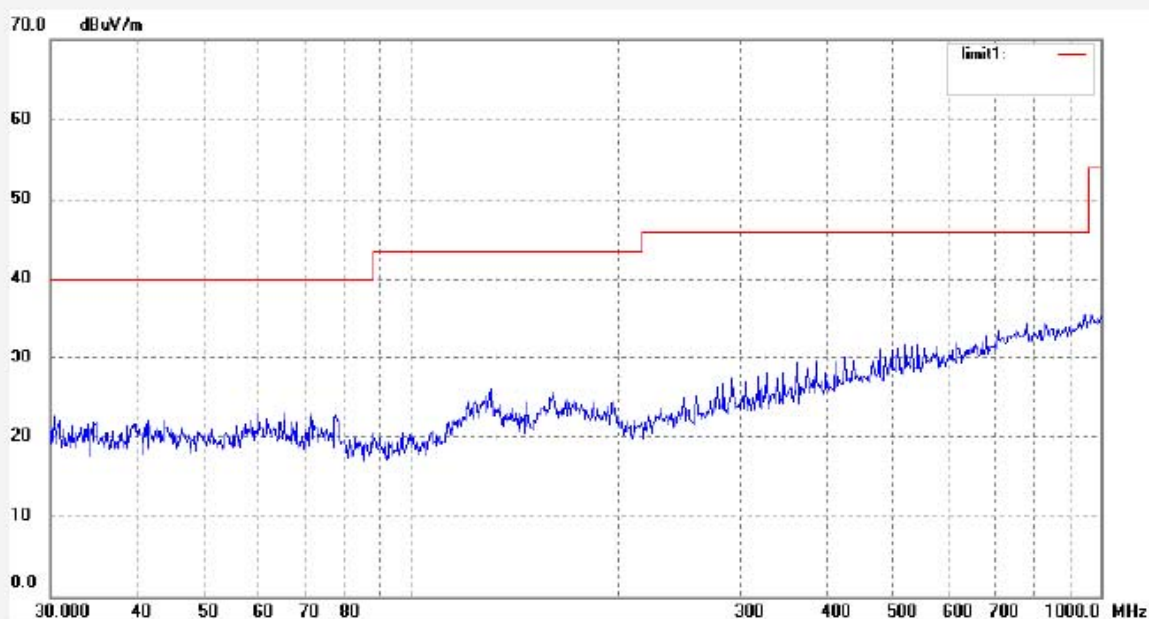

No.	Freq. (MHz)	Reading (dBuV/m)	Factor (dB)	Result (dBuV/m)	Limit (dBuV/m)	Margin (dB)	Detector	Height (cm)	Degree (deg.)	Remark
-----	-------------	------------------	-------------	-----------------	----------------	-------------	----------	-------------	---------------	--------



**ACCURATE TECHNOLOGY CO., LTD.**

F1,Bldg,A,Changyuan New Material Port Keyuan Rd,  
Science & Industry Park,Nanshan Shenzhen,P.R.China

Site: 966 chamber  
Tel:+86-0755-26503290  
Fax:+86-0755-26503396

Job No.: RTTE #4568	Polarization: Vertical
Standard: FCC Class B 3M Radiated	Power Source: AC 120V/60Hz
Test item: Radiation Test	Date: 2010/04/16
Temp.( C)/Hum.(%) 25 C / 50 %	Time: 11:26:18
EUT: GuruPlug	Engineer Signature: Joe
Mode: TX Channal 1(802.11g)	Distance: 3m
Model: 003-GP11A101	
Manufacturer: Globalscale Technologies INC	

Note: Sample No.:100743 Report No.:ATE20100630

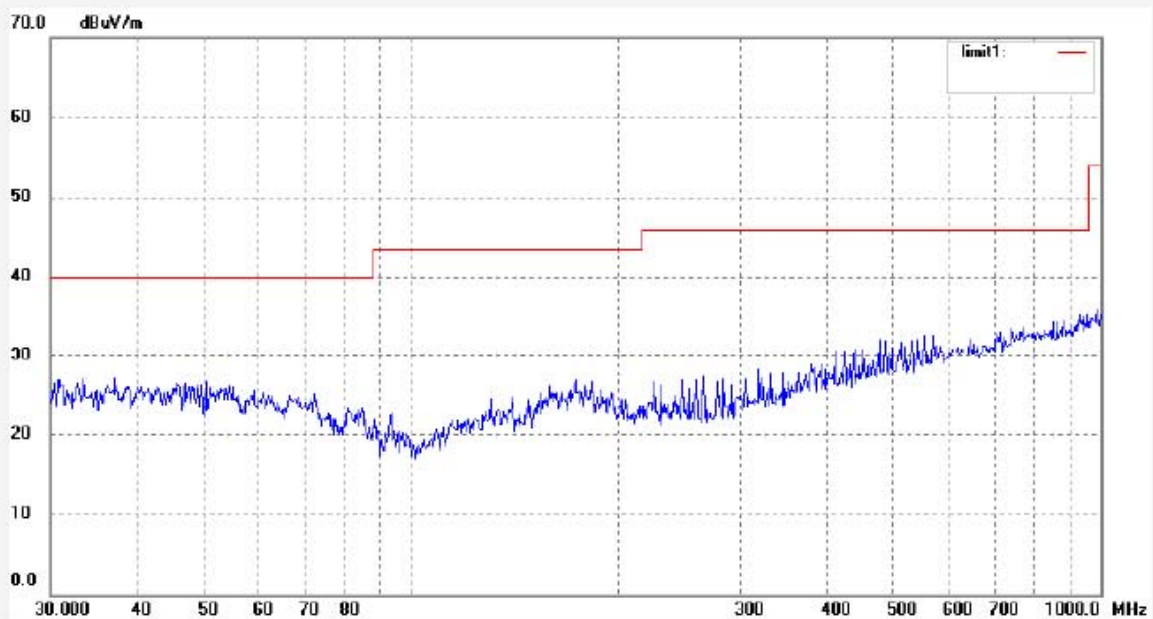

No.	Freq. (MHz)	Reading (dBuV/m)	Factor (dB)	Result (dBuV/m)	Limit (dBuV/m)	Margin (dB)	Detector	Height (cm)	Degree (deg.)	Remark
-----	-------------	------------------	-------------	-----------------	----------------	-------------	----------	-------------	---------------	--------



**ACCURATE TECHNOLOGY CO., LTD.**

F1,Bldg,A,Changyuan New Material Port Keyuan Rd,  
Science & Industry Park,Nanshan Shenzhen,P.R.China

Site: 966 chamber  
Tel:+86-0755-26503290  
Fax:+86-0755-26503396

Job No.: RTTE #4581	Polarization: Horizontal
Standard: FCC Class B 3M Radiated	Power Source: AC 120V/60Hz
Test item: Radiation Test	Date: 2010/04/17
Temp.( C)/Hum.(%) 25 C / 50 %	Time: 9:13:30
EUT: GuruPlug	Engineer Signature: Joe
Mode: TX Channal 1(802.11g)	Distance: 3m
Model: 003-GP11A101	
Manufacturer: Globalscale Technologies INC	

Note: Sample No.:100743 Report No.:ATE20100630

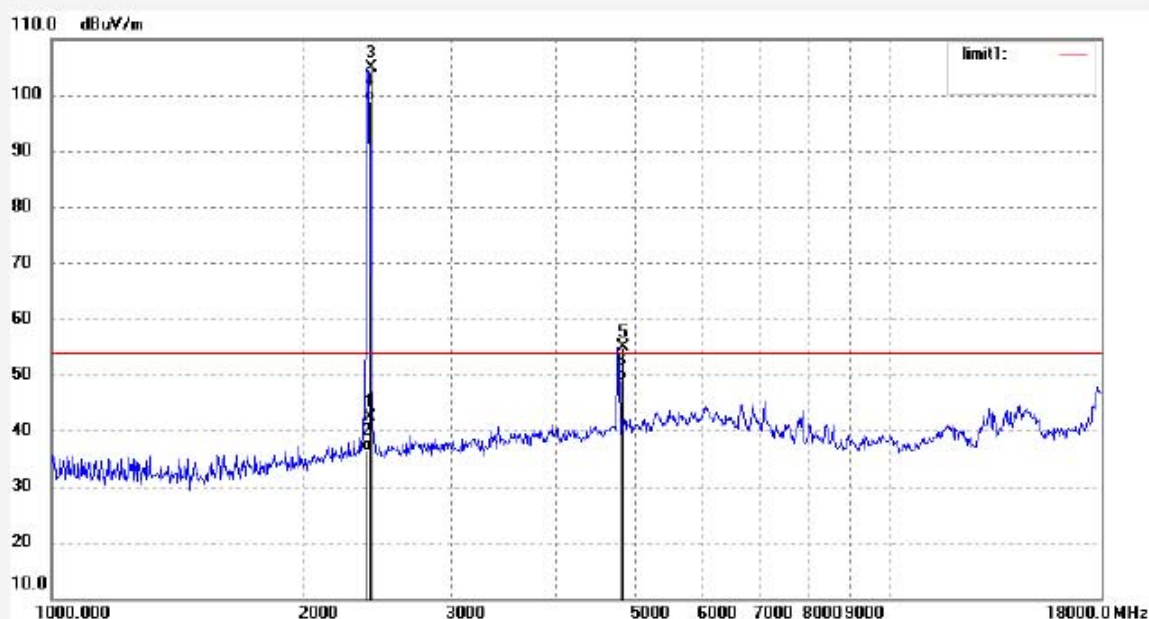

No.	Freq. (MHz)	Reading (dBuV/m)	Factor (dB)	Result (dBuV/m)	Limit (dBuV/m)	Margin (dB)	Detector	Height (cm)	Degree (deg.)	Remark
1	2400.000	49.86	-7.46	42.40	54.00	-11.60	peak			
2	2400.000	43.75	-7.46	36.29	54.00	-17.71	AVG			
3	2412.016	112.41	-7.43	104.98	54.00	50.98	peak			
4	2412.016	106.32	-7.43	98.89	54.00	44.89	AVG			
5	4824.027	55.09	-0.19	54.90	54.00	0.90	peak			
6	4824.027	49.02	-0.19	48.83	54.00	-5.17	AVG			



**ACCURATE TECHNOLOGY CO., LTD.**

F1,Bldg,A,Changyuan New Material Port Keyuan Rd,  
Science & Industry Park,Nanshan Shenzhen,P.R.China

Site: 966 chamber  
Tel:+86-0755-26503290  
Fax:+86-0755-26503396

Job No.: RTTE #4580	Polarization: Vertical
Standard: FCC Class B 3M Radiated	Power Source: AC 120V/60Hz
Test item: Radiation Test	Date: 2010/04/17
Temp.( C)/Hum.(%) 25 C / 50 %	Time: 9:09:21
EUT: GuruPlug	Engineer Signature: Joe
Mode: TX Channal 1(802.11g)	Distance: 3m
Model: 003-GP11A101	
Manufacturer: Globalscale Technologies INC	

Note: Sample No.:100743 Report No.:ATE20100630

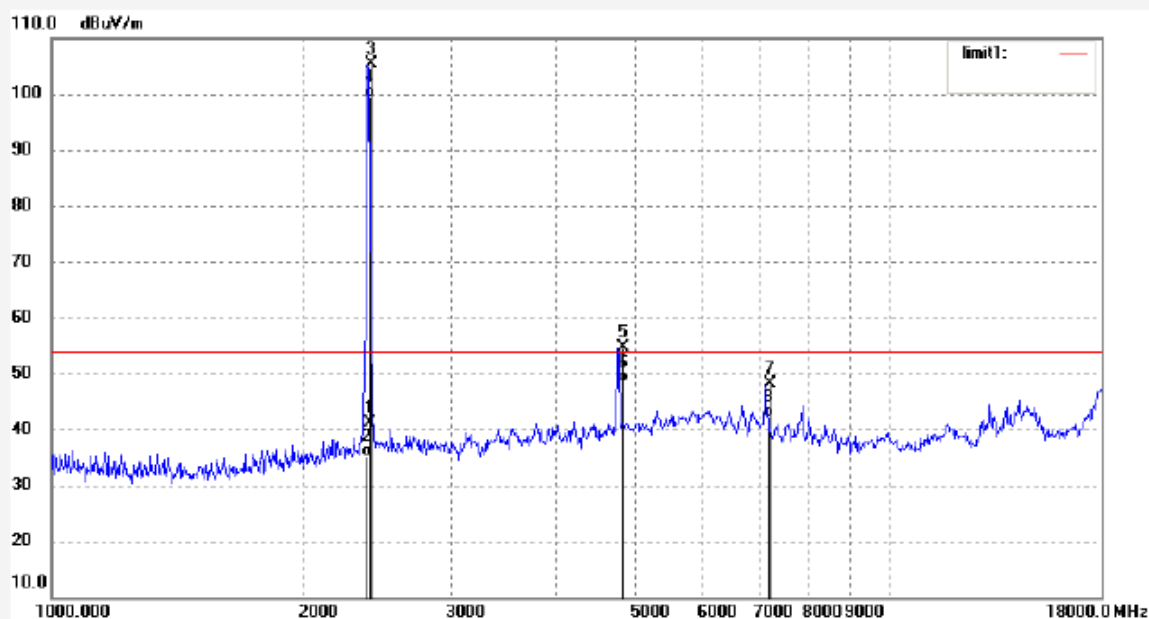

No.	Freq. (MHz)	Reading (dBuV/m)	Factor (dB)	Result (dBuV/m)	Limit (dBuV/m)	Margin (dB)	Detector	Height (cm)	Degree (deg.)	Remark
1	2400.000	48.59	-7.46	41.13	54.00	-12.87	peak			
2	2400.000	42.54	-7.46	35.08	54.00	-18.92	AVG			
3	2412.016	112.89	-7.43	105.46	54.00	51.46	peak			
4	2412.016	106.77	-7.43	99.34	54.00	45.34	AVG			
5	4824.027	54.76	-0.19	54.57	54.00	0.57	peak			
6	4824.027	48.67	-0.19	48.48	54.00	-5.52	AVG			
7	7236.035	45.15	3.05	48.20	54.00	-5.80	peak			
8	7236.035	39.10	3.05	42.15	54.00	-11.85	AVG			



**ACCURATE TECHNOLOGY CO., LTD.**

F1,Bldg,A,Changyuan New Material Port Keyuan Rd,  
Science & Industry Park,Nanshan Shenzhen,P.R.China

Site: 966 chamber  
Tel:+86-0755-26503290  
Fax:+86-0755-26503396

Job No.: RTTE #4593	Polarization: Horizontal
Standard: FCC Class B 3M Radiated	Power Source: AC 120V/60Hz
Test item: Radiation Test	Date: 2010/04/17
Temp.( C)/Hum.(%) 25 C / 50 %	Time: 10:09:33
EUT: GuruPlug	Engineer Signature: Joe
Mode: TX Channal 1(802.11g)	Distance: 3m
Model: 003-GP11A101	
Manufacturer: Globalscale Technologies INC	

Note: Sample No.:100743 Report No.:ATE20100630

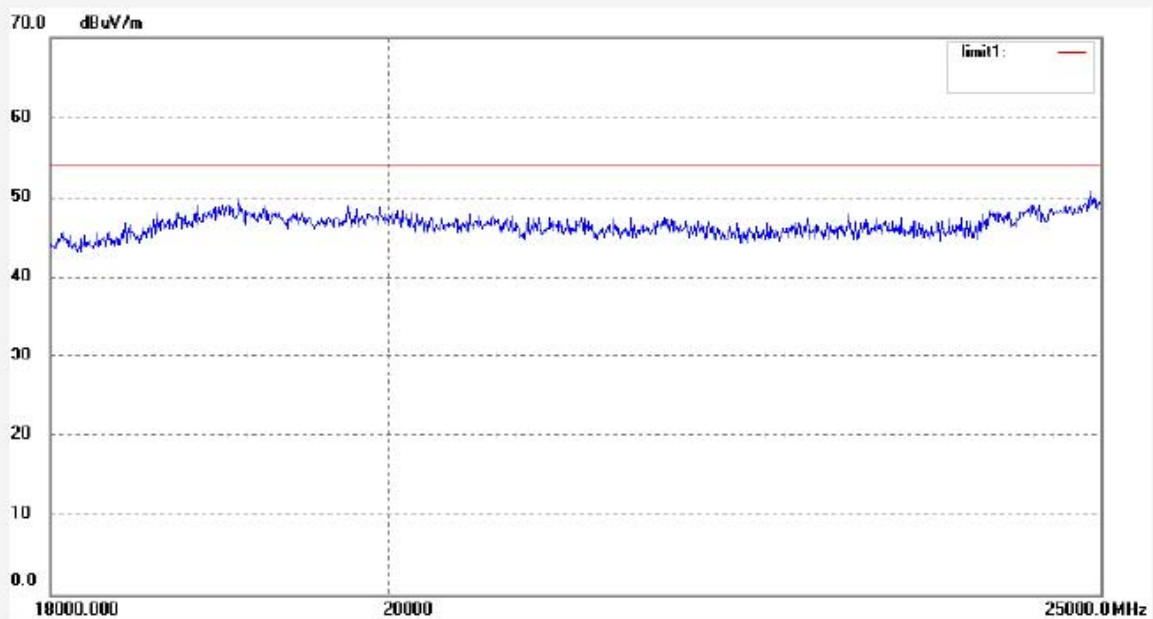

No.	Freq. (MHz)	Reading (dBuV/m)	Factor (dB)	Result (dBuV/m)	Limit (dBuV/m)	Margin (dB)	Detector	Height (cm)	Degree (deg.)	Remark
-----	-------------	------------------	-------------	-----------------	----------------	-------------	----------	-------------	---------------	--------





**ACCURATE TECHNOLOGY CO., LTD.**

F1,Bldg,A,Changyuan New Material Port Keyuan Rd,  
Science & Industry Park,Nanshan Shenzhen,P.R.China

Site: 966 chamber  
Tel:+86-0755-26503290  
Fax:+86-0755-26503396

Job No.: RTTE #4592	Polarization: Vertical
Standard: FCC Class B 3M Radiated	Power Source: AC 120V/60Hz
Test item: Radiation Test	Date: 2010/04/17
Temp.( C)/Hum.(%) 25 C / 50 %	Time: 10:05:41
EUT: GuruPlug	Engineer Signature: Joe
Mode: TX Channal 1(802.11g)	Distance: 3m
Model: 003-GP11A101	
Manufacturer: Globalscale Technologies INC	

Note: Sample No.:100743 Report No.:ATE20100630

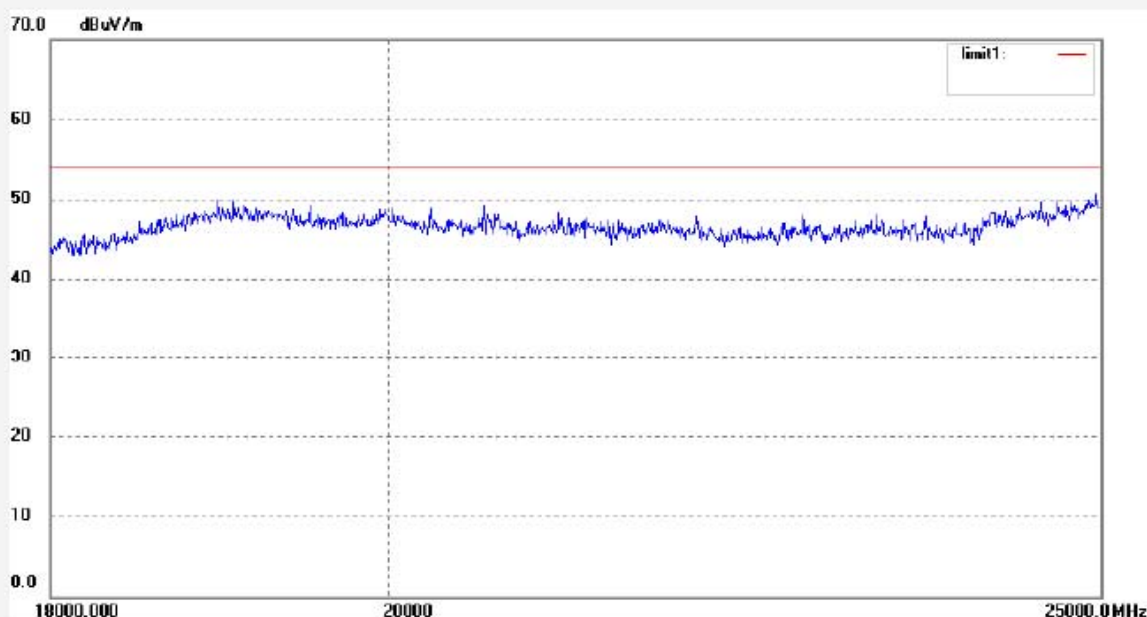

No.	Freq. (MHz)	Reading (dBuV/m)	Factor (dB)	Result (dBuV/m)	Limit (dBuV/m)	Margin (dB)	Detector	Height (cm)	Degree (deg.)	Remark
-----	-------------	------------------	-------------	-----------------	----------------	-------------	----------	-------------	---------------	--------



**ACCURATE TECHNOLOGY CO., LTD.**

F1,Bldg,A,Changyuan New Material Port Keyuan Rd,  
Science & Industry Park,Nanshan Shenzhen,P.R.China

Site: 966 chamber  
Tel:+86-0755-26503290  
Fax:+86-0755-26503396

Job No.: RTTE #4570	Polarization: Horizontal
Standard: FCC Class B 3M Radiated	Power Source: AC 120V/60Hz
Test item: Radiation Test	Date: 2010/04/16
Temp.( C)/Hum.(%) 25 C / 50 %	Time: 11:34:27
EUT: GuruPlug	Engineer Signature: Joe
Mode: TX Channal 6(802.11g)	Distance: 3m
Model: 003-GP11A101	
Manufacturer: Globalscale Technologies INC	

Note: Sample No.:100743 Report No.:ATE20100630

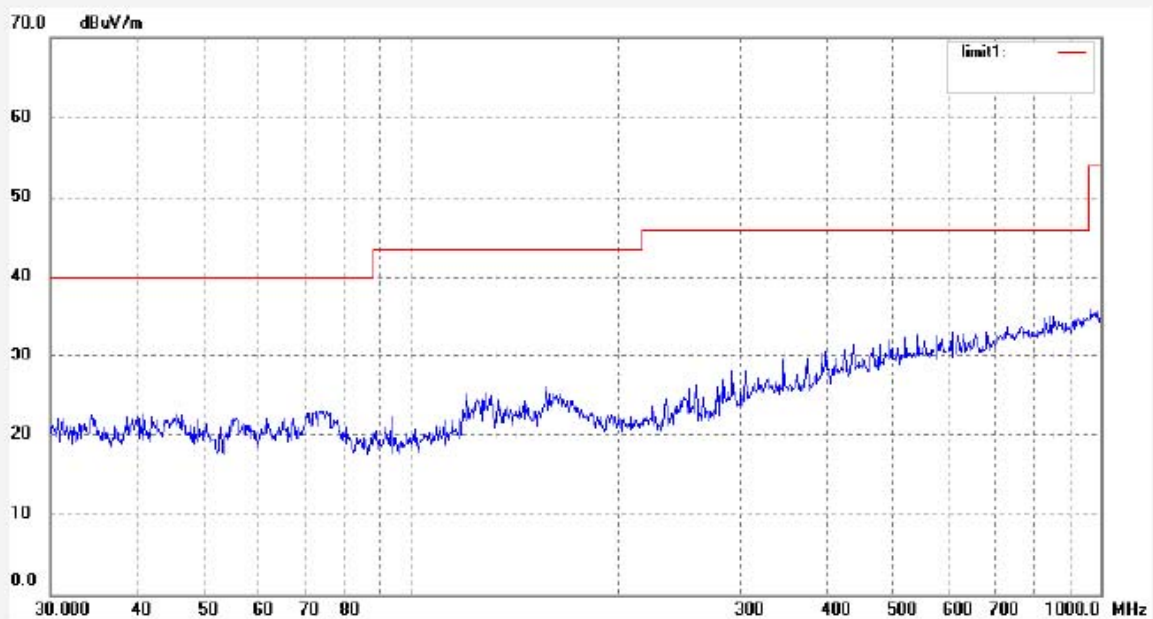

No.	Freq. (MHz)	Reading (dBuV/m)	Factor (dB)	Result (dBuV/m)	Limit (dBuV/m)	Margin (dB)	Detector	Height (cm)	Degree (deg.)	Remark
-----	-------------	------------------	-------------	-----------------	----------------	-------------	----------	-------------	---------------	--------



**ACCURATE TECHNOLOGY CO., LTD.**

F1,Bldg,A,Changyuan New Material Port Keyuan Rd,  
Science & Industry Park,Nanshan Shenzhen,P.R.China

Site: 966 chamber  
Tel:+86-0755-26503290  
Fax:+86-0755-26503396

Job No.: RTTE #4571	Polarization: Vertical
Standard: FCC Class B 3M Radiated	Power Source: AC 120V/60Hz
Test item: Radiation Test	Date: 2010/04/16
Temp.( C)/Hum.(%) 25 C / 50 %	Time: 11:38:09
EUT: GuruPlug	Engineer Signature: Joe
Mode: TX Channal 6(802.11g)	Distance: 3m
Model: 003-GP11A101	
Manufacturer: Globalscale Technologies INC	

Note: Sample No.:100743 Report No.:ATE20100630

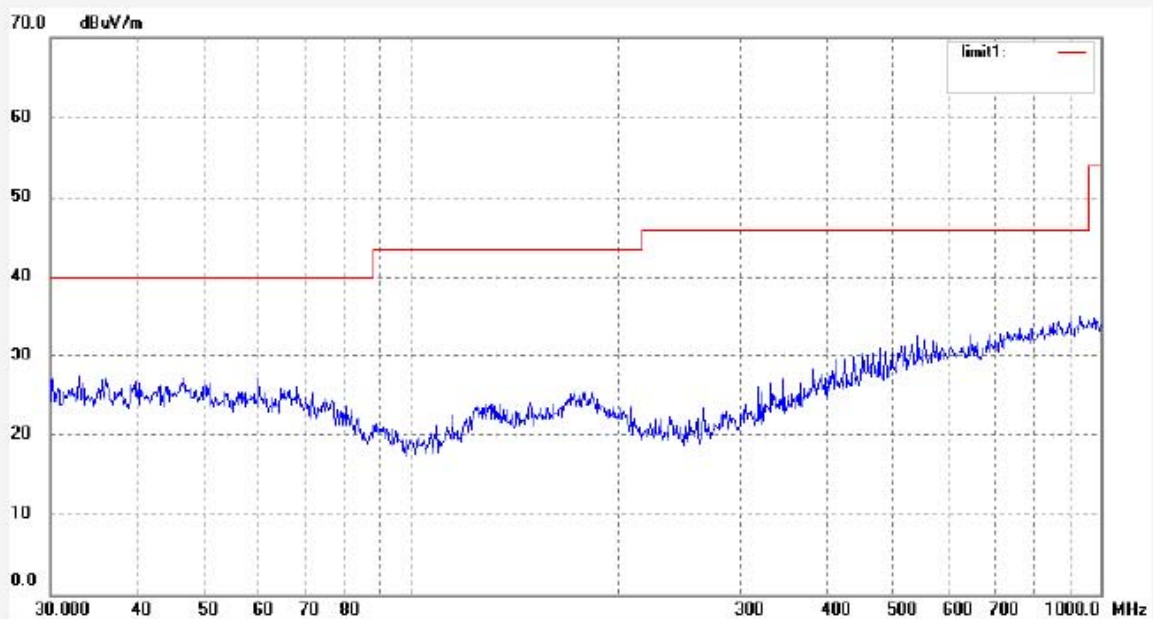

No.	Freq. (MHz)	Reading (dBuV/m)	Factor (dB)	Result (dBuV/m)	Limit (dBuV/m)	Margin (dB)	Detector	Height (cm)	Degree (deg.)	Remark
-----	-------------	------------------	-------------	-----------------	----------------	-------------	----------	-------------	---------------	--------



**ACCURATE TECHNOLOGY CO., LTD.**

F1,Bldg,A,Changyuan New Material Port Keyuan Rd,  
Science & Industry Park,Nanshan Shenzhen,P.R.China

Site: 966 chamber  
Tel:+86-0755-26503290  
Fax:+86-0755-26503396

Job No.: RTTE #4582	Polarization: Horizontal
Standard: FCC Class B 3M Radiated	Power Source: AC 120V/60Hz
Test item: Radiation Test	Date: 2010/04/17
Temp.( C)/Hum.(%) 25 C / 50 %	Time: 9:17:58
EUT: GuruPlug	Engineer Signature: Joe
Mode: TX Channal 6(802.11g)	Distance: 3m
Model: 003-GP11A101	
Manufacturer: Globalscale Technologies INC	

Note: Sample No.:100743 Report No.:ATE20100630

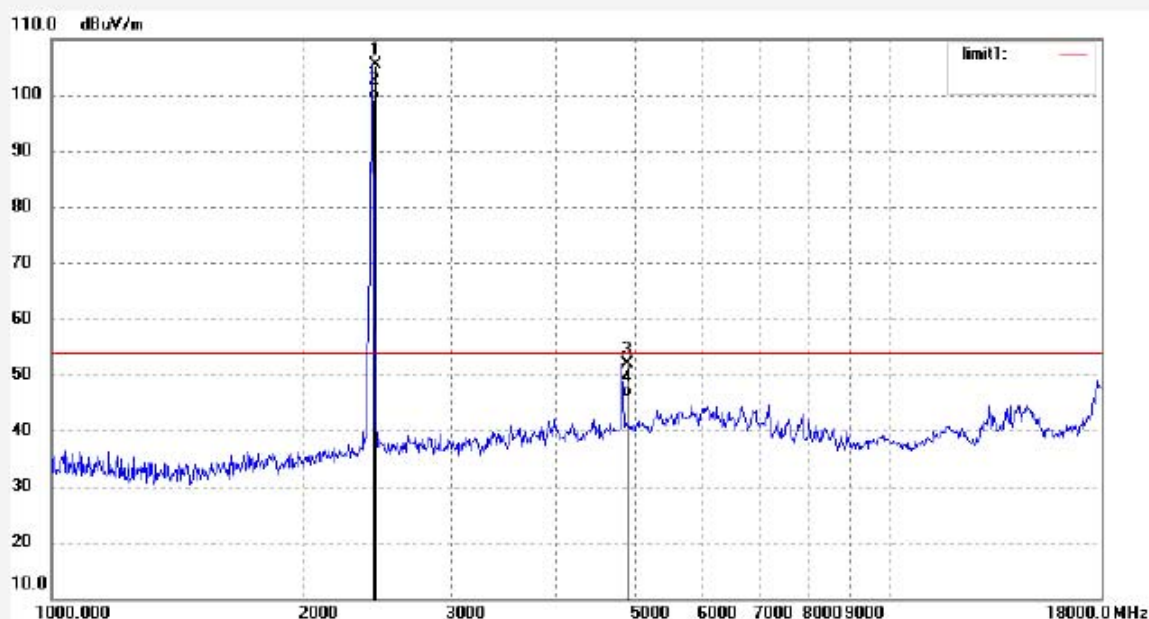

No.	Freq. (MHz)	Reading (dBuV/m)	Factor (dB)	Result (dBuV/m)	Limit (dBuV/m)	Margin (dB)	Detector	Height (cm)	Degree (deg.)	Remark
1	2437.015	112.74	-7.36	105.38	54.00	51.38	peak			
2	2437.015	106.58	-7.36	99.22	54.00	45.22	AVG			
3	4874.027	51.82	0.09	51.91	54.00	-2.09	peak			
4	4874.027	45.69	0.09	45.78	54.00	-8.22	AVG			



**ACCURATE TECHNOLOGY CO., LTD.**

F1,Bldg,A,Changyuan New Material Port Keyuan Rd,  
Science & Industry Park,Nanshan Shenzhen,P.R.China

Site: 966 chamber  
Tel:+86-0755-26503290  
Fax:+86-0755-26503396

Job No.: RTTE #4583	Polarization: Vertical
Standard: FCC Class B 3M Radiated	Power Source: AC 120V/60Hz
Test item: Radiation Test	Date: 2010/04/17
Temp.( C)/Hum.(%) 25 C / 50 %	Time: 9:22:11
EUT: GuruPlug	Engineer Signature: Joe
Mode: TX Channal 6(802.11g)	Distance: 3m
Model: 003-GP11A101	
Manufacturer: Globalscale Technologies INC	

Note: Sample No.:100743 Report No.:ATE20100630

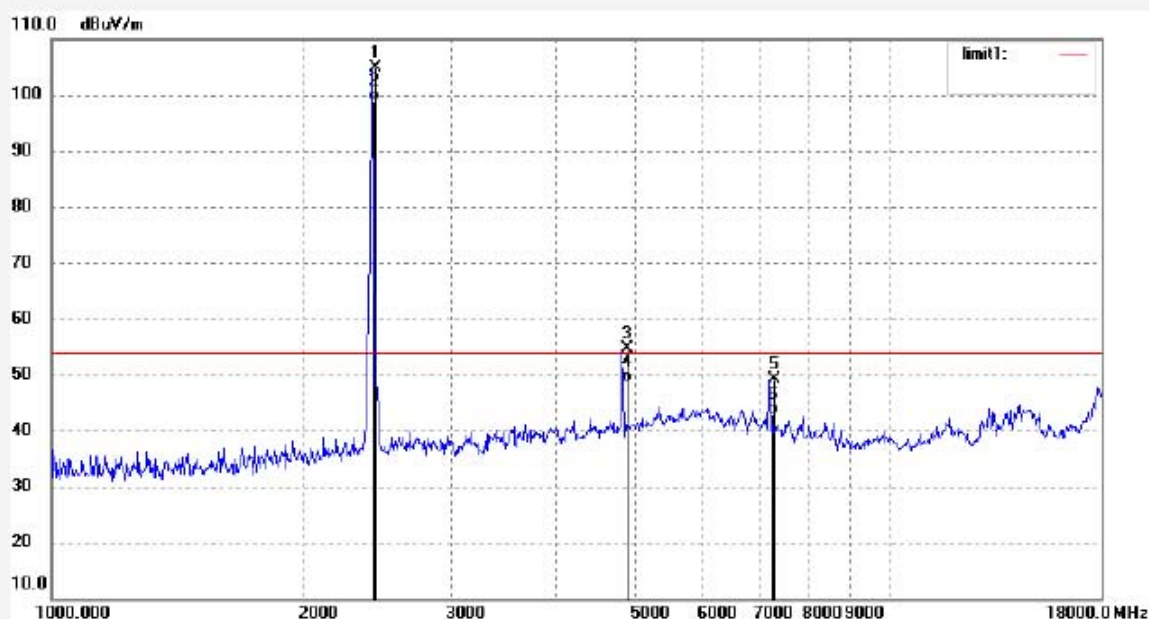

No.	Freq. (MHz)	Reading (dBuV/m)	Factor (dB)	Result (dBuV/m)	Limit (dBuV/m)	Margin (dB)	Detector	Height (cm)	Degree (deg.)	Remark
1	2437.015	112.33	-7.36	104.97	54.00	50.97	peak			
2	2437.015	106.21	-7.36	98.85	54.00	44.85	AVG			
3	4874.027	54.61	0.09	54.70	54.00	0.70	peak			
4	4874.027	48.49	0.09	48.58	54.00	-5.42	AVG			
5	7311.034	45.85	3.22	49.07	54.00	-4.93	peak			
6	7311.034	39.72	3.22	42.94	54.00	-11.06	AVG			



**ACCURATE TECHNOLOGY CO., LTD.**

F1,Bldg,A,Changyuan New Material Port Keyuan Rd,  
Science & Industry Park,Nanshan Shenzhen,P.R.China

Site: 966 chamber  
Tel:+86-0755-26503290  
Fax:+86-0755-26503396

Job No.: RTTE #4594	Polarization: Horizontal
Standard: FCC Class B 3M Radiated	Power Source: AC 120V/60Hz
Test item: Radiation Test	Date: 2010/04/17
Temp.( C)/Hum.(%) 25 C / 50 %	Time: 10:13:59
EUT: GuruPlug	Engineer Signature: Joe
Mode: TX Channal 6(802.11g)	Distance: 3m
Model: 003-GP11A101	
Manufacturer: Globalscale Technologies INC	

Note: Sample No.:100743 Report No.:ATE20100630

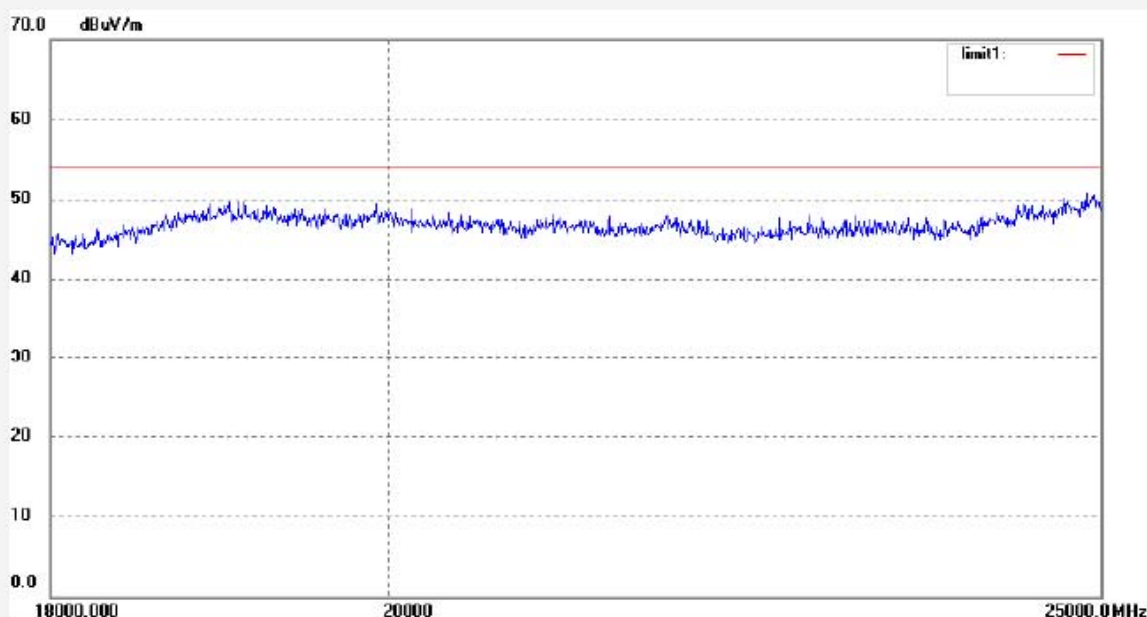

No.	Freq. (MHz)	Reading (dBuV/m)	Factor (dB)	Result (dBuV/m)	Limit (dBuV/m)	Margin (dB)	Detector	Height (cm)	Degree (deg.)	Remark
-----	-------------	------------------	-------------	-----------------	----------------	-------------	----------	-------------	---------------	--------



**ACCURATE TECHNOLOGY CO., LTD.**

F1,Bldg,A,Changyuan New Material Port Keyuan Rd,  
Science & Industry Park,Nanshan Shenzhen,P.R.China

Site: 966 chamber  
Tel:+86-0755-26503290  
Fax:+86-0755-26503396

Job No.: RTTE #4595	Polarization: Vertical
Standard: FCC Class B 3M Radiated	Power Source: AC 120V/60Hz
Test item: Radiation Test	Date: 2010/04/17
Temp.( C)/Hum.(%) 25 C / 50 %	Time: 10:17:51
EUT: GuruPlug	Engineer Signature: Joe
Mode: TX Channal 6(802.11g)	Distance: 3m
Model: 003-GP11A101	
Manufacturer: Globalscale Technologies INC	

Note: Sample No.:100743 Report No.:ATE20100630

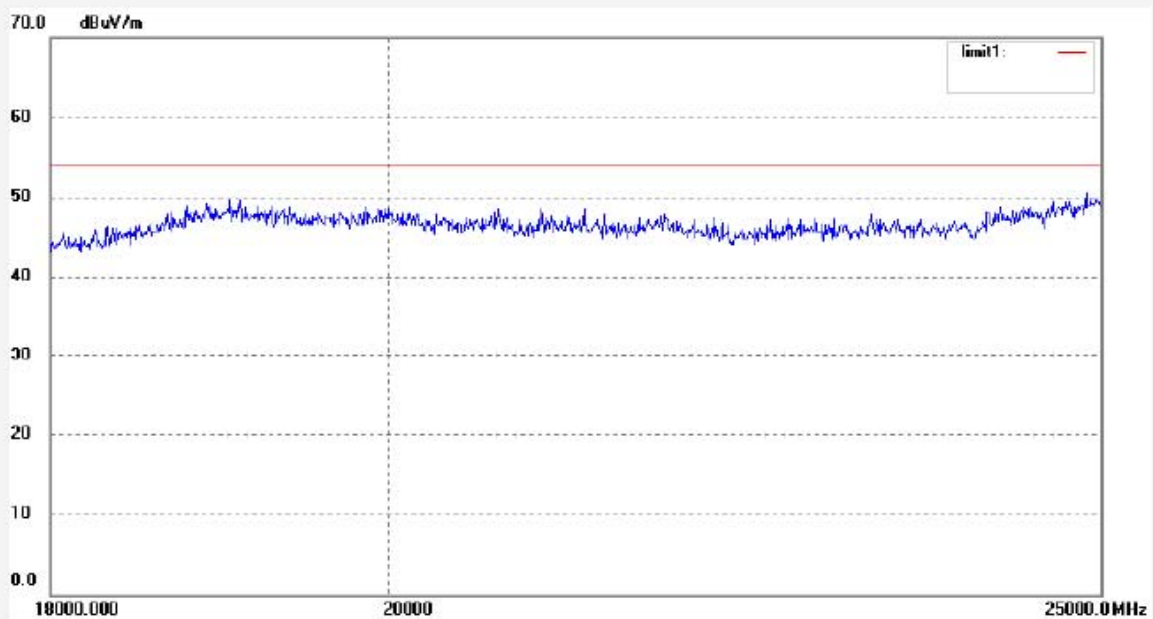

No.	Freq. (MHz)	Reading (dBuV/m)	Factor (dB)	Result (dBuV/m)	Limit (dBuV/m)	Margin (dB)	Detector	Height (cm)	Degree (deg.)	Remark
-----	-------------	------------------	-------------	-----------------	----------------	-------------	----------	-------------	---------------	--------



**ACCURATE TECHNOLOGY CO., LTD.**

F1,Bldg,A,Changyuan New Material Port Keyuan Rd,  
Science & Industry Park,Nanshan Shenzhen,P.R.China

Site: 966 chamber  
Tel:+86-0755-26503290  
Fax:+86-0755-26503396

Job No.: RTTE #4573	Polarization: Horizontal
Standard: FCC Class B 3M Radiated	Power Source: AC 120V/60Hz
Test item: Radiation Test	Date: 2010/04/16
Temp.( C)/Hum.(%) 25 C / 50 %	Time: 11:46:20
EUT: GuruPlug	Engineer Signature: Joe
Mode: TX Channal 11(802.11g)	Distance: 3m
Model: 003-GP11A101	
Manufacturer: Globalscale Technologies INC	

Note: Sample No.:100743 Report No.:ATE20100630

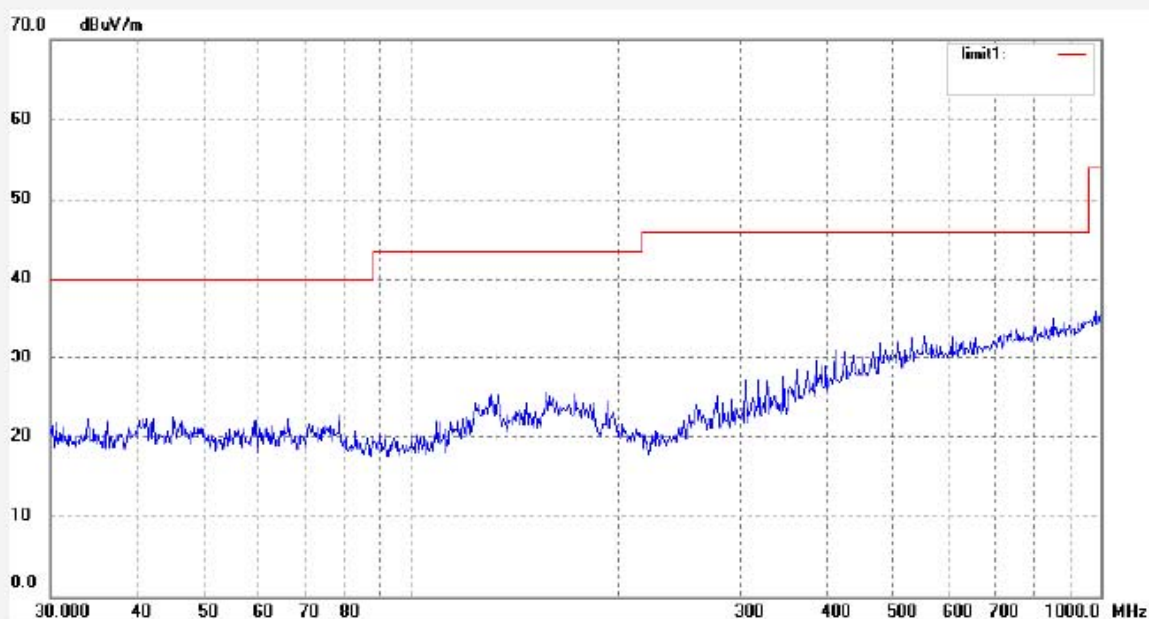

No.	Freq. (MHz)	Reading (dBuV/m)	Factor (dB)	Result (dBuV/m)	Limit (dBuV/m)	Margin (dB)	Detector	Height (cm)	Degree (deg.)	Remark
-----	-------------	------------------	-------------	-----------------	----------------	-------------	----------	-------------	---------------	--------





**ACCURATE TECHNOLOGY CO., LTD.**

F1,Bldg,A,Changyuan New Material Port Keyuan Rd,  
Science & Industry Park,Nanshan Shenzhen,P.R.China

Site: 966 chamber  
Tel:+86-0755-26503290  
Fax:+86-0755-26503396

Job No.: RTTE #4572	Polarization: Vertical
Standard: FCC Class B 3M Radiated	Power Source: AC 120V/60Hz
Test item: Radiation Test	Date: 2010/04/16
Temp.( C)/Hum.(%) 25 C / 50 %	Time: 11:42:36
EUT: GuruPlug	Engineer Signature: Joe
Mode: TX Channal 11(802.11g)	Distance: 3m
Model: 003-GP11A101	
Manufacturer: Globalscale Technologies INC	

Note: Sample No.:100743 Report No.:ATE20100630

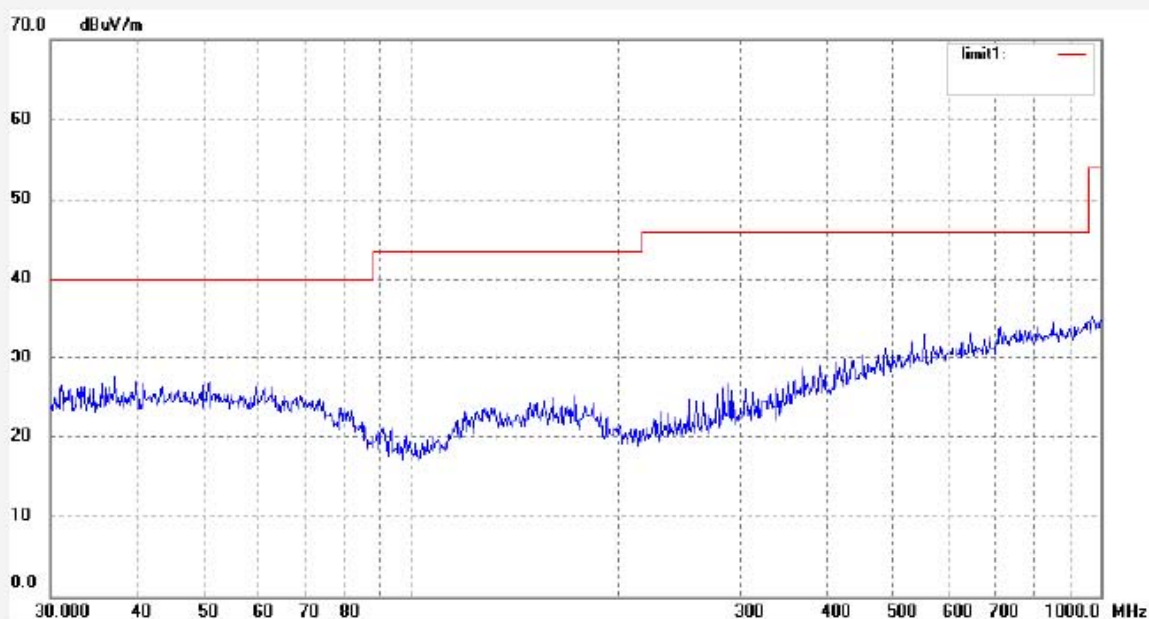

No.	Freq. (MHz)	Reading (dBuV/m)	Factor (dB)	Result (dBuV/m)	Limit (dBuV/m)	Margin (dB)	Detector	Height (cm)	Degree (deg.)	Remark
-----	-------------	------------------	-------------	-----------------	----------------	-------------	----------	-------------	---------------	--------



**ACCURATE TECHNOLOGY CO., LTD.**

F1,Bldg,A,Changyuan New Material Port Keyuan Rd,  
Science & Industry Park,Nanshan Shenzhen,P.R.China

Site: 966 chamber  
Tel:+86-0755-26503290  
Fax:+86-0755-26503396

Job No.: RTTE #4585	Polarization: Horizontal
Standard: FCC Class B 3M Radiated	Power Source: AC 120V/60Hz
Test item: Radiation Test	Date: 2010/04/17
Temp.( C)/Hum.(%) 25 C / 50 %	Time: 9:30:57
EUT: GuruPlug	Engineer Signature: Joe
Mode: TX Channal 11(802.11g)	Distance: 3m
Model: 003-GP11A101	
Manufacturer: Globalscale Technologies INC	

Note: Sample No.:100743 Report No.:ATE20100630

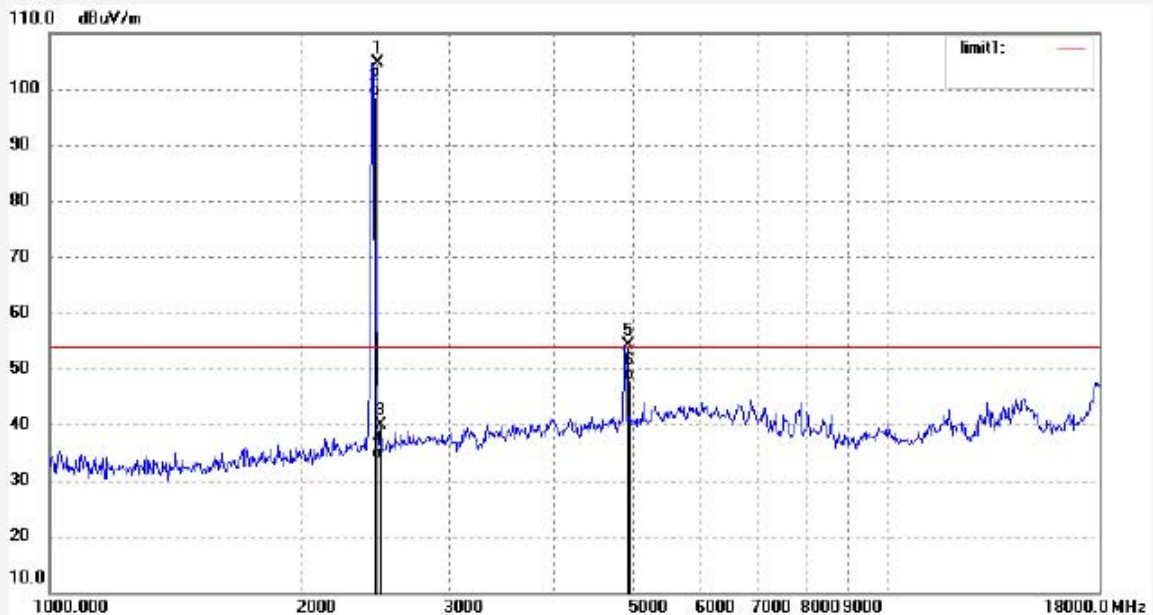

No.	Freq. (MHz)	Reading (dBuV/m)	Factor (dB)	Result (dBuV/m)	Limit (dBuV/m)	Margin (dB)	Detector	Height (cm)	Degree (deg.)	Remark
1	2462.016	112.08	-7.35	104.73	54.00	50.73	peak			
2	2462.016	106.00	-7.35	98.65	54.00	44.65	AVG			
3	2483.500	47.25	-7.37	39.88	54.00	-14.12	peak			
4	2483.500	41.17	-7.37	33.80	54.00	-20.20	AVG			
5	4924.026	53.78	0.34	54.12	54.00	0.12	peak			
6	4924.026	47.65	0.34	47.99	54.00	-6.01	AVG			



**ACCURATE TECHNOLOGY CO., LTD.**

F1,Bldg,A,Changyuan New Material Port Keyuan Rd,  
Science & Industry Park,Nanshan Shenzhen,P.R.China

Site: 966 chamber  
Tel:+86-0755-26503290  
Fax:+86-0755-26503396

Job No.: RTTE #4584	Polarization: Vertical
Standard: FCC Class B 3M Radiated	Power Source: AC 120V/60Hz
Test item: Radiation Test	Date: 2010/04/17
Temp.( C)/Hum.(%) 25 C / 50 %	Time: 9:26:48
EUT: GuruPlug	Engineer Signature: Joe
Mode: TX Channal 11(802.11g)	Distance: 3m
Model: 003-GP11A101	
Manufacturer: Globalscale Technologies INC	

Note: Sample No.:100743 Report No.:ATE20100630

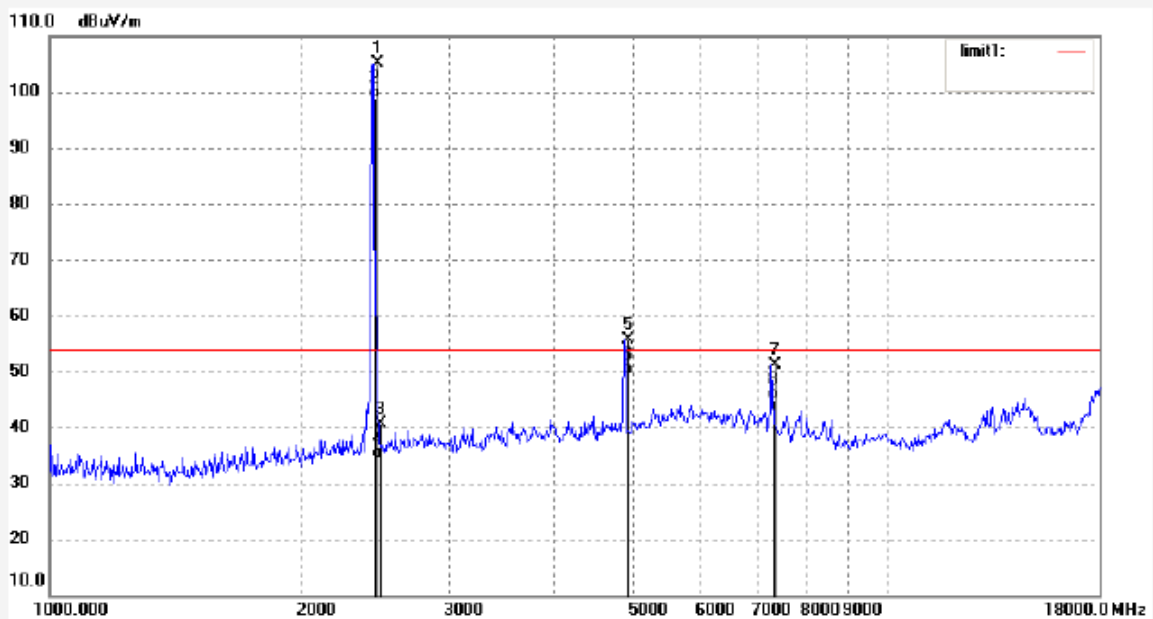

No.	Freq. (MHz)	Reading (dBuV/m)	Factor (dB)	Result (dBuV/m)	Limit (dBuV/m)	Margin (dB)	Detector	Height (cm)	Degree (deg.)	Remark
1	2462.016	112.46	-7.35	105.11	54.00	51.11	peak			
2	2462.016	106.34	-7.35	98.99	54.00	44.99	AVG			
3	2483.500	47.92	-7.37	40.55	54.00	-13.45	peak			
4	2483.500	41.77	-7.37	34.40	54.00	-19.60	AVG			
5	4924.026	55.18	0.34	55.52	54.00	1.52	peak			
6	4924.026	49.08	0.34	49.42	54.00	-4.58	AVG			
7	7386.035	47.64	3.39	51.03	54.00	-2.97	peak			
8	7386.035	41.54	3.39	44.93	54.00	-9.07	AVG			



**ACCURATE TECHNOLOGY CO., LTD.**

F1,Bldg,A,Changyuan New Material Port Keyuan Rd,  
Science & Industry Park,Nanshan Shenzhen,P.R.China

Site: 966 chamber  
Tel:+86-0755-26503290  
Fax:+86-0755-26503396

Job No.: RTTE #4597	Polarization: Horizontal
Standard: FCC Class B 3M Radiated	Power Source: AC 120V/60Hz
Test item: Radiation Test	Date: 2010/04/17
Temp.( C)/Hum.(%) 25 C / 50 %	Time: 10:26:12
EUT: GuruPlug	Engineer Signature: Joe
Mode: TX Channal 11(802.11g)	Distance: 3m
Model: 003-GP11A101	
Manufacturer: Globalscale Technologies INC	

Note: Sample No.:100743 Report No.:ATE20100630

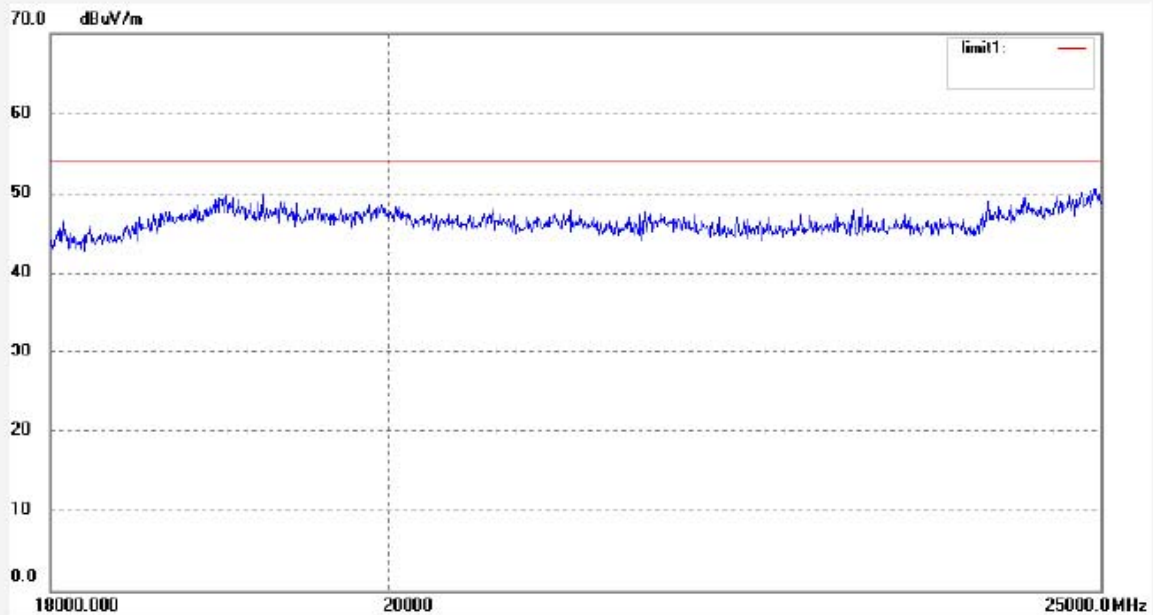

No.	Freq. (MHz)	Reading (dBuV/m)	Factor (dB)	Result (dBuV/m)	Limit (dBuV/m)	Margin (dB)	Detector	Height (cm)	Degree (deg.)	Remark
-----	-------------	------------------	-------------	-----------------	----------------	-------------	----------	-------------	---------------	--------



**ACCURATE TECHNOLOGY CO., LTD.**

F1,Bldg,A,Changyuan New Material Port Keyuan Rd,  
Science & Industry Park,Nanshan Shenzhen,P.R.China

Site: 966 chamber  
Tel:+86-0755-26503290  
Fax:+86-0755-26503396

Job No.: RTTE #4596	Polarization: Vertical
Standard: FCC Class B 3M Radiated	Power Source: AC 120V/60Hz
Test item: Radiation Test	Date: 2010/04/17
Temp.( C)/Hum.(%) 25 C / 50 %	Time: 10:22:20
EUT: GuruPlug	Engineer Signature: Joe
Mode: TX Channal 11(802.11g)	Distance: 3m
Model: 003-GP11A101	
Manufacturer: Globalscale Technologies INC	

Note: Sample No.:100743 Report No.:ATE20100630

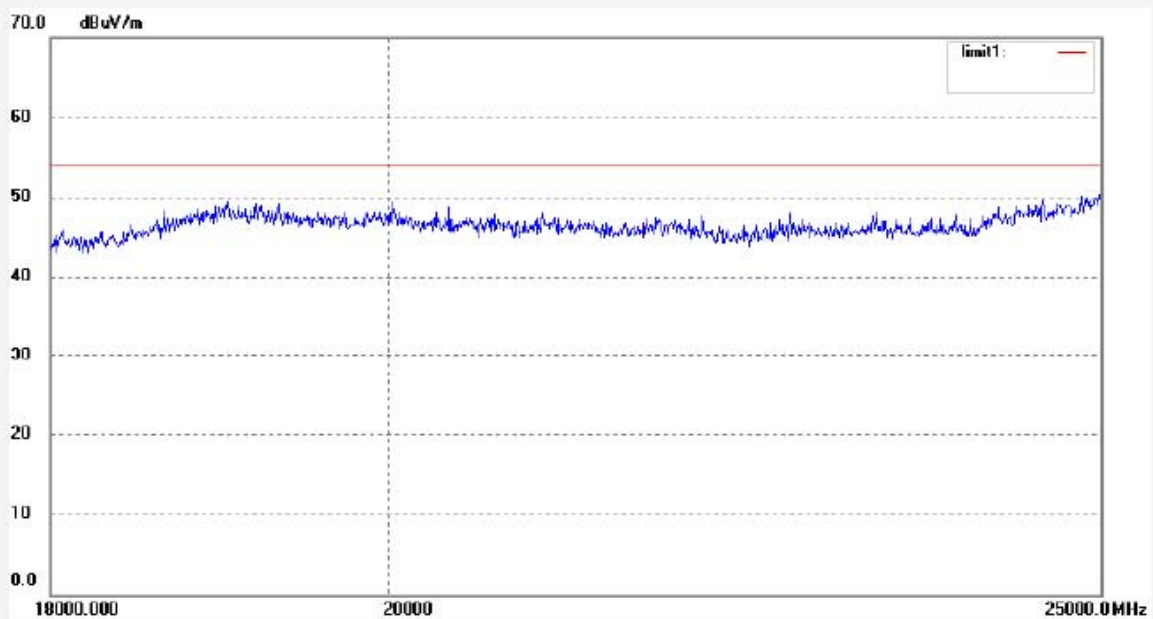

No.	Freq. (MHz)	Reading (dBuV/m)	Factor (dB)	Result (dBuV/m)	Limit (dBuV/m)	Margin (dB)	Detector	Height (cm)	Degree (deg.)	Remark
-----	-------------	------------------	-------------	-----------------	----------------	-------------	----------	-------------	---------------	--------

## 10. CONDUCTED SPURIOUS EMISSION COMPLIANCE TEST

### 10.1. Block Diagram of Test Setup

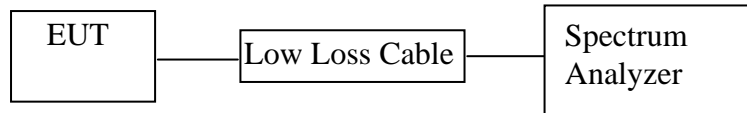

(EUT: GuruPlug)

### 10.2. The Requirement For Section 15.247(d)

Section 15.247(d): In any 100 kHz bandwidth outside the frequency band in which the spread spectrum or digitally modulated intentional radiator is operating, the radio frequency power that is produced by the intentional radiator shall be at least 20 dB below that in the 100 kHz bandwidth within the band that contains the highest level of the desired power, based on either an RF conducted or a radiated measurement, provided the transmitter demonstrates compliance with the peak conducted power limits. If the transmitter complies with the conducted power limits based on the use of RMS averaging over a time interval, as permitted under paragraph (b)(3) of this section, the attenuation required under this paragraph shall be 30 dB instead of 20 dB. Attenuation below the general limits specified in Section 15.209(a) is not required. In addition, radiated emissions which fall in the restricted bands, as defined in Section 15.205(a), must also comply with the radiated emission limits specified in Section 15.209(a).

### 10.3. EUT Configuration on Measurement

The following equipment are installed on the emission measurement to meet the commission requirements and operating regulations in a manner which tends to maximize its emission characteristics in normal application.

#### 10.3.1. GuruPlug (EUT)

Model Number	:	003-GP11A101
Serial Number	:	N/A
Manufacturer	:	Globalscale Technologies INC

## 10.4. Operating Condition of EUT

10.4.1. Setup the EUT and simulator as shown as Section 10.1.

10.4.2. Turn on the power of all equipment.

10.4.3. Let the EUT work in TX modes measure it. The transmit frequency are 2412-2462MHz. We select 2412MHz, 2437MHz, 2462MHz TX frequency to transmit.

## 10.5. Test Procedure

10.5.1. The transmitter output was connected to the spectrum analyzer via a low loss cable.

10.5.2. Set RBW of spectrum analyzer to 100kHz and VBW to 300kHz.

10.5.3. The Conducted Spurious Emission was measured and recorded.

## 10.6. Test Result

**Pass.**

The spectrum analyzer plots are attached as below.

**TX 802.11b Channel Low 2412MHz (30MHz-1GHz)**

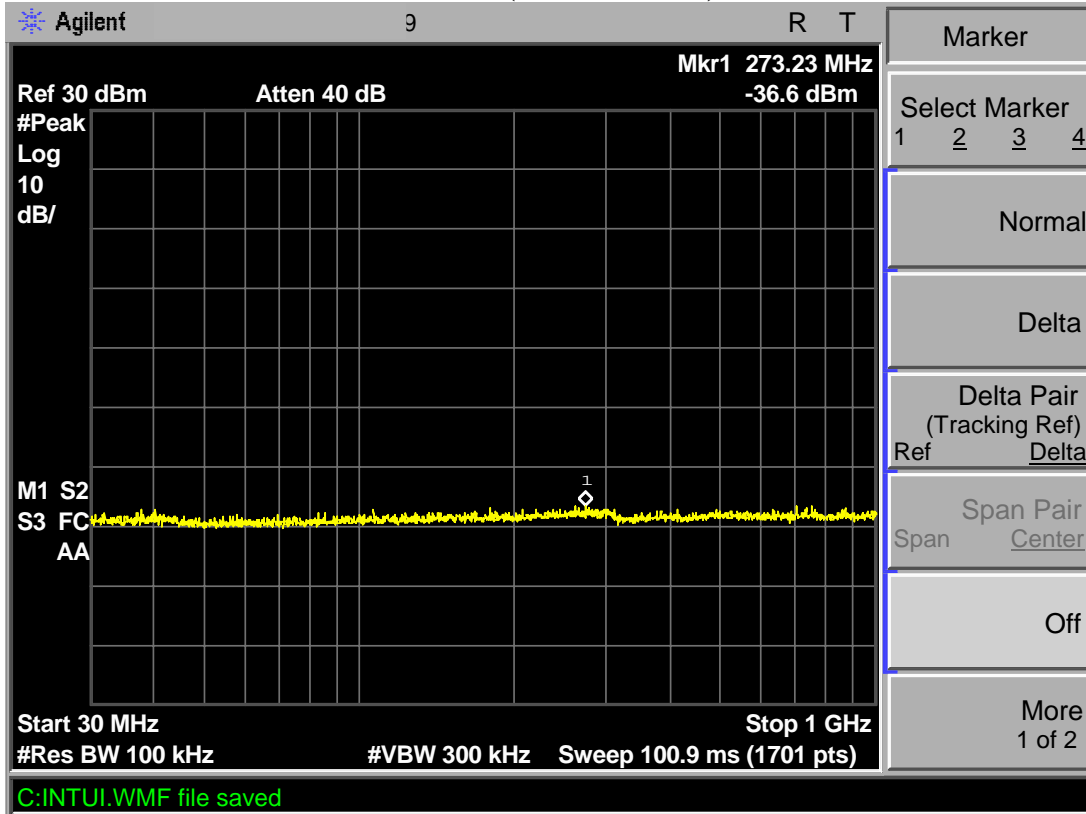

**TX 802.11b Channel Low 2412MHz (1GHz-5GHz)**

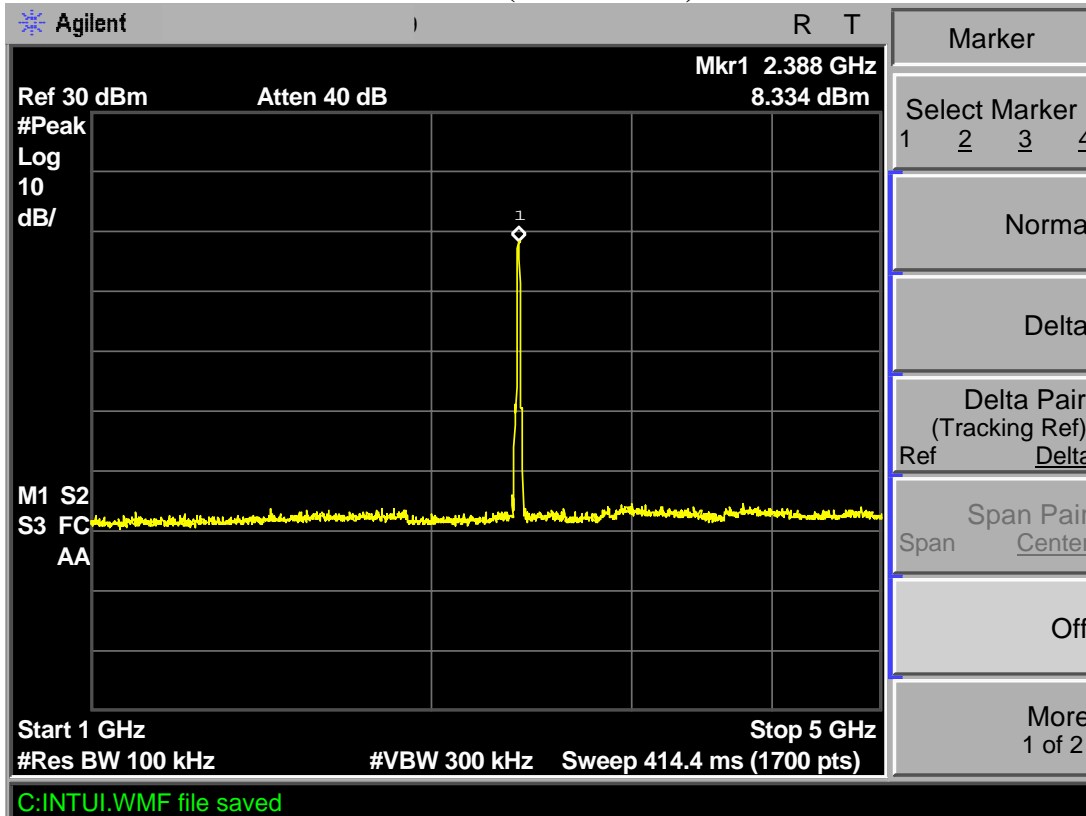



**TX 802.11b Channel Low 2412MHz (5GHz-10GHz)**

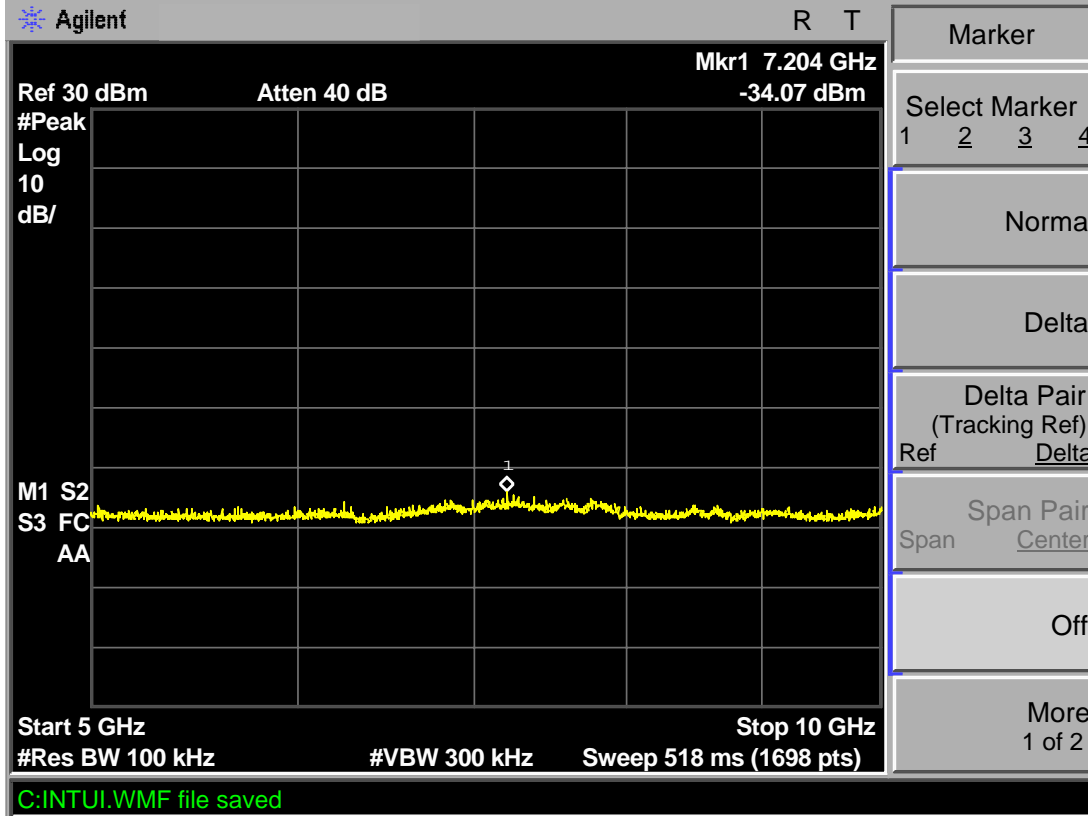

**TX 802.11b Channel Low 2412MHz (10GHz-15GHz)**

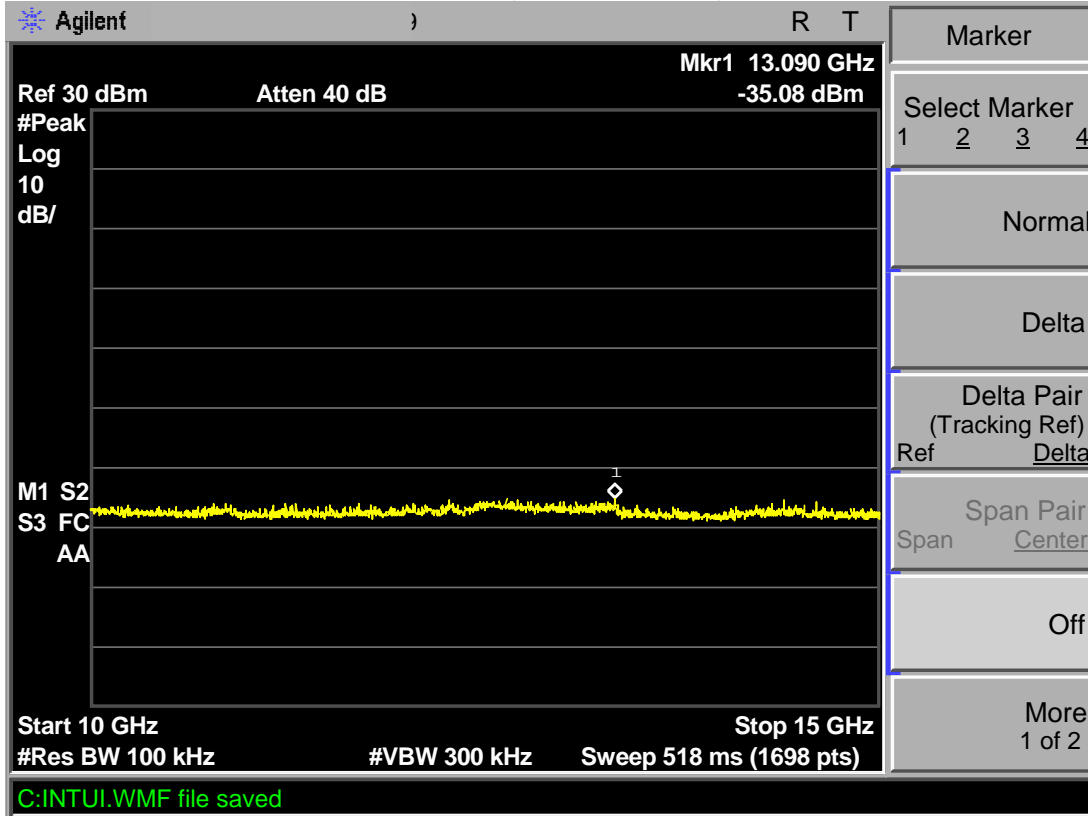

### TX 802.11b Channel Low 2412MHz (15GHz-20GHz)

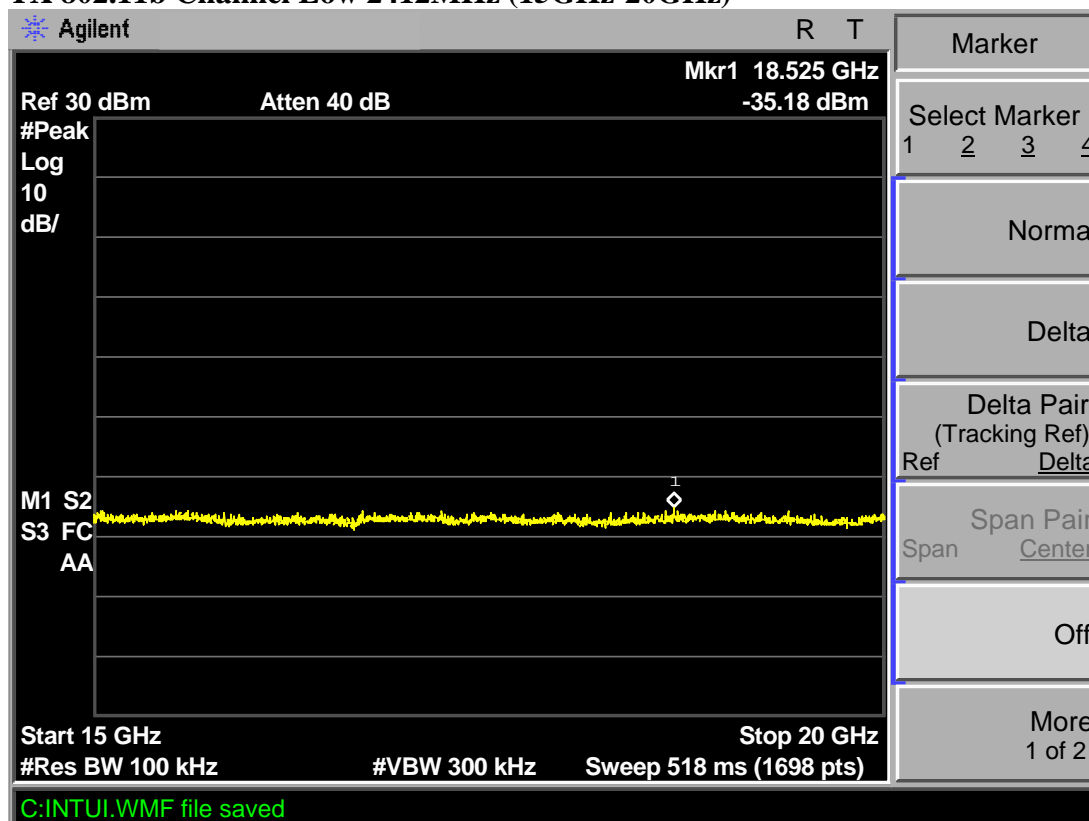

### TX 802.11b Channel Low 2412MHz (20GHz-25GHz)

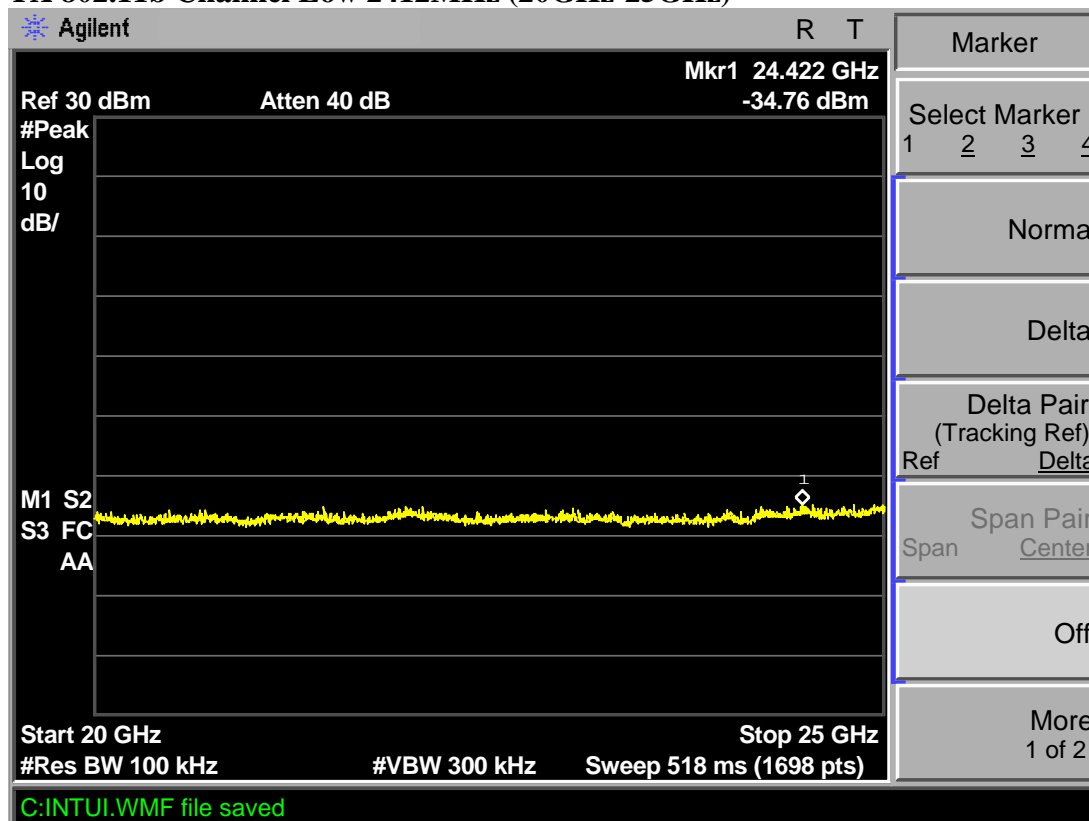

**TX 802.11b Channel Middle 2437MHz (30MHz-1GHz)**

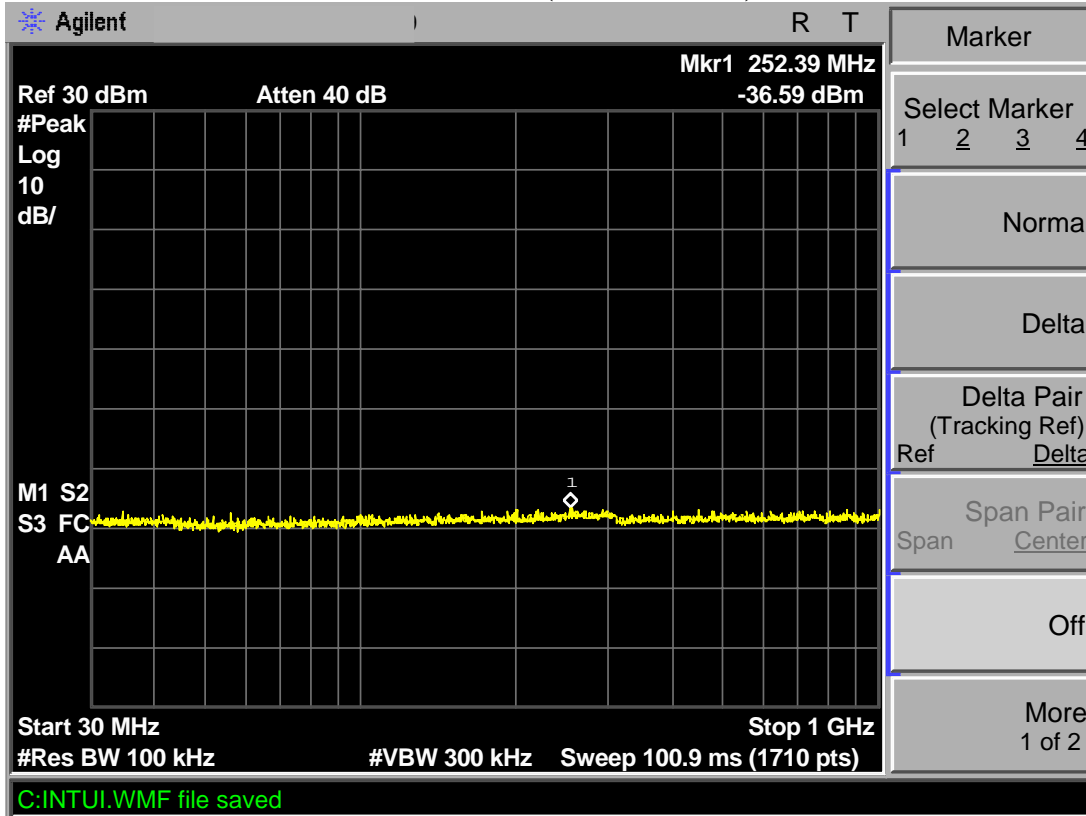

**TX 802.11b Channel Middle 2437MHz (1GHz-5GHz)**

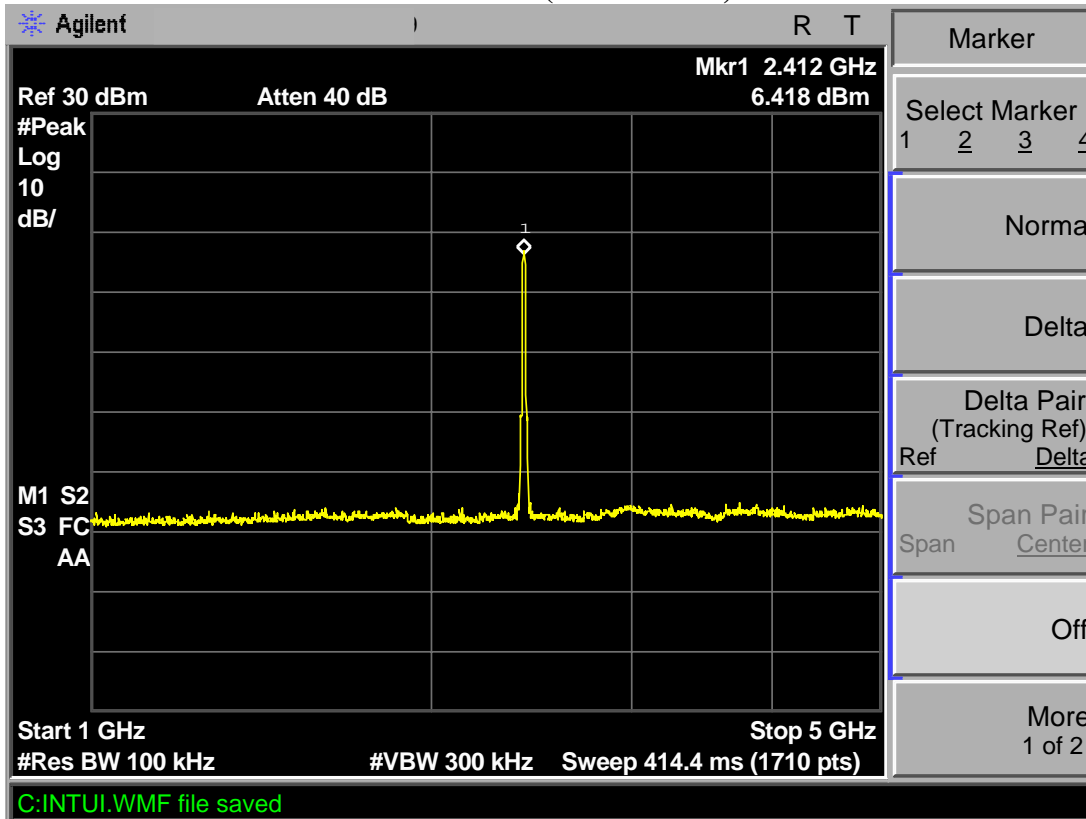

### TX 802.11b Channel Middle 2437MHz (5GHz-10GHz)

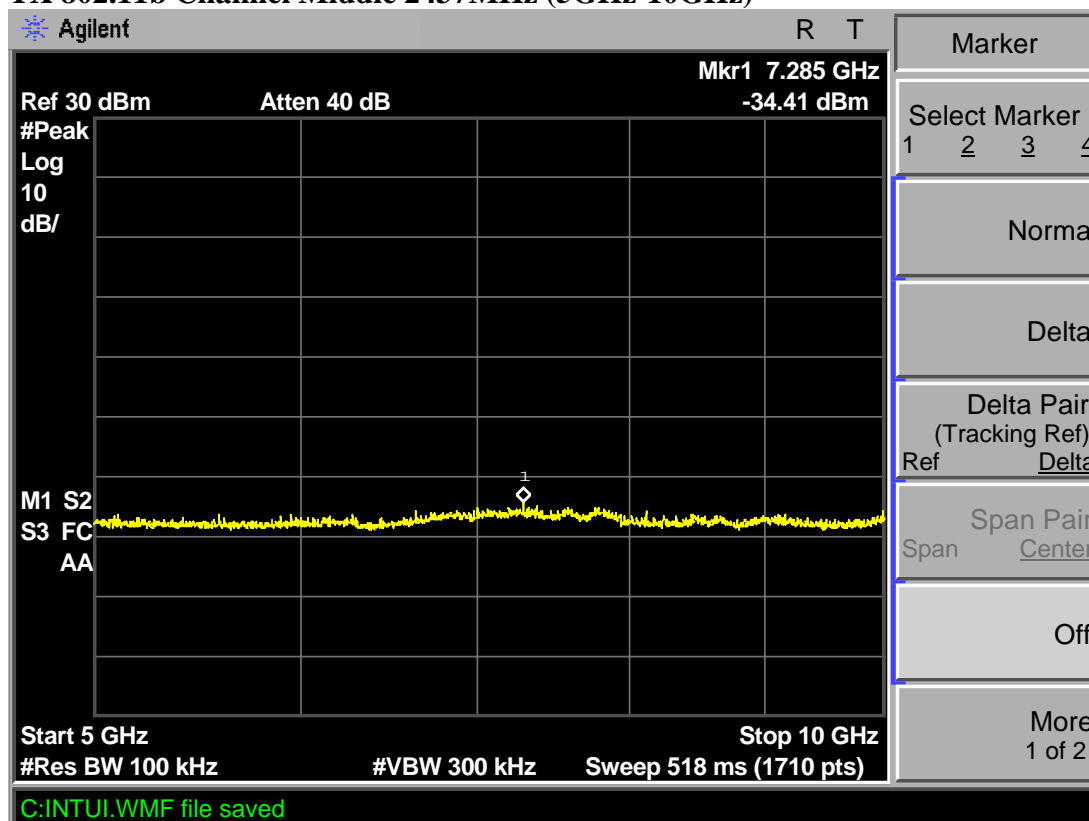

### TX 802.11b Channel Middle 2437MHz (10GHz-15GHz)

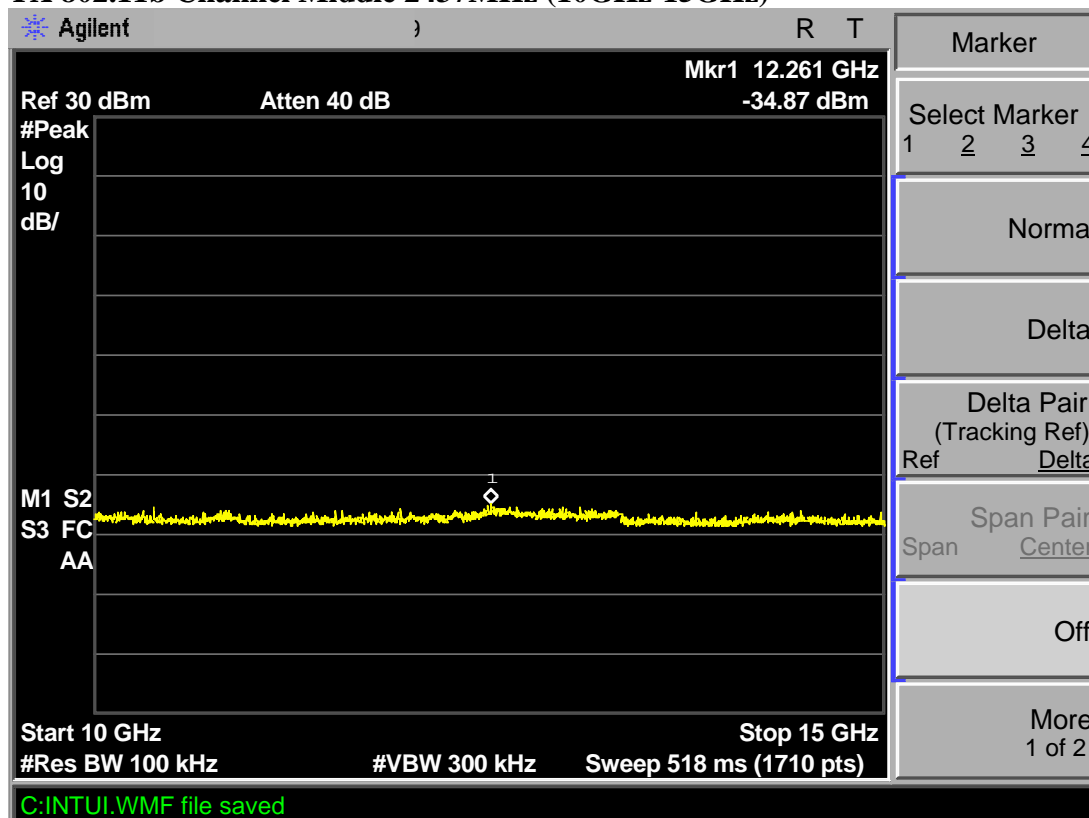

**TX 802.11b Channel Middle 2437MHz (15GHz-20GHz)**

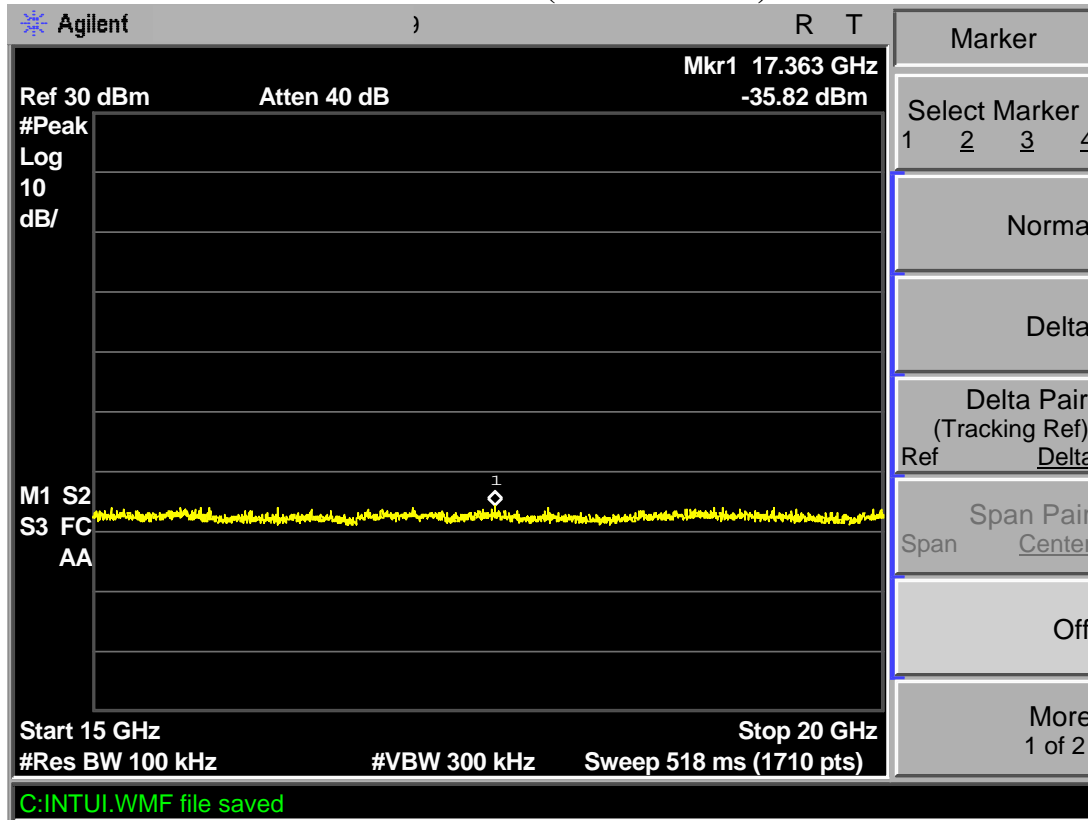

**TX 802.11b Channel Middle 2437MHz (20GHz-25GHz)**

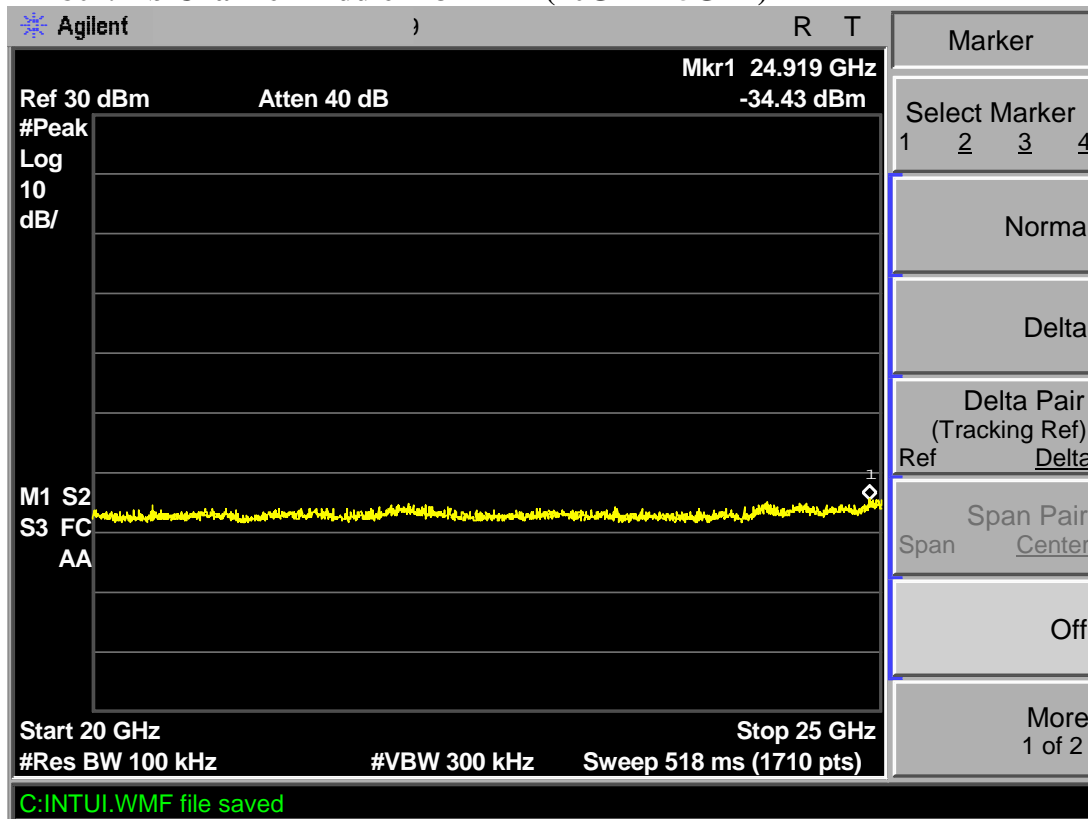

**TX 802.11b Channel High 2462MHz (30MHz-1GHz)**

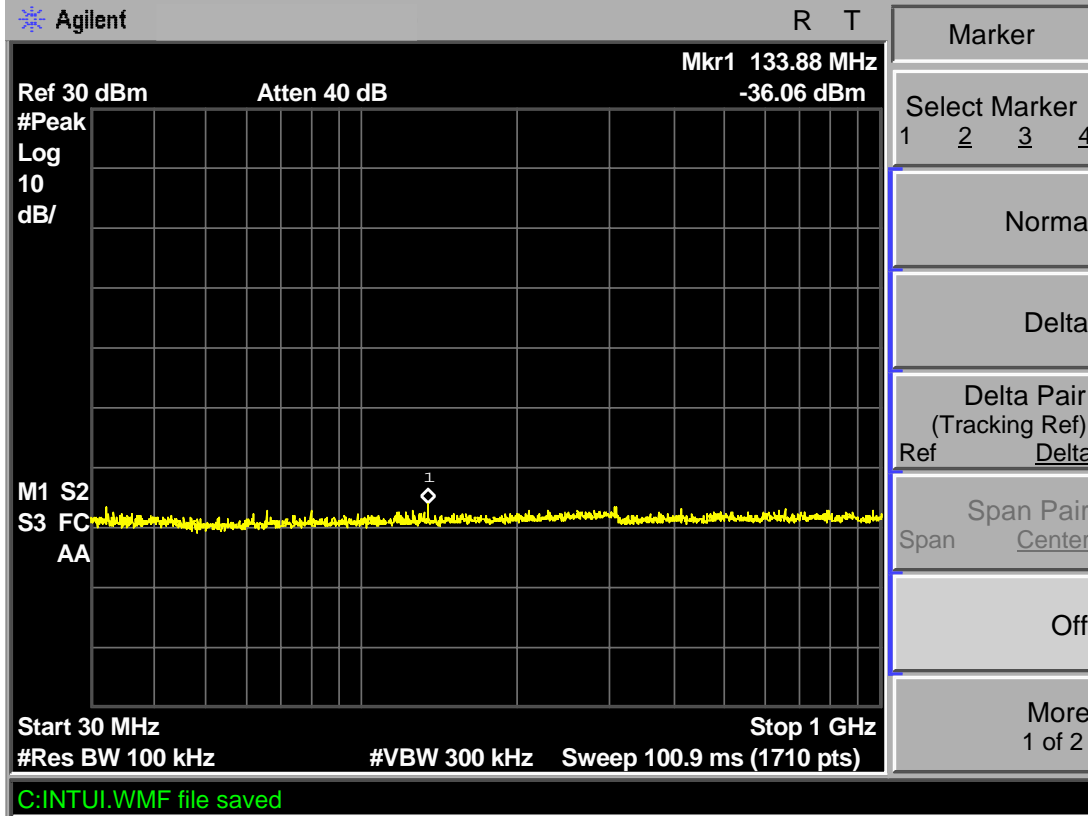

**TX 802.11b Channel High 2462MHz (1GHz-5GHz)**

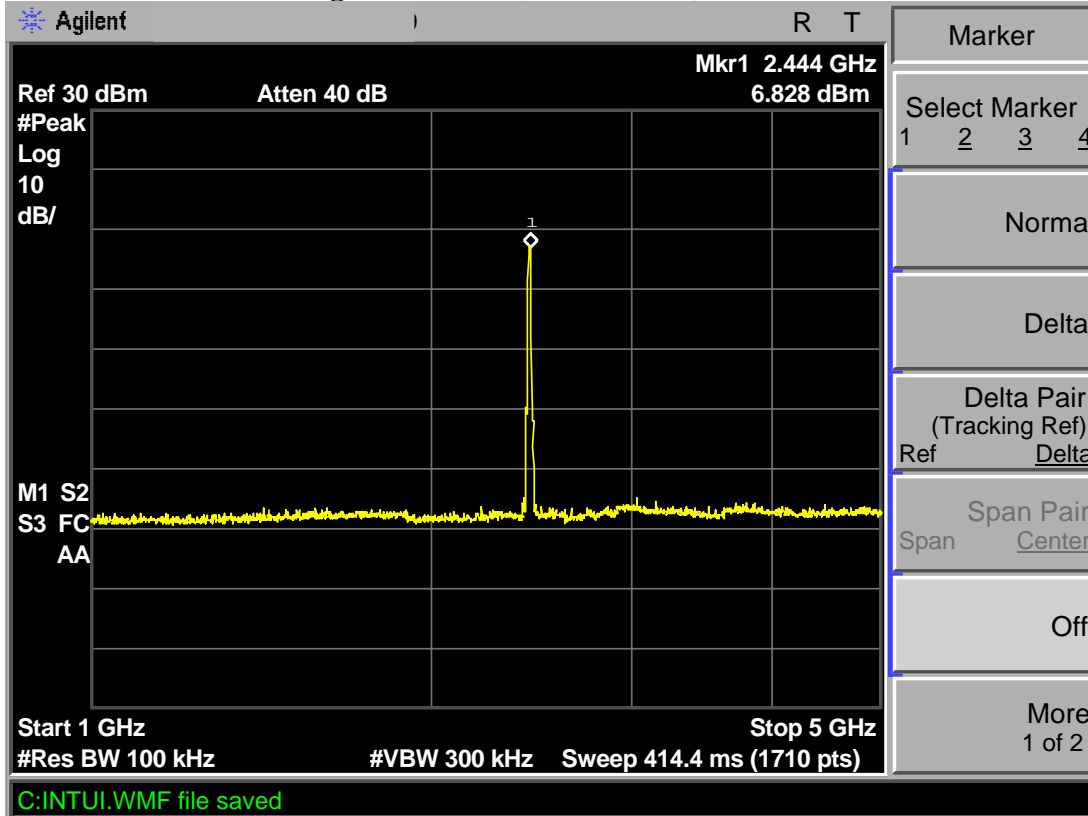

**TX 802.11b Channel High 2462MHz (5GHz-10GHz)**

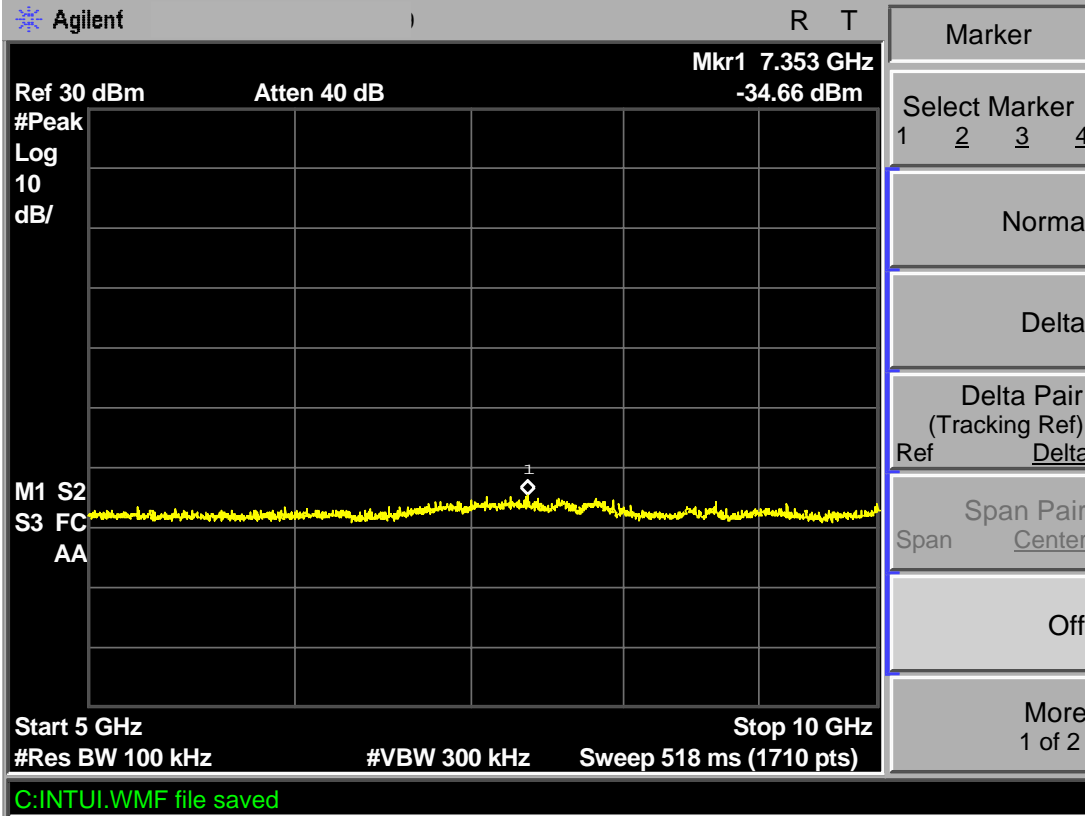

**TX 802.11b Channel High 2462MHz (10GHz-15GHz)**

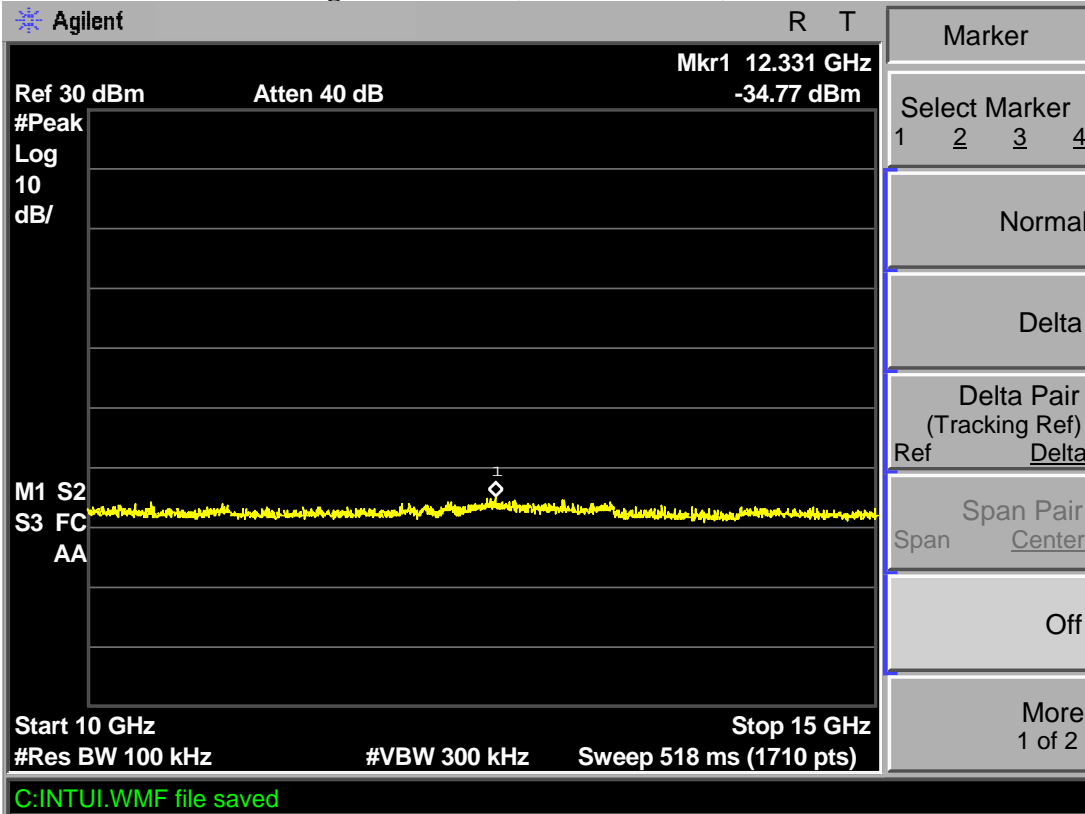

**TX 802.11b Channel High 2462MHz (15GHz-20GHz)**

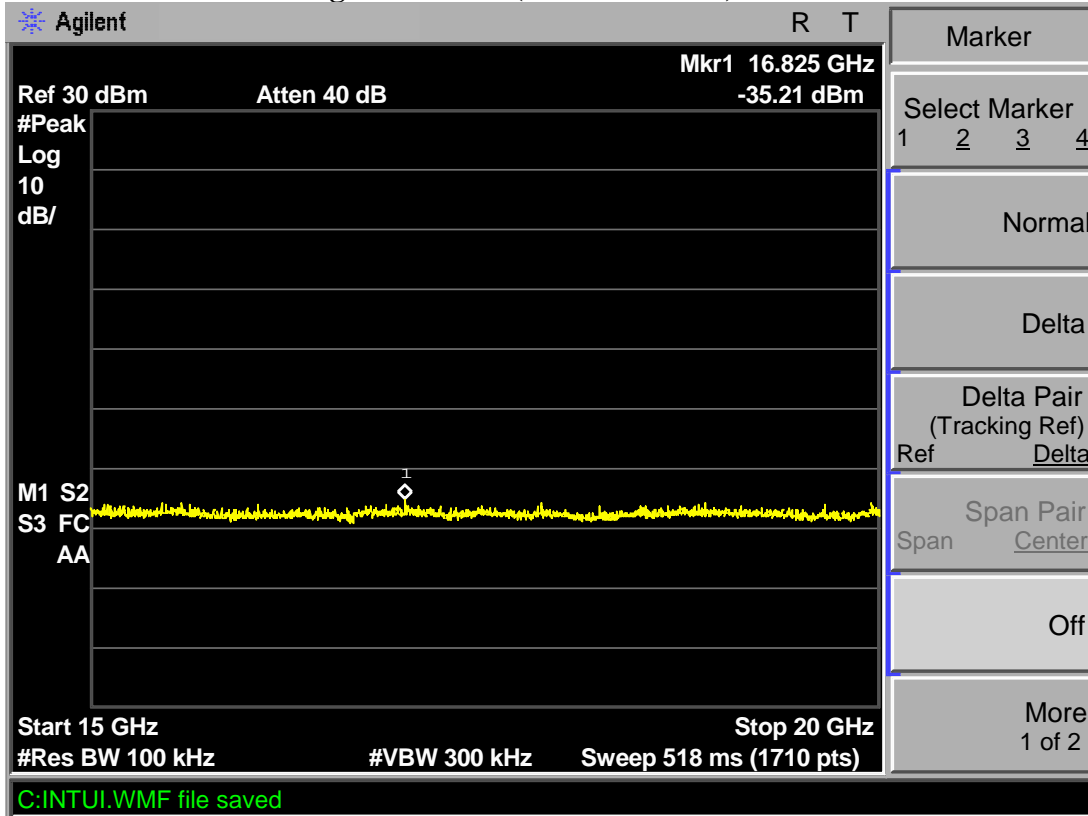

**TX 802.11b Channel High 2462MHz (20GHz-25GHz)**

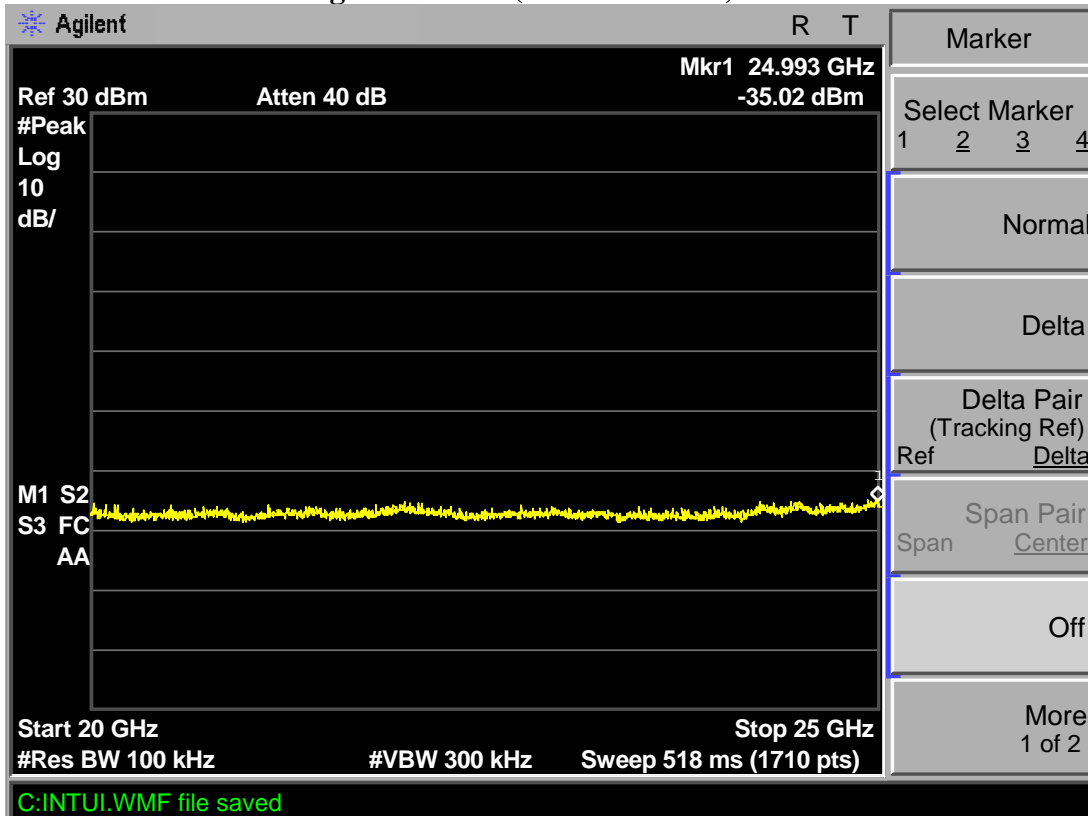



**TX 802.11g Channel Low 2412MHz (30MHz-1GHz)**

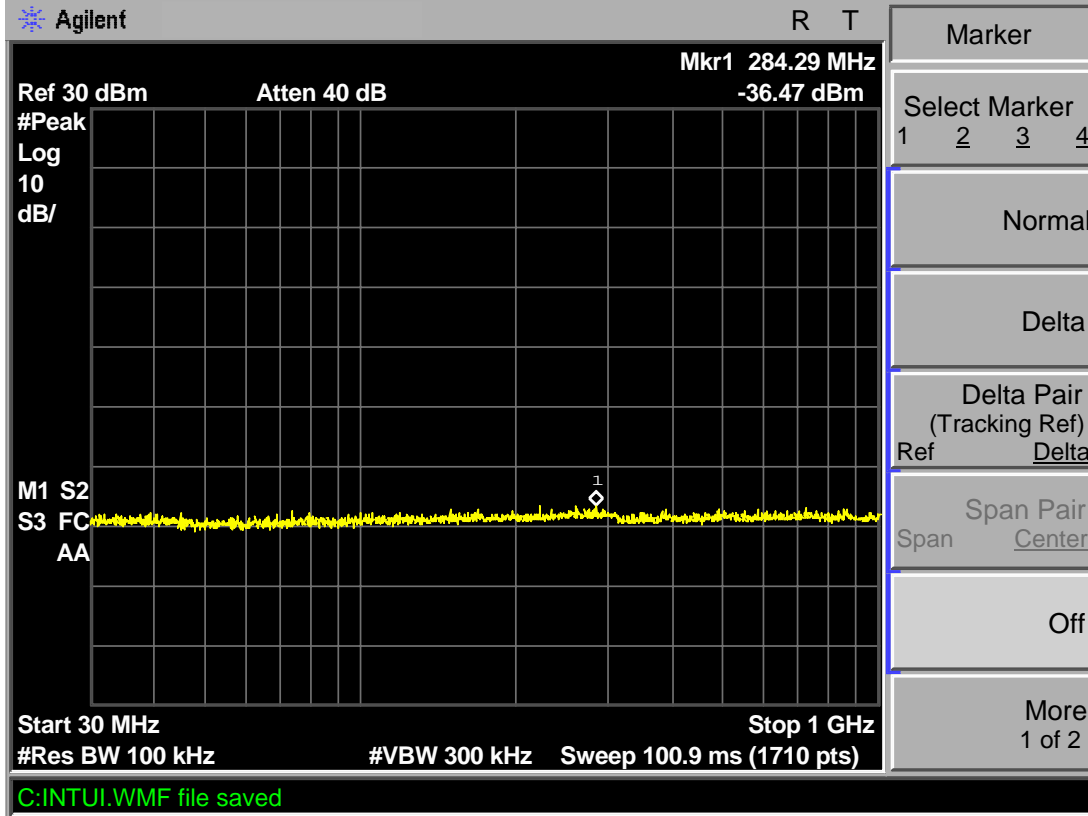

**TX 802.11g Channel Low 2412MHz (1GHz-5GHz)**

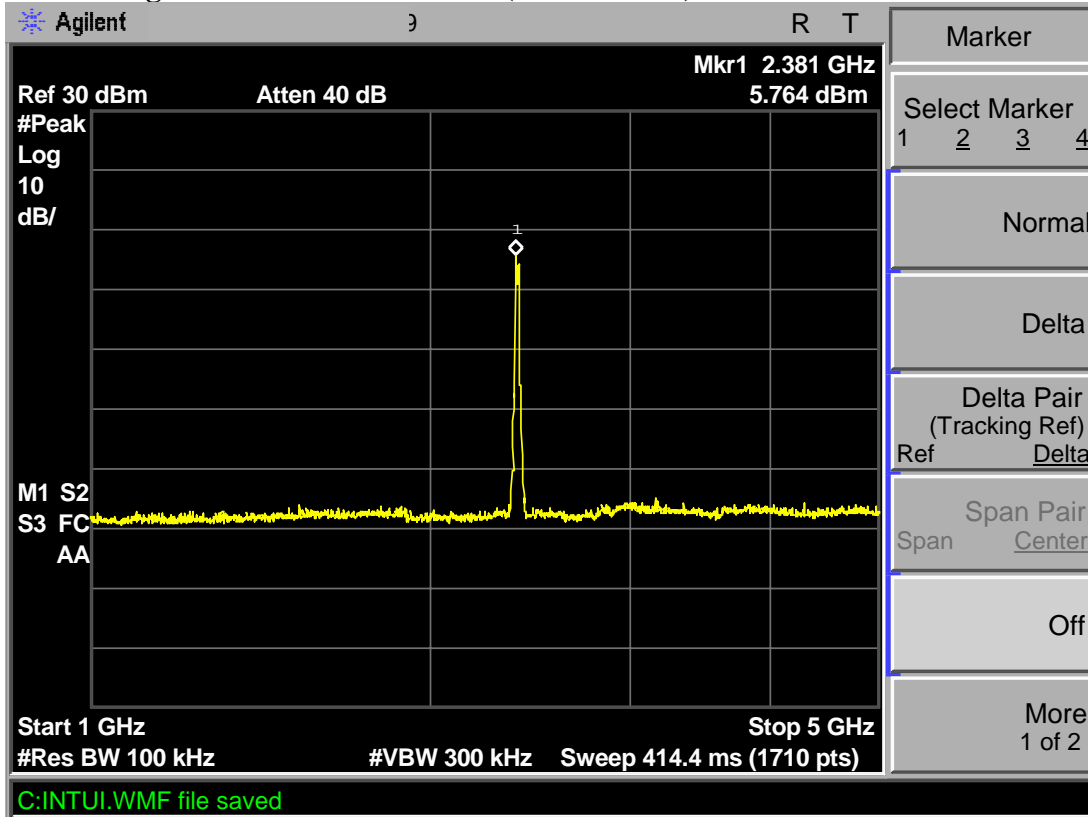

### TX 802.11g Channel Low 2412MHz (5GHz-10GHz)

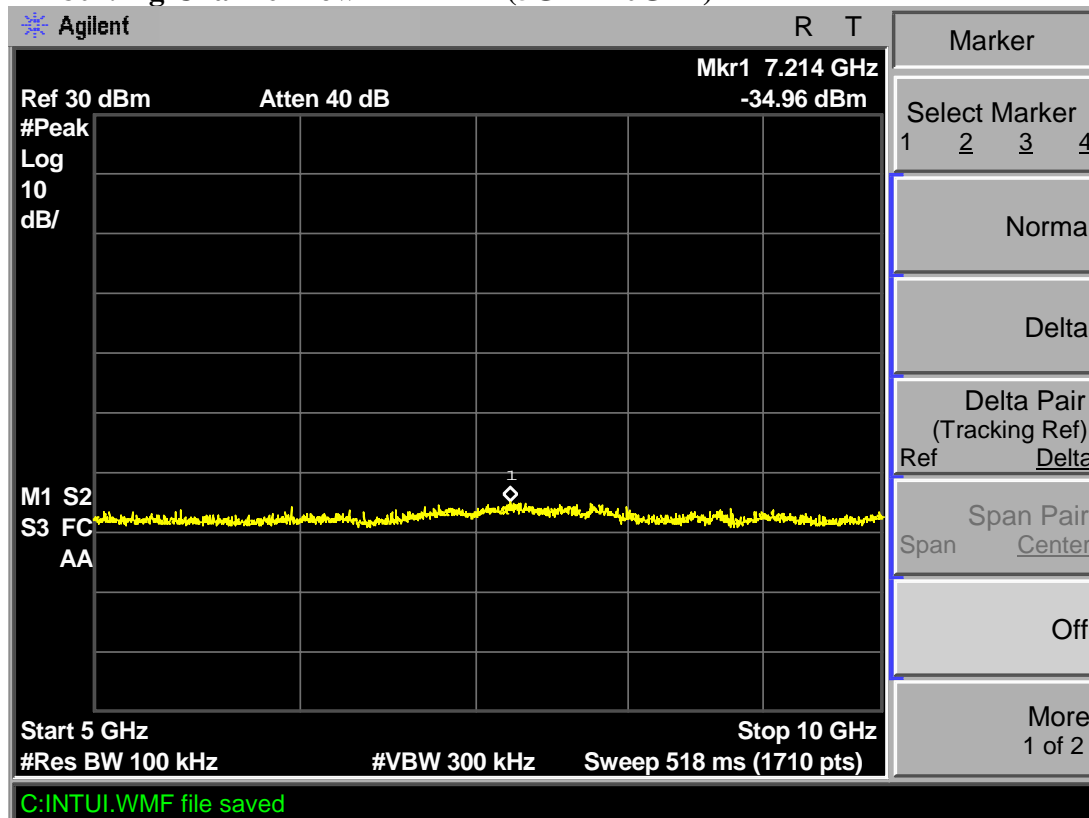

### TX 802.11g Channel Low 2412MHz (10GHz-15GHz)

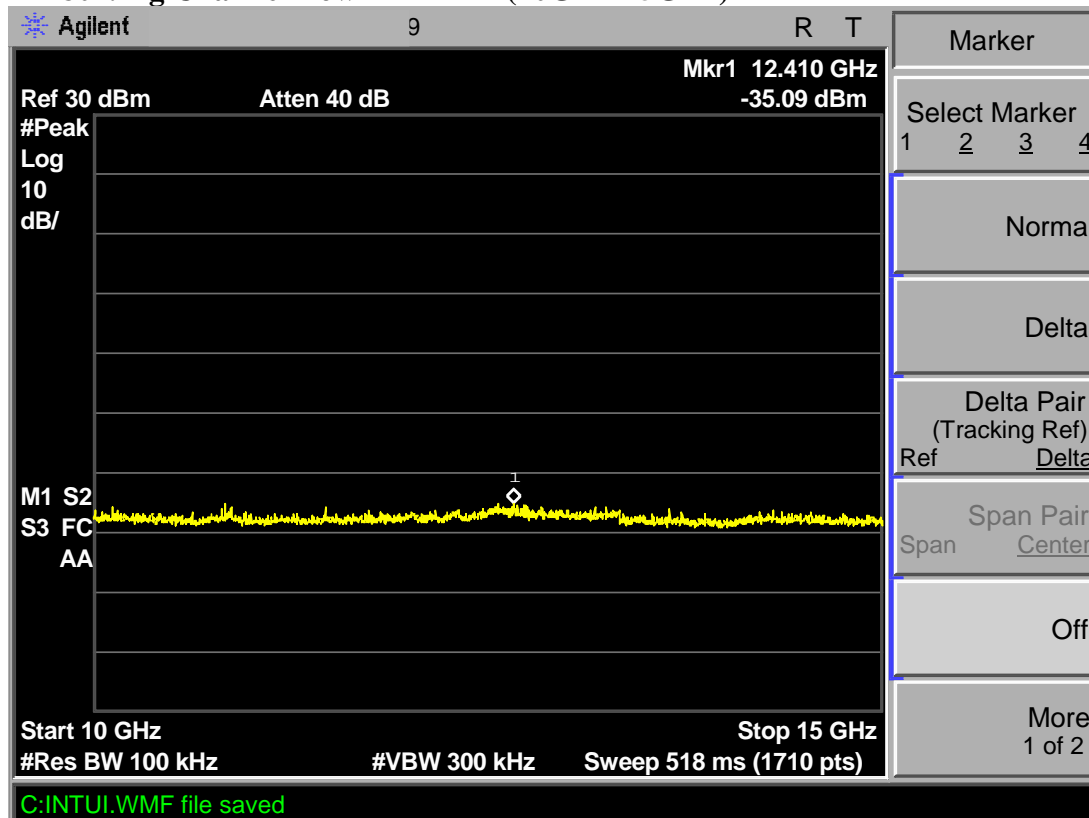

**TX 802.11g Channel Low 2412MHz (15GHz-20GHz)**

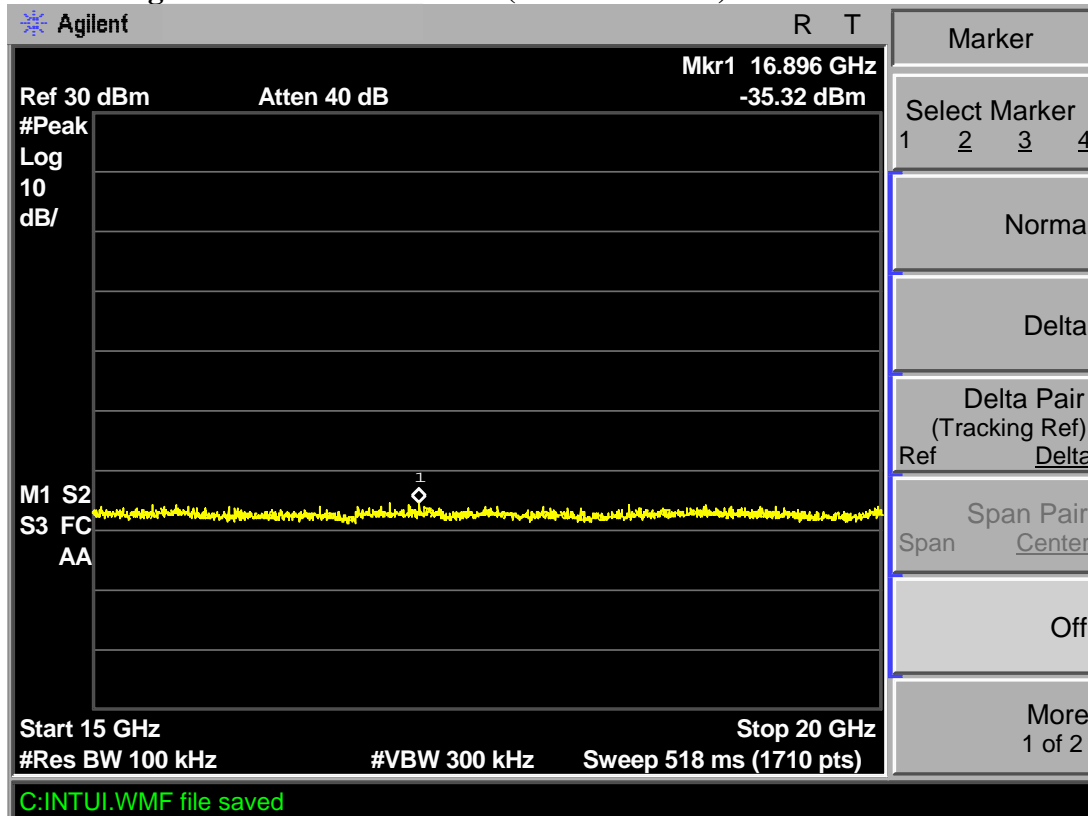

**TX 802.11g Channel Low 2412MHz (20GHz-25GHz)**

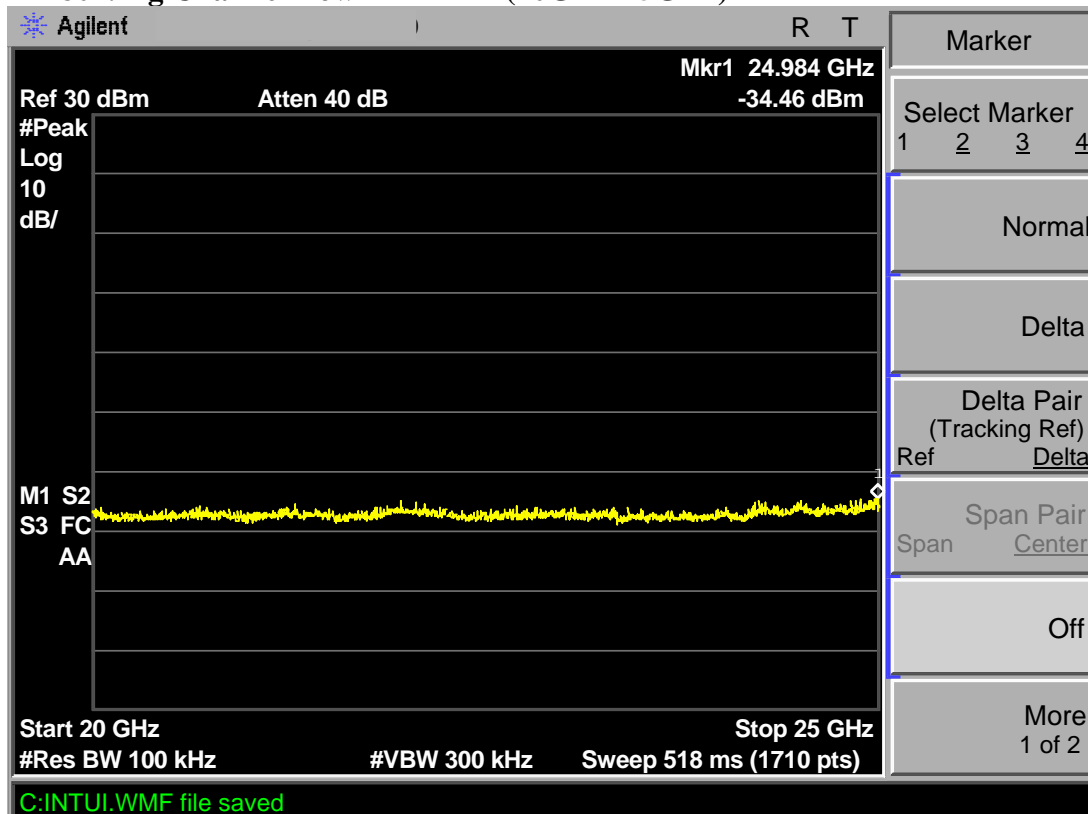

**TX 802.11g Channel Middle 2437MHz (30MHz-1GHz)**

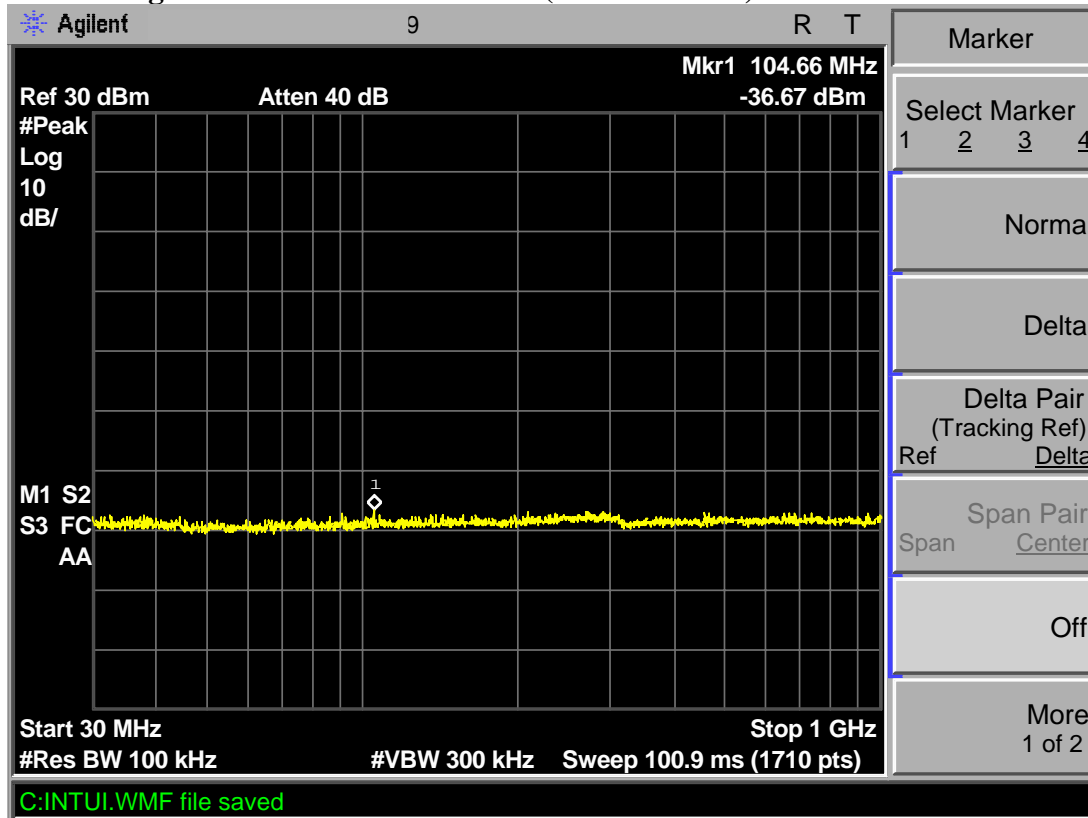

**TX 802.11g Channel Middle 2437MHz (1GHz-5GHz)**

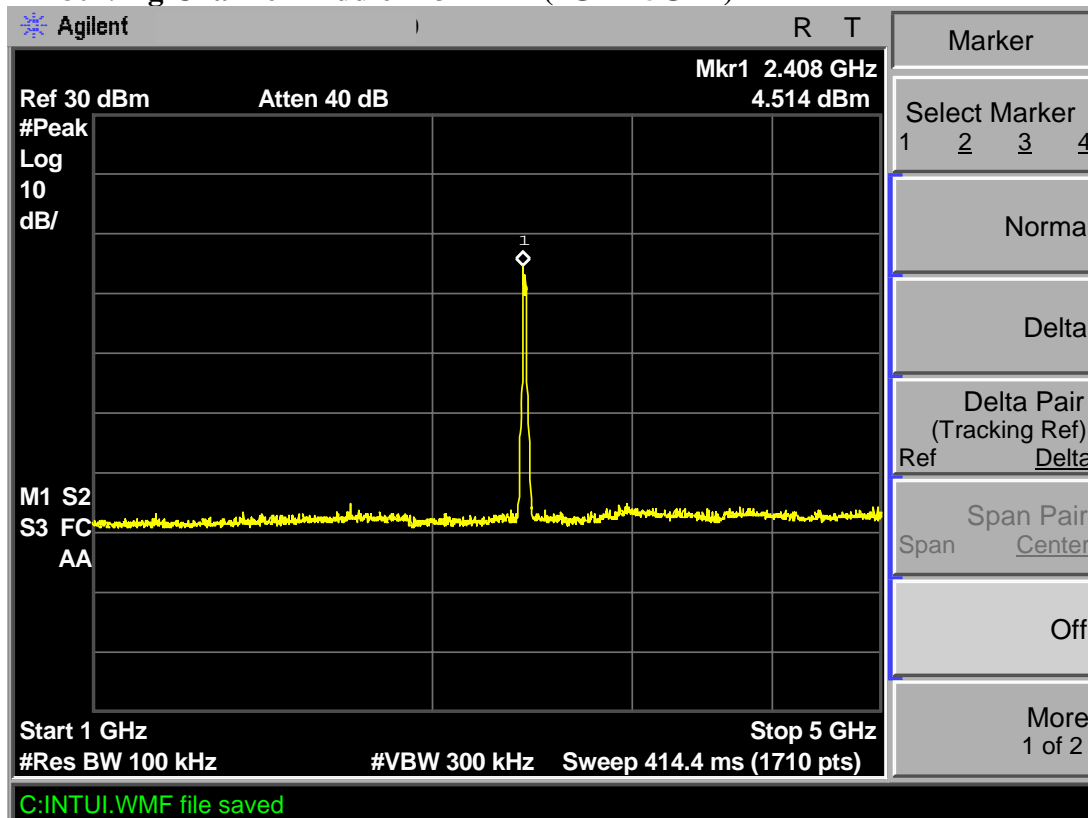

**TX 802.11g Channel Middle 2437MHz (5GHz-10GHz)**

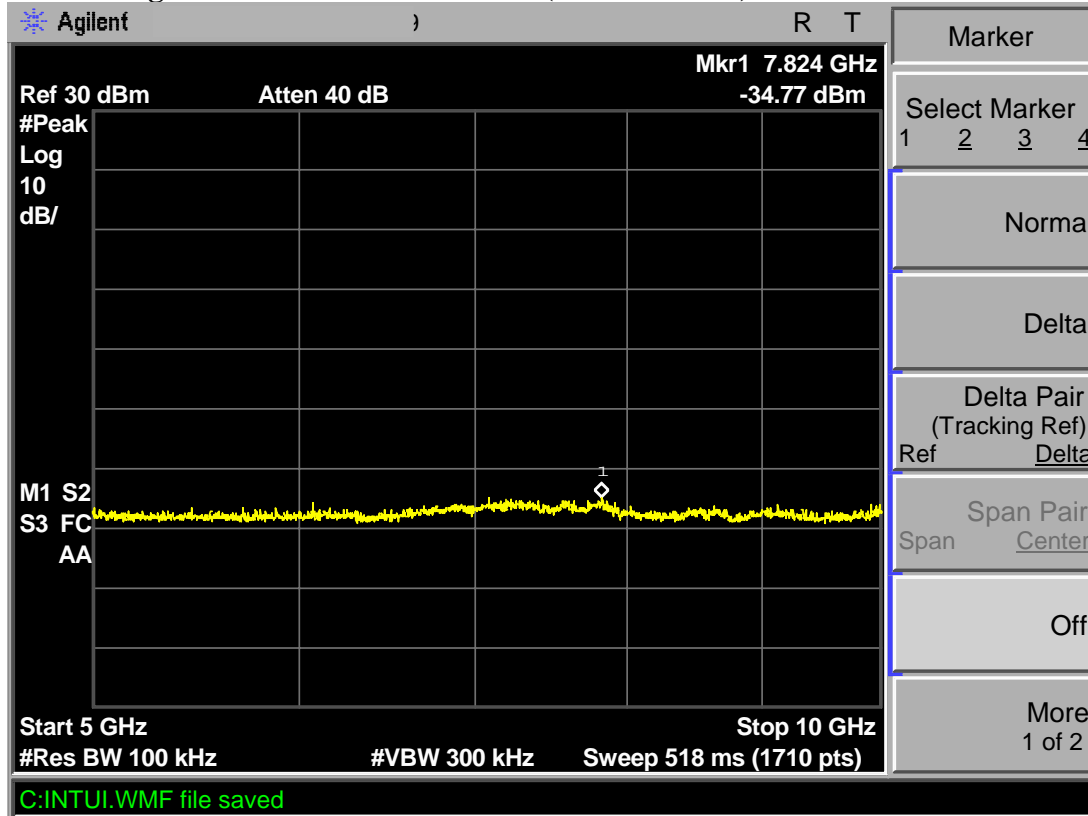

**TX 802.11g Channel Middle 2437MHz (10GHz-15GHz)**

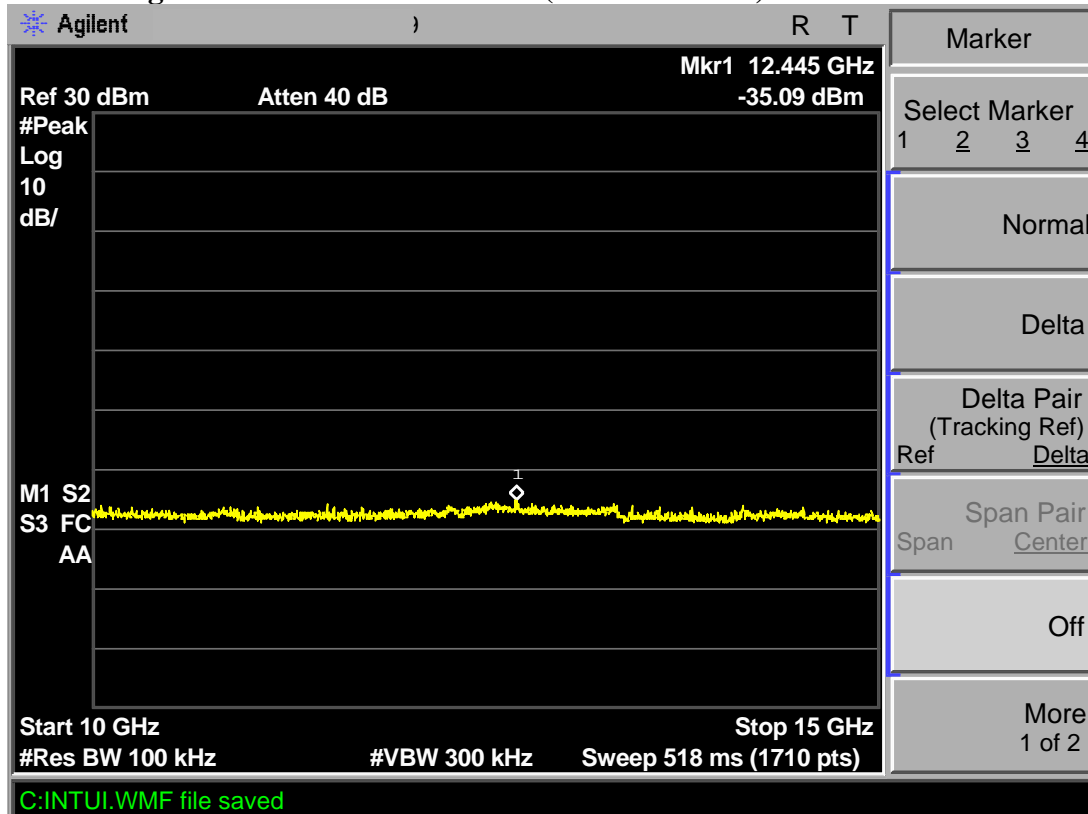

**TX 802.11g Channel Middle 2437MHz (15GHz-20GHz)**

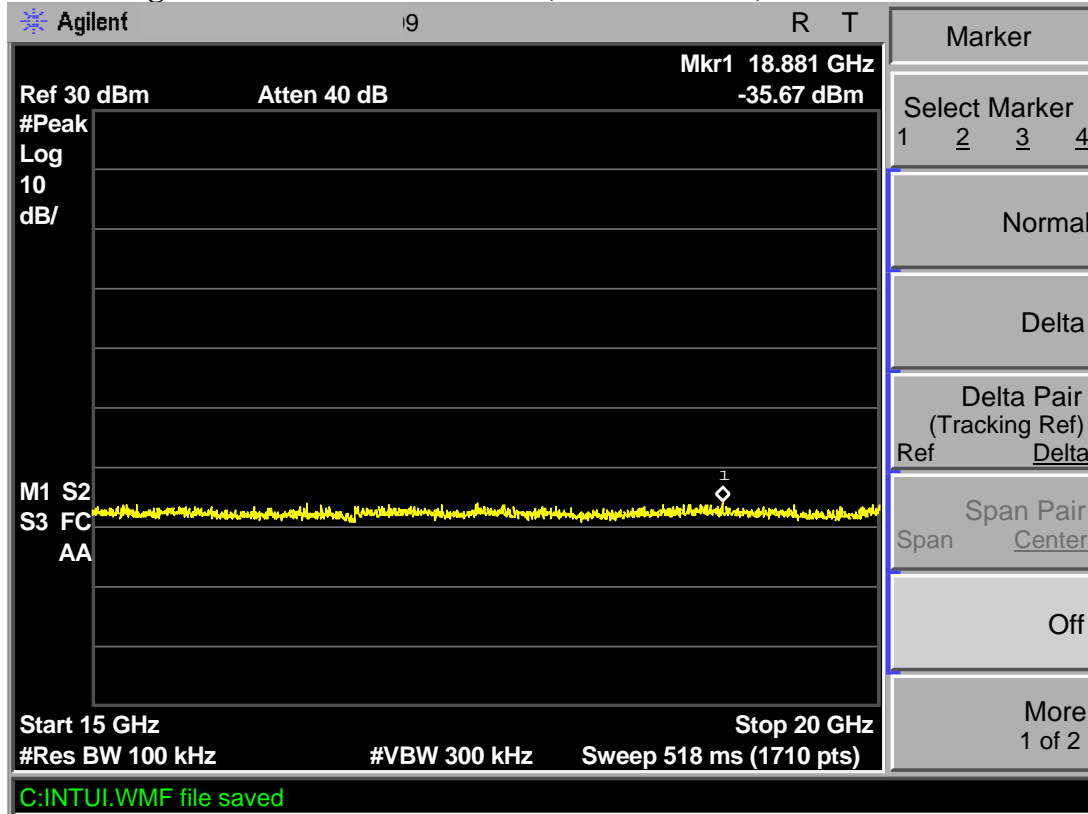

**TX 802.11g Channel Middle 2437MHz (20GHz-25GHz)**

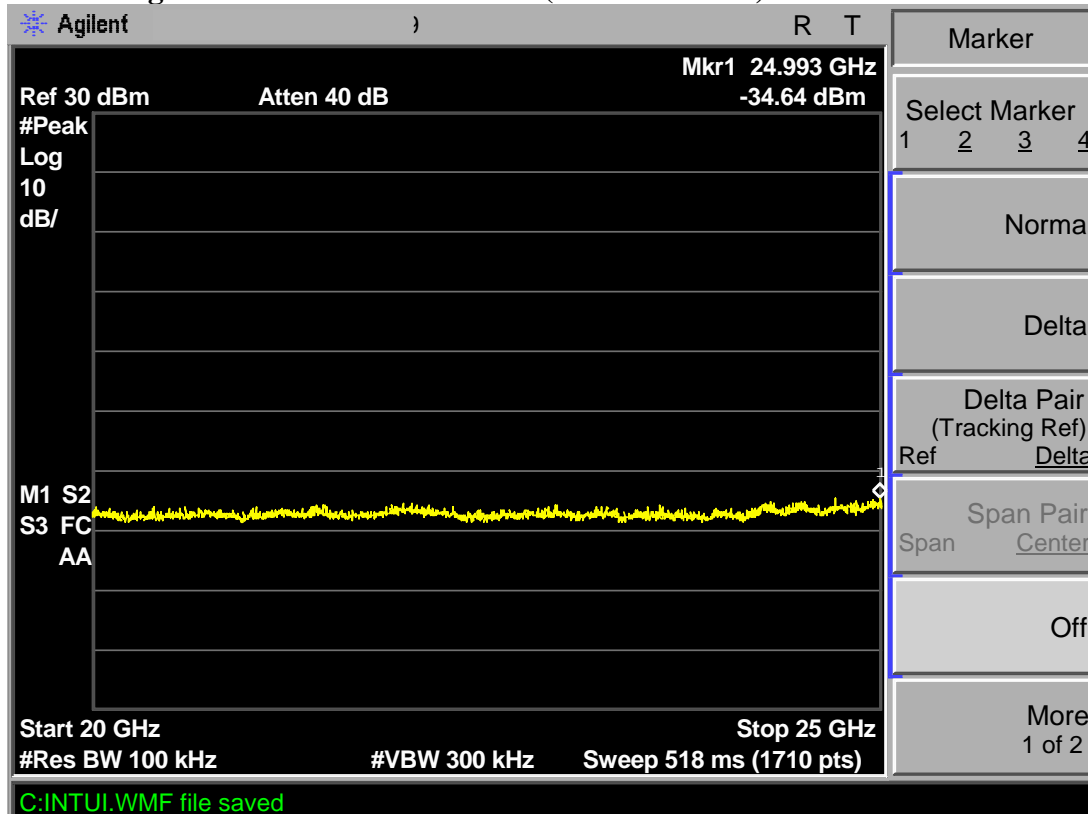

**TX 802.11g Channel High 2462MHz (30MHz-1GHz)**

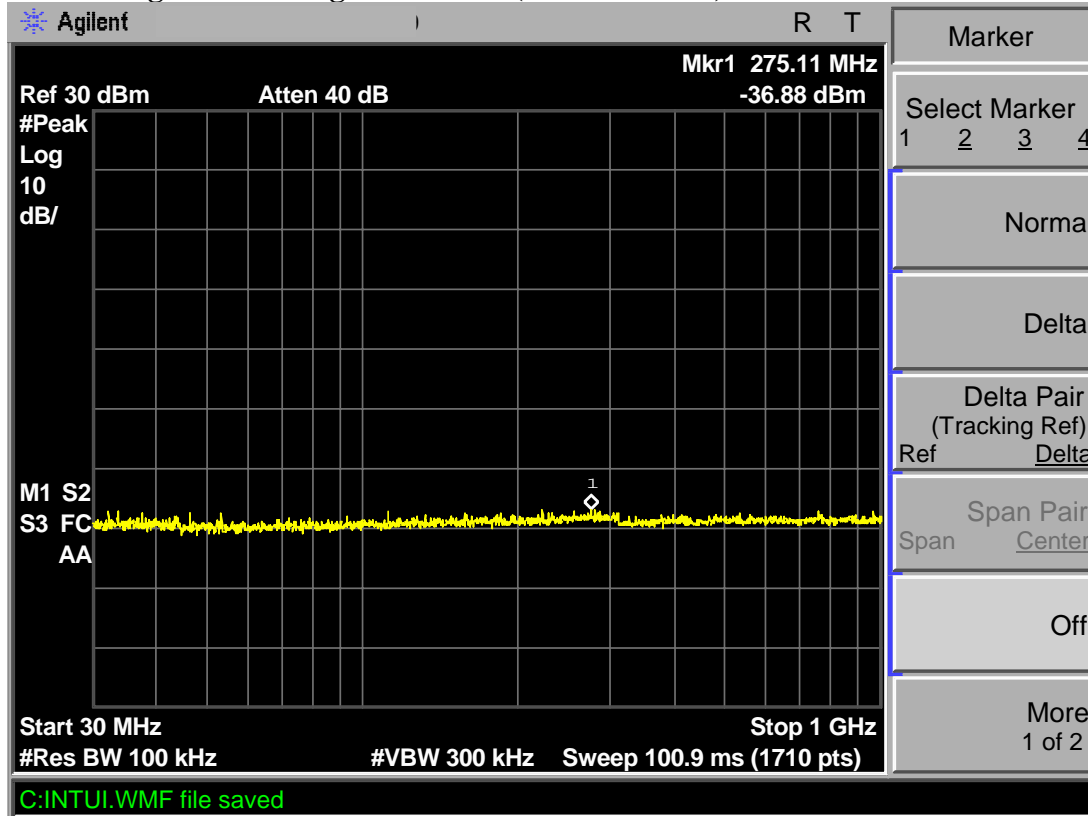

**TX 802.11g Channel High 2462MHz (1GHz-5GHz)**

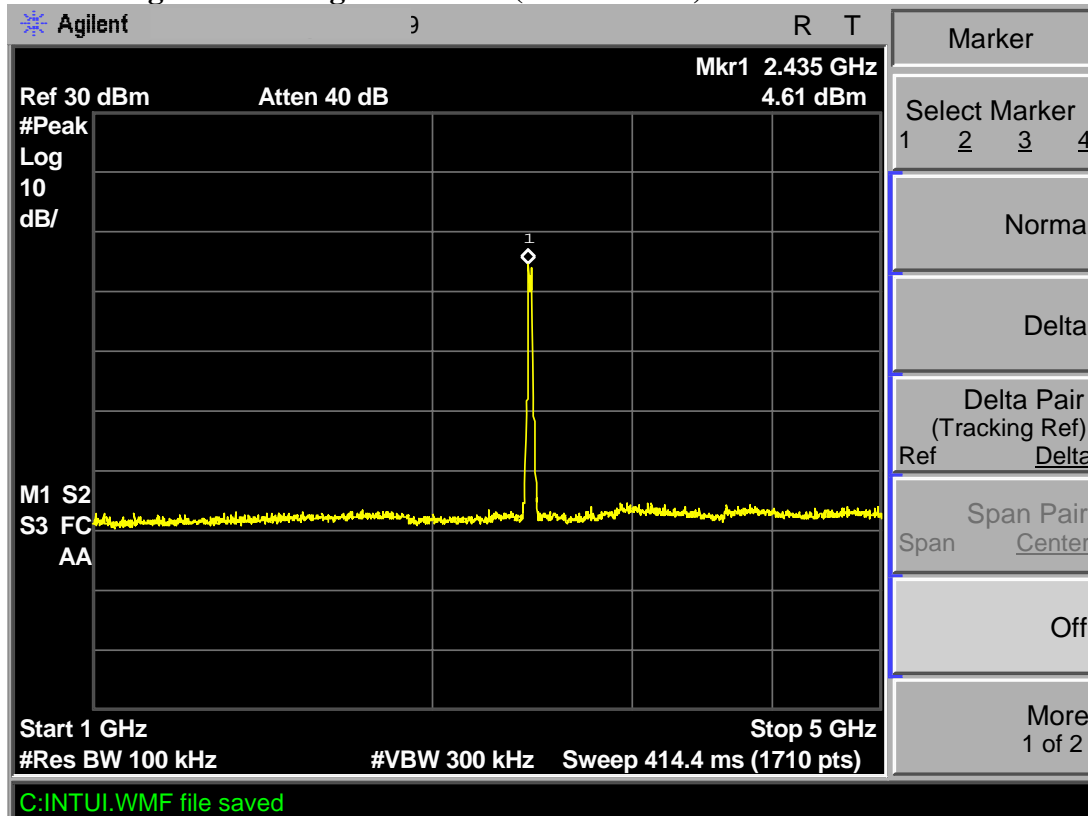

**TX 802.11g Channel High 2462MHz (5GHz-10GHz)**

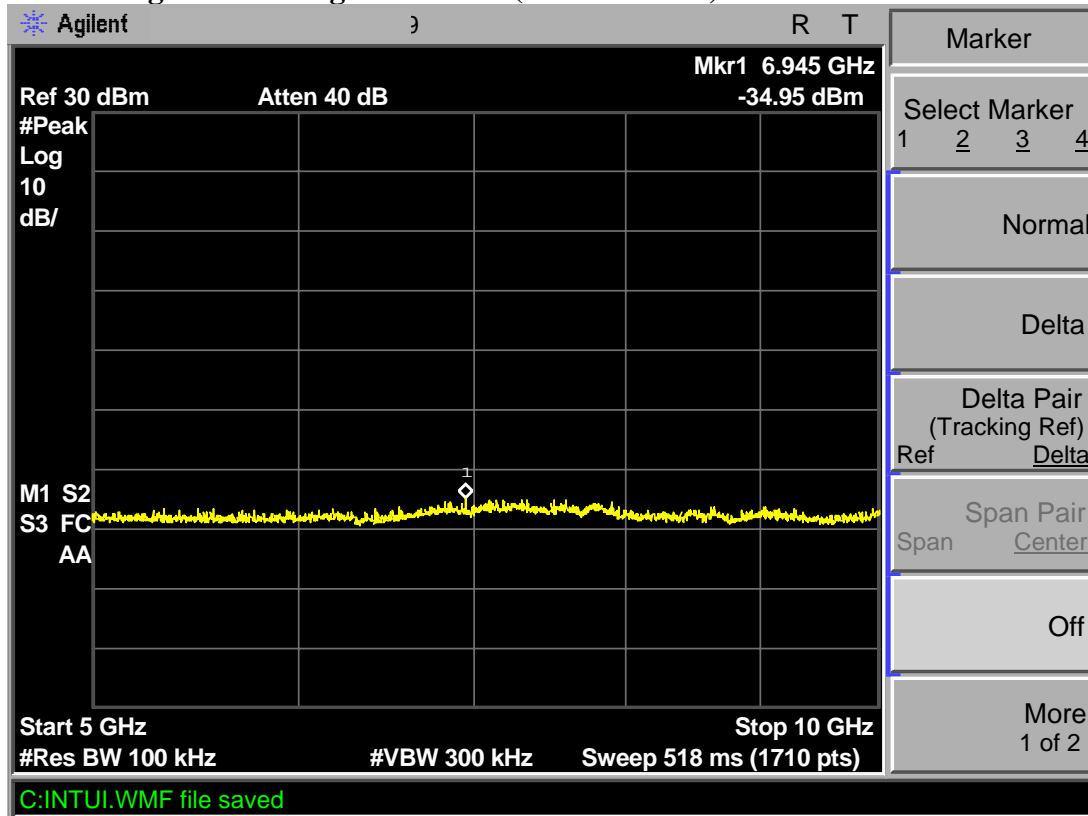

**TX 802.11g Channel High 2462MHz (10GHz-15GHz)**

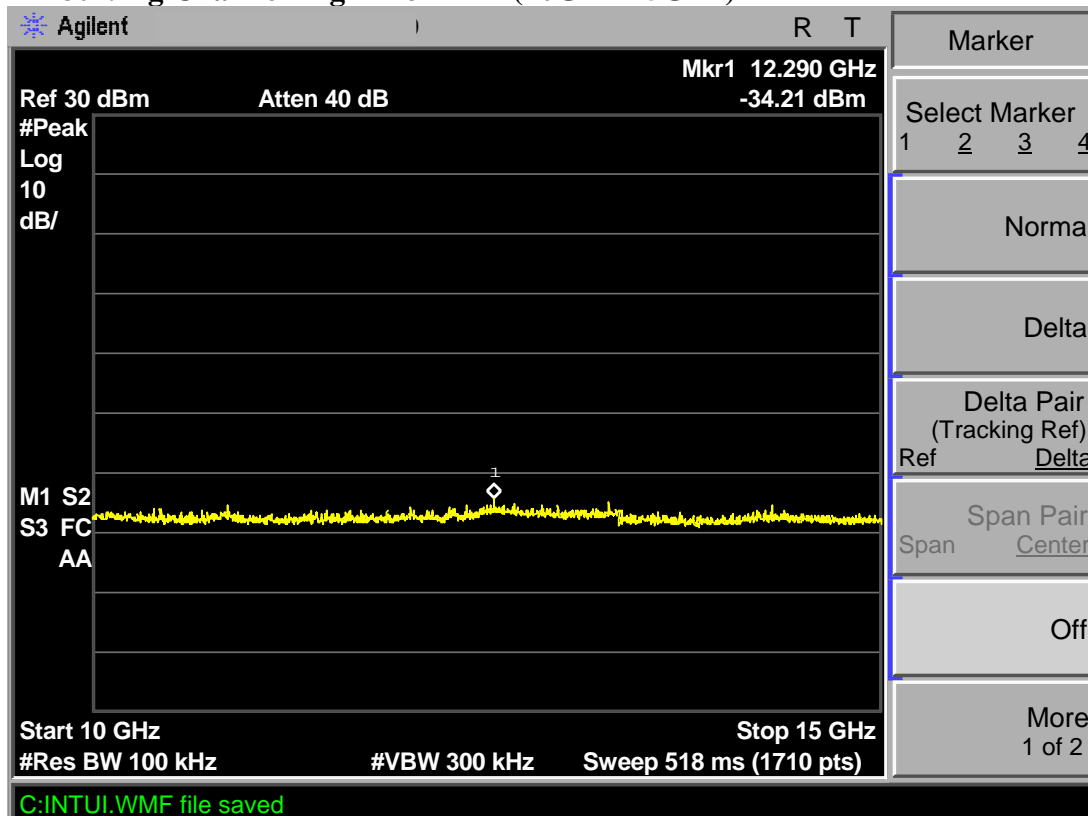



**TX 802.11g Channel High 2462MHz (15GHz-20GHz)**

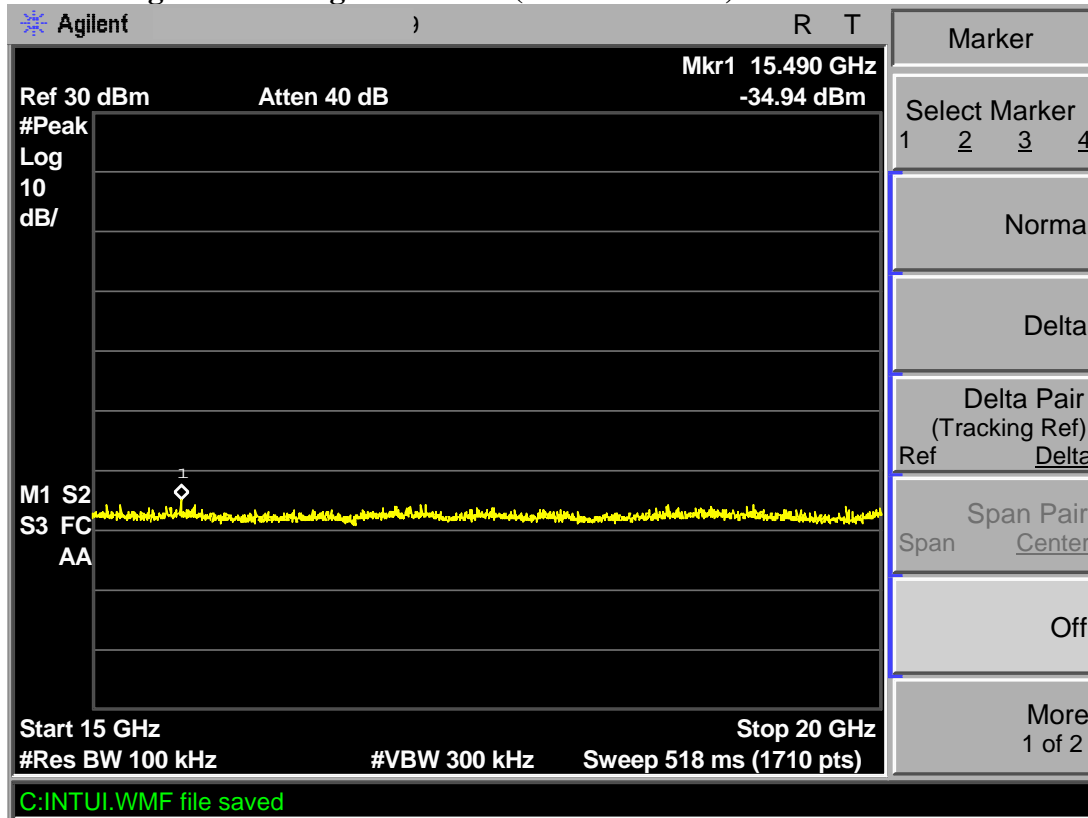

**TX 802.11g Channel High 2462MHz (20GHz-25GHz)**

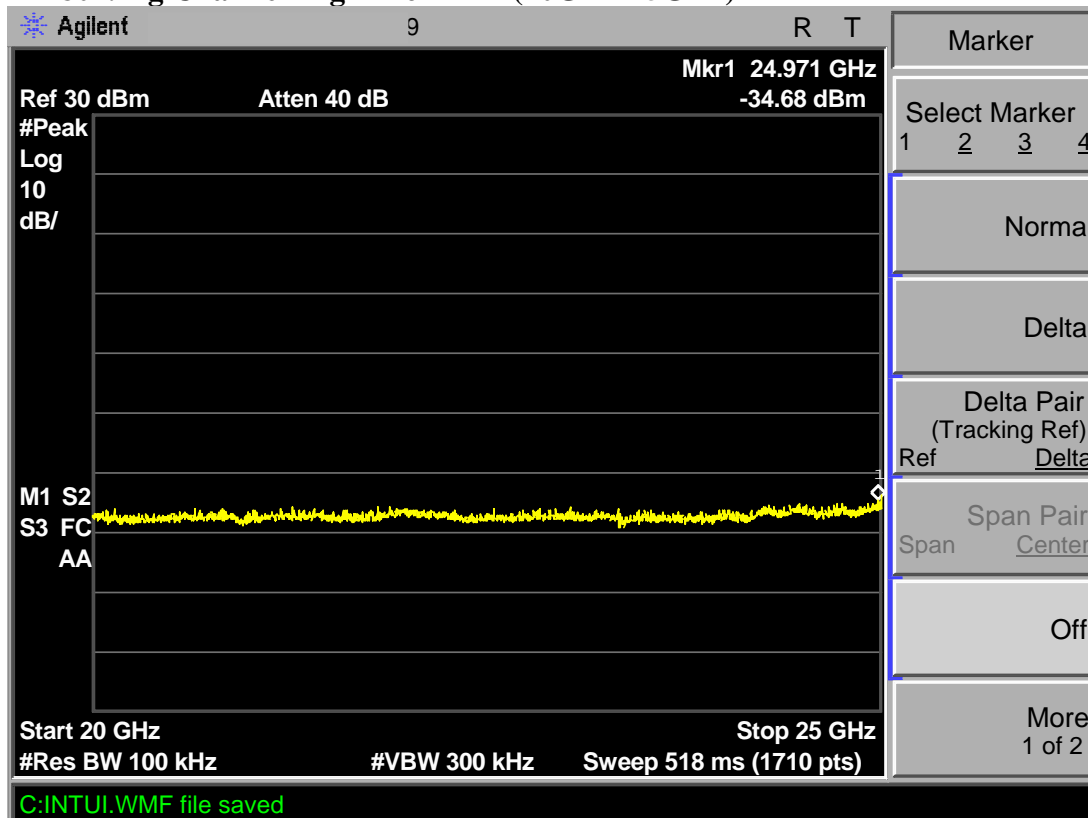

# 11.AC POWER LINE CONDUCTED EMISSION FOR FCC PART

## 15 SECTION 15.207(A)

### 11.1.Block Diagram of Test Setup

#### 11.1.1.Block diagram of connection between the EUT and simulators

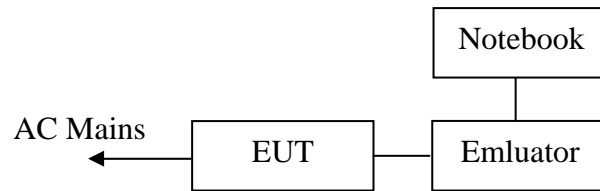

(EUT: GuruPlug)

#### 11.1.2.Shielding Room Test Setup Diagram

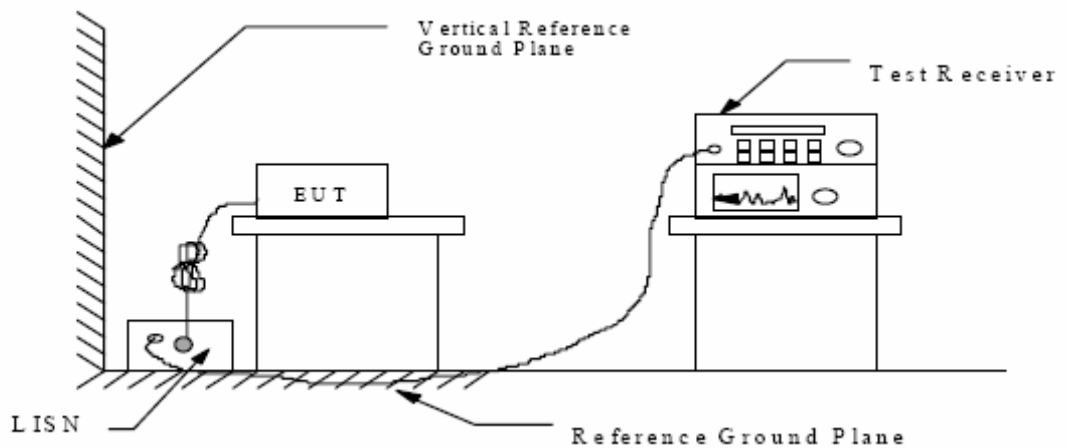

(EUT: GuruPlug)

### 11.2.The Emission Limit

#### 11.2.1.Conducted Emission Measurement Limits According to Section 15.207(a)

Frequency (MHz)	Limit dB(μV)	
	Quasi-peak Level	Average Level
0.15 - 0.50	66.0 - 56.0 *	56.0 - 46.0 *
0.50 - 5.00	56.0	46.0
5.00 - 30.00	60.0	50.0

\* Decreases with the logarithm of the frequency.

### 11.3. Configuration of EUT on Measurement

The following equipment are installed on the Conducted Emission Measurement to meet the commission requirements and operating regulations in a manner which tends to maximize its emission characteristics in normal application.

#### 11.3.1. GuruPlug (EUT)

Model Number : 003-GP11A101  
Serial Number : N/A  
Manufacturer : Globalscale Technologies INC

### 11.4. Operating Condition of EUT

11.4.1. Setup the EUT and simulator as shown as Section 11.1.

11.4.2. Turn on the power of all equipment.

11.4.3. Let the EUT work in TX (802.11b Channel Middle, 802.11g Channel Middle) mode measure it.

### 11.5. Test Procedure

The EUT is put on the plane 0.8m high above the ground by insulating support and is connected to the power mains through a line impedance stabilization network (L.I.S.N.). This provides a 50ohm coupling impedance for the EUT system. Please refer the block diagram of the test setup and photographs. Both sides of AC lines are checked to find out the maximum conducted emission. In order to find the maximum emission levels, the relative positions of equipment and all of the interface cables shall be changed according to ANSI C63.4: 2003 on Conducted Emission Measurement.

The bandwidth of test receiver (R & S ESCS30) is set at 9kHz.

The frequency range from 150kHz to 30MHz is checked.

## 11.6. Power Line Conducted Emission Measurement Results

### PASS.

The frequency range from 150kHz to 30MHz is checked.

Date of Test:	<u>April 15, 2010</u>	Temperature:	<u>25°C</u>
EUT:	<u>GuruPlug</u>	Humidity:	<u>50%</u>
Model No.:	<u>003-GP11A101</u>	Power Supply:	<u>AC 120V/ 60Hz</u>
Test Mode:	<u>TX 802.11b Channel Middle</u>	Test Engineer:	<u>Joe</u>

Frequency (MHz)	Result (dB $\mu$ V)	Limit (dB $\mu$ V)	Margin (dB)	Detector	Line
0.153629	45.10	66	20.7	QP	Neutral
1.200301	35.90	56	20.1	QP	
8.388030	30.30	60	29.7	QP	
0.465036	27.00	47	19.6	AV	
1.200301	34.50	46	11.5	AV	
8.255415	25.60	50	24.4	AV	
0.152410	46.40	66	19.5	QP	Live
1.209903	34.30	56	21.7	QP	
2.420009	29.60	56	26.4	QP	
0.468757	29.20	47	17.3	AV	
1.209903	33.50	46	12.5	AV	
2.420009	23.70	46	22.3	AV	

Emissions attenuated more than 20 dB below the permissible value are not reported.  
The spectral diagrams are attached as below.

Date of Test:	<u>April 16, 2010</u>	Temperature:	<u>25°C</u>
EUT:	<u>GuruPlug</u>	Humidity:	<u>50%</u>
Model No.:	<u>003-GP11A101</u>	Power Supply:	<u>AC 120V/ 60Hz</u>
Test Mode:	<u>TX 802.11g Channel Middle</u>	Test Engineer:	<u>Joe</u>

Frequency (MHz)	Result (dBμV)	Limit (dBμV)	Margin (dB)	Detector	Line
0.171759	47.90	65	17.0	QP	Neutral
0.476287	34.20	56	22.2	QP	
1.209903	36.90	56	19.1	QP	
0.173133	33.30	55	21.5	AV	
0.487809	24.60	46	21.6	AV	
1.209903	36.30	46	9.7	AV	
0.169044	47.00	65	18.0	QP	Live
0.472507	35.50	57	21.0	QP	
1.209903	34.90	56	21.1	QP	
0.175915	34.00	55	20.7	AV	
0.480097	27.50	46	18.8	AV	
1.209903	34.70	46	11.3	AV	

Emissions attenuated more than 20 dB below the permissible value are not reported.  
The spectral diagrams are attached as below.

ACCURATE TECHNOLOGY CO., LTD

CONDUCTED EMISSION STANDARD FCC PART 15 B

EUT: GuruPlug M/N:003-GP11A101  
 Manufacturer: Globalscale Technologies INC  
 Operating Condition: TX Channel 6 (802.11b)  
 Test Site: 1#Shielding Room  
 Operator: Joe  
 Test Specification: L 120V/60Hz  
 Comment: Sample No.:100743 Report No.:ATE20100630  
 Start of Test: 4/15/2010 / 1:59:40PM

SCAN TABLE: "V 150K-30MHz fin"

Short Description: \_SUB\_STD\_VTERM2 1.70

Start	Stop	Step	Detector	Meas. Time	IF Bandw.	Transducer
150.0 kHz	30.0 MHz	0.8 %	QuasiPeak	1.0 s	9 kHz	NSLK8126 2008
Average						

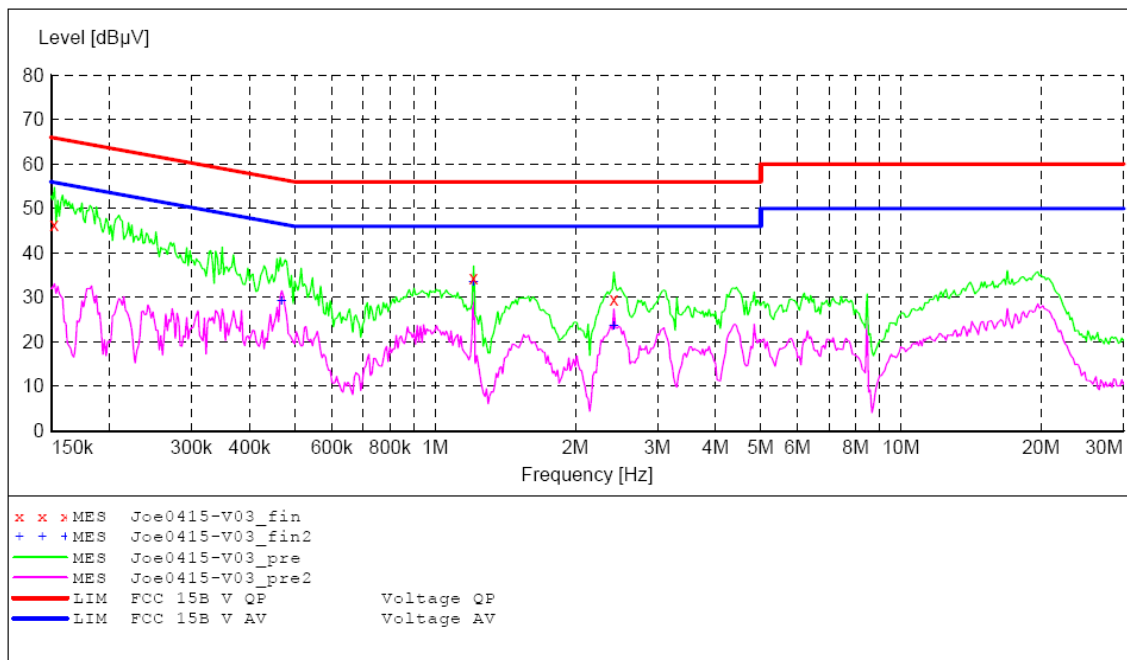

MEASUREMENT RESULT: "Joe0415-V03\_fin"

4/15/2010 2:02PM

Frequency MHz	Level dBµV	Transd dB	Limit dBµV	Margin dB	Detector	Line	PE
0.152410	46.40	11.0	66	19.5	QP	L1	GND
1.209903	34.30	11.8	56	21.7	QP	L1	GND
2.420009	29.60	11.6	56	26.4	QP	L1	GND

MEASUREMENT RESULT: "Joe0415-V03\_fin2"

4/15/2010 2:02PM

Frequency MHz	Level dBµV	Transd dB	Limit dBµV	Margin dB	Detector	Line	PE
0.468757	29.20	11.9	47	17.3	AV	L1	GND
1.209903	33.50	11.8	46	12.5	AV	L1	GND
2.420009	23.70	11.6	46	22.3	AV	L1	GND

ACCURATE TECHNOLOGY CO., LTD

CONDUCTED EMISSION STANDARD FCC PART 15 B

EUT: GuruPlug M/N:003-GP11A101  
 Manufacturer: Globalscale Technologies INC  
 Operating Condition: TX Channel 6 (802.11b)  
 Test Site: 1#Shielding Room  
 Operator: Joe  
 Test Specification: N 120V/60Hz  
 Comment: Sample No.:100743 Report No.:ATE20100630  
 Start of Test: 4/15/2010 / 2:03:10PM

SCAN TABLE: "V 150K-30MHz fin"

Start Frequency	Stop Frequency	Step Width	Detector	Meas. Time	IF Bandw.	Transducer
150.0 kHz	30.0 MHz	0.8 %	QuasiPeak	1.0 s	9 kHz	NSLK8126 2008
Average						

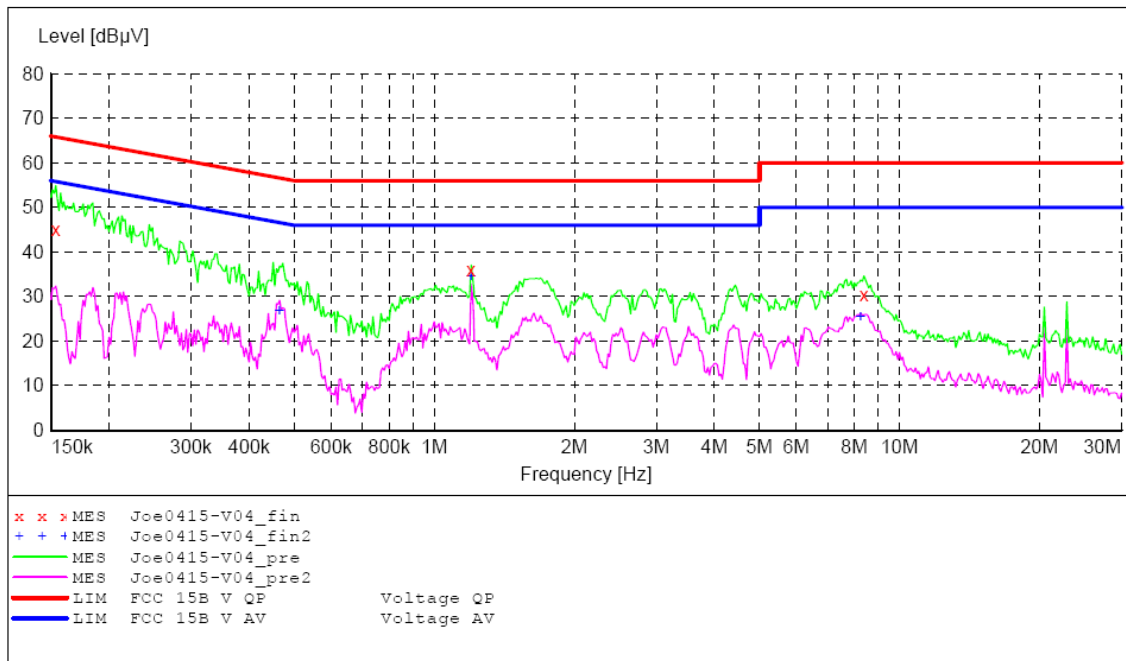

MEASUREMENT RESULT: "Joe0415-V04\_fin"

4/15/2010 2:05PM

Frequency MHz	Level dBµV	Transd dB	Limit dBµV	Margin dB	Detector	Line	PE
0.153629	45.10	11.0	66	20.7	QP	N	GND
1.200301	35.90	11.8	56	20.1	QP	N	GND
8.388030	30.30	11.3	60	29.7	QP	N	GND

MEASUREMENT RESULT: "Joe0415-V04\_fin2"

4/15/2010 2:05PM

Frequency MHz	Level dBµV	Transd dB	Limit dBµV	Margin dB	Detector	Line	PE
0.465036	27.00	11.9	47	19.6	AV	N	GND
1.200301	34.50	11.8	46	11.5	AV	N	GND
8.255415	25.60	11.3	50	24.4	AV	N	GND

ACCURATE TECHNOLOGY CO., LTD

CONDUCTED EMISSION STANDARD FCC PART 15 B

EUT: GuruPlug M/N:003-GP11A101  
 Manufacturer: Globalscale Technologies INC  
 Operating Condition: TX Channel 6 (802.11g)  
 Test Site: 1#Shielding Room  
 Operator: Joe  
 Test Specification: L 120V/60Hz  
 Comment: Sample No.:100743 Report No.:ATE20100630  
 Start of Test: 4/16/2010 / 11:44:01AM

SCAN TABLE: "V 150K-30MHz fin"

Short Description: \_SUB\_STD\_VTERM2 1.70  
 Start Stop Step Detector Meas. IF Transducer  
 Frequency Frequency Width Time Bandw.  
 150.0 kHz 30.0 MHz 0.8 % QuasiPeak 1.0 s 9 kHz NSLK8126 2008  
 Average

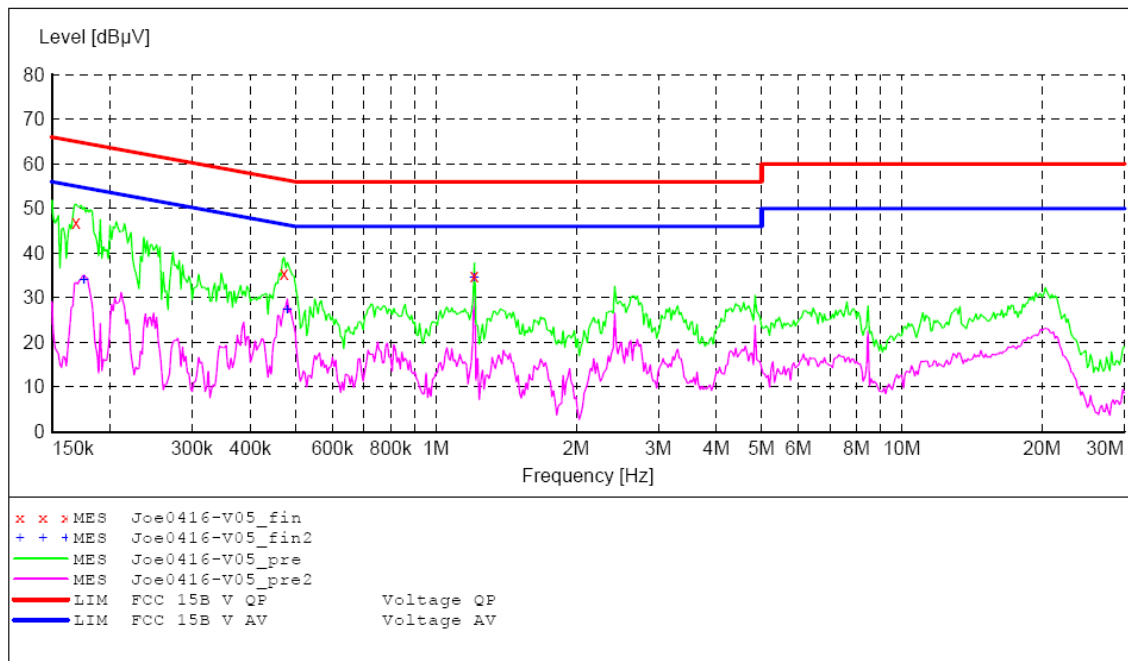

MEASUREMENT RESULT: "Joe0416-V05\_fin"

4/16/2010 11:46AM

Frequency MHz	Level dBµV	Transd dB	Limit dBµV	Margin dB	Detector	Line	PE
0.169044	47.00	11.1	65	18.0	QP	L1	GND
0.472507	35.50	12.0	57	21.0	QP	L1	GND
1.209903	34.90	11.8	56	21.1	QP	L1	GND

MEASUREMENT RESULT: "Joe0416-V05\_fin2"

4/16/2010 11:46AM

Frequency MHz	Level dBµV	Transd dB	Limit dBµV	Margin dB	Detector	Line	PE
0.175915	34.00	11.1	55	20.7	AV	L1	GND
0.480097	27.50	12.0	46	18.8	AV	L1	GND
1.209903	34.70	11.8	46	11.3	AV	L1	GND



**ACCURATE TECHNOLOGY CO., LTD**

**CONDUCTED EMISSION STANDARD FCC PART 15 B**

EUT: GuruPlug M/N:003-GP11A101  
 Manufacturer: Globalscale Technologies INC  
 Operating Condition: TX Channel 6 (802.11g)  
 Test Site: 1#Shielding Room  
 Operator: Joe  
 Test Specification: N 120V/60Hz  
 Comment: Sample No.:100743 Report No.:ATE20100630  
 Start of Test: 4/16/2010 / 11:42:17AM

**SCAN TABLE: "V 150K-30MHz fin"**

Short Description: \_SUB\_STD\_VTERM2 1.70  
 Start Stop Step Detector Meas. IF Transducer  
 Frequency Frequency Width Time Bandw.  
 150.0 kHz 30.0 MHz 0.8 % QuasiPeak 1.0 s 9 kHz NSLK8126 2008  
 Average

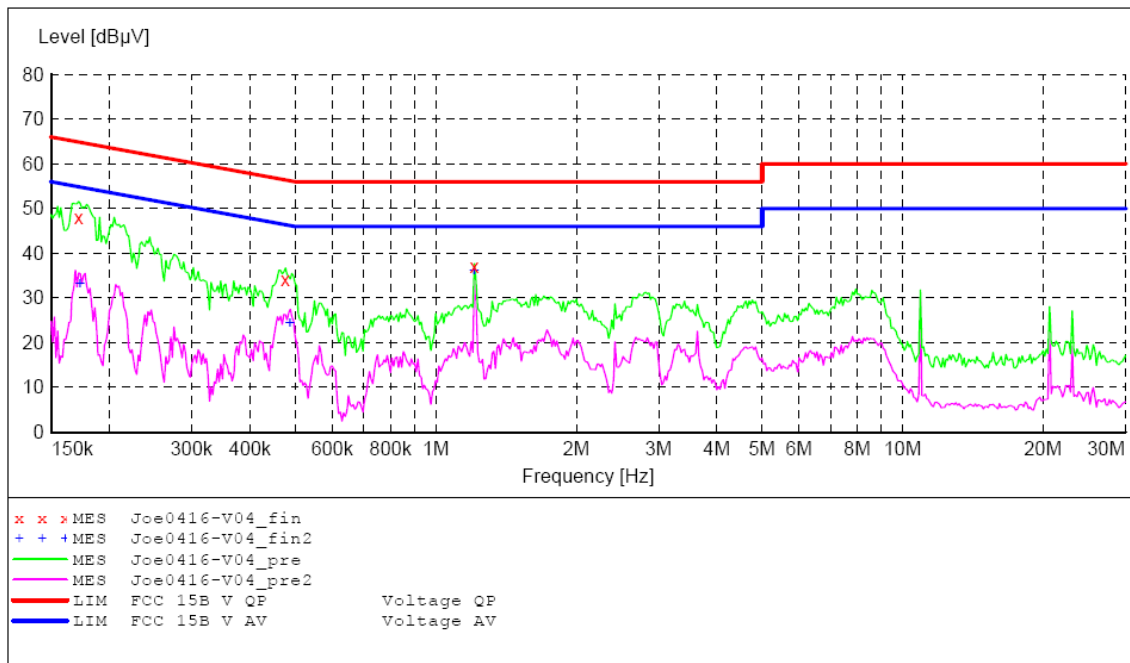

**MEASUREMENT RESULT: "Joe0416-V04\_fin"**

4/16/2010 11:43AM

Frequency MHz	Level dBµV	Transd dB	Limit dBµV	Margin dB	Detector	Line	PE
0.171759	47.90	11.1	65	17.0	QP	N	GND
0.476287	34.20	12.0	56	22.2	QP	N	GND
1.209903	36.90	11.8	56	19.1	QP	N	GND

**MEASUREMENT RESULT: "Joe0416-V04\_fin2"**

4/16/2010 11:43AM

Frequency MHz	Level dBµV	Transd dB	Limit dBµV	Margin dB	Detector	Line	PE
0.173133	33.30	11.1	55	21.5	AV	N	GND
0.487809	24.60	12.0	46	21.6	AV	N	GND
1.209903	36.30	11.8	46	9.7	AV	N	GND

## 12. ANTENNA REQUIREMENT

### 12.1. The Requirement

According to Section 15.203, an intentional radiator shall be designed to ensure that no antenna other than that furnished by the responsible party shall be used with the device.

### 12.2. Antenna Construction

The transmitter utilizes SMD chip antenna, no consideration of replacement. Therefore, the equipment complies with the antenna requirement of Section 15.203.

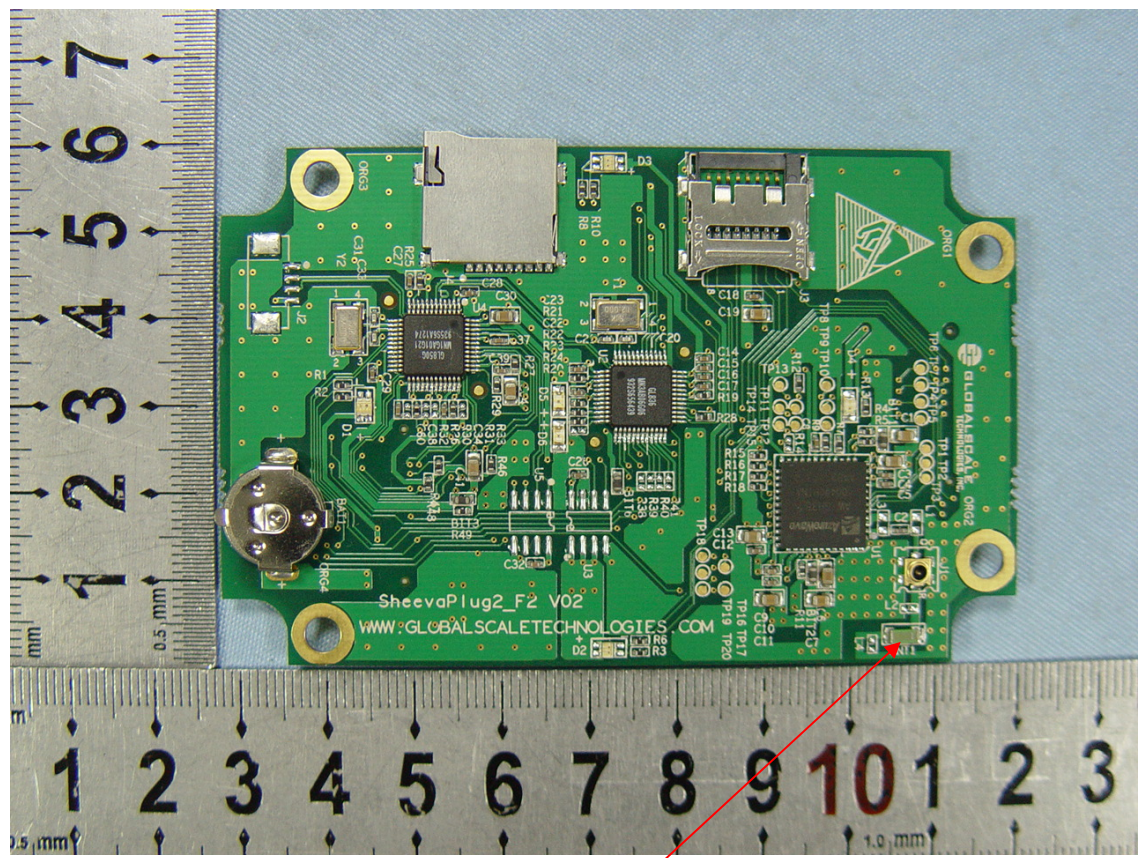

Antenna