



A D T

FCC TEST REPORT

REPORT NO.: RF990414E03

MODEL NO.: W150NU

RECEIVED: Apr. 14, 2010

TESTED: May 04 to 18, 2010

ISSUED: Aug. 18, 2010

APPLICANT: KEEBOX, Inc.

ADDRESS: P.O. Box 2290, Gardena, CA 90247 U.S.A.

ISSUED BY: Bureau Veritas Consumer Products Services (H.K.)
Ltd., Taoyuan Branch Hsin Chu Laboratory

LAB LOCATION: No. 81-1, Lu Liao Keng, 9th Ling,Wu Lung Tsuen,
Chiung Lin Hsiang, Hsin Chu Hsien 307, Taiwan

This test report consists of 75 pages in total. It may be duplicated completely for legal use with the approval of the applicant. It should not be reproduced except in full, without the written approval of our laboratory. The client should not use it to claim product endorsement by TAF or any government agencies. The test results in the report only apply to the tested sample.





Table of Contents

1.	CERTIFICATION	4
2.	SUMMARY OF TEST RESULTS	5
2.1	MEASUREMENT UNCERTAINTY	6
3.	GENERAL INFORMATION.....	7
3.1	GENERAL DESCRIPTION OF EUT	7
3.2	DESCRIPTION OF TEST MODES	9
3.2.1	TEST MODE APPLICABILITY AND TESTED CHANNEL DETAIL	10
3.3	GENERAL DESCRIPTION OF APPLIED STANDARDS	12
3.4	DESCRIPTION OF SUPPORT UNITS.....	13
3.5	CONFIGURATION OF SYSTEM UNDER TEST	13
4.	TEST TYPES AND RESULTS	14
4.1	CONDUCTED EMISSION MEASUREMENT.....	14
4.1.1	LIMITS OF CONDUCTED EMISSION MEASUREMENT	14
4.1.2	TEST INSTRUMENTS	14
4.1.3	TEST PROCEDURES.....	15
4.1.4	DEVIATION FROM TEST STANDARD	15
4.1.5	TEST SETUP	16
4.1.6	EUT OPERATING CONDITIONS	16
4.1.7	TEST RESULTS	17
4.2	RADIATED EMISSION MEASUREMENT	19
4.2.1	LIMITS OF RADIATED EMISSION MEASUREMENT.....	19
4.2.2	TEST INSTRUMENTS	20
4.2.3	TEST PROCEDURES.....	21
4.2.4	DEVIATION FROM TEST STANDARD	21
4.2.5	TEST SETUP	22
4.2.6	EUT OPERATING CONDITIONS	22
4.2.7	TEST RESULTS	23
4.3	6dB BANDWIDTH MEASUREMENT	52
4.3.1	LIMITS OF 6dB BANDWIDTH MEASUREMENT.....	52
4.3.2	TEST INSTRUMENTS	52
4.3.3	TEST PROCEDURE.....	52
4.3.4	DEVIATION FROM TEST STANDARD	52
4.3.5	TEST SETUP	52
4.3.6	EUT OPERATING CONDITIONS	52
4.3.7	TEST RESULTS	53
4.4	MAXIMUM PEAK OUTPUT POWER.....	57
4.4.1	LIMITS OF MAXIMUM PEAK OUTPUT POWER MEASUREMENT	57
4.4.2	INSTRUMENTS.....	57
4.4.3	TEST PROCEDURES.....	57
4.4.4	DEVIATION FROM TEST STANDARD	57



A D T

4.4.5	TEST SETUP	57
4.4.6	EUT OPERATING CONDITIONS	57
4.4.7	TEST RESULTS	58
4.5	POWER SPECTRAL DENSITY MEASUREMENT.....	60
4.5.1	LIMITS OF POWER SPECTRAL DENSITY MEASUREMENT	60
4.5.2	TEST INSTRUMENTS	60
4.5.3	TEST PROCEDURE	60
4.5.4	DEVIATION FROM TEST STANDARD	60
4.5.5	TEST SETUP	60
4.5.6	EUT OPERATING CONDITION.....	60
4.5.7	TEST RESULTS	61
4.6	CONDUCTED OUT-BAND EMISSION MEASUREMENT	65
4.6.1	LIMITS OF CONDUCTED OUT-BAND EMISSION MEASUREMENT.....	65
4.6.2	TEST INSTRUMENTS	65
4.6.3	TEST PROCEDURE	65
4.6.4	DEVIATION FROM TEST STANDARD	65
4.6.5	EUT OPERATING CONDITION.....	65
4.6.6	TEST RESULTS	65
5.	INFORMATION ON THE TESTING LABORATORIES	74
6.	APPENDIX A - MODIFICATIONS RECORDERS FOR ENGINEERING CHANGES TO THE EUT BY THE LAB	75



1. CERTIFICATION

PRODUCT: Wireless N 150 USB Adapter
BRAND NAME: KEEBOX
MODEL NO.: W150NU
TEST SAMPLE: MASS-PRODUCTION
TESTED: May 04 to 18, 2010
APPLICANT: KEEBOX, Inc.
STANDARDS: FCC Part 15, Subpart C (Section 15.247)
ANSI C63.4-2003

The above equipment (Model: W150NU) has been tested by **Bureau Veritas Consumer Products Services (H.K.) Ltd., Taoyuan Branch**, and found compliance with the requirement of the above standards. The test record, data evaluation & Equipment Under Test (EUT) configurations represented herein are true and accurate accounts of the measurements of the sample's EMC characteristics under the conditions specified in this report.

PREPARED BY : Carol Liao , **DATE:** Aug 18, 2010
(Carol Liao, Specialist)

TECHNICAL ACCEPTANCE : Hank Chung , **DATE:** Aug 18, 2010
(Hank Chung, Deputy Manager)

APPROVED BY : May Chen , **DATE:** Aug 18, 2010
(May Chen, Deputy Manager)



A D T

2. SUMMARY OF TEST RESULTS

The EUT has been tested according to the following specifications:

APPLIED STANDARD: FCC Part 15, Subpart C			
Standard Section	Test Type and Limit	Result	Remark
15.207	AC Power Conducted Emission	PASS	Meet the requirement of limit. Minimum passing margin is -11.46dB at 3.742MHz
15.247(a)(2)	Spectrum Bandwidth of a Direct Sequence Spread Spectrum System Limit: min. 500kHz	PASS	Meet the requirement of limit.
15.247(b)	Maximum Peak Output Power Limit: max. 30dBm	PASS	Meet the requirement of limit.
15.247(d)	Radiated Emissions Limit: Table 15.209	PASS	Meet the requirement of limit. Minimum passing margin is -1.3dB at 4924.00MHz
15.247(e)	Power Spectral Density Limit: max. 8dBm	PASS	Meet the requirement of limit.
15.247(d)	Conducted Out-Band Emission Measurement Limit: 20dB less than the peak value of fundamental frequency	PASS	Meet the requirement of limit.
15.203	Antenna Requirement	PASS	No antenna connector is used.

2.1 MEASUREMENT UNCERTAINTY

Where relevant, the following measurement uncertainty levels have been estimated for tests performed on the EUT as specified in CISPR 16-4-2:

This uncertainty represents an expanded uncertainty expressed at approximately the 95% confidence level using a coverage factor of $k=2$.

Measurement	Value
Conducted emissions	2.45 dB
Radiated emissions (30MHz-1GHz)	3.94 dB
Radiated emissions (1GHz -18GHz)	2.49 dB
Radiated emissions (18GHz -40GHz)	2.70 dB



A D T

3. GENERAL INFORMATION

3.1 GENERAL DESCRIPTION OF EUT

PRODUCT	Wireless N 150 USB Adapter
MODEL NO.	W150NU
FCC ID	YC3W150NU
POWER SUPPLY	DC 5V±10% from host equipment
MODULATION TYPE	CCK, DQPSK, DBPSK for DSSS 64QAM, 16QAM, QPSK, BPSK for OFDM
MODULATION TECHNOLOGY	DSSS, OFDM
TRANSFER RATE	802.11b:11/5.5/2/1Mbps 802.11g: 54/48/36/24/18/12/9/6Mbps 802.11n (20MHz, 800ns GI): 65 / 58.5 / 52 / 39 / 26 / 19.5 / 13 / 6.5Mbps 802.11n (40MHz, 800ns GI): 135 / 121.5 / 108 / 81 / 54 / 40.5 / 27 / 13.5Mbps 802.11n (20MHz, 400ns GI): 72.2 / 65 / 57.8 / 43.3 / 28.9 / 21.7 / 14.4 / 7.2Mbps 802.11n (40MHz, 400ns GI): 150 / 135 / 120 / 90 / 60 / 45 / 30 / 15Mbps
FREQUENCY RANGE	2412MHz ~ 2462MHz
NUMBER OF CHANNEL	11 for 802.11b, 802.11g, 802.11n (20MHz) 7 for 802.11n (40MHz)
MAXIMUM OUTPUT POWER	802.11b: 117.5mW 802.11g: 436.5mW 802.11n (20MHz): 446.7mW 802.11n (40MHz): 457.1mW
ANTENNA TYPE	Please see note 1
DATA CABLE	NA
I/O PORTS	NA
ASSOCIATED DEVICES	NA

NOTE:

1. There is one antenna provided to this EUT, please refer to the following table:

Chain	Manufacture	Gain (dBi)	Antenna Type	Connector Type
Chain (0)	Alpha Networks Inc.	1.25	Printed Antenna	N/A

2. The EUT incorporates a SISO function with 802.11b, 802.11g, 802.11n. Physically, the EUT provides one completed transmitter and one receiver.
3. The EUT is 1 * 1 spatial SISO without beam forming function. The antenna configuration is one transmitter antenna and one receiver antenna, as there is 1 Printed antenna.
4. The EUT complies with 802.11n standards and backwards compatible with 802.11b, 802.11g products.
5. The EUT, operates in the 2.4GHz frequency range, lets you connect IEEE 802.11g or IEEE 802.11b and 802.11n technique devices to the network.
6. The above EUT information was declared by the manufacturer and for more detailed features description, please refer to the manufacturer's specifications or User's Manual.

3.2 DESCRIPTION OF TEST MODES

Eleven channels are provided for 802.11b, 802.11g, 802.11n (20MHz):

CHANNEL	FREQUENCY	CHANNEL	FREQUENCY
1	2412MHz	7	2442MHz
2	2417MHz	8	2447MHz
3	2422MHz	9	2452MHz
4	2427MHz	10	2457MHz
5	2432MHz	11	2462MHz
6	2437MHz		

Seven channels are provided for 802.11n (40MHz):

CHANNEL	FREQUENCY	CHANNEL	FREQUENCY
1	2422MHz	5	2442MHz
2	2427MHz	6	2447MHz
3	2432MHz	7	2452MHz
4	2437MHz		

3.2.1 TEST MODE APPLICABILITY AND TESTED CHANNEL DETAIL

EUT CONFIGURE MODE	APPLICABLE TO				DESCRIPTION
	PLC	RE < 1G	RE ≥ 1G	APCM	
-	√	√	√	√	-

Where **PLC**: Power Line Conducted Emission **RE < 1G**: Radiated Emission below 1GHz
RE ≥ 1G: Radiated Emission above 1GHz **APCM**: Antenna Port Conducted Measurement

POWER LINE CONDUCTED EMISSION TEST:

- Pre-Scan has been conducted to determine the worst-case mode from all possible combinations between available modulations, data rates and antenna ports (if EUT with antenna diversity architecture).
- Following channel(s) was (were) selected for the final test as listed below.

MODE	AVAILABLE CHANNEL	TESTED CHANNEL	MODULATION TECHNOLOGY	MODULATION TYPE	DATA RATE (Mbps)
802.11n (40MHz)	1 to 7	7	OFDM	BPSK	13.5

RADIATED EMISSION TEST (BELOW 1 GHz):

- Pre-Scan has been conducted to determine the worst-case mode from all possible combinations between available modulations, data rates and antenna ports (if EUT with antenna diversity architecture).
- Following channel(s) was (were) selected for the final test as listed below.

MODE	AVAILABLE CHANNEL	TESTED CHANNEL	MODULATION TECHNOLOGY	MODULATION TYPE	DATA RATE (Mbps)
802.11n (40MHz)	1 to 7	7	OFDM	BPSK	13.5

RADIATED EMISSION TEST (ABOVE 1 GHz):

- Pre-Scan has been conducted to determine the worst-case mode from all possible combinations between available modulations, data rates and antenna ports (if EUT with antenna diversity architecture).
- Following channel(s) was (were) selected for the final test as listed below.

MODE	AVAILABLE CHANNEL	TESTED CHANNEL	MODULATION TECHNOLOGY	MODULATION TYPE	DATA RATE (Mbps)
802.11b	1 to 11	1, 6, 11	DSSS	DBPSK	1
802.11g	1 to 11	1, 6, 11	OFDM	BPSK	6
802.11n (20MHz)	1 to 11	1, 6, 11	OFDM	BPSK	6.5
802.11n (40MHz)	1 to 7	1, 4, 7	OFDM	BPSK	13.5



CONDUCTED OUT-BAND EMISSION MEASUREMENT:

- Pre-Scan has been conducted to determine the worst-case mode from all possible combinations between available modulations, data rates and antenna ports (if EUT with antenna diversity architecture).
- Following channel(s) was (were) selected for the final test as listed below.

MODE	AVAILABLE CHANNEL	TESTED CHANNEL	MODULATION TECHNOLOGY	MODULATION TYPE	DATA RATE (Mbps)
802.11b	1 to 11	1, 11	DSSS	DBPSK	1
802.11g	1 to 11	1, 11	OFDM	BPSK	6
802.11n (20MHz)	1 to 11	1, 11	OFDM	BPSK	6.5
802.11n (40MHz)	1 to 7	1, 7	OFDM	BPSK	13.5

ANTENNA PORT CONDUCTED MEASUREMENT:

- This item includes all test value of each mode, but only includes spectrum plot of worst value of each mode.
- Pre-Scan has been conducted to determine the worst-case mode from all possible combinations between available modulations, data rates and antenna ports (if EUT with antenna diversity architecture).
- Following channel(s) was (were) selected for the final test as listed below.

MODE	AVAILABLE CHANNEL	TESTED CHANNEL	MODULATION TECHNOLOGY	MODULATION TYPE	DATA RATE (Mbps)
802.11b	1 to 11	1, 6, 11	DSSS	DBPSK	1
802.11g	1 to 11	1, 6, 11	OFDM	BPSK	6
802.11n (20MHz)	1 to 11	1, 6, 11	OFDM	BPSK	6.5
802.11n (40MHz)	1 to 7	1, 4, 7	OFDM	BPSK	13.5

※ TEST CONDITION:

APPLICABLE TO	ENVIRONMENTAL CONDITIONS	INPUT POWER (SYSTEM)	TESTED BY
RE ³ 1G	26deg. C, 67%RH, 1011 hPa	120Vac, 60Hz	Wen Yu
RE<1G	28deg. C, 60%RH, 1011 hPa	120Vac, 60Hz	Wen Yu
PLC	26deg. C, 68%RH, 1011 hPa	120Vac, 60Hz	Leo Peng
APCM	25deg. C, 60%RH, 1011 hPa	120Vac, 60Hz	Frank Liu

3.3 GENERAL DESCRIPTION OF APPLIED STANDARDS

The EUT is a RF product. According to the specifications of the manufacturer, it must comply with the requirements of the following standards:

FCC Part 15, Subpart C. (15.247)

ANSI C63.4-2003

All test items have been performed and recorded as per the above standards.

NOTE: The EUT has been verified to comply with the requirements of FCC Part 15, Subpart B, Class B (DoC). The test report has been issued separately.

3.4 DESCRIPTION OF SUPPORT UNITS

The EUT has been tested as an independent unit together with other necessary accessories or support units. The following support units or accessories were used to form a representative test configuration during the tests.

NO.	PRODUCT	BRAND	MODEL NO.	SERIAL NO.	FCC ID
1	NOTEBOOK COMPUTER	DELL	D531	CN-0XM006-48643-86L-4472	QDS-BRCM1019
2	iPod nano 2GB	APPLE	A1199	YM712NHFVQ5	FCC DoC

NO.	SIGNAL CABLE DESCRIPTION OF THE ABOVE SUPPORT UNITS
1	NA
2	1 m shielded cable, terminated with USB connector, w/o core.

NOTE: 1. All power cords of the above support units are non shielded (1.8m).

3.5 CONFIGURATION OF SYSTEM UNDER TEST

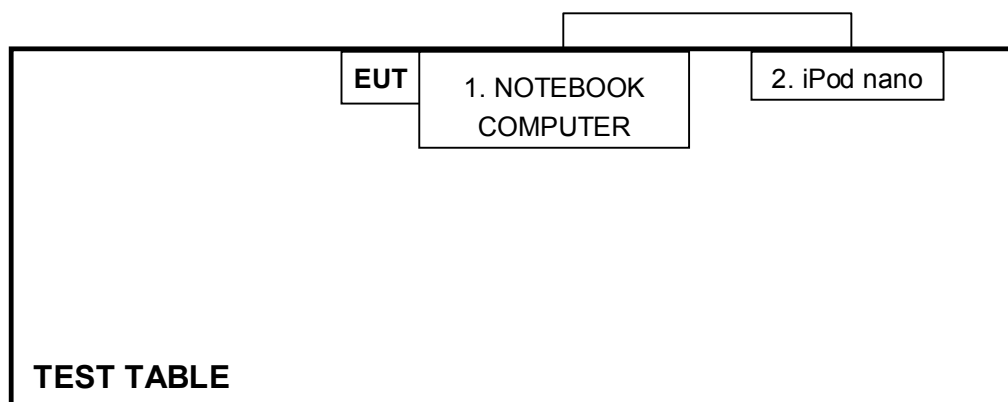



A D T

4. TEST TYPES AND RESULTS

4.1 CONDUCTED EMISSION MEASUREMENT

4.1.1 LIMITS OF CONDUCTED EMISSION MEASUREMENT

FREQUENCY OF EMISSION (MHz)	CONDUCTED LIMIT (dB μ V)	
	Quasi-peak	Average
0.15-0.5	66 to 56	56 to 46
0.5-5	56	46
5-30	60	50

- NOTE:**
1. The lower limit shall apply at the transition frequencies.
 2. The limit decreases in line with the logarithm of the frequency in the range of 0.15 to 0.50 MHz.
 3. All emanations from a class A/B digital device or system, including any network of conductors and apparatus connected thereto, shall not exceed the level of field strengths specified above.

4.1.2 TEST INSTRUMENTS

DESCRIPTION & MANUFACTURER	MODEL NO.	SERIAL NO.	CALIBRATED DATE	CALIBRATED UNTIL
ROHDE & SCHWARZ Test Receiver	ESCS 30	100287	Mar. 01, 2010	Feb. 28, 2011
Line-Impedance Stabilization Network (for EUT)	NSLK 8127	8127-523	Sep. 23, 2009	Sep. 22, 2010
Line-Impedance Stabilization Network (for Peripheral)	ENV-216	100072	June 08, 2009	June 07, 2010
RF Cable (JYBAO)	5DFB	COACAB-001	Dec. 14, 2009	Dec. 13, 2010
50 ohms Terminator	50	3	Oct. 28, 2009	Oct. 27, 2010
Software	BV ADT_ Cond_V7.3.7	NA	NA	NA

Note:

1. The calibration interval of the above test instruments is 12 months and the calibrations are traceable to NML/ROC and NIST/USA.
2. The test was performed in Shielded Room No. A.
3. The VCCI Con A Registration No. is C-817.

4.1.3 TEST PROCEDURES

- a. The EUT was placed 0.4 meters from the conducting wall of the shielded room with EUT being connected to the power mains through a line impedance stabilization network (LISN). Other support units were connected to the power mains through another LISN. The two LISNs provide 50 ohm/ 50uH of coupling impedance for the measuring instrument.
- b. Both lines of the power mains connected to the EUT were checked for maximum conducted interference.
- c. The frequency range from 150kHz to 30MHz was searched. Emission levels under (Limit - 20dB) were not recorded.

4.1.4 DEVIATION FROM TEST STANDARD

No deviation

4.1.5 TEST SETUP

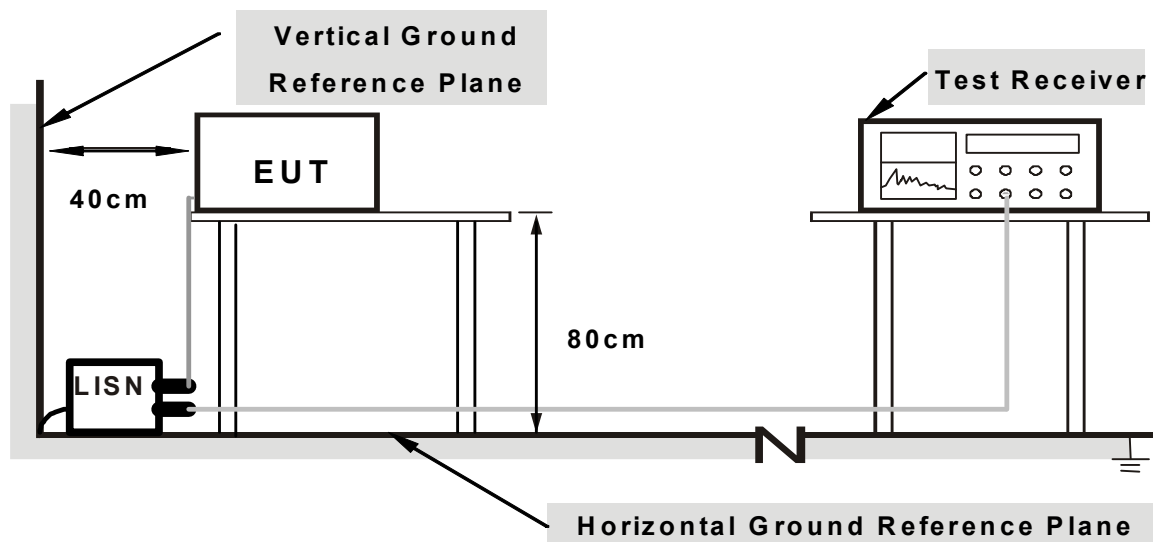

Note: 1. Support units were connected to second LISN.

2. Both of LISNs (AMN) are 80 cm from EUT and at least 80 from other units and other metal planes

For the actual test configuration, please refer to the related item – Photographs of the Test Configuration.

4.1.6 EUT OPERATING CONDITIONS

1. Plug the EUT into the support unit 1 (Notebook computer) which was placed on a testing table.
2. The communication partner run test program “QA RT3X7X V1.5.2.0” to enable EUT under transmission/receiving condition continuously at specific channel frequency.

4.1.7 TEST RESULTS

802.11n (40MHz) OFDM MODULATION

PHASE	Line (L)	6dB BANDWIDTH	9 kHz
--------------	----------	----------------------	-------

No	Freq.	Corr.	Reading Value		Emission Level		Limit		Margin	
	[MHz]	Factor	[dB (uV)]		[dB (uV)]		[dB (uV)]		(dB)	
		(dB)	Q.P.	AV.	Q.P.	AV.	Q.P.	AV.	Q.P.	AV.
1	0.170	0.04	49.31	41.10	49.35	41.14	64.98	54.98	-15.64	-13.85
2	0.226	0.04	44.01	37.32	44.05	37.36	62.59	52.59	-18.54	-15.23
3	0.283	0.04	40.65	34.29	40.69	34.33	60.73	50.73	-20.03	-16.39
4	0.338	0.05	37.58	32.66	37.63	32.71	59.26	49.26	-21.64	-16.56
5	3.742	0.20	44.34	29.10	44.54	29.30	56.00	46.00	-11.46	-16.70
6	4.026	0.19	44.12	26.97	44.31	27.16	56.00	46.00	-11.69	-18.84

- REMARKS:**
1. Q.P. and AV. are abbreviations of quasi-peak and average individually.
 2. "-": The Quasi-peak reading value also meets average limit and measurement with the average detector is unnecessary.
 3. The emission levels of other frequencies were very low against the limit.
 4. Margin value = Emission level - Limit value
 5. Correction factor = Insertion loss + Cable loss
 6. Emission Level = Correction Factor + Reading Value.

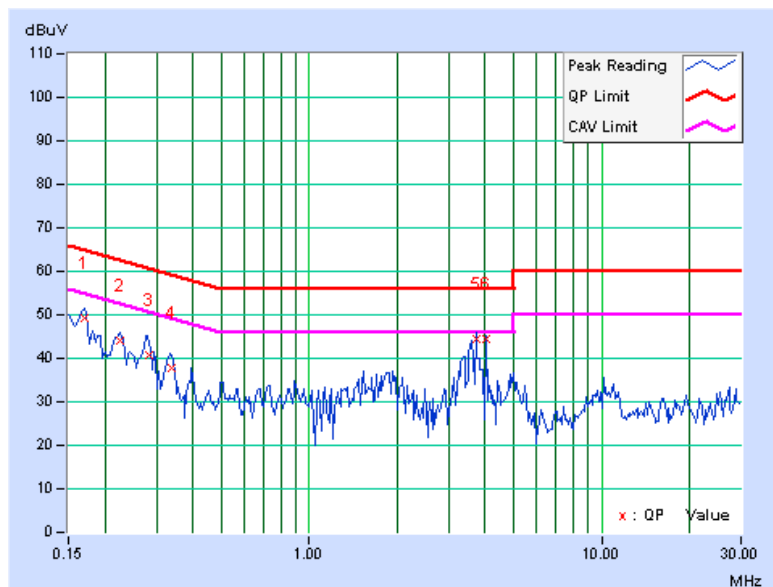

PHASE	Neutral (N)	6dB BANDWIDTH	9 kHz
--------------	-------------	----------------------	-------

No	Freq. [MHz]	Corr. Factor (dB)	Reading Value		Emission Level		Limit		Margin	
			[dB (uV)]		[dB (uV)]		[dB (uV)]		(dB)	
			Q.P.	AV.	Q.P.	AV.	Q.P.	AV.	Q.P.	AV.
1	0.170	0.05	47.98	40.03	48.03	40.08	64.98	54.98	-16.96	-14.91
2	0.224	0.05	43.42	37.72	43.47	37.77	62.66	52.66	-19.19	-14.89
3	0.287	0.05	36.85	30.31	36.90	30.36	60.62	50.62	-23.71	-20.25
4	1.816	0.24	36.26	27.79	36.50	28.03	56.00	46.00	-19.50	-17.97
5	3.457	0.22	40.98	27.70	41.20	27.92	56.00	46.00	-14.80	-18.08
6	4.816	0.26	36.46	22.67	36.72	22.93	56.00	46.00	-19.28	-23.07

- REMARKS:**
1. Q.P. and AV. are abbreviations of quasi-peak and average individually.
 2. "-": The Quasi-peak reading value also meets average limit and measurement with the average detector is unnecessary.
 3. The emission levels of other frequencies were very low against the limit.
 4. Margin value = Emission level - Limit value
 5. Correction factor = Insertion loss + Cable loss
 6. Emission Level = Correction Factor + Reading Value.

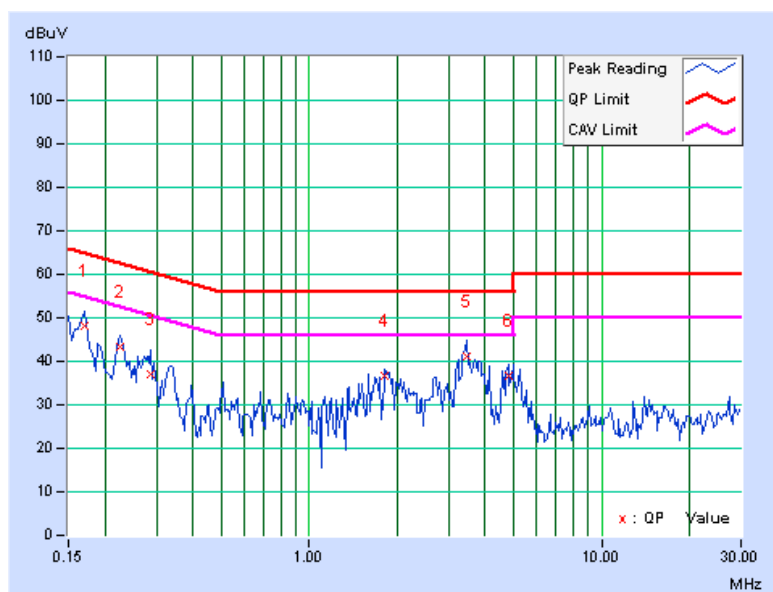

4.2 RADIATED EMISSION MEASUREMENT

4.2.1 LIMITS OF RADIATED EMISSION MEASUREMENT

Emissions radiated outside of the specified bands, shall be according to the general radiated limits in 15.209 as following:

Frequencies (MHz)	Field strength (microvolts/meter)	Measurement distance (meters)
0.009-0.490	2400/F(kHz)	300
0.490-1.705	24000/F(kHz)	30
1.705-30.0	30	30
30-88	100	3
88-216	150	3
216-960	200	3
Above 960	500	3

NOTE:

1. The lower limit shall apply at the transition frequencies.
2. Emission level (dBuV/m) = 20 log Emission level (uV/m).
3. As shown in 15.35(b), for frequencies above 1000MHz, the field strength limits are based on average detector, however, the peak field strength of any emission shall not exceed the maximum permitted average limits, specified above by more than 20dB under any condition of modulation.



A D T

4.2.2 TEST INSTRUMENTS

DESCRIPTION & MANUFACTURER	MODEL NO.	SERIAL NO.	CALIBRATED DATE	CALIBRATED UNTIL
ROHDE & SCHWARZ Spectrum Analyzer	FSP40	100036	Dec. 18, 2009	Dec. 17, 2010
Agilent PSA Spectrum Analyzer	E4446A	MY46180622	May 12, 2010	May 11, 2011
HP Pre_Amplifier	8449B	300801923	Nov. 02, 2009	Nov. 01, 2010
ROHDE & SCHWARZ Test Receiver	ESCS30	847124/029	Aug. 28, 2009	Aug. 27, 2010
SCHWARZBECK TRILOG Broadband Antenna	VULB 9168	138	Apr. 28, 2010	Apr. 27, 2011
Schwarzbeck Horn_Antenna	BBHA9120	D124	Dec. 18, 2009	Dec. 17, 2010
Schwarzbeck Horn_Antenna	BBHA 9170	BBHA9170153	Jan. 22, 2010	Jan. 21, 2011
R&S Loop Antenna	HFH2-Z2	100070	Feb. 3, 2010	Feb. 2, 2012
RF Switches	EMH-011	1001	NA	NA
RF CABLE (Chaintek)	Sucoflex 106	28077	Aug. 14, 2009	Aug. 13, 2010
RF Cable	8DFB	STCCAB-30M-1GHz	NA	NA
Software	ADT_Radiated_V7.6.15.9.2	NA	NA	NA
CT Antenna Tower & Turn Table	NA	NA	NA	NA

- Note: 1. The calibration interval of the above test instruments is 12 months and the calibrations are traceable to NML/ROC and NIST/USA.
2. The horn antenna, preamplifier (model: 8449B) and Spectrum Analyzer (model: FSP40) are used only for the measurement of emission frequency above 1GHz if tested.
3. The test was performed in Open Site No. C.
4. The FCC Site Registration No. is 656396.
5. The VCCI Site Registration No. is R-1626.
6. The CANADA Site Registration No. is IC 7450G-3.

4.2.3 TEST PROCEDURES

- a. The EUT was placed on the top of a rotating table 0.8 meters above the ground at a 10 meters open field site. The table was rotated 360 degrees to determine the position of the highest radiation.
- b. The EUT was set 3 meters away from the interference-receiving antenna, which was mounted on the top of a variable-height antenna tower.
- c. The antenna is a broadband antenna, and its height is varied from one meter to four meters above the ground to determine the maximum value of the field strength. Both horizontal and vertical polarizations of the antenna are set to make the measurement.
- d. For each suspected emission, the EUT was arranged to its worst case and then the antenna was tuned to heights from 1 meter to 4 meters and the rotatable table was turned from 0 degrees to 360 degrees to find the maximum reading.
- e. The test-receiver system was set to quasi-peak detect function and specified bandwidth with maximum hold mode when the test frequency is below 1 GHz.
- f. The test-receiver system was set to peak and average detect function and specified bandwidth with maximum hold mode when the test frequency is above 1 GHz. If the peak reading value also meets average limit, measurement with the average detector is unnecessary.

NOTE:

1. The resolution bandwidth and video bandwidth of test receiver/spectrum analyzer is 120kHz for Quasi-peak detection (QP) at frequency below 1GHz.
2. The resolution bandwidth is 1MHz and video bandwidth of test receiver/spectrum analyzer is 3MHz for Peak detection at frequency above 1GHz. The resolution bandwidth of test receiver/spectrum analyzer is 1 MHz for Average detection (AV) at frequency above 1GHz.
3. For measurement of frequency above 1000 MHz, the EUT was set 3 meters away from the interference-receiving antenna.

4.2.4 DEVIATION FROM TEST STANDARD

No deviation

4.2.5 TEST SETUP

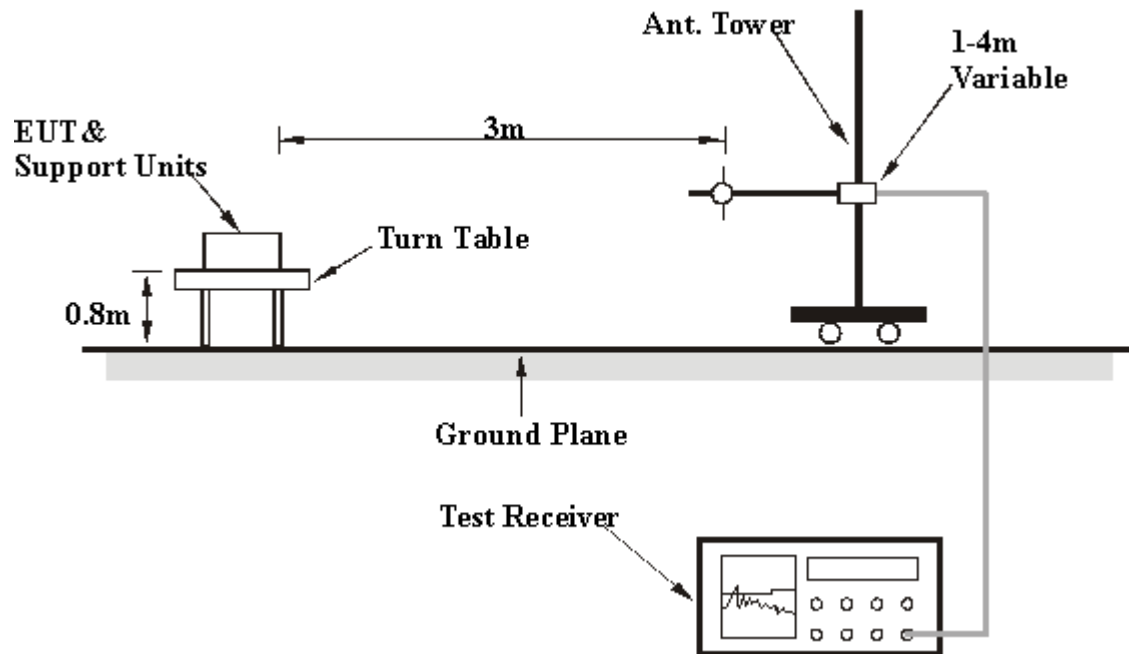

For the actual test configuration, please refer to the related item – Photographs of the Test Configuration.

4.2.6 EUT OPERATING CONDITIONS

Same as 4.1.6



A D T

4.2.7 TEST RESULTS

BELOW 1GHz WORST-CASE DATA : 802.11n (40MHz) OFDM MODULATION

EUT TEST CONDITION		MEASUREMENT DETAIL	
CHANNEL	Channel 7	FREQUENCY RANGE	Below 1000MHz
INPUT POWER (SYSTEM)	120Vac, 60 Hz	DETECTOR FUNCTION	Quasi-Peak
ENVIRONMENTAL CONDITIONS	28deg. C, 60%RH 1011 hPa	TESTED BY	Wen Yu

ANTENNA POLARITY & TEST DISTANCE: HORIZONTAL AT 3 M								
NO.	FREQ. (MHz)	EMISSION LEVEL (dBuV/m)	LIMIT (dBuV/m)	MARGIN (dB)	ANTENNA HEIGHT (m)	TABLE ANGLE (Degree)	RAW VALUE (dBuV)	CORRECTION FACTOR (dB/m)
1	120.00	23.3 QP	43.5	-20.2	1.42 H	357	11.37	11.95
2	213.47	33.2 QP	43.5	-10.3	1.00 H	149	20.83	12.36
3	240.00	30.0 QP	46.0	-16.0	1.00 H	187	16.68	13.33
4	360.00	33.2 QP	46.0	-12.8	1.00 H	19	15.67	17.52
5	480.00	30.2 QP	46.0	-15.9	1.00 H	283	9.41	20.74
6	639.23	28.4 QP	46.0	-17.6	1.19 H	261	4.13	24.26
7	840.04	36.1 QP	46.0	-9.9	1.00 H	287	8.88	27.21
8	960.05	33.5 QP	54.0	-20.5	1.18 H	290	4.81	28.68
ANTENNA POLARITY & TEST DISTANCE: VERTICAL AT 3 M								
NO.	FREQ. (MHz)	EMISSION LEVEL (dBuV/m)	LIMIT (dBuV/m)	MARGIN (dB)	ANTENNA HEIGHT (m)	TABLE ANGLE (Degree)	RAW VALUE (dBuV)	CORRECTION FACTOR (dB/m)
1	60.00	29.7 QP	40.0	-10.3	1.47 V	124	16.43	13.29
2	70.21	32.8 QP	40.0	-7.2	1.00 V	134	20.03	12.81
3	479.99	27.1 QP	46.0	-18.9	1.00 V	263	6.33	20.74
4	600.03	29.8 QP	46.0	-16.2	1.10 V	242	5.97	23.87
5	639.23	31.9 QP	46.0	-14.1	1.36 V	49	7.68	24.26
6	840.04	29.8 QP	46.0	-16.2	1.66 V	10	2.61	27.21
7	960.05	32.8 QP	54.0	-21.2	1.43 V	254	4.12	28.68

- REMARKS:**
1. Emission level (dBuV/m) = Raw Value (dBuV) + Correction Factor (dB/m).
 2. Correction Factor (dB/m) = Antenna Factor (dB/m) + Cable Factor (dB).
 3. The other emission levels were very low against the limit.
 4. Margin value = Emission level – Limit value.



A D T

ABOVE 1GHz WORST-CASE DATA

802.11b DSSS MODULATION

EUT TEST CONDITION		MEASUREMENT DETAIL	
CHANNEL	Channel 1	FREQUENCY RANGE	1 ~ 25GHz
INPUT POWER (SYSTEM)	120Vac, 60 Hz	DETECTOR FUNCTION	Peak (PK) Average (AV)
ENVIRONMENTAL CONDITIONS	26deg. C, 67%RH 1011 hPa	TESTED BY	Wen Yu

ANTENNA POLARITY & TEST DISTANCE: HORIZONTAL AT 3 M								
NO.	FREQ. (MHz)	EMISSION LEVEL (dBuV/m)	LIMIT (dBuV/m)	MARGIN (dB)	ANTENNA HEIGHT (m)	TABLE ANGLE (Degree)	RAW VALUE (dBuV)	CORRECTION FACTOR (dB/m)
1	2390.00	53.7 PK	74.0	-20.3	1.36 H	281	23.6	30.10
2	2390.00	41.5 AV	54.0	-12.5	1.36 H	281	11.40	30.10
3	*2412.00	94.1 PK			1.35 H	258	64.00	30.10
4	*2412.00	91.8 AV			1.35 H	258	61.70	30.10
5	4824.00	50.0 PK	74.0	-24.0	1.50 H	264	14.60	35.40
6	4824.00	46.5 AV	54.0	-7.5	1.50 H	264	11.10	35.40
ANTENNA POLARITY & TEST DISTANCE: VERTICAL AT 3 M								
NO.	FREQ. (MHz)	EMISSION LEVEL (dBuV/m)	LIMIT (dBuV/m)	MARGIN (dB)	ANTENNA HEIGHT (m)	TABLE ANGLE (Degree)	RAW VALUE (dBuV)	CORRECTION FACTOR (dB/m)
1	2389.90	53.3 PK	74.0	-20.7	1.37 V	264	23.20	30.10
2	2389.90	41.5 AV	54.0	-12.5	1.37 V	264	11.40	30.10
3	*2412.00	98.8 PK			1.09 V	185	68.70	30.10
4	*2412.00	96.7 AV			1.09 V	185	66.60	30.10
5	4824.00	50.6 PK	74.0	-23.4	1.32 V	250	15.20	35.40
6	4824.00	47.9 AV	54.0	-6.1	1.32 V	250	12.50	35.40

- REMARKS:**
1. Emission level (dBuV/m) = Raw Value (dBuV) + Correction Factor (dB/m).
 2. Correction Factor (dB/m) = Antenna Factor (dB/m) + Cable Factor (dB).
 3. The other emission levels were very low against the limit.
 4. Margin value = Emission level – Limit value.
 5. “ * “: Fundamental frequency.



A D T

EUT TEST CONDITION		MEASUREMENT DETAIL	
CHANNEL	Channel 6	FREQUENCY RANGE	1 ~ 25GHz
INPUT POWER (SYSTEM)	120Vac, 60 Hz	DETECTOR FUNCTION	Peak (PK) Average (AV)
ENVIRONMENTAL CONDITIONS	26deg. C, 67%RH 1011 hPa	TESTED BY	Wen Yu

ANTENNA POLARITY & TEST DISTANCE: HORIZONTAL AT 3 M								
NO.	FREQ. (MHz)	EMISSION LEVEL (dBuV/m)	LIMIT (dBuV/m)	MARGIN (dB)	ANTENNA HEIGHT (m)	TABLE ANGLE (Degree)	RAW VALUE (dBuV)	CORRECTION FACTOR (dB/m)
1	*2437.00	94.1 PK			1.36 H	258	63.90	30.20
2	*2437.00	91.4 AV			1.36 H	258	61.20	30.20
3	4874.00	51.4 PK	74.0	-22.6	1.44 H	276	15.90	35.50
4	4874.00	49.2 AV	54.0	-4.8	1.44 H	276	13.70	35.50
5	7311.00	48.3 PK	74.0	-25.7	1.50 H	266	6.30	42.00
6	7311.00	36.8 AV	54.0	-17.2	1.50 H	266	-5.20	42.00
ANTENNA POLARITY & TEST DISTANCE: VERTICAL AT 3 M								
NO.	FREQ. (MHz)	EMISSION LEVEL (dBuV/m)	LIMIT (dBuV/m)	MARGIN (dB)	ANTENNA HEIGHT (m)	TABLE ANGLE (Degree)	RAW VALUE (dBuV)	CORRECTION FACTOR (dB/m)
1	*2437.00	98.2 PK			1.11 V	185	68.00	30.20
2	*2437.00	95.9 AV			1.11 V	185	65.70	30.20
3	4874.00	53.0 PK	74.0	-21.0	1.33 V	249	17.50	35.50
4	4874.00	51.1 AV	54.0	-2.9	1.33 V	249	15.60	35.50
5	7311.00	49.7 PK	74.0	-24.3	1.45 V	268	7.70	42.00
6	7311.00	36.9 AV	54.0	-17.1	1.45 V	268	-5.10	42.00

- REMARKS:**
1. Emission level (dBuV/m) = Raw Value (dBuV) + Correction Factor (dB/m).
 2. Correction Factor (dB/m) = Antenna Factor (dB/m) + Cable Factor (dB).
 3. The other emission levels were very low against the limit.
 4. Margin value = Emission level – Limit value.
 5. “ * “: Fundamental frequency.



A D T

EUT TEST CONDITION		MEASUREMENT DETAIL	
CHANNEL	Channel 11	FREQUENCY RANGE	1 ~ 25GHz
INPUT POWER (SYSTEM)	120Vac, 60 Hz	DETECTOR FUNCTION	Peak (PK) Average (AV)
ENVIRONMENTAL CONDITIONS	26deg. C, 67%RH 1011 hPa	TESTED BY	Wen Yu

ANTENNA POLARITY & TEST DISTANCE: HORIZONTAL AT 3 M								
NO.	FREQ. (MHz)	EMISSION LEVEL (dBuV/m)	LIMIT (dBuV/m)	MARGIN (dB)	ANTENNA HEIGHT (m)	TABLE ANGLE (Degree)	RAW VALUE (dBuV)	CORRECTION FACTOR (dB/m)
1	*2462.00	93.9 PK			1.35 H	257	63.60	30.30
2	*2462.00	90.8 AV			1.35 H	257	60.50	30.30
3	2483.50	53.7 PK	74.0	-20.3	1.35 H	256	23.30	30.40
4	2483.50	41.4 AV	54.0	-12.6	1.35 H	256	11.00	30.40
5	4924.00	52.9 PK	74.0	-21.1	1.52 H	261	17.30	35.60
6	4924.00	50.7 AV	54.0	-3.3	1.52 H	261	15.10	35.60
7	7386.00	48.4 PK	74.0	-25.6	1.52 H	263	6.30	42.10
8	7386.00	36.9 AV	54.0	-17.1	1.52 H	263	-5.20	42.10
ANTENNA POLARITY & TEST DISTANCE: VERTICAL AT 3 M								
NO.	FREQ. (MHz)	EMISSION LEVEL (dBuV/m)	LIMIT (dBuV/m)	MARGIN (dB)	ANTENNA HEIGHT (m)	TABLE ANGLE (Degree)	RAW VALUE (dBuV)	CORRECTION FACTOR (dB/m)
1	*2462.00	97.9 PK			1.10 V	188	67.60	30.30
2	*2462.00	95.3 AV			1.10 V	188	65.00	30.30
3	2483.50	53.0 PK	74.0	-21.0	1.40 V	207	22.60	30.40
4	2483.50	41.5 AV	54.0	-12.5	1.40 V	207	11.10	30.40
5	4924.00	53.9 PK	74.0	-20.1	1.37 V	245	18.30	35.60
6	4924.00	52.7 AV	54.0	-1.3	1.37 V	245	17.10	35.60
7	7386.00	49.6 PK	74.0	-24.4	1.46 V	270	7.50	42.10
8	7386.00	36.7 AV	54.0	-17.3	1.46 V	270	-5.40	42.10

- REMARKS:**
1. Emission level (dBuV/m) = Raw Value (dBuV) + Correction Factor (dB/m).
 2. Correction Factor (dB/m) = Antenna Factor (dB/m) + Cable Factor (dB).
 3. The other emission levels were very low against the limit.
 4. Margin value = Emission level – Limit value.
 5. “ * “: Fundamental frequency.



A D T

RESTRICTED BANDEDGE (802.11b MODE, CH1, HORIZONTAL)

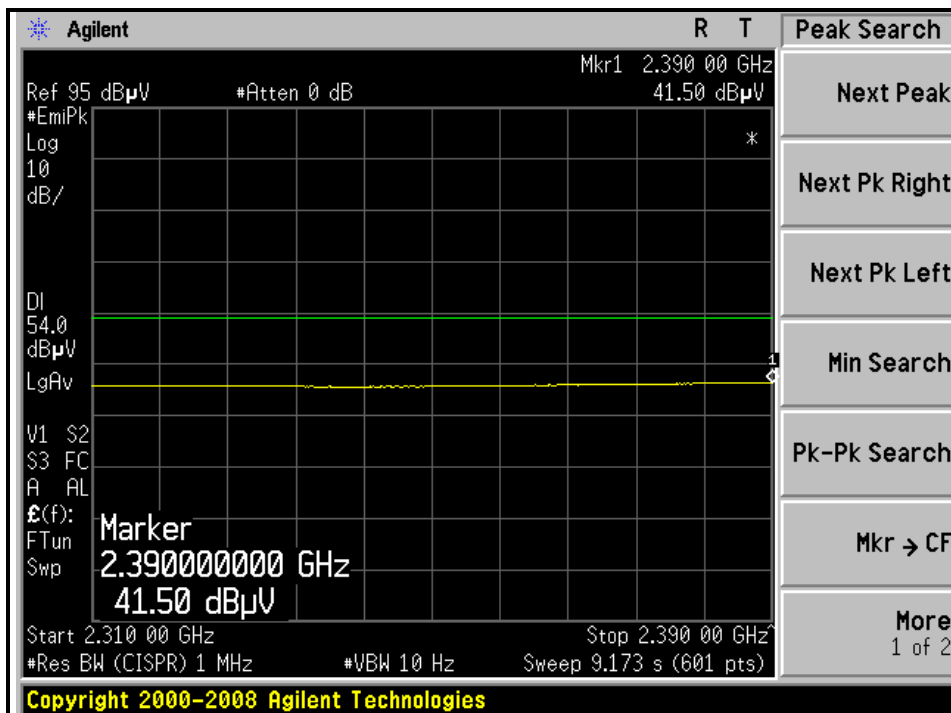
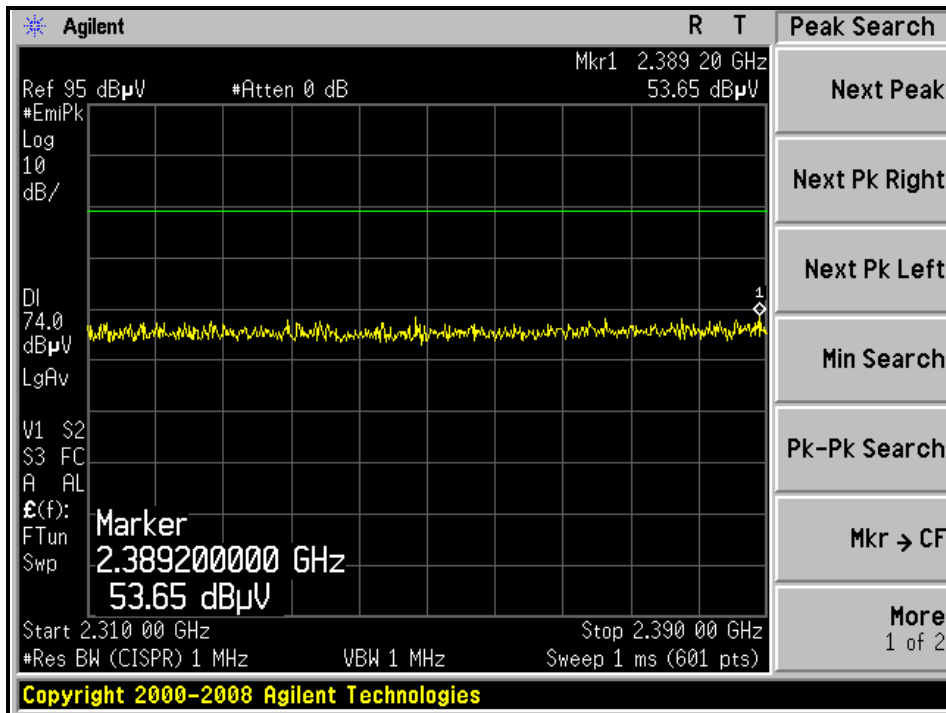



A D T

RESTRICTED BANDEDGE (802.11b MODE, CH1, VERTICAL)

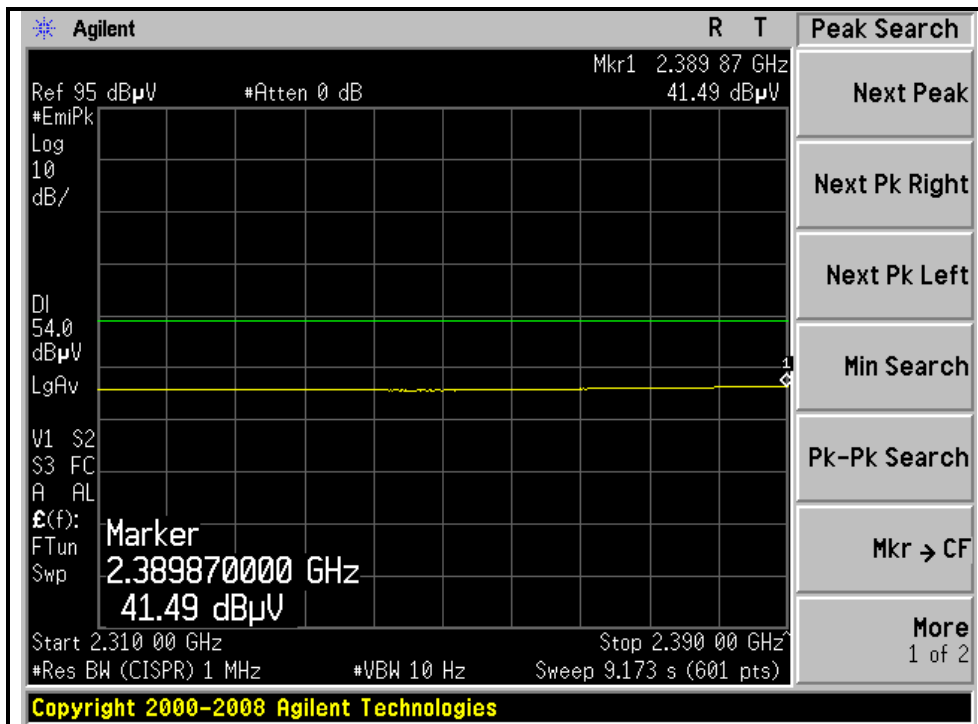
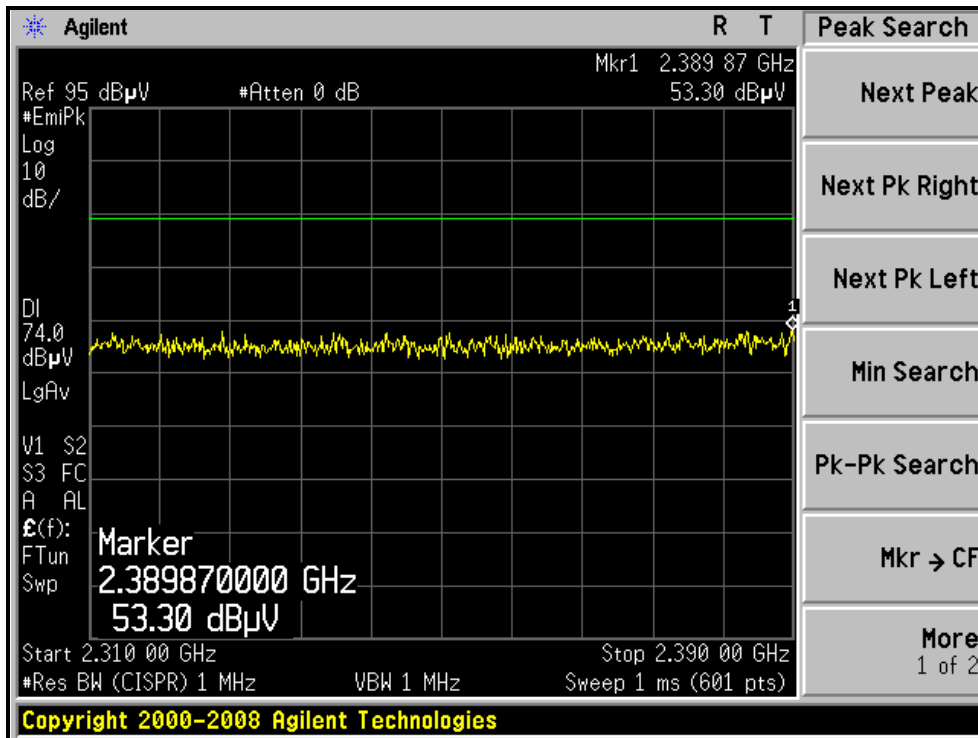



A D T

RESTRICTED BANDEDGE (802.11b MODE,CH11, HORIZONTAL)

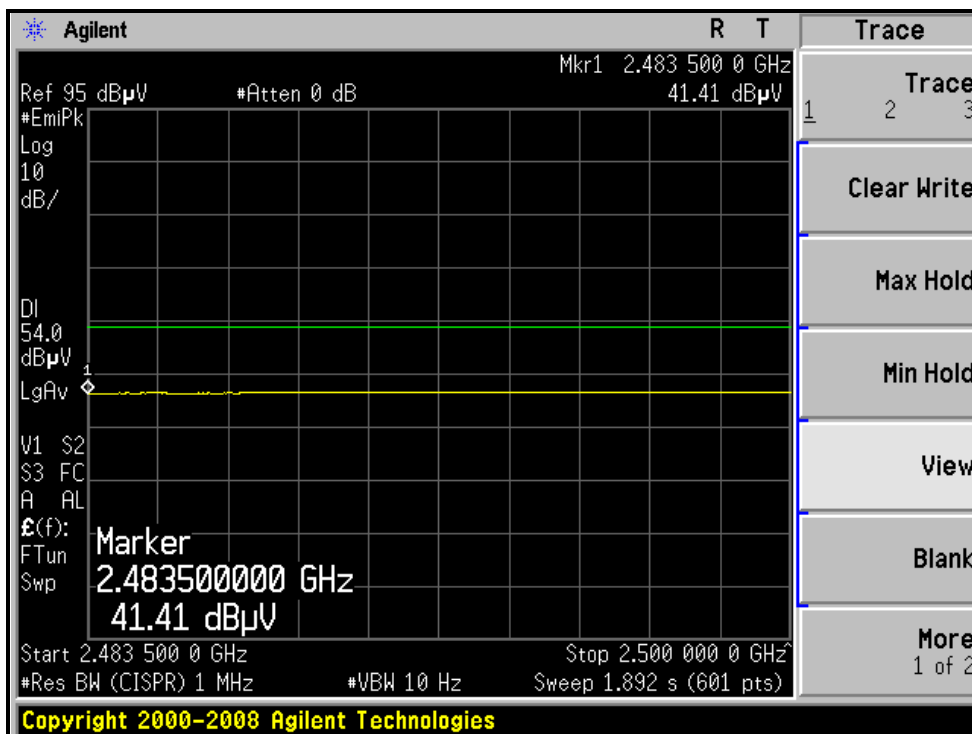
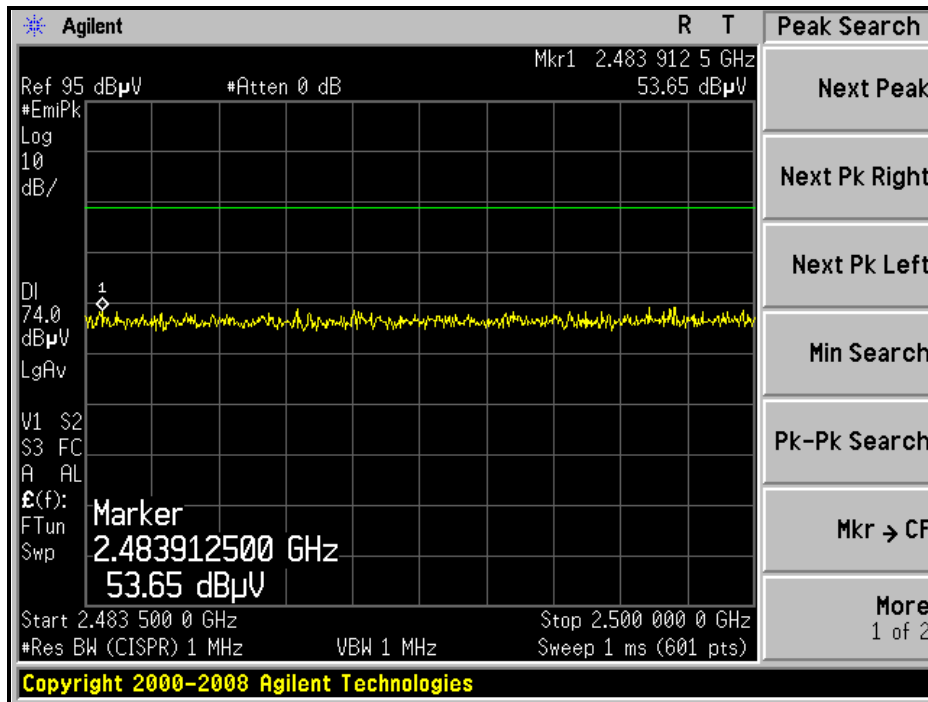



A D T

RESTRICTED BANDEDGE (802.11b MODE, CH11, VERTICAL)

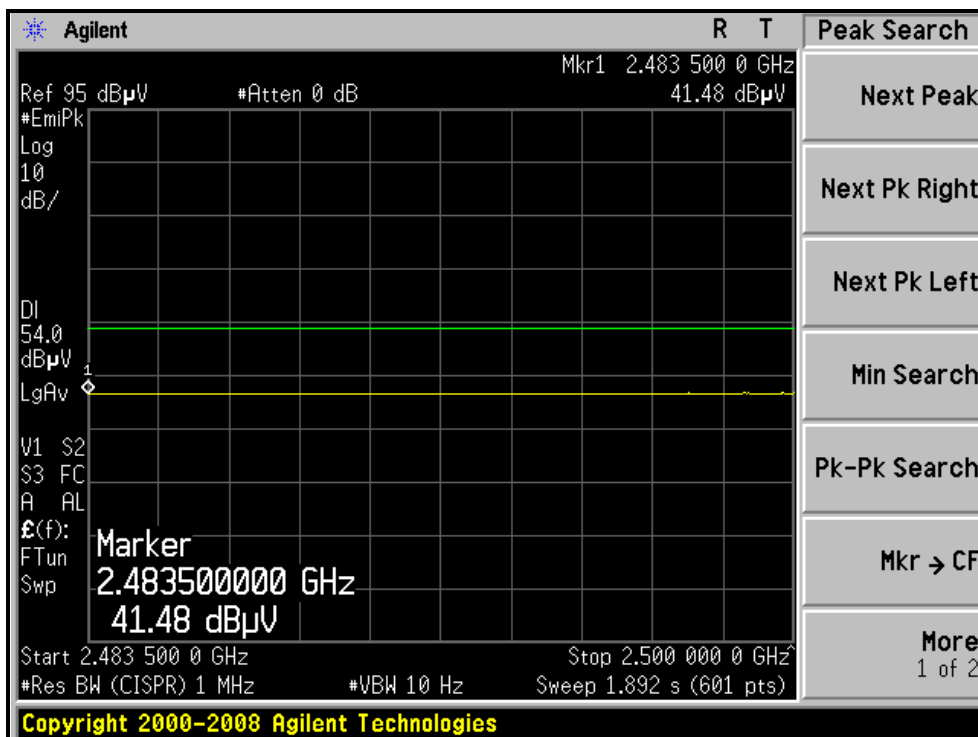
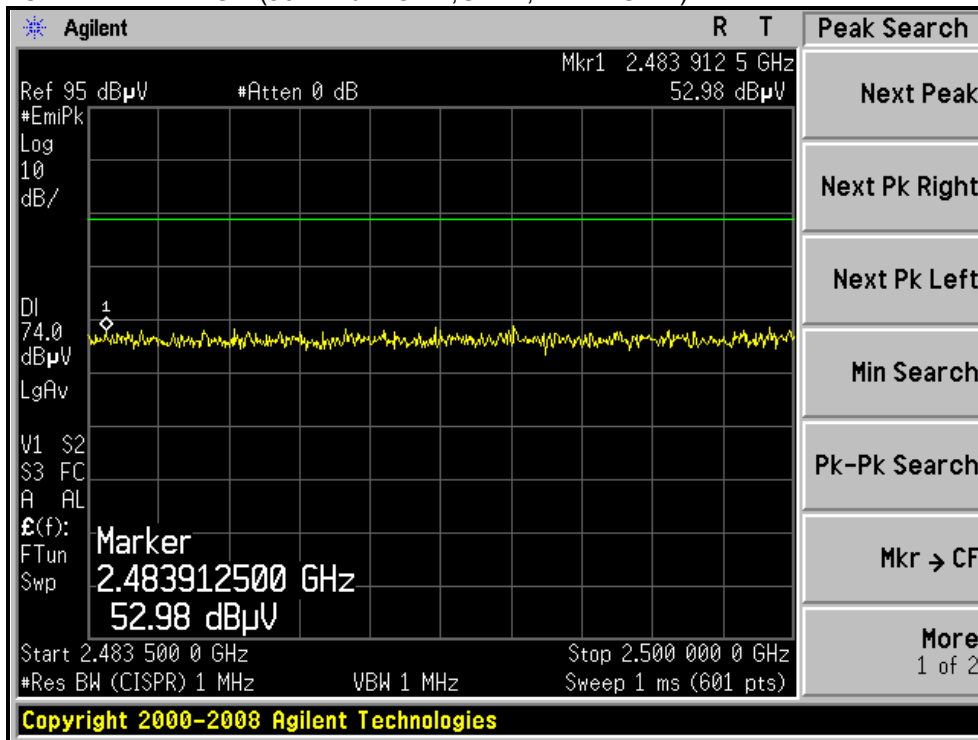



A D T

802.11g OFDM MODULATION

EUT TEST CONDITION		MEASUREMENT DETAIL	
CHANNEL	Channel 1	FREQUENCY RANGE	1 ~ 25GHz
INPUT POWER (SYSTEM)	120Vac, 60 Hz	DETECTOR FUNCTION	Peak (PK) Average (AV)
ENVIRONMENTAL CONDITIONS	26deg. C, 67%RH 1011 hPa	TESTED BY	Wen Yu

ANTENNA POLARITY & TEST DISTANCE: HORIZONTAL AT 3 M								
NO.	FREQ. (MHz)	EMISSION LEVEL (dBuV/m)	LIMIT (dBuV/m)	MARGIN (dB)	ANTENNA HEIGHT (m)	TABLE ANGLE (Degree)	RAW VALUE (dBuV)	CORRECTION FACTOR (dB/m)
1	2359.90	53.3 PK	74.0	-20.7	1.44 H	98	23.40	29.90
2	2359.90	42.3 AV	54.0	-11.7	1.44 H	98	12.40	29.90
3	*2412.00	97.0 PK			1.35 H	284	66.90	30.10
4	*2412.00	87.4 AV			1.35 H	284	57.30	30.10
5	4824.00	52.7 PK	74.0	-21.3	1.60 H	275	17.30	35.40
6	4824.00	41.1 AV	54.0	-12.9	1.60 H	275	5.70	35.40
ANTENNA POLARITY & TEST DISTANCE: VERTICAL AT 3 M								
NO.	FREQ. (MHz)	EMISSION LEVEL (dBuV/m)	LIMIT (dBuV/m)	MARGIN (dB)	ANTENNA HEIGHT (m)	TABLE ANGLE (Degree)	RAW VALUE (dBuV)	CORRECTION FACTOR (dB/m)
1	2390.00	60.7 PK	74.0	-13.3	1.15 V	186	30.60	30.10
2	2390.00	46.2 AV	54.0	-7.8	1.15 V	186	16.10	30.10
3	*2412.00	103.7 PK			1.10 V	186	73.60	30.10
4	*2412.00	95.0 AV			1.10 V	186	64.90	30.10
5	4824.00	47.2 PK	74.0	-26.8	1.34 V	245	11.80	35.40
6	4824.00	36.4 AV	54.0	-17.6	1.34 V	245	1.00	35.40

- REMARKS:**
1. Emission level (dBuV/m) = Raw Value (dBuV) + Correction Factor (dB/m).
 2. Correction Factor (dB/m) = Antenna Factor (dB/m) + Cable Factor (dB).
 3. The other emission levels were very low against the limit.
 4. Margin value = Emission level – Limit value.
 5. “ * “: Fundamental frequency.



A D T

EUT TEST CONDITION		MEASUREMENT DETAIL	
CHANNEL	Channel 6	FREQUENCY RANGE	1 ~ 25GHz
INPUT POWER (SYSTEM)	120Vac, 60 Hz	DETECTOR FUNCTION	Peak (PK) Average (AV)
ENVIRONMENTAL CONDITIONS	26deg. C, 67%RH 1011 hPa	TESTED BY	Wen Yu

ANTENNA POLARITY & TEST DISTANCE: HORIZONTAL AT 3 M								
NO.	FREQ. (MHz)	EMISSION LEVEL (dBuV/m)	LIMIT (dBuV/m)	MARGIN (dB)	ANTENNA HEIGHT (m)	TABLE ANGLE (Degree)	RAW VALUE (dBuV)	CORRECTION FACTOR (dB/m)
1	*2437.00	96.6 PK			1.35 H	260	66.40	30.20
2	*2437.00	86.8 AV			1.35 H	260	56.60	30.20
3	4874.00	50.2 PK	74.0	-23.8	1.60 H	275	14.70	35.50
4	4874.00	37.6 AV	54.0	-16.4	1.60 H	275	2.10	35.50
5	7311.00	48.4 PK	74.0	-25.6	1.51 H	259	6.40	42.00
6	7311.00	36.5 AV	54.0	-17.5	1.51 H	259	-5.50	42.00

ANTENNA POLARITY & TEST DISTANCE: VERTICAL AT 3 M								
NO.	FREQ. (MHz)	EMISSION LEVEL (dBuV/m)	LIMIT (dBuV/m)	MARGIN (dB)	ANTENNA HEIGHT (m)	TABLE ANGLE (Degree)	RAW VALUE (dBuV)	CORRECTION FACTOR (dB/m)
1	*2437.00	100.8 PK			1.10 V	185	70.60	30.20
2	*2437.00	91.5 AV			1.10 V	185	61.30	30.20
3	4874.00	52.3 PK	74.0	-21.7	1.35 V	245	16.80	35.50
4	4874.00	38.5 AV	54.0	-15.5	1.35 V	245	3.00	35.50
5	7311.00	49.6 PK	74.0	-24.4	1.44 V	259	7.60	42.00
6	7311.00	36.8 AV	54.0	-17.2	1.44 V	259	-5.20	42.00

- REMARKS:**
1. Emission level (dBuV/m) = Raw Value (dBuV) + Correction Factor (dB/m).
 2. Correction Factor (dB/m) = Antenna Factor (dB/m) + Cable Factor (dB).
 3. The other emission levels were very low against the limit.
 4. Margin value = Emission level – Limit value.
 5. “ * “: Fundamental frequency.



A D T

EUT TEST CONDITION		MEASUREMENT DETAIL	
CHANNEL	Channel 11	FREQUENCY RANGE	1 ~ 25GHz
INPUT POWER (SYSTEM)	120Vac, 60 Hz	DETECTOR FUNCTION	Peak (PK) Average (AV)
ENVIRONMENTAL CONDITIONS	26deg. C, 67%RH 1011 hPa	TESTED BY	Wen Yu

ANTENNA POLARITY & TEST DISTANCE: HORIZONTAL AT 3 M

NO.	FREQ. (MHz)	EMISSION LEVEL (dBuV/m)	LIMIT (dBuV/m)	MARGIN (dB)	ANTENNA HEIGHT (m)	TABLE ANGLE (Degree)	RAW VALUE (dBuV)	CORRECTION FACTOR (dB/m)
1	*2462.00	96.3 PK			1.35 H	257	66.00	30.30
2	*2462.00	86.5 AV			1.35 H	257	56.20	30.30
3	2483.50	55.0 PK	74.0	-19.0	1.36 H	99	24.6	30.40
4	2483.50	41.5 AV	54.0	-12.5	1.36 H	99	11.1	30.40
5	4924.00	51.7 PK	74.0	-22.3	1.60 H	277	16.10	35.60
6	4924.00	39.8 AV	54.0	-14.2	1.60 H	277	4.20	35.60
7	7386.00	48.3 PK	74.0	-25.7	1.53 H	264	6.20	42.10
8	7386.00	36.7 AV	54.0	-17.3	1.53 H	264	-5.40	42.10

ANTENNA POLARITY & TEST DISTANCE: VERTICAL AT 3 M

NO.	FREQ. (MHz)	EMISSION LEVEL (dBuV/m)	LIMIT (dBuV/m)	MARGIN (dB)	ANTENNA HEIGHT (m)	TABLE ANGLE (Degree)	RAW VALUE (dBuV)	CORRECTION FACTOR (dB/m)
1	*2462.00	102.1 PK			1.40 V	188	71.80	30.30
2	*2462.00	93.1 AV			1.40 V	188	62.80	30.30
3	2483.50	62.8 PK	74.0	-11.2	1.38 V	189	32.40	30.40
4	2483.50	46.0 AV	54.0	-8.0	1.38 V	189	15.60	30.40
5	4924.00	53.9 PK	74.0	-20.1	1.30 V	243	18.30	35.60
6	4924.00	41.2 AV	54.0	-12.8	1.30 V	243	5.60	35.60
7	7386.00	49.5 PK	74.0	-24.5	1.45 V	269	7.40	42.10
8	7386.00	36.5 AV	54.0	-17.5	1.45 V	269	-5.60	42.10

- REMARKS:**
1. Emission level (dBuV/m) = Raw Value (dBuV) + Correction Factor (dB/m).
 2. Correction Factor (dB/m) = Antenna Factor (dB/m) + Cable Factor (dB).
 3. The other emission levels were very low against the limit.
 4. Margin value = Emission level – Limit value.
 5. “ * “: Fundamental frequency.



A D T

RESTRICTED BANDEDGE (802.11g MODE, CH1, HORIZONTAL)

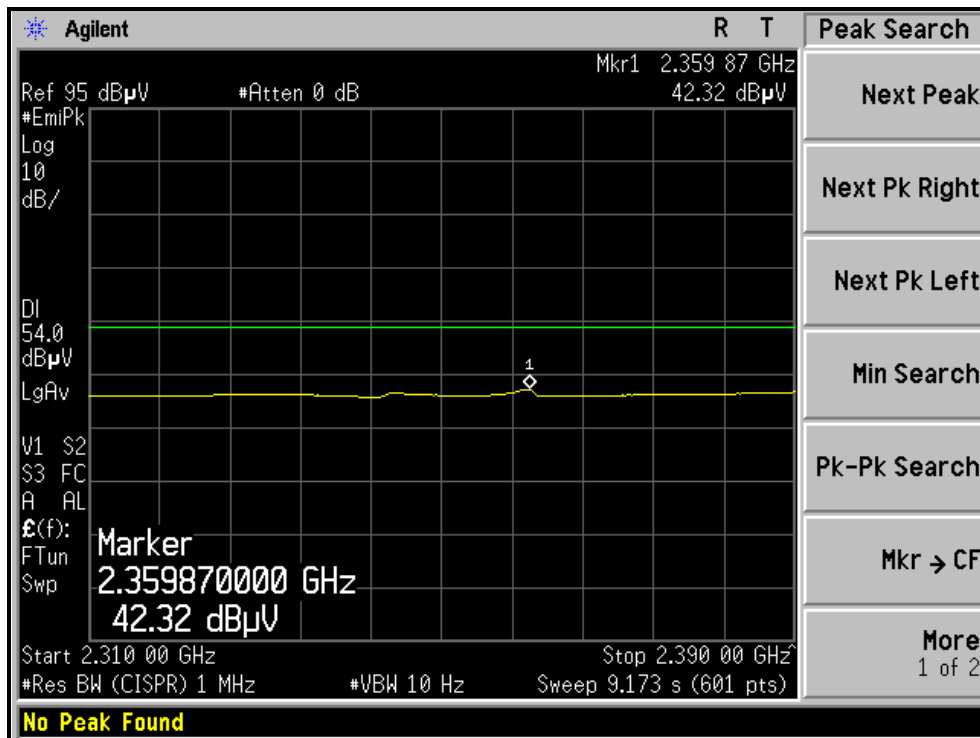
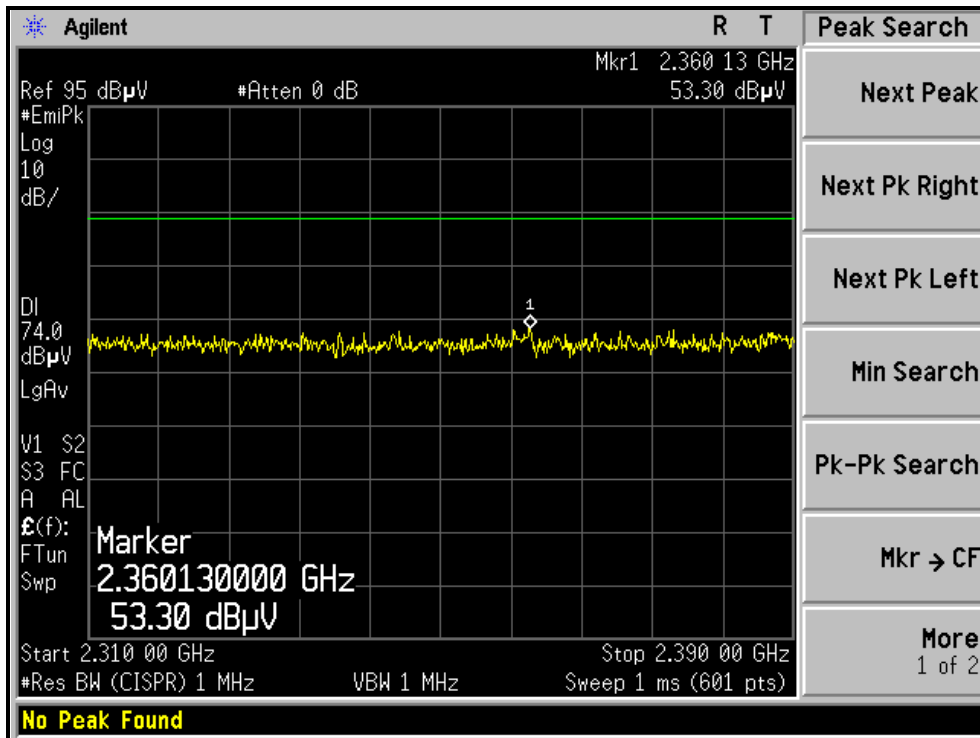



A D T

RESTRICTED BANDEDGE (802.11g MODE, CH1, VERTICAL)

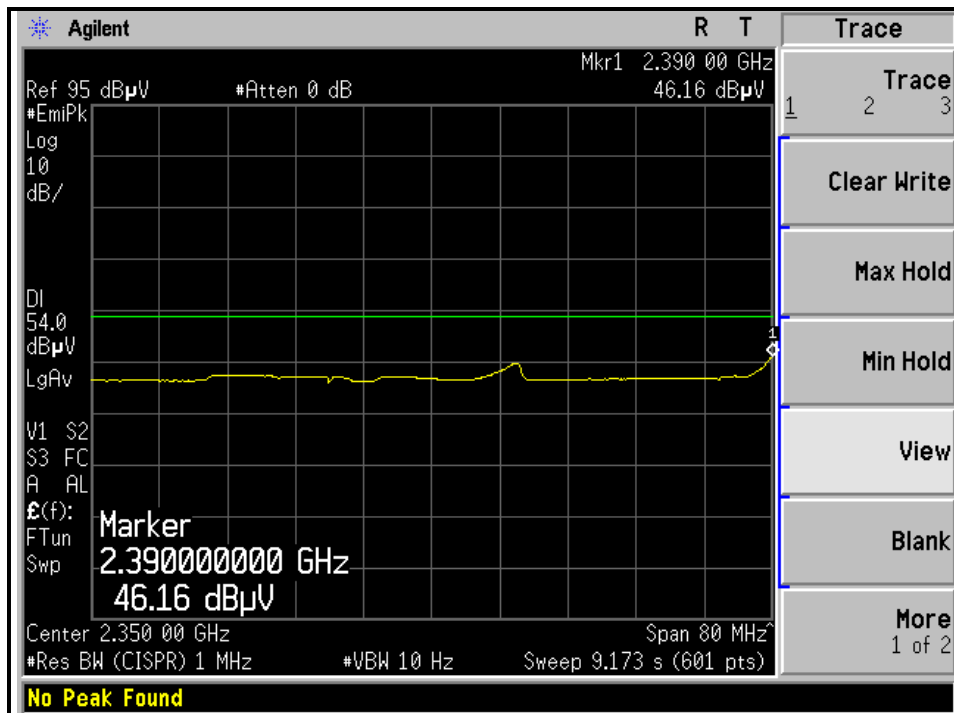
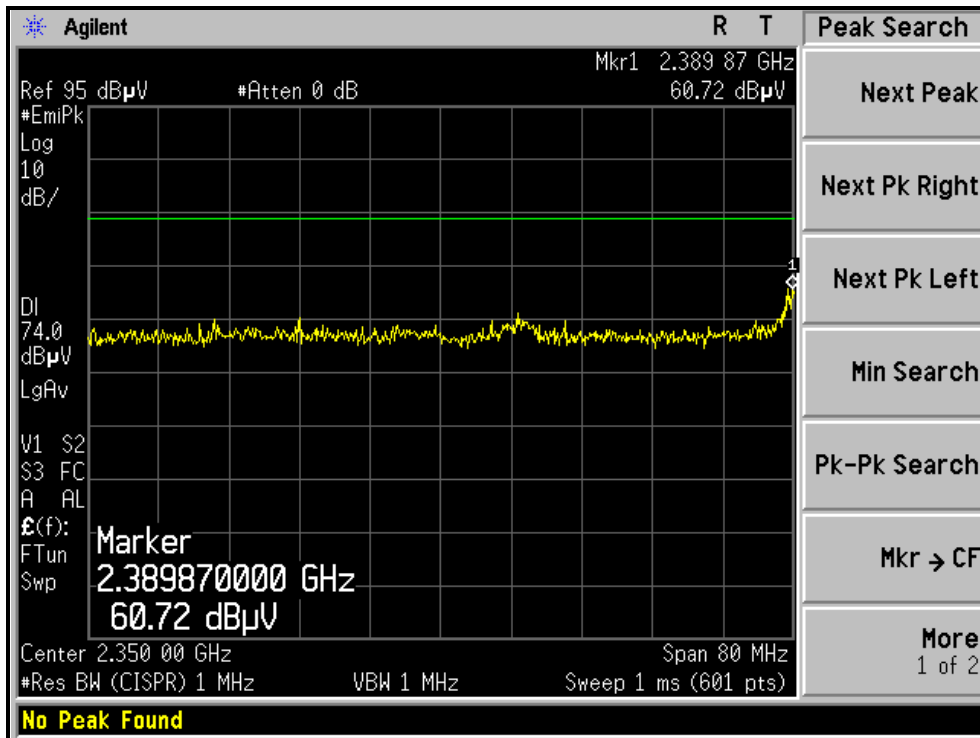



A D T

RESTRICTED BANDEDGE (802.11g MODE, CH11, HORIZONTAL)

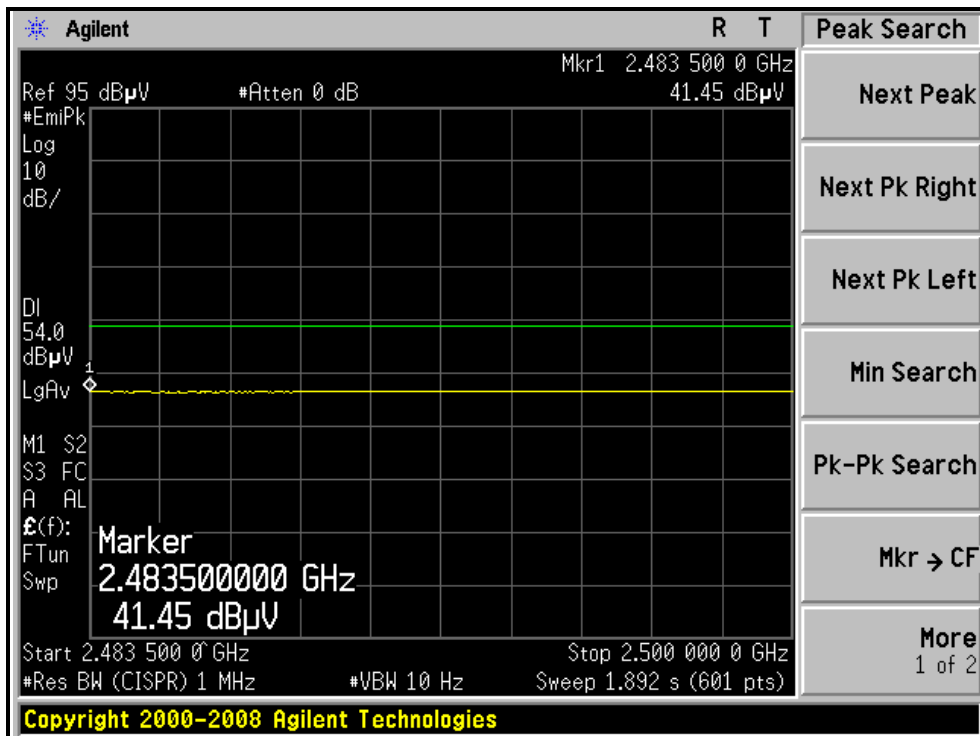
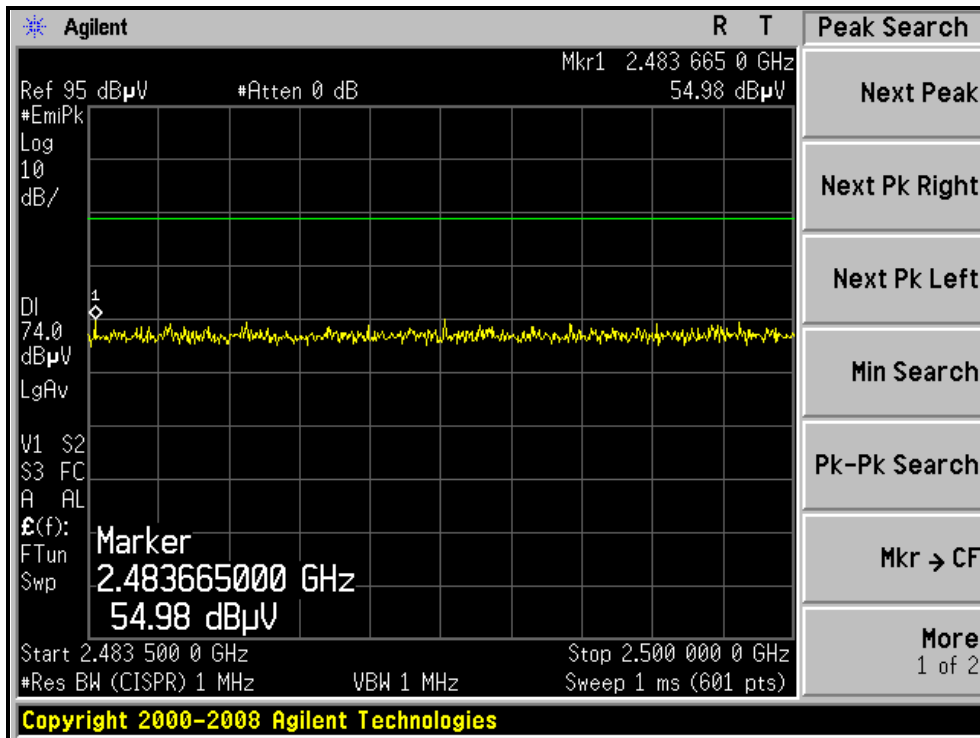



A D T

RESTRICTED BANDEDGE (802.11g MODE, CH11, VERTICAL)

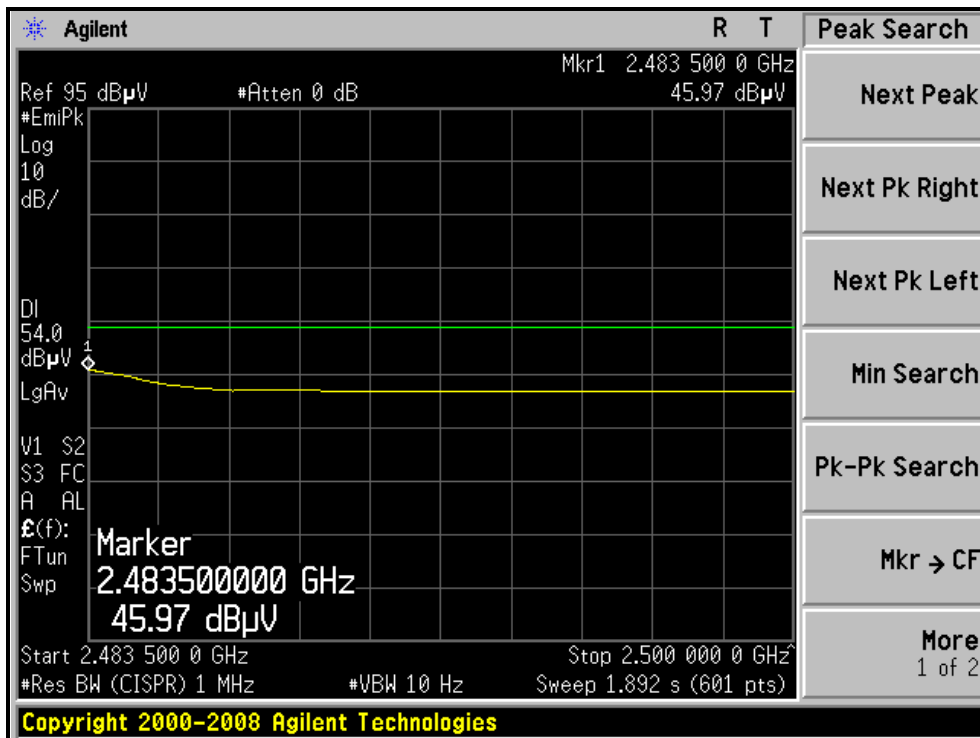
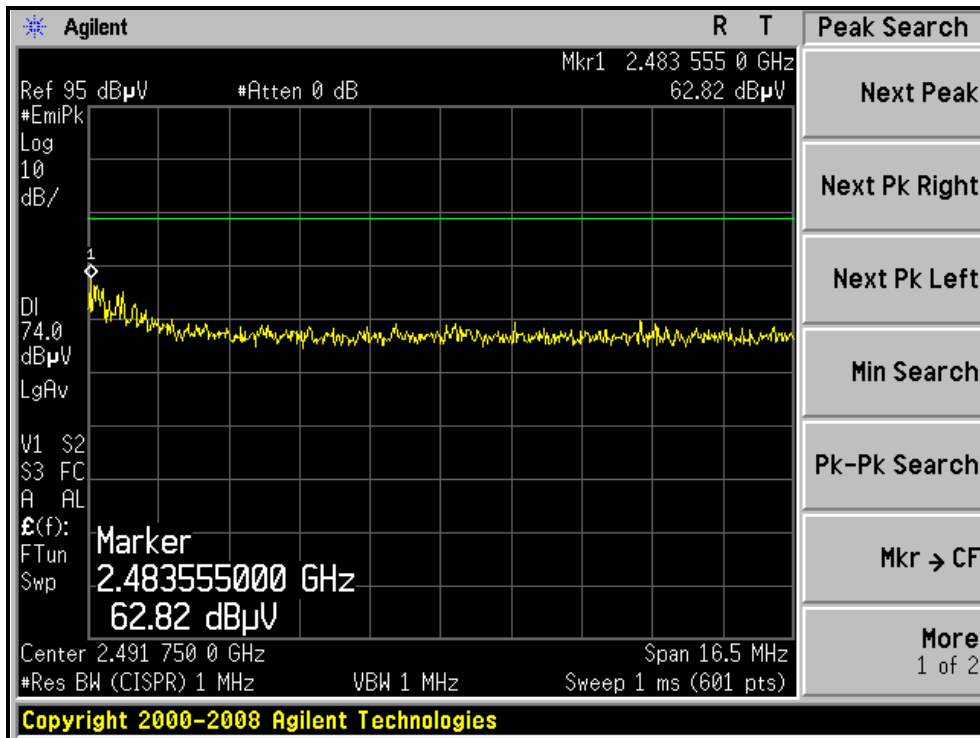



A D T

802.11n (20MHz) OFDM MODULATION

EUT TEST CONDITION		MEASUREMENT DETAIL	
CHANNEL	Channel 1	FREQUENCY RANGE	1 ~ 25GHz
INPUT POWER (SYSTEM)	120Vac, 60 Hz	DETECTOR FUNCTION	Peak (PK) Average (AV)
ENVIRONMENTAL CONDITIONS	26deg. C, 67%RH 1011 hPa	TESTED BY	Wen Yu

ANTENNA POLARITY & TEST DISTANCE: HORIZONTAL AT 3 M								
NO.	FREQ. (MHz)	EMISSION LEVEL (dBuV/m)	LIMIT (dBuV/m)	MARGIN (dB)	ANTENNA HEIGHT (m)	TABLE ANGLE (Degree)	RAW VALUE (dBuV)	CORRECTION FACTOR (dB/m)
1	2390.00	56.8 PK	74.0	-17.2	1.32 H	267	26.70	30.10
2	2390.00	43.1 AV	54.0	-10.9	1.32 H	267	13.00	30.10
3	*2412.00	96.2 PK			1.34 H	284	66.10	30.10
4	*2412.00	87.2 AV			1.34 H	284	57.10	30.10
5	4824.00	50.5 PK	74.0	-23.5	1.50 H	279	15.10	35.40
6	4824.00	36.9 AV	54.0	-17.1	1.50 H	279	1.50	35.40
ANTENNA POLARITY & TEST DISTANCE: VERTICAL AT 3 M								
NO.	FREQ. (MHz)	EMISSION LEVEL (dBuV/m)	LIMIT (dBuV/m)	MARGIN (dB)	ANTENNA HEIGHT (m)	TABLE ANGLE (Degree)	RAW VALUE (dBuV)	CORRECTION FACTOR (dB/m)
1	2390.00	58.5 PK	74.0	-15.5	1.11 V	184	28.40	30.10
2	2390.00	43.9 AV	54.0	-10.1	1.11 V	184	13.80	30.10
3	*2412.00	99.6 PK			1.12 V	183	69.50	30.10
4	*2412.00	90.1 AV			1.12 V	183	60.00	30.10
5	4824.00	50.6 PK	74.0	-23.4	1.34 V	257	15.20	35.40
6	4824.00	37.5 AV	54.0	-16.5	1.34 V	257	2.10	35.40

- REMARKS:**
1. Emission level (dBuV/m) = Raw Value (dBuV) + Correction Factor (dB/m).
 2. Correction Factor (dB/m) = Antenna Factor (dB/m) + Cable Factor (dB).
 3. The other emission levels were very low against the limit.
 4. Margin value = Emission level – Limit value.
 5. “ * “: Fundamental frequency.



A D T

EUT TEST CONDITION		MEASUREMENT DETAIL	
CHANNEL	Channel 6	FREQUENCY RANGE	1 ~ 25GHz
INPUT POWER (SYSTEM)	120Vac, 60 Hz	DETECTOR FUNCTION	Peak (PK) Average (AV)
ENVIRONMENTAL CONDITIONS	26deg. C, 67%RH 1011 hPa	TESTED BY	Wen Yu

ANTENNA POLARITY & TEST DISTANCE: HORIZONTAL AT 3 M								
NO.	FREQ. (MHz)	EMISSION LEVEL (dBuV/m)	LIMIT (dBuV/m)	MARGIN (dB)	ANTENNA HEIGHT (m)	TABLE ANGLE (Degree)	RAW VALUE (dBuV)	CORRECTION FACTOR (dB/m)
1	*2437.00	95.8 PK			1.36 H	259	65.60	30.20
2	*2437.00	86.9 AV			1.36 H	259	56.70	30.20
3	4874.00	50.2 PK	74.0	-23.8	1.59 H	277	14.70	35.50
4	4874.00	36.6 AV	54.0	-17.4	1.59 H	277	1.10	35.50
5	7311.00	48.2 PK	74.0	-25.8	1.51 H	263	6.20	42.00
6	7311.00	36.5 AV	54.0	-17.5	1.51 H	263	-5.50	42.00
ANTENNA POLARITY & TEST DISTANCE: VERTICAL AT 3 M								
NO.	FREQ. (MHz)	EMISSION LEVEL (dBuV/m)	LIMIT (dBuV/m)	MARGIN (dB)	ANTENNA HEIGHT (m)	TABLE ANGLE (Degree)	RAW VALUE (dBuV)	CORRECTION FACTOR (dB/m)
1	*2437.00	98.6 PK			1.11 V	184	68.40	30.20
2	*2437.00	89.0 AV			1.11 V	184	58.80	30.20
3	4874.00	51.2 PK	74.0	-22.8	1.35 V	249	15.70	35.50
4	4874.00	36.5 AV	54.0	-17.5	1.35 V	249	1.00	35.50
5	7311.00	49.5 PK	74.0	-24.5	1.44 V	271	7.50	42.00
6	7311.00	36.6 AV	54.0	-17.4	1.44 V	271	-5.40	42.00

- REMARKS:**
1. Emission level (dBuV/m) = Raw Value (dBuV) + Correction Factor (dB/m).
 2. Correction Factor (dB/m) = Antenna Factor (dB/m) + Cable Factor (dB).
 3. The other emission levels were very low against the limit.
 4. Margin value = Emission level – Limit value.
 5. “ * “: Fundamental frequency.



A D T

EUT TEST CONDITION		MEASUREMENT DETAIL	
CHANNEL	Channel 11	FREQUENCY RANGE	1 ~ 25GHz
INPUT POWER (SYSTEM)	120Vac, 60 Hz	DETECTOR FUNCTION	Peak (PK) Average (AV)
ENVIRONMENTAL CONDITIONS	26deg. C, 67%RH 1011 hPa	TESTED BY	Wen Yu

ANTENNA POLARITY & TEST DISTANCE: HORIZONTAL AT 3 M

NO.	FREQ. (MHz)	EMISSION LEVEL (dBuV/m)	LIMIT (dBuV/m)	MARGIN (dB)	ANTENNA HEIGHT (m)	TABLE ANGLE (Degree)	RAW VALUE (dBuV)	CORRECTION FACTOR (dB/m)
1	*2462.00	96.6 PK			1.34 H	257	66.30	30.30
2	*2462.00	87.3 AV			1.34 H	257	57.00	30.30
3	2483.50	58.1 PK	74.0	-15.9	1.06 H	164	27.70	30.40
4	2483.50	44.1 AV	54.0	-9.9	1.06 H	164	13.70	30.40
5	4924.00	53.4 PK	74.0	-20.6	1.60 H	279	17.80	35.60
6	4924.00	38.4 AV	54.0	-15.6	1.60 H	279	2.80	35.60
7	7386.00	48.3 PK	74.0	-25.7	1.50 H	262	6.20	42.10
8	7386.00	36.7 AV	54.0	-17.3	1.50 H	262	-5.40	42.10

ANTENNA POLARITY & TEST DISTANCE: VERTICAL AT 3 M

NO.	FREQ. (MHz)	EMISSION LEVEL (dBuV/m)	LIMIT (dBuV/m)	MARGIN (dB)	ANTENNA HEIGHT (m)	TABLE ANGLE (Degree)	RAW VALUE (dBuV)	CORRECTION FACTOR (dB/m)
1	*2462.00	97.7 PK			1.40 V	193	67.40	30.30
2	*2462.00	88.4 AV			1.40 V	193	58.10	30.30
3	2483.50	56.9 PK	74.0	-17.1	1.12 V	185	26.50	30.40
4	2483.50	43.6 AV	54.0	-10.4	1.12 V	185	13.20	30.40
5	4924.00	53.8 PK	74.0	-20.2	1.31 V	242	18.20	35.60
6	4924.00	40.0 AV	54.0	-14.0	1.31 V	242	4.40	35.60
7	7386.00	49.5 PK	74.0	-24.5	1.47 V	268	7.40	42.10
8	7386.00	36.5 AV	54.0	-17.5	1.47 V	268	-5.60	42.10

- REMARKS:**
1. Emission level (dBuV/m) = Raw Value (dBuV) + Correction Factor (dB/m).
 2. Correction Factor (dB/m) = Antenna Factor (dB/m) + Cable Factor (dB).
 3. The other emission levels were very low against the limit.
 4. Margin value = Emission level – Limit value.
 5. “ * “: Fundamental frequency.



A D T

RESTRICTED BANDEDGE (802.11n (20MHz) MODE, CH1, HORIZONTAL)

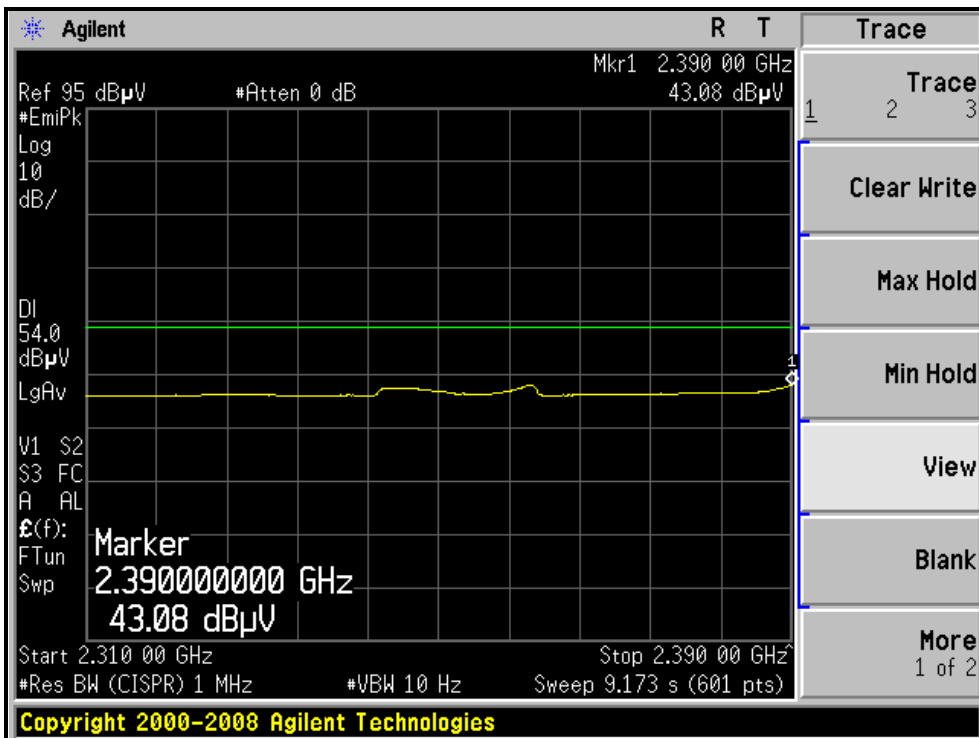
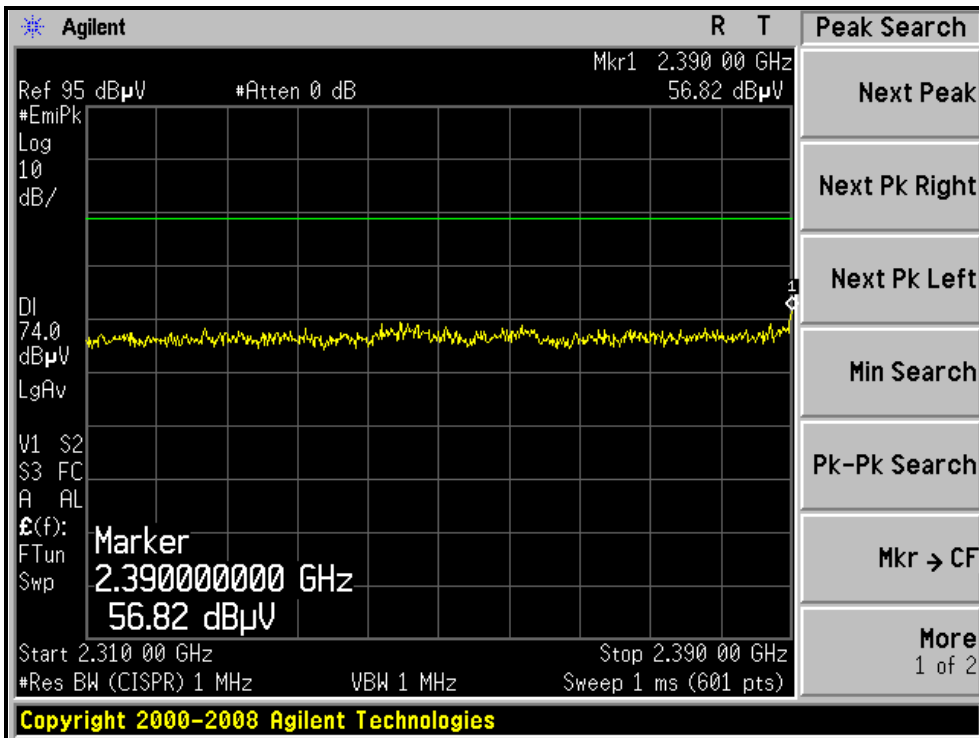



A D T

RESTRICTED BANDEDGE (802.11n (20MHz) MODE,CH1, VERTICAL)

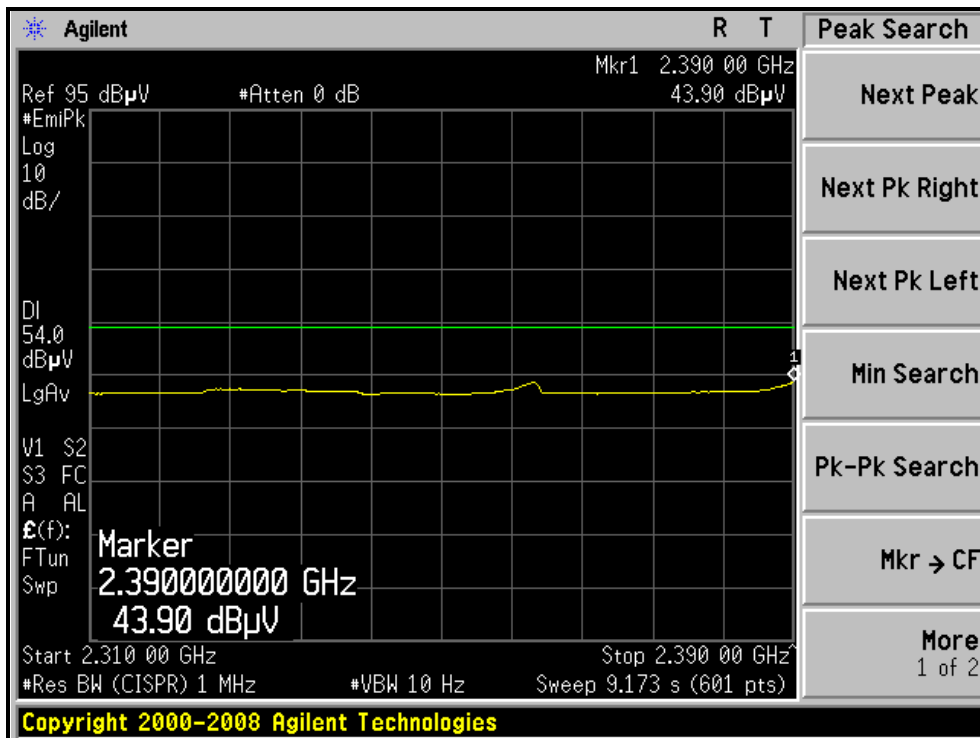
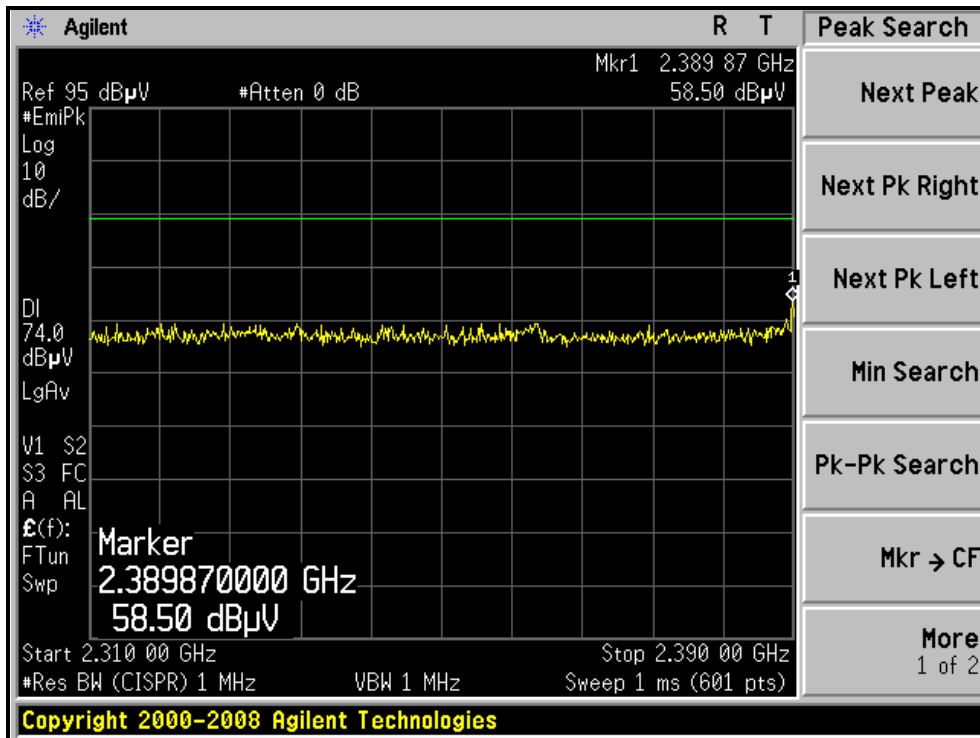



A D T

RESTRICTED BANDEDGE (802.11n (20MHz) MODE, CH11, HORIZONTAL)

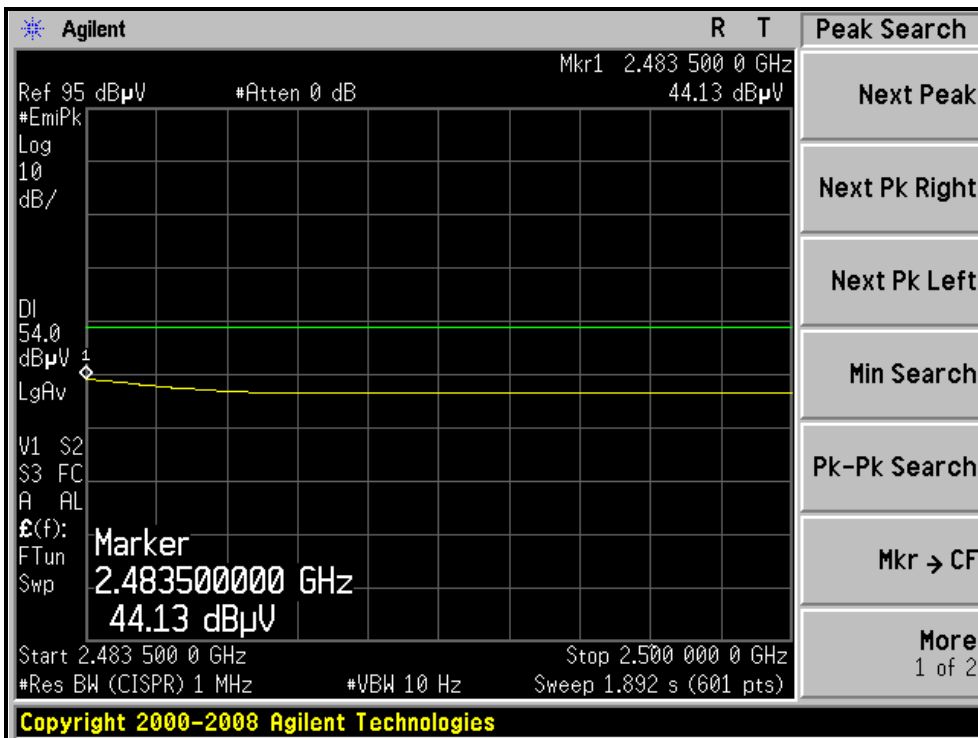
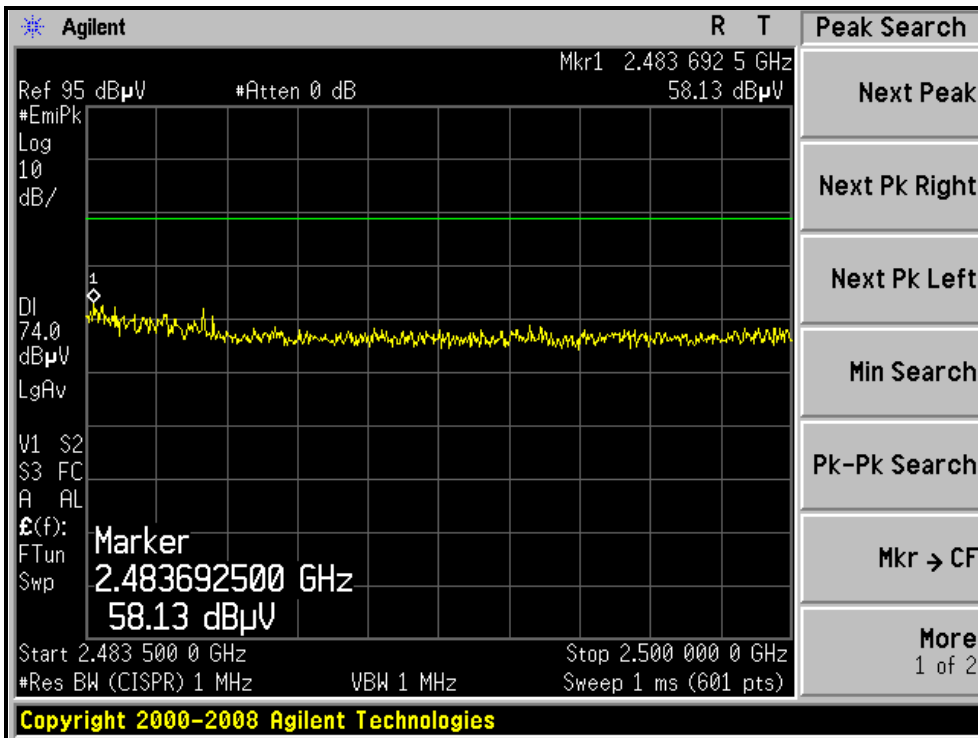



A D T

RESTRICTED BANDEDGE (802.11n (20MHz) MODE,CH11, VERTICAL)

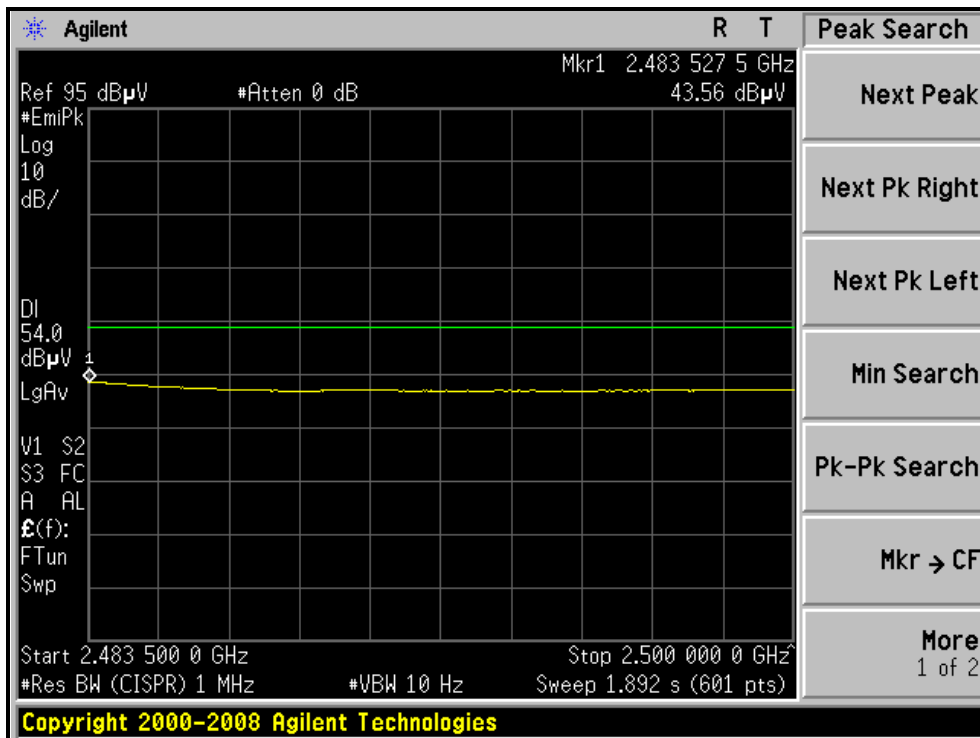
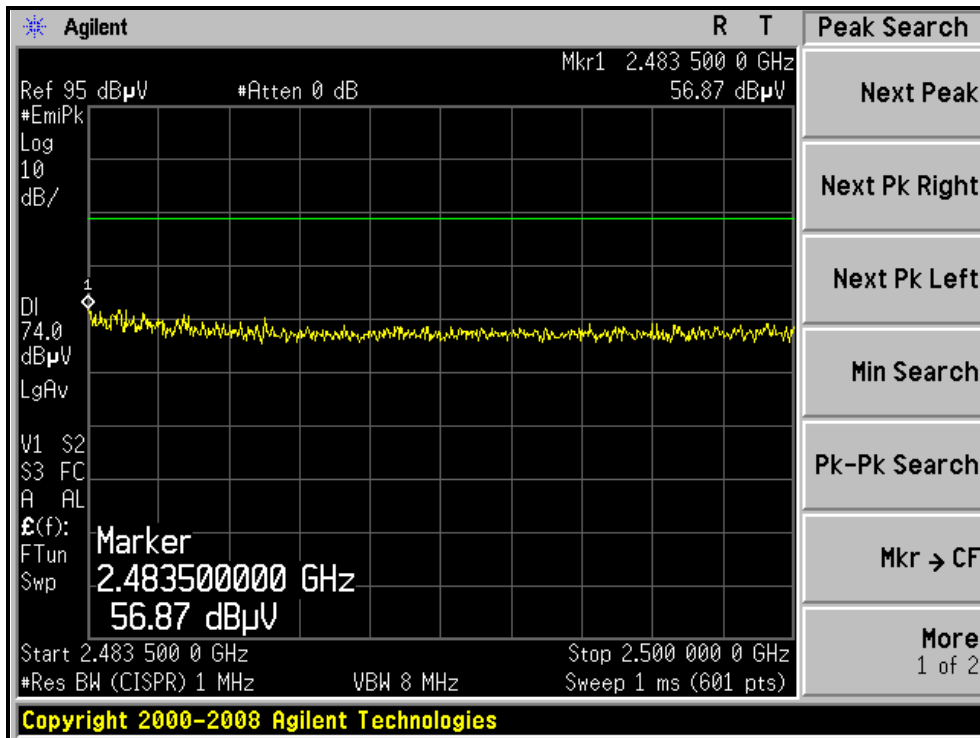



A D T

802.11n (40MHz) OFDM MODULATION

EUT TEST CONDITION		MEASUREMENT DETAIL	
CHANNEL	Channel 1	FREQUENCY RANGE	1 ~ 25GHz
INPUT POWER (SYSTEM)	120Vac, 60 Hz	DETECTOR FUNCTION	Peak (PK) Average (AV)
ENVIRONMENTAL CONDITIONS	26deg. C, 67%RH 1011 hPa	TESTED BY	Wen Yu

ANTENNA POLARITY & TEST DISTANCE: HORIZONTAL AT 3 M								
NO.	FREQ. (MHz)	EMISSION LEVEL (dBuV/m)	LIMIT (dBuV/m)	MARGIN (dB)	ANTENNA HEIGHT (m)	TABLE ANGLE (Degree)	RAW VALUE (dBuV)	CORRECTION FACTOR (dB/m)
1	2390.00	59.5 PK	74.0	-14.5	1.33 H	267	29.40	30.10
2	2390.00	45.3 AV	54.0	-8.7	1.33 H	267	15.20	30.10
3	*2422.00	93.4 PK			1.34 H	285	63.20	30.20
4	*2422.00	84.5 AV			1.34 H	285	54.30	30.20
5	4844.00	46.0 PK	74.0	-28.0	1.58 H	275	10.50	35.50
6	4844.00	35.2 AV	54.0	-18.8	1.58 H	275	-0.30	35.50
7	7266.00	48.6 PK	74.0	-25.4	1.55 H	251	6.70	41.90
8	7266.00	37.3 AV	54.0	-16.7	1.55 H	251	-4.60	41.90
ANTENNA POLARITY & TEST DISTANCE: VERTICAL AT 3 M								
NO.	FREQ. (MHz)	EMISSION LEVEL (dBuV/m)	LIMIT (dBuV/m)	MARGIN (dB)	ANTENNA HEIGHT (m)	TABLE ANGLE (Degree)	RAW VALUE (dBuV)	CORRECTION FACTOR (dB/m)
1	2389.50	64.4 PK	74.0	-9.6	1.10 V	187	34.30	30.10
2	2389.50	49.0 AV	54.0	-5.0	1.10 V	187	18.90	30.10
3	*2422.00	99.3 PK			1.10 V	184	69.10	30.20
4	*2422.00	89.5 AV			1.10 V	184	59.30	30.20
5	4844.00	47.1 PK	74.0	-26.9	1.33 V	255	11.60	35.50
6	4844.00	35.6 AV	54.0	-18.4	1.33 V	255	0.10	35.50
7	7266.00	50.3 PK	74.0	-23.7	1.45 V	269	8.40	41.90
8	7266.00	37.6 AV	54.0	-16.4	1.45 V	269	-4.30	41.90

- REMARKS:**
1. Emission level (dBuV/m) = Raw Value (dBuV) + Correction Factor (dB/m).
 2. Correction Factor (dB/m) = Antenna Factor (dB/m) + Cable Factor (dB).
 3. The other emission levels were very low against the limit.
 4. Margin value = Emission level – Limit value.
 5. “ * “: Fundamental frequency.



A D T

EUT TEST CONDITION		MEASUREMENT DETAIL	
CHANNEL	Channel 4	FREQUENCY RANGE	1 ~ 25GHz
INPUT POWER (SYSTEM)	120Vac, 60 Hz	DETECTOR FUNCTION	Peak (PK) Average (AV)
ENVIRONMENTAL CONDITIONS	26deg. C, 67%RH 1011 hPa	TESTED BY	Wen Yu

ANTENNA POLARITY & TEST DISTANCE: HORIZONTAL AT 3 M								
NO.	FREQ. (MHz)	EMISSION LEVEL (dBuV/m)	LIMIT (dBuV/m)	MARGIN (dB)	ANTENNA HEIGHT (m)	TABLE ANGLE (Degree)	RAW VALUE (dBuV)	CORRECTION FACTOR (dB/m)
1	*2437.00	93.9 PK			1.35 H	285	63.70	30.20
2	*2437.00	84.7 AV			1.35 H	285	54.50	30.20
3	4874.00	52.2 PK	74.0	-21.8	1.59 H	279	16.70	35.50
4	4874.00	41.4 AV	54.0	-12.6	1.59 H	279	5.90	35.50
5	7311.00	48.4 PK	74.0	-25.6	1.51 H	265	6.40	42.00
6	7311.00	36.9 AV	54.0	-17.1	1.51 H	265	-5.10	42.00
ANTENNA POLARITY & TEST DISTANCE: VERTICAL AT 3 M								
NO.	FREQ. (MHz)	EMISSION LEVEL (dBuV/m)	LIMIT (dBuV/m)	MARGIN (dB)	ANTENNA HEIGHT (m)	TABLE ANGLE (Degree)	RAW VALUE (dBuV)	CORRECTION FACTOR (dB/m)
1	*2437.00	96.9 PK			1.11 V	184	66.70	30.20
2	*2437.00	87.7 AV			1.11 V	184	57.50	30.20
3	4874.00	49.5 PK	74.0	-24.5	1.36 V	251	14.00	35.50
4	4874.00	36.7 AV	54.0	-17.3	1.36 V	251	1.20	35.50
5	7311.00	50.1 PK	74.0	-23.9	1.44 V	267	8.10	42.00
6	7311.00	37.2 AV	54.0	-16.8	1.44 V	267	-4.80	42.00

- REMARKS:**
1. Emission level (dBuV/m) = Raw Value (dBuV) + Correction Factor (dB/m).
 2. Correction Factor (dB/m) = Antenna Factor (dB/m) + Cable Factor (dB).
 3. The other emission levels were very low against the limit.
 4. Margin value = Emission level – Limit value.
 5. “ * “: Fundamental frequency.



A D T

EUT TEST CONDITION		MEASUREMENT DETAIL	
CHANNEL	Channel 7	FREQUENCY RANGE	1 ~ 25GHz
INPUT POWER (SYSTEM)	120Vac, 60 Hz	DETECTOR FUNCTION	Peak (PK) Average (AV)
ENVIRONMENTAL CONDITIONS	26deg. C, 67%RH 1011 hPa	TESTED BY	Wen Yu

ANTENNA POLARITY & TEST DISTANCE: HORIZONTAL AT 3 M								
NO.	FREQ. (MHz)	EMISSION LEVEL (dBuV/m)	LIMIT (dBuV/m)	MARGIN (dB)	ANTENNA HEIGHT (m)	TABLE ANGLE (Degree)	RAW VALUE (dBuV)	CORRECTION FACTOR (dB/m)
1	*2452.00	92.6 PK			1.34 H	259	62.30	30.30
2	*2452.00	83.0 AV			1.34 H	259	52.70	30.30
3	2483.50	55.4 PK	74.0	-18.6	1.32 H	184	25.00	30.40
4	2483.50	43.0 AV	54.0	-11.0	1.32 H	184	12.60	30.40
5	4904.00	48.8 PK	74.0	-25.2	1.59 H	276	13.20	35.60
6	4904.00	37.9 AV	54.0	-16.1	1.59 H	276	2.30	35.60
7	7356.00	48.4 PK	74.0	-25.6	1.54 H	262	6.40	42.00
8	7356.00	36.6 AV	54.0	-17.4	1.54 H	262	-5.40	42.00
ANTENNA POLARITY & TEST DISTANCE: VERTICAL AT 3 M								
NO.	FREQ. (MHz)	EMISSION LEVEL (dBuV/m)	LIMIT (dBuV/m)	MARGIN (dB)	ANTENNA HEIGHT (m)	TABLE ANGLE (Degree)	RAW VALUE (dBuV)	CORRECTION FACTOR (dB/m)
1	*2452.00	98.3 PK			1.10 V	186	68.00	30.30
2	*2452.00	88.8 AV			1.10 V	186	58.50	30.30
3	2483.50	58.5 PK	74.0	-15.5	1.04 V	182	28.10	30.40
4	2483.50	47.1 AV	54.0	-6.9	1.04 V	182	16.70	30.40
5	4904.00	53.6 PK	74.0	-20.4	1.39 V	250	18.00	35.60
6	4904.00	43.4 AV	54.0	-10.6	1.39 V	250	7.80	35.60
7	7356.00	49.4 PK	74.0	-24.6	1.45 V	269	7.40	42.00
8	7356.00	36.5 AV	54.0	-17.5	1.45 V	269	-5.50	42.00

- REMARKS:**
1. Emission level (dBuV/m) = Raw Value (dBuV) + Correction Factor (dB/m).
 2. Correction Factor (dB/m) = Antenna Factor (dB/m) + Cable Factor (dB).
 3. The other emission levels were very low against the limit.
 4. Margin value = Emission level – Limit value.
 5. “ * “: Fundamental frequency.



A D T

RESTRICTED BANDEDGE (802.11n (40MHz) MODE,CH1, HORIZONTAL)

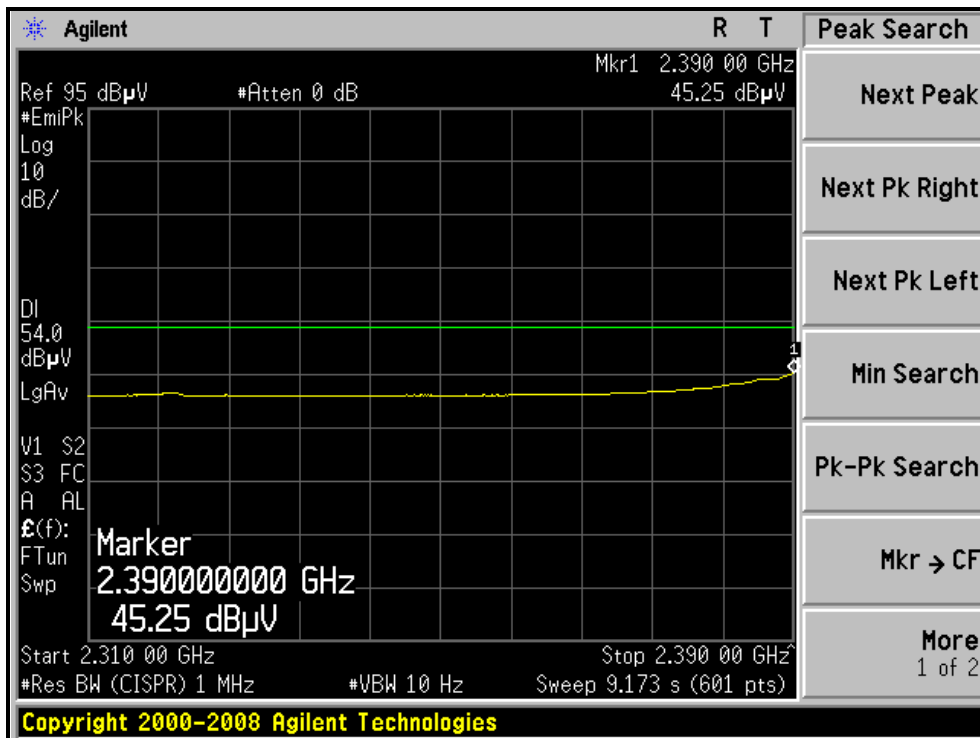
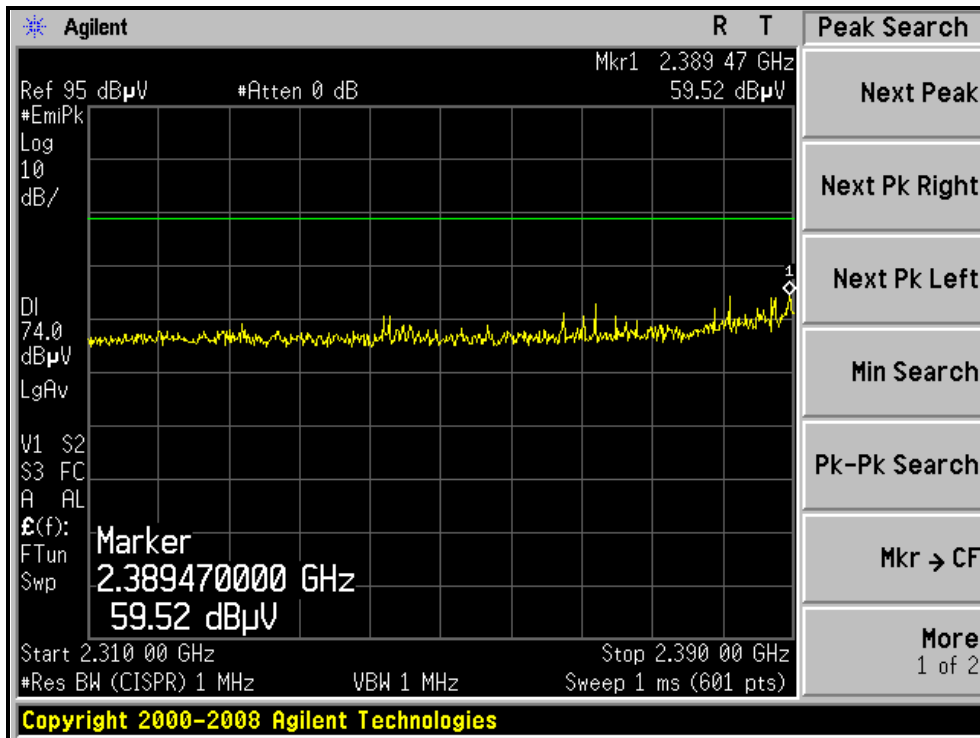



A D T

RESTRICTED BANDEDGE (802.11n (40MHz) MODE,CH1, VERTICAL)

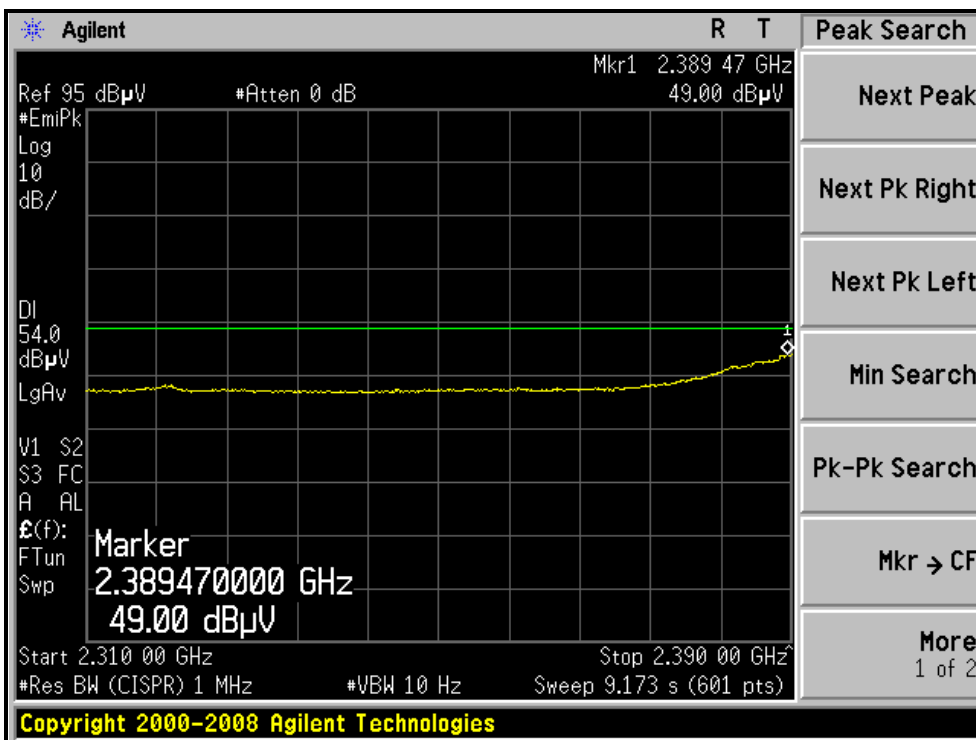
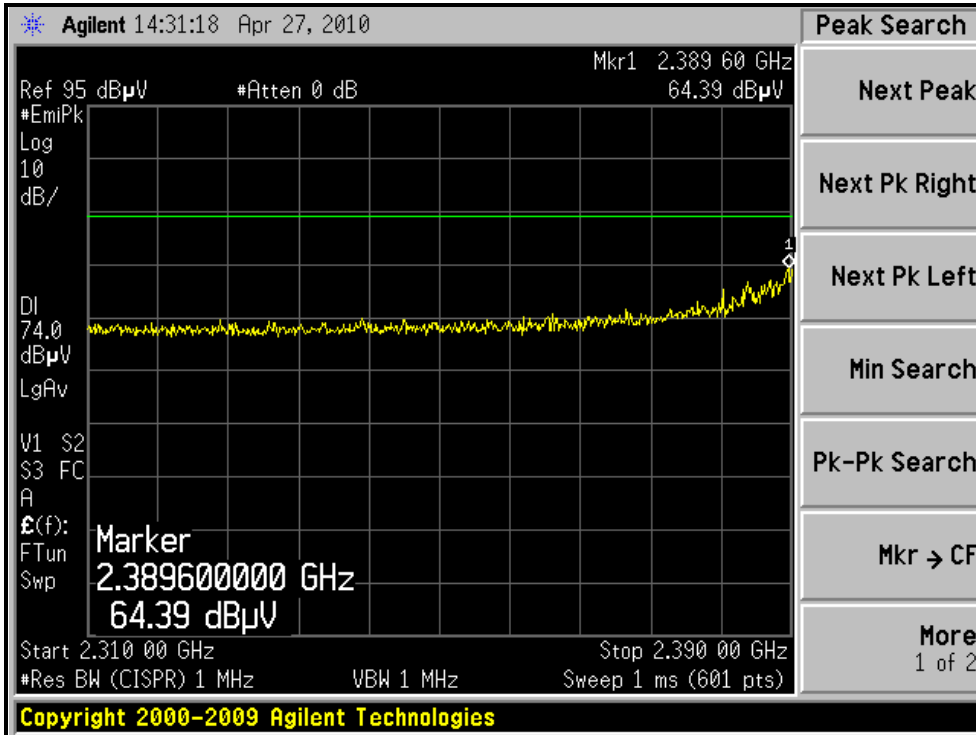



A D T

RESTRICTED BANDEDGE (802.11n (40MHz) MODE,CH7, HORIZONTAL)

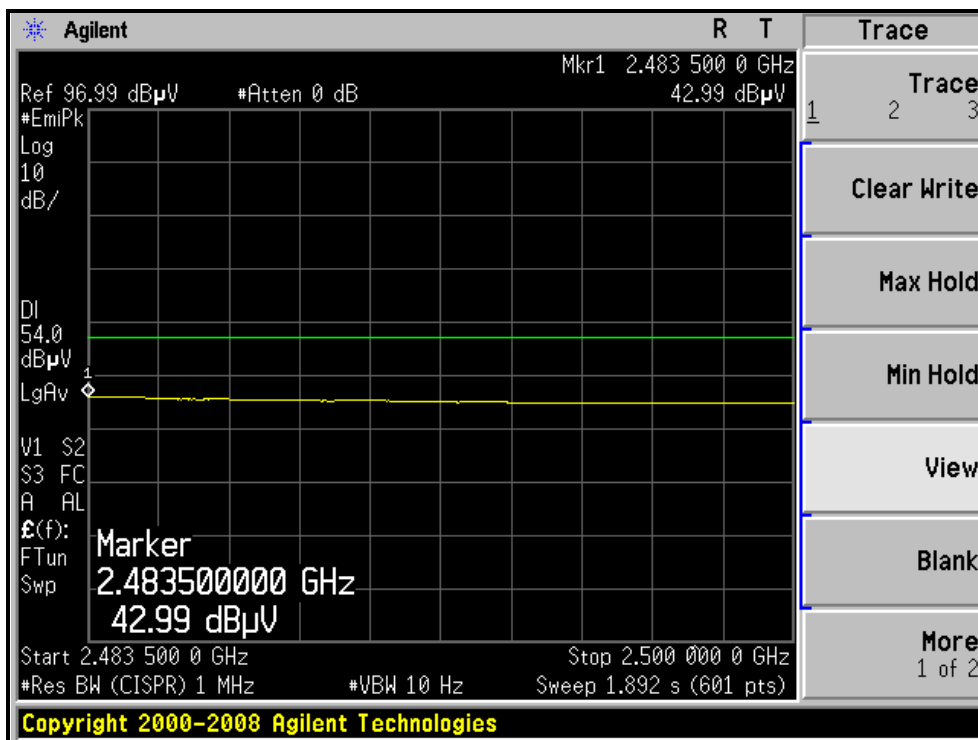
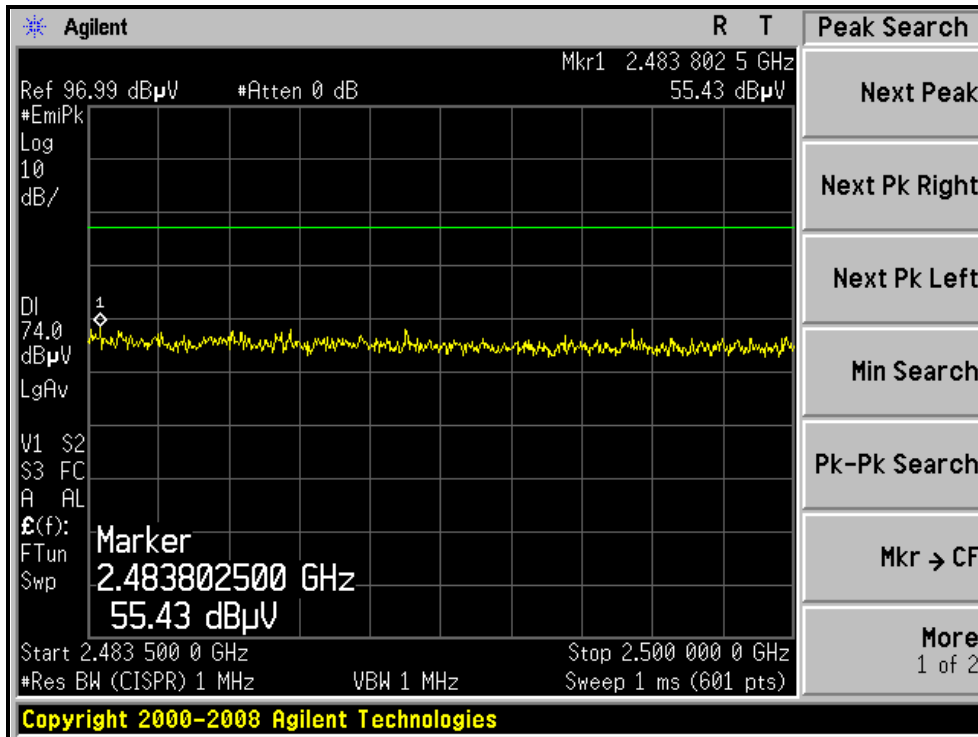



A D T

RESTRICTED BANDEDGE (802.11n (40MHz) MODE,CH7, VERTICAL)

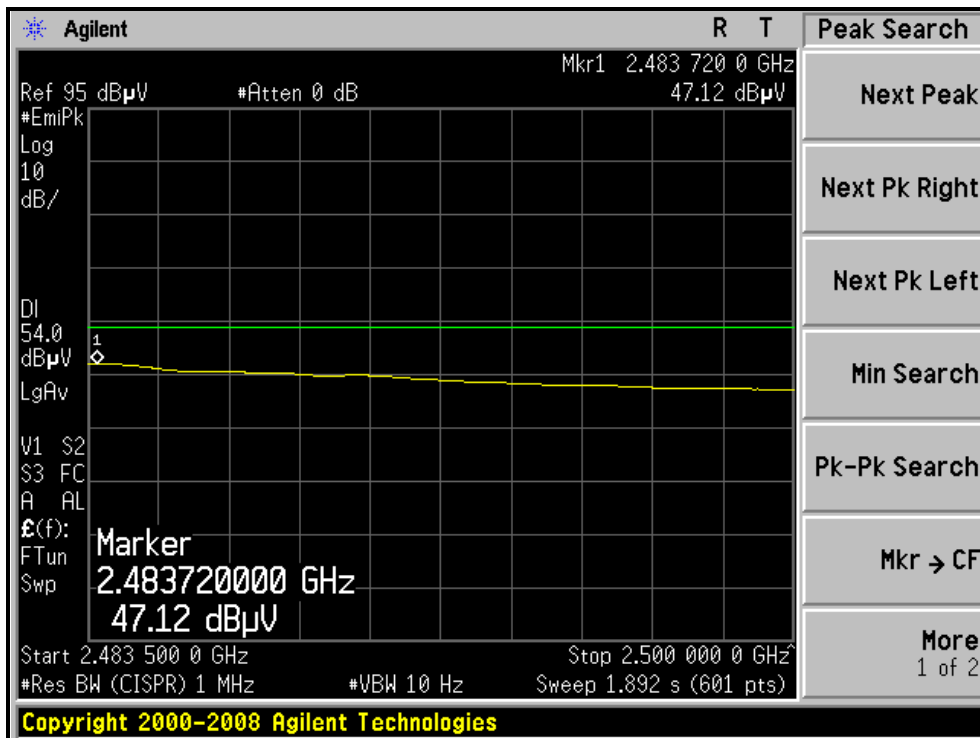
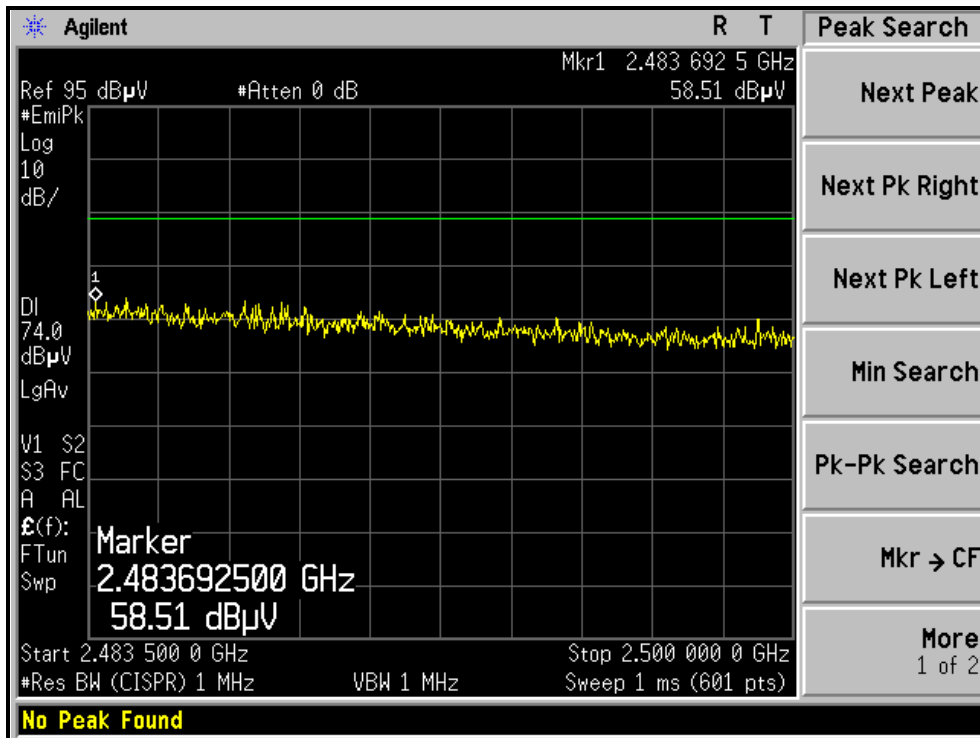

4.3 6dB BANDWIDTH MEASUREMENT

4.3.1 LIMITS OF 6dB BANDWIDTH MEASUREMENT

The minimum of 6dB Bandwidth Measurement is 0.5 MHz.

4.3.2 TEST INSTRUMENTS

DESCRIPTION & MANUFACTURER	MODEL NO.	SERIAL NO.	CALIBRATED DATE	CALIBRATED UNTIL
R&S SPECTRUM ANALYZER	FSP40	100037	Aug. 03, 2009	Aug. 02, 2010

NOTE:

1. The calibration interval of the above test instruments is 12 months and the calibrations are traceable to NML/ROC and NIST/USA.

4.3.3 TEST PROCEDURE

The transmitter output was connected to the spectrum analyzer through an attenuator. The bandwidth of the fundamental frequency was measured by spectrum analyzer with 100kHz RBW and 100kHz VBW. The 6dB bandwidth is defined as the total spectrum the power of which is higher than peak power minus 6dB.

4.3.4 DEVIATION FROM TEST STANDARD

No deviation

4.3.5 TEST SETUP



4.3.6 EUT OPERATING CONDITIONS

The software provided by client to enable the EUT under transmission condition continuously at lowest, middle and highest channel frequencies individually.



A D T

4.3.7 TEST RESULTS

802.11b DSSS MODULATION:

CHANNEL	CHANNEL FREQUENCY (MHz)	6dB BANDWIDTH (MHz)	MINIMUM LIMIT (MHz)	PASS / FAIL
1	2412	11.27	0.5	PASS
6	2437	11.24	0.5	PASS
11	2462	11.24	0.5	PASS

CH1

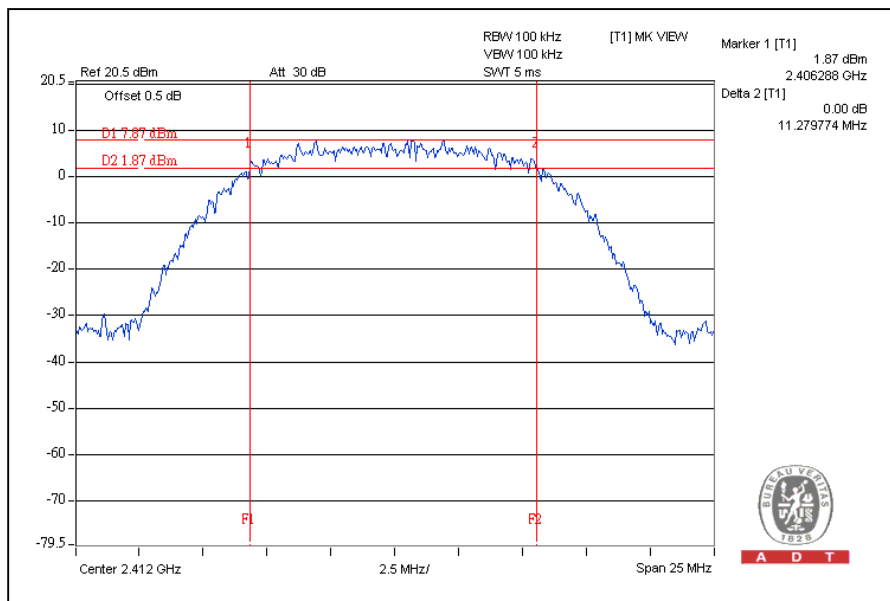



A D T

802.11g OFDM MODULATION:

CHANNEL	CHANNEL FREQUENCY (MHz)	6dB BANDWIDTH (MHz)	MINIMUM LIMIT (MHz)	PASS / FAIL
1	2412	16.58	0.5	PASS
6	2437	16.55	0.5	PASS
11	2462	16.53	0.5	PASS

CH1

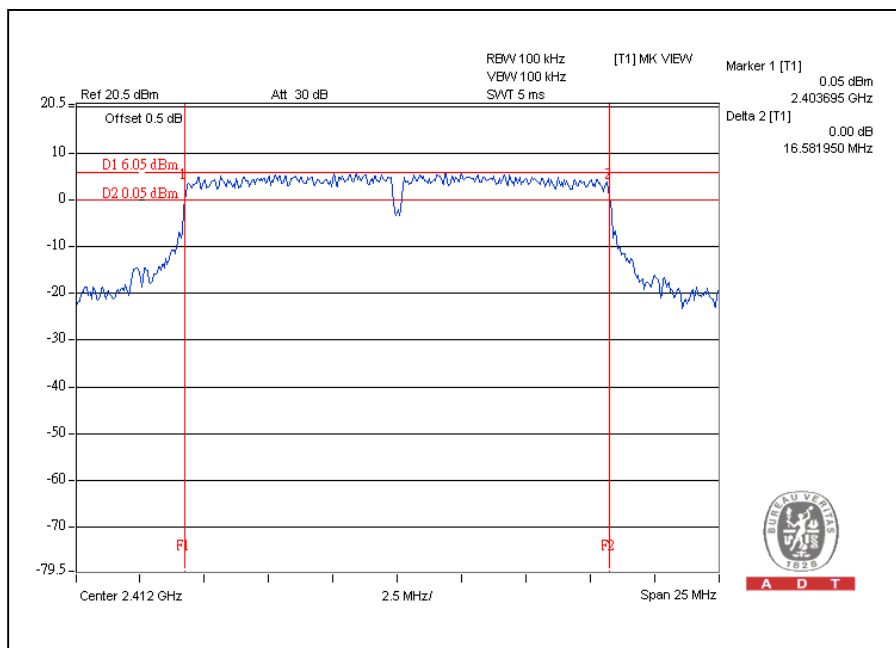



A D T

802.11n (20MHz) OFDM MODULATION:

CHANNEL	CHANNEL FREQUENCY (MHz)	6dB BANDWIDTH (MHz)	MINIMUM LIMIT (MHz)	PASS / FAIL
1	2412	17.75	0.5	PASS
6	2437	17.72	0.5	PASS
11	2462	17.73	0.5	PASS

CH1

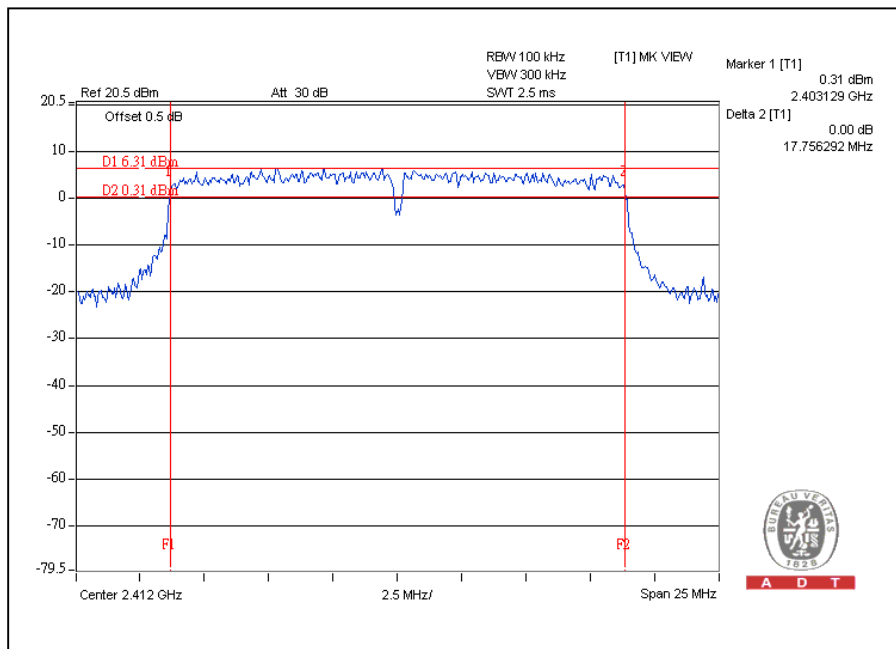



A D T

802.11n (40MHz) OFDM MODULATION:

CHANNEL	CHANNEL FREQUENCY (MHz)	6dB BANDWIDTH (MHz)	MINIMUM LIMIT (MHz)	PASS / FAIL
1	2422	36.52	0.5	PASS
4	2437	36.54	0.5	PASS
7	2452	36.52	0.5	PASS

CH4

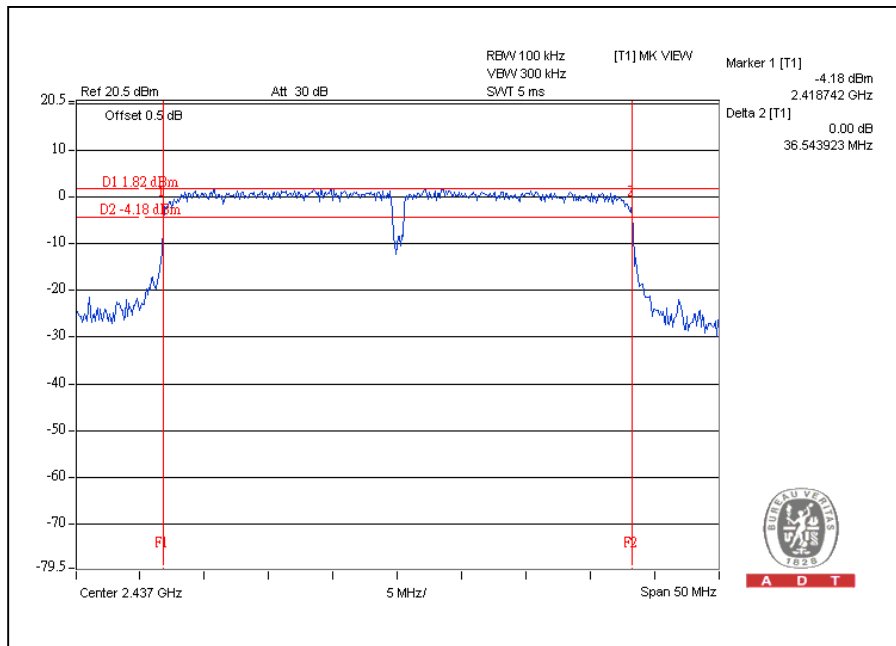

4.4 MAXIMUM PEAK OUTPUT POWER

4.4.1 LIMITS OF MAXIMUM PEAK OUTPUT POWER MEASUREMENT

The Maximum Peak Output Power Measurement is 30dBm.

4.4.2 INSTRUMENTS

DESCRIPTION & MANUFACTURER	MODEL NO.	SERIAL NO.	CALIBRATED DATE	CALIBRATED UNTIL
Anritsu Power Meter	ML2495A	0824006	April 24, 2010	April 23, 2011
Pulse Power Sensor	MA2411B	0738172	April 24, 2010	April 23, 2011

NOTE:

The calibration interval of the above test instruments is 12 months and the calibrations are traceable to NML/ROC and NIST/USA.

4.4.3 TEST PROCEDURES

1. The transmitter output was connected to the power meter through an attenuator; the bandwidth of the fundamental frequency was measured with the power meter.
2. Record the power level.

4.4.4 DEVIATION FROM TEST STANDARD

No deviation

4.4.5 TEST SETUP

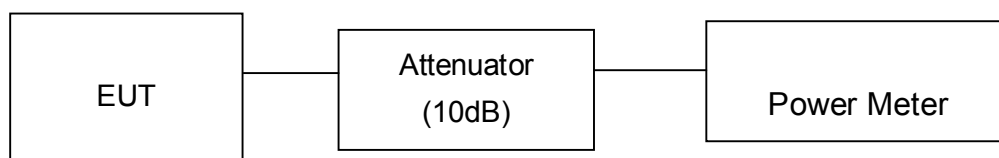

4.4.6 EUT OPERATING CONDITIONS

Same as Item 4.3.6



4.4.7 TEST RESULTS

802.11b DSSS MODULATION:

CHANNEL	CHANNEL FREQUENCY (MHz)	PEAK POWER OUTPUT (dBm)	PEAK POWER OUTPUT (mW)	PEAK POWER LIMIT (dBm)	PASS / FAIL
1	2412	20.7	117.5	30	PASS
6	2437	20.6	114.8	30	PASS
11	2462	20.7	117.5	30	PASS

802.11g OFDM MODULATION:

CHANNEL	CHANNEL FREQUENCY (MHz)	PEAK POWER OUTPUT (dBm)	PEAK POWER OUTPUT (mW)	PEAK POWER LIMIT (dBm)	PASS / FAIL
1	2412	26.3	426.6	30	PASS
6	2437	26.3	426.6	30	PASS
11	2462	26.4	436.5	30	PASS

802.11n (20MHz) OFDM MODULATION:

CHANNEL	CHANNEL FREQUENCY (MHz)	PEAK POWER OUTPUT (dBm)	PEAK POWER OUTPUT (mW)	PEAK POWER LIMIT (dBm)	PASS / FAIL
1	2412	26.4	436.5	30	PASS
6	2437	26.5	446.7	30	PASS
11	2462	26.4	436.5	30	PASS



802.11n (40MHz) OFDM MODULATION:

CHANNEL	CHANNEL FREQUENCY (MHz)	PEAK POWER OUTPUT (dBm)	PEAK POWER OUTPUT (mW)	PEAK POWER LIMIT (dBm)	PASS / FAIL
1	2422	26.4	436.5	30	PASS
4	2437	26.5	446.7	30	PASS
7	2452	26.6	457.1	30	PASS

4.5 POWER SPECTRAL DENSITY MEASUREMENT

4.5.1 LIMITS OF POWER SPECTRAL DENSITY MEASUREMENT

The Maximum of Power Spectral Density Measurement is 8dBm.

4.5.2 TEST INSTRUMENTS

DESCRIPTION & MANUFACTURER	MODEL NO.	SERIAL NO.	CALIBRATED DATE	CALIBRATED UNTIL
R&S SPECTRUM ANALYZER	FSP40	100037	Aug. 03, 2009	Aug. 02, 2010

NOTE:

1. The calibration interval of the above test instruments is 12 months and the calibrations are traceable to NML/ROC and NIST/USA.

4.5.3 TEST PROCEDURE

The transmitter output was connected to the spectrum analyzer through an attenuator, the bandwidth of the fundamental frequency was measured with the spectrum analyzer using 3kHz RBW and 30kHz VBW, set sweep time = span/3kHz. The power spectral density was measured and recorded.

The sweep time is allowed to be longer than span/3kHz for a full response of the mixer in the spectrum analyzer.

4.5.4 DEVIATION FROM TEST STANDARD

No deviation

4.5.5 TEST SETUP

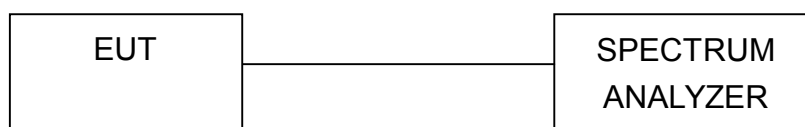

4.5.6 EUT OPERATING CONDITION

Same as Item 4.3.6



A D T

4.5.7 TEST RESULTS

802.11b DSSS MODULATION:

CHANNEL	CHANNEL FREQUENCY (MHz)	RF POWER LEVEL IN 3kHz BW (dBm)	MAXIMUM LIMIT (dBm)	PASS / FAIL
1	2412	-4.8	8	PASS
6	2437	-4.8	8	PASS
11	2462	-6.5	8	PASS

CH1

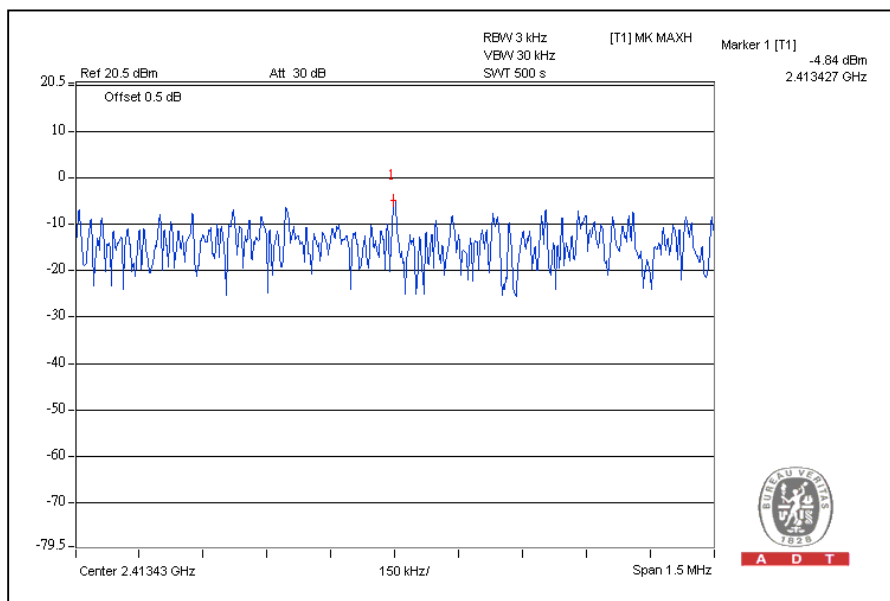



A D T

802.11g OFDM MODULATION:

CHANNEL	CHANNEL FREQUENCY (MHz)	RF POWER LEVEL IN 3kHz BW (dBm)	MAXIMUM LIMIT (dBm)	PASS / FAIL
1	2412	-8.0	8	PASS
6	2437	-8.4	8	PASS
11	2462	-8.0	8	PASS

CH11

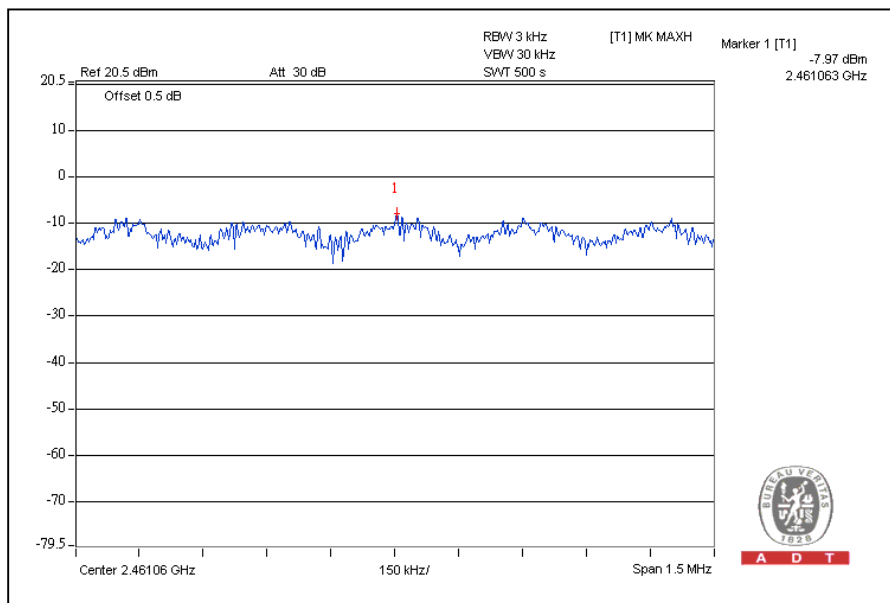



A D T

802.11n (20MHz) OFDM MODULATION:

CHANNEL	CHANNEL FREQUENCY (MHz)	RF POWER LEVEL IN 3kHz BW (dBm)	MAXIMUM LIMIT (dBm)	PASS / FAIL
1	2412	-8.6	8	PASS
6	2437	-9.1	8	PASS
11	2462	-7.1	8	PASS

CH11

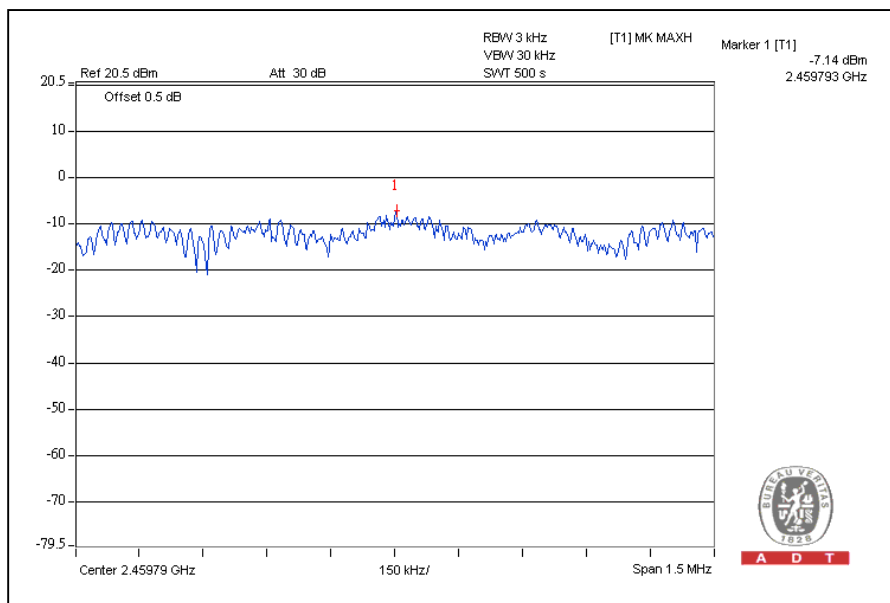



A D T

802.11n (40MHz) OFDM MODULATION:

CHANNEL	CHANNEL FREQUENCY (MHz)	RF POWER LEVEL IN 3kHz BW (dBm)	MAXIMUM LIMIT (dBm)	PASS / FAIL
1	2422	-12.1	8	PASS
4	2437	-10.0	8	PASS
7	2452	-12.3	8	PASS

CH4

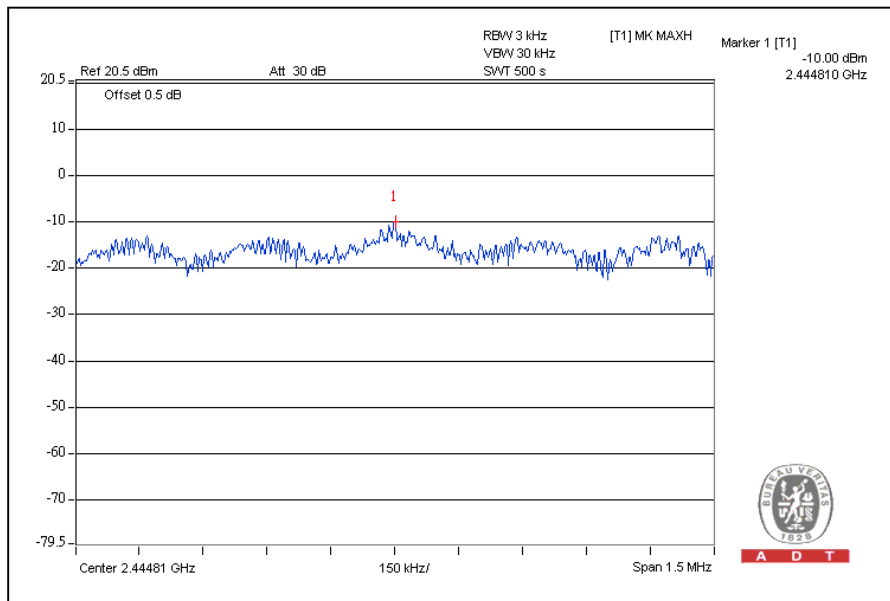

4.6 CONDUCTED OUT-BAND EMISSION MEASUREMENT

4.6.1 LIMITS OF CONDUCTED OUT-BAND EMISSION MEASUREMENT

Below -20dB of the highest emission level of operating band (in 100kHz Resolution Bandwidth).

4.6.2 TEST INSTRUMENTS

DESCRIPTION & MANUFACTURER	MODEL NO.	SERIAL NO.	CALIBRATED DATE	CALIBRATED UNTIL
R&S SPECTRUM ANALYZER	FSP40	100037	Aug. 03, 2009	Aug. 02, 2010

NOTE:

1. The calibration interval of the above test instruments is 12 months and the calibrations are traceable to NML/ROC and NIST/USA.

4.6.3 TEST PROCEDURE

The transmitter output was connected to the spectrum analyzer via a low loss cable. Set RBW of spectrum analyzer to 100kHz and VBW of spectrum analyzer to 300kHz with suitable frequency span including 100 MHz bandwidth from band edge. The band edges was measured and recorded.

The spectrum plots (RBW = 100kHz, VBW = 300kHz) are attached on the following pages.

4.6.4 DEVIATION FROM TEST STANDARD

No deviation

4.6.5 EUT OPERATING CONDITION

Same as Item 4.3.6

4.6.6 TEST RESULTS

The spectrum plots are attached on the following images. D1 line indicates the highest level, and D2 line indicates the 20dB offset below D1. It shows compliance with the requirement in part 15.247(d).

802.11b DSSS MODULATION:

CH1

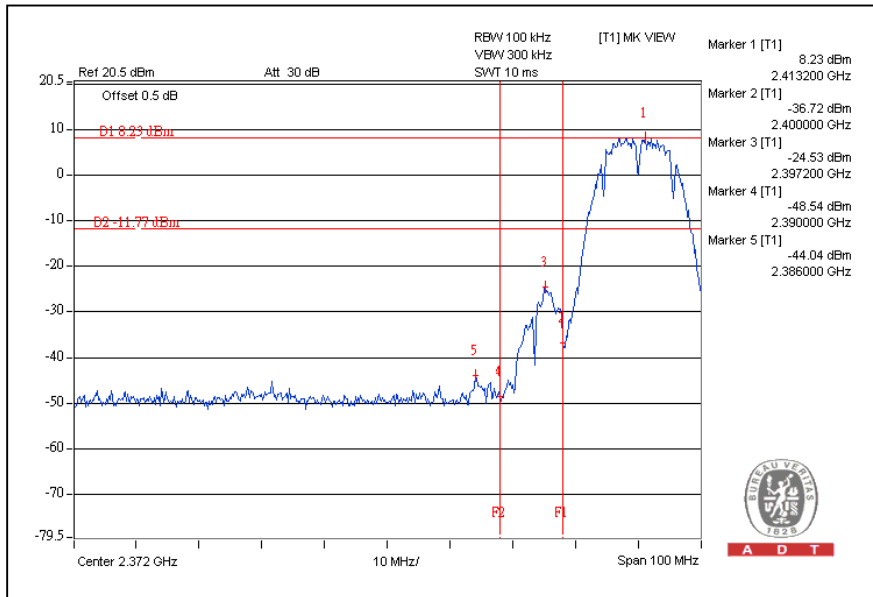

CH11

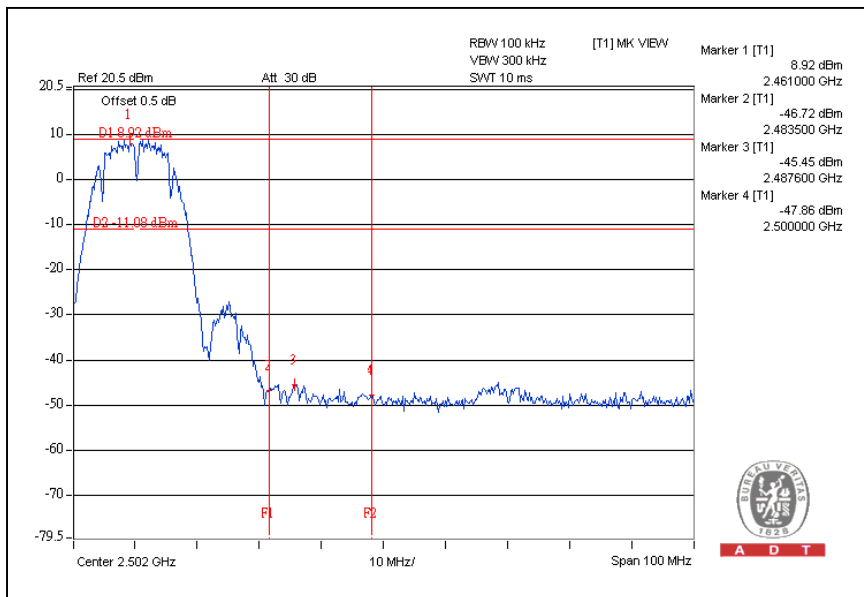



A D T

CH1

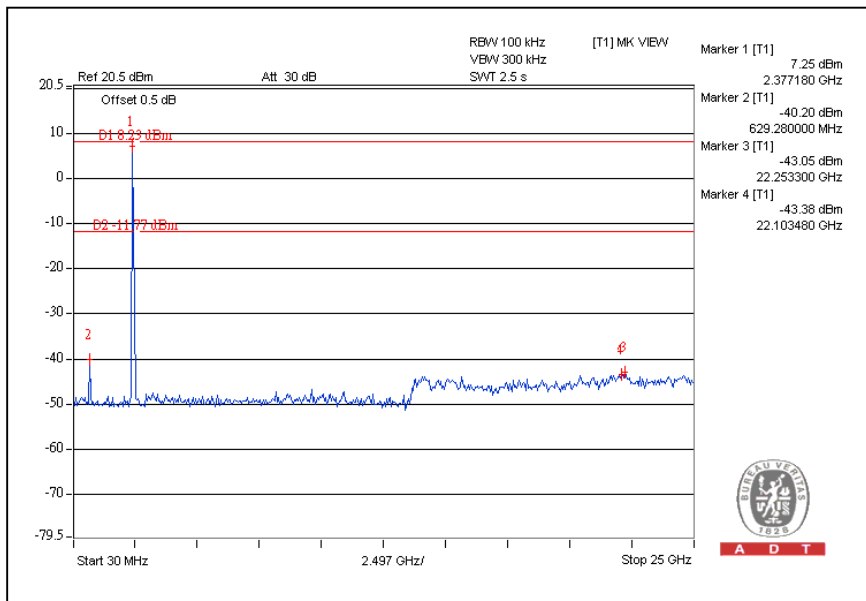

CH11

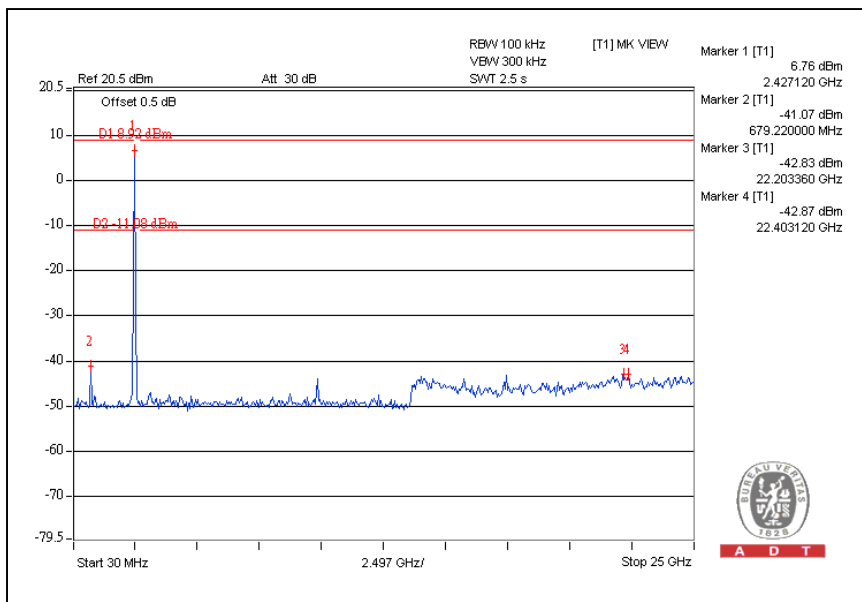

802.11g OFDM MODULATION:

CH1

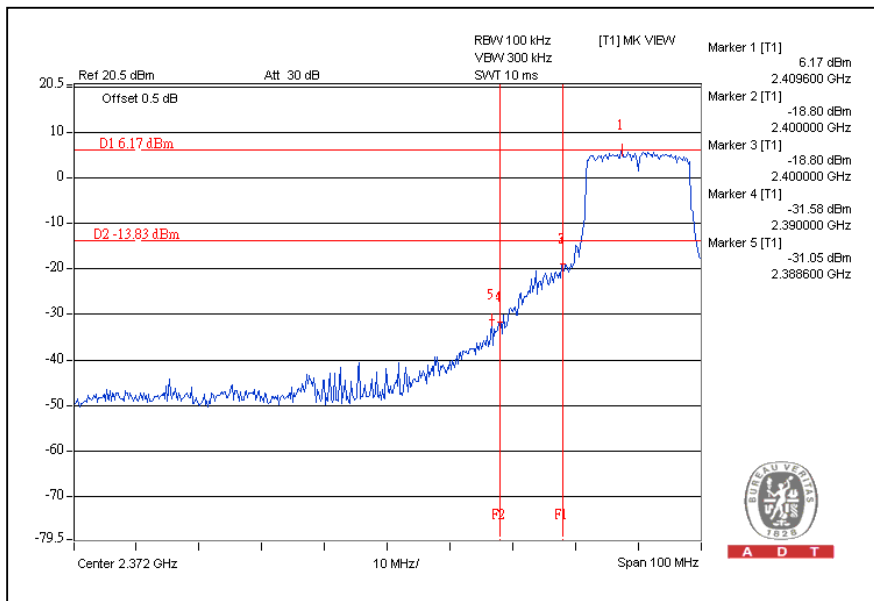

CH11

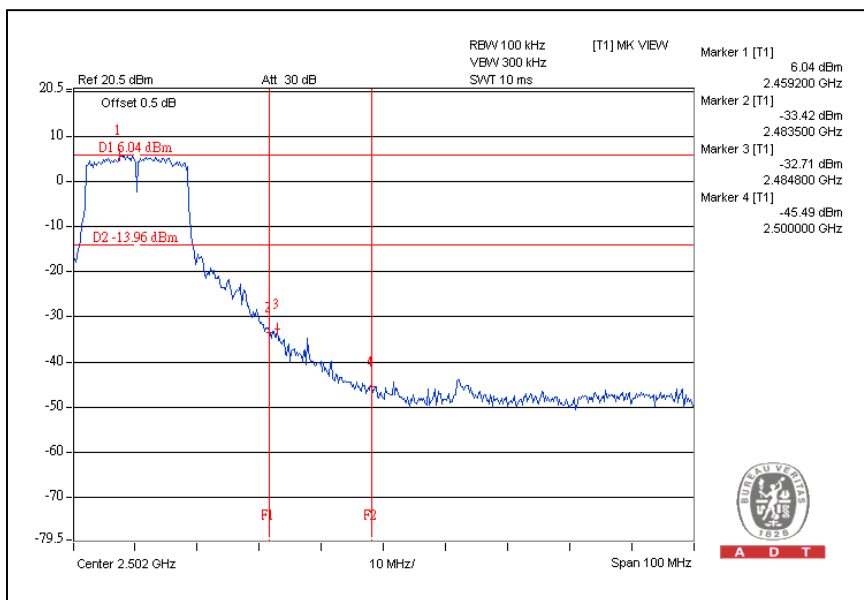



A D T

CH1

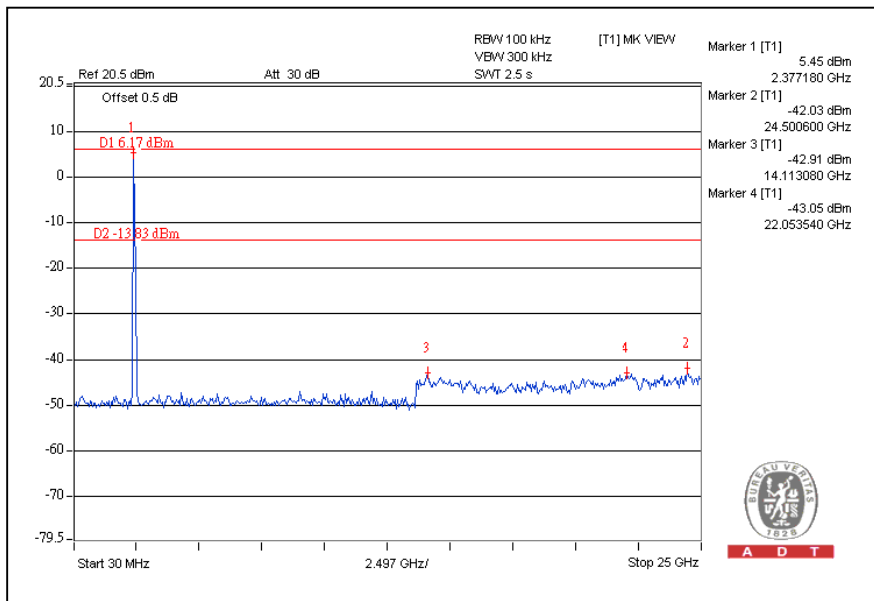

CH11

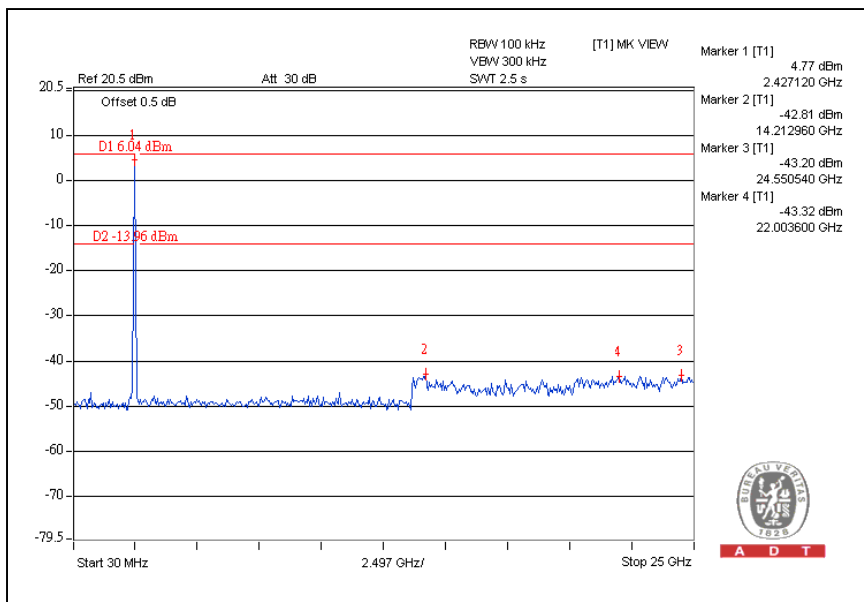

802.11n (20MHz) OFDM MODULATION:

CH1

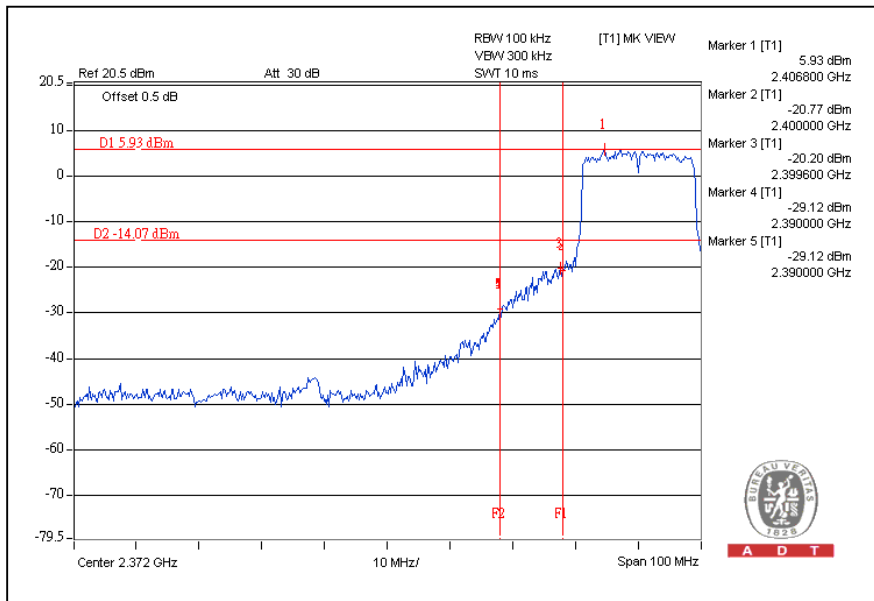

CH11

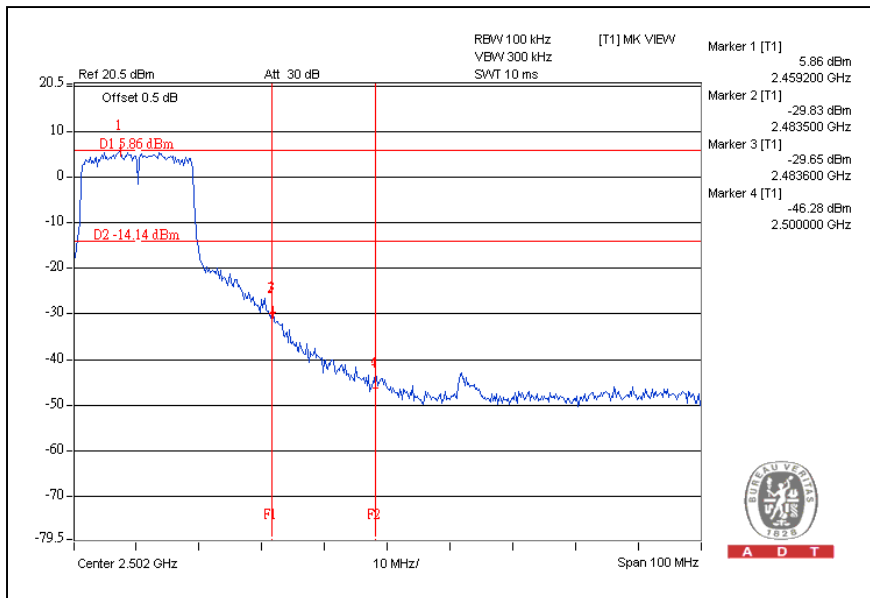



A D T

CH1

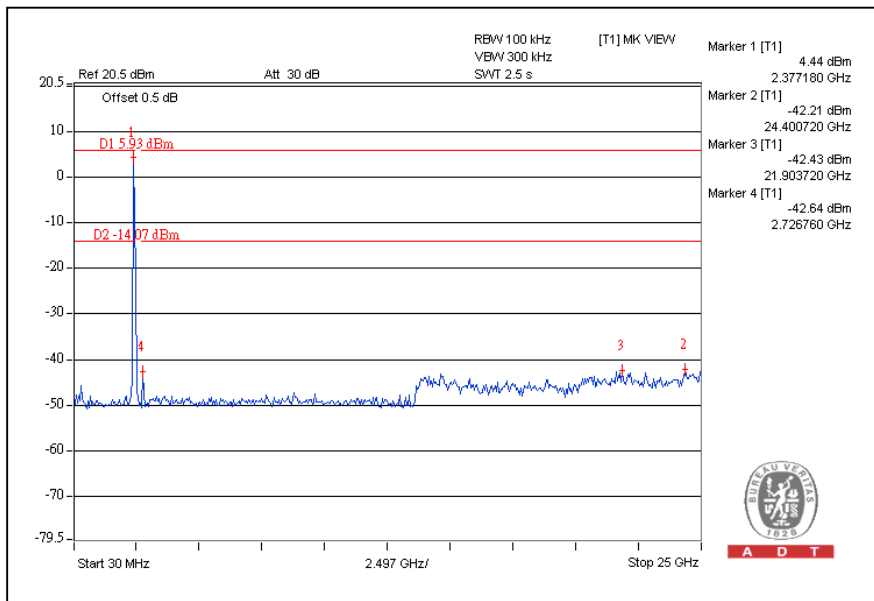

CH11

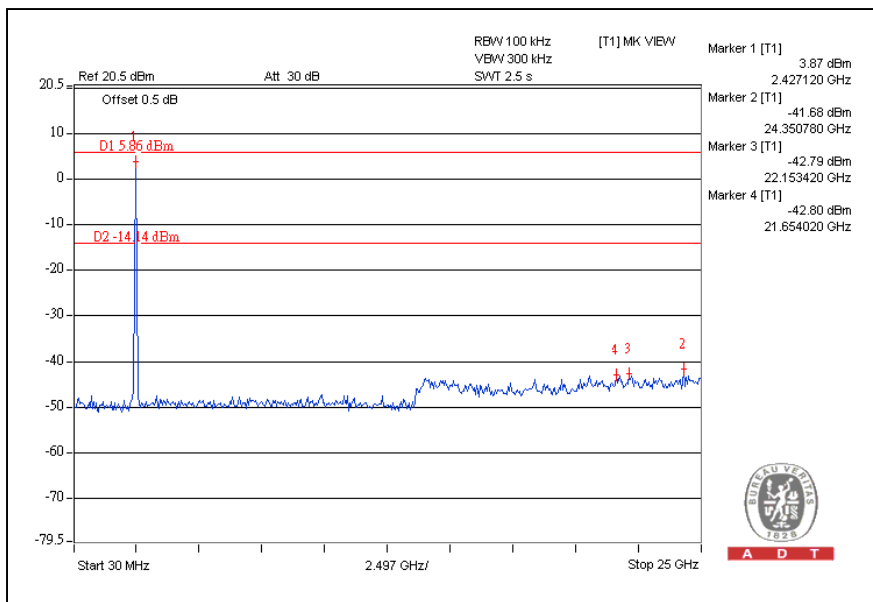

802.11n (40MHz) OFDM MODULATION:

CH1

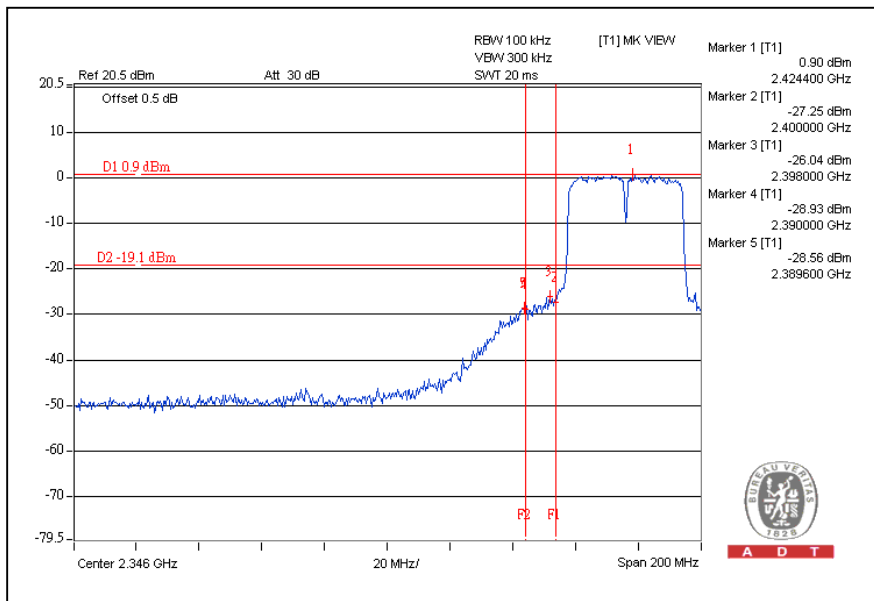

CH7

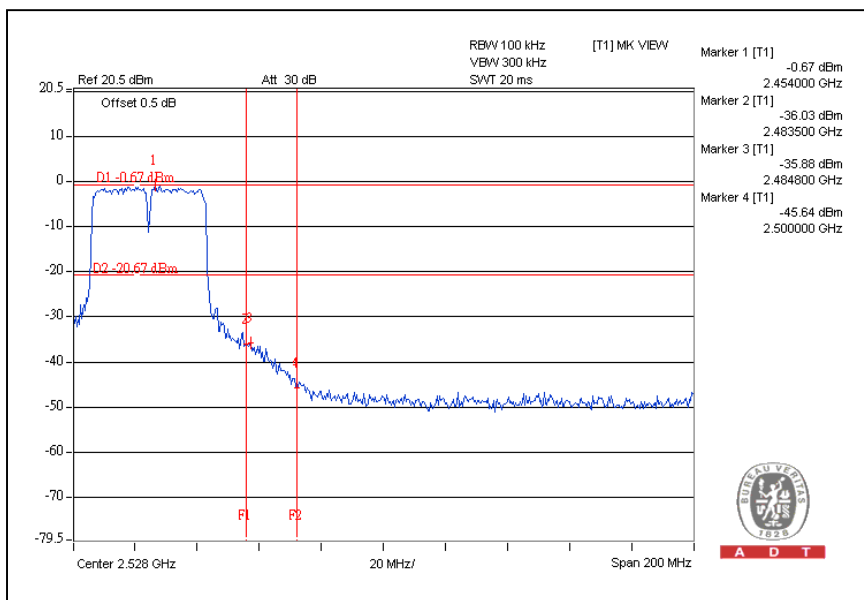



A D T

CH1

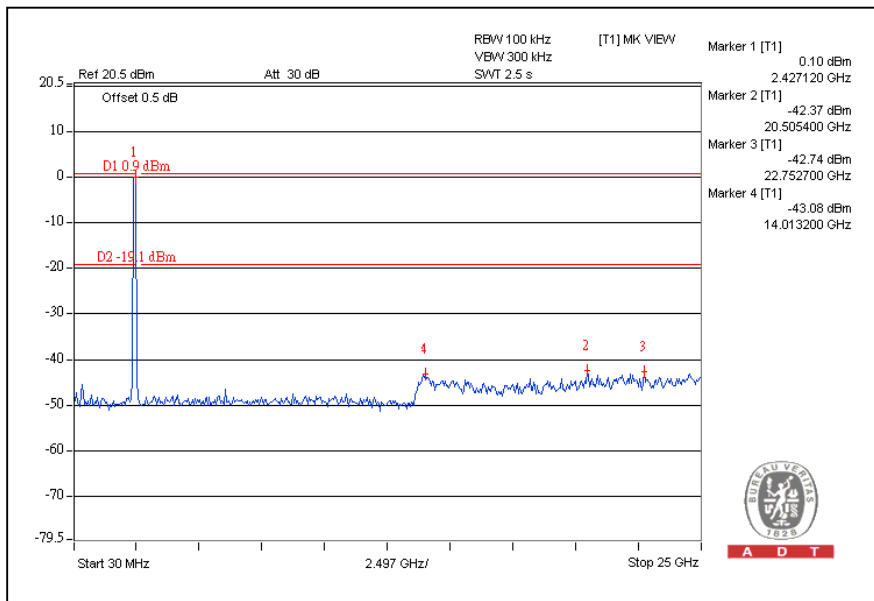

CH7

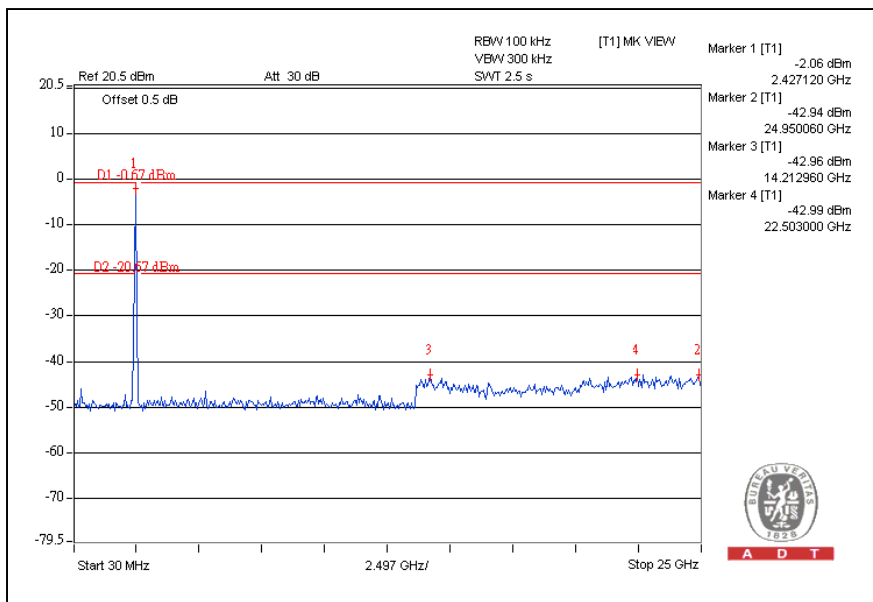



5. INFORMATION ON THE TESTING LABORATORIES

We, Bureau Veritas Consumer Products Services (H.K.) Ltd., Taoyuan Branch, were founded in 1988 to provide our best service in EMC, Radio, Telecom and Safety consultation. Our laboratories are accredited and approved according to ISO/IEC 17025:

Copies of accreditation certificates of our laboratories obtained from approval agencies can be downloaded from our web site: www.adt.com.tw/index.5/phtml.

If you have any comments, please feel free to contact us at the following:

Linko EMC/RF Lab:

Tel: 886-2-26052180

Fax: 886-2-26052943

Hsin Chu EMC/RF Lab:

Tel: 886-3-5935343

Fax: 886-3-5935342

Hwa Ya EMC/RF/Safety/Telecom Lab:

Tel: 886-3-3183232

Fax: 886-3-3185050

Email: service@adt.com.tw

Web Site: www.adt.com.tw

The address and road map of all our labs can be found in our web site also.



A D T

6.APPENDIX A - MODIFICATIONS RECORDERS FOR ENGINEERING CHANGES TO THE EUT BY THE LAB

No any modifications are made to the EUT by the lab during the test.

--- END ---