

Test Report

Report Number:

F162097E1

Equipment under Test (EUT):

**Dashboard with Bluetooth and WLAN for Motorbikes
ICC6.5in**

Applicant:

Robert Bosch Car Multimedia GmbH

Manufacturer:

Robert Bosch Car Multimedia GmbH



Deutsche
Akkreditierungsstelle
D-PL-17186-01-01
D-PL-17186-01-02
D-PL-17186-01-03

References

- [1] **ANSI C63.10-2013**, American National Standard of Procedures for Compliance Testing of Unlicensed Wireless Devices
- [2] **FCC CFR 47 Part 15 (July 2017)**, Radio Frequency Devices
- [2] **RSS-247 Issue 2 (February 2017)**, Digital Transmission Systems (DTSs), Frequency Hopping Systems (FHSs) and Licence-Exempt Local Area Network (LE-LAN) Devices
- [2] **RSS-Gen Issue 4 (November 2014)**, General Requirements for Compliance of Radio Apparatus

Test Result

The requirements of the tests performed as shown in the overview (clause 4) were fulfilled by the equipment under test. The complete test results are presented in the following.

tested and written by:	Paul NEUFELD Name	 Signature	21.08.2017 Date
Authorized reviewer:	Holger BENTJE Name	 Signature	21.08.2017 Date

This test report is only valid in its original form.

Any reproduction of its contents in extracts without written permission of the accredited test laboratory PHOENIX TESTLAB GmbH is prohibited.

The test results herein refer only to the tested sample. PHOENIX TESTLAB GmbH is not responsible for any generalisations or conclusions drawn from these test results concerning further samples. Any modification of the tested samples is prohibited and leads to the invalidity of this test report. Each page necessarily contains the PHOENIX TESTLAB Logo and the TEST REPORT NUMBER.

Contents:		Page
1	Identification.....	4
1.1	Applicant.....	4
1.2	Manufacturer.....	4
1.3	Test Laboratory.....	4
1.4	EUT (Equipment Under Test).....	5
1.5	Technical Data of Equipment.....	7
1.6	Dates.....	7
2	Operational States.....	8
3	Additional Information.....	10
4	Overview.....	10
5	Results.....	11
5.1	Duty cycle.....	11
5.2	Maximum peak conducted output power.....	15
5.3	DTS Bandwidth.....	18
5.4	Peak Power Spectral Density.....	25
5.5	Band-edge compliance.....	29
5.6	Maximum unwanted emissions.....	43
6	Test Equipment.....	92
7	Report History.....	93
8	List of Annexes.....	93

1 Identification

1.1 Applicant

Name:	Robert Bosch Car Multimedia GmbH
Address:	Daimlerstraße 6 71229 Leonberg
Country:	Germany
Name for contact purposes:	Steven Watterott
Phone:	+49 711 811-14094
Fax:	+49 711 811-5194660
eMail Address:	Steven.Watterott@de.bosch.com
Applicant represented during the test by the following person:	none

1.2 Manufacturer

Name:	Robert Bosch Car Multimedia GmbH
Address:	Daimlerstraße 6 71229 Leonberg
Country:	Germany
Name for contact purposes:	Steven Watterott
Phone:	+49 711 811-14094
Fax:	+49 711 811-5194660
eMail Address:	Steven.Watterott@de.bosch.com
Applicant represented during the test by the following person:	none

1.3 Test Laboratory

The tests were carried out by: **PHOENIX TESTLAB GmbH**
Königswinkel 10
32825 Blomberg
Germany

Accredited by *Deutsche Akkreditierungsstelle GmbH* in compliance with
DIN EN ISO/IEC 17025 under Reg. No. < **D-PL-17186-01-02** >.

1.4 EUT (Equipment Under Test)

Test object: *	Motorcycle Headunit
Model / PMN: *	ICC6.5in
WLAN/BT module name: *	UGKZ7A1001A
WLAN/BT module manufacturer: *	ALPS ELECTRIC CO., LTD.
BT module name: *	UGXZEX304A
BT module manufacturer: *	ALPS ELECTRIC CO., LTD.
FCC ID: *	YBN-ICC6P5IN1
IC-Number: *	9595A-ICC6P5IN1
HVIN:*	ICC6.5in
HMN:*	N/A
Order number:*	-
Serial number: *	Radiated measurements: Engineering sample (marked #005) ^{*3} Antenna port conducted measurements: Engineering sample (marked #030) ^{*3}
PCB identifier: *	7283G10-L10
Hardware version / FVIN: *	11
Software version: *	001_011_044

* Declared by the applicant

^{*2} The manufacturer does not provide a hardware-version, but instead updates the order number of the WLAN module. Therefore the order number is submitted here.

^{*3} Differences between the two samples:

#005 Golden springs for ground connection Main-PCB to the housing
#030 Metal springs for ground connection Main-PCB to the housing; temporary antenna connectors

Frequency List WLAN (WLAN/BT module)

Channel 01	RX:	2412 MHz	TX:	2412 MHz
Channel 02	RX:	2417 MHz	TX:	2417 MHz
Channel 03	RX:	2422 MHz	TX:	2422 MHz
Channel 04	RX:	2427 MHz	TX:	2427 MHz
Channel 05	RX:	2432 MHz	TX:	2432 MHz
Channel 06	RX:	2437 MHz	TX:	2437 MHz
Channel 07	RX:	2442 MHz	TX:	2442 MHz
Channel 08	RX:	2447 MHz	TX:	2447 MHz
Channel 09	RX:	2452 MHz	TX:	2452 MHz
Channel 10	RX:	2457 MHz	TX:	2457 MHz
Channel 11	RX:	2462 MHz	TX:	2462 MHz

Frequency List Bluetooth (WLAN/BT module) & Bluetooth module

Channel 00	RX:	2402 MHz	TX:	2402 MHz
Channel 39	RX:	2441 MHz	TX:	2441 MHz
Channel 78	RX:	2480 MHz	TX:	2480 MHz

Ancillary Equipment:

Control box: *	Ansteuerbox BMW 2Wheeler 0,5m CM-CI2/ETP Skrebtsov Nr. 3331
Throttle grip end: *	BMW Multicontroller handle bar
DC power supply cable:	2 m laboratory cables

*Provided by the applicant

1.5 Technical Data of Equipment

Fulfills WLAN specification: *	IEEE, 802.11b, 802.11g, 802.11n HT20					
Fulfills Bluetooth specification: *	2.1 + EDR					
Antenna type: *	PCB antenna (WLAN/BT module) PCB antenna (BT only module)					
Antenna name: *	ANT016008LCS2442MA1 (WLAN/BT module) ANT016008LCS2442MA1 (BT only module)					
Antenna gain: *	-0.39dBi (WLAN/BT module) -0.12dBi (BT only module)					
Antenna connector: *	None					
Power supply:	DC					
Supply voltage Host:	U _{nom} =	13.0 V DC	U _{min} =	9.0 V DC	U _{max} =	18.0 V DC
Power supply:	DC					
Supply voltage WLAN/BT and BT module:	U _{nom} =	3.3 V DC	U _{min} =	3.25 V DC	U _{max} =	3.36 V DC
Type of modulation (WLAN): *	802.11b: DSSS 802.11g: OFDM 802.11n: OFDM					
Type of modulation (Bluetooth): *	1 Mbps: GFSK 2 Mbps: π/4-DQPSK 3 Mbps: 8DPSK					
Operating frequency range:*	2412 MHz to 2462 MHz (WLAN) 2402 MHz to 2480 MHz (Bluetooth)					
Number of channels: *	11 (WLAN) 79 (Bluetooth)					
Temperature range: *	-20 °C to +85 °C (radio modules shutdown at ~ 60°C)					
Lowest / highest internal clock frequency: *	32.768 kHz / 2480 MHz					

1.6 Dates

Date of receipt of test sample:	24.04.2017
Start of test:	27.04.2017
End of test:	30.06.2017

2 Operational States

The EUT is motorcycle dashboard with Bluetooth and WLAN capability. One radio module connects the dashboard to a smartphone via WLAN and Bluetooth. The other radio module connects the dashboard to a helmet microphone and loudspeaker combination.

The test modes were set by using the throttle grip end to navigate through the user interface of the EUT, which was modified so that the needed test modes could be activated.

The following operation modes were identified as worst case condition and used during the tests:

UGKZ7A1001A (BT/WLAN combi module) with WLAN mode active

Operation mode	Description of the operation mode	Module	channel	mode	Data rate / Mbps
1	Continuous transmitting on 2412 MHz	UGKZ7A1001A	1	802.11b	1 Mbps
2	Continuous transmitting on 2437 MHz	UGKZ7A1001A	6	802.11b	1 Mbps
3	Continuous transmitting on 2462 MHz	UGKZ7A1001A	11	802.11b	1 Mbps
4	Continuous transmitting on 2412 MHz	UGKZ7A1001A	1	802.11g	6 Mbps
5	Continuous transmitting on 2437 MHz	UGKZ7A1001A	6	802.11g	6 Mbps
6	Continuous transmitting on 2462 MHz	UGKZ7A1001A	11	802.11g	6 Mbps
7	Continuous transmitting on 2412 MHz	UGKZ7A1001A	1	802.11n20	6.5 Mbps
8	Continuous transmitting on 2437 MHz	UGKZ7A1001A	6	802.11n20	6.5 Mbps
9	Continuous transmitting on 2462 MHz	UGKZ7A1001A	11	802.11n20	6.5 Mbps

UGKZ7A1001A (BT/WLAN combi module) with Bluetooth mode active

Operation mode	Description of the operation mode	Module	channel	mode	Data rate / Mbps
10	Continuous transmitting on 2402 MHz	UGKZ7A1001A	0	DH5	1 Mbps
11	Continuous transmitting on 2441 MHz	UGKZ7A1001A	39	DH5	1 Mbps
12	Continuous transmitting on 2480 MHz	UGKZ7A1001A	78	DH5	1 Mbps
13	Continuous transmitting on 2402 MHz	UGKZ7A1001A	0	2DH5	2 Mbps
14	Continuous transmitting on 2441 MHz	UGKZ7A1001A	39	2DH5	2 Mbps
15	Continuous transmitting on 2480 MHz	UGKZ7A1001A	78	2DH5	2 Mbps
16	Continuous transmitting on 2402 MHz	UGKZ7A1001A	0	3DH5	3 Mbps
17	Continuous transmitting on 2441 MHz	UGKZ7A1001A	39	3DH5	3 Mbps
18	Continuous transmitting on 2480 MHz	UGKZ7A1001A	78	3DH5	3 Mbps

UGXZEX304A (BT only module)

Operation mode	Description of the operation mode	Module	channel	mode	Data rate / Mbps
19	Continuous transmitting on 2402 MHz	UGXZEX304A	0	DH5	1 Mbps
20	Continuous transmitting on 2441 MHz	UGXZEX304A	39	DH5	1 Mbps
21	Continuous transmitting on 2480 MHz	UGXZEX304A	78	DH5	1 Mbps
22	Continuous transmitting on 2402 MHz	UGXZEX304A	0	2DH5	2 Mbps
23	Continuous transmitting on 2441 MHz	UGXZEX304A	39	2DH5	2 Mbps
24	Continuous transmitting on 2480 MHz	UGXZEX304A	78	2DH5	2 Mbps
25	Continuous transmitting on 2402 MHz	UGXZEX304A	0	3DH5	3 Mbps
26	Continuous transmitting on 2441 MHz	UGXZEX304A	39	3DH5	3 Mbps
27	Continuous transmitting on 2480 MHz	UGXZEX304A	78	3DH5	3 Mbps

Simultaneous transmission (UGKZ7A1001A & UGXZEX304A active simultaneous)

Operation mode	Description of the operation mode	Module	channel	mode	Data rate / Mbps
28	Simultaneous transmission, WLAN (UGKZ7A1001A) on channel 1 and BT (UGXZEX304A) on channel 78	UGKZ7A1001A & UGXZEX304A	1 & 78	802.11b & DH5	1 Mbps & 1 Mbps
29	Simultaneous transmission, BT (UGKZ7A1001A) on channel 0 and BT (UGXZEX304A) on channel 78	UGKZ7A1001A & UGXZEX304A	0 & 78	DH5 & DH5	1 Mbps & 1 Mbps

Power Settings for all measurements:

Module	Technology	mode	Power Setting (all channels)
UGKZ7A1001A	WLAN	802.11b	14.0
UGKZ7A1001A	WLAN	802.11g/n20	11.0
UGKZ7A1001A	Bluetooth	All modes	0.0

Module	Technology	mode	Power Setting (all channels)
UGXZEX304A	Bluetooth	All modes	0.0

3 Additional Information

All tests were performed with unmodified samples.

Modules on the EUT:

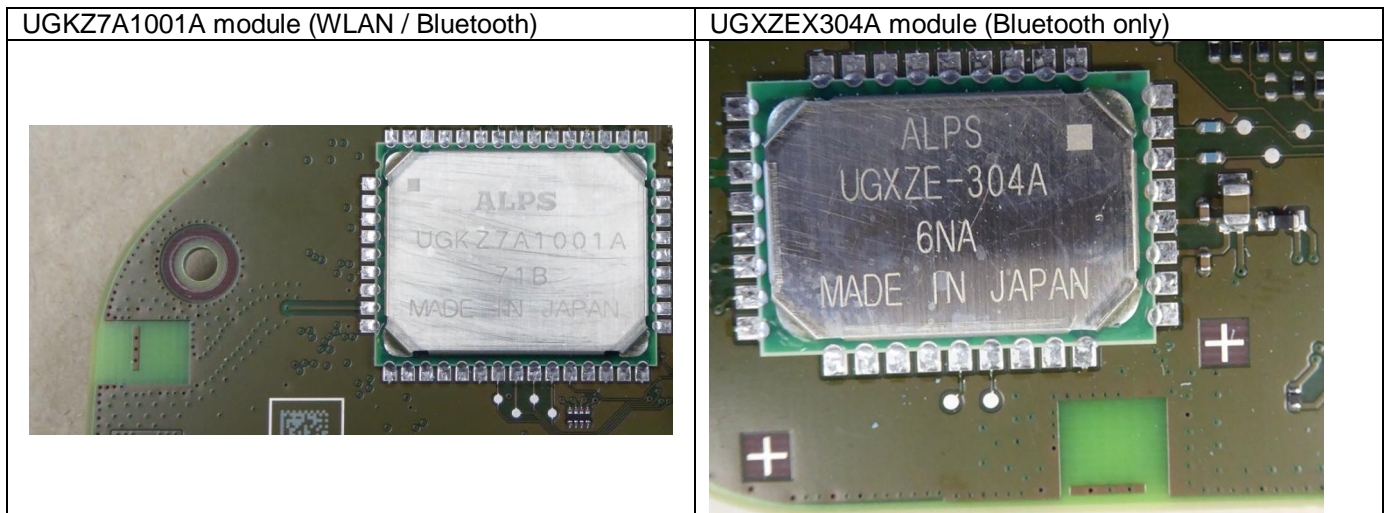

4 Overview

Application	Frequency range [MHz]	FCC 47 CFR Part 15 section [2]	RSS-247 [3] or RSS-Gen, Issue 4 [4]	Status	Refer page
Maximum Peak Output Power	2400.0 - 2483.5	15.247 (b) (3), (4)	5.4 (2) [3]	Passed	15 et seq
DTS Bandwidth	2400.0 - 2483.5	15.247 (a) (2)	5.2 (1) [3]	Passed	18 et seq
Peak Power Spectral Density	2400.0 - 2483.5	15.247 (e)	5.2 (2) [3]	Passed	25 et seq
Band edge compliance	2400.0 - 2483.5	15.247 (d)	5.5 [3] 8.9 [4], 8.10 [4]	Passed	29 et seq.
Radiated emissions (transmitter)	0.009 – 26,500	15.247 (d) 15.205 (a) 15.209 (a)	5.5 [3] 8.9 [4], 8.10 [4]	Passed	43 et seq.
Conducted emissions on supply line	0.15 - 30	15.207 (a)	8.8 [4]	Not applicable*	-

* Not applicable because the EUT is intended to be used in a vehicular environment

5 Results

5.1 Duty cycle

5.1.1 Method of measurement

The measurement was performed as an antenna port conducted measurement, as shown below.

Test Setup:

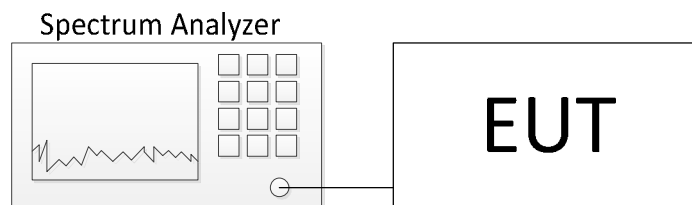

The method described in chapter 11.6.0 b) of document [1] was used to perform the following test.

The measurements was only performed for Bluetooth, since the WLAN test mode was transmitting continuously without off periods.

The duty cycle was equal for all Bluetooth modulations, therefore only one exemplary result is submitted below.

The following measurement technique was used:

The zero-span mode on a spectrum analyzer or EMI receiver if the response time and spacing between two bins on the sweep are sufficient to permit accurate measurements of the on and off times of the transmitted signal.

- Set the center frequency of the instrument to the center frequency of the transmission.
- Set $RBW \geq OBW$ if possible; otherwise, set RBW to the largest available value.
- Set $VBW \geq RBW$.
- Set detector = peak or average.
- The zero-span measurement method shall not be used unless both RBW and VBW are $> 50/T$ and the number of sweep points across duration T exceeds 100. (For example, if VBW and/or RBW are limited to 3 MHz, then the zero-span method of measuring duty cycle shall not be used if $T \leq 16.7$ microseconds.)

5.1.2 Test results

Ambient temperature	22 °C
---------------------	-------

Relative humidity	40 %
-------------------	------

The EUT was measured conducted at the antenna ports with the aid of a spectrum analyzer.

UGKZ7A1001A (BT/WLAN combi module) with WLAN mode active

The transmission in test mode was continuous without any gaps. Therefore no duty cycle correction was needed for the WLAN measurements

UGXZEX304A (BT only module)

162097 DutyCycle BT DH5 BT1.wmf: Duty cycle measurement on channel 0 in DH5 mode, BT Helmet

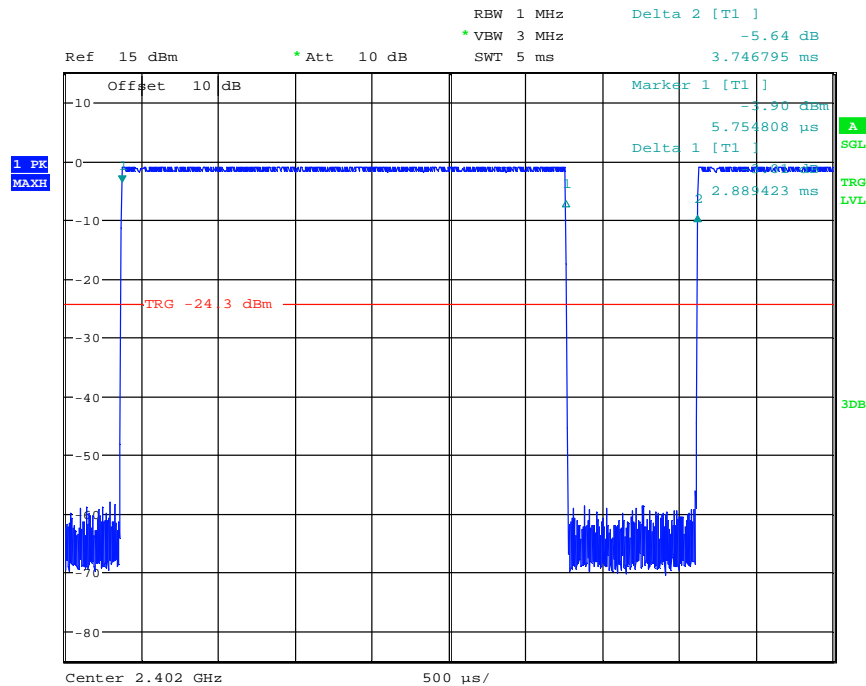

$$T_{TX_On} = 2.889ms, T_{TX_Period} = 3.748ms \quad (4)$$

$$\frac{50}{T_{TX_On}} = \frac{50}{2.889ms} = 17.307kHz \quad \text{£ RBW £ VBW} \quad (5)$$

Measurement Points 10000 for 5 ms ÷ 2.889 ms = 737 measurement points ÷ Signal has 5778 measurement points (and fulfils the requirement of at least 100 Points resolution for the signal)

If power averaging (RMS) mode was used in step f), then the applicable correction factor is $10 \log(1/x)$, where x is the duty cycle.

$$x = \frac{T_{TX_On}}{T_{TX_Period}} = \frac{2.889ms}{3.748ms} = 0.771 = 77.1\% \quad (6)$$

$$\text{Correction factor: } 10 \times \log_{10} \frac{1}{0.771} = 1.1dB \quad (7)$$

For average measurements a correction factor of 1.1 dB is used for all tests with the Bluetooth only module.

TEST EQUIPMENT USED FOR THE TEST:

30

5.2 Maximum peak conducted output power

5.2.1 Method of measurement

The EUT was measured conducted at the antenna ports with the aid of a peak power meter.

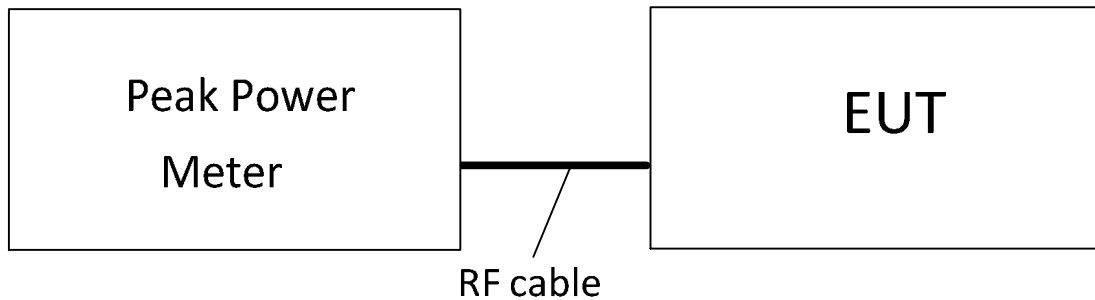

Acceptable measurement configurations

Procedure 11.9.1.3 in [1] was used for the following test.

The maximum peak conducted output power may be measured using a broadband peak RF power meter. The power meter shall have a video bandwidth that is greater than or equal to the DTS bandwidth and shall use a fast-responding diode detector.

The measurement was performed at the upper and lower end and the middle of the assigned frequency band.

5.2.2 Test results

Ambient temperature	22 °C	Relative humidity	62 %
---------------------	-------	-------------------	------

All antenna gains are below 6 dBi, therefore no conducted output limit reduction is necessary.

For the test, a sample with temporary antenna connector was used, which was provided by the applicant.

UGKZ7A1001A (BT/WLAN combi module) with WLAN mode active:

Operation mode	Frequency [MHz]	Conducted output power [dBm]	Limit [dBm]
1	2412	12.2	30
2	2437	12.4	30
3	2462	12.7	30
4	2412	16.2	30
5	2437	16.7	30
6	2462	16.6	30
7	2412	16.0	30
8	2437	16.6	30
9	2462	16.5	30

UGKZ7A1001A (BT/WLAN combi module) with Bluetooth mode active

Operation mode	Frequency [MHz]	Conducted output [dBm]	Limit [dBm]
10	2402	-4.8	30
11	2441	-4.3	30
12	2480	-4.0	30
13	2402	-3.3	30
14	2441	-2.6	30
15	2480	-2.1	30
16	2402	-3.0	30
17	2441	-2.4	30
18	2480	-1.9	30

UGXZEX304A (BT only module):

Operation mode	Frequency [MHz]	Conducted output power [dBm]	Limit [dBm]
19	2402	-0.6	30
20	2441	1.3	30
21	2480	1.1	30
22	2402	-1.7	30
23	2441	0.3	30
24	2480	0.1	30
25	2402	-1.5	30
26	2441	0.4	30
27	2480	0.3	30

Test: Passed

TEST EQUIPMENT USED FOR THE TEST:

60, 61

5.3 DTS Bandwidth

5.3.1 Method of measurement

The EUT was tested with a spectrum analyzer connected directly to the EUT.



The measurement procedure refers to part 11.8.1 of document [1].

- Set RBW = 100 kHz.
- Set the video bandwidth (VBW) $\geq 3 \times$ RBW.
- Detector = Peak.
- Trace mode = max hold.
- Sweep = auto couple.
- Allow the trace to stabilize.
- Measure the maximum width of the emission that is constrained by the frequencies associated with the two outermost amplitude points (upper and lower frequencies) that are attenuated by 6 dB relative to the maximum level measured in the fundamental emission.

5.3.2 Test result

Ambient temperature	22 °C	Relative humidity	59 %
---------------------	-------	-------------------	------

The following results were measured at the antenna port of the EUT. The plots show an exemplary measurement result for the worst documented case. The other results are listed in the following tables.

For the test, a sample with temporary antenna connector was used, which was provided by the applicant.

UGKZ7A1001A (BT/WLAN combi module) with WLAN mode active:

162097_6dB-BW_b_1.wmf: 6-dB Bandwidth (operation mode 1):

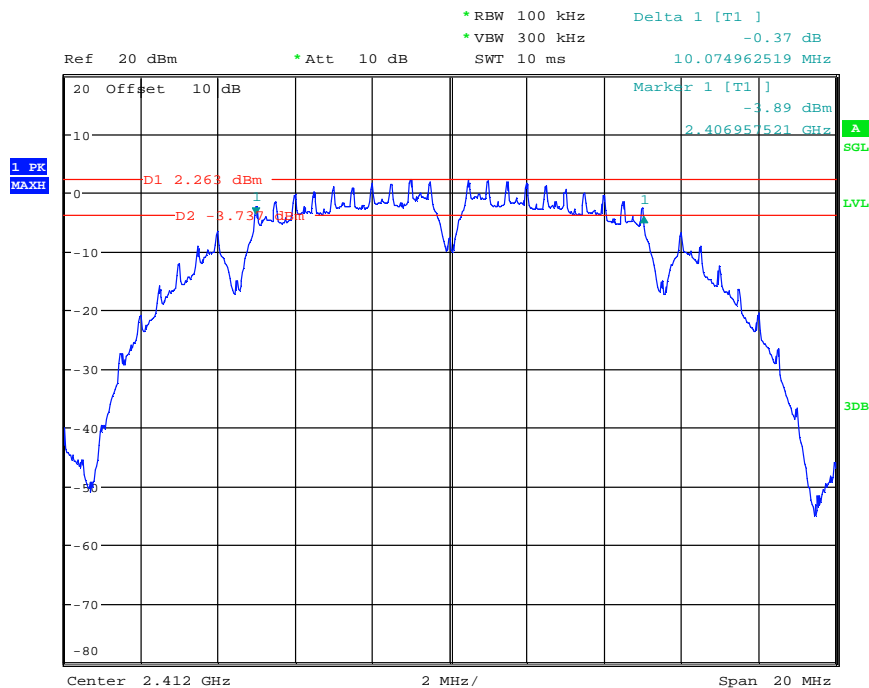

162097_99%BW_n20_6.wmf: 99% Bandwidth (operation mode 8):

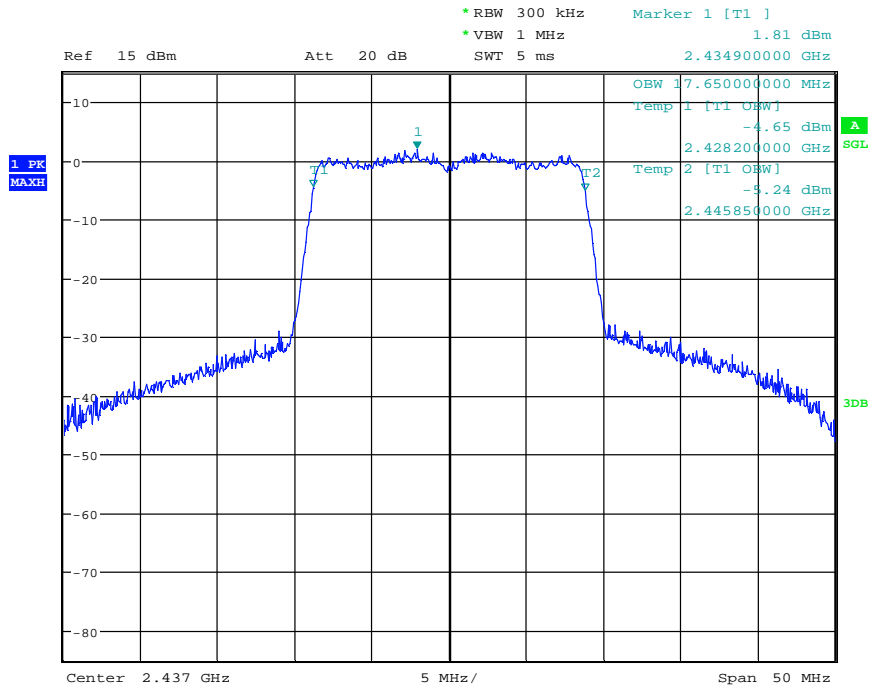

Operation Mode	Center Frequency [MHz]	Minimum 6-dB Bandwidth Limit [MHz]	6 dB Bandwidth [MHz]	99 % Bandwidth [MHz]	Result
1	2412	0.5	10.075	13.140	Passed
2	2437	0.5	10.095	13.110	Passed
3	2462	0.5	10.105	13.080	Passed
4	2412	0.5	16.372	16.750	Passed
5	2437	0.5	16.387	16.750	Passed
6	2462	0.5	16.387	16.750	Passed
7	2412	0.5	17.376	17.600	Passed
8	2437	0.5	17.331	17.650	Passed
9	2462	0.5	17.571	17.650	Passed

UGKZ7A1001A (BT/WLAN combi module) with Bluetooth mode active

162097 6dB-BW BT_DH5_BT39.wmf: 6-dB Bandwidth (operation mode 11):

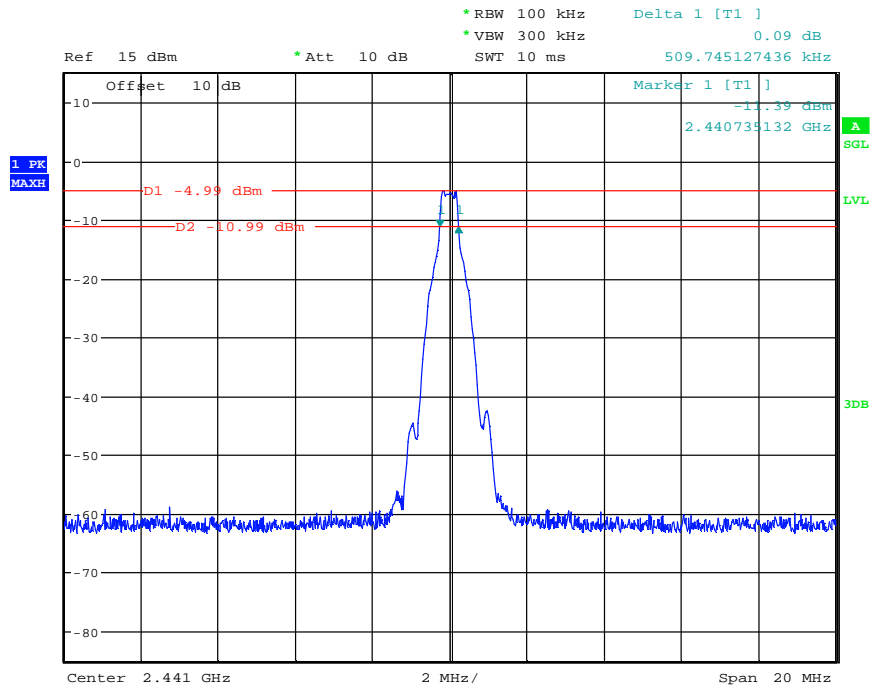

162097 BT-Smart 99%BW_BT_2DH5_BT79.wmf: 99% Bandwidth (operation mode 15):

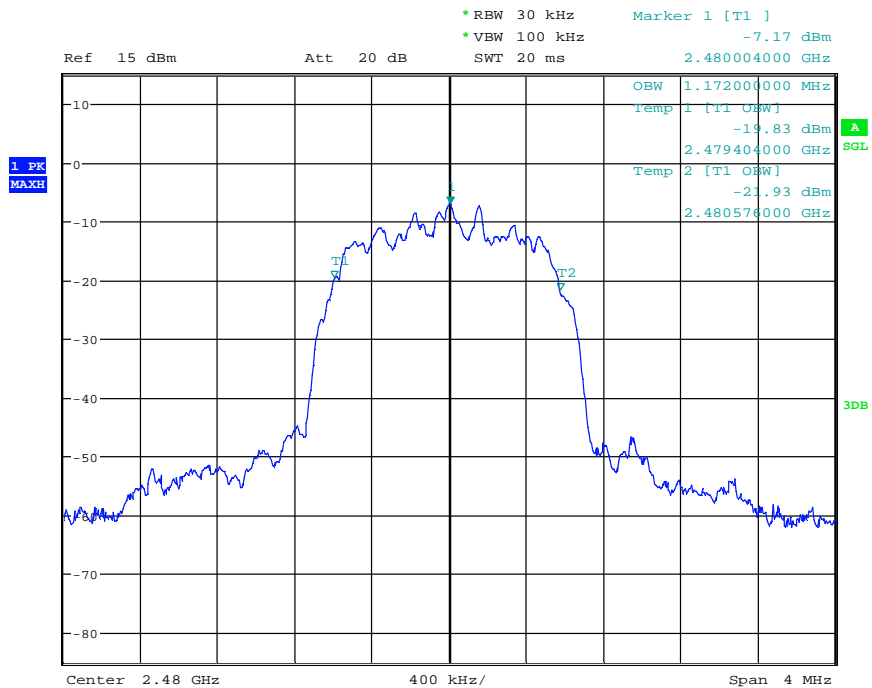

Operation Mode	Center Frequency [MHz]	Minimum 6-dB Bandwidth Limit [MHz]	6 dB Bandwidth [MHz]	99 % Bandwidth [MHz]	Result
10	2402	0.5	0.520	0.868	Passed
11	2441	0.5	0.510	0.868	Passed
12	2480	0.5	0.510	0.860	Passed
13	2402	0.5	1.059	1.168	Passed
14	2441	0.5	1.062	1.168	Passed
15	2480	0.5	1.054	1.172	Passed
16	2402	0.5	1.054	1.172	Passed
17	2441	0.5	1.052	1.172	Passed
18	2480	0.5	1.052	1.172	Passed

UGXZEX304A (BT only module)

162097 6dB-BW BT DH5 BT39.wmf: 6-dB Bandwidth (operation mode 20):

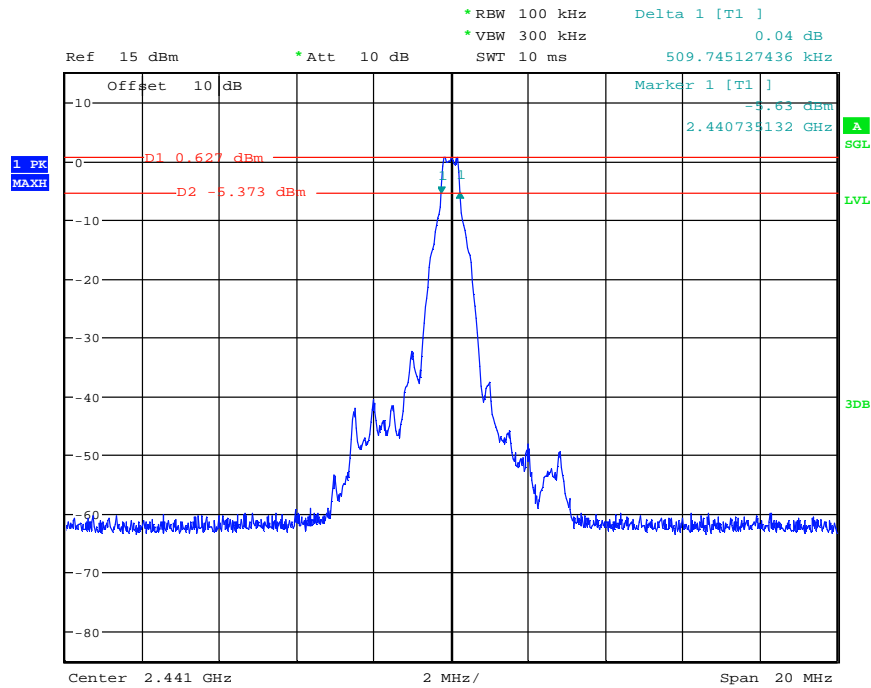

162097 BT-Helm_99%BW_BT_2DH5_BT39.wmf: 99% Bandwidth (operation mode 23):

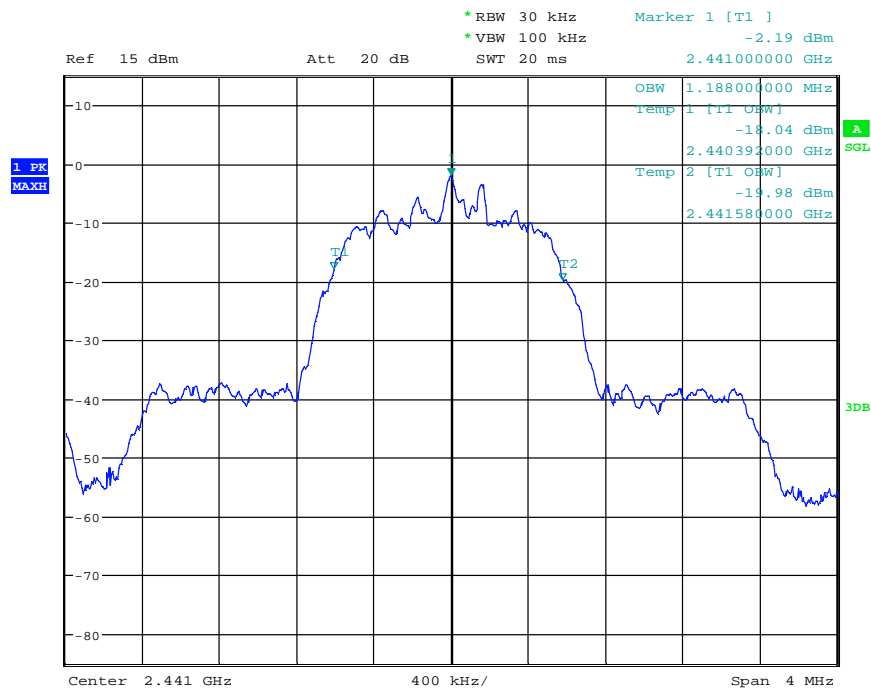

Operation Mode	Center Frequency [MHz]	Minimum 6-dB Bandwidth Limit [MHz]	6 dB Bandwidth [MHz]	99 % Bandwidth [MHz]	Result
19	2402	0.5	0.520	0.876	Passed
20	2441	0.5	0.510	0.868	Passed
21	2480	0.5	0.510	0.868	Passed
22	2402	0.5	0.970	1.184	Passed
23	2441	0.5	0.972	1.188	Passed
24	2480	0.5	0.967	1.188	Passed
25	2402	0.5	1.000	1.180	Passed
26	2441	0.5	0.997	1.184	Passed
27	2480	0.5	0.990	1.184	Passed

Test: Passed

TEST EQUIPMENT USED FOR THE TEST:

30

5.4 Peak Power Spectral Density

5.4.1 Method of measurement

The EUT was tested with a spectrum analyzer connected directly to the EUT.

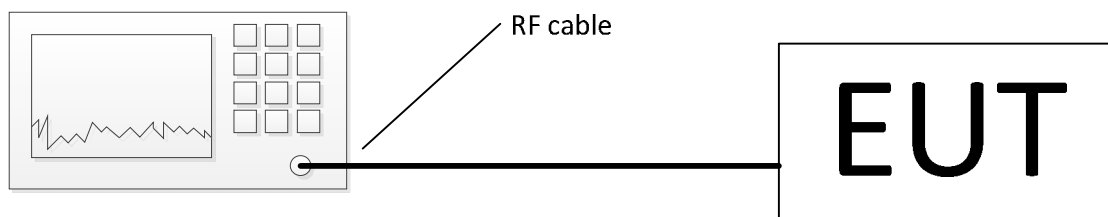

The measurement procedure refers to part 10.10.2 of document [1].

- Set analyser center frequency to DTS channel center frequency
- Set the span to 1.5 times the DTS bandwidth.
- Set the RBW to: $3 \text{ kHz} \leq \text{RBW} \leq 100 \text{ kHz}$.
- Set the VBW $\geq 3 \times \text{RBW}$.
- Detector = peak.
- Sweep time = auto couple.
- Trace mode = max hold.
- Allow trace to fully stabilize.
- Use the peak marker function to determine the maximum amplitude level within the RBW.
- If measured value exceeds limit, reduce RBW (not less than 3 kHz) and repeat.

5.4.2 Test result

Ambient temperature	22 °C	Relative humidity	59 %
---------------------	-------	-------------------	------

The following results were measured at the antenna port of the EUT. The plots shows an exemplary measurement result for the worst documented case. The other results are listed in the following tables.

For the test, a sample with temporary antenna connector was used, which was provided by the applicant.

UGKZ7A1001A (BT/WLAN combi module) with WLAN mode active

WLAN1100_ant1_PwrSpecDens_b_6.wmf: Power Spectral Density (operation mode 1):

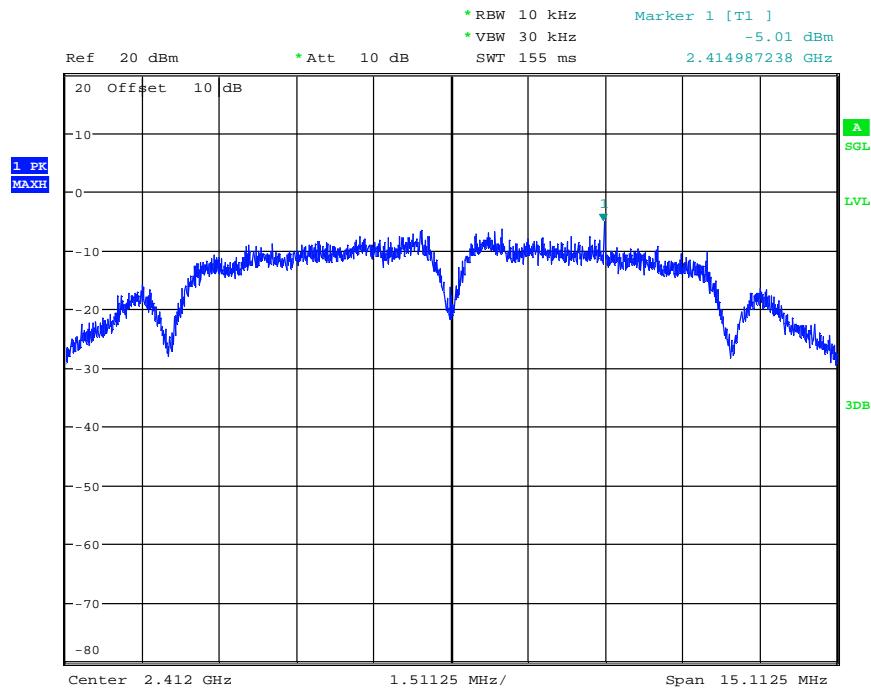

Operation Mode	Peak Frequency [MHz]	Power Spectral Density Limit [dBm/3kHz]	Power Spectral Density Reading [dBm / 10 kHz]	Result
1	2414.987	8	-5.0	Passed
2	2436.248	8	-6.4	Passed
3	2462.748	8	-6.6	Passed
4	2413.243	8	-11.6	Passed
5	2439.799	8	-10.8	Passed
6	2462.236	8	-10.9	Passed
7	2413.609	8	-10.9	Passed
8	2445.109	8	-10.7	Passed
9	2465.108	8	-10.3	Passed

UGKZ7A1001A (BT/WLAN combi module) with Bluetooth mode active

162097 PwrSpecDens BT_DH5_BT78.wmf: Power Spectral Density (operation mode 18):

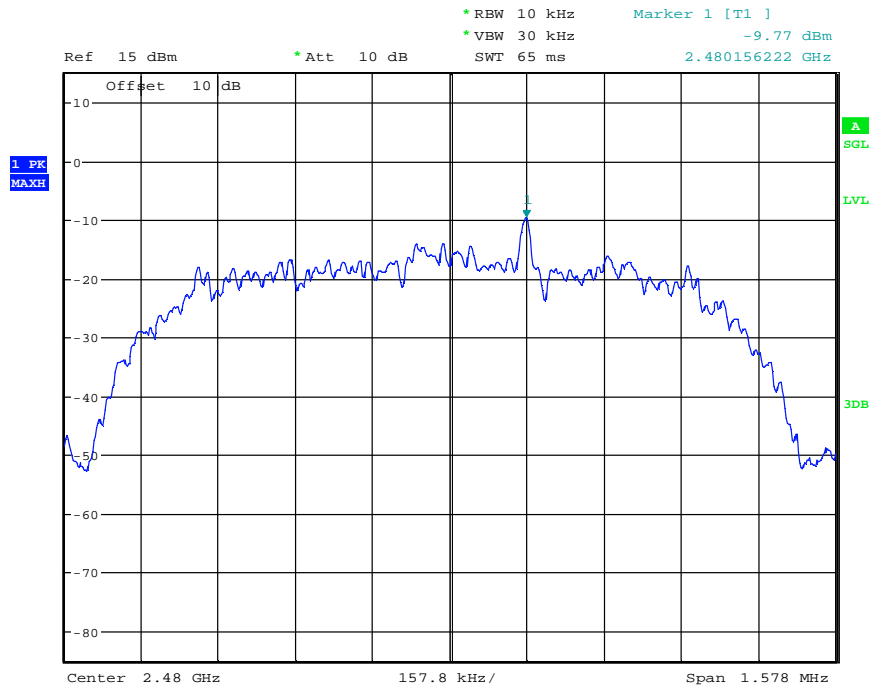

Operation Mode	Peak Frequency [MHz]	Power Spectral Density Limit [dBm/3kHz]	Power Spectral Density Reading [dBm / 10 kHz]	Result
10	2402.155	8	-11.1	Passed
11	2441.155	8	-10.6	Passed
12	2480.155	8	-10.3	Passed
13	2401.824	8	-14.1	Passed
14	2440.823	8	-13.6	Passed
15	2479.823	8	-13.2	Passed
16	2402.157	8	-10.6	Passed
17	2441.156	8	-10.1	Passed
18	2480.156	8	-9.8	Passed

UGXZEX304A (BT only module)

162097 PwrSpecDens BT_DH5_BT39.wmf: Power Spectral Density (operation mode 20):

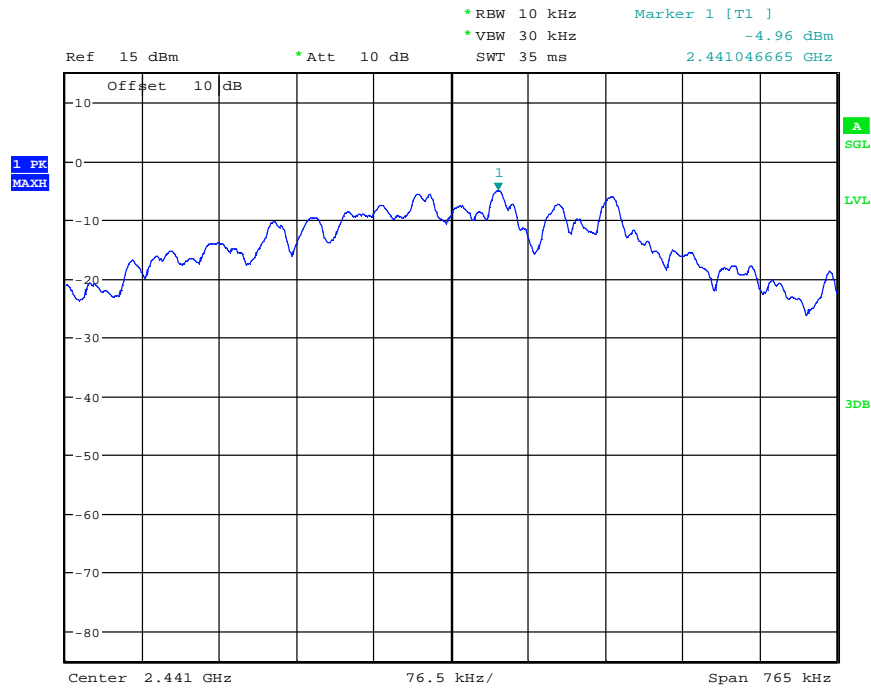

Operation Mode	Peak Frequency [MHz]	Power Spectral Density Limit [dBm/3kHz]	Power Spectral Density Reading [dBm / 10 kHz]	Result
19	2402.049	8	-6.8	Passed
20	2441.047	8	-5.0	Passed
21	2480.045	8	-5.1	Passed
22	2401.980	8	-9.3	Passed
23	2440.977	8	-7.4	Passed
24	2479.978	8	-7.7	Passed
25	2401.991	8	-8.7	Passed
26	2440.985	8	-7.1	Passed
27	2479.981	8	-7.4	Passed

Test: Passed

TEST EQUIPMENT USED FOR THE TEST:

30

5.5 Band-edge compliance

5.5.1 Method of measurement (band edges next to unrestricted bands (conducted))

The EUT was tested with a spectrum analyzer connected directly to the EUT.

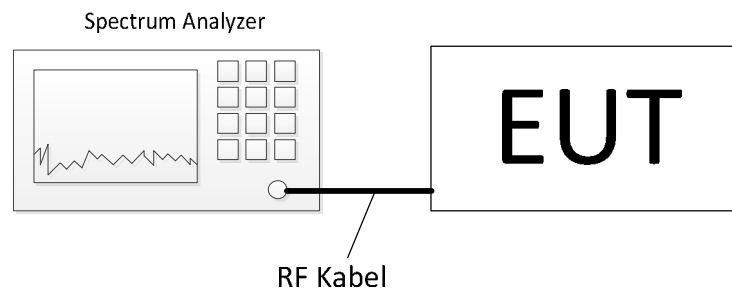

The relating measurements were carried out in a conducting manner. Therefore, the antenna connector was directly connected to a spectrum analyzer. The measurement procedure refers to part 11.11.2 and 11.11.3 of document [1].

Measurement Procedure Reference – Reference Level:

- RBW = 100 kHz.
- VBW \geq 300 kHz.
- Set the span to \geq 1.5 times the DTS Bandwidth.
- Detector = Peak.
- Sweep time = auto couple.
- Trace mode = max hold.
- Allow trace to fully stabilise.
- Use the peak marker function to determine the the maximum PSD level.

Measurement Procedure – Unwanted Emissions

- Set the center frequency and span to encompass the frequency range to be measured.
- RBW = 100 kHz.
- VBW \geq 300 kHz.
- Detector = Peak.
- Ensure that the number of measurement points \geq span/RBW.
- Sweep time = auto couple.
- Trace Mode = max hold.
- Allow the trace to stabilise.
- Use the peak marker function to determine the maximum amplitude level.

The measurement procedure at the band edges was simplified by performing the measurement in just one plot. Both, the in-band-emission and the unwanted emission were be encompassed by the span. After trace stabilization, the maximum peak was be determined by a peak detector and the value was marked by an appropriate limit line. The second limit line, which is 20 dB below the first, marks the limit for the emissions in the unrestricted band. A maximum-peak-detector marks the highest emission in the unrestricted band next to the band edge.

The measurements were performed at the lower end of the 2.4 GHz band.

5.5.2 Test result (band edges next to unrestricted bands (conducted))

Ambient temperature	22 °C
---------------------	-------

Relative humidity	59 %
-------------------	------

The following results were measured at the antenna port of the EUT. The plot shows an exemplary measurement result for the worst documented case. The other results are listed in the following table.

For the test, a sample with temporary antenna connector was used, which was provided by the applicant.

UGKZ7A1001A (BT/WLAN combi module) with WLAN mode active

162097 BandEdgeUnrestr_n20_1.wmf: conducted band-edge compliance (operation mode 7):

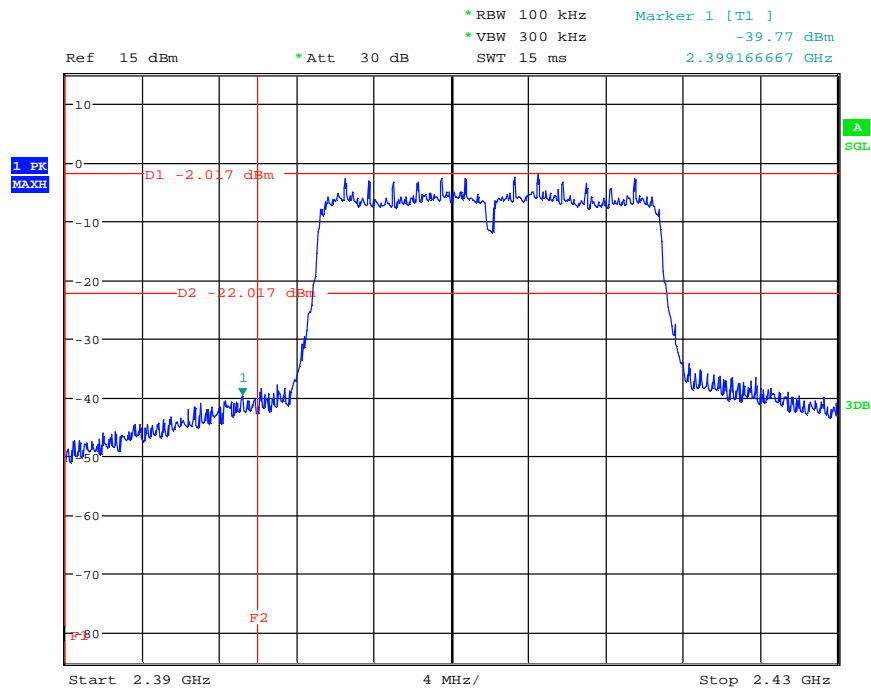

Operation mode	Emission Frequency [MHz]	Reference Level [dBm]	Limit [dBm]	Emission Level [dBm]	Margin [dB]	Result
1	2396.987	2.8	-17.2	-41.6	24.4	Passed
4	2398.846	-1.9	-21.9	-39.8	17.9	Passed
7	2399.167	-2.0	-22.0	-39.8	17.8	Passed

UGKZ7A1001A (BT/WLAN combi module) with Bluetooth mode active

162097 BT-Smart BandEdgeUnrestr BT 3DH5 BT1.wmf: conducted band-edge compliance (operation mode 16):

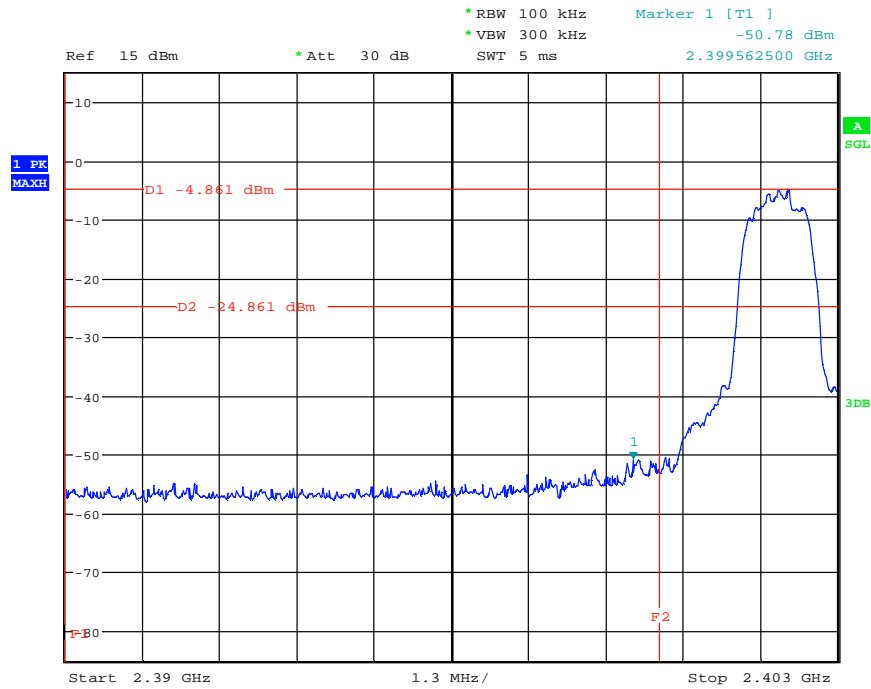

Operation mode	Emission Frequency [MHz]	Reference Level [dBm]	Limit [dBm]	Emission Level [dBm]	Margin [dB]	Result
10	2390.187	-5.0	-25.0	-53.9	28.9	Passed
13	2399.917	-5.0	-25.0	-52.3	27.3	Passed
16	2399.562	-4.9	-24.9	-50.8	25.9	Passed

UGKZ7A1001A (BT/WLAN combi module) with Bluetooth mode active

162097 BandEdgeUnrestr n20 1.wmf: conducted band-edge compliance (operation mode 13):

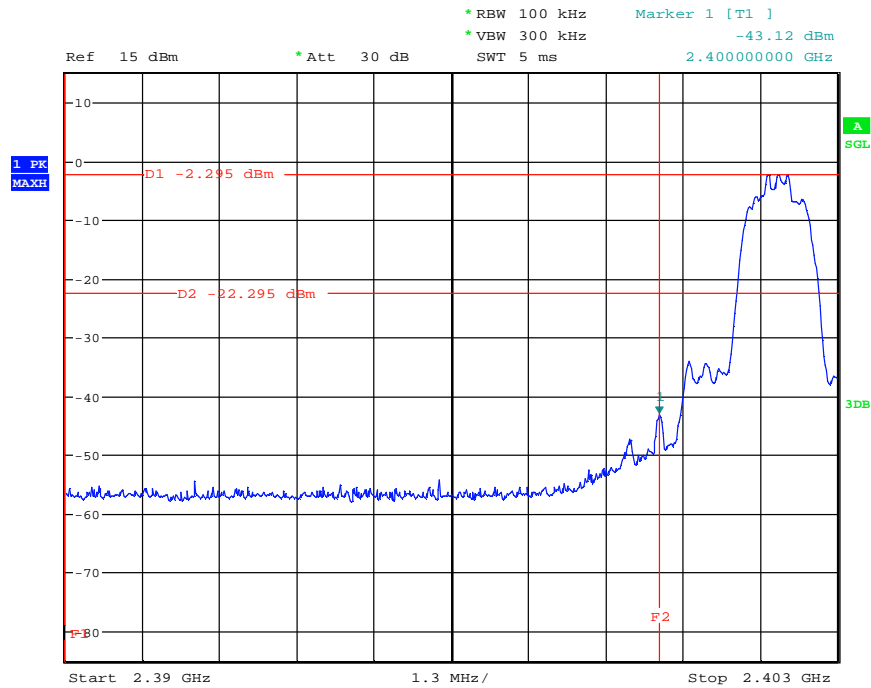

Operation mode	Emission Frequency [MHz]	Reference Level [dBm]	Limit [dBm]	Emission Level [dBm]	Margin [dB]	Result
19	2400.000	-0.8	-20.8	-50.3	29.5	Passed
22	2400.000	-2.4	-22.4	-43.5	21.1	Passed
25	2400.000	-2.3	-22.3	-43.1	20.8	Passed

Test: Passed

TEST EQUIPMENT USED FOR THE TEST:
30

5.5.3 Method of measurement (band edges next to restricted bands (conducted))

The same test set-up as used for the final conducted emission measurement shall be used (refer also subclause 5.6.1 of this test report).

After trace stabilisation the marker shall be set on the signal peak. The frequency line shall be set on the edge of the assigned frequency band. Now set the second marker on the emission at the band-edge, or on the highest modulation product outside of the band, if this level is higher than that at the band-edge. The level of the measured field strength shall be compared to the general limits specified in § 15.205.

The measurement was performed at the lower and the upper end of the 2.4 GHz band.

The calculation was performed with the following formula as described in chapter 11.12.2.2 e) in [1]:

$$E [\text{dBmV/m}] = EIRP [\text{dBm}] - 20\log(d) + 104.8 + G_{\text{Ant}} [\text{dBi}] + G_{\text{Array}} [\text{dB}] + Att_{\text{MeasCable}} [\text{dB}] + Att_{\text{RF-Switch}} [\text{dB}]$$

E [dBmV/m] = Field Strength [dBuV/m]

$EIRP$ [dBm] = Reading [dBm]

d = measurement distance in m

G_{Ant} [dBi] = Gain of the EUT antenna

G_{Array} [dB] = Array Gain [in case of multiple transmitting antenna port]

$Att_{\text{MeasCable}}$ [dB] = Attenuation of the measurement cables

$Att_{\text{RF-Switch}}$ [dB] = Attenuation of the RF Switch

5.5.4 Test result (band edges next to restricted bands (conducted))

Ambient temperature	22 °C	Relative humidity	59 %
---------------------	-------	-------------------	------

The plots show an exemplary measurement result for the worst documented case. The other results are listed in the following tables.

Since the antenna gain is below 0 dB, the antenna gain will be calculated as 0 dBi in the tables below.

UGKZ7A1001A (BT/WLAN combi module) with WLAN mode active

162097_BandEdgeRestr_n20_11.wmf: conducted band-edge compliance (operation mode 9):

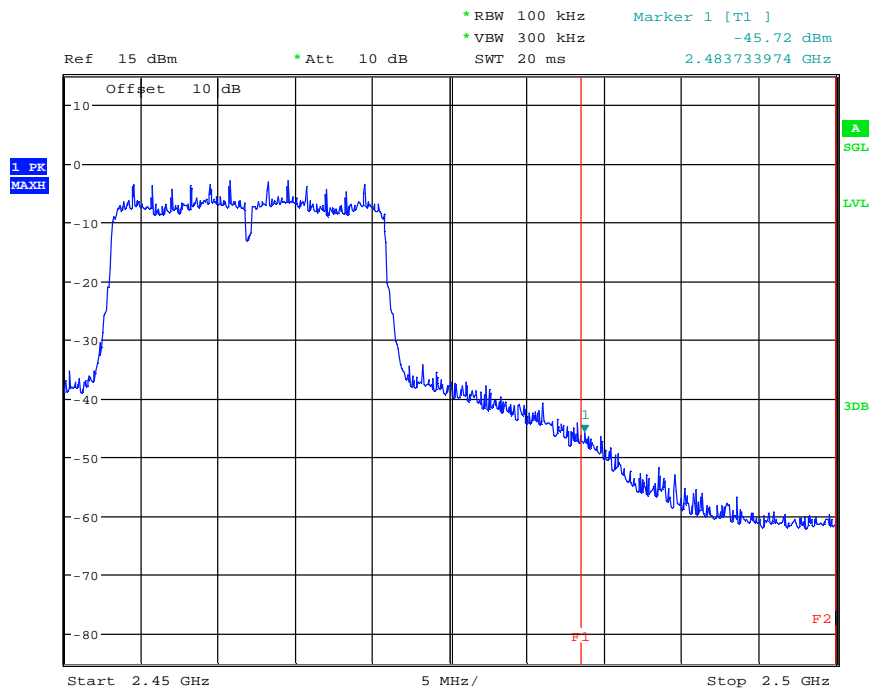

Band Edge Compliance, b-mode, channel 1, BT/WLAN module (Operation mode 1)							
Operation Mode	Frequency [MHz]	Field Strength [dBuV/m]	Peak Limit [dBuV/m]	Margin [dB]	Reading [dBm]	Antenna Gain + Array Gain [dBi]	Result
1	2377.791	46.5	74.0	27.5	-48.8	0.0	Passed
Operation Mode	Frequency [MHz]	Field Strength [dBuV/m]	Average Limit [dBuV/m]	Margin [dB]	Reading [dBm]	Antenna Gain + Array Gain [dBi]	Result
1	2376.406	36.2	54.0	17.8	-59.0	0.0	Passed
Measurement uncertainty				+0.66 dB / -0.72 dB			

Band Edge Compliance, b-mode, channel 11, BT/WLAN module (Operation mode 3)							
Operation Mode	Frequency [MHz]	Field Strength [dBuV/m]	Peak Limit [dBuV/m]	Margin [dB]	Reading [dBm]	Antenna Gain + Array Gain [dBi]	Result
3	2487.709	48.0	74.0	26.0	-47.3	0.0	Passed
Operation Mode	Frequency [MHz]	Field Strength [dBuV/m]	Average Limit [dBuV/m]	Margin [dB]	Reading [dBm]	Antenna Gain + Array Gain [dBi]	Result
3	2487.884	36.6	54.0	17.4	-58.7	0.0	Passed
Measurement uncertainty				+0.66 dB / -0.72 dB			

Band Edge Compliance, g-mode, channel 1, BT/WLAN module (Operation mode 4)							
Operation Mode	Frequency [MHz]	Field Strength [dBuV/m]	Peak Limit [dBuV/m]	Margin [dB]	Reading [dBm]	Antenna Gain + Array Gain [dBi]	Result
4	2388.373	63.7	74.0	10.3	-31.6	0.0	Passed
Operation Mode	Frequency [MHz]	Field Strength [dBuV/m]	Average Limit [dBuV/m]	Margin [dB]	Reading [dBm]	Antenna Gain + Array Gain [dBi]	Result
4	2389.998	43.9	54.0	10.1	-51.4	0.0	Passed
Measurement uncertainty				+0.66 dB / -0.72 dB			

Band Edge Compliance, g-mode, channel 11, BT/WLAN module (Operation mode 6)							
Operation Mode	Frequency [MHz]	Field Strength [dBuV/m]	Peak Limit [dBuV/m]	Margin [dB]	Reading [dBm]	Antenna Gain + Array Gain [dBi]	Result
6	2483.529	67.8	74.0	6.2	-27.4	0.0	Passed
Operation Mode	Frequency [MHz]	Field Strength [dBuV/m]	Average Limit [dBuV/m]	Margin [dB]	Reading [dBm]	Antenna Gain + Array Gain [dBi]	Result
6	2483.524	48.4	54.0	5.6	-46.9	0.0	Passed
Measurement uncertainty				+0.66 dB / -0.72 dB			

Band Edge Compliance, n20-mode, channel 1, BT/WLAN module (Operation mode 7)							
Operation Mode	Frequency [MHz]	Field Strength [dBuV/m]	Peak Limit [dBuV/m]	Margin [dB]	Reading [dBm]	Antenna Gain + Array Gain [dBi]	Result
7	2387.403	64.2	74.0	9.8	-31.1	0.0	Passed
Operation Mode	Frequency [MHz]	Field Strength [dBuV/m]	Average Limit [dBuV/m]	Margin [dB]	Reading [dBm]	Antenna Gain + Array Gain [dBi]	Result
7	2389.868	45.6	54.0	8.4	-49.7	0.0	Passed
Measurement uncertainty				+0.66 dB / -0.72 dB			

Band Edge Compliance, n20-mode, channel 11, BT/WLAN module (Operation mode 9)							
Operation Mode	Frequency [MHz]	Field Strength [dBuV/m]	Peak Limit [dBuV/m]	Margin [dB]	Reading [dBm]	Antenna Gain + Array Gain [dBi]	Result
9	2483.699	71.4	74.0	2.6	-23.9	0.0	Passed
Operation Mode	Frequency [MHz]	Field Strength [dBuV/m]	Average Limit [dBuV/m]	Margin [dB]	Reading [dBm]	Antenna Gain + Array Gain [dBi]	Result
9	2483.539	50.5	54.0	3.5	-44.8	0.0	Passed
Measurement uncertainty				+0.66 dB / -0.72 dB			

UGKZ7A1001A (BT/WLAN combi module) with Bluetooth mode active

162097 BandEdgeRestr BT DH5 BT78.wmf: conducted band-edge compliance (operation mode 18):

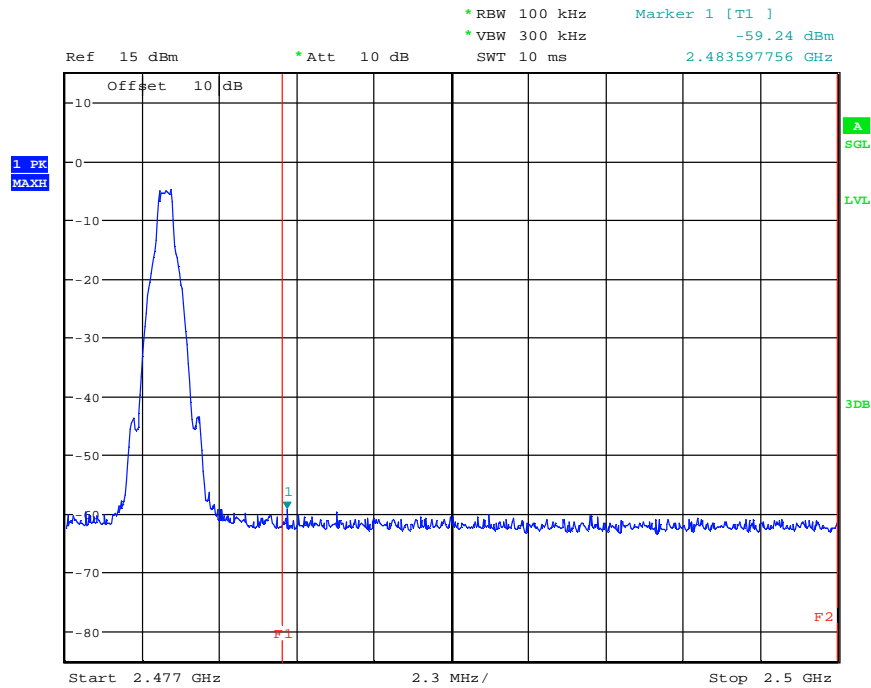

Band Edge Compliance, DH5-mode, channel 0, BT/WLAN module (Operation mode 10)							
Operation Mode	Frequency [MHz]	Field Strength [dBuV/m]	Peak Limit [dBuV/m]	Margin [dB]	Reading [dBm]	Antenna Gain + Array Gain [dBi]	Result
10	2380.942	41.7	74.0	32.3	-53.5	0.0	Passed
Operation Mode	Frequency [MHz]	Field Strength [dBuV/m]	Average Limit [dBuV/m]	Margin [dB]	Reading [dBm]	Antenna Gain + Array Gain [dBi]	Result
10	2380.902	31.9	54.0	22.1	-64.5	0.0	Passed
Measurement uncertainty				+0.66 dB / -0.72 dB			

Band Edge Compliance, DH5-mode, channel 78, BT/WLAN module (Operation mode 12)							
Operation Mode	Frequency [MHz]	Field Strength [dBuV/m]	Peak Limit [dBuV/m]	Margin [dB]	Reading [dBm]	Antenna Gain + Array Gain [dBi]	Result
12	2483.500	48.6	74.0	25.4	-46.7	0.0	Passed
Operation Mode	Frequency [MHz]	Field Strength [dBuV/m]	Average Limit [dBuV/m]	Margin [dB]	Reading [dBm]	Antenna Gain + Array Gain [dBi]	Result
12	2483.505	44.8	54.0	9.2	-51.7	0.0	Passed
Measurement uncertainty				+0.66 dB / -0.72 dB			

Band Edge Compliance, 2DH5-mode, channel 0, BT/WLAN module (Operation mode 13)							
Operation Mode	Frequency [MHz]	Field Strength [dBuV/m]	Peak Limit [dBuV/m]	Margin [dB]	Reading [dBm]	Antenna Gain + Array Gain [dBi]	Result
13	2383.942	41.7	74.0	32.3	-53.6	0.0	Passed
Operation Mode	Frequency [MHz]	Field Strength [dBuV/m]	Average Limit [dBuV/m]	Margin [dB]	Reading [dBm]	Antenna Gain + Array Gain [dBi]	Result
13	2386.347	31.7	54.0	22.3	-64.8	0.0	Passed
Measurement uncertainty				+0.66 dB / -0.72 dB			

Band Edge Compliance, 2DH5-mode, channel 78, BT/WLAN module (Operation mode 15)							
Operation Mode	Frequency [MHz]	Field Strength [dBuV/m]	Peak Limit [dBuV/m]	Margin [dB]	Reading [dBm]	Antenna Gain + Array Gain [dBi]	Result
15	2483.525	52.0	74.0	22.0	-43.3	0.0	Passed
Operation Mode	Frequency [MHz]	Field Strength [dBuV/m]	Average Limit [dBuV/m]	Margin [dB]	Reading [dBm]	Antenna Gain + Array Gain [dBi]	Result
15	2483.505	46.1	54.0	7.9	-50.3	0.0	Passed
Measurement uncertainty				+0.66 dB / -0.72 dB			

Band Edge Compliance, 3DH5-mode, channel 0, BT/WLAN module (Operation mode 16)							
Operation Mode	Frequency [MHz]	Field Strength [dBuV/m]	Peak Limit [dBuV/m]	Margin [dB]	Reading [dBm]	Antenna Gain + Array Gain [dBi]	Result
16	2379.354	41.3	74.0	32.7	-54.0	0.0	Passed
Operation Mode	Frequency [MHz]	Field Strength [dBuV/m]	Average Limit [dBuV/m]	Margin [dB]	Reading [dBm]	Antenna Gain + Array Gain [dBi]	Result
16	2382.934	31.5	54.0	22.5	-64.9	0.0	Passed
Measurement uncertainty				+0.66 dB / -0.72 dB			

Band Edge Compliance, 3DH5-mode, channel 78, BT/WLAN module (Operation mode 18)							
Operation Mode	Frequency [MHz]	Field Strength [dBuV/m]	Peak Limit [dBuV/m]	Margin [dB]	Reading [dBm]	Antenna Gain + Array Gain [dBi]	Result
18	2483.507	54.6	74.0	19.4	-40.6	0.0	Passed
Operation Mode	Frequency [MHz]	Field Strength [dBuV/m]	Average Limit [dBuV/m]	Margin [dB]	Reading [dBm]	Antenna Gain + Array Gain [dBi]	Result
18	2483.502	46.4	54.0	7.6	-50.1	0.0	Passed
Measurement uncertainty				+0.66 dB / -0.72 dB			

UGXZEX304A (BT only module)

162097 BandEdgeRestr BT 2DH5 BT78.wmf: conducted band-edge compliance (operation mode 24):

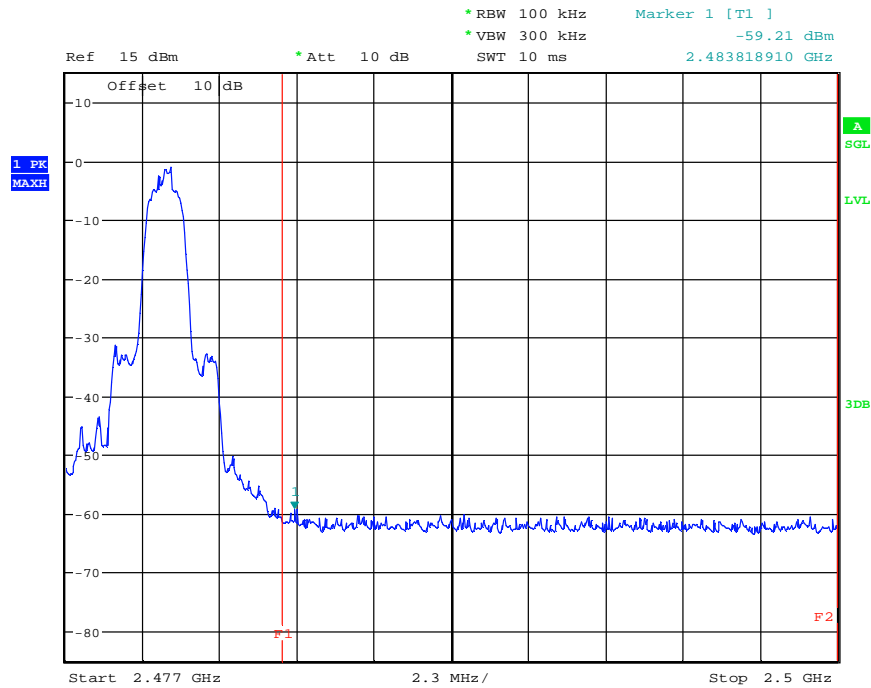

Band Edge Compliance, DH5-mode, channel 0, BT only module (Operation mode 19)							
Operation Mode	Frequency [MHz]	Field Strength [dBuV/m]	Peak Limit [dBuV/m]	Margin [dB]	Reading [dBm]	Antenna Gain + Array Gain [dBi]	Result
19	2373.823	41.2	74.0	32.8	-54.0	0.0	Passed
Operation Mode	Frequency [MHz]	Field Strength [dBuV/m]	Average Limit [dBuV/m]	Margin [dB]	Reading [dBm]	Antenna Gain + Array Gain [dBi]	Result
19	2375.958	32.1	54.0	21.9	-64.3	0.0	Passed
Measurement uncertainty				+0.66 dB / -0.72 dB			

Band Edge Compliance, DH5-mode, channel 78, BT only module (Operation mode 21)							
Operation Mode	Frequency [MHz]	Field Strength [dBuV/m]	Peak Limit [dBuV/m]	Margin [dB]	Reading [dBm]	Antenna Gain + Array Gain [dBi]	Result
21	2499.017	41.2	74.0	32.8	-54.1	0.0	Passed
Operation Mode	Frequency [MHz]	Field Strength [dBuV/m]	Average Limit [dBuV/m]	Margin [dB]	Reading [dBm]	Antenna Gain + Array Gain [dBi]	Result
121	2496.687	31.9	54.0	22.1	-64.6	0.0	Passed
Measurement uncertainty				+0.66 dB / -0.72 dB			

Band Edge Compliance, 2DH5-mode, channel 0, BT only module (Operation mode 22)							
Operation Mode	Frequency [MHz]	Field Strength [dBuV/m]	Peak Limit [dBuV/m]	Margin [dB]	Reading [dBm]	Antenna Gain + Array Gain [dBi]	Result
22	2375.852	40.6	74.0	33.4	-54.6	0.0	Passed
Operation Mode	Frequency [MHz]	Field Strength [dBuV/m]	Average Limit [dBuV/m]	Margin [dB]	Reading [dBm]	Antenna Gain + Array Gain [dBi]	Result
22	2375.832	31.7	54.0	22.3	-64.7	0.0	Passed
Measurement uncertainty				+0.66 dB / -0.72 dB			

Band Edge Compliance, 2DH5-mode, channel 78, BT only module (Operation mode 24)							
Operation Mode	Frequency [MHz]	Field Strength [dBuV/m]	Peak Limit [dBuV/m]	Margin [dB]	Reading [dBm]	Antenna Gain + Array Gain [dBi]	Result
24	2483.500	54.8	74.0	19.2	-40.5	0.0	Passed
Operation Mode	Frequency [MHz]	Field Strength [dBuV/m]	Average Limit [dBuV/m]	Margin [dB]	Reading [dBm]	Antenna Gain + Array Gain [dBi]	Result
24	2483.500	48.9	54.0	5.1	-47.5	0.0	Passed
Measurement uncertainty				+0.66 dB / -0.72 dB			

Band Edge Compliance, 3DH5-mode, channel 0, BT only module (Operation mode 25)							
Operation Mode	Frequency [MHz]	Field Strength [dBuV/m]	Peak Limit [dBuV/m]	Margin [dB]	Reading [dBm]	Antenna Gain + Array Gain [dBi]	Result
25	2370.006	41.7	74.0	32.3	-53.6	0.0	Passed
Operation Mode	Frequency [MHz]	Field Strength [dBuV/m]	Average Limit [dBuV/m]	Margin [dB]	Reading [dBm]	Antenna Gain + Array Gain [dBi]	Result
25	2372.066	32.2	54.0	21.8	-64.2	0.0	Passed
Measurement uncertainty				+0.66 dB / -0.72 dB			

Band Edge Compliance, 3DH5-mode, channel 78, BT only module (Operation mode 27)							
Operation Mode	Frequency [MHz]	Field Strength [dBuV/m]	Peak Limit [dBuV/m]	Margin [dB]	Reading [dBm]	Antenna Gain + Array Gain [dBi]	Result
27	2483.512	55.5	74.0	18.5	-39.8	0.0	Passed
Operation Mode	Frequency [MHz]	Field Strength [dBuV/m]	Average Limit [dBuV/m]	Margin [dB]	Reading [dBm]	Antenna Gain + Array Gain [dBi]	Result
27	2375.958	32.1	54.0	21.9	-64.3	0.0	Passed
Measurement uncertainty				+0.66 dB / -0.72 dB			

Test: Passed

TEST EQUIPMENT USED FOR THE TEST:

30

5.6 Maximum unwanted emissions

5.6.1 Method of measurement (conducted emissions in the restricted bands)

The relating measurements were carried out in a conducting manner. Therefore, the antenna connector was directly mounted to a spectrum analyser.

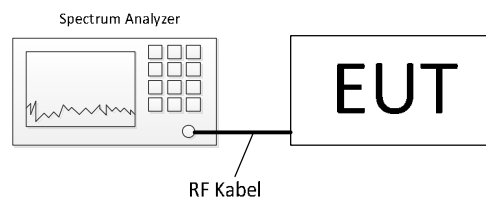

The measurement procedure refers to part 11.12.2.2 in document [1].

If emissions were detected during the preliminary measurements, they were measured using the following measurement procedures:

Procedure for average measurement: 11.12.2.5.2 – Trace averaging across ON and OFF times of the EUT transmissions followed by duty cycle correction:

If continuous transmission of the EUT ($D \geq 98\%$) cannot be achieved and the duty cycle is constant (duty cycle variations are less than $\pm 2\%$), then the following procedure shall be used:

- The EUT shall be configured to operate at the maximum achievable duty cycle.
- Measure the duty cycle D of the transmitter output signal as described in 11.6 in [1].
- Set the RBW = 1 MHz (unless otherwise specified).
- Set the VBW $\geq 3 \times$ RBW.
- Detector = power average (RMS).
- Ensure that the number of measurement points in the sweep to $\geq 2 \times$ (span/RBW).
- Averaging type = power
- Sweep time = auto
- Perform a trace average of at least 100 traces
- Correct the resulting measurement value by adding the duty cycle correction value if applicable.

Peak measurement procedure: 11.12.2.4 in [1]

- Set the analyzer span to encompass the entire unwanted emission bandwidth.
- Set the RBW = specified in Table 1.
- Set the VBW \geq RBW.
- Set sweep time = auto.
- Detector = peak.
- Trace mode = max hold.
- Allow the trace to stabilize.
- Use the peak marker function to determine the peak power over the emission bandwidth.

Table 1 RBW as a function of frequency

Frequency	RBW
9-150 kHz	200-300 Hz
0.15-30 MHz	9-10 kHz
30-1000 MHz	100-120 kHz
> 1000 MHz	1 MHz

5.6.1.1 Limit calculations

The following general procedure is described in chapter 11.12.2.2 in [1].

- Measure the conducted output power (in dBm) using the detector specified by the appropriate regulatory agency (see 11.12.2.3 through 11.12.2.5 for guidance regarding measurement procedures for determining quasi-peak, peak, and average conducted output power, respectively).
- Add the maximum transmit antenna gain (in dBi) to the measured output power level to determine the EIRP (see 11.12.2.6 for guidance on determining the applicable antenna gain).
- Add the appropriate maximum ground reflection factor to the EIRP (6 dB for frequencies ≤ 30 MHz; 4.7 dB for frequencies between 30 MHz and 1000 MHz, inclusive; and 0 dB for frequencies > 1000 MHz).
- For MIMO devices, measure the power of each chain and sum the EIRP of all chains in linear terms (i.e., watts and mW).
- Convert the resultant EIRP to an equivalent electric field strength using the following relationship:

$$E. = EIRP - 20\log(d) + 104.8 \quad (1)$$

where

E is the electric field strength in dB μ V/m
 EIRP is the equivalent isotropically radiated power in dBm
 d is the specified measurement distance in m

- Compare the resultant electric field strength level with the applicable regulatory limit.
- Perform the radiated spurious emission test.

Chapter 14 in [1] states, that for transmitters with multiple outputs in the same band, summing of emissions and accounting for array gain have to be considered.

For the case that both antenna ports transmit continuously, both results were summed as linear values as described in 14.3.2.2 in document [1].

To account for directional gain which might occur in case of N transmit antennas in the test mode spatial multiplexing, which is the mode the EUT uses, the directional has to be calculated as:

$$10\log \left[\sum_{j=1}^{N_{SS}} \left\{ \sum_{k=1}^{N_{Ant}} g_{j,k} \right\}^2 / N_{Ant} \right]$$

Whereby

N_{SS} is the number of independent spatial streams of data.
 N_{Ant} is the total number of antennas
 $g_{j,k}$ is $10^{G_k/20}$ if the k th antenna is being fed by spatial stream j , or zero if it is not
 G_k is the gain in dBi of the k th antenna

For the antennas of this EUT which have 5 and 2 dBi antenna gain, the combined antenna gain results in a value of 3.8 dBi directional antenna gain.

5.6.2 Method of measurement (conducted emissions in the unrestricted bands)

In any 100 kHz outside the authorized frequency band, the power shall be attenuated by 20 dB, compared to the highest in band power in any 100 kHz. This shall be demonstrated by using the peak power procedure. The reference level shall be measured using the procedure described in 5.6.2.1 and the emission level according to procedure 5.6.2.2. The procedures are based on chapter 11.11.2 and 11.11.3 in [1].

For the operation modes in which both antenna ports transmit simultaneously, the level of the both ports were summed in linear value for each frequency step. The applicable plots show the result of that sum.

5.6.2.1 Reference level measurement

- a) Set instrument center frequency to DTS channel center frequency.
- b) Set the span to ≥ 1.5 times the DTS bandwidth.
- c) Set the RBW = 100 kHz.
- d) Set the VBW $\geq 3 \times$ RBW.
- e) Detector = peak.
- f) Sweep time = auto couple.
- g) Trace mode = max hold.
- h) Allow trace to fully stabilize.
- i) Use the peak marker function to determine the maximum PSD level.

5.6.2.2 Emission level measurement

- a) Set the center frequency and span to encompass frequency range to be measured.
- b) Set the RBW = 100 kHz.
- c) Set the VBW $\geq 3 \times$ RBW.
- d) Detector = peak.
- e) Ensure that the number of measurement points \geq span/RBW
- f) Sweep time = auto couple.
- g) Trace mode = max hold.
- h) Allow trace to fully stabilize.
- i) Use the peak marker function to determine the maximum amplitude level.

5.6.3 Test results (conducted emissions)

5.6.3.1 Emissions below 1 GHz

No significant emissions were found below 1 GHz, therefore no plots and result tables for this frequency range are submitted below. If no emissions were found, an exemplary plot is submitted.

5.6.3.2 Emissions above 1 GHz

Ambient temperature	22 °C	Relative humidity	59 %
---------------------	-------	-------------------	------

The following results were measured at antenna port of the EUT. Only the plots for the worst case emissions are submitted below.

UGKZ7A1001A (BT/WLAN combi module) with WLAN mode active

162097 SpurEmiss1-4G b 11.wmf: conducted spurious emissions (operation mode 3):

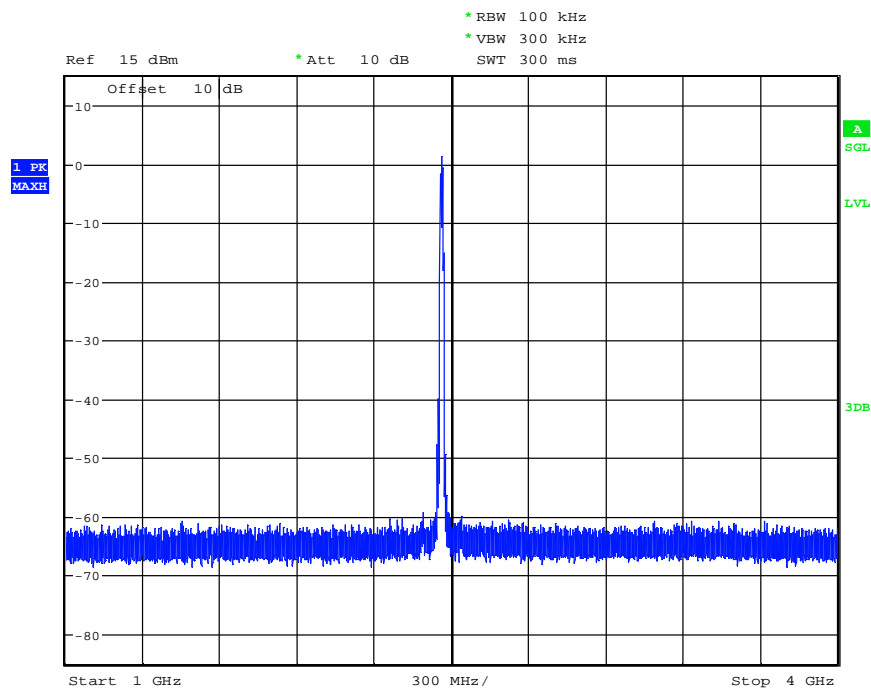

162097_SpurEmiss4-12G_b_11.wmf: conducted spurious emissions (operation mode 3):

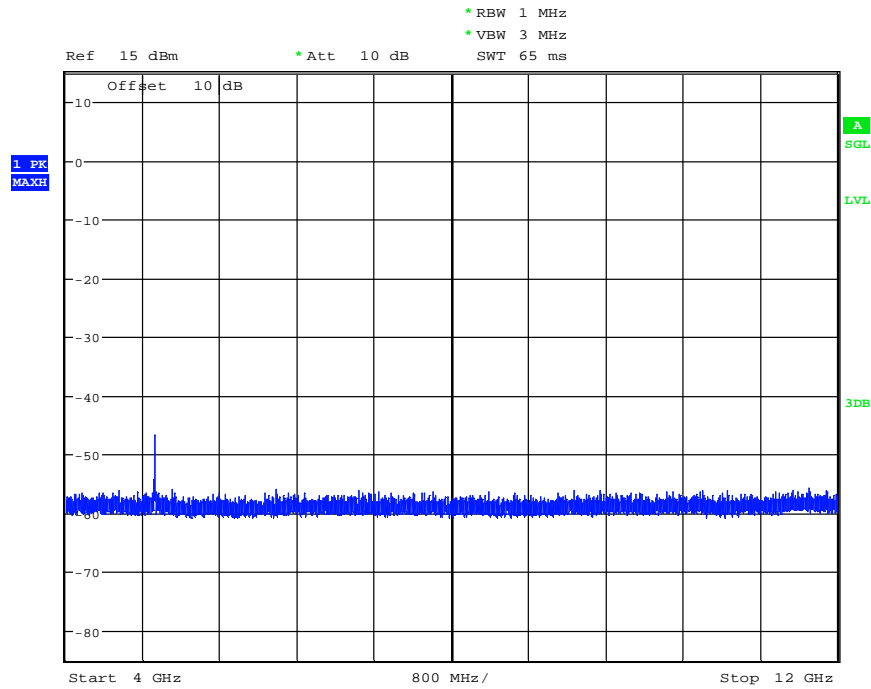

162097_SpurEmiss12-18G_b_11.wmf: conducted spurious emissions (operation mode 3):

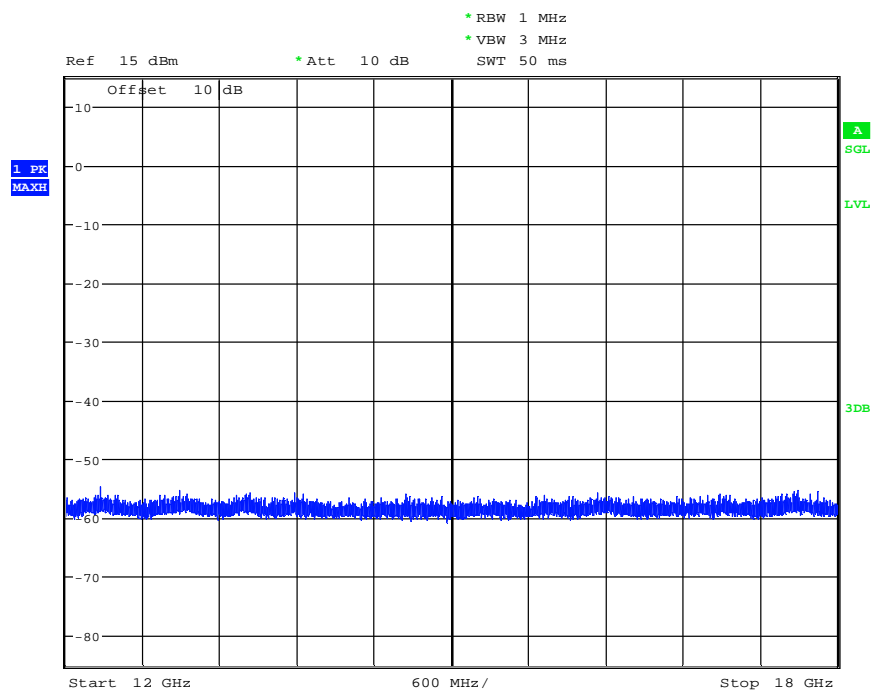

162097_SpurEmiss18-26G_b_11.wmf: conducted spurious emissions (operation mode 3):

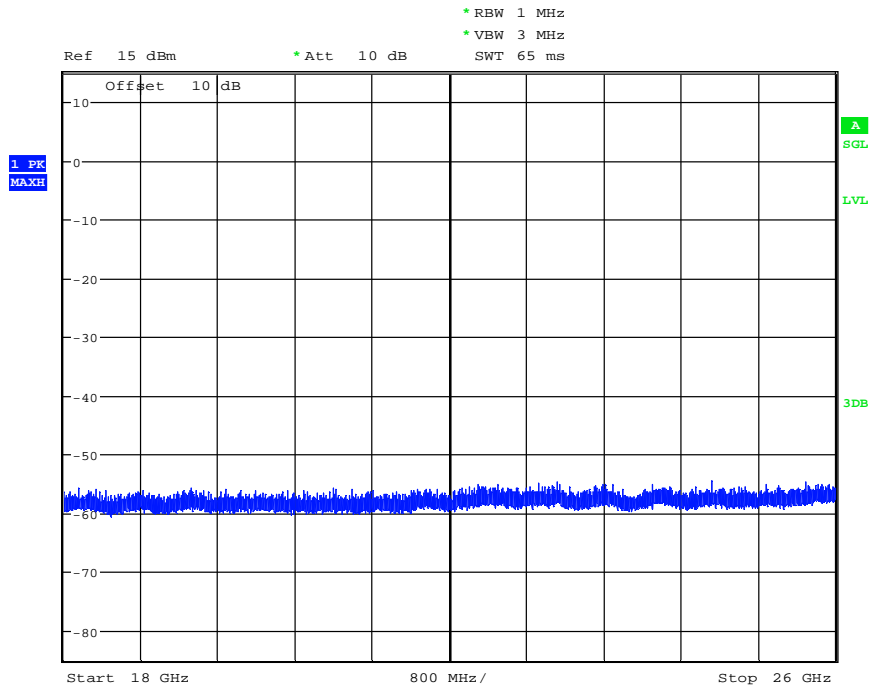

Spurious Emissions, b-mode, channel 1, BT/WLAN module (Operation mode 1)							
Peak Emission – Restricted Band							
Operation Mode	Frequency [MHz]	Field Strength [dBuV/m]	Peak Limit [dBuV/m]	Margin [dB]	Reading [dBm]	Antenna Gain + Array Gain [dBi]	Result
1	4824.05	50.3	74.0	23.7	-44.9	0.0	Passed
Average Emission – Restricted Band							
Operation Mode	Frequency [MHz]	Field Strength [dBuV/m]	Average Limit [dBuV/m]	Margin [dB]	Reading [dBm]	Antenna Gain + Array Gain [dBi]	Result
1	4823.96	45.7	54.0	8.3	-49.6	0.0	Passed
Emissions in the non-restricted Bands							
No emissions found							
Measurement uncertainty				+0.66 dB / -0.72 dB			

Spurious Emissions, b-mode, channel 6, BT/WLAN module (Operation mode 2)							
Peak Emission – Restricted Band							
Operation Mode	Frequency [MHz]	Field Strength [dBuV/m]	Peak Limit [dBuV/m]	Margin [dB]	Reading [dBm]	Antenna Gain + Array Gain [dBi]	Result
2	4873.88	50.6	74.0	23.4	-44.7	0.0	Passed
Average Emission – Restricted Band							
Operation Mode	Frequency [MHz]	Field Strength [dBuV/m]	Average Limit [dBuV/m]	Margin [dB]	Reading [dBm]	Antenna Gain + Array Gain [dBi]	Result
2	4873.91	46.8	54.0	7.2	-48.5	0.0	Passed
Emissions in the non-restricted Bands							
No emissions found							
Measurement uncertainty				+0.66 dB / -0.72 dB			

Spurious Emissions, b-mode, channel 11, BT/WLAN module (Operation mode 3)							
Peak Emission – Restricted Band							
Operation Mode	Frequency [MHz]	Field Strength [dBuV/m]	Peak Limit [dBuV/m]	Margin [dB]	Reading [dBm]	Antenna Gain + Array Gain [dBi]	Result
3	4923.87	51.4	74.0	22.6	-43.9	0.0	Passed
Average Emission – Restricted Band							
Operation Mode	Frequency [MHz]	Field Strength [dBuV/m]	Average Limit [dBuV/m]	Margin [dB]	Reading [dBm]	Antenna Gain + Array Gain [dBi]	Result
3	4923.95	48.0	54.0	6.0	-47.2	0.0	Passed
Emissions in the non-restricted Bands							
No emissions found							
Measurement uncertainty				+0.66 dB / -0.72 dB			

Spurious Emissions, g-mode, channel 1, BT/WLAN module (Operation mode 4)							
Peak Emission – Restricted Band							
Operation Mode	Frequency [MHz]	Field Strength [dBuV/m]	Peak Limit [dBuV/m]	Margin [dB]	Reading [dBm]	Antenna Gain + Array Gain [dBi]	Result
4	4825.64	47.6	74.0	26.4	-47.7	0.0	Passed
Average Emission – Restricted Band							
Operation Mode	Frequency [MHz]	Field Strength [dBuV/m]	Average Limit [dBuV/m]	Margin [dB]	Reading [dBm]	Antenna Gain + Array Gain [dBi]	Result
4	4824.03	35.2	54.0	18.8	-60.1	0.0	Passed
Emissions in the non-restricted Bands							
No emissions found							
Measurement uncertainty				+0.66 dB / -0.72 dB			

Spurious Emissions, g-mode, channel 6, BT/WLAN module (Operation mode 5)							
Peak Emission – Restricted Band							
Operation Mode	Frequency [MHz]	Field Strength [dBuV/m]	Peak Limit [dBuV/m]	Margin [dB]	Reading [dBm]	Antenna Gain + Array Gain [dBi]	Result
5	4876.38	48.8	74.0	25.2	-46.4	0.0	Passed
Average Emission – Restricted Band							
Operation Mode	Frequency [MHz]	Field Strength [dBuV/m]	Average Limit [dBuV/m]	Margin [dB]	Reading [dBm]	Antenna Gain + Array Gain [dBi]	Result
5	4874.07	36.1	54.0	17.9	-59.2	0.0	Passed
Emissions in the non-restricted Bands							
No emissions found							
Measurement uncertainty				+0.66 dB / -0.72 dB			

Spurious Emissions, g-mode, channel 11, BT/WLAN module (Operation mode 6)							
Peak Emission – Restricted Band							
Operation Mode	Frequency [MHz]	Field Strength [dBuV/m]	Peak Limit [dBuV/m]	Margin [dB]	Reading [dBm]	Antenna Gain + Array Gain [dBi]	Result
6	4922.5	49.7	74.0	24.3	-45.5	0.0	Passed
Average Emission – Restricted Band							
Operation Mode	Frequency [MHz]	Field Strength [dBuV/m]	Average Limit [dBuV/m]	Margin [dB]	Reading [dBm]	Antenna Gain + Array Gain [dBi]	Result
6	4923.8	36.8	54.0	17.2	-58.5	0.0	Passed
Emissions in the non-restricted Bands							
No emissions found							
Measurement uncertainty				+0.66 dB / -0.72 dB			

Spurious Emissions, n20-mode, channel 1, BT/WLAN module (Operation mode 7)							
Peak Emission – Restricted Band							
Operation Mode	Frequency [MHz]	Field Strength [dBuV/m]	Peak Limit [dBuV/m]	Margin [dB]	Reading [dBm]	Antenna Gain + Array Gain [dBi]	Result
7	4827.79	47.0	74.0	27.0	-48.3	0.0	Passed
Average Emission – Restricted Band							
Operation Mode	Frequency [MHz]	Field Strength [dBuV/m]	Average Limit [dBuV/m]	Margin [dB]	Reading [dBm]	Antenna Gain + Array Gain [dBi]	Result
7	4823.91	35.0	54.0	19.0	-60.3	0.0	Passed
Emissions in the non-restricted Bands							
No emissions found							
Measurement uncertainty				+0.66 dB / -0.72 dB			

Spurious Emissions, n20-mode, channel 6, BT/WLAN module (Operation mode 8)							
Peak Emission – Restricted Band							
Operation Mode	Frequency [MHz]	Field Strength [dBuV/m]	Peak Limit [dBuV/m]	Margin [dB]	Reading [dBm]	Antenna Gain + Array Gain [dBi]	Result
8	4874.48	48.2	74.0	25.8	-47.0	0.0	Passed
Average Emission – Restricted Band							
Operation Mode	Frequency [MHz]	Field Strength [dBuV/m]	Average Limit [dBuV/m]	Margin [dB]	Reading [dBm]	Antenna Gain + Array Gain [dBi]	Result
8	4873.84	35.9	54.0	18.1	-59.3	0.0	Passed
Emissions in the non-restricted Bands							
No emissions found							
Measurement uncertainty				+0.66 dB / -0.72 dB			

Spurious Emissions, n20-mode, channel 11, BT/WLAN module (Operation mode 9)							
Peak Emission – Restricted Band							
Operation Mode	Frequency [MHz]	Field Strength [dBuV/m]	Peak Limit [dBuV/m]	Margin [dB]	Reading [dBm]	Antenna Gain + Array Gain [dBi]	Result
9	4925.2	50.0	74.0	24.0	-45.2	0.0	Passed
Average Emission – Restricted Band							
Operation Mode	Frequency [MHz]	Field Strength [dBuV/m]	Average Limit [dBuV/m]	Margin [dB]	Reading [dBm]	Antenna Gain + Array Gain [dBi]	Result
9	4924.1	36.5	54.0	17.5	-58.8	0.0	Passed
Emissions in the non-restricted Bands							
No emissions found							
Measurement uncertainty				+0.66 dB / -0.72 dB			

UGKZ7A1001A (BT/WLAN combi module) with Bluetooth mode active

162097_SpurEmiss1-4G_BT_DH5_BT39.wmf: conducted spurious emissions (operation mode 11):

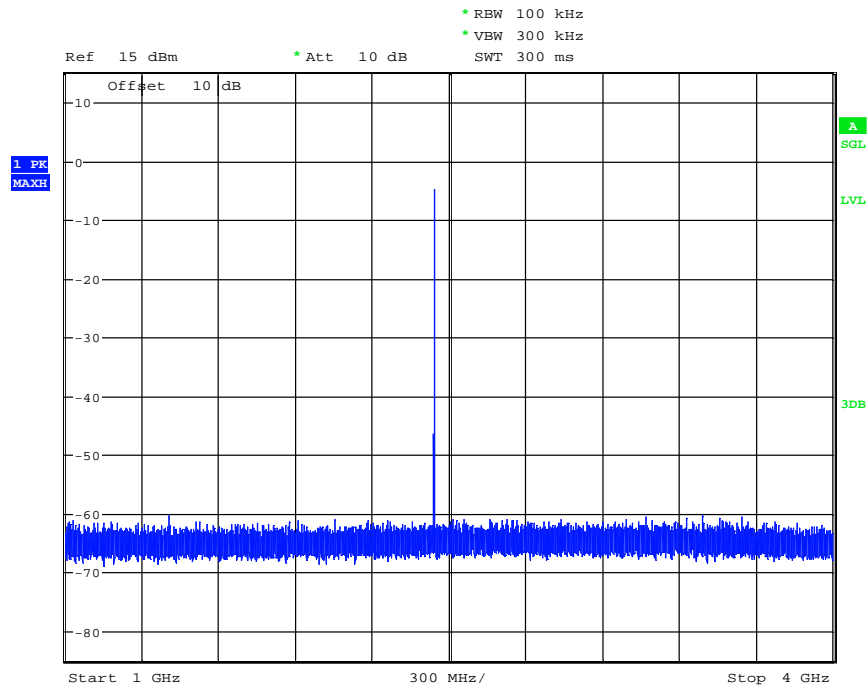

162097_SpurEmiss4-12G_BT_2DH5_BT39.wmf: conducted spurious emissions (operation mode 11):

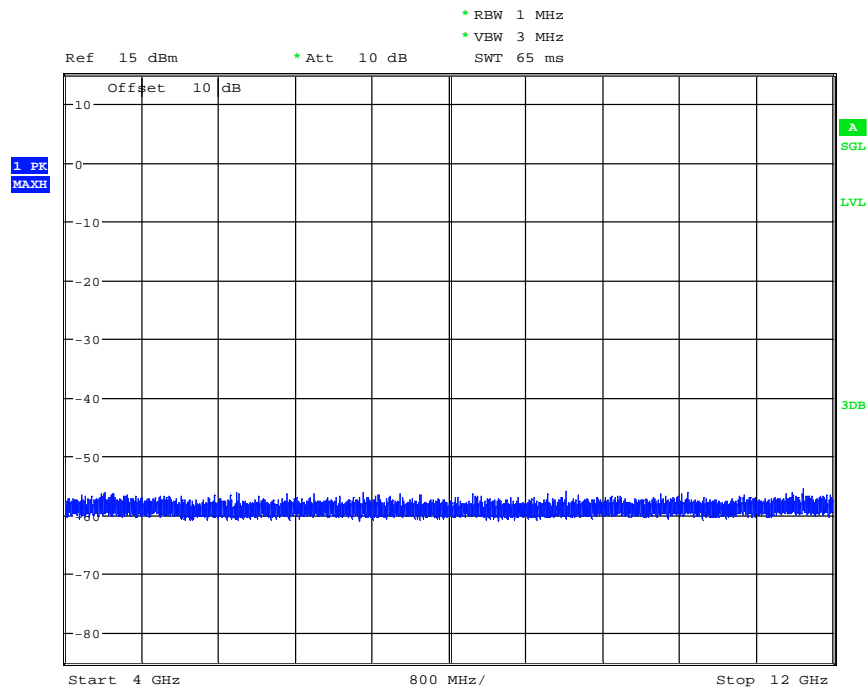

162097_SpurEmiss12-18G_BT_DH5_BT39.wmf: conducted spurious emissions (operation mode 11):

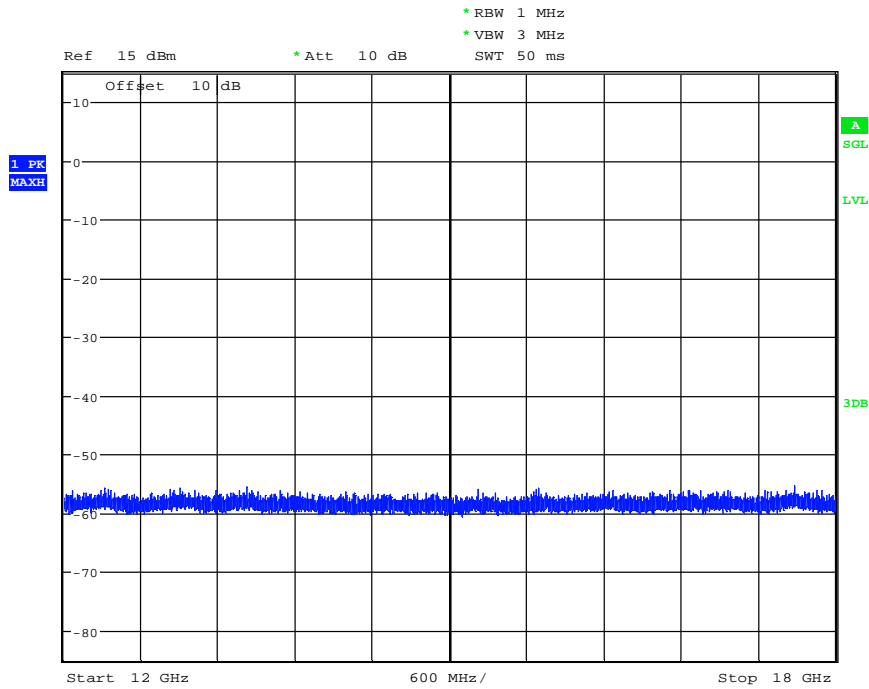

162097_SpurEmiss18-26G_BT_DH5_BT39.wmf: conducted spurious emissions (operation mode 11):

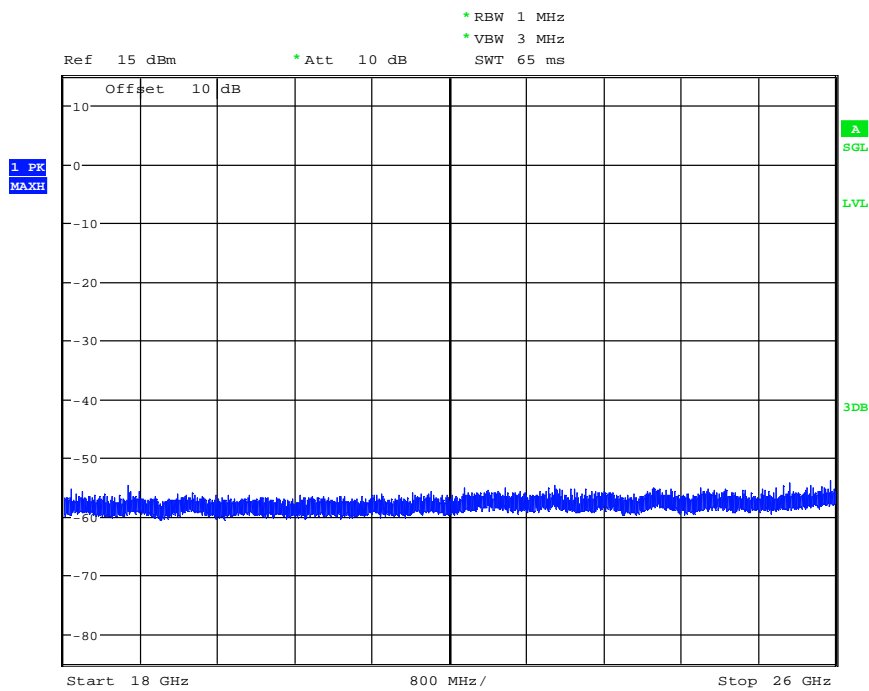

Spurious Emissions, DH5-mode, channel 0, BT/WLAN module (Operation mode 10)

No spurious emissions found during the preliminary measurements

Spurious Emissions, DH5-mode, channel 39, BT/WLAN module (Operation mode 11)

No spurious emissions found during the preliminary measurements

Spurious Emissions, DH5-mode, channel 78, BT/WLAN module (Operation mode 12)

No spurious emissions found during the preliminary measurements

Spurious Emissions, 2DH5-mode, channel 0, BT/WLAN module (Operation mode 13)

No spurious emissions found during the preliminary measurements

Spurious Emissions, 2DH5-mode, channel 39, BT/WLAN module (Operation mode 14)

No spurious emissions found during the preliminary measurements

Spurious Emissions, 2DH5-mode, channel 78, BT/WLAN module (Operation mode 15)

No spurious emissions found during the preliminary measurements

Spurious Emissions, 3DH5-mode, channel 0, BT/WLAN module (Operation mode 16)

No spurious emissions found during the preliminary measurements

Spurious Emissions, 3DH5-mode, channel 39, BT/WLAN module (Operation mode 17)

No spurious emissions found during the preliminary measurements

Spurious Emissions, 3DH5-mode, channel 78, BT/WLAN module (Operation mode 18)

No spurious emissions found during the preliminary measurements

UGXZEX304A (BT only module)

162097_SpurEmiss1-4G_BT_3DH5_BT79.wmf: conducted spurious emissions (operation mode 27):

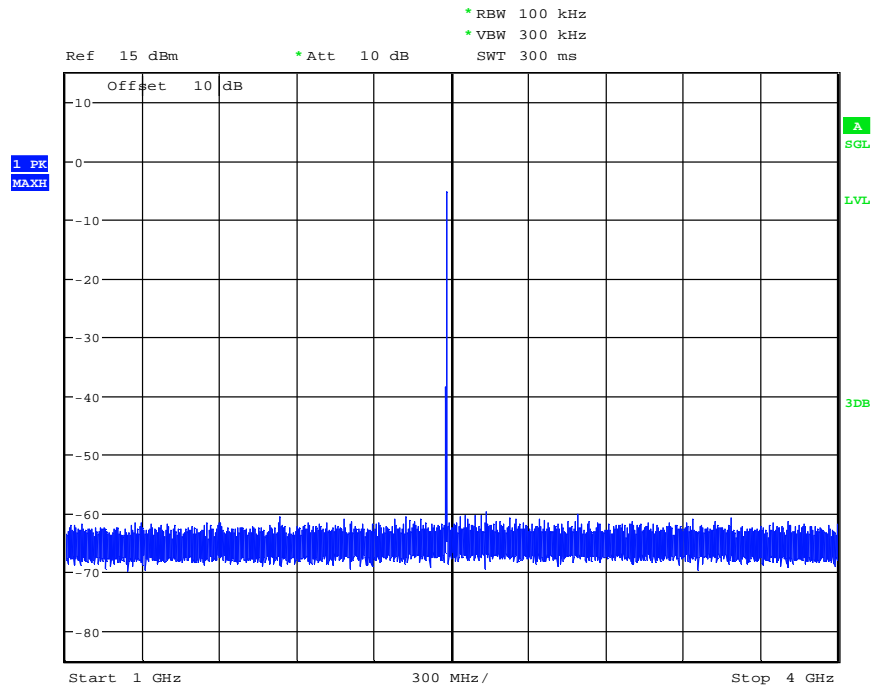

162097_SpurEmiss4-12G_BT_3DH5_BT79.wmf: conducted spurious emissions (operation mode 27):

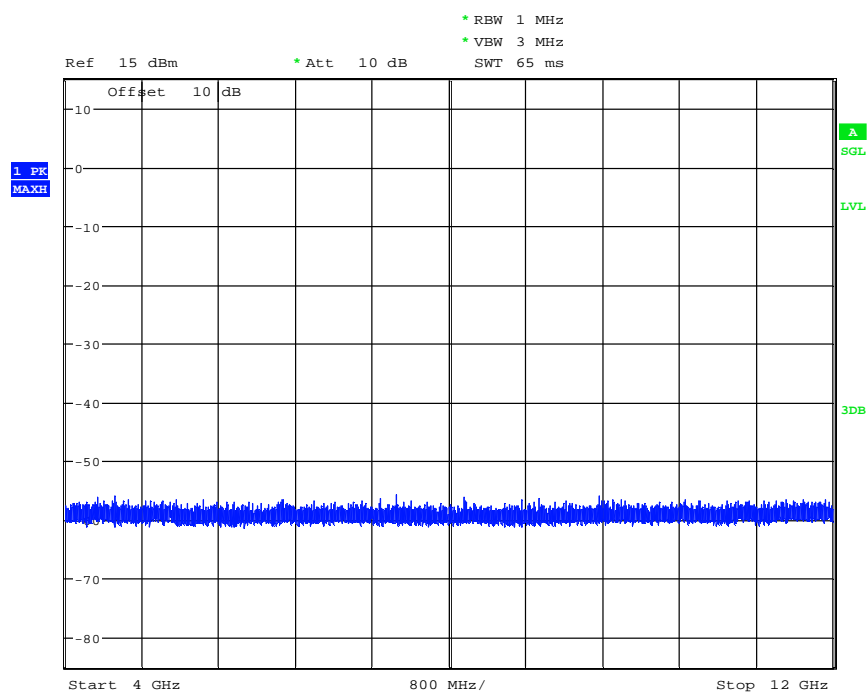

162097_SpurEmiss12-18G_BT_DH5_BT79.wmf: conducted spurious emissions (operation mode 27):

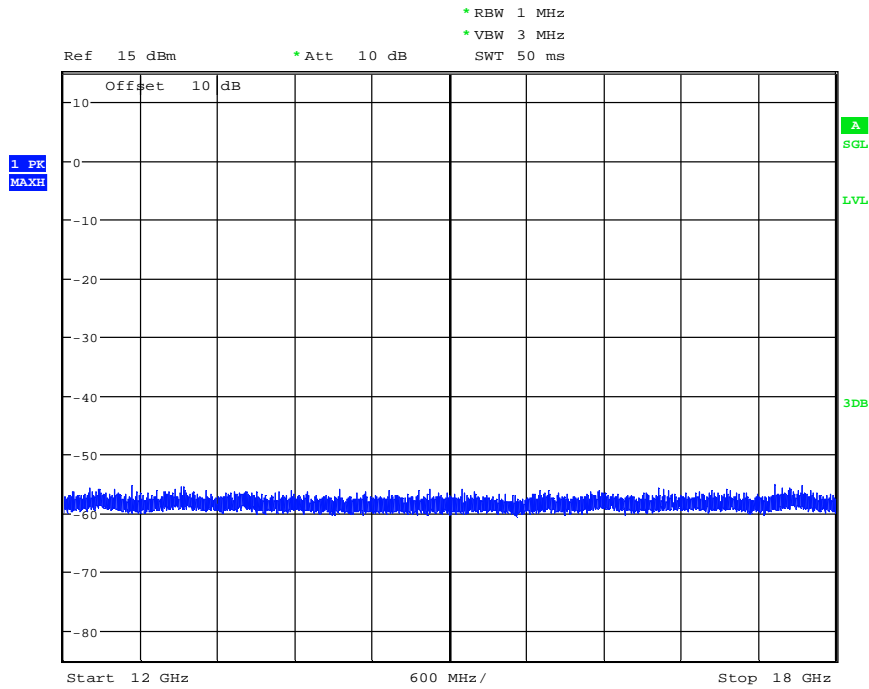

162097_SpurEmiss18-26G_BT_3DH5_BT79.wmf: conducted spurious emissions (operation mode 27):

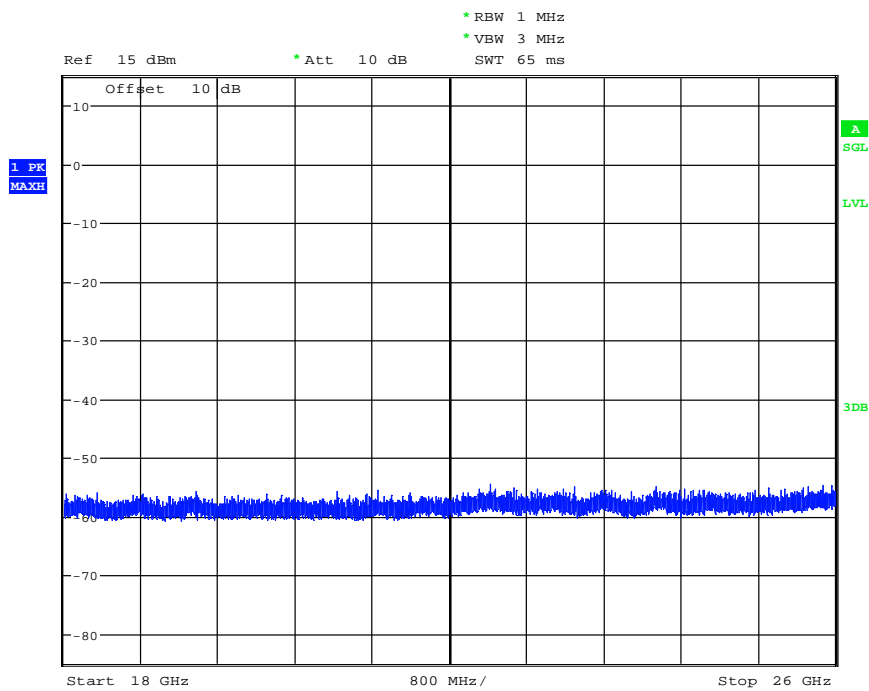

Spurious Emissions, DH5-mode, channel 0, BT only module (Operation mode 19)					
No spurious emissions in the restricted bands were found during the preliminary measurements					
Emissions in the non-restricted Bands					
Operation Mode	Frequency [MHz]	Reading [dBm]	Limit [dBm]	Margin [dB]	Result
19	2402.160	-0.1	-	-	-
19	2558.030	-52.6	-20.1	32.4	Passed
19	2532.150	-55.1	-20.1	35.0	Passed
Measurement uncertainty			+0.66 dB / -0.72 dB		

Spurious Emissions, DH5-mode, channel 39, BT only module (Operation mode 20)					
No spurious emissions in the restricted bands were found during the preliminary measurements					
Emissions in the non-restricted Bands					
Operation Mode	Frequency [MHz]	Reading [dBm]	Limit [dBm]	Margin [dB]	Result
20	2441.040	0.9	-	-	-
20	2597.070	-53.6	-19.1	34.5	Passed
Measurement uncertainty			+0.66 dB / -0.72 dB		

Spurious Emissions, DH5-mode, channel 78, BT only module (Operation mode 21)					
No spurious emissions in the restricted bands were found during the preliminary measurements					
Emissions in the non-restricted Bands					
Operation Mode	Frequency [MHz]	Reading [dBm]	Limit [dBm]	Margin [dB]	Result
21	2479.830	1.3	-	-	-
21	2635.990	-55.1	-18.7	36.4	Passed
Measurement uncertainty			+0.66 dB / -0.72 dB		

Spurious Emissions, 2DH5-mode, channel 0, BT only module (Operation mode 22)					
No spurious emissions in the restricted bands were found during the preliminary measurements					
Emissions in the non-restricted Bands					
Operation Mode	Frequency [MHz]	Reading [dBm]	Limit [dBm]	Margin [dB]	Result
22	2402.000	-1.8	-	-	-
22	2557.970	-54.4	-21.8	32.7	Passed
Measurement uncertainty			+0.66 dB / -0.72 dB		

Spurious Emissions, 2DH5-mode, channel 39, BT only module (Operation mode 23)					
No spurious emissions in the restricted bands were found during the preliminary measurements					
Emissions in the non-restricted Bands					
Operation Mode	Frequency [MHz]	Reading [dBm]	Limit [dBm]	Margin [dB]	Result
23	2441.010	-0.3	-	-	-
23	2596.980	-55.9	-20.3	35.6	Passed
Measurement uncertainty			+0.66 dB / -0.72 dB		

Spurious Emissions, 2DH5-mode, channel 78, BT only module (Operation mode 24)							
Peak Emission – Restricted Band							
Operation Mode	Frequency [MHz]	Field Strength [dBuV/m]	Peak Limit [dBuV/m]	Margin [dB]	Reading [dBm]	Antenna Gain + Array Gain [dBi]	Result
24	2323.540	43.5	74.0	30.5	-51.8	0.0	Passed
Average Emission – Restricted Band							
Operation Mode	Frequency [MHz]	Field Strength [dBuV/m]	Average Limit [dBuV/m]	Margin [dB]	Reading [dBm]	Antenna Gain + Array Gain [dBi]	Result
24	2323.980	35.9	54.0	18.1	-60.6	0.0	Passed
Emissions in the non-restricted Bands							
Operation Mode	Frequency [MHz]	Reading [dBm]	Limit [dBm]	Margin [dB]			Result
24	2479.990	0.2	-	-			-
24	2635.980	-56.3	-19.8	36.5			Passed
Measurement uncertainty					+0.66 dB / -0.72 dB		

Spurious Emissions, 3DH5-mode, channel 0, BT only module (Operation mode 25)					
No spurious emissions in the restricted bands were found during the preliminary measurements					
Emissions in the non-restricted Bands					
Operation Mode	Frequency [MHz]	Reading [dBm]	Limit [dBm]	Margin [dB]	Result
25	2401.840	-0.5	-	-	-
25	2558.030	-51.8	-20.5	31.3	Passed
Measurement uncertainty			+0.66 dB / -0.72 dB		

Spurious Emissions, 3DH5-mode, channel 39, BT only module (Operation mode 26)							
Peak Emission – Restricted Band							
Operation Mode	Frequency [MHz]	Field Strength [dBuV/m]	Peak Limit [dBuV/m]	Margin [dB]	Reading [dBm]	Antenna Gain + Array Gain [dBi]	Result
26	2284.870	43.1	74.0	30.9	-52.2	0.0	Passed
Average Emission – Restricted Band							
Operation Mode	Frequency [MHz]	Field Strength [dBuV/m]	Average Limit [dBuV/m]	Margin [dB]	Reading [dBm]	Antenna Gain + Array Gain [dBi]	Result
26	2284.910	35.1	54.0	18.9	-61.3	0.0	Passed
Emissions in the non-restricted Bands							
Operation Mode	Frequency [MHz]	Reading [dBm]	Limit [dBm]	Margin [dB]			Result
26	2440.830	1.7	-	-			-
26	2597.100	-54.9	-18.3	36.6			Passed
Measurement uncertainty					+0.66 dB / -0.72 dB		

Spurious Emissions, 3DH5-mode, channel 78, BT only module (Operation mode 27)							
Peak Emission – Restricted Band							
Operation Mode	Frequency [MHz]	Field Strength [dBuV/m]	Peak Limit [dBuV/m]	Margin [dB]	Reading [dBm]	Antenna Gain + Array Gain [dBi]	Result
27	2323.610	44.4	74.0	29.6	-50.9	0.0	Passed
Average Emission – Restricted Band							
Operation Mode	Frequency [MHz]	Field Strength [dBuV/m]	Average Limit [dBuV/m]	Margin [dB]	Reading [dBm]	Antenna Gain + Array Gain [dBi]	Result
27	2323.780	37.0	54.0	17.0	-59.5	0.0	Passed
Emissions in the non-restricted Bands							
Operation Mode	Frequency [MHz]	Reading [dBm]	Limit [dBm]	Margin [dB]			Result
27	2479.830	1.4	-	-			-
27	2635.830	-53.9	-18.6	35.3			Passed
Measurement uncertainty				+0.66 dB / -0.72 dB			

Test: Passed

TEST EQUIPMENT USED FOR THE TEST:

30

5.6.4 Method of measurement (radiated emissions)

The radiated emission measurement is subdivided into five stages.

- A preliminary measurement carried out in a fully anechoic chamber with a fixed antenna height in the frequency range 9 kHz to 1 GHz.
- A final measurement carried out on an outdoor test site without reflecting ground plane and a fixed antenna height in the frequency range 9 kHz to 30 MHz.
- A final measurement carried out on an open area test site with reflecting ground plane and various antenna height in the frequency range 30 MHz to 1 GHz.
- A preliminary measurement carried out in a fully anechoic chamber with a variable antenna distance and height in the frequency range 1 GHz to 25 / 40 GHz.
- A final measurement carried out in a fully anechoic chamber with a fixed antenna height in the frequency range 1 GHz to 25 / 40 GHz.

Preliminary measurement (9 kHz to 30 MHz):

In the first stage a preliminary measurement will be performed in a shielded room with a measuring distance of 3 meters. Tabletop and modular devices will be set up on a EUT turn device on a height of 1.5 m and a height of 80 cm. Floor-standing devices will be placed directly on the turntable/ground plane. The setup of the Equipment under test will be in accordance to [1].

The frequency range 9 kHz to 30 MHz will be monitored with a spectrum analyser while the system and its cables will be manipulated to find out the configuration with the maximum emission levels if applicable. The EMI Receiver will be set to MAX Hold mode. The EUT and the measuring antenna will be rotated around their vertical axis to found the maximum emissions.

The resolution bandwidth of the spectrum analyzer will be set to the following values:

Frequency range	Resolution bandwidth
9 kHz to 150 kHz	200 Hz
150 kHz to 30 MHz	10 kHz

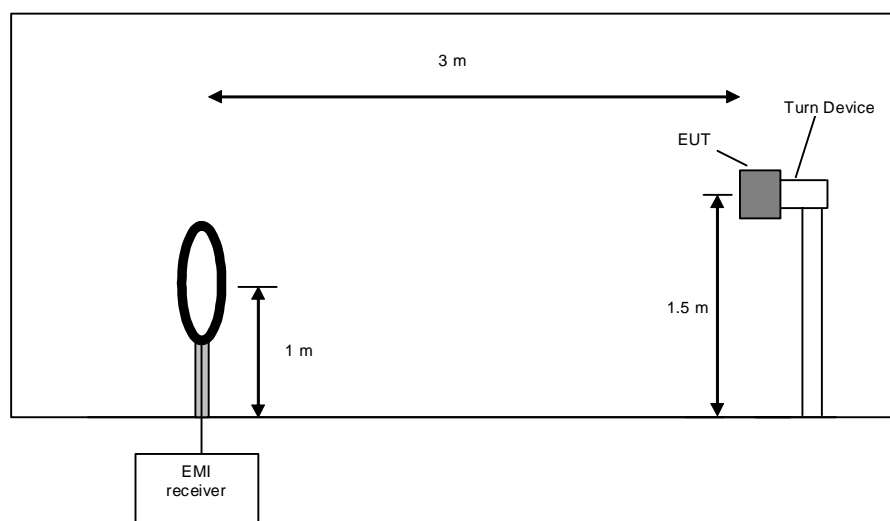

Preliminary measurement procedure:

Prescans were performed in the frequency range 9 kHz to 150 kHz and 150 kHz to 30 MHz.

The following procedure will be used:

- 1) Monitor the frequency range at horizontal polarization and a EUT azimuth of 0 °.
- 2) Manipulate the system cables within the range to produce the maximum level of emission.
- 3) Rotate the EUT by 360 ° to maximize the detected signals.
- 4) Make a hardcopy of the spectrum.
- 5) Measure the frequencies of highest detected emission with a lower span and resolution bandwidth to increase the accuracy and note the frequency value.
- 6) Repeat steps 1) to 5) with the other orthogonal axes of the EUT (because of EUT is a module and might be used in a handheld equipment application).
- 7) Rotate the measuring antenna and repeat steps 1) to 5).

Final measurement (9 kHz to 30 MHz):

In the second stage a final measurement will be performed on an open area test site with no conducting ground plane in measuring distances of 3 m, 10 m and 30 m. In the cases where larger measuring distances are required the results will be extrapolated based on the values measured on the closer distances according to Section 15.31 (f) (2) [2]. The final measurement will be performed with a EMI Receiver set to Quasi Peak detector except for the frequency bands 9 kHz to 90 kHz and 110 kHz to 490 kHz where an average detector will be used according Section 15.209 (d) [2].

On the frequencies, which were detected during the preliminary measurements, the final measurement will be performed while rotating the EUT and the measuring antenna in the range of 0 ° to 360 ° around their vertical axis until the maximum value is found.

The resolution bandwidth of the EMI Receiver will be set to the following values:

Frequency range	Resolution bandwidth
9 kHz to 150 kHz	200 Hz
150 kHz to 30 MHz	9 kHz

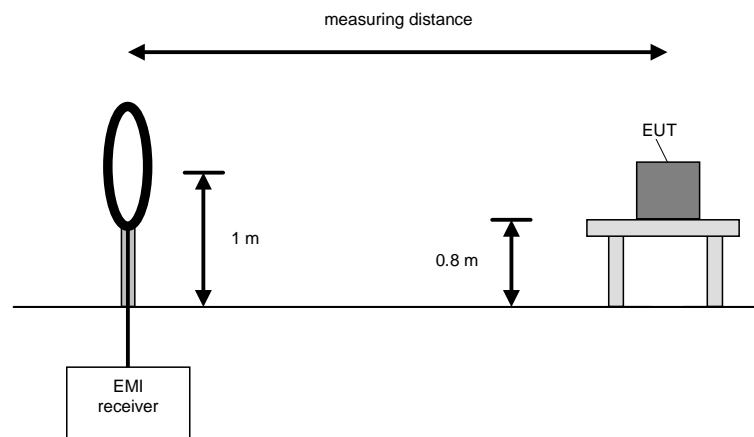

Final measurement procedure:

The following procedure will be used:

- 1) Monitor the frequency range with the measuring antenna at vertical orientation parallel to the EUT at an azimuth of 0 °.
- 2) Rotate the EUT by 360 ° to maximize the detected signals and note the azimuth and orientation.
- 3) Rotate the measuring antenna to find the maximum and note the value.
- 4) Rotate the measuring antenna and repeat steps 1) to 3) until the maximum value is found.
- 5) Repeat steps 1) to 4) with the other orthogonal axes of the EUT (if the EUT is a module and might be used in a handheld equipment application).

Preliminary measurement (30 MHz to 1 GHz)

In the first stage a preliminary measurement will be performed in a fully anechoic chamber with a measuring distance of 3 meter. Table top devices will set up on a non-conducting turn device on the height of 1.5m. Floor-standing devices will be placed directly on the turntable/ground plane. The set up of the Equipment under test will be in accordance to [1].

The frequency range 30 MHz to 1 GHz will be measured with an EMI Receiver set to MAX Hold mode and a resolution bandwidth of 100 kHz. The measurement will be performed in horizontal and vertical polarisation of the measuring antenna and while rotating the EUT in its vertical axis in the range of 0 ° to 360 °. This measurement is repeated after raising the EUT in 30° steps according 6.6.5.4 in [1].

The resolution bandwidth of the EMI Receiver will be set to the following values:

Frequency range	Resolution bandwidth
30 MHz to 230 MHz	100 kHz
230 MHz to 1 GHz	100 kHz

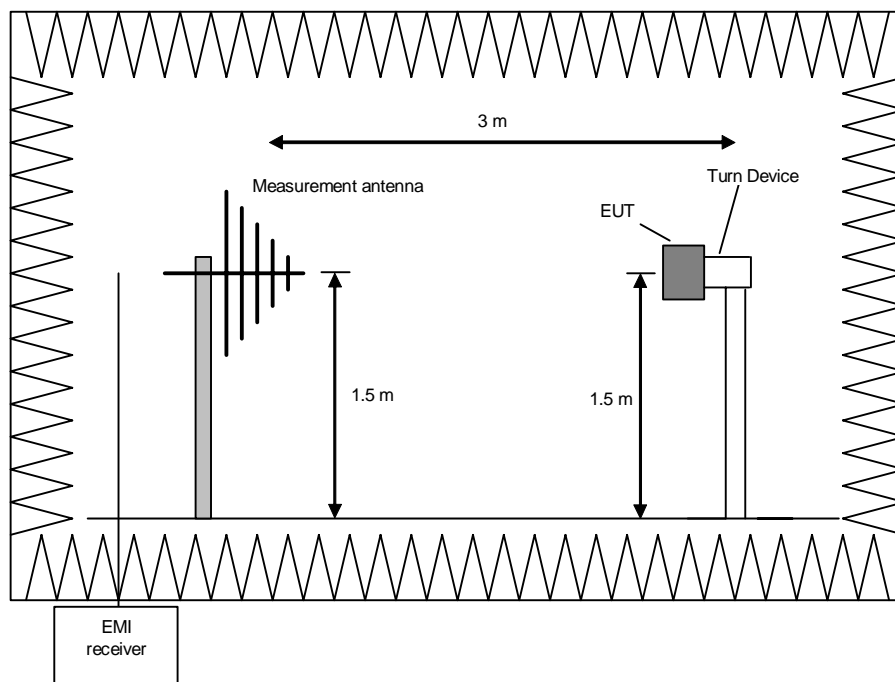

Procedure preliminary measurement:

Prescans were performed in the frequency range 30 MHz to 230 MHz and 230 MHz to 1 GHz.
The following procedure will be used:

1. Monitor the frequency range at horizontal polarisation and a EUT azimuth of 0 °.
2. Manipulate the system cables within the range to produce the maximum level of emission.
3. Rotate the EUT by 360 ° to maximize the detected signals.
4. Repeat 1) to 3) with the vertical polarisation of the measuring antenna.
5. Make a hardcopy of the spectrum.
6. Repeat 1) to 5) with the EUT raised by an angle of 30° (60°, 90°, 120° and 150°) according to 6.6.5.4 in [1].
7. Measure the frequency of the detected emissions with a lower span and resolution bandwidth to increase the accuracy and note the frequency value.

Final measurement (30 MHz to 1 GHz)

A final measurement on an open area test site will be performed on selected frequencies found in the preliminary measurement. During this test the EUT will be rotated in the range of 0 ° to 360 °, the measuring antenna will be set to horizontal and vertical polarisation and raised and lowered in the range from 1 m to 4 m to find the maximum level of emissions.

The resolution bandwidth of the EMI Receiver will be set to the following values:

Frequency range	Resolution bandwidth
30 MHz to 1 GHz	120 kHz

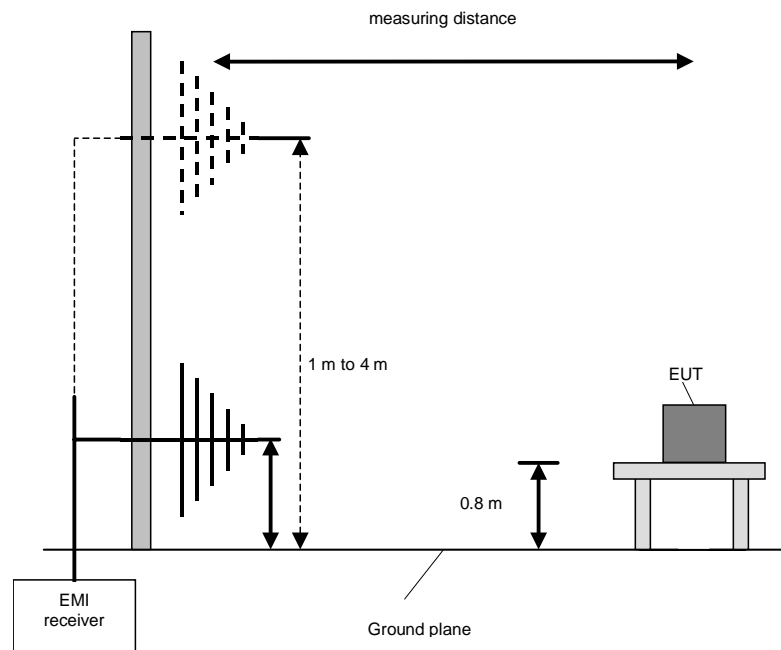

Procedure final measurement:

The following procedure will be used:

- 1) Measure on the selected frequencies at an antenna height of 1 m and a EUT azimuth of 23 °.
- 2) Move the antenna from 1 m to 4 m and note the maximum value at each frequency.
- 3) Rotate the EUT by 45 ° and repeat 2) until an azimuth of 337 ° is reached.
- 4) Repeat 1) to 3) for the other orthogonal antenna polarization.
- 5) Move the antenna and the turntable to the position where the maximum value is detected.
- 6) Measure while moving the antenna slowly +/- 1 m.
- 7) Set the antenna to the position where the maximum value is found.
- 8) Measure while moving the turntable +/- 45 °.
- 9) Set the turntable to the azimuth where the maximum value is found.
- 10) Measure with Final detector (QP and AV) and note the value.
- 11) Repeat 5) to 10) for each frequency.
- 12) Repeat 1) to 11) for each orthogonal axes of the EUT (because of EUT is a module and might be used in a handheld equipment application).

Preliminary and final measurement (1 GHz to 40 GHz)

This measurement will be performed in a fully anechoic chamber. Table top devices will set up on a non-conducting turn device on the height of 1.5m. The set-up of the Equipment under test will be in accordance to [1].

Preliminary measurement (1 GHz to 40 GHz)

The frequency range will be divided into different sub ranges depending of the frequency range of the used horn antenna. The spectrum analyser set to MAX Hold mode and a resolution bandwidth of 100 kHz. The measurement will be performed in horizontal and vertical polarisation of the measuring antenna and while rotating the EUT in its vertical axis in the range of 0 ° to 360 °. This measurement is repeated after raising the EUT in 30° steps according 6.6.5.4 in [1].

The resolution bandwidth of the EMI Receiver will be set to the following values:

Frequency range	Resolution bandwidth
1 GHz to 4 GHz	100 kHz
4 GHz to 12 GHz	100 kHz
12 GHz to 18 GHz	100 kHz
18 GHz to 25 / 26.5 GHz	100 kHz
26.5 GHz to 40 GHz	100 kHz

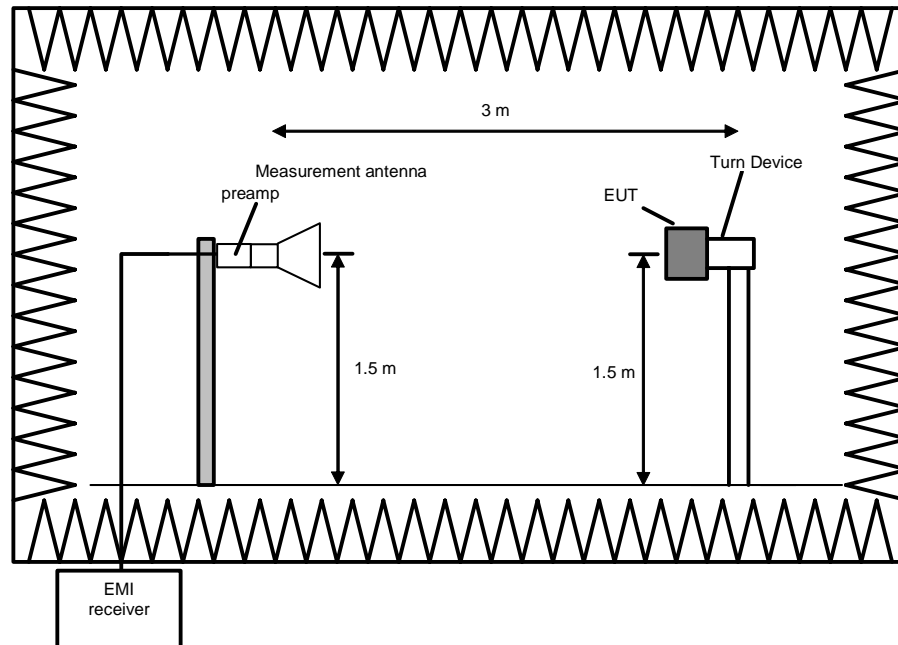

Procedure preliminary measurement:

Prescans were performed in the frequency range 1 to 40 GHz.

The following procedure will be used:

1. Monitor the frequency range at horizontal polarisation and a EUT azimuth of 0 °.
2. Rotate the EUT by 360° to maximize the detected signals.
3. Repeat 1) to 2) with the vertical polarisation of the measuring antenna.
4. Make a hardcopy of the spectrum.
5. Repeat 1) to 4) with the EUT raised by an angle of 30° (60°, 90°, 120° and 150°) according to 6.6.5.4 in [1].
6. Measure the frequency of the detected emissions with a lower span and resolution bandwidth to increase the accuracy and note the frequency value.
7. The measurement antenna polarisation, with the according EUT position (Turntable and Turn device) which produces the highest emission for each frequency will be used for the final measurement. The six closest values to the applicable limit will be used for the final measurement.

Final measurement (1 GHz to 25 GHz)

The frequency range will be divided into different sub ranges depending of the frequency range of the used horn antenna. The EMI Receiver set to peak and average mode and a resolution bandwidth of 1 MHz. The measurement will be performed by rotating the turntable through 0 to 360° in the worst-case EUT orientation which was obtained during the preliminary measurements.

The resolution bandwidth of the EMI Receiver will be set to the following values:

Frequency range	Resolution bandwidth
1 GHz to 4 GHz	1 MHz
4 GHz to 12 GHz	1 MHz
12 GHz to 18 GHz	1 MHz
18 GHz to 25 / 26.5 GHz	1 MHz
26.5 GHz to 40 GHz	1 MHz

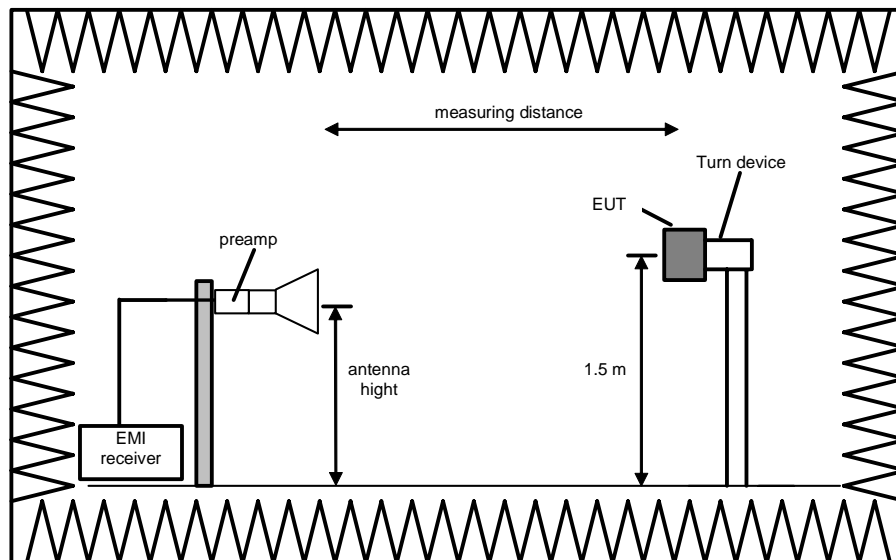

Procedure of measurement:

The measurements were performed in the frequency ranges 1 GHz to 4 GHz, 4 GHz to 12 GHz, 12 GHz to 18 GHz, 18 GHz to 25 GHz.

The following procedure will be used:

- 1) Set the turntable and the turn device to obtain the worst-case emission for the first frequency identified in the preliminary measurements.
- 2) Set the measurement antenna polarisation to the orientation with the highest emission for the first frequency identified in the preliminary measurements.
- 3) Set the spectrum analyser to EMI mode with peak and average detector activated.
- 4) Rotate the turntable from 0° to 360° to find the EUT angle that produces the highest emissions.
- 5) Note the highest displayed peak and average values
- 6) Repeat the steps 1) to 5) for each frequency detected during the preliminary measurements.

5.6.5 Test results (radiated emissions)

5.6.5.1 Preliminary radiated emission measurement

Ambient temperature	21 °C	Relative humidity	51 %
---------------------	-------	-------------------	------

- Position of EUT:** The EUT was set-up on a non-conducting table of a height of 0.8 m or an EUT turn device of a height of 1.5 m. The distance between EUT and antenna was 3 m.
- Cable guide:** For detail information of test set-up and the cable guide refer to the pictures in Testsetup Foto annex.
- Test record:** All results are shown in the following.
- Supply voltage:** During all measurements the host of the EUT was powered with 13 V DC via an laboratory power supply.
- Remark:** Document [1] states in 11.12.2.1, that in case of conducted measurements, additional radiated cabinet emission measurements must be performed. The measurements were performed at the worst case modulations for each frequency range.

No emissions up to 20 dB to the limit were found below 30 MHz, therefore only the plots of the worst case emissions are submitted for every frequency range above 30 GHz in the preliminary results.

The Emissions below 1 GHz were equal for all antenna ports, transmit frequencies, modulation schemes and data rates. Therefore only the results of an exemplary test case are submitted below.

All modes (UGKZ7A1001A & UGXZEX304A module including simultaneous transmission)

All modes.Rtf: Spurious emissions from 30 MHz to 4 GHz (all operation modes):

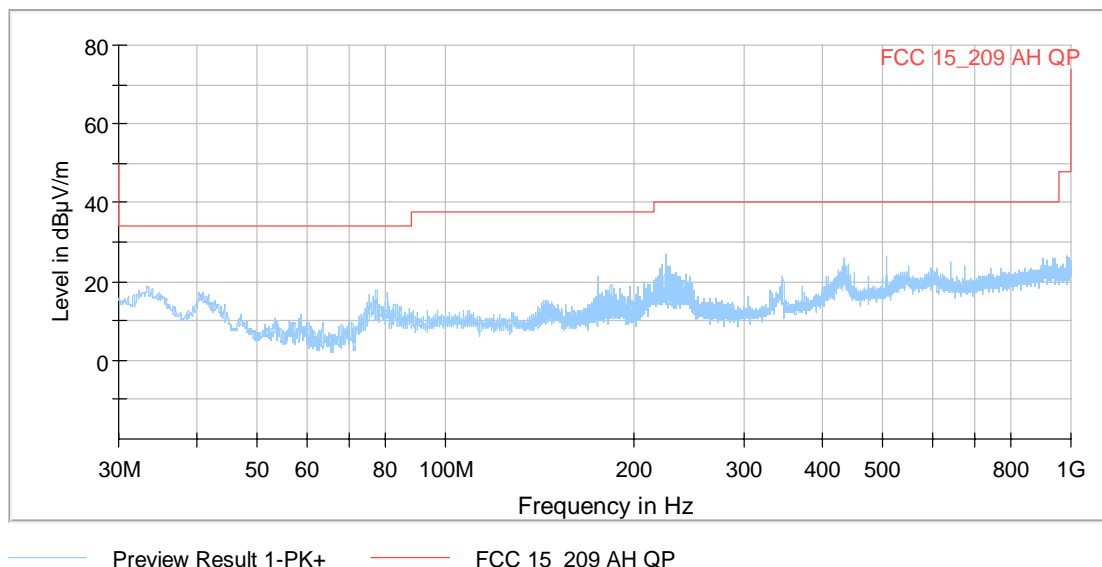

UGKZ7A1001A (BT/WLAN combi module) with WLAN mode active

162097 1-4 GHz ch6.Rtf: Spurious emissions from 1 GHz to 4 GHz (operation mode 2):

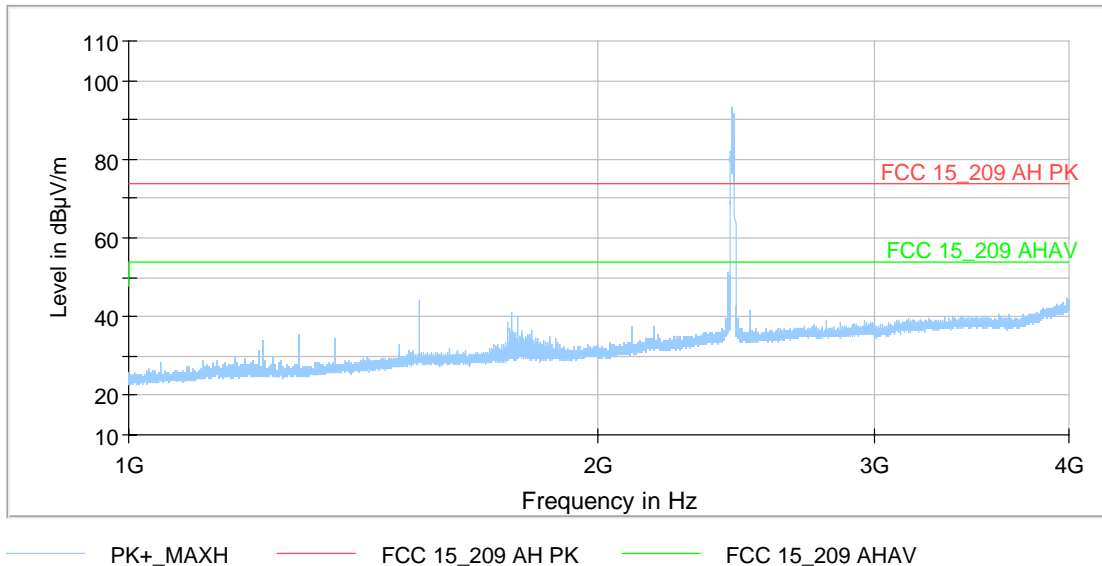

162097 4-12 GHz ch6.Rtf: Spurious emissions from 4 GHz to 12 GHz (operation mode 2):

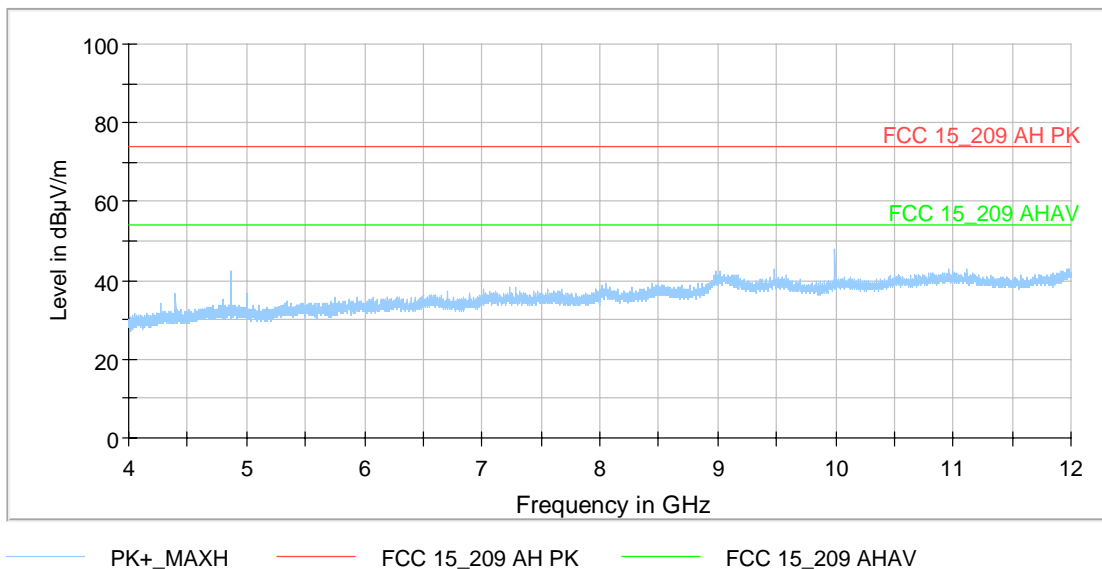

162097 12-18 GHz ch6.Rtf: Spurious emissions from 12 to 18 GHz (operation mode 2):

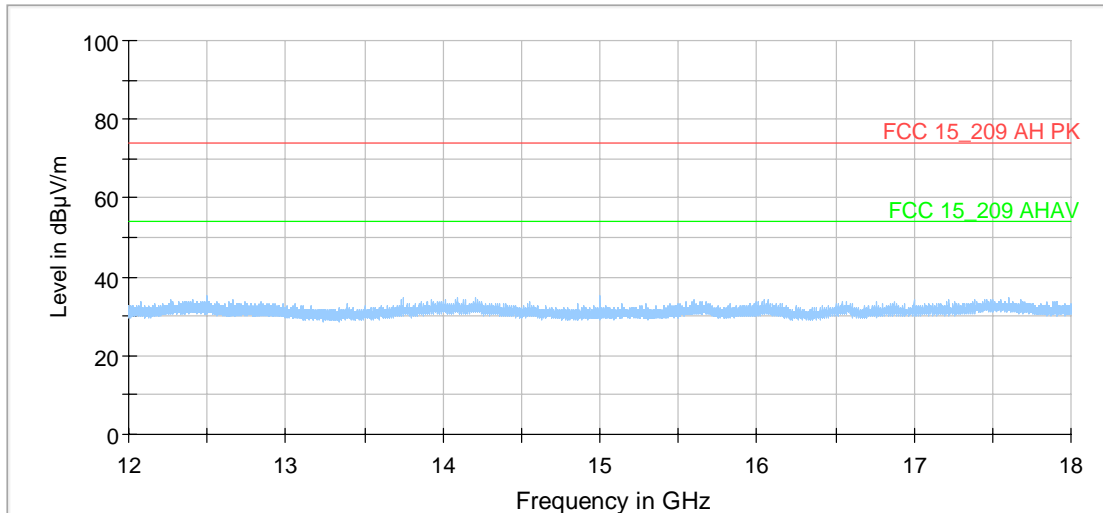

PK+_MAXH FCC 15_209 AH PK FCC 15_209 AHAV

162097 18-26,5 GHz ch 6.Rtf: Spurious emissions from 18 – 25 GHz (operation mode 2):

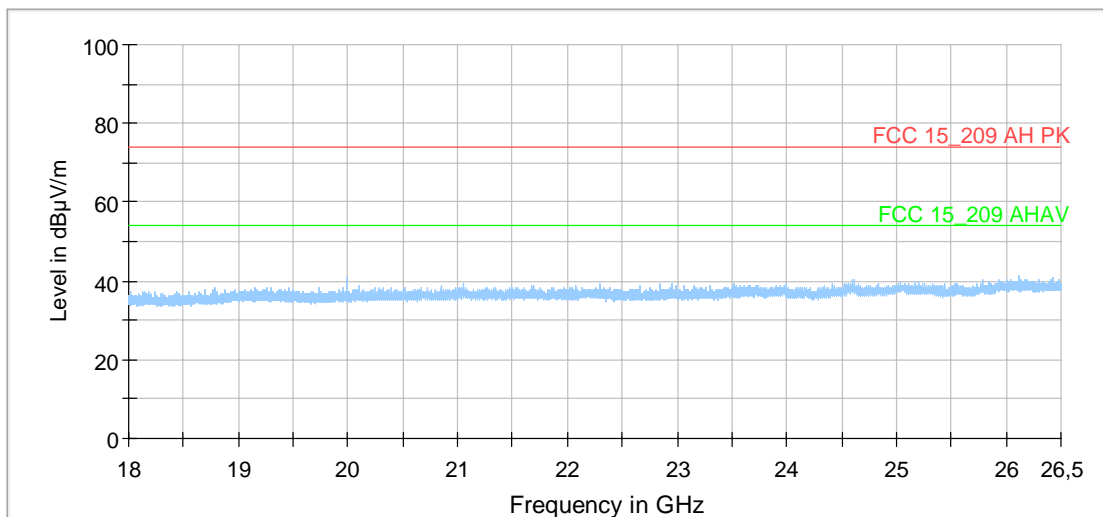

PK+_MAXH FCC 15_209 AH PK FCC 15_209 AHAV

UGKZ7A1001A (BT/WLAN combi module) with Bluetooth mode active

162097 1-4 GHz ch78.Rtf: Spurious emissions from 1 GHz to 4 GHz (operation mode 12):

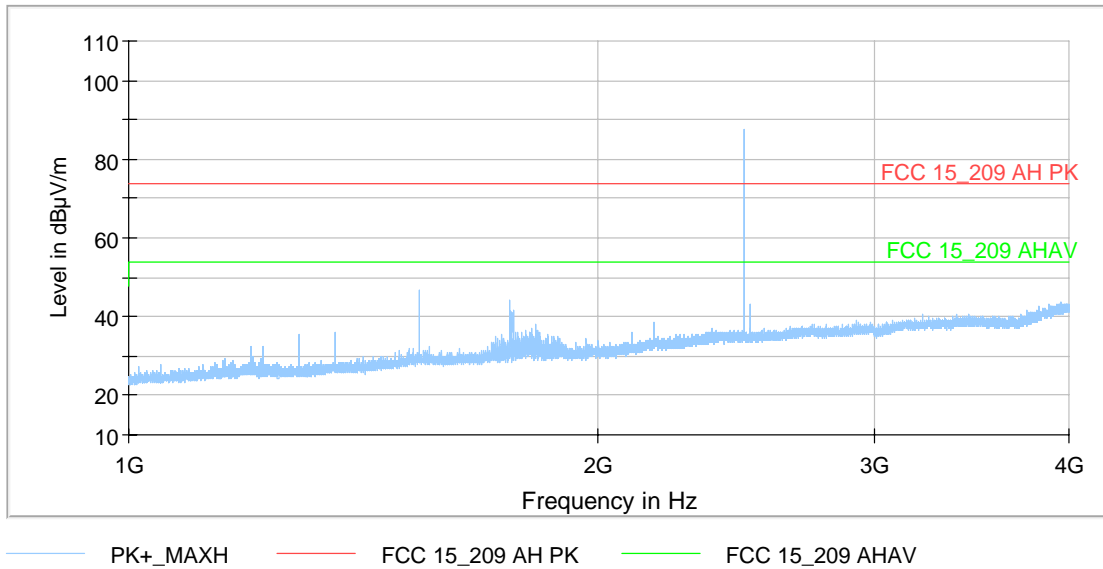

162097 4-12 GHz Low.Rtf: Spurious emissions from 4 GHz to 12 GHz (operation mode 10):

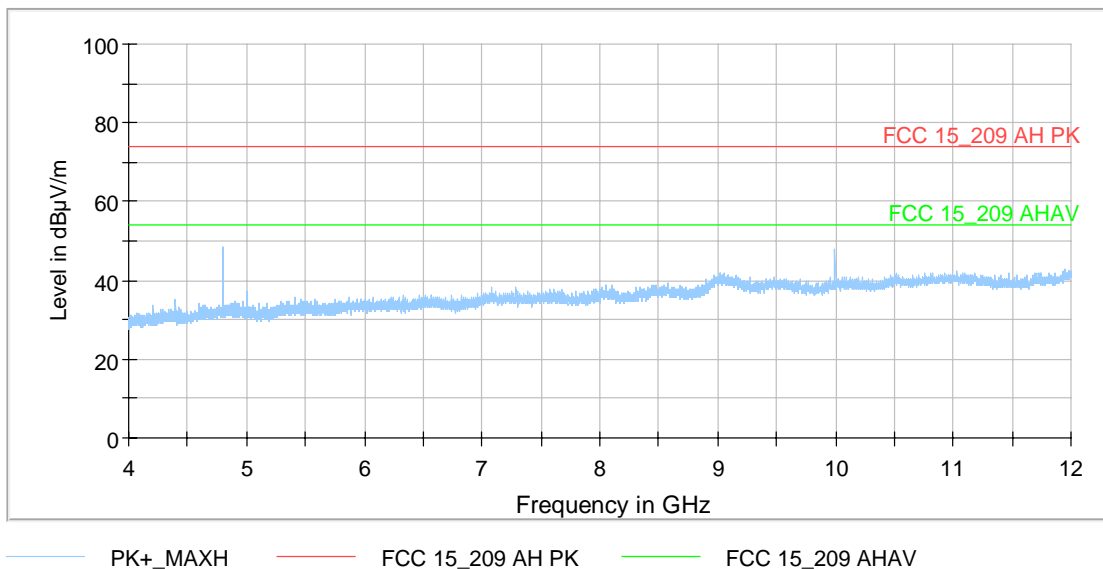

162097 12-18 GHz ch78.Rtf: Spurious emissions from 12 to 18 GHz (operation mode 12):

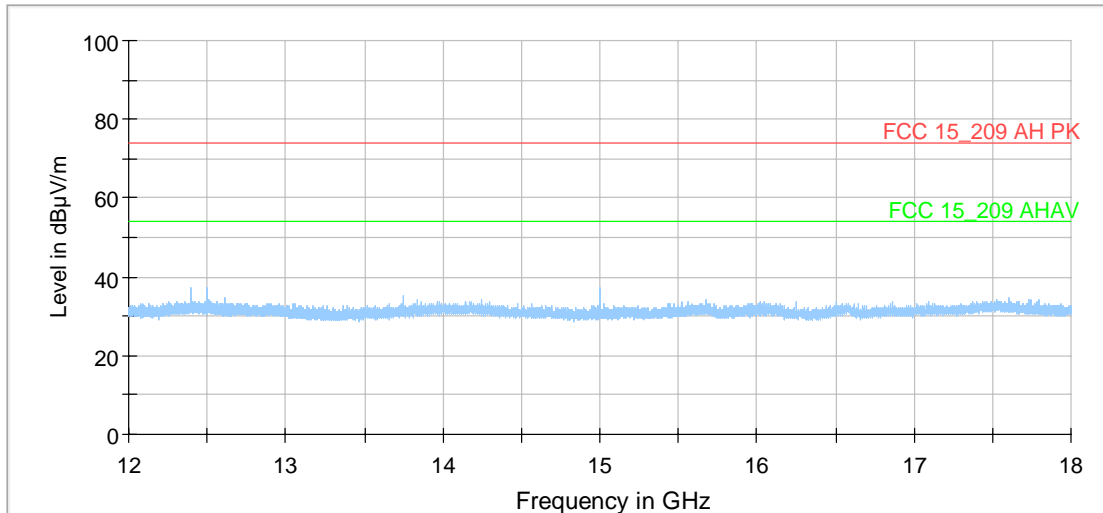

— PK+_MAXH — FCC 15_209 AH PK — FCC 15_209 AHAV

EMI Report 18-26,5 GHz.Rtf: Spurious emissions from 18 – 25 GHz (operation mode 11):

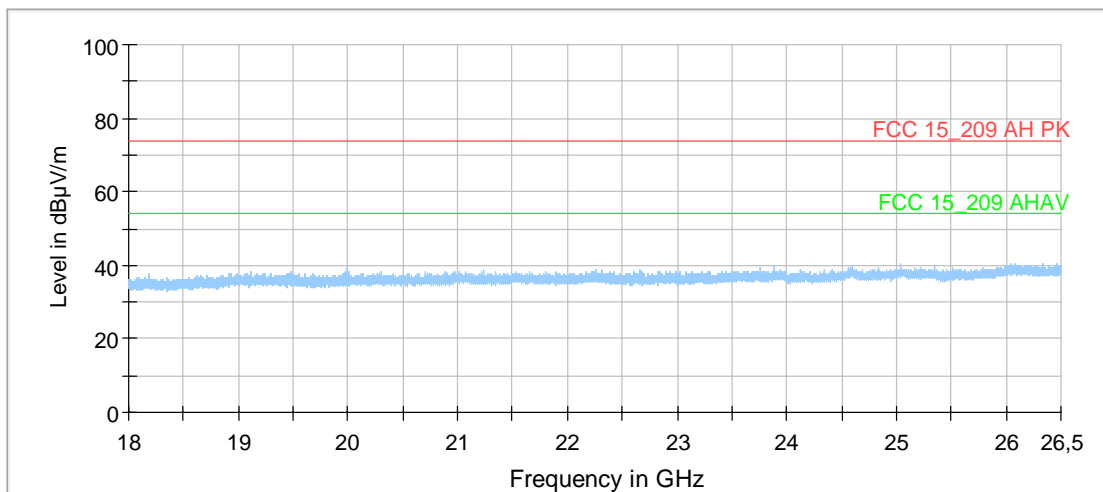

— Preview Result 1-PK+ * Critical_Freqs PK+ Final_Result PK+ — FCC 15_209 AH PK
— FCC 15_209 AHAV ◆ Final_Result CAV

UGKZ7A1001A (BT/WLAN combi module) with Bluetooth mode active

162097 1-4 GHz ch0.Rtf: Spurious emissions from 1 GHz to 4 GHz (operation mode 19):

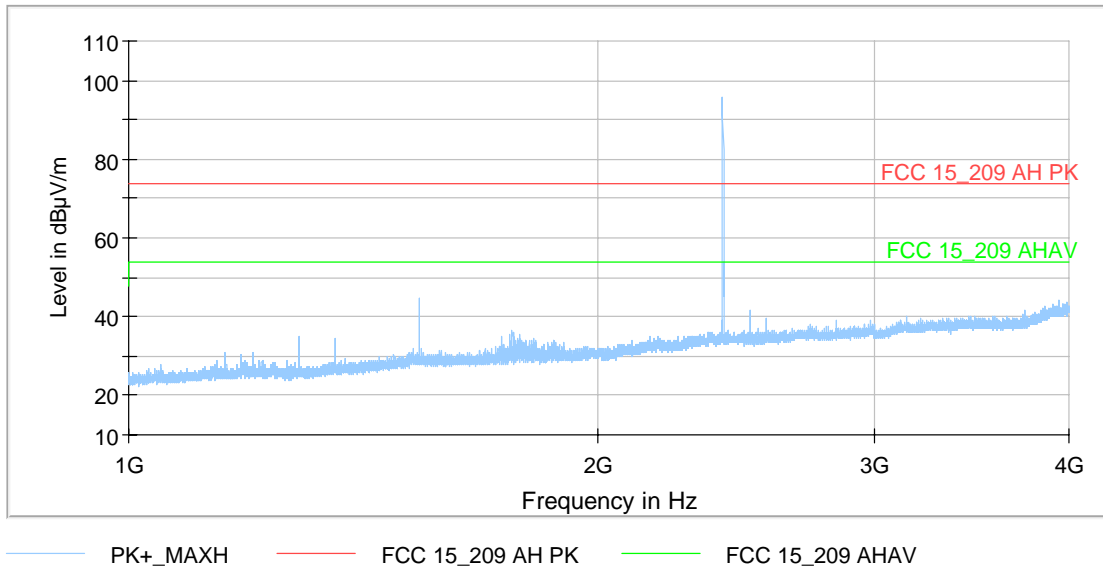

162097 4-12 GHz ch78.Rtf: Spurious emissions from 4 GHz to 12 GHz (operation mode 21):

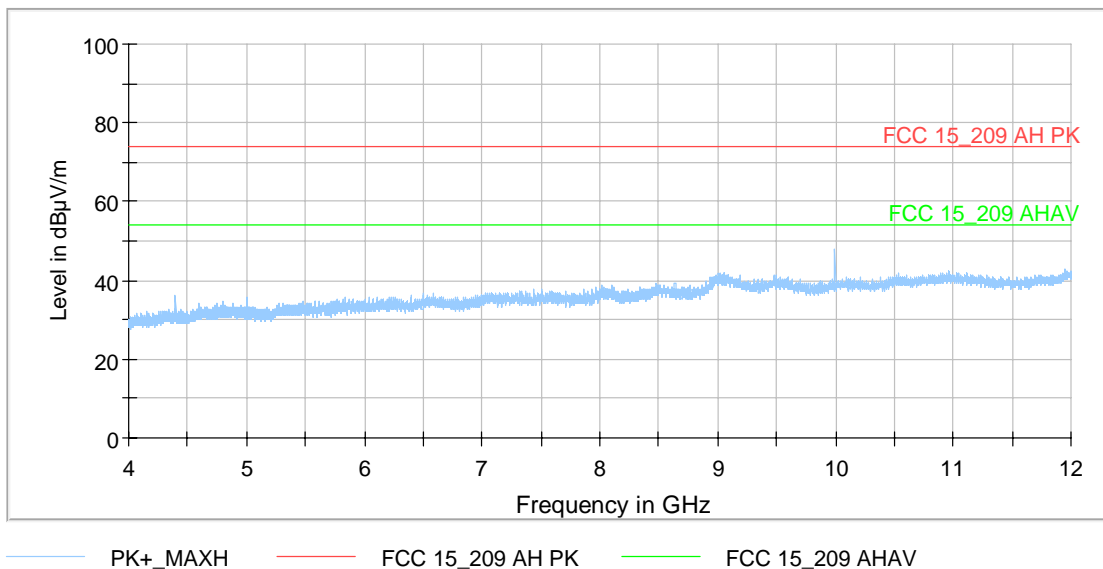

162097 12-18 GHz ch0.Rtf: Spurious emissions from 12 to 18 GHz (operation mode 19):

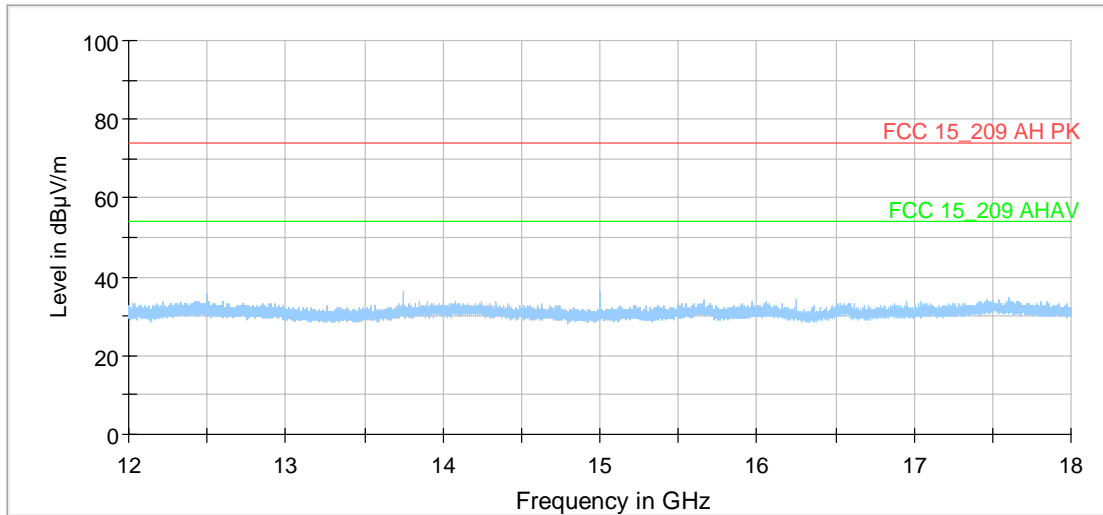

— PK+_MAXH — FCC 15_209 AH PK — FCC 15_209 AHAV

162097 18-26,5 GHz ch 39.Rtf: Spurious emissions from 18 – 25 GHz (operation mode 20):

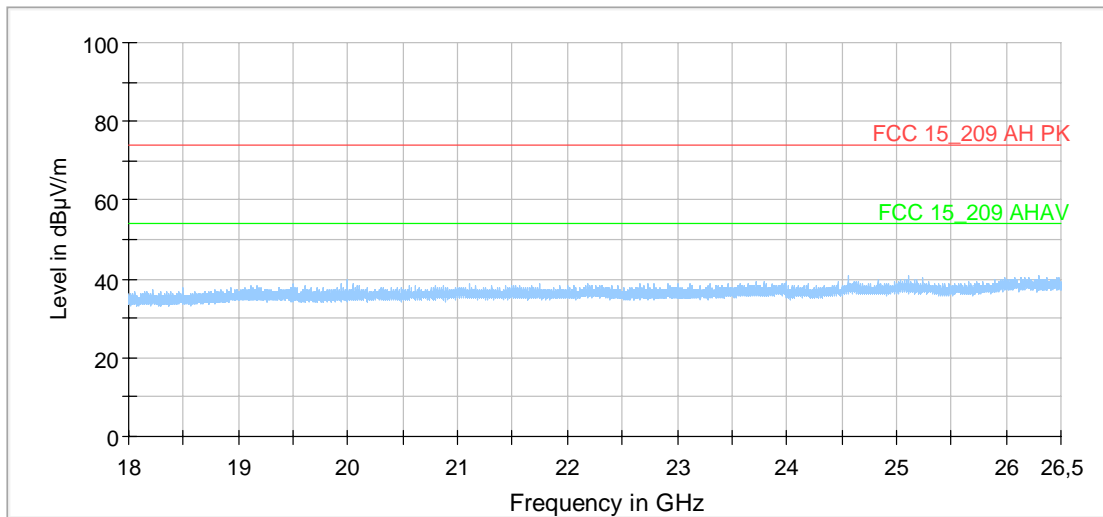

— PK+_MAXH — FCC 15_209 AH PK — FCC 15_209 AHAV

TEST EQUIPMENT USED FOR THE TEST:
5, 8, 29, 31 -

5.6.5.2 Final radiated emission measurement (9 kHz to 1 GHz)

Ambient temperature	22 °C	Relative humidity	55 %
---------------------	-------	-------------------	------

- Position of EUT: The EUT was set-up on table with the height of 0.8 m.
- Cable guide: For detail information of test set-up and the cable guide refer to the pictures in test setup photos.
- Test record: All results are shown in the following.
- Supply voltage: During all measurements the host of the EUT was powered with 13 V DC via a laboratory power supply.
- Resolution bandwidth: For all measurements a resolution bandwidth of 100 kHz was used.
- Additional information: All emissions below 30 MHz were more than 20 dB to the limit line, therefore no results are submitted below.

The correction factor is calculated as Antenna Factor [dB] + Cable Attenuation [dB] - Amplifier Gain[dB]

The result Peak/Average is the result of Reading [dB μ V/m] – Correction factor [dB]

162097_30MHz-1GHzFF_allModes.rtf: Spurious emissions from 30 MHz to 1 GHz (all operation modes)

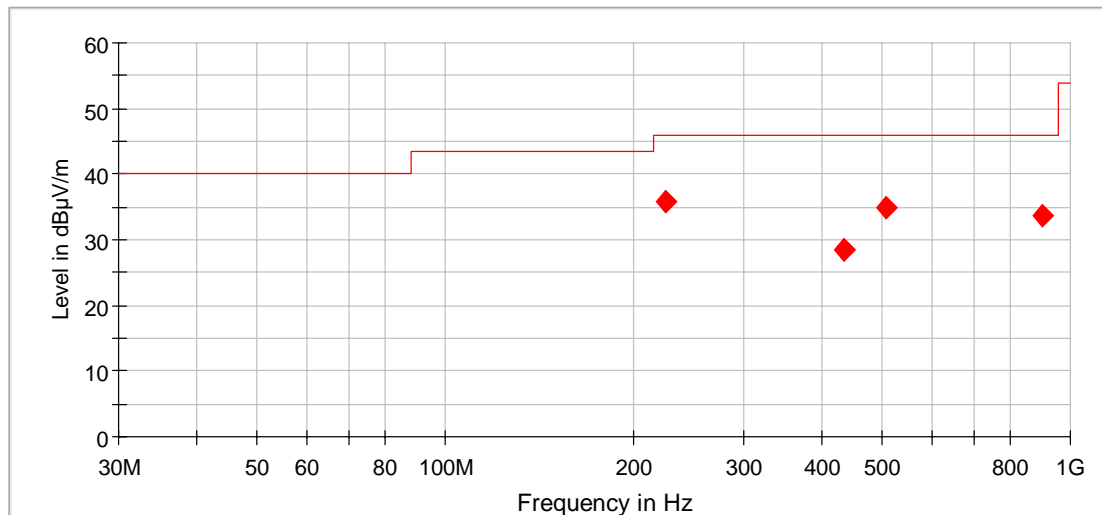

— FCC 15.109 B F QP ◆ Final_Result QPK

Final_Result

Frequency [MHz]	QuasiPeak [dB μ V/m]	Limit [dB μ V/m]	Margin [dB]	Meas. Time [ms]	Bandwidth [kHz]	Height [cm]	Pol	Azimuth [deg]	Corr. [dB]
224.970000	35.79	46.00	10.21	1000.0	120.000	123.0	H	0.0	19.6
435.298333	28.58	46.00	17.42	1000.0	120.000	109.0	V	266.0	26.3
435.729444	28.48	46.00	17.52	1000.0	120.000	114.0	V	253.0	26.3
507.832778	35.00	46.00	11.00	1000.0	120.000	155.0	H	218.0	28.0
899.874444	33.61	46.00	12.39	1000.0	120.000	376.0	H	211.0	34.5
Measurement uncertainty					+2.2 dB / -3.6 dB				

5.6.5.3 Final radiated emission measurement (1 GHz to 25 GHz)

Ambient temperature	22 °C	Relative humidity	55 %
---------------------	-------	-------------------	------

- Position of EUT: The EUT was set-up on an EUT turn device of a height of 1.5 m. The distance between EUT and antenna was 3 m.
- Cable guide: For detail information of test set-up and the cable guide refer to the pictures in test setup photos.
- Test record: All results are shown in the following.
- Supply voltage: During all measurements the host of the EUT was powered with 13 V DC via alaboratory power supply.
- Resolution bandwidth: For all measurements a resolution bandwidth of 1 MHz was used.
- Additional information: For simplification all values were compared to the restricted band limits.

UGKZ7A1001A (BT/WLAN combi module) with WLAN mode active

Since the 802.11b mode was found to be the worst case mode during the conducted measurements, only these tests were performed as radiated measurements.

Transmitter operates at the lower end of the assigned frequency band (operation mode 1)

Frequency (MHz)	MaxPeak (dB μ V/m)	CAverage (dB μ V/m)	Limit (dB μ V/m)	Margin (dB)	Pol	Azimuth (deg)	Elevation (deg)	Corr. (dB)	Result
1535.991117	52.94	---	74.00	21.06	V	241.0	150.0	28.7	Passed
1535.991117	---	41.90	54.00	12.10	V	241.0	150.0	28.7	Passed
2412.584500	---	90.91	54.00	-	H	271.0	120.0	33.6	Fund.
2412.584500	93.40	---	74.00	-	H	271.0	120.0	33.6	Fund.
2499.968183	59.48	---	74.00	14.52	H	72.0	30.0	33.4	Passed
2499.968183	---	47.28	54.00	6.72	H	72.0	30.0	33.4	Passed
4823.958800	47.78	---	74.00	26.22	V	237.0	120.0	-1.6	Passed
4823.958800	---	42.67	54.00	11.33	V	237.0	120.0	-1.6	Passed
4999.916200	43.41	---	74.00	30.59	V	230.0	150.0	-1.6	Passed
4999.916200	---	34.33	54.00	19.67	V	230.0	150.0	-1.6	Passed
9999.833195	---	48.45	54.00	5.55	V	49.0	60.0	7.3	Passed
9999.833195	53.58	---	74.00	20.42	V	49.0	60.0	7.3	Passed
19999.650000	---	38.54	54.00	15.46	V	68.0	0.0	6.9	Passed
19999.650000	47.34	---	74.00	26.66	V	68.0	0.0	6.9	Passed
Measurement uncertainty			+2.2 dB / -3.6 dB						

Transmitter operates at the middle of the assigned frequency band (operation mode 2)

Frequency (MHz)	MaxPeak (dB μ V/m)	CAverage (dB μ V/m)	Limit (dB μ V/m)	Margin (dB)	Pol	Azimuth (deg)	Elevation (deg)	Corr. (dB)	Result
1535.990417	---	42.39	54.00	11.61	V	133.0	60.0	28.7	Passed
1535.990417	53.70	---	74.00	20.30	V	133.0	60.0	28.7	Passed
1760.553183	---	40.97	54.00	13.03	V	72.0	30.0	29.7	Passed
1760.553183	54.22	---	74.00	19.78	V	72.0	30.0	29.7	Passed
2435.680983	---	93.31	54.00	-	H	90.0	30.0	33.6	Fund.
2435.680983	95.56	---	74.00	-	H	90.0	30.0	33.6	Fund.
2499.951300	---	47.40	54.00	6.60	H	105.0	30.0	33.4	Passed
2499.951300	59.36	---	74.00	14.64	H	105.0	30.0	33.4	Passed
4873.968605	---	41.09	54.00	12.91	V	243.0	150.0	-1.5	Passed
4873.968605	46.68	---	74.00	27.32	V	243.0	150.0	-1.5	Passed
9999.838795	54.34	---	74.00	19.66	V	50.0	59.0	7.3	Passed
9999.838795	---	48.53	54.00	5.47	V	50.0	59.0	7.3	Passed
19999.625000	---	39.73	54.00	14.27	V	318.0	120.0	6.9	Passed
19999.625000	47.96	---	74.00	26.04	V	318.0	120.0	6.9	Passed
Measurement uncertainty			+2.2 dB / -3.6 dB						

Transmitter operates at the middle of the assigned frequency band (operation mode 3)

Frequency (MHz)	MaxPeak (dB μ V/m)	CAverage (dB μ V/m)	Limit (dB μ V/m)	Margin (dB)	Pol	Azimuth (deg)	Elevation (deg)	Corr. (dB)	Result
1536.000217	---	43.54	54.00	10.46	V	112.0	60.0	28.7	Passed
1536.000217	54.09	---	74.00	19.91	V	112.0	60.0	28.7	Passed
2098.850083	---	43.46	54.00	10.54	H	142.0	30.0	31.9	Passed
2098.850083	56.44	---	74.00	17.56	H	142.0	30.0	31.9	Passed
2459.650000	---	91.09	54.00	-	V	142.0	59.0	33.8	Fund.
2459.650000	93.40	---	74.00	-	V	142.0	59.0	33.8	Fund.
2499.950800	---	47.34	54.00	6.66	H	67.0	30.0	33.4	Passed
2499.950800	59.42	---	74.00	14.58	H	67.0	30.0	33.4	Passed
4923.964400	47.35	---	74.00	26.65	V	236.0	120.0	-1.7	Passed
4923.964400	---	42.39	54.00	11.61	V	236.0	120.0	-1.7	Passed
9999.832995	---	48.14	54.00	5.86	V	51.0	60.0	7.3	Passed
9999.832995	53.84	---	74.00	20.16	V	51.0	60.0	7.3	Passed
19999.665000	---	37.93	54.00	16.07	V	262.0	150.0	6.9	Passed
19999.665000	47.29	---	74.00	26.71	V	262.0	150.0	6.9	Passed
Measurement uncertainty			+2.2 dB / -3.6 dB						

UGKZ7A1001A (BT/WLAN combi module) with Bluetooth mode active

Since the DH5 mode was found to be the worst case mode during the conducted measurements, only these tests were performed as radiated measurements.

Transmitter operates at the lower end of the assigned frequency band (operation mode 10)

Frequency (MHz)	MaxPeak (dB μ V/m)	CAverage (dB μ V/m)	Limit (dB μ V/m)	Margin (dB)	Pol	Azimuth (deg)	Elevation (deg)	Corr. (dB)	Result
1535.991817	---	43.76	54.00	10.24	H	50.0	0.0	28.7	Passed
1535.991817	54.33	---	74.00	19.67	H	50.0	0.0	28.7	Passed
2402.029400	---	84.37	54.00	-	H	263.0	120.0	33.5	Fund.
2402.029400	87.25	---	74.00	-	H	263.0	120.0	33.5	Fund.
2499.962000	---	47.35	54.00	6.65	H	66.0	29.0	33.4	Passed
2499.962000	59.02	---	74.00	14.98	H	66.0	29.0	33.4	Passed
4803.958405	51.02	---	74.00	22.98	V	250.0	120.0	-1.7	Passed
4803.958405	---	46.44	54.00	7.56	V	250.0	120.0	-1.7	Passed
4999.930700	---	35.46	54.00	18.54	V	303.0	90.0	-1.6	Passed
4999.930700	44.37	---	74.00	29.63	V	303.0	90.0	-1.6	Passed
9999.830895	53.74	---	74.00	20.26	V	49.0	59.0	7.3	Passed
9999.830895	---	47.89	54.00	6.11	V	49.0	59.0	7.3	Passed
19999.650000	---	38.61	54.00	15.39	V	68.0	0.0	6.9	Passed
19999.650000	47.64	---	74.00	26.36	V	68.0	0.0	6.9	Passed
Measurement uncertainty			+2.2 dB / -3.6 dB						

Transmitter operates at the middle of the assigned frequency band (operation mode 11)

Frequency (MHz)	MaxPeak (dB μ V/m)	CAverage (dB μ V/m)	Limit (dB μ V/m)	Margin (dB)	Pol	Azimuth (deg)	Elevation (deg)	Corr. (dB)	Result
1535.993617	53.18	---	74.00	20.82	H	85.0	30.0	28.7	Passed
1535.993617	---	41.98	54.00	12.02	H	85.0	30.0	28.7	Passed
2441.016700	94.27	---	74.00	-	V	290.0	150.0	33.7	Fund.
2441.016700	---	91.45	54.00	-	V	290.0	150.0	33.7	Fund.
2499.958500	---	46.93	54.00	7.07	H	65.0	30.0	33.4	Passed
2499.958500	59.65	---	74.00	14.35	H	65.0	30.0	33.4	Passed
9999.831995	---	46.69	54.00	7.31	V	47.0	60.0	7.3	Passed
9999.831995	52.92	---	74.00	21.08	V	47.0	60.0	7.3	Passed
19999.675000	---	39.28	54.00	14.72	V	67.0	0.0	6.9	Passed
19999.675000	47.91	---	74.00	26.09	V	67.0	0.0	6.9	Passed
24555.445000	---	35.00	54.00	19.00	V	206.0	90.0	7.7	Passed
24555.445000	47.33	---	74.00	26.67	V	206.0	90.0	7.7	Passed
Measurement uncertainty			+2.2 dB / -3.6 dB						

Transmitter operates at the upper end of the assigned frequency band (operation mode 12)

Frequency (MHz)	MaxPeak (dB μ V/m)	CAverage (dB μ V/m)	Limit (dB μ V/m)	Margin (dB)	Pol	Azimuth (deg)	Elevation (deg)	Corr. (dB)	Result
1535.987517	---	42.68	54.00	11.32	V	114.0	60.0	28.7	Passed
1535.987517	54.19	---	74.00	19.81	V	114.0	60.0	28.7	Passed
1754.959200	---	41.00	54.00	13.00	V	246.0	150.0	29.6	Passed
1754.959200	58.10	---	74.00	15.90	V	246.0	150.0	29.6	Passed
1765.314600	---	41.04	54.00	12.96	V	246.0	150.0	29.7	Passed
1765.314600	54.83	---	74.00	19.17	V	246.0	150.0	29.7	Passed
2479.650000	---	83.67	54.00	-	V	234.0	150.0	33.6	Fund.
2479.650000	88.42	---	74.00	-	V	234.0	150.0	33.6	Fund.
2499.957900	---	47.42	54.00	6.58	H	104.0	30.0	33.4	Passed
2499.957900	59.65	---	74.00	14.35	H	104.0	30.0	33.4	Passed
4959.902200	---	48.24	54.00	5.76	V	244.0	150.0	-1.5	Passed
4959.902200	52.46	---	74.00	21.54	V	244.0	150.0	-1.5	Passed
9999.845100	52.97	---	74.00	21.03	V	52.0	60.0	7.3	Passed
9999.845100	---	47.16	54.00	6.84	V	52.0	60.0	7.3	Passed
Measurement uncertainty			+2.2 dB / -3.6 dB						

UGXZEX304A (BT only module)

Since the DH5 mode was found to be the worst case mode during the conducted measurements, only these tests were performed as radiated measurements.

Transmitter operates at the lower end of the assigned frequency band (operation mode 19)

Frequency (MHz)	MaxPeak (dB μ V/m)	CAverage (dB μ V/m)	Limit (dB μ V/m)	Margin (dB)	Pol	Azimuth (deg)	Elevation (deg)	Corr. (dB)	Result
1353.950083	---	38.93	54.00	15.07	H	213.0	30.0	27.3	Passed
1353.950083	50.88	---	74.00	23.12	H	213.0	30.0	27.3	Passed
1535.997717	---	42.05	54.00	11.95	H	66.0	0.0	28.7	Passed
1535.997717	53.73	---	74.00	20.27	H	66.0	0.0	28.7	Passed
2402.090400	---	93.86	54.00	-	V	306.0	150.0	33.5	Fund.
2402.090400	96.77	---	74.00	-	V	306.0	150.0	33.5	Fund.
2499.966600	---	47.18	54.00	6.82	H	66.0	30.0	33.4	Passed
2499.966600	60.16	---	74.00	13.84	H	66.0	30.0	33.4	Passed
2558.068517	---	46.87	54.00	7.13	V	294.0	150.0	33.8	Passed
2558.068517	58.87	---	74.00	15.13	V	294.0	150.0	33.8	Passed
9999.841100	---	48.28	54.00	5.72	V	51.0	60.0	7.3	Passed
9999.841100	53.68	---	74.00	20.32	V	51.0	60.0	7.3	Passed
19999.650000	---	39.06	54.00	14.94	V	294.0	150.0	6.9	Passed
19999.650000	48.06	---	74.00	25.94	V	294.0	150.0	6.9	Passed
Measurement uncertainty			+2.2 dB / -3.6 dB						

Transmitter operates at the middle of the assigned frequency band (operation mode 20)

Frequency (MHz)	MaxPeak (dBμV/m)	CAverage (dBμV/m)	Limit (dBμV/m)	Margin (dB)	Pol	Azimuth (deg)	Elevation (deg)	Corr. (dB)	Result
1535.993617	53.18	---	74.00	20.82	H	85.0	30.0	28.7	Passed
1535.993617	---	41.98	54.00	12.02	H	85.0	30.0	28.7	Passed
2441.016700	94.27	---	74.00	-	V	290.0	150.0	33.7	Fund.
2441.016700	---	91.45	54.00	-	V	290.0	150.0	33.7	Fund.
2499.958500	---	46.93	54.00	7.07	H	65.0	30.0	33.4	Passed
2499.958500	59.65	---	74.00	14.35	H	65.0	30.0	33.4	Passed
9999.831995	---	46.69	54.00	7.31	V	47.0	60.0	7.3	Passed
9999.831995	52.92	---	74.00	21.08	V	47.0	60.0	7.3	Passed
19999.675000	---	39.28	54.00	14.72	V	67.0	0.0	6.9	Passed
19999.675000	47.91	---	74.00	26.09	V	67.0	0.0	6.9	Passed
24555.445000	---	35.00	54.00	19.00	V	206.0	90.0	7.7	Passed
24555.445000	47.33	---	74.00	26.67	V	206.0	90.0	7.7	Passed
Measurement uncertainty			+2.2 dB / -3.6 dB						

Transmitter operates at the upper end of the assigned frequency band (operation mode 21)

Frequency (MHz)	MaxPeak (dBμV/m)	CAverage (dBμV/m)	Limit (dBμV/m)	Margin (dB)	Pol	Azimuth (deg)	Elevation (deg)	Corr. (dB)	Result
1535.996317	---	41.61	54.00	12.39	H	307.0	0.0	28.7	Passed
1535.996317	53.49	---	74.00	20.51	H	307.0	0.0	28.7	Passed
2323.999783	---	45.80	54.00	8.20	V	299.0	150.0	33.1	Passed
2323.999783	58.04	---	74.00	15.96	V	299.0	150.0	33.1	Passed
2479.870000	---	88.51	54.00	-	V	69.0	29.0	33.6	Fund.
2479.870000	91.79	---	74.00	-	V	69.0	29.0	33.6	Fund.
2499.956000	---	46.83	54.00	7.17	H	73.0	0.0	33.4	Passed
2499.956000	59.33	---	74.00	14.67	H	73.0	0.0	33.4	Passed
9999.846200	---	48.53	54.00	5.47	V	50.0	60.0	7.3	Passed
9999.846200	53.72	---	74.00	20.28	V	50.0	60.0	7.3	Passed
12499.790000	---	33.38	54.00	20.62	V	78.0	60.0	12.1	Passed
12499.790000	44.00	---	74.00	30.00	V	78.0	60.0	12.1	Passed
16249.740000	---	33.84	54.00	20.16	V	78.0	60.0	10.6	Passed
16249.740000	43.59	---	74.00	30.41	V	78.0	60.0	10.6	Passed
19999.650000	---	38.84	54.00	15.16	V	300.0	90.0	6.9	Passed
19999.650000	47.94	---	74.00	26.06	V	300.0	90.0	6.9	Passed
Measurement uncertainty			+2.2 dB / -3.6 dB						

5.6.5.4 Band-edge-compliance (radiated)

Only the plot of the worst case emission is submitted below

UGKZ7A1001A (BT/WLAN combi module) with WLAN mode active

162097 UpperBandEdge GHz ch11.rtf: Spurious emissions from 30 MHz to 1 GHz (operation mode 1):

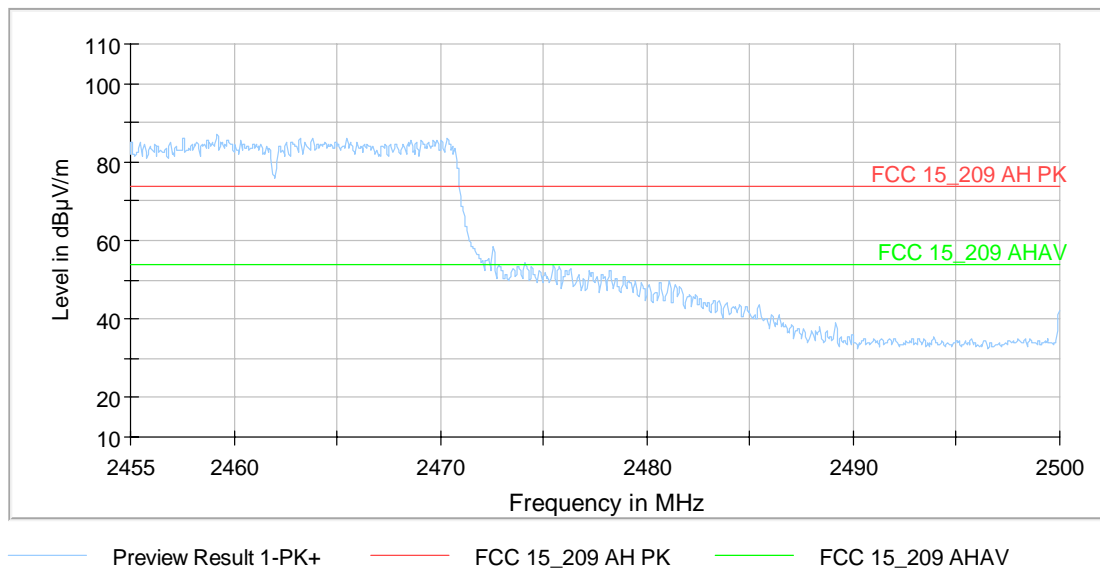

Transmitter operates at the lower end of the assigned frequency band (operation mode 7)

Frequency (MHz)	MaxPeak (dBµV/m)	CAverage (dBµV/m)	Limit (dBµV/m)	Margin (dB)	Pol	Azimuth (deg)	Elevation (deg)	Corr. (dB)	Result
2388.300000	57.80	---	74.00	16.20	V	101.0	0.0	33.5	Passed
2388.300000	---	46.26	54.00	7.74	V	101.0	0.0	33.5	Passed
2390.060000	59.46	---	74.00	14.54	V	301.0	120.0	33.5	Passed
2390.060000	---	46.57	54.00	7.43	V	301.0	120.0	33.5	Passed
Measurement uncertainty			+2.2 dB / -3.6 dB						

Transmitter operates at the upper end of the assigned frequency band (operation mode 9)

Frequency (MHz)	MaxPeak (dB μ V/m)	CAverage (dB μ V/m)	Limit (dB μ V/m)	Margin (dB)	Pol	Azimuth (deg)	Elevation (deg)	Corr. (dB)	Result
2483.780000	---	48.39	54.00	5.61	V	233.0	150.0	33.6	Passed
2483.780000	65.43	---	74.00	8.57	V	233.0	150.0	33.6	Passed
2483.912000	---	47.76	54.00	6.24	V	258.0	150.0	33.6	Passed
2483.912000	61.98	---	74.00	12.02	V	258.0	150.0	33.6	Passed
2485.512500	---	47.57	54.00	6.43	V	237.0	150.0	33.6	Passed
2485.512500	61.75	---	74.00	12.25	V	237.0	150.0	33.6	Passed
Measurement uncertainty			+2.2 dB / -3.6 dB						

UGKZ7A1001A (BT/WLAN combi module) with Bluetooth mode active

162097 UpperBandEdge GHz ch78.rtf: Spurious emissions from 30 MHz to 1 GHz (operation mode 18):

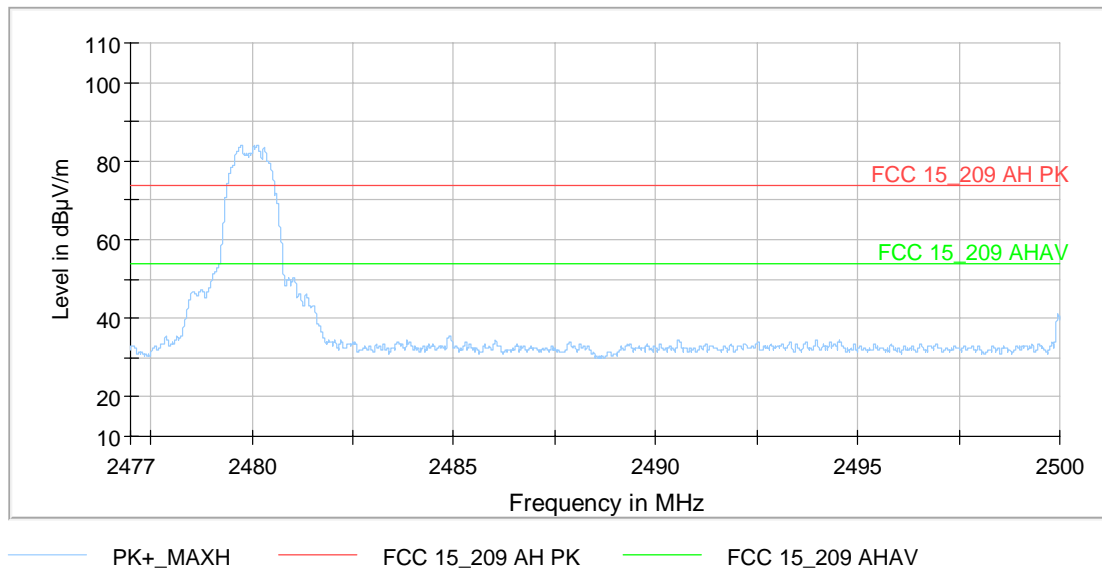

Transmitter operates at the lower end of the assigned frequency band (operation mode 16)

Frequency (MHz)	MaxPeak (dBµV/m)	CAverage (dBµV/m)	Limit (dBµV/m)	Margin (dB)	Pol	Azimuth (deg)	Elevation (deg)	Corr. (dB)	Result
No spurious emissions at the band edges were found during the preliminary measurements									
Measurement uncertainty			+2.2 dB / -3.6 dB						

Transmitter operates at the upper end of the assigned frequency band (operation mode 18)

Frequency (MHz)	MaxPeak (dBµV/m)	CAverage (dBµV/m)	Limit (dBµV/m)	Margin (dB)	Pol	Azimuth (deg)	Elevation (deg)	Corr. (dB)	Result
2484.896000	---	46.52	54.00	7.48	V	273.0	90.0	33.6	Passed
2484.896000	58.50	---	74.00	15.50	V	273.0	90.0	33.6	Passed
2499.957214	---	47.29	54.00	6.71	H	99.0	29.0	33.4	Passed
2499.957214	59.67	---	74.00	14.33	H	99.0	29.0	33.4	Passed
Measurement uncertainty			+2.2 dB / -3.6 dB						

UGXZEX304A (BT only module)

162097 UpperBandEdge GHz ch11.rtf: Spurious emissions from 30 MHz to 1 GHz (operation mode 1):

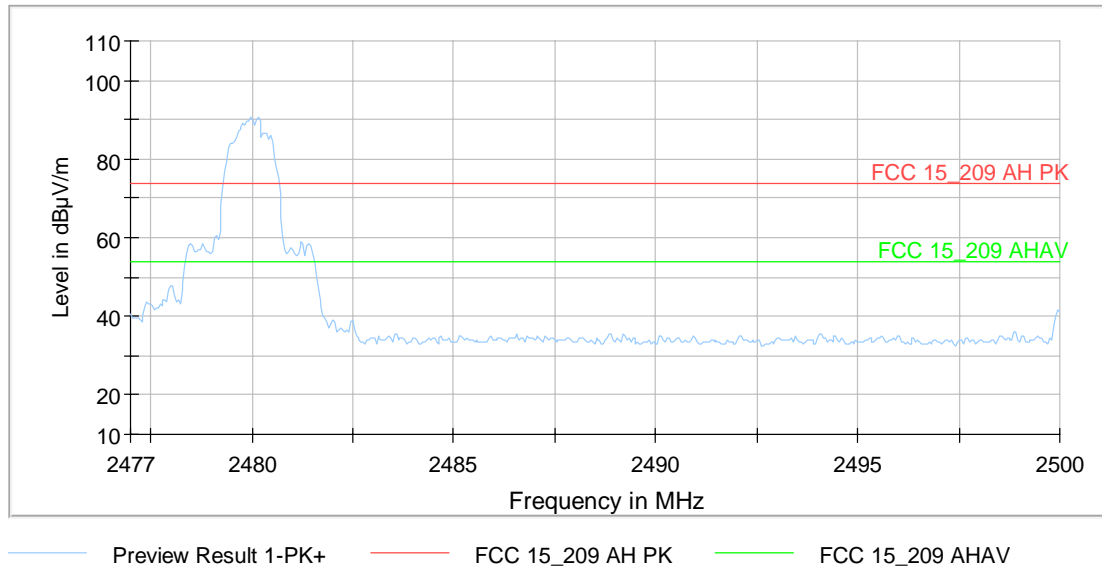

Transmitter operates at the lower end of the assigned frequency band (operation mode 25)

Frequency (MHz)	MaxPeak (dBµV/m)	CAverage (dBµV/m)	Limit (dBµV/m)	Margin (dB)	Pol	Azimuth (deg)	Elevation (deg)	Corr. (dB)	Result
No spurious emissions at the band edges were found during the preliminary measurements									
Measurement uncertainty			+2.2 dB / -3.6 dB						

Transmitter operates at the upper end of the assigned frequency band (operation mode 27)

Frequency (MHz)	MaxPeak (dBµV/m)	CAverage (dBµV/m)	Limit (dBµV/m)	Margin (dB)	Pol	Azimuth (deg)	Elevation (deg)	Corr. (dB)	Result
2498.831500	---	46.44	54.00	7.56	V	201.0	120.0	33.4	Passed
2498.831500	58.14	---	74.00	15.86	V	201.0	120.0	33.4	Passed
2499.956045	---	47.35	54.00	6.65	H	103.0	30.0	33.4	Passed
2499.956045	59.26	---	74.00	14.74	H	103.0	30.0	33.4	Passed
Measurement uncertainty			+2.2 dB / -3.6 dB						

5.6.5.5 Simultaneous Transmission (radiated)

Only the plot of the worst case emission is submitted below

No difference in the emissions below 1 GHz compared to the results documented in 5.6.5.2.

**UGKZ7A1001A (BT/WLAN combi module) transmits in WLAN mode on ch 1 &
UGXZEX304A (BT only module) transmits on channel 78**

162097 1-4 GHz WLAN ch1 BtHelm ch78.Rtf: Spurious emissions from 1 GHz to 4 GHz (operation mode 28):

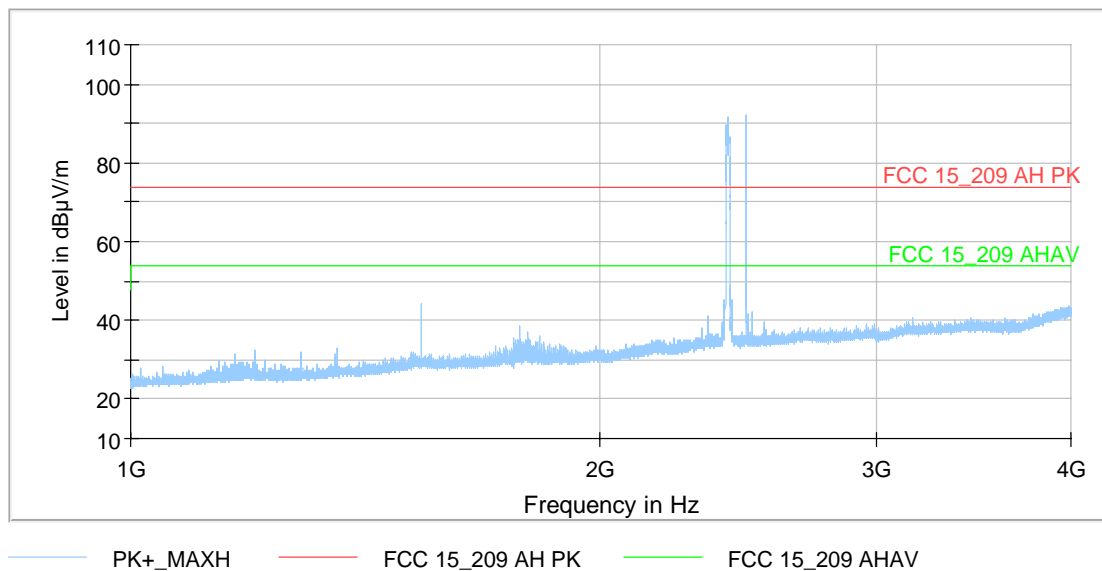

162097 4-12 GHz WLAN ch1 BtHelm ch78.Rtf: Spurious emissions from 4 GHz to 12 GHz (operation mode 28):

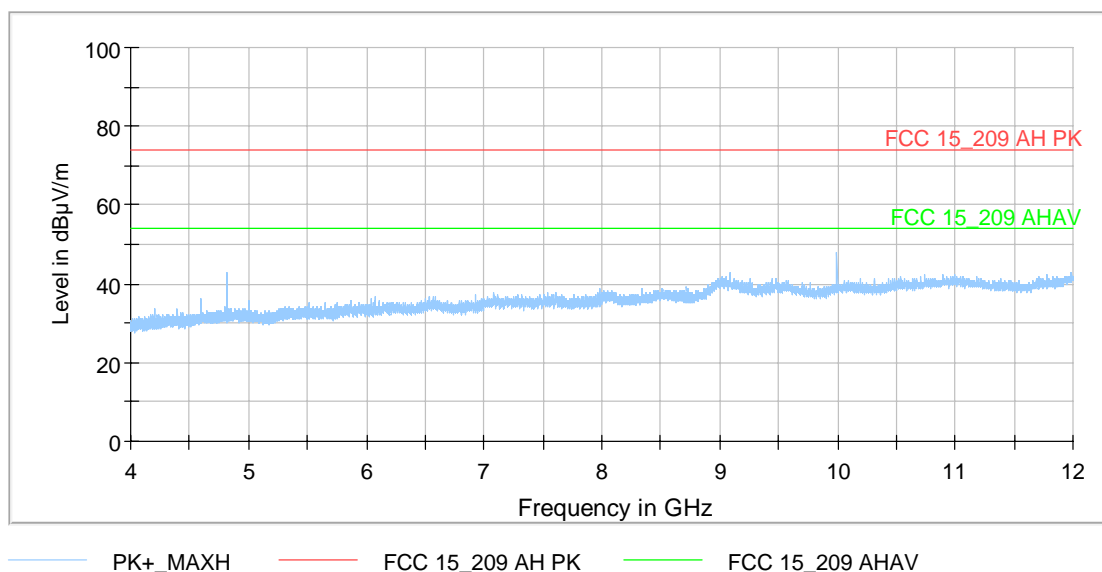

162097 12-18 GHz WLAN ch1 BTHelm ch78.Rtf: Spurious emissions from 12 to 18 GHz (operation mode 28):

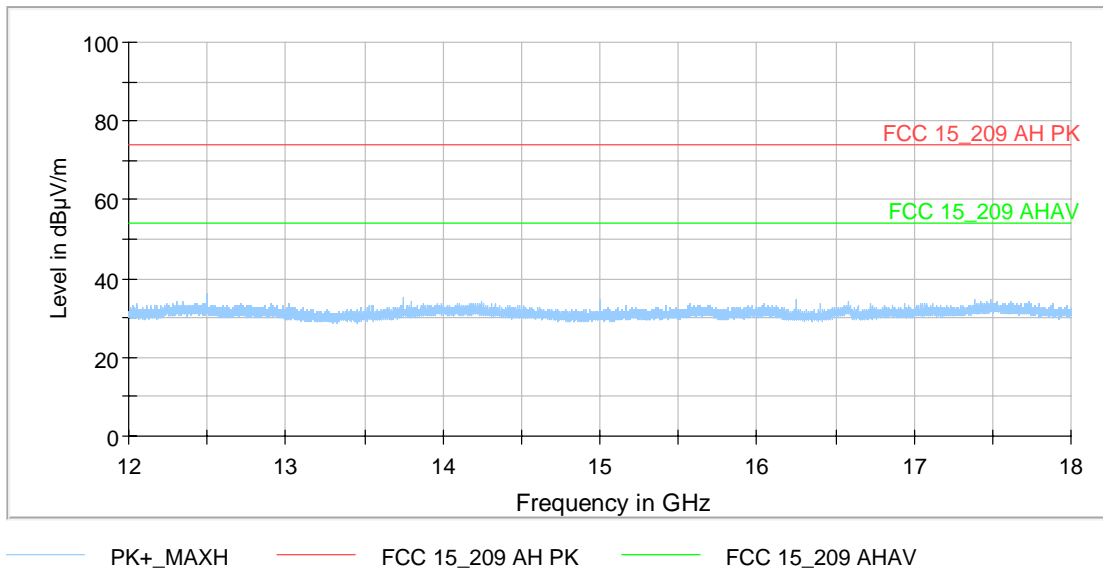

162097 18-26.5 GHz Wifi ch1 BTHelmet ch78.Rtf: Spurious emissions from 18 – 25 GHz (operation mode 28):

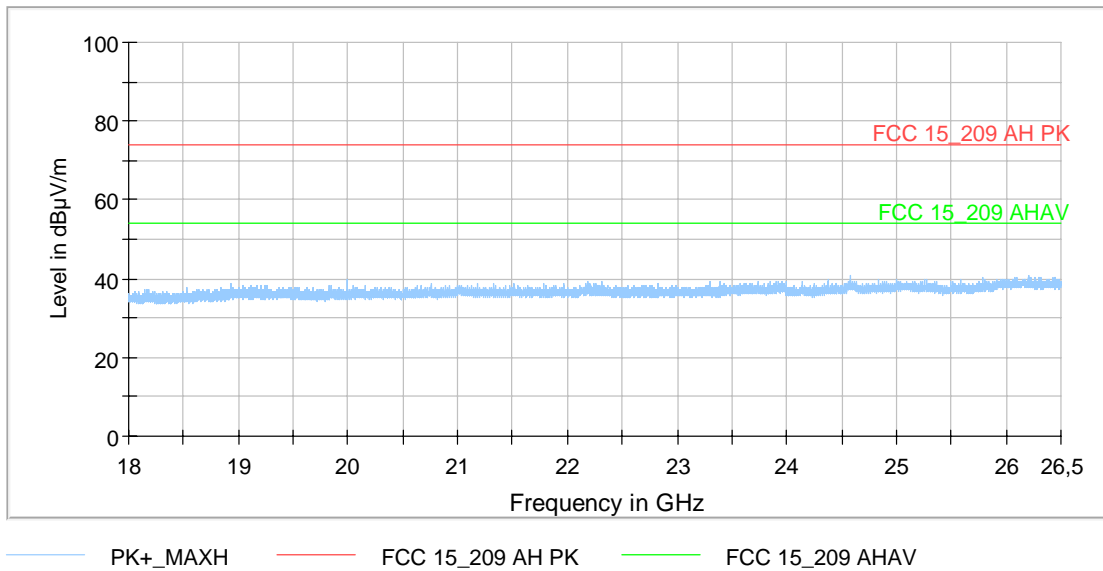

Transmitter operates at the lower end of the assigned frequency band (operation mode 28)

Frequency (MHz)	MaxPeak (dB μ V/m)	CAverage (dB μ V/m)	Limit (dB μ V/m)	Margin (dB)	Pol	Azimuth (deg)	Elevation (deg)	Corr. (dB)	Result
1535.993717	---	43.24	54.00	10.76	V	105.0	59.0	28.7	Passed
1535.993717	55.53	---	74.00	18.47	V	105.0	59.0	28.7	Passed
1773.143000	---	41.13	54.00	12.87	V	240.0	150.0	29.8	Passed
1773.143000	53.70	---	74.00	20.30	V	240.0	150.0	29.8	Passed
1796.550083	---	41.15	54.00	12.85	V	71.0	29.0	29.9	Passed
1796.550083	54.07	---	74.00	19.93	V	71.0	29.0	29.9	Passed
2344.020200	---	46.55	54.00	7.45	V	78.0	29.0	33.3	Passed
2344.020200	58.86	---	74.00	15.14	V	78.0	29.0	33.3	Passed
2410.349683	---	91.65	54.00	-37.65	H	269.0	120.0	33.5	Fund.
2410.349683	94.17	---	74.00	-20.17	H	269.0	120.0	33.5	Fund.
2479.903700	---	91.07	54.00	-37.07	H	83.0	0.0	33.6	Fund.
2479.903700	94.01	---	74.00	-20.01	H	83.0	0.0	33.6	Fund.
2499.955400	---	47.28	54.00	6.72	H	70.0	0.0	33.4	Passed
2499.955400	58.59	---	74.00	15.41	H	70.0	0.0	33.4	Passed
2546.795617	---	46.80	54.00	7.20	V	304.0	150.0	33.7	Passed
2546.795617	59.01	---	74.00	14.99	V	304.0	150.0	33.7	Passed
4823.961500	---	42.84	54.00	11.16	V	237.0	120.0	-1.6	Passed
4823.961500	48.05	---	74.00	25.95	V	237.0	120.0	-1.6	Passed
9999.826995	54.23	---	74.00	19.77	V	52.0	60.0	7.3	Passed
9999.826995	---	47.32	54.00	6.68	V	52.0	60.0	7.3	Passed
19999.540000	---	39.45	54.00	14.55	V	317.0	120.0	6.9	Passed
19999.540000	48.17	---	74.00	25.83	V	317.0	120.0	6.9	Passed
Measurement uncertainty			+2.2 dB / -3.6 dB						

**UGKZ7A1001A (BT/WLAN combi module) transmits in Bluetooth mode on ch 0 &
UGXZEX304A (BT only module) transmits on channel 78**

162097 1-4 GHz BtSmart ch0 BtHelm ch78.Rtf: Spurious emissions from 1 GHz to 4 GHz (operation mode 29):

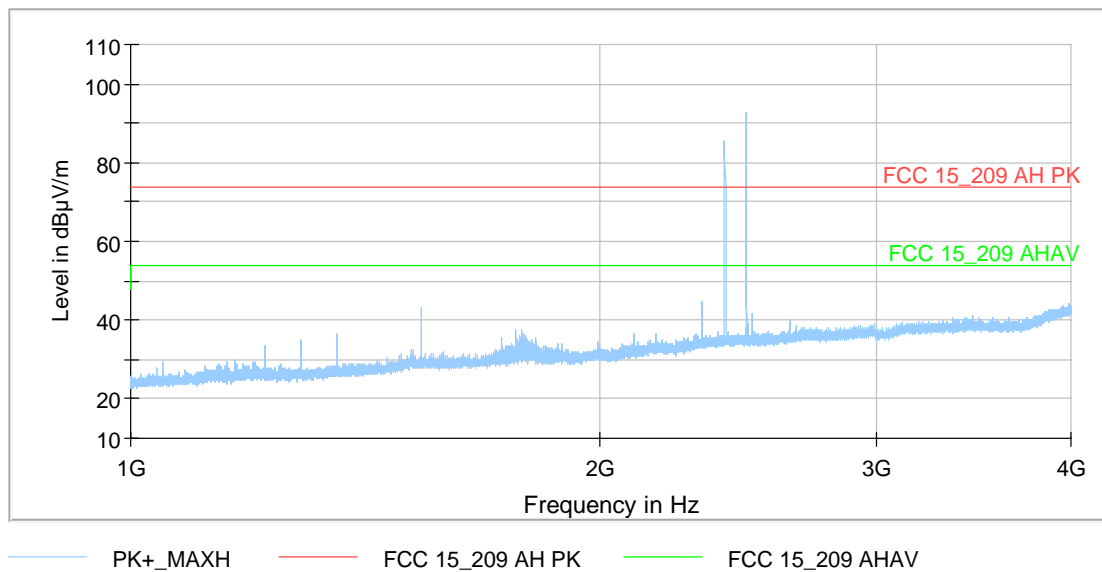

162097 4-12 GHz BtSmart ch0 BtHelm ch78.Rtf: Spurious emissions from 4 GHz to 12 GHz (operation mode 29):

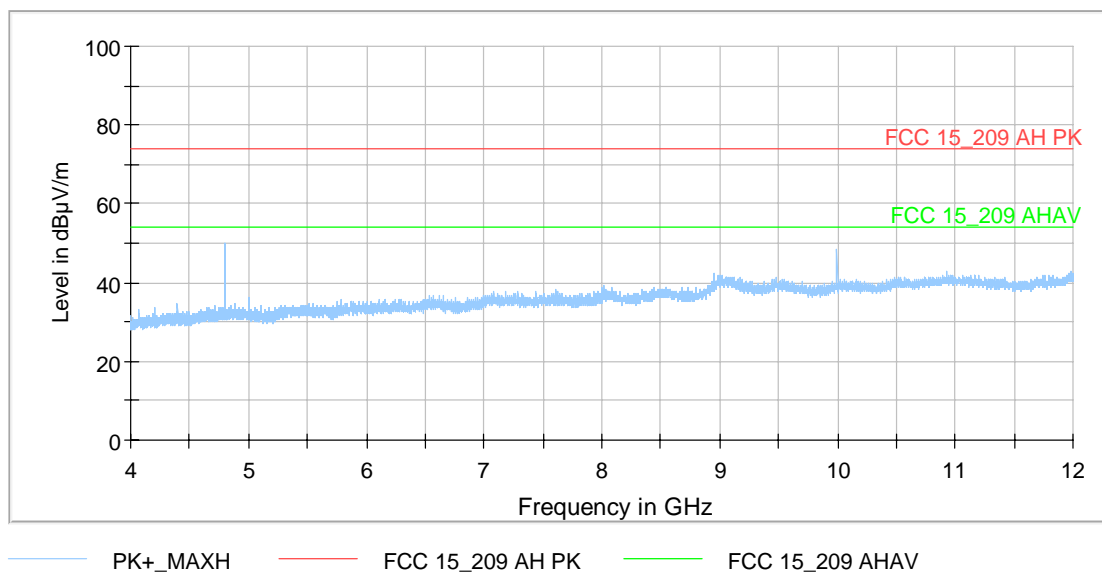

162097 12-18 GHz BTSmart ch0 BTHelm ch78.Rtf: Spurious emissions from 12 to 18 GHz (operation mode 29):

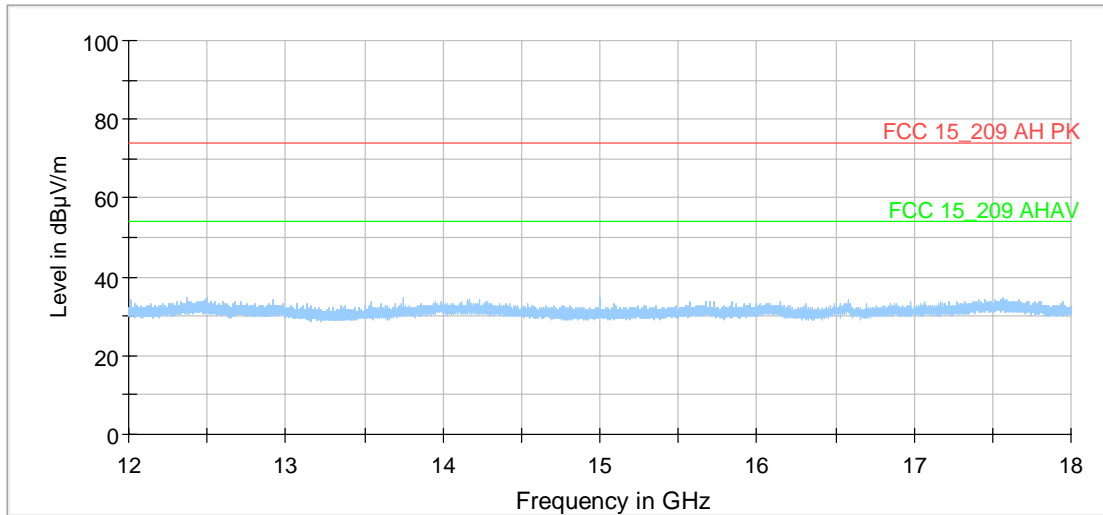

— PK+_MAXH — FCC 15_209 AH PK — FCC 15_209 AHAV

162097 18-26,5 GHz Wifi ch1 BTHelmet ch78.Rtf: Spurious emissions from 18 – 25 GHz (operation mode 29):

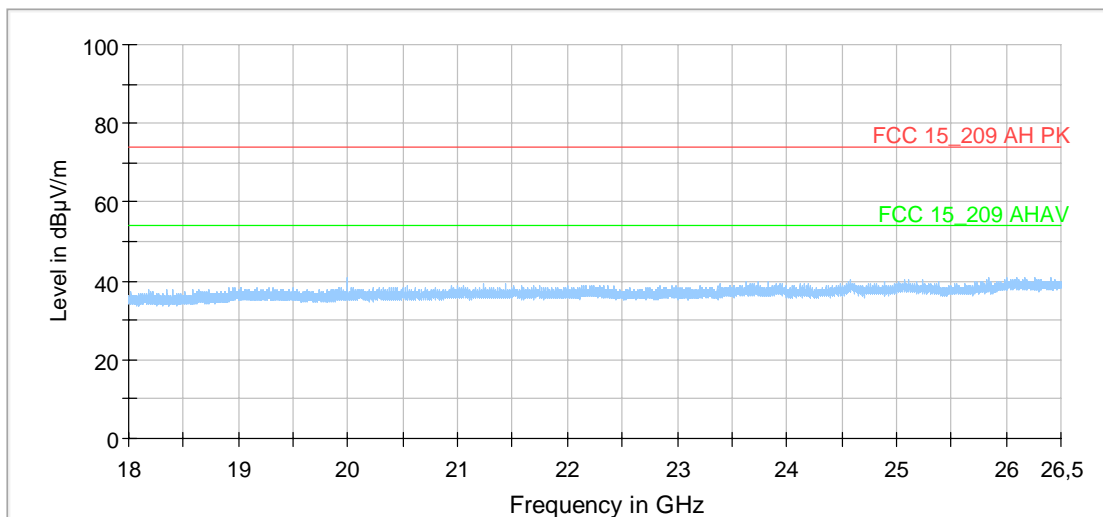

— PK+_MAXH — FCC 15_209 AH PK — FCC 15_209 AHAV

Transmitter operates at the lower end of the assigned frequency band (operation mode 29)

Frequency (MHz)	MaxPeak (dBμV/m)	CAverage (dBμV/m)	Limit (dBμV/m)	Margin (dB)	Pol	Azimuth (deg)	Elevation (deg)	Corr. (dB)	Result
1535.989717	---	42.02	54.00	11.98	H	119.0	30.0	28.7	Passed
1535.989717	54.22	---	74.00	19.78	H	119.0	30.0	28.7	Passed
1764.740200	---	41.00	54.00	13.00	V	241.0	150.0	29.7	Passed
1764.740200	53.13	---	74.00	20.87	V	241.0	150.0	29.7	Passed
1778.315217	---	41.11	54.00	12.89	V	99.0	90.0	29.8	Passed
1778.315217	53.53	---	74.00	20.47	V	99.0	90.0	29.8	Passed
2324.249900	---	45.67	54.00	8.33	H	104.0	30.0	33.1	Passed
2324.249900	58.75	---	74.00	15.25	H	104.0	30.0	33.1	Passed
2402.185500	---	82.13	54.00	-28.13	V	83.0	30.0	33.5	Fund.
2402.185500	85.87	---	74.00	-11.87	V	83.0	30.0	33.5	Fund.
2479.825300	---	90.78	54.00	-36.78	V	291.0	150.0	33.6	Fund.
2479.825300	94.26	---	74.00	-20.26	V	291.0	150.0	33.6	Fund.
2499.964500	---	47.37	54.00	6.63	H	107.0	29.0	33.4	Passed
2499.964500	60.14	---	74.00	13.86	H	107.0	29.0	33.4	Passed
2640.828900	---	47.17	54.00	6.83	V	68.0	90.0	34.5	Passed
2640.828900	58.93	---	74.00	15.07	V	68.0	90.0	34.5	Passed
4804.213805	53.92	---	74.00	20.08	V	237.0	120.0	-1.7	Passed
4804.213805	---	49.64	54.00	4.36	V	237.0	120.0	-1.7	Passed
4999.902900	44.29	---	74.00	29.71	V	246.0	150.0	-1.6	Passed
4999.902900	---	34.46	54.00	19.54	V	246.0	150.0	-1.6	Passed
9999.835595	---	47.70	54.00	6.30	V	44.0	90.0	7.3	Passed
9999.835595	53.36	---	74.00	20.64	V	44.0	90.0	7.3	Passed
12499.790000	---	35.63	54.00	18.37	V	271.0	150.0	12.1	Passed
12499.790000	44.44	---	74.00	29.56	V	271.0	150.0	12.1	Passed
19999.625000	---	38.59	54.00	15.41	V	255.0	150.0	6.9	Passed
19999.625000	48.23	---	74.00	25.77	V	255.0	150.0	6.9	Passed
Measurement uncertainty			+2.2 dB / -3.6 dB						

TEST EQUIPMENT USED FOR THE TEST:

5 - 29, 31 – 39, 41 – 51, 72

6 Test Equipment

No.	Test equipment	Type	Manufacturer	Serial No.	PM. No.	Cal. Date	Cal. Due
5	EMI Software	EMC32	Rohde & Schwarz	100061	481022	-	-
8	HF-Cable	Sucoflex 104	Huber+Suhner	517406	482391	Annual verification (system cal.)	
29	Fully anechoic chamber M20	-	Albatross Projects	B83107-E2439-T232	480303	Weekly verification (system cal.)	
30	Spectrum Analyser	FSU46	Rohde & Schwarz	200125	480956	07.03.2017	01.03.2018
31	Signal & Spectrum Analyzer	FSW43	Rohde & Schwarz	100586	481720	24.02.2016	01.02.2018
32	Controller	MCU	Maturo	MCU/043/971107	480832	-	-
33	Turntable	DS420HE	Deisel	420/620/80	480315	-	-
34	Antenna support	AS615P	Deisel	615/310	480187	-	-
36	Antenna (Log.Per.)	HL050	Rohde & Schwarz	100438	481170	27.08.2014	01.08.2017
37	Standard Gain Horn 11.9 GHz – 18 GHz	18240-20	Flann Microwave	483	480294	Six month verification (system cal.)	
39	Standard Gain Horn 17.9 GHz – 26.7 GHz	20240-20	Flann Microwave	411	480297	Six month verification (system cal.)	
41	RF-cable No. 3	Sucoflex 106B	Huber&Suhner	0563/6B / Kabel 3	480670	Weekly verification (system cal.)	
42	RF-cable No. 40	Sucoflex 106B	Huber&Suhner	0708/6B / Kabel 40	481330	Weekly verification (system cal.)	
43	Loop antenna	HFH2-Z2	Rohde & Schwarz	832609/014	480059	29.02.2016	29.02.2018
44	Antenna (Bilog)	CBL6112B	Schaffner EMV GmbH (-Chase)	2688	480328	19.06.2017	01.06.2020
46	RF-cable 2 m	KPS-1533-800-KPS	Insulated Wire	-	480302	Six month verification (system cal.)	
47	Kabel 36	Sucoflex 106B	Suhner	500003/6B / Kabel 36	481680	Weekly verification (system cal.)	
49	Preamplifier	JS3-00101200-23-5A	Miteq	681851	480337	18.02.2016	18.02.2018
50	Preamplifier	JS3-12001800-16-5A	Miteq	571667	480343	18.02.2016	18.02.2018
51	Preamplifier	JS3-18002600-20-5A	Miteq	658697	480342	17.02.2016	17.02.2018
52	4 GHz High Pass Filter	WHKX4.0/18 G-8SS	Wainwright Instruments	1	480587	Weekly verification (system cal.)	
60	Power Meter	NRVD	Rohde & Schwarz	833697/030	480589	18.02.2016	18.02.2018
61	Peak Power Sensor	NRV-Z32	Rohde & Schwarz	849745/016	480551	18.02.2016	18.02.2018

