

TEST REPORT
No.: 17-1-0065901T60a

According to:

FCC Regulations

Part 15.205
Part 15.209
Part 15.407

ISED-Regulations

RSS-Gen, Issue 4
RSS-247, Issue 2

for

Robert Bosch Car Multimedia GmbH

AIVIP32R0

FCC-ID: YBN-AIVIP32R0
IC: 9595A-AIVIP32R0
PMN: AIVIP32R0
HVIN: AIVIP32R0
FVIN: X128







| Laboratory Accreditation and Listings | | | |
|--|---|---|--|
|  DAkks Deutsche Akkreditierungsstelle D-PL-12047-01-01 |  FEDERAL COMMUNICATIONS COMMISSION FCC USA MRA US-EU 0003 |  Industry Canada Reg. No.: 3462D-2 Reg. No.: 3462D-3 |  Voluntary Controls for Electromagnetic Emissions Reg. No.: R-2666 C-2914, T-1967, G-301 |
|  WiFi ALLIANCE AUTHORIZED RF LABORATORY |  ctia Authorized Test Lab Lab Code: 20011130-00 | | |
| accredited according to DIN EN ISO/IEC 17025 | | | |
| CETECOM GmbH Laboratory Radio Communications & Electromagnetic Compatibility Im Teelbruch 116 • 45219 Essen • Germany Registered in Essen, Germany, Reg. No.: HRB Essen 8984 Tel.: + 49 (0) 20 54 / 95 19-954 • Fax: + 49 (0) 20 54 / 95 19-964 E-mail: info@cetecom.com • Internet: www.cetecom.com | | | |

Table of Contents

| | |
|---|-----------|
| 1. SUMMARY OF TEST RESULTS..... | 3 |
| 1.1. Tests measurement overview according to US CFR Title 47, Subpart 15C..... | 3 |
| 1.2. Attestation:..... | 6 |
| 2. ADMINISTRATIVE DATA | 7 |
| 2.1. Identification of the testing laboratory..... | 7 |
| 2.2. Test location | 7 |
| 2.3. Organizational items | 7 |
| 2.4. Applicant’s details | 7 |
| 2.5. Manufacturer’s details | 7 |
| 3. EQUIPMENT UNDER TEST (EUT)..... | 8 |
| 3.1. Certification Data of Main EUT declared by Applicant | 8 |
| 3.2. WLAN 5 GHz 802.11a/n Technical Data Of Main EUT as Declared by Applicant | 9 |
| 3.3. EUT: Type, S/N etc. and short descriptions used in this test report | 10 |
| 3.4. Auxiliary Equipment (AE): Type, S/N etc. and short descriptions..... | 10 |
| 3.5. EUT set-ups | 10 |
| 3.6. EUT operating modes | 11 |
| 4. DESCRIPTION OF TEST SYSTEM SET-UP’S | 12 |
| 4.1. Test system set-up for conducted measurements on antenna port | 12 |
| 4.2. Test system set-up for radiated magnetic field measurements below 30 MHz..... | 14 |
| 4.3. Test system set-up for radiated electric field measurement 30 MHz to 1 GHz | 15 |
| 4.4. Test system set-up for radiated electric field measurement above 1 GHz | 16 |
| 5. MEASUREMENTS | 17 |
| 5.1. Duty-Cycle..... | 17 |
| 5.2. RF-Parameter - Transmitter Peak output power (conducted and radiated)..... | 19 |
| 5.3. RF Parameter - 26 dB and 99% occupied Bandwidth..... | 26 |
| 5.4. RF Parameter – Peak Power Spectral Density (PPSD)..... | 28 |
| 5.5. General Limit - Radiated field strength emissions below 30 MHz..... | 32 |
| 5.6. General Limit - Radiated field strength emissions, 30 MHz - 1 GHz..... | 35 |
| 5.7. General Limit - Radiated emissions, above 1 GHz..... | 38 |
| 5.8. RF-Parameter - Radiated Band-Edge compliance measurements..... | 45 |
| 5.9. Measurement uncertainties | 52 |
| 6. ABBREVIATIONS USED IN THIS REPORT | 53 |
| 7. ACCREDITATION DETAILS OF CETECOM’S LABORATORIES AND TEST SITES | 53 |
| 8. INSTRUMENTS AND ANCILLARY..... | 54 |
| TC” | 54 |
| 9. VERSIONS OF TEST REPORTS (CHANGE HISTORY) | 57 |

| Table of Annex | | | |
|---|-----------------------------|--|--------------------|
| Annex No. | Contents | Reference Description | Total Pages |
| Annex 1 | Test results | CETECOM-TR17-1-0065901T60a-A1 | 408 |
| Annex 2 | External photographs of EUT | CETECOM- TR17-1-0065901T58a | 9 |
| Annex 3 | Internal photographs of EUT | AIVI_Scope2_Internal_Pictures | 8 |
| Annex 4 | Test set-up photographs | CETECOM- TR17-1-0065901T58a -A4 | 9 |
| The listed attachments are an integral part of this report. | | | |

1. Summary of test results

The test results apply exclusively to the test samples as presented in this Report. The CETECOM GmbH does not assume responsibility for any conclusions and generalizations taken in conjunction with other specimens or samples of the type of the item presented to tests.

The test results apply exclusively to the test samples as presented in this report. The CETECOM GmbH does not assume responsibility for any conclusions and generalizations taken in conjunction with other specimens or samples of the type of the item presented to tests. Also we refer on special conditions which the applicant should fulfill according §2.927 to §2.948, special focus regarding modification of the equipment and availability of sample equipment for market surveillance tests.

The presented Equipment Under Test(in this report, hereinafter referred as EUT) : integrates total 1 module & supports following technologies :

EUT supported Technologies which are not tested within this test report

| EUT supported Technology | Test Report Reference |
|--|----------------------------|
| Bluetooth FHSS (BR-EDR) Modes: 2402 – 2480 MHz | CETECOM_TR17-1-0065901T58a |
| WLAN 802.11b/g/n(HT20) Modes: 2412 – 2462 MHz | CETECOM_TR17-1-0065901T59a |

EUT supported Technologies which are tested within this test report

- **WLAN 802.11a/n(HT20)/n(HT40)/ac(HT20)/ac(HT40)/ac(HT80)Modes: 5150–5850 MHz**

Following test cases have been performed to show compliance with valid Part 15.205/15.209/15.407 of the FCC CFR Title 47 Rules, Edition 4th November 2016.

1.1. Tests measurement overview according to US CFR Title 47, Subpart 15C

| Test cases | Port | References and Limits | | | EUT set-up | EUT op. mode | Result |
|------------------------|------------------------------|------------------------------|------------------------------|----------------------------------|------------|--------------|-----------|
| | | FCC Standard | RSS Standard | Test limit | | | |
| TX-Mode | | | | | | | |
| 99% occupied bandwidth | Antenna terminal (conducted) | 2.1049(h) | RSS-Gen, Issue 4 Chapter 6.6 | 99% Power bandwidth | 2 | 1 | Pass |
| 26 dB bandwidth | Antenna terminal (conducted) | §15.303 + §15.407(a) (2) (5) | RSS-Gen, Issue 4 Chapter 6.6 | 26 dB spectral density bandwidth | 2 | 1 | Pass |
| Duty-Cycle | Antenna terminal (conducted) | KDB789033 + ANSI C63.10:2013 | KDB789033 + ANSI C63.10:2013 | No Limit Criteria | 2 | 1 | Performed |

| | | | | | | | |
|-----------------------------|---|--|---|--|----|----|---|
| Maximum output power | Antenna terminal (conducted) | §15.407(a) | RSS-247, Issue 2 Chapter | Power Limits (if Antenna Gain < 6 dBi) | 2 | 1 | Pass |
| | | (1)(iv) 5.15-5.25 GHz Client devices | 6.2.1.1 | 250 mW | | | |
| | | (2) 5.25-5.35 GHz & 5.47-5.725 GHz | 6.2.2.1 | lesser of 250mW or 11dBm+10logB | | | |
| | | (3) 5.725-5.85 GHz | 6.2.3.1 6.2.4.1 | 1 W | | | |
| Peak Power Spectral density | Antenna terminal (conducted) | §15.407(a) | RSS-247, Issue 2 Chapter | Power Spectral Density Limits (if Antenna Gain < 6 dBi) | 2 | 1 | Pass |
| | | (1)(iv) 5.15-5.25 GHz Client devices | 6.2.1.1 | 11dBm/MHz | | | |
| | | (2) 5.25-5.35 GHz & 5.47-5.725 GHz | 6.2.2.1 | 11dBm/MHz | | | |
| | | (3) 5.725-5.85 GHz | 6.2.3.1 6.2.4.1 | 30dBm/500kHz | | | |
| Maximum e.i.r.p. power | Antenna terminal (conducted) + Antenna Gain | §15.407(a) | RSS-247, Issue 2 Chapter | e.i.r.p. Limits (if Antenna Gain < 6 dBi) | 2 | 1 | Pass + Applicants declaration: Antenna Gain |
| | | (1)(iv) 5.15-5.25 GHz Client devices | 6.2.1.1 | 250 mW + 6 dBi | | | |
| | | (2) 5.25-5.35 GHz & 5.47-5.725 GHz | 6.2.2.1 | lesser of 250mW or 11dBm+10logB + 6 dBi | | | |
| | | (3) 5.725-5.85 GHz | 6.2.3.1 6.2.4.1 | 1 W + 6 dBi | | | |
| Antenna gain information | Antenna terminal (conducted) | §15.407(a) (1)(2)(3) | RSS-247, Issue 2 chapter 6.2.1.1 6.2.2.1 6.2.3.1 6.2.4.1 | < 6dBi or if Antenna directional Gain > 6dBi reduction of Max. power & power spectral density by the amount in dB that the directional gain of the antenna exceeds 6 dBi | -- | -- | Applicants declaration: Antenna Gain |

| | | | | | | | |
|---|---|---|---|---|-----------|------------|---|
| <p>General field strength emissions within restricted bands + Band-Edge compliance radiated</p> | <p>Enclosure + Inter-connecting cables (radiated)</p> | <p>§15.407(b) (1)(2)(3)(4)(5)(6)(7)(8) §15.205 + §15.209</p> | <p>RSS-Gen., Issue 4 + RSS-247, Issue 2 Chapter 6.2.1.2, 6.2.2.2 6.2.3.2, + 6.2.4.2 RSS-Gen., Issue 4 + RSS-247, Issue 2 Chapter 6.2.1.2, 6.2.2.2 6.2.3.2, + 6.2.4.2</p> | <p>5150-5250 MHz 5250-5350 MHz 5470-5725 MHz all emissions outside operating band shall not exceed -27 dBm/MHz e.i.r.p. 5725-5850 MHz Spectrum Mask acc. to (4)(i) Restricted band limits + General field strength limits</p> | <p>1</p> | <p>1,2</p> | <p>Pass</p> |
| <p>Transmit power control + Dynamic frequency selection (DFS)</p> | <p>Antenna terminal (conducted)</p> | <p>§15.407 (h1)(h2)</p> | <p>RSS-Gen., Issue 4 + RSS-247, Issue 2 Chapter 6.3</p> | <p>Requirements: Masters Active clients Passive clients</p> | <p>--</p> | <p>--</p> | <p>Remark 1)</p> |
| <p>Discontinuous transmissions + Device security</p> | <p>FIRMWARE</p> | <p>§15.407(c) + §15.407(i)</p> | <p>RSS-247, Issue 2 Chapter 6.4 a + b + c</p> | <p>No transmissions in case of either absence of information to transmit or operational failure + Protection of firmware by unauthorized parties</p> | <p>--</p> | <p>--</p> | <p>Not tested Applicants declaration of implementation</p> |
| <p>AC-Power Lines Conducted Emissions</p> | <p>AC-Power lines or Battery Charger</p> | <p>§15.207(a)</p> | <p>RSS-Gen, Issue 4: Chapter 8.8 Table 3</p> | <p>AC Power line conducted limits</p> | <p>--</p> | <p>--</p> | <p>Not applicable</p> |

Remark 1) Please refer to separate test report 1-4552/17-01

| Specific Absorption Rate (SAR) Measurements (separation distance user to RF-radiating element within 20cm) | | | | | | |
|---|--|--|---|------------|--------------|---|
| Test cases | Port | References & Limits | | EUT set-up | EUT op. mode | Result |
| | | FCC Standard RSS Section | Test Limit | | | |
| Specific Absorption Rate (SAR) requirements | Cabinet + Inter-connecting cables (radiated) | §2.1091 §2.1093 + IEEE 1528-2013 + KDB 865664D01v0r04 | Specific Absorption Rate (SAR) for Devices Used by the General Public (Uncontrolled Environment) : 1.6 W/Kg as averaged over any 1 g tissue | -- | -- | Refer test report Test report no.: CETECOM_TR17-1-0065901T67a |

1.2. Attestation:

I declare that all measurements were performed by me or under my supervision and that all measurements have been performed and are correct to my best knowledge and belief to Innovation , Science and Economic Development (ISED) Canada standards. All requirements as shown in above table are met in accordance with enumerated standards.

.....
Dipl.-Ing. Rachid Acharkaoui
Responsible for test section

.....
Dipl.-Ing N. Perez
Responsible for test report

2. Administrative Data

2.1. Identification of the testing laboratory

| | |
|-------------------------------------|--|
| Company name: | CETECOM GmbH |
| Address: | Im Teelbruch 116 45219 Essen - Kettwig Germany |
| Responsible for testing laboratory: | Dipl.-Ing. Rachid Acharkaoui |
| Deputy: | Dipl.-Ing. Niels Jeß |

2.2. Test location

2.2.1. Test laboratory “CTC”

| | |
|---------------|---|
| Company name: | see chapter 2.1. Identification of the testing laboratory |
|---------------|---|

2.3. Organizational items

| | |
|---|-------------------------|
| Responsible for test report and Project leader: | Dipl.-Ing N. Perez |
| Receipt of EUT: | 2016-12-01 |
| Date(s) of test: | 2017-04-26 - 2017-06-09 |
| Date of report: | 2017-07-01 |
| ----- | |
| Version of template: | 13.02 |

2.4. Applicant’s details

| | |
|-------------------|---|
| Applicant’s name: | Robert Bosch Car Multimedia GmbH |
| Address: | Robert-Bosch-Straße 200 31137 Hildeshim Germany |
| Contact : | Mr. Dirk Zamow |

2.5. Manufacturer’s details

| | |
|----------------------|-------------------|
| Manufacturer’s name: | same as Applicant |
| Address: | same as Applicant |

3. Equipment under test (EUT)

3.1. Certification Data of Main EUT declared by Applicant

| | | | |
|--|--|------------------------|------------------------------|
| EUT Model | AIVIP32R0 | | |
| EUT Type | Car Tuner Navigation System with BT & WLAN | | |
| FCC ID | YBN-AIVIP32R0 | | |
| ISED ID | 9595A-AIVIP32R0 | | |
| Additional Information: Integrated Module | | | |
| Integrated Module | -- | | |
| Module Certification FCC ID | -- | | |
| Number of Integrated Modules | -- | | |
| Additional Information : Supported Technologies | | | |
| Technology | Modes | Frequency Range | Remarks |
| WLAN 5 GHz | WLAN 802.11a/n(HT20)/n(HT40) | 5150 MHz – 5850 MHz | refer chapter 3.2 |
| Bluetooth FHSS | Bluetooth BR-EDR | 2402 MHz – 2480 MHz | not tested under this report |
| WLAN 2.4 GHz | WLAN 802.11b/g/n(HT20) | 2412 MHz – 2462 MHz | not tested under this report |

3.2. WLAN 5 GHz 802.11a/n Technical Data Of Main EUT as Declared by Applicant

| | | | |
|---|--|--|--|
| EUT Model | AIVIP32R0 | | |
| EUT Model Type | Car multimedia system | | |
| EUT Type | Car Tuner Navigation System with BT & WLAN | | |
| EUT Applications | Car Tuner Navigation System with BT & WLAN | | |
| Hardware Version | 001 | | |
| Software Version | SW 344 (X128) | | |
| Firmware Version | -- | | |
| Frequency Channel B.W. (USA bands only)** | U-NII 1: 5150-5250 MHz | <input checked="" type="checkbox"/> Ch 36 40 44 48 | <input checked="" type="checkbox"/> Bandwidth 20 MHz |
| | | <input checked="" type="checkbox"/> Ch. 38 46 | <input checked="" type="checkbox"/> Bandwidth 40 MHz |
| | | <input checked="" type="checkbox"/> Ch. 42 | <input checked="" type="checkbox"/> Bandwidth 80 MHz |
| | U-NII2A: 5250-5350 MHz | <input checked="" type="checkbox"/> Ch 52 56 60 64 | <input checked="" type="checkbox"/> Bandwidth 20 MHz |
| | | <input checked="" type="checkbox"/> Ch. 54 62 | <input checked="" type="checkbox"/> Bandwidth 40 MHz |
| | | <input checked="" type="checkbox"/> Ch. 58 | <input checked="" type="checkbox"/> Bandwidth 80 MHz |
| | U-NII 2C: 5470-5725 MHz | <input checked="" type="checkbox"/> Ch 100 104 108 | <input checked="" type="checkbox"/> Bandwidth 20 MHz |
| | | <input checked="" type="checkbox"/> Ch 112 116 120 | |
| | | <input checked="" type="checkbox"/> Ch 124 128 132 | |
| | | <input checked="" type="checkbox"/> Ch 136 140 | <input checked="" type="checkbox"/> Bandwidth 40 MHz |
| | | <input checked="" type="checkbox"/> Ch. 102 110 118 | |
| | | <input checked="" type="checkbox"/> Ch 126 134 | |
| | U-NII 3: 5725 -5850 MHz | <input checked="" type="checkbox"/> Ch 106 122 | <input checked="" type="checkbox"/> Bandwidth 80 MHz |
| | | <input checked="" type="checkbox"/> Ch 149 153 157 | <input checked="" type="checkbox"/> Bandwidth 20 MHz |
| | | <input checked="" type="checkbox"/> Ch 161 165 | <input checked="" type="checkbox"/> Bandwidth 40 MHz |
| <input checked="" type="checkbox"/> Ch 151 159 | | <input checked="" type="checkbox"/> Bandwidth 40 MHz | |
| <input checked="" type="checkbox"/> Ch 155 | | <input checked="" type="checkbox"/> Bandwidth 80 MHz | |
| Channels Power Settings | +9.5 dBm (According to Applicant's Declaration Max. Rated Power Values) | | |
| 802.11a – Mode OFDM Modulation Data Rates | <input checked="" type="checkbox"/> BPSK 6 Mbps / 9 Mbps <input checked="" type="checkbox"/> QPSK 12 Mbps / 18 Mbps <input checked="" type="checkbox"/> 16-QAM 24 Mbps / 36 Mbps <input checked="" type="checkbox"/> 64-QAM 48 Mbps / 54 Mbps | | |
| 802.11n – Mode OFDM Modulation Data Rates | <input checked="" type="checkbox"/> HT20 (MCS0 – MCS7) 7.2/14.4/21.7/28.9/43.3/57.8/65/72.2 Mbps <input checked="" type="checkbox"/> HT40 (MCS0 – MCS7) 15/30/45/60/90/120/135/150 Mbps | | |
| 802.11ac – Mode OFDM Modulation Data Rates | <input checked="" type="checkbox"/> HT20 (MCS0 – MCS9) 7.2/14.4/21.7/28.9/43.3/57.8/65/72.2 Mbps <input checked="" type="checkbox"/> HT40 (MCS0 – MCS9) 15/30/45/60/90/120/135/150 Mbps <input checked="" type="checkbox"/> HT80 (MCS0 – MCS9) 7.2/14.4/21.7/28.9/43.3/57.8/65/72.2 Mbps | | |
| Antenna Details | <input checked="" type="checkbox"/> External, separate RF-connector | | |
| Installed options (not tested within this test report) | <input checked="" type="checkbox"/> 802.11b/g/n <input checked="" type="checkbox"/> Bluetooth BDR/ EDR <input checked="" type="checkbox"/> GPS | Installed options (not tested within this test report) | |
| Antenna Type | TDK SMD Antenna | | |
| ANT1 Gain (Peak) | 5.3 dBi (2.4GHz BT/ WLAN) | | |
| ANT2 Gain (Peak) | 7.1 dBi (5GHz WLAN) | | |
| Test Mode Settings | Please refer to “Instructions_RadioTypeApproval_9_6_2017” dated 2017-06-09 | | |
| MAX Field Strength (Radiated@3m) | U-NII 1: 5150-5250 MHz | 102.56 dBµV/m (PK) | 98.57 dBµV/m (AV) |
| | U-NII2A: 5250-5350 MHz | 102.26dBµV/m (PK) | 98.28 dBµV/m (AV) |
| | U-NII 2C: 5470-5725 MHz | 103.21 dBµV/m (PK) | 94.96 dBµV/m (AV) |
| | U-NII 3: 5725-5850 MHz | 99.37 dBµV/m (PK) | 95.71 dBµV/m (AV) |
| Power Supply | <input checked="" type="checkbox"/> DC power only: 15 Volt <input checked="" type="checkbox"/> Nominal Test Voltage : 15 Volt | | |
| Special EMI Components | -- | | |
| EUT sample type | <input type="checkbox"/> Production | <input checked="" type="checkbox"/> Pre-Production | <input type="checkbox"/> Engineering |
| FCC label attached | <input type="checkbox"/> yes | <input checked="" type="checkbox"/> no | |

3.3. EUT: Type, S/N etc. and short descriptions used in this test report

| Short description*) | EUT | Type | S/N serial number | HW hardware status | SW software status |
|---------------------|-----------|--|-------------------|--------------------|--------------------|
| EUT A | AIVIP32R0 | Car Tuner Navigation System with BT & WLAN | 0003629 | 001 | SW 344 (X128) |
| EUT B | AIVIP32R0 | Car Tuner Navigation System with BT & WLAN | 0003607 | 001 | SW 344 (X128) |

*) EUT short description is used to simplify the identification of the EUT in this test report.

3.4. Auxiliary Equipment (AE): Type, S/N etc. and short descriptions

| AE short description *) | Auxiliary Equipment | Type | S/N serial number | HW hardware status | SW software status |
|-------------------------|---|------|-------------------|--------------------|--------------------|
| AE 1 | Cable harness reduced for power supply only | -- | -- | -- | -- |
| AE 2 | Cable harness with loadboxes | -- | -- | -- | -- |
| AE 3 | Test Laptop | -- | -- | -- | -- |

*) AE short description is used to simplify the identification of the auxiliary equipment in this test report.

3.5. EUT set-ups

| EUT set-up no. *) | Combination of EUT and AE | Description |
|-------------------|---------------------------|--------------------------|
| set. 1 | EUT B + AE 2 (+ AE3) | Used for radiated tests |
| set. 2 | EUT A + AE 1 + AE3 | Used for conducted tests |

*) EUT set-up no. is used to simplify the identification of the EUT set-up in this test report.

3.6. EUT operating modes

| EUT operating mode no.*1) | Description of operating modes | Additional information |
|---------------------------|--------------------------------|--|
| op. 1 | TX-Mode DC | With help of special test firmware a continuous traffic mode in duty cycle mode was set-up *2) |
| op. 2 | TX-Mode Burst | With help of special test firmware a continuous traffic mode in burst mode was set-up *2) |
| op. 3 | RX-Mode | With help of special test firmware RX-mode was set-up. *2) |

*1) EUT operating mode no. is used to simplify the test report.

*2) Please refer to document "Instructions_RadioTypeApproval_9_6_2017" dated 2017-06-09 for additional information regarding operating mode setup and output power levels.

For 802.11b the Power level is always **14** and the modulation group is **0**

For 802.11g the Power level is always **11** and the modulation group is **1**

For 802.11n (2,4GHz) the Power level is always **11** and the modulation group is **1**

For 802.11n (5GHz) the Power level is always **10** and the modulation group is **1**

For 802.11a the Power level is always **10** and the modulation group is **1**

For 802.11ac the Power level is always **6** and the modulation group is **1**

4. Description of test system set-up's

4.1. Test system set-up for conducted measurements on antenna port

Conducted Set-up W1

Conducted RF-Setup 1 (W1 Set-up)

General description:

The EUT's RF-signal is coupled out by a suitable antenna coupling connector (1). The signal is first attenuated (2) then connected to the power meter (3) for conducted power measurements. The specific attenuation loss is determined prior to the measurement within a set-up attenuation measurement. These are then taken into account by correcting the measurement readings.

Schematic:

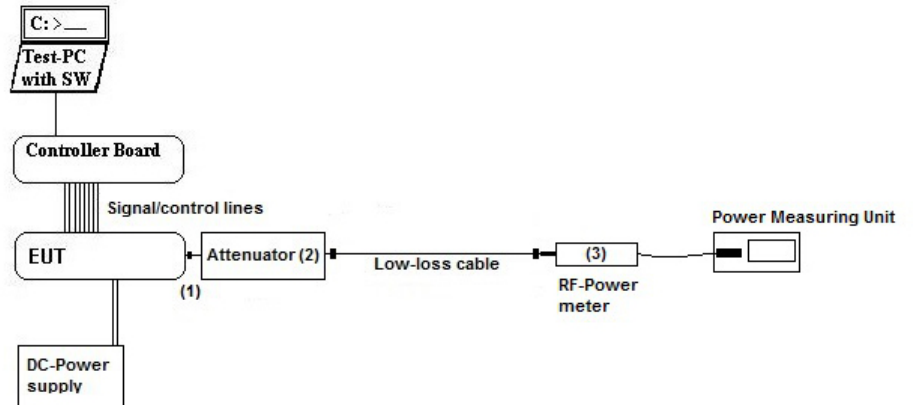

Testing method:

ANSI C63.10:2013,
KDB 789033 D02 General UNII Test Procedures New Rules v01r04

Used Equipment

| Passive Elements | Test Equipment | Remark: |
|--|---|---|
| <input checked="" type="checkbox"/> 20 dB Attenuator | <input checked="" type="checkbox"/> Power Meter | See List of equipment under each test case and chapter 6 for calibration info |
| <input checked="" type="checkbox"/> Low loss RF-cables | <input checked="" type="checkbox"/> DC-Power Supply | |
| <input checked="" type="checkbox"/> | <input checked="" type="checkbox"/> Spectrum-Analyser | |

Measurement uncertainty

See chapter 5.7

Conducted Set-up W2

Conducted RF-Setup 2 (W2 Set-up)

General description: The EUT's RF-signal is coupled out by a suitable antenna coupling connector (1). The signal is first attenuated (2) then connected to spectrum-analyzer (4) for RF-conducted measurements. The specific attenuation loss is determined prior to the measurement within a set-up attenuation measurement. These are then taken into account by correcting the measurement readings of the spectrum-analyzer.

Schematic:

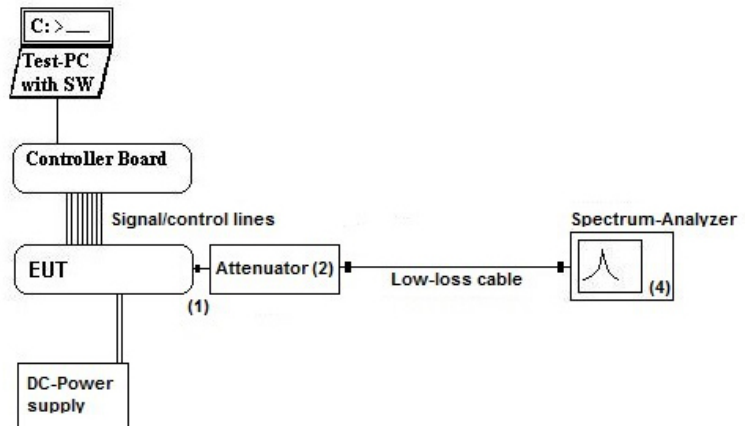

Testing method: ANSI C63.10:2013,
KDB 789033 D02 General UNII Test Procedures New Rules v01r04

| Used Equipment | Passive Elements | Test Equipment | Remark: |
|----------------|--|---|---|
| | <input checked="" type="checkbox"/> 20 dB Attenuator | <input checked="" type="checkbox"/> Power Meter | See List of equipment under each test case and chapter 6 for calibration info |
| | <input checked="" type="checkbox"/> Low loss RF-cables | <input checked="" type="checkbox"/> DC-Power Supply | |
| | | <input checked="" type="checkbox"/> Spectrum-Analyser | |

Measurement uncertainty See chapter 5.7

4.2. Test system set-up for radiated magnetic field measurements below 30 MHz

Specification: ANSI C63.4-2014 §5.3, §8.2.1, §8.3.1.1+§8.3.2.1 , ANSI C63.10-2013 chapter 6.4 (§6.4.4.2)

General Description: Evaluating the radiated field emissions are done first by an exploratory emission measurement and a final measurement for most critical frequencies determined.

The loop antenna was placed at 1 m height above ground plane and 3 m measurement distance from set-up for investigations. Because of reduced measurement distance, correction data were applied, as stated in chapter “General Limit - Radiated field strength emissions below 30 MHz“. The tests are performed in the semi anechoic room recognized by the regulatory commission.

Schematic:

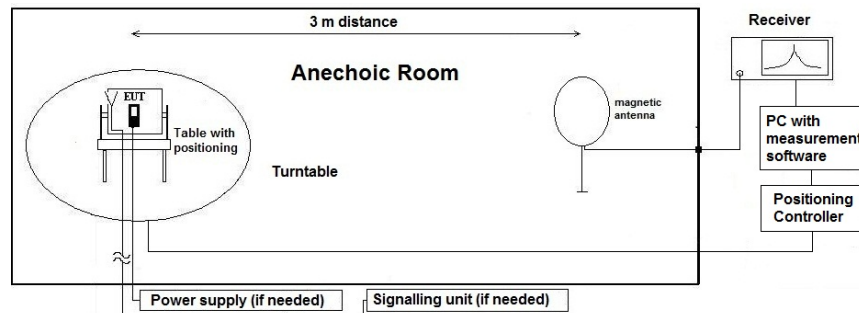

Testing method:

Exploratory, preliminary measurement

The EUT and its associated accessories are placed on a non-conductive position manipulator (tipping device) of 0.8 m height which is placed on the turntable. By rotating the turntable (step 90°, range 0° to 360°) and the EUT itself either on 3-orthogonal axis (portable equipment) or 2-orthogonal axis (defined operational position of EUT), the emission spectrum was recorded. The loop antenna was moved at least to 2-perpendicular axes (antenna vector in direction of EUT and parallel to EUT) in order to maximize the emissions. The results are documented in a diagram. Critical frequencies (low margin to limit) are saved within a data reduction table for further investigations. If various operating modes are supported, further investigations are made to find the worst-case. Also the interconnection cables and equipment position were varied in order to maximize the emissions.

Final measurement on critical frequencies

Based on the exploratory measurements, the most critical frequencies are re-measured by maintaining the EUT’s worst-case operation mode, cable position, etc.

First a frequency zoom around the critical frequency is done to locate the frequency more precisely. After this step, for all identified critical frequencies, the maximum peak was determined.

Following parameters were varied: the turntable angle continuously in the range 0 to 360 degree, the EUT itself either over 3-orthogonal axis (not defined usage position) or 2-orthogonal axis (defined usage position).

On the determined worst-case position, a final measurement with necessary bandwidth and detector according standard has been carried out.

Formula:

$$E_C = E_R + AF + C_L + D_F - G_A$$

$$M = L_T - E_C$$

AF = Antenna factor

C_L = Cable loss

D_F = Distance correction factor

E_C = Electrical field – corrected value

E_R = Receiver reading

G_A = Gain of pre-amplifier (if used)

L_T = Limit

M = Margin

All units are dB-units, positive margin means value is below limit.

Distance correction:

Reference for applied correction (extrapolating) factors due to reduced measurement distance:

ANSI C63.10:2013, §6.4.4.2 - Equations (2) + (3) + (4)

4.3. Test system set-up for radiated electric field measurement 30 MHz to 1 GHz

Specification: ANSI C63.4-2014 chapter 8.2.3, ANSI C63.10-2013 chapter 6.5

General Description: Evaluating the field emissions have to be done first by an exploratory emissions measurement and a final measurement for most critical frequencies. The tests are performed in a NSA-compliant semi anechoic room (SAR) recognized by the regulatory commissions.

Schematic:

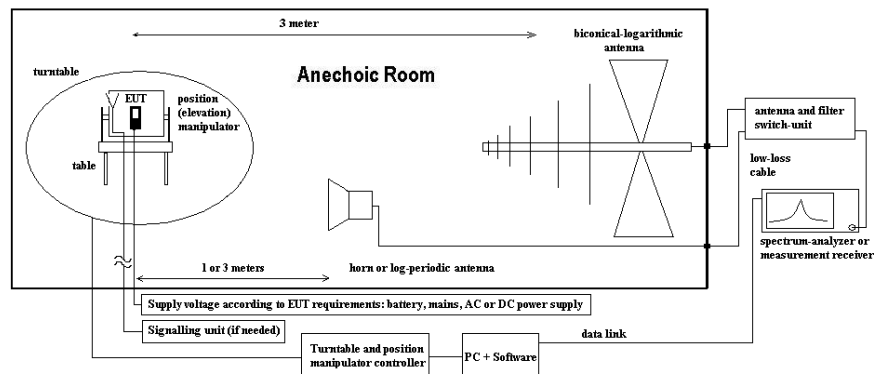

Testing method:

Exploratory, preliminary measurements

The EUT and its associated accessories are placed on a non-conductive position manipulator (tipping device) of 0.8 m height which is placed on the turntable. By rotating the turntable (range 0° to 360°, step 90°) and the EUT itself either on 3-orthogonal axis (portable equipment) or 2-orthogonal axis (defined operational position of EUT) the emission spectrum and its characteristics was recorded with an EMI-receiver, broadband antenna and software.

Measurement antenna: horizontal and vertical, heights: 1,0 m and 1,82 m as worst-case determined by an exploratory emission measurements. The results are documented in a diagram. Critical frequencies (low margin to limit) are saved within a table for further investigations. If various operating modes are supported, further investigations are made to find the worst-case of them. Also the interconnection cables and equipment position were varied in order to maximize the emissions.

Final measurement on critical frequencies

Based on the exploratory measurements, the most critical frequencies are re-measured by maintaining the EUT's worst-case operation mode, cable position, etc. either on 10m OATS or 3m semi-anechoic room.

First a frequency zoom around the critical frequency is done to locate the frequency more precisely. After this step, for all identified critical frequencies, the maximum peak was determined.

Following parameters were varied: the turntable angle continuously in the range 0 to 360 degree, the EUT itself either over 3-orthogonal axis (not defined usage position) or 2-orthogonal axis (defined usage position). The measurement antenna height between 1 m and 4 m.

On the determined worst-case position, a final measurement with necessary bandwidth and detector according standard has been carried out.

Formula:

$$E_C = E_R + AF + C_L + D_F - G_A \quad (1)$$

$$M = L_T - E_C \quad (2)$$

- AF = Antenna factor
- C_L = Cable loss
- D_F = Distance correction factor (if used)
- E_C = Electrical field – corrected value
- E_R = Receiver reading
- G_A = Gain of pre-amplifier (if used)
- L_T = Limit
- M = Margin

All units are dB-units, positive margin means value is below limit.

4.4. Test system set-up for radiated electric field measurement above 1 GHz

Specification: ANSI C63.4-2014 chapter 8.3, ANSI C63.10-2013 chapter 6.6.3.3 & 6.6.4

General Description: Evaluating the emissions have to be done first by an exploratory emissions measurement and a final measurement for most critical frequencies. The tests are performed in a CISPR 16-1-4:2010 compliant fully anechoic room (FAR) recognized by the regulatory commission. The measurement distance was set to 3 meter for frequencies up to 18 GHz and 2 meter above 18 GHz. A logarithmic periodic antenna is used for the frequency range 30 MHz to 1 GHz. Horn antennas are used for frequency range 1 GHz to 40 GHz. The EUT is aligned within 3 dB beam width of the measurement antenna with three orthogonal axis measurements on the EUT.

Schematic:

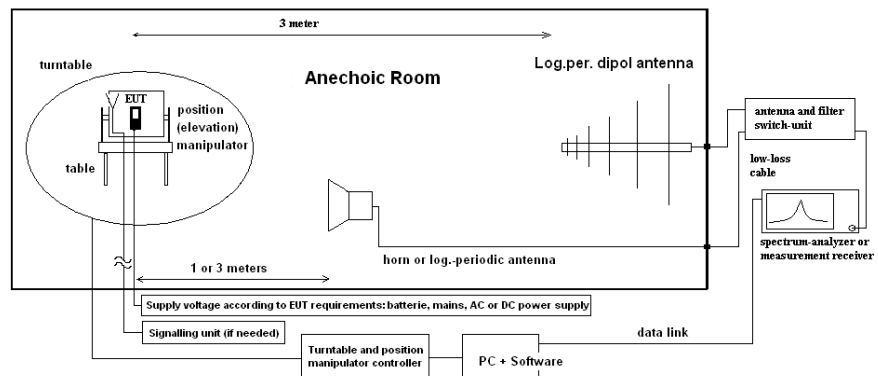

Testing method:

Exploratory, preliminary measurements

The EUT and its associated accessories are placed on a non-conductive position manipulator (tipping device) of 1.55 m height which is placed on the turntable. By rotating the turntable (range 0° to 360°, step 15°) and the EUT itself either on 3-orthogonal axis (portable equipment) or 2-orthogonal axis (defined operational position of EUT) the emission spectrum and its characteristics was recorded with an EMI-receiver, broadband antenna and software. The measurements are performed in horizontal and vertical polarization of the measurement antennas. The results are documented in a diagram. Critical frequencies (low margin to limit) are saved within a table for further investigations. If various operating modes are supported, further investigations are made to find the worst-case of them. Also the interconnection cables and equipment position were varied in order to maximize the emissions.

Final measurement on critical frequencies

Based on the exploratory measurements, the most critical frequencies are re-measured by maintaining the EUT's worst-case operation mode, cable position, etc.

First a frequency zoom around the critical frequency is done to locate the frequency more precisely. After this step, for all identified critical frequencies, the maximum peak was determined. Following parameters were varied: the turntable angle continuously in the range 0 to 360 degree, the EUT itself over 3-orthogonal axis and the height for EUT with large dimensions.

On the determined worst-case position, a final measurement with necessary bandwidth and detector according standard has been carried out. On the determined worst-case position, a final measurement with necessary bandwidth and detector according standard has been carried out.

Formula:

$$E_C = E_R + AF + C_L + D_F - G_A \quad (1)$$

$$M = L_T - E_C \quad (2)$$

E_C = Electrical field – corrected value

E_R = Receiver reading

M = Margin

L_T = Limit

AF = Antenna factor

C_L = Cable loss

D_F = Distance correction factor (if used)

G_A = Gain of pre-amplifier (if used)

All units are dB-units, positive margin means value is below limit.

5. Measurements

5.1. Duty-Cycle

5.1.1. Test location and equipment (for reference numbers please see chapter 'List of test equipment')

| Ambient Climatic conditions | | Temperature: (22±2)°C | | Rel. humidity: (45±15)% | | |
|-----------------------------|---|--|---|--|--|--------------------------------------|
| Test Site | <input type="checkbox"/> 441 EMI SAR | <input type="checkbox"/> 348 EMI cond. | <input type="checkbox"/> 443 EMI FAR | <input checked="" type="checkbox"/> 347 Radio.lab. | <input type="checkbox"/> 337 OATS | <input type="checkbox"/> |
| Equipment | <input type="checkbox"/> 331 HC 4055 | <input type="checkbox"/> | <input type="checkbox"/> | <input checked="" type="checkbox"/> 693 TS8997 | <input type="checkbox"/> | <input type="checkbox"/> |
| Spectr. Analys. | <input checked="" type="checkbox"/> 683 FSU26 | <input type="checkbox"/> 120 FSEM | <input type="checkbox"/> 264 FSEK | <input checked="" type="checkbox"/> 693 TS8997 | <input type="checkbox"/> | <input type="checkbox"/> |
| Power Meter | <input type="checkbox"/> 262 NRV-S | <input type="checkbox"/> 266 NRV-Z31 | <input type="checkbox"/> 265 NRV-Z33 | <input type="checkbox"/> 261 NRV-Z55 | <input type="checkbox"/> 356 NRV-Z1 | <input type="checkbox"/> |
| Multimeter | <input type="checkbox"/> 341 Fluke 112 | <input type="checkbox"/> | <input type="checkbox"/> | <input type="checkbox"/> | <input type="checkbox"/> | <input type="checkbox"/> |
| DC Power | <input type="checkbox"/> 086 LNG50-10 | <input checked="" type="checkbox"/> 087 EA3013 | <input type="checkbox"/> 354 NGPE 40 | <input type="checkbox"/> 349 car battery | <input type="checkbox"/> 350 Car battery | <input type="checkbox"/> 463 HP3245A |
| Supply Voltage | <input type="checkbox"/> 230 V 50 Hz via public mains | | <input checked="" type="checkbox"/> 15 V DC | | | |
| Otherwise | <input checked="" type="checkbox"/> 530 Attenuator 10dB | <input checked="" type="checkbox"/> K4 Cable | | | | |

Method of measurement: conducted
 radiated

A special firmware program is used for test purposes. In contrast to normal operating mode a higher duty-cycle is set in order to facilitate the measurements. This is maximized at the extent possible.

The necessary duty-cycle correction factor is determined on nominal conditions on 1 channel for all sub-bands. It is assumed that no noticeable changes occur when tested on other channels or climatic conditions.

Calculated with following formulas:

| | | | |
|-------------|---|-------------------------|--------------------------------------|
| Duty cycle: | $x = \frac{T_{x_{on}}}{T_{x_{on}} + T_{x_{off}}}$ | Duty cycle factor [dB]: | $10 \log \left(\frac{1}{x} \right)$ |
|-------------|---|-------------------------|--------------------------------------|

Results:

| | |
|-------------|---|
| Set-up No.: | 2 |
| Op. Mode: | 1 |

| DUTY-CYCLE Measurement | | | | | | | | |
|--|------------|-------------|-------------|---------------------------------|----------------------------------|---------------|--|------------|
| WLAN 5 GHz | Marker 1 | Marker 2 | Marker 3 | TX ON Marker 2 - Marker 1 | TX OFF Marker 3 - Marker 2 | Duty Cycle | Correction- Factor: 100log(1/DC) | Plot No. |
| Data Rate | ms | ms | ms | ms | ms | (%) | (dB) | (Remark 1) |
| WLAN 5 GHz a-Mode Ch 36 (5180 MHz) | | | | | | | | |
| 6MBit | 1,561538 | 3,632128 | 5,816000 | 2,07059 | 2,18387 | 48,67 | 3,13 | 1 |
| WLAN 5 GHz n(HT20)-Mode Ch 36 (5180 MHz) | | | | | | | | |
| MCS0 | 2,134615 | 4,083333 | 6,451923 | 1,94872 | 2,36859 | 45,14% | 3,45 | 4 |
| WLAN 5 GHz n(HT40)-Mode Ch 38 Ch 62 Ch 102 Ch 151 | | | | | | | | |
| MCS1 | 391,410000 | 1388,000000 | 1394,000000 | 996,59000 | 6,00000 | 99,40% | 0,03 | 8 |
| MCS3 | 542,051282 | 1235,642000 | 1545,256000 | 693,59072 | 309,61400 | 69,14% | 1,60 | 9 |
| MCS1 | 173,461538 | 1170,051000 | 1176,667000 | 996,58946 | 6,61600 | 99,34% | 0,03 | 8 |
| MCS5 | 519,615385 | 1516,205000 | 1522,821000 | 996,58962 | 6,61600 | 99,34% | 0,03 | 9 |
| WLAN 5 GHz ac(HT20)-Mode Ch 36 (5180 MHz) | | | | | | | | |
| MCS0 | 0,929487 | 2,873397 | 6,080929 | 1,94391 | 3,20753 | 37,74% | 4,23 | 4 |
| WLAN 5 GHz ac(HT40)-Mode Ch 42 (5190 MHz) | | | | | | | | |
| MCS6 | 381,794872 | 1388,000000 | 1391,410000 | 1006,20513 | 3,41000 | 99,66% | 0,01 | 8 |
| WLAN 5 GHz ac(HT80)-Mode Ch 42 (5190 MHz) | | | | | | | | |
| MCS0 | 0,666667 | 1,130154 | 5,820513 | 0,46349 | 4,69036 | 8,99% | 10,46 | 8 |

Remark 1: For further details please refer → Annex 1: Test results CETECOM_TR17-1-00659T60a-A1

- The results were corrected in order to evaluate for worst-case result each time when average values are necessary for example average radiated emissions or similar
- No correction necessary: Duty-Cycle > 98%

5.2. RF-Parameter - Transmitter Peak output power (conducted and radiated)

5.2.1. Test location and equipment (for reference numbers please see chapter 'List of test equipment')

| | | | |
|-----------------|--|--|--|
| test location | <input checked="" type="checkbox"/> CETECOM Essen (Chapter. 2.2.1) | <input type="checkbox"/> 443 System CTC-FAR-EMI- | <input type="checkbox"/> Please see Chapter. 2.2.3 |
| test site | <input type="checkbox"/> 441 EMI SAR | <input type="checkbox"/> 487 SAR NSA | <input type="checkbox"/> 337 OATS |
| receiver | <input type="checkbox"/> 377 ESCS30 | <input type="checkbox"/> 001 ESS | <input checked="" type="checkbox"/> 347 Radio.lab. |
| otherwise | <input checked="" type="checkbox"/> 600 NRVD | <input checked="" type="checkbox"/> 357 NRV-Z1 | <input checked="" type="checkbox"/> 620 ESU 26 |
| spectr. analys. | <input type="checkbox"/> 215 FSU | <input type="checkbox"/> 120 FSEM | <input type="checkbox"/> 264 FSEK |
| power supply | <input type="checkbox"/> 456 EA 3013A | <input checked="" type="checkbox"/> 457 EA 3013A | <input type="checkbox"/> 459 EA 2032-50 |
| otherwise | <input checked="" type="checkbox"/> 613 20 dB Attenuator | <input type="checkbox"/> 248 6 dB Attenuator | <input type="checkbox"/> 529 Power divider |
| Supply voltage | <input type="checkbox"/> 230 V 50 Hz via public mains | <input checked="" type="checkbox"/> 15 V DC | <input type="checkbox"/> - cable OTA20 |

5.2.2. Reference:

| | |
|-------------------------|---|
| FCC | <input checked="" type="checkbox"/> Part 15 Subpart C, §15.407(a)(1)(2)(3)(4) |
| ANSI | <input checked="" type="checkbox"/> C63.10-2013 |
| KDB Guidance no. | <input checked="" type="checkbox"/> KDB 789033 D02 General UNII Test Procedures New Rules v01r04: Subchapter E, <u>Method PM (3)(a)</u> <input type="checkbox"/> KDB 662911 D01 Multiple Transmitter Output v02r01 (MIMO, Smart-antenna) |
| Limits | <p><input checked="" type="checkbox"/> Frequency Band 5150 – 5250 MHz</p> <p><input type="checkbox"/> Outdoor access point: maximum conducted power shall not exceed 1 W if Antenna Gain < 6 dBi if Antenna Gain > 6 dBi maximum conducted output power shall be reduced by the amount in dB that the directional gain of the antenna exceeds 6 dBi</p> <p><input type="checkbox"/> Indoor access point: maximum conducted power shall not exceed 1 W if Antenna Gain < 6 dBi if Antenna Gain > 6 dBi maximum conducted output power shall be reduced by the amount in dB that the directional gain of the antenna exceeds 6 dBi</p> <p><input type="checkbox"/> Fixed point to point access point: maximum conducted power shall not exceed 1 W if Antenna Gain < 6 dBi if Antenna Gain > 6 dBi maximum conducted output power shall be reduced by the amount in dB that the directional gain of the antenna exceeds 6 dBi</p> <p><input checked="" type="checkbox"/> Client devices: maximum conducted power shall not exceed 250 mW if Antenna Gain < 6 dBi if Antenna Gain > 6 dBi maximum conducted output power shall be reduced by the amount in dB that the directional gain of the antenna exceeds 6 dBi</p> <hr/> <p><input checked="" type="checkbox"/> Frequency Band 5250 – 5350 MHz <input checked="" type="checkbox"/> Frequency bands 5470- 5725 MHz</p> <p><input checked="" type="checkbox"/> All Devices: maximum conducted power lesser of 250 mW or $11 + 10 \log_{10}B$, dBm (B:26 dB emission B.W. in MHz)</p> <hr/> <p><input checked="" type="checkbox"/> Frequency band 5725-5850 MHz</p> <p><input checked="" type="checkbox"/> All Devices: maximum conducted power shall not exceed 1 W if Antenna Gain < 6 dBi if Antenna Gain > 6 dBi maximum conducted output power shall be reduced by the amount in dB that the directional gain of the antenna exceeds 6 dBi</p> |

5.2.3. Antenna characteristics:

- directional gain < 6 dBi (Applicants declaration)
- directional gain > 6 dBi (measured / applicant’s declaration) -> conducted power reduction necessary

5.2.4. EUT settings:

The EUT was instructed to send with maximum power (if adjustable) according applicants instructions.

5.2.5. Measurement method:

| Method used | Reference to KDB | Remarks: |
|---|---|---|
| <input type="checkbox"/> SA | KDB 789033 D02 General UNII Test Procedures New Rules v01r04 | Integration bandwidth method |
| <input checked="" type="checkbox"/> Power Meter | a.) Method PM | A wideband thermocouple RF-power meter as described by KDB was used. <input checked="" type="checkbox"/> Duty-Cycle correction necessary <input type="checkbox"/> A value correction is not necessary since the EUT is transmitting continuously at duty-cycle > 98%. |

5.2.6. Conducted power measurement and EIRP calculations

• Applicant’s declared Maximum Directional Antenna Peak Gain :

- U-NII 1: 7.10dBi
- U-NII 2: 5.80dBi
- U-NII 2C: 2.31dBi
- U-NII 3: 1.03dBi

| | |
|-------------|--|
| Set-up No.: | 2 |
| Op. Mode: | 1 (WLAN 5 GHz a Mode B.W. 20 MHz Power Settings: 10) |

| Operational bands: | U-NII 1 | | | U-NII-2A | | | U-NII-2C | | | U-NII-3 | | |
|--------------------|----------------------|----------------------|----------------------|----------------------|----------------------|----------------------|-----------------------|-----------------------|-----------------------|-----------------------|-----------------------|-----------------------|
| Channel no.: | Channel 36 (5180MHz) | Channel 40 (5200MHz) | Channel 48 (5240MHz) | Channel 52 (5260MHz) | Channel 56 (5280MHz) | Channel 64 (5320MHz) | Channel 100 (5500MHz) | Channel 116 (5580MHz) | Channel 140 (5700MHz) | Channel 149 (5745MHz) | Channel 157 (5785MHz) | Channel 165 (5825MHz) |
| a-Mode | | | | | | | | | | | | |
| 6Mbit | 7,9 | 7,9 | 8,1 | 8,2 | 8,3 | 8,4 | 8,8 | 9 | 9,2 | 9,4 | 9,5 | 9,7 |
| 9Mbit | 7,8 | 7,8 | 8 | 8,1 | 8,1 | 8,3 | 8,7 | 8,9 | 9,1 | 9,2 | 9,4 | 9,5 |
| 12Mbit | 7,8 | 8,1 | 8,1 | 8,1 | 8,2 | 8,3 | 8,8 | 8,9 | 9,2 | 9,3 | 9,4 | 9,6 |
| 18Mbit | 7,8 | 8,1 | 8 | 8,1 | 8,2 | 8,3 | 8,8 | 8,9 | 9,2 | 9,3 | 9,4 | 9,6 |
| 24Mbit | 7,8 | 8 | 8,1 | 8,1 | 8,2 | 8,3 | 8,8 | 8,9 | 9,2 | 9,3 | 9,4 | 9,6 |
| 36Mbit | 7,8 | 8,1 | 8 | 8,1 | 8,2 | 8,3 | 8,8 | 8,9 | 9,1 | 9,3 | 9,4 | 9,6 |
| 48Mbit | 7,8 | 8 | 8,1 | 8,1 | 8,2 | 8,3 | 8,8 | 8,9 | 9,2 | 9,3 | 9,4 | 9,6 |
| 54Mbit | 7,9 | 8,1 | 8,1 | 8,1 | 8,2 | 8,3 | 8,8 | 8,9 | 9,2 | 9,3 | 9,5 | 9,6 |

| Operational bands: | U-NII 1 | | | U-NII-2A | | | U-NII-2C | | | U-NII-3 | | |
|----------------------------------|---------|--|--|----------|--|--|----------|--|--|---------|--|--|
| FCC-Limits conducted power [dBm] | 22,90 | | | 24,00 | | | 24,00 | | | 30,00 | | |
| FCC-Limits EIRP [dBm] | 30,00 | | | 30,00 | | | 30,00 | | | 36,00 | | |

| Limit Check: | Limit Check: | | | | | | | | | | | |
|--|--------------|--|--|-------|--|--|-------|--|--|-------|--|--|
| Highest conducted power value over channels and modulations: | 8,1 | | | 8,4 | | | 9,2 | | | 9,7 | | |
| Margin to Limit conducted power: | 14,80 | | | 15,60 | | | 14,80 | | | 20,30 | | |
| Declared antenna Gain: | 7,10 | | | 5,80 | | | 2,31 | | | 1,03 | | |
| Peak EIRP | 15,20 | | | 14,20 | | | 11,51 | | | 10,73 | | |
| Margin to Limit EIRP | 14,80 | | | 15,80 | | | 18,49 | | | 25,27 | | |
| Verdict: | pass | | | pass | | | pass | | | pass | | |

Remark : Please refer Chapter 5.1 for applicable Duty-Cycle Correction Factor

| | |
|-------------|--|
| Set-up No.: | 2 |
| Op. Mode: | 1 (WLAN 5 GHz n Mode B.W. 20 MHz Power Settings: 10) |

| Operational bands: | U-NII 1 | | | U-NII-2A | | | U-NII-2C | | | U-NII-3 | | |
|--|-------------------------|-------------------------|-------------------------|-------------------------|-------------------------|-------------------------|--------------------------|--------------------------|--------------------------|--------------------------|--------------------------|--------------------------|
| Channel no.: | Channel 36 (5180MHz) | Channel 40 (5200MHz) | Channel 48 (5240MHz) | Channel 52 (5260MHz) | Channel 56 (5280MHz) | Channel 64 (5320MHz) | Channel 100 (5500MHz) | Channel 116 (5580MHz) | Channel 140 (5700MHz) | Channel 149 (5745MHz) | Channel 157 (5785MHz) | Channel 165 (5825MHz) |
| n-Mode | | | | | | | | | | | | |
| MCS0 - 6.5Mbps | 6,6 | 6,7 | 6,9 | 7,2 | 7,3 | 7,9 | 7,6 | 7,3 | 6,8 | 6,8 | 7 | 7 |
| MCS1 - 13Mbps | 6,4 | 6,4 | 6,6 | 7 | 7,4 | 7,6 | 7,3 | 7 | 6,9 | 6,6 | 6,9 | 6,6 |
| MCS2 - 19.5Mbps | 6,1 | 6,3 | 6,6 | 7 | 7,3 | 7,5 | 7,2 | 7,3 | 6,9 | 6,7 | 6,9 | 6,7 |
| MCS3 - 26Mbps | 6,1 | 6,1 | 6,5 | 7 | 7,3 | 7,5 | 7,3 | 7,2 | 6,8 | 6,7 | 6,9 | 6,7 |
| MCS4 - 39Mbps | 6,2 | 6,2 | 6,6 | 6,9 | 7,4 | 7,6 | 7,2 | 7,2 | 6,9 | 6,7 | 6,9 | 6,7 |
| MCS5 - 52Mbps | 6,2 | 6,6 | 6,5 | 7,1 | 7,4 | 7,5 | 7,3 | 6,8 | 6,8 | 6,9 | 7 | 6,7 |
| MCS6 - 58.5Mbps | 6,2 | 6,3 | 6,6 | 7,1 | 7,4 | 7,6 | 7,3 | 6,8 | 6,8 | 6,8 | 7 | 6,7 |
| MCS7 - 65Mbps | 6,2 | 6,1 | 6,6 | 7 | 7,4 | 7,5 | 7,2 | 6,8 | 6,8 | 6,7 | 7 | 6,7 |
| Operational bands: | U-NII 1 | | | U-NII-2A | | | U-NII-2C | | | U-NII-3 | | |
| FCC Limits conducted power [dBm] | 22,90 | | | 24,00 | | | 24,00 | | | 30,00 | | |
| FCC Limits EIRP [dBm] | 30,00 | | | 30,00 | | | 30,00 | | | 36,00 | | |
| Limit Check: | Limit Check: | | | | | | | | | | | |
| Highest conducted power value over channels and modulations: | 6,9 | | | 7,9 | | | 7,6 | | | 7,0 | | |
| Margin to Limit conducted power: | 16,00 | | | 16,10 | | | 16,40 | | | 23,00 | | |
| Declared antenna Gain: | 7,10 | | | 5,80 | | | 2,31 | | | 1,03 | | |
| Peak EIRP | 14,00 | | | 13,70 | | | 9,91 | | | 8,03 | | |
| Margin to Limit EIRP | 16,00 | | | 16,30 | | | 20,09 | | | 27,97 | | |
| Verdict: | pass | | | pass | | | pass | | | pass | | |

Remark : Please refer Chapter 5.1 for applicable Duty-Cycle Correction Factor

| | |
|-------------|--|
| Set-up No.: | 2 |
| Op. Mode: | 1 (WLAN 5 GHz n Mode B.W. 40 MHz Power Settings: 10) |

| Operational bands: | U-NII 1 | | U-NII-2A | | U-NII 2C | | U-NII-3 | | |
|---|-------------------------|-------------------------|-------------------------|-------------------------|--------------------------|--------------------------|--------------------------|--------------------------|--------------------------|
| Channel no.: | Channel 38 (5190MHz) | Channel 46 (5230MHz) | Channel 54 (5270MHz) | Channel 62 (5310MHz) | Channel 102 (5550MHz) | Channel 118 (5590MHz) | Channel 134 (5670MHz) | Channel 151 (5755MHz) | Channel 159 (5815MHz) |
| HT40: n-Mode | | | | | | | | | |
| MCS0 | 4,8 | 5,3 | 5,4 | 6,1 | 7,9 | 7,9 | 7,4 | 6,8 | 6,9 |
| MCS1 | 4,9 | 5,4 | 5,5 | 6,1 | 8 | 7,9 | 7,5 | 6,8 | 6,5 |
| MCS2 | 4,9 | 5,4 | 5,5 | 6,1 | 8 | 8 | 7,5 | 6,8 | 6,5 |
| MCS3 | 4,9 | 5 | 5,6 | 6,2 | 8 | 7,9 | 7,6 | 6,8 | 6,5 |
| MCS4 | 4,9 | 5 | 5,6 | 6,2 | 8 | 7,9 | 7,6 | 6,8 | 6,5 |
| MCS5 | 4,9 | 5,4 | 5,5 | 6,2 | 8 | 8 | 7,5 | 6,9 | 6,6 |
| MCS6 | 4,9 | 5,4 | 5,5 | 6,2 | 7,9 | 8 | 7,5 | 6,9 | 6,6 |
| MCS7 | 4,9 | 5,4 | 5,5 | 6,2 | 8 | 8 | 7,5 | 6,9 | 6,6 |
| maximum | 5,4 | | 6,2 | | 8 | | 6,9 | | |
| worst case | MCS1 | | MCS3 | | MCS1 | | MCS5 | | |
| Operational bands: | U-NII 1 | | U-NII-2A | | U-NII 2C | | U-NII-3 | | |
| FCC-Limits output power [dBm] | 22,90 | | 24,00 | | 24,00 | | 30 | | |
| FCC-Limits EIRP [dBm] | 30,00 | | 30,00 | | 30,00 | | 36 | | |
| Limit Check: | Limit Check: | | | | | | | | |
| Highest conducted power value over channels and | 5,4 | | 6,2 | | 8,0 | | 6,9 | | |
| Margin to Limit output power: | 17,50 | | 17,80 | | 16,00 | | 23,1 | | |
| Declared antenna Gain: | 7,10 | | 5,80 | | 2,31 | | 1,03 | | |
| Peak EIRP | 12,50 | | 12,00 | | 10,31 | | 7,93 | | |
| Margin to Limit EIRP: | 17,50 | | 18,00 | | 19,69 | | 28,07 | | |
| Verdict: | pass | | pass | | pass | | pass | | |

Remark : Please refer Chapter 5.1 for applicable Duty-Cycle Correction Factor

Remark : Please refer Chapter 5.1 for applicable Duty-Cycle Correction Factor

| | |
|-------------|--|
| Set-up No.: | 2 |
| Op. Mode: | 1 (WLAN 5 GHz ac Mode B.W. 20 MHz Power Settings: 6) |

| Operational bands: | U-NII 1 | | | U-NII-2A | | | U-NII 2C | | | U-NII-3 | | |
|--|----------------------|----------------------|----------------------|----------------------|----------------------|----------------------|-----------------------|-----------------------|-----------------------|-----------------------|-----------------------|-----------------------|
| Channel no.: | Channel 36 (5180MHz) | Channel 40 (5200MHz) | Channel 48 (5240MHz) | Channel 52 (5260MHz) | Channel 56 (5280MHz) | Channel 64 (5320MHz) | Channel 100 (5500MHz) | Channel 116 (5580MHz) | Channel 140 (5700MHz) | Channel 149 (5745MHz) | Channel 157 (5785MHz) | Channel 165 (5825MHz) |
| ac-Mode/6dBm | | | | | | | | | | | | |
| MCS0 | 0,9 | 0,9 | 1,4 | 1,5 | 1,6 | 2,5 | 4,2 | 3,9 | 3,5 | 3,3 | 3,1 | 2,9 |
| MCS1 | 1,1 | 0,9 | 1,4 | 1,5 | 1,7 | 2 | 3,7 | 3,9 | 3,6 | 2,8 | 2,8 | 2,3 |
| MCS2 | 1,1 | 0,9 | 1,3 | 1,6 | 1,7 | 2,1 | 3,7 | 4 | 3,6 | 2,9 | 2,8 | 2,4 |
| MCS3 | 1,2 | 1 | 1 | 1,6 | 1,7 | 2,1 | 3,7 | 4 | 3,3 | 2,9 | 2,9 | 2,4 |
| MCS4 | 1,1 | 1 | 1,1 | 1,6 | 1,8 | 2,1 | 3,7 | 4 | 3,3 | 2,9 | 2,9 | 2,4 |
| MCS5 | 0,7 | 1,1 | 1 | 1,6 | 1,3 | 2,1 | 3,7 | 4 | 3,2 | 3 | 2,9 | 2,5 |
| MCS6 | 0,9 | 1,1 | 1 | 1,6 | 1,3 | 2,1 | 3,7 | 4 | 3,3 | 3 | 2,8 | 2,5 |
| MCS7 | 1 | 1,1 | 1 | 1,6 | 1,3 | 2,1 | 3,6 | 4 | 3,4 | 3 | 2,9 | 2,5 |
| MCS8 | 0,9 | 1 | 1 | 1,6 | 1,4 | 2,1 | 3,7 | 3,9 | 3,3 | 2,9 | 2,8 | 2,4 |
| MCS9 | 1,2 | 1,1 | 1,4 | 1,6 | 1,8 | 2,5 | 4,2 | 4 | 3,6 | 3,3 | 3,1 | 2,9 |
| Operational bands: | U-NII 1 | | | U-NII-2A | | | U-NII 2C | | | U-NII 2C | | |
| FCC-Limits output power [dBm] | 22,90 | | | 24,00 | | | 24,00 | | | 30,00 | | |
| FCC-Limits EIRP [dBm] | 30,00 | | | 30,00 | | | 30,00 | | | 36,00 | | |
| Limit Check: | Limit Check: | | | | | | | | | | | |
| Highest conducted power value over channels and modulations: | 1,4 | | | 2,5 | | | 4,2 | | | 3,3 | | |
| Margin to Limit output power: | 21,50 | | | 21,50 | | | 19,80 | | | 26,70 | | |
| Declared antenna Gain: | 7,10 | | | 5,80 | | | 2,31 | | | 1,03 | | |
| Peak EIRP | 8,50 | | | 8,30 | | | 6,51 | | | 4,33 | | |
| Margin to Limit EIRP: | 21,50 | | | 21,70 | | | 23,49 | | | 31,67 | | |
| Verdict: | pass | | | pass | | | pass | | | pass | | |

Remark : Please refer Chapter 5.1 for applicable Duty-Cycle Correction Factor

| | | | | | | | | | | |
|--|--|-------------------------|-------------------------|-------------------------|--------------------------|--------------------------|--------------------------|--------------------------|--------------------------|--|
| Set-up No.: | 2 | | | | | | | | | |
| Op. Mode: | 1 (WLAN 5 GHz ac Mode B.W. 40 MHz Power Settings: 6) | | | | | | | | | |
| Operational bands: | U-NII 1 | | U-NII-2A | | U-NII 2C | | | U-NII-3 | | |
| Channel no.: | Channel 38 (5190MHz) | Channel 46 (5230MHz) | Channel 54 (5270MHz) | Channel 62 (5310MHz) | Channel 102 (5550MHz) | Channel 118 (5590MHz) | Channel 134 (5670MHz) | Channel 151 (5755MHz) | Channel 159 (5815MHz) | |
| HT40: AC-Mode/6dBm | 38 | 46 | 54 | 62 | 102 | 118 | 134 | 151 | 159 | |
| MCS0 | 2,2 | 2,4 | 2,5 | 2,7 | 3,1 | 3,1 | 3,5 | 3,7 | 3,9 | |
| MCS1 | 2,3 | 2,5 | 2,6 | 2,6 | 3,1 | 3,3 | 3,5 | 3,7 | 3,9 | |
| MCS2 | 2,3 | 2,4 | 2,6 | 2,7 | 3,1 | 3,3 | 3,5 | 3,7 | 3,9 | |
| MCS3 | 2,3 | 2,5 | 2,6 | 2,6 | 3,2 | 3,8 | 4 | 4,3 | 4,4 | |
| MCS4 | 2,9 | 3 | 3,1 | 3,3 | 3,7 | 3,8 | 4 | 4,4 | 4,4 | |
| MCS5 | 2,9 | 2,9 | 3,1 | 3,2 | 3,8 | 3,9 | 4 | 4,3 | 4,4 | |
| MCS6 | 2,9 | 3 | 3,1 | 3,3 | 3,7 | 3,9 | 4 | 4,2 | 4,5 | |
| MCS7 | 2,9 | 3 | 3,1 | 3,2 | 3,7 | 3,9 | 4 | 4,3 | 4,4 | |
| MCS8 | 2,8 | 3 | 3,1 | 3,2 | 3,8 | 3,8 | 4 | 4,3 | 4,4 | |
| MCS9 | 2,9 | 3 | 3,1 | 3,3 | 3,7 | 3,8 | 4 | 4,3 | 4,5 | |
| Operational bands: | U-NII 1 | | U-NII-2A | | U-NII 2C | | | U-NII-3 | | |
| FCC-Limits [dBm] | 22,90 | | 24,00 | | 24,00 | | | 30 | | |
| FCC-Limits [dBm] | 30,00 | | 30,00 | | 30,00 | | | 36 | | |
| Limit Check: | Limit Check: | | | | | | | | | |
| Highest conducted power value over channels and modulations: | 3 | | 3,3 | | 4,0 | | | 4,5 | | |
| Margin to Limit output power: | 19,90 | | 20,70 | | 20,00 | | | 25,5 | | |
| Declared antenna Gain: | 7,10 | | 5,80 | | 2,31 | | | 1,03 | | |
| Peak EIRP | 10,10 | | 9,10 | | 6,31 | | | 5,53 | | |
| Margin to Limit EIRP | 19,90 | | 20,90 | | 23,69 | | | 30,47 | | |
| Verdict: | pass | | pass | | pass | | | pass | | |

Remark : Please refer Chapter 5.1 for applicable Duty-Cycle Correction Factor

| | | | | | |
|---|--|-------------------------|--------------------------|--------------------------|--------------------------|
| Set-up No.: | 2 | | | | |
| Op. Mode: | 1 (WLAN 5 GHz ac Mode B.W. 80 MHz Power Settings: 6) | | | | |
| HT80: AC-Mode/6dBm | U-NII 1 | U-NII-2A | U-NII 2C | | U-NII-3 |
| Channel no.: | Channel 42 (5210MHz) | Channel 58 (5290MHz) | Channel 106 (5530MHz) | Channel 122 (5610MHz) | Channel 155 (5775MHz) |
| MCS0 | 8,7 | 9 | 9,5 | 9,6 | 10,1 |
| MCS1 | 8,1 | 8,4 | 8,9 | 9 | 9,4 |
| MCS2 | 8,1 | 8,4 | 9 | 9,1 | 9,5 |
| MCS3 | 8 | 8,3 | 8,9 | 9 | 9,4 |
| MCS4 | 8,2 | 8,4 | 9,1 | 9,2 | 9,6 |
| MCS5 | 8 | 8,3 | 8,9 | 9 | 9,5 |
| MCS6 | 8,1 | 8,4 | 9 | 9,1 | 9,5 |
| MCS7 | 8,1 | 8,3 | 8,9 | 9,1 | 9,5 |
| MCS8 | 8,1 | 8,3 | 8,9 | 9 | 9,5 |
| MCS9 | 8,1 | 8,3 | 8,9 | 9 | 9,5 |
| Operational bands: | U-NII 1 | U-NII-2A | U-NII 2C | | U-NII-3 |
| FCC-Limits output power [dBm] | 22,90 | 24,00 | 24,00 | | 30 |
| FCC-Limits EIRP [dBm] | 30,00 | 30,00 | 30,00 | | 36 |
| Limit Check: | Limit Check: | | | | |
| Highest conducted power value over channels and modulations: | 8,7 | 9,0 | 9,6 | | 10,1 |
| Margin to Limit output power: | 14,20 | 15,00 | 14,40 | | 19,9 |
| Declared antenna Gain: | 7,10 | 5,80 | 2,31 | | 1,03 |
| Peak EIRP | 15,80 | 14,80 | 11,91 | | 11,13 |
| Margin to Limit EIRP: | 14,20 | 15,20 | 18,09 | | 24,87 |
| Verdict: | pass | pass | pass | | pass |

Remark : Please refer Chapter 5.1 for applicable Duty-Cycle Correction Factor

5.2.7. Verdict: Pass

5.3. RF Parameter - 26 dB and 99% occupied Bandwidth

5.3.1. Test location and equipment (for reference numbers please see chapter 'List of test equipment')

| | | | | | | |
|-----------------|---|--|---|--|-----------------------------------|--------------------------|
| test site | <input type="checkbox"/> 441 EMI SAR | <input type="checkbox"/> 348 EMI cond. | <input type="checkbox"/> 443 EMI FAR | <input checked="" type="checkbox"/> 347 Radio.lab. | <input type="checkbox"/> 337 OATS | <input type="checkbox"/> |
| spectr. analys. | <input type="checkbox"/> 584 FSU | <input type="checkbox"/> 120 FSEM | <input type="checkbox"/> 264 FSEK | <input checked="" type="checkbox"/> 489 ESU | <input type="checkbox"/> | <input type="checkbox"/> |
| attenuator | <input checked="" type="checkbox"/> 530 10 dB | <input type="checkbox"/> | <input type="checkbox"/> | <input type="checkbox"/> | <input type="checkbox"/> | <input type="checkbox"/> |
| signaling | <input type="checkbox"/> 392 MT8820A | <input type="checkbox"/> 436 CMU | <input type="checkbox"/> 547 CMU | | | |
| DCpower | <input type="checkbox"/> 463 Power source | <input type="checkbox"/> 087 EA3013 | <input checked="" type="checkbox"/> 354 NGPE 40 | <input type="checkbox"/> 086 LNG50-10 | <input type="checkbox"/> | <input type="checkbox"/> |
| line voltage | <input type="checkbox"/> 230 V 50 Hz via public mains | | <input type="checkbox"/> 15V DC | | | |

5.3.2. Test condition and measurement test set-up

| | | | |
|--------------------------------|-----------------------------------|--|--------------------------|
| link to test system (if used): | <input type="checkbox"/> air link | <input checked="" type="checkbox"/> cable connection | <input type="checkbox"/> |
| Climatic conditions | Temperature: (22±3°C) | | Rel. humidity: (40±20)% |

5.3.3. References of occupied and emission bandwidth

| | |
|------------------|--|
| FCC | <input checked="" type="checkbox"/> FCC 2.202 for information <input checked="" type="checkbox"/> Part 15 Subpart C, §15.407(e) |
| ISED | RSS-Gen, Issue 4, chapter 4.6.1 RSS-247, Issue 2 |
| ANSI | <input checked="" type="checkbox"/> C63.10-2013 |
| KDB Guidance no. | <input checked="" type="checkbox"/> 789033 D02 General UNII test procedures v01r04, Subchapter C |
| Limits | <input checked="" type="checkbox"/> necessary for maximum power limits depending of B <input checked="" type="checkbox"/> FCC/ISED: decision if DFS necessary for decision if due 26dBc emissions falling in 5250-5350MHz band <input checked="" type="checkbox"/> FCC §15.407(e)/ISED: minimum 500kHz for band 5725-5850MHz |

5.3.4. EUT Settings:

The EUT was instructed to send with different power/ data rates (if adjustable) according applicants instructions. Different modulation characteristics have been checked, e.g. data rates which EUT can operate.

5.3.5. Measurement method:

The measurement was performed with the RBW set to approximately 1% of the emission bandwidth. The span was set to cover the complete carrier. Three carrier frequencies were used for showing the compliance with this requirement. A DELTA Marker method was set to measure the bandwidth compared to the highest In-Band power. The operating modes have been varied for **26 dB bandwidth** (e.g. data rate, modulation scheme, etc.).

Also the **99% occupied bandwidth** was measured. Two markers are placed on frequency points such that left to lower f-marker and right to higher f-marker only 1% of the TX-power is contained. Between the markers, 99% of the power is laying. The RBW value is readjusted and the measurement repeated until the RBW/EBW ratio is around 1%. The operating modes have been taken the maximum data rates, which had been found out at the output power conducted measurements.

5.3.6. Spectrum-Analyzer Settings: (check if accord. KDB)

| | |
|----------------------------|---|
| Span | Set as to fully display the emissions and at least 26 dB below the PEAK level |
| Resolution Bandwidth (RBW) | Set to approx 1% |
| Video Bandwidth (VBW) | 3 times the resolution bandwidth |
| Sweep time | Coupled and low enough to have no gaps within power envelope |
| Detector | PK (26 dB BW)/Sample (99% OBW) |
| Sweep mode | Repetitive Mode, MAX-HOLD |

5.3.7. Results:

| Set-up no.: | 2 | | | | |
|-------------|--|-------------------|-----------------------|------------------------------|-------------|
| Op. Mode: | 1 (WLAN 5 GHz a Mode B.W. 20 MHz Power Settings: 10) | | | | |
| | Channel No. | Nominal bandwidth | 26 dB Bandwidth [MHz] | 99% Occupied Bandwidth [MHz] | Diagram no. |
| UN-II-1 | 48 | 20 | 20.2 | 16.8 | Remark 1 |
| UN-II-2A | 64 | | 20.2 | 16.8 | Remark 1 |
| UN-II-2C | 140 | | 21.8 | 16.8 | Remark 1 |
| UN-NII-3 | 165 | | 20.2 | 16.8 | Remark 1 |

Remark 1: See diagrams in separate annex TR17-1-00659T60a-A1

| Set-up no.: | 2 | | | | |
|-------------|--|-------------------|-----------------------|------------------------------|-------------|
| Op. Mode: | 1 (WLAN 5 GHz n Mode B.W. 20 MHz Power Settings: 10) | | | | |
| | Channel No. | Nominal bandwidth | 26 dB Bandwidth [MHz] | 99% Occupied Bandwidth [MHz] | Diagram no. |
| UN-II-1 | 48 | 20 | 20.6 | 18 | Remark 1 |
| UN-II-2A | 64 | | 20.6 | 17.8 | Remark 1 |
| UN-II-2C | 140 | | 25.2 | 18 | Remark 1 |
| UN-NII-3 | 165 | | 20.6 | 17.8 | Remark 1 |

Remark 1: See diagrams in separate annex TR17-1-00659T60a-A1

| Set-up no.: | 2 | | | | |
|-------------|--|-------------------|-----------------------|------------------------------|-------------|
| Op. Mode: | 1 (WLAN 5 GHz ac Mode B.W. 20 MHz Power Settings: 6) | | | | |
| | Channel No. | Nominal bandwidth | 26 dB Bandwidth [MHz] | 99% Occupied Bandwidth [MHz] | Diagram no. |
| UN-II-1 | 48 | 20 | 20.8 | 17.8 | Remark 1 |
| UN-II-2A | 64 | | 20.8 | 17.8 | Remark 1 |
| UN-II-2C | 140 | | 20.8 | 17.8 | Remark 1 |
| UN-NII-3 | 149 | | 20.6 | 17.8 | Remark 1 |

Remark 1: See diagrams in separate annex TR17-1-00659T60a-A1

| | | | | | |
|-------------|---|--|--|--|--|
| Set-up no.: | 2 | | | | |
|-------------|---|--|--|--|--|

| Op. Mode: | 1 (WLAN 5 GHz n Mode B.W. 40 MHz Power Settings: 10) | | | | |
|-----------|--|-------------------|-----------------------|------------------------------|-------------|
| | Channel No. | Nominal bandwidth | 26 dB Bandwidth [MHz] | 99% Occupied Bandwidth [MHz] | Diagram no. |
| UN-II-1 | 48 | 20 | 40.533334 | 32.26667 | Remark 1 |
| UN-II-2A | 62 | | 40.26667 | 32.26667 | Remark 1 |
| UN-II-2C | 102 | | 40.8 | 32.26667 | Remark 1 |
| UN-NII-3 | 159 | | 40.066667 | 32.5333 | Remark 1 |

Remark 1: See diagrams in separate annex TR17-1-00659T60a-A1

| Set-up no.: | 2 | | | | |
|-------------|--|-------------------|-----------------------|------------------------------|-------------|
| Op. Mode: | 1 (WLAN 5 GHz ac Mode B.W. 40 MHz Power Settings: 6) | | | | |
| | Channel No. | Nominal bandwidth | 26 dB Bandwidth [MHz] | 99% Occupied Bandwidth [MHz] | Diagram no. |
| UN-II-1 | 48 | 20 | 41.066667 | 36.26666 | Remark 1 |
| UN-II-2A | 62 | | 40 | 36.26666 | Remark 1 |
| UN-II-2C | 134 | | 40.26667 | 36.26666 | Remark 1 |
| UN-NII-3 | 159 | | 40.26667 | 36.26666 | Remark 1 |

Remark 1: See diagrams in separate annex TR17-1-00659T60a-A1

| Set-up no.: | 2 | | | | |
|-------------|--|-------------------|-----------------------|------------------------------|-------------|
| Op. Mode: | 1 (WLAN 5 GHz ac Mode B.W. 80 MHz Power Settings: 6) | | | | |
| | Channel No. | Nominal bandwidth | 26 dB Bandwidth [MHz] | 99% Occupied Bandwidth [MHz] | Diagram no. |
| UN-II-1 | 42 | 20 | 87.272728 | 76.410256 | Remark 1 |
| UN-II-2A | 58 | | 87.272728 | 76.923076 | Remark 1 |
| UN-II-2C | 122 | | 87.272728 | 76.923076 | Remark 1 |
| UN-NII-3 | 155 | | 86.233767 | 76.410256 | Remark 1 |

Remark 1: See diagrams in separate annex TR17-1-00659T60a-A1

5.3.8. Verdict (assignment): pass

5.4. RF Parameter – Peak Power Spectral Density (PPSD)

5.4.1. Test location and equipment (for reference numbers please see chapter 'List of test equipment')

| | | | |
|---------------|--|--|---|
| test location | <input checked="" type="checkbox"/> CETECOM Essen (Chapter. 2.2.1) | <input type="checkbox"/> Please see Chapter. 2.2.2 | <input type="checkbox"/> Please see Chapter. 2.2.3 |
| test site | <input type="checkbox"/> 441 EMI SAR | <input type="checkbox"/> 487 SAR NSA | <input type="checkbox"/> 337 OATS <input checked="" type="checkbox"/> 347 Radio.lab. <input type="checkbox"/> |

| | | | | | | |
|-----------------|---|---------------------------------------|---|---|--------------------------------------|---|
| receiver | <input type="checkbox"/> 377 ESCS30 | <input type="checkbox"/> 001 ESS | <input checked="" type="checkbox"/> 489 ESU | <input type="checkbox"/> | <input type="checkbox"/> | <input type="checkbox"/> |
| spectr. analys. | <input type="checkbox"/> 215 FSU | <input type="checkbox"/> 120 FSEM | <input type="checkbox"/> 264 FSEK | <input type="checkbox"/> | <input type="checkbox"/> | <input type="checkbox"/> |
| power supply | <input type="checkbox"/> 456 EA 3013A | <input type="checkbox"/> 457 EA 3013A | <input type="checkbox"/> 459 EA 2032-50 | <input type="checkbox"/> 268 EA- 3050 | <input type="checkbox"/> 494 AG6632A | <input checked="" type="checkbox"/> 498 NGPE 40 |
| otherwise | <input checked="" type="checkbox"/> 530 10dB Attenuator | | | <input checked="" type="checkbox"/> cable K15 | | |

5.4.2. References

| | |
|----------------------------|--|
| FCC | <input checked="" type="checkbox"/> Part 15 Subpart C, §15.407(a)(1)(2)(3)(4) |
| ISED | <input checked="" type="checkbox"/> RSS-247, Issue 2: chapter 6.2 and subchapters |
| ANSI | <input checked="" type="checkbox"/> C63.10-2013 |
| KDB Guidances no. | <input checked="" type="checkbox"/> 789033 D02 General UNII test procedures v01r04: Subchapter F <input checked="" type="checkbox"/> 922611 D01 Multiple transmitter output v02r01 |
| Limits [dBm/MHz] | <input checked="" type="checkbox"/> U-NII 1: 5.15-5.25 GHz: FCC Outdoor access point: 17dBm/MHz FCC Indoor Access Point: 17dBm/MHz FCC Mobile & Portable client: 11dBm/MHz |
| | ISED: <input checked="" type="checkbox"/> vehicle equipment by OEM <input checked="" type="checkbox"/> other device: 10 dBm/MHz |
| | <input checked="" type="checkbox"/> U-NII2: 5.25-5.35 GHz: FCC/ ISED: 11dBm |
| | <input checked="" type="checkbox"/> U-NII2+extension: 5.47-5.725 GHz: FCC/ ISED: 11dBm/MHz |
| Limits [dBm/500kHz] | <input checked="" type="checkbox"/> U-NII3: 5.725-5.85 GHz: FCC/ ISED: 30dBm/500kHz |

Remark: --

5.4.3. EUT settings

- different channels have been measured for each transmitting sub-band
- The EUT was instructed to send with maximum power (if adjustable) according applicants instructions
- MIMO applicable measurement techniques (KDB 992611)
- no MIMO applicable

5.4.4. Measurement Method:

SA-1: The procedures were followed for measuring the average power spectrum as described under chapter “maximum conducted output power”: steps (i) to (viii). The measurements have been performed for each output RF-port if applicable. A screenshot and data bins transfer for further calculations were recorded. If the device contains more than one RF-output port, MIMO calculation procedures have been followed according KDB662911, Chapter E.2 a) “Measure and sum spectra across the outputs”. Resulting maximum PSD is reported for the MIMO condition.

The measured value is corrected due to external measuring set-up path losses and the resulting value is compared with the standard requirement. If the limit is E.I.R.P limit the antenna gain is added, eventually the array gain for MIMO systems.

5.4.4.1. Results:

| Set-up no.: | 2 | | | | | |
|-------------|-----------------------------|-------------------|----------------------------------|----------|-----------|-------------|
| Op. Mode: | 1 (20MHz nominal bandwidth) | | | | | |
| Band | Channel No. | Nominal bandwidth | Power spectral density [dBm/MHz] | | | Diagram no. |
| | | | a-Mode | n20-Mode | ac20-Mode | |
| UN-II-1 | 48 | 20 | -5.468 | -5.584 | -9.483 | Remark1 |
| UN-II-2A | 64 | | -3.640 | -4.113 | -7.906 | Remark1 |
| UN-II-2C | 100 | | -- | -- | -6.456 | Remark1 |
| | 140 | | -2.988 | -3.319 | -- | Remark1 |
| UN-NII-3 | 149 | | -- | -- | -10.887 | Remark1 |
| | 165 | | -7.177 | -7.189 | -- | Remark1 |

Remark 1: Only results for worst case modes are displayed, for additional information please refer to diagrams in separate annex TR17-1-00659T60a-A1

| Set-up no.: | 2 | | | | |
|-------------|-----------------------------|-------------------|----------------------------------|-----------|-------------|
| Op. Mode: | 1 (40MHz nominal bandwidth) | | | | |
| Band | Channel No. | Nominal bandwidth | Power spectral density [dBm/MHz] | | Diagram no. |
| | | | n40-Mode | AC40-Mode | |
| UN-II-1 | 46 | 40 | -8.194 | -11.856 | Remark 1 |
| UN-II-2A | 62 | | -7.044 | -11.181 | Remark 1 |
| UN-II-2C | 102 | | -5.349 | -- | Remark 1 |
| | 134 | | -- | -10.824 | Remark 1 |
| UN-NII-3 | 159 | | -9.567 | -14.403 | Remark 1 |

Remark 1: Only results for worst case modes are displayed, for additional information please refer to diagrams in separate annex TR17-1-00659T60a-A1

| Set-up no.: | 2 | | | |
|-------------|-----------------------------|-------------------|----------------------------------|-------------|
| Op. Mode: | 1 (80MHz nominal bandwidth) | | | |
| Band | Channel No. | Nominal bandwidth | Power spectral density [dBm/MHz] | Diagram no. |
| | | | AC80-Mode | |
| UN-II-1 | 42 | 80 | -15.769 | Remark 1 |
| UN-II-2A | 58 | | -10.970 | Remark 1 |
| UN-II-2C | 122 | | -13.333 | Remark 1 |
| UN-II-3 | 155 | | -17.906 | Remark 1 |

Remark 1: Only results for worst case modes are displayed, for additional information please refer to diagrams in separate annex TR17-1-00659T60a-A1

5.4.5. Verdict: Passed

5.5. General Limit - Radiated field strength emissions below 30 MHz

5.5.1. Test location and equipment

| | | | |
|-----------------|--|--|--|
| test location | <input checked="" type="checkbox"/> CETECOM Essen (Chapter. 2.2.1) | <input type="checkbox"/> Please see Chapter. 2.2.2 | <input type="checkbox"/> Please see Chapter. 2.2.3 |
| test site | <input checked="" type="checkbox"/> 441 EMI SAR | <input type="checkbox"/> 487 SAR NSA | <input type="checkbox"/> 347 Radio.lab. |
| receiver | <input type="checkbox"/> 377 ESCS30 | <input checked="" type="checkbox"/> 001 ESS | <input type="checkbox"/> |
| spectr. analys. | <input type="checkbox"/> 584 FSU | <input type="checkbox"/> 120 FSEM | <input type="checkbox"/> 264 FSEK |
| antenna | <input type="checkbox"/> 574 BTA-L | <input type="checkbox"/> 133 EMCO3115 | <input type="checkbox"/> 302 BBHA9170 |
| signaling | <input type="checkbox"/> 392 MT8820A | <input type="checkbox"/> 371 CBT32 | <input type="checkbox"/> 547 CMU |
| otherwise | <input type="checkbox"/> 400 FTC40x15E | <input type="checkbox"/> 401 FTC40x15E | <input type="checkbox"/> 110 USB LWL |
| DC power | <input type="checkbox"/> 671 EA-3013S | <input checked="" type="checkbox"/> 457 EA 3013A | <input type="checkbox"/> 459 EA 2032-50 |
| Supply voltage | <input type="checkbox"/> 230 V 50 Hz via public mains | <input checked="" type="checkbox"/> 15 V DC | |

5.5.2. Requirements

| FCC | Part 15, Subpart C, §15.205 & §15.209 | | | |
|-----------------|---------------------------------------|-----------------------|--------------|---|
| ANSI | C63.10-2013 | | | |
| Frequency [MHz] | Field strength limit | | Distance [m] | Remarks |
| | [µV/m] | [dBµV/m] | | |
| 0.009 – 0.490 | 2400/f (kHz) | 67.6 – 20Log(f) (kHz) | 300 | Correction factor used due to measurement distance of 3 m |
| 0.490 – 1.705 | 24000/f (kHz) | 87.6 – 20Log(f) (kHz) | 30 | Correction factor used due to measurement distance of 3 m |
| 1.705 – 30 | 30 | 29.5 | 30 | Correction factor used due to measurement distance of 3 m |

5.5.3. Test condition and test set-up

| | | | |
|---------------------------------------|---|---|--|
| Signal link to test system (if used): | <input type="checkbox"/> air link | <input type="checkbox"/> cable connection | <input checked="" type="checkbox"/> none |
| EUT-grounding | <input checked="" type="checkbox"/> none | <input type="checkbox"/> with power supply | <input type="checkbox"/> additional connection |
| Equipment set up | <input checked="" type="checkbox"/> table top | | <input type="checkbox"/> floor standing |
| Climatic conditions | Temperature: (22±3°C) | | Rel. humidity: (40±20)% |
| EMI-Receiver or Analyzer Settings | Scan data | <input checked="" type="checkbox"/> 9 – 150 kHz RBW/VBW = 200 Hz Scan step = 80 Hz <input checked="" type="checkbox"/> 150 kHz – 30 MHz RBW/VBW = 9 kHz Scan step = 4 kHz <input type="checkbox"/> other: | |
| | Scan-Mode Detector Mode: Sweep-Time | <input checked="" type="checkbox"/> 6 dB EMI-Receiver Mode <input type="checkbox"/> 3dB Spectrum analyser Mode Peak (pre-measurement) and Quasi-PK/Average (final if applicable) Repetitive-Scan, max-hold Coupled – calibrated display if continuous signal otherwise adapted to EUT's individual transmission duty-cycle | |
| General measurement procedures | Please see chapter "Test system set-up radiated magnetic field measurements below 30 MHz" | | |

5.5.4. Radiated Field Strength Emissions – 9 kHz to 30 MHz Results

| Radiated Field Strength Emissions – 9 kHz to 30 MHz | | | | | | | | | | |
|---|--|-------------------------------------|----|-------------------------------------|------------------------------|--------------------------|---------------|--|--|---------|
| Temperature :+21 °C | | Technology: WLAN 5 GHz 802.11a/n/ac | | | TX-Fixed Channel (Modulated) | | | | | |
| Diagram No. (Remark 1) | Test Settings | | | | Set-up no. | OP-mode no. | Used detector | | | Verdict |
| | Mode B.W. Data Rate Frequency Band - Channel (Frequency) | PK | AV | QP | | | | | | |
| 2.10a/ 2.10b | a Mode 20 MHz 6 Mbit U-NII-1-Ch 48 (5240 MHz) | 1 | 1 | <input checked="" type="checkbox"/> | <input type="checkbox"/> | <input type="checkbox"/> | Pass | | | |
| 2.11a/ 2.11b | a Mode 20 MHz 6 Mbit U-NII-2A-Ch 64 (5320 MHz) | 1 | 1 | <input checked="" type="checkbox"/> | <input type="checkbox"/> | <input type="checkbox"/> | Pass | | | |
| 2.12a/ 2.12b | a Mode 20 MHz 6 Mbit U-NII-2C-Ch 140(5700 MHz) | 1 | 1 | <input checked="" type="checkbox"/> | <input type="checkbox"/> | <input type="checkbox"/> | Pass | | | |
| 2.13a/ 2.13b | a Mode 20 MHz 6 Mbit U-NII-3-Ch 165 (5825 MHz) | 1 | 1 | <input checked="" type="checkbox"/> | <input type="checkbox"/> | <input type="checkbox"/> | Pass | | | |
| 2.14a/ 2.14b | n Mode 20 MHz MCS0 U-NII-1-Ch 48 (5240 MHz) | 1 | 1 | <input checked="" type="checkbox"/> | <input type="checkbox"/> | <input type="checkbox"/> | Pass | | | |
| 2.15a/ 2.15b | n Mode 20 MHz MCS0 U-NII-2A-Ch 64 (5320 MHz) | 1 | 1 | <input checked="" type="checkbox"/> | <input type="checkbox"/> | <input type="checkbox"/> | Pass | | | |
| 2.16a/ 2.16b | n Mode 20 MHz MCS0 U-NII-2C-Ch 140(5700 MHz) | 1 | 1 | <input checked="" type="checkbox"/> | <input type="checkbox"/> | <input type="checkbox"/> | Pass | | | |
| 2.17a/ 2.17b | n Mode 20 MHz MCS0 U-NII-3-Ch 165 (5825 MHz) | 1 | 1 | <input checked="" type="checkbox"/> | <input type="checkbox"/> | <input type="checkbox"/> | Pass | | | |
| 2.23a/ 2.23b | ac Mode 20 MHz MCS0 U-NII-1-Ch 48 (5240 MHz) | 1 | 1 | <input checked="" type="checkbox"/> | <input type="checkbox"/> | <input type="checkbox"/> | Pass | | | |
| 2.24a/ 2.24b | ac Mode 20 MHz MCS0 U-NII-2A-Ch 64 (5320 MHz) | 1 | 1 | <input checked="" type="checkbox"/> | <input type="checkbox"/> | <input type="checkbox"/> | Pass | | | |
| 2.25a/ 2.25b | ac Mode 20 MHz MCS0 U-NII-2C-Ch 100(5500 MHz) | 1 | 1 | <input checked="" type="checkbox"/> | <input type="checkbox"/> | <input type="checkbox"/> | Pass | | | |
| 2.26a/ 2.26b | ac Mode 20 MHz MCS0 U-NII-3-Ch 149 (5745 MHz) | 1 | 1 | <input checked="" type="checkbox"/> | <input type="checkbox"/> | <input type="checkbox"/> | Pass | | | |
| 2.06a/ 2.06b | n Mode 40 MHz MCS1 U-NII-2C-Ch 46 (5230 MHz) | 1 | 1 | <input checked="" type="checkbox"/> | <input type="checkbox"/> | <input type="checkbox"/> | Pass | | | |
| 2.07a/ 2.07b | n Mode 40 MHz MCS3 U-NII-3-Ch 62 (5310 MHz) | 1 | 1 | <input checked="" type="checkbox"/> | <input type="checkbox"/> | <input type="checkbox"/> | Pass | | | |
| 2.08a/ 2.08b | n Mode 40 MHz MCS1 U-NII-1-Ch 102 (5510MHz) | 1 | 1 | <input checked="" type="checkbox"/> | <input type="checkbox"/> | <input type="checkbox"/> | Pass | | | |
| 2.09a/ 2.09b | n Mode 40 MHz MCS5 U-NII-2A-Ch 151 (5755 MHz) | 1 | 1 | <input checked="" type="checkbox"/> | <input type="checkbox"/> | <input type="checkbox"/> | Pass | | | |
| 2.18a/ 2.18b | ac Mode 40 MHz MCS6 U-NII-2C-Ch 46 (5230 MHz) | 1 | 1 | <input checked="" type="checkbox"/> | <input type="checkbox"/> | <input type="checkbox"/> | Pass | | | |
| 2.19a/ 2.19b | ac Mode 40 MHz MCS6 U-NII-3-Ch 62 (5310 MHz) | 1 | 1 | <input checked="" type="checkbox"/> | <input type="checkbox"/> | <input type="checkbox"/> | Pass | | | |
| 2.20a/ 2.20b | ac Mode 40 MHz MCS6 U-NII-1-Ch 134 (5670MHz) | 1 | 1 | <input checked="" type="checkbox"/> | <input type="checkbox"/> | <input type="checkbox"/> | Pass | | | |
| 2.22a/ 2.22b | ac Mode 40 MHz MCS6 U-NII-2A-Ch 159 (5795 MHz) | 1 | 1 | <input checked="" type="checkbox"/> | <input type="checkbox"/> | <input type="checkbox"/> | Pass | | | |
| 2.01a/ 2.01b | ac Mode 80 MHz MCS0 U-NII-2C-Ch 42(5210 MHz) | 1 | 1 | <input checked="" type="checkbox"/> | <input type="checkbox"/> | <input type="checkbox"/> | Pass | | | |
| 2.02a/ 2.02b | ac Mode 80 MHz MCS0 U-NII-3-Ch 58 (5290 MHz) | 1 | 1 | <input checked="" type="checkbox"/> | <input type="checkbox"/> | <input type="checkbox"/> | Pass | | | |
| 2.03a/ 2.03b | ac Mode 80 MHz MCS0 U-NII-2C-Ch 106(5530 MHz) | 1 | 1 | <input checked="" type="checkbox"/> | <input type="checkbox"/> | <input type="checkbox"/> | Pass | | | |
| 2.04a/ 2.04b | ac Mode 80 MHz MCS0 U-NII-3-Ch 122 (5610 MHz) | 1 | 1 | <input checked="" type="checkbox"/> | <input type="checkbox"/> | <input type="checkbox"/> | Pass | | | |
| 2.05a/ 2.05b | ac Mode 80 MHz MCS0 U-NII-3-Ch 155 (5775 MHz) | 1 | 1 | <input checked="" type="checkbox"/> | <input type="checkbox"/> | <input type="checkbox"/> | Pass | | | |

Remark 1: See diagrams in separate annex TR17-1-00659T60a-A1

5.5.5. Correction factors due to reduced meas. distance (f < 30 MHz)

The used correction factors when the measurement distance is reduced compared to regulatory measurement distance, are calculated according to Extrapolation formulas valid for EUT's with maximum dimension of 0.625xLambda. Formula 2+3+4 as presented in ANSI C63.10, Chapter 6.4.4 are used for the calculations of proper extrapolation factors.

| Frequency Range | f [kHz/MHz] | Lambda [m] | Far-Field Point [m] | Distance Limit accord. 15.209 [m] | 1st Condition (dmeas < D _{near-field}) | 2'te Condition (Limit distance bigger d _{near-field}) | Distance Correction accord. Formula |
|-----------------|-------------|------------|---------------------|-----------------------------------|--|---|-------------------------------------|
| kHz | 9,00E+03 | 33333,33 | 5305,17 | 300 | fulfilled | not fulfilled | -80,00 |
| | 1,00E+04 | 30000,00 | 4774,65 | | fulfilled | not fulfilled | -80,00 |
| | 2,00E+04 | 15000,00 | 2387,33 | | fulfilled | not fulfilled | -80,00 |
| | 3,00E+04 | 10000,00 | 1591,55 | | fulfilled | not fulfilled | -80,00 |
| | 4,00E+04 | 7500,00 | 1193,66 | | fulfilled | not fulfilled | -80,00 |
| | 5,00E+04 | 6000,00 | 954,93 | | fulfilled | not fulfilled | -80,00 |
| | 6,00E+04 | 5000,00 | 795,78 | | fulfilled | not fulfilled | -80,00 |
| | 7,00E+04 | 4285,71 | 682,09 | | fulfilled | not fulfilled | -80,00 |
| | 8,00E+04 | 3750,00 | 596,83 | | fulfilled | not fulfilled | -80,00 |
| | 9,00E+04 | 3333,33 | 530,52 | | fulfilled | not fulfilled | -80,00 |
| | 1,00E+05 | 3000,00 | 477,47 | | fulfilled | not fulfilled | -80,00 |
| | 1,25E+05 | 2400,00 | 381,97 | | fulfilled | not fulfilled | -80,00 |
| | 2,00E+05 | 1500,00 | 238,73 | | fulfilled | fulfilled | -78,02 |
| | 3,00E+05 | 1000,00 | 159,16 | | fulfilled | fulfilled | -74,49 |
| | 4,00E+05 | 750,00 | 119,37 | | fulfilled | fulfilled | -72,00 |
| | 4,90E+05 | 612,24 | 97,44 | | fulfilled | fulfilled | -70,23 |
| | 5,00E+05 | 600,00 | 95,49 | | fulfilled | not fulfilled | -40,00 |
| | 6,00E+05 | 500,00 | 79,58 | | fulfilled | not fulfilled | -40,00 |
| 7,00E+05 | 428,57 | 68,21 | fulfilled | not fulfilled | -40,00 | | |
| 8,00E+05 | 375,00 | 59,68 | fulfilled | not fulfilled | -40,00 | | |
| 9,00E+05 | 333,33 | 53,05 | fulfilled | not fulfilled | -40,00 | | |
| MHz | 1,00 | 300,00 | 47,75 | 30 | fulfilled | not fulfilled | -40,00 |
| | 1,59 | 188,50 | 30,00 | | fulfilled | not fulfilled | -40,00 |
| | 2,00 | 150,00 | 23,87 | | fulfilled | fulfilled | -38,02 |
| | 3,00 | 100,00 | 15,92 | | fulfilled | fulfilled | -34,49 |
| | 4,00 | 75,00 | 11,94 | | fulfilled | fulfilled | -32,00 |
| | 5,00 | 60,00 | 9,55 | | fulfilled | fulfilled | -30,06 |
| | 6,00 | 50,00 | 7,96 | | fulfilled | fulfilled | -28,47 |
| | 7,00 | 42,86 | 6,82 | | fulfilled | fulfilled | -27,13 |
| | 8,00 | 37,50 | 5,97 | | fulfilled | fulfilled | -25,97 |
| | 9,00 | 33,33 | 5,31 | | fulfilled | fulfilled | -24,95 |
| | 10,00 | 30,00 | 4,77 | | fulfilled | fulfilled | -24,04 |
| | 10,60 | 28,30 | 4,50 | | fulfilled | fulfilled | -23,53 |
| | 11,00 | 27,27 | 4,34 | | fulfilled | fulfilled | -23,21 |
| | 12,00 | 25,00 | 3,98 | | fulfilled | fulfilled | -22,45 |
| | 13,56 | 22,12 | 3,52 | | fulfilled | fulfilled | -21,39 |
| | 15,00 | 20,00 | 3,18 | | fulfilled | fulfilled | -20,51 |
| | 15,92 | 18,85 | 3,00 | | fulfilled | fulfilled | -20,00 |
| | 17,00 | 17,65 | 2,81 | | not fulfilled | fulfilled | -20,00 |
| | 18,00 | 16,67 | 2,65 | | not fulfilled | fulfilled | -20,00 |
| | 20,00 | 15,00 | 2,39 | | not fulfilled | fulfilled | -20,00 |
| | 21,00 | 14,29 | 2,27 | | not fulfilled | fulfilled | -20,00 |
| 23,00 | 13,04 | 2,08 | not fulfilled | fulfilled | -20,00 | | |
| 25,00 | 12,00 | 1,91 | not fulfilled | fulfilled | -20,00 | | |
| 27,00 | 11,11 | 1,77 | not fulfilled | fulfilled | -20,00 | | |
| 29,00 | 10,34 | 1,65 | not fulfilled | fulfilled | -20,00 | | |
| 30,00 | 10,00 | 1,59 | not fulfilled | fulfilled | -20,00 | | |

5.6. General Limit - Radiated field strength emissions, 30 MHz - 1 GHz

5.6.1. Test location and equipment

| | | | |
|-----------------|--|--|--|
| test location | <input checked="" type="checkbox"/> CETECOM Essen (Chapter. 2.2.1) | <input type="checkbox"/> Please see Chapter. 2.2.2 | <input type="checkbox"/> Please see Chapter. 2.2.3 |
| test site | <input checked="" type="checkbox"/> 441 EMI SAR | <input checked="" type="checkbox"/> 487 SAR NSA | |
| receiver | <input type="checkbox"/> 377 ESCS30 | <input checked="" type="checkbox"/> 001 ESS | <input type="checkbox"/> 489 ESU 40 <input type="checkbox"/> 620 ESU 26 |
| spectr. analys. | <input type="checkbox"/> 584 FSU | <input type="checkbox"/> 120 FSEM | <input type="checkbox"/> 264 FSEK |
| antenna | <input checked="" type="checkbox"/> 574 BTA-L | <input type="checkbox"/> 133 EMCO3115 | <input type="checkbox"/> 302 BBHA9170 <input type="checkbox"/> 289 CBL 6141 <input type="checkbox"/> 030 HFH-Z2 <input type="checkbox"/> 477 GPS |
| signaling | <input type="checkbox"/> 392 MT8820A | <input type="checkbox"/> 371 CBT32 | <input type="checkbox"/> 547 CMU <input type="checkbox"/> 594 CMW |
| otherwise | <input type="checkbox"/> 400 FTC40x15E | <input type="checkbox"/> 401 FTC40x15E | <input type="checkbox"/> 110 USB LWL <input checked="" type="checkbox"/> 482 Filter Matrix |
| DC power | <input type="checkbox"/> 671 EA-3013S | <input checked="" type="checkbox"/> 457 EA 3013A | <input type="checkbox"/> 459 EA 2032-50 <input type="checkbox"/> 268 EA- 3050 <input type="checkbox"/> 494 AG6632A <input type="checkbox"/> 498 NGPE |
| Supply voltage | <input type="checkbox"/> 230 V 50 Hz via public mains | <input checked="" type="checkbox"/> 15V DC | |

5.6.2. Requirements/Limits

| | | | |
|--------------|-----------------|---|---------------------------|
| FCC | | <input type="checkbox"/> Part 15 Subpart B, §15.109, class B <input checked="" type="checkbox"/> Part 15 Subpart C, §15.209 @ frequencies defined in §15.205 | |
| ANSI | | <input type="checkbox"/> C63.4-2014 <input checked="" type="checkbox"/> C63.10-2013 | |
| Limit | Frequency [MHz] | Radiated emissions limits, 3 meters | |
| | | QUASI Peak [μ V/m] | QUASI-Peak [dB μ V/m] |
| | 30 - 88 | 100 | 40.0 |
| | 88 - 216 | 150 | 43.5 |
| | 216 - 960 | 200 | 46.0 |
| | above 960 | 500 | 54.0 |

5.6.3. Restricted bands of operation (FCC §15.205)

| MHz | MHz | MHz | GHz |
|-------------------|---------------------|---------------|-------------|
| 0.090-0.110 | 16.42-16.423 | 399.9-410 | 4.5-5.15 |
| 0.495-0.505 | 16.69475-16.69525 | 608-614 | 5.35-5.46 |
| 2.1735-2.1905 | 16.80425-16.80475 | 960-1240 | 7.25-7.75 |
| 4.125-4.128 | 25.5-25.67 | 1300-1427 | 8.025-8.5 |
| 4.20725-4.20775 | 37.5-38.25 | 1645.5-1646.5 | 9.3-9.5 |
| 6.215-6.218 | 73-74.6 | 1660-1710 | 10.6-12.7 |
| 6.26775-6.26825 | 74.8-75.2 | 1718.8-1722.2 | 13.25-13.4 |
| 6.31175-6.31225 | 108-121.94 | 2200-2300 | 14.47-14.5 |
| 8.291-8.294 | 123-138 | 2310-2390 | 15.35-16.2 |
| 8.362-8.366 | 149.9-150.05 | 2483.5-2500 | 17.7-21.4 |
| 8.37625-8.38675 | 156.52475-156.52525 | 2690-2900 | 22.01-23.12 |
| 8.41425-8.41475 | 156.7-156.9 | 3260-3267 | 23.6-24.0 |
| 12.29-12.293 | 162.0125-167.17 | 3332-3339 | 31.2-31.8 |
| 12.51975-12.52025 | 167.72-173.2 | 3345.8-3358 | 36.43-36.5 |
| 12.57675-12.57725 | 240-285 | 3600-4400 | -- |
| 13.36-13.41 | 322-335.4 | -- | -- |

Remark: only spurious emissions are allowed within these frequency bands not exceeding the limits per §15.209

5.6.4. Test condition and measurement test set-up

| | | | | |
|---------------------------------------|---|---|--|--|
| Signal link to test system (if used): | | <input type="checkbox"/> air link | <input type="checkbox"/> cable connection | <input checked="" type="checkbox"/> none |
| EUT-grounding | | <input checked="" type="checkbox"/> none | <input type="checkbox"/> with power supply | <input type="checkbox"/> additional connection |
| Equipment set up | | <input checked="" type="checkbox"/> table top 0.8m height <input type="checkbox"/> floor standing | | |
| Climatic conditions | | Temperature: (22±3°C) | | Rel. humidity: (40±20)% |
| EMI-Receiver (Analyzer) Settings | Scan frequency range: | <input checked="" type="checkbox"/> 30 – 1000 MHz <input type="checkbox"/> other: | | |
| | Scan-Mode | <input checked="" type="checkbox"/> 6 dB EMI-Receiver Mode <input type="checkbox"/> 3 dB spectrum analyser mode | | |
| | Detector | Peak / Quasi-peak | | |
| | RBW/VBW | 100 kHz/300 kHz | | |
| | Mode: | Repetitive-Scan, max-hold | | |
| Scan step | 80 kHz | | | |
| Sweep-Time | Coupled – calibrated display if continuous tx-signal otherwise adapted to EUT’s individual duty-cycle | | | |
| General measurement procedures | | Please see chapter “Test system set-up for electric field measurement in the range 30 MHz to 1 GHz” | | |

5.6.5. Radiated Field Strength Emissions – 30 MHz to 1 GHz Results

| Radiated Field Strength Emissions – 30 MHz to 1 GHz | | | | | | | | | | |
|---|--|----------------------------------|----|-------------------------------------|------------------------------|--------------------------|---------------|--|--|---------|
| Temperature :+21 °C | | Technology: WLAN 5 GHz 802.11a/n | | | TX-Fixed Channel (Modulated) | | | | | |
| Diagram No. (Remark 1) | Test Settings | | | | Set-up no. | OP-mode no. | Used detector | | | Verdict |
| | Mode B.W. Data Rate Frequency Band - Channel (Frequency) | PK | AV | QP | | | | | | |
| 3.10a/ 3.10b | a Mode 20 MHz 6 Mbit U-NII-1-Ch 48 (5240 MHz) | 1 | 1 | <input checked="" type="checkbox"/> | <input type="checkbox"/> | <input type="checkbox"/> | Pass | | | |
| 3.11a/ 3.11b | a Mode 20 MHz 6 Mbit U-NII-2A-Ch 64 (5320 MHz) | 1 | 1 | <input checked="" type="checkbox"/> | <input type="checkbox"/> | <input type="checkbox"/> | Pass | | | |
| 3.12a/ 3.12b | a Mode 20 MHz 6 Mbit U-NII-2C-Ch 140(5700 MHz) | 1 | 1 | <input checked="" type="checkbox"/> | <input type="checkbox"/> | <input type="checkbox"/> | Pass | | | |
| 3.13a/ 3.13b | a Mode 20 MHz 6 Mbit U-NII-3-Ch 165 (5825 MHz) | 1 | 1 | <input checked="" type="checkbox"/> | <input type="checkbox"/> | <input type="checkbox"/> | Pass | | | |
| 3.14a/ 3.14b | n Mode 20 MHz MCS0 U-NII-1-Ch 48 (5240 MHz) | 1 | 1 | <input checked="" type="checkbox"/> | <input type="checkbox"/> | <input type="checkbox"/> | Pass | | | |
| 3.15a/ 3.15b | n Mode 20 MHz MCS0 U-NII-2A-Ch 64 (5320 MHz) | 1 | 1 | <input checked="" type="checkbox"/> | <input type="checkbox"/> | <input type="checkbox"/> | Pass | | | |
| 3.16a/ 3.16b | n Mode 20 MHz MCS0 U-NII-2C-Ch 140(5700 MHz) | 1 | 1 | <input checked="" type="checkbox"/> | <input type="checkbox"/> | <input type="checkbox"/> | Pass | | | |
| 3.17a/ 3.17b | n Mode 20 MHz MCS0 U-NII-3-Ch 165 (5825 MHz) | 1 | 1 | <input checked="" type="checkbox"/> | <input type="checkbox"/> | <input type="checkbox"/> | Pass | | | |
| 3.23a/ 3.23b | ac Mode 20 MHz MCS0 U-NII-1-Ch 48 (5240 MHz) | 1 | 1 | <input checked="" type="checkbox"/> | <input type="checkbox"/> | <input type="checkbox"/> | Pass | | | |
| 3.24a/ 3.24b | ac Mode 20 MHz MCS0 U-NII-2A-Ch 64 (5320 MHz) | 1 | 1 | <input checked="" type="checkbox"/> | <input type="checkbox"/> | <input type="checkbox"/> | Pass | | | |
| 3.25a/ 3.25b | ac Mode 20 MHz MCS0 U-NII-2C-Ch 100(5500 MHz) | 1 | 1 | <input checked="" type="checkbox"/> | <input type="checkbox"/> | <input type="checkbox"/> | Pass | | | |
| 3.26a/ 3.26b | ac Mode 20 MHz MCS0 U-NII-3-Ch 149 (5745 MHz) | 1 | 1 | <input checked="" type="checkbox"/> | <input type="checkbox"/> | <input type="checkbox"/> | Pass | | | |

| Radiated Field Strength Emissions – 30 MHz to 1 GHz | | | | | | | |
|--|--|---|---|-------------------------------------|-------------------------------------|--------------------------|-------------|
| Temperature :+21 °C | | Technology: WLAN 5 GHz 802.11a/n | | | TX-Fixed Channel (Modulated) | | |
| 3.06a/ 3.06b | n Mode 40 MHz MCS1 U-NII-2C-Ch 46 (5230 MHz) | 1 | 1 | <input checked="" type="checkbox"/> | <input type="checkbox"/> | <input type="checkbox"/> | Pass |
| 3.07a/ 3.07b | n Mode 40 MHz MCS3 U-NII-3-Ch 62 (5310 MHz) | 1 | 1 | <input checked="" type="checkbox"/> | <input type="checkbox"/> | <input type="checkbox"/> | Pass |
| 3.08a/ 3.08b | n Mode 40 MHz MCS1 U-NII-1-Ch 102 (5510MHz) | 1 | 1 | <input checked="" type="checkbox"/> | <input type="checkbox"/> | <input type="checkbox"/> | Pass |
| 3.09a/ 3.09b | n Mode 40 MHz MCS5 U-NII-2A-Ch 151 (5755 MHz) | 1 | 1 | <input checked="" type="checkbox"/> | <input type="checkbox"/> | <input type="checkbox"/> | Pass |
| 3.18a/ 3.18b | ac Mode 40 MHz MCS6 U-NII-2C-Ch 46 (5230 MHz) | 1 | 1 | <input checked="" type="checkbox"/> | <input type="checkbox"/> | <input type="checkbox"/> | Pass |
| 3.19a/ 3.19b | ac Mode 40 MHz MCS6 U-NII-3-Ch 62 (5310 MHz) | 1 | 1 | <input checked="" type="checkbox"/> | <input type="checkbox"/> | <input type="checkbox"/> | Pass |
| 3.20a/ 3.20b | ac Mode 40 MHz MCS6 U-NII-1-Ch 134 (5670MHz) | 1 | 1 | <input checked="" type="checkbox"/> | <input type="checkbox"/> | <input type="checkbox"/> | Pass |
| 3.22a/ 3.22b | ac Mode 40 MHz MCS6 U-NII-2A-Ch 159 (5795 MHz) | 1 | 1 | <input checked="" type="checkbox"/> | <input type="checkbox"/> | <input type="checkbox"/> | Pass |
| 3.01a/ 3.01b | ac Mode 80 MHz MCS0 U-NII-2C-Ch 42(5210 MHz) | 1 | 1 | <input checked="" type="checkbox"/> | <input type="checkbox"/> | <input type="checkbox"/> | Pass |
| 3.02a/ 3.02b | ac Mode 80 MHz MCS0 U-NII-3-Ch 58 (5290 MHz) | 1 | 1 | <input checked="" type="checkbox"/> | <input type="checkbox"/> | <input type="checkbox"/> | Pass |
| 3.03a/ 3.03b | ac Mode 80 MHz MCS0 U-NII-2C-Ch 106(5530 MHz) | 1 | 1 | <input checked="" type="checkbox"/> | <input type="checkbox"/> | <input type="checkbox"/> | Pass |
| 3.04a/ 3.04b | ac Mode 80 MHz MCS0 U-NII-3-Ch 122 (5610 MHz) | 1 | 1 | <input checked="" type="checkbox"/> | <input type="checkbox"/> | <input type="checkbox"/> | Pass |
| 3.05a/ 3.05b | ac Mode 80 MHz MCS0 U-NII-3-Ch 155 (5775 MHz) | 1 | 1 | <input checked="" type="checkbox"/> | <input type="checkbox"/> | <input type="checkbox"/> | Pass |
| Remark 1: See diagrams in separate annex TR17-1-00659T60a-A1 | | | | | | | |

5.7. General Limit - Radiated emissions, above 1 GHz

5.7.1. Test location and equipment FAR

| | | | | | | |
|-----------------|---|--|---|--|--|----------------------------------|
| test site | <input type="checkbox"/> 441 EMI SAR | <input type="checkbox"/> 348 EMI cond. | <input checked="" type="checkbox"/> 443 EMI FAR | <input type="checkbox"/> 347 Radio.lab. | <input type="checkbox"/> 337 OATS | <input type="checkbox"/> |
| spectr. analys. | <input type="checkbox"/> 584 FSU | <input type="checkbox"/> 120 FSEM | <input type="checkbox"/> 264 FSEK | <input checked="" type="checkbox"/> 489 ESU 40 | <input type="checkbox"/> | <input type="checkbox"/> |
| antenna meas | <input type="checkbox"/> 574 BTA-L | <input type="checkbox"/> 289 CBL 6141 | <input type="checkbox"/> 608 HL 562 | <input checked="" type="checkbox"/> 549 HL025 | <input checked="" type="checkbox"/> 302 BBHA9170 | <input type="checkbox"/> 477 GPS |
| antenna meas | <input type="checkbox"/> 123 HUF-Z2 | <input type="checkbox"/> 132 HUF-Z3 | <input type="checkbox"/> 030 HFH-Z2 | <input type="checkbox"/> 376 BBHA9120E | | |
| antenna subst | <input type="checkbox"/> 071 HUF-Z2 | <input type="checkbox"/> 020 EMCO3115 | <input type="checkbox"/> 063 LP 3146 | <input type="checkbox"/> 303 BBHA9170 | <input type="checkbox"/> | <input type="checkbox"/> |
| multimeter | <input type="checkbox"/> 341 Fluke 112 | <input type="checkbox"/> | <input type="checkbox"/> | <input type="checkbox"/> | <input type="checkbox"/> | <input type="checkbox"/> |
| signaling | <input type="checkbox"/> 392 MT8820A | <input type="checkbox"/> 371 CBT32 | <input type="checkbox"/> 547 CMU | <input type="checkbox"/> 594 CMW | | |
| DCpower | <input type="checkbox"/> 611 E3632A | <input checked="" type="checkbox"/> 087 EA3013 | <input type="checkbox"/> 354 NGPE 40 | <input type="checkbox"/> 349 car battery | <input type="checkbox"/> 350 Car battery | <input type="checkbox"/> |
| Supply voltage | <input type="checkbox"/> 230 V 50 Hz via public mains | | <input checked="" type="checkbox"/> 15V DC | | | |

5.7.2. Requirements/Limits

| | | | | |
|---|---|----------------|----------------|---|
| FCC | <input type="checkbox"/> Part 15 Subpart B, §15.109 class B <input checked="" type="checkbox"/> Part 15 Subpart C, §15.209 for frequencies defined in §15.205 <input checked="" type="checkbox"/> Part 15 Subpart C, §15.407(b)(1)(2)(3)(4)(5)(6)(7)(8) | | | |
| ANSI | <input type="checkbox"/> C63.4-2014 <input checked="" type="checkbox"/> C63.10-2013 | | | |
| Frequency [MHz] | Limits | | | |
| | AV [µV/m] | AV [dBµV/m] | Peak [µV/m] | Peak [dBµV/m] or [dBm/MHz] |
| above 1 GHz for frequencies as defined in §15.205 | 500 | 54.0 | 5000 | 74.0 dBµV/m |
| §15.407(b)(1)(2)(3)(4) | -- | -- | -- | (b)(1): 5.15-5.25GHz: -27dBm eirp (b)(2): 5.25-5.35GHz: -27dBm eirp (b)(3): 5.47-5.725 GHz: -27dBm eirp (b)(4): 5.725-5.85GHz: Spectrum mask |

5.7.3. Test condition and measurement test set-up

| | | | |
|---------------------------------------|--|--|--|
| Signal link to test system (if used): | <input type="checkbox"/> air link | <input type="checkbox"/> cable connection | <input checked="" type="checkbox"/> none |
| EUT-grounding | <input checked="" type="checkbox"/> none | <input type="checkbox"/> with power supply | <input type="checkbox"/> additional connection |
| Equipment set up | <input checked="" type="checkbox"/> table top 1.5m height | | <input type="checkbox"/> floor standing |
| Climatic conditions | Temperature: (22±3°C) | | Rel. humidity: (40±20)% |
| Spectrum-Analyzer settings | Scan frequency range: <input checked="" type="checkbox"/> 1 – 18 GHz <input type="checkbox"/> 18 – 25 GHz <input checked="" type="checkbox"/> 18 – 40 GHz <input type="checkbox"/> other: <input checked="" type="checkbox"/> 6 dB EMI-Receiver Mode <input type="checkbox"/> 3 dB Spectrum analyser Mode Peak and Average 1 MHz / 3 MHz Mode: Repetitive-Scan, max-hold Scan step: 400 kHz Sweep-Time: Coupled – calibrated display if CW signal otherwise adapted to EUT’s individual duty-cycle | | |
| General measurement procedures | Please see chapter “Test system set-up for radiated electric field measurements above 1 GHz” | | |

5.7.4. Radiated Field Strength Emissions – 1 GHz to 7 GHz Results

| Radiated Field Strength Emissions – 1 GHz to 7 GHz | | | | | | | |
|--|--|----------------------------------|-------------|-------------------------------------|-------------------------------------|--------------------------|---------|
| Temperature :+21 °C | | Technology: WLAN 5 GHz 802.11a/n | | TX-Fixed Channel (Modulated) | | | |
| Diagram No. (Remark 1) | Test Settings Mode B.W. Data Rate Channel | Set-up no. | OP-mode no. | Used detector | | | Verdict |
| | | | | PK | AV | QP | |
| 4.51 | 11ac 80MHz VHT_SS1MCS0 42 | 1 | 1 | <input checked="" type="checkbox"/> | <input checked="" type="checkbox"/> | <input type="checkbox"/> | Pass |
| 4.52 | 11ac 80MHz VHT_SS1MCS0 58 | 1 | 1 | <input checked="" type="checkbox"/> | <input checked="" type="checkbox"/> | <input type="checkbox"/> | Pass |
| 4.53 | 11ac 80MHz VHT_SS1MCS0 106 | 1 | 1 | <input checked="" type="checkbox"/> | <input checked="" type="checkbox"/> | <input type="checkbox"/> | Pass |
| 4.54 | 11ac 80MHz VHT_SS1MCS0 122, | 1 | 1 | <input checked="" type="checkbox"/> | <input checked="" type="checkbox"/> | <input type="checkbox"/> | Pass |
| 4.55 | 11ac 80MHz VHT_SS1MCS0 155 | 1 | 1 | <input checked="" type="checkbox"/> | <input checked="" type="checkbox"/> | <input type="checkbox"/> | Pass |
| 4.56 | 11ac 40MHz VHT_SS1_MCS6 46 | 1 | 1 | <input checked="" type="checkbox"/> | <input checked="" type="checkbox"/> | <input type="checkbox"/> | Pass |
| 4.57 | 11ac 40MHz VHT_SS1_MCS6 62 | 1 | 1 | <input checked="" type="checkbox"/> | <input checked="" type="checkbox"/> | <input type="checkbox"/> | Pass |
| 4.58 | 11ac 40MHz VHT_SS1_MCS6 134 | 1 | 1 | <input checked="" type="checkbox"/> | <input checked="" type="checkbox"/> | <input type="checkbox"/> | Pass |
| 4.59 | 11ac 40MHz VHT_SS1_MCS6 159 | 1 | 1 | <input checked="" type="checkbox"/> | <input checked="" type="checkbox"/> | <input type="checkbox"/> | Pass |
| 4.60 | 11a 20MHz 6 Mbit 48 | 1 | 1 | <input checked="" type="checkbox"/> | <input checked="" type="checkbox"/> | <input type="checkbox"/> | Pass |
| 4.61 | 11a 20MHz 6 Mbit 64 | 1 | 1 | <input checked="" type="checkbox"/> | <input checked="" type="checkbox"/> | <input type="checkbox"/> | Pass |
| 4.62 | 11a 20MHz 6 Mbit 140 | 1 | 1 | <input checked="" type="checkbox"/> | <input checked="" type="checkbox"/> | <input type="checkbox"/> | Pass |
| 4.63 | 11a 20MHz 6 Mbit 165 | 1 | 1 | <input checked="" type="checkbox"/> | <input checked="" type="checkbox"/> | <input type="checkbox"/> | Pass |
| 4.64 | 11n 20MHz MCS 0 48 | 1 | 1 | <input checked="" type="checkbox"/> | <input checked="" type="checkbox"/> | <input type="checkbox"/> | Pass |
| 4.65 | 11n 20MHz MCS 0 64 | 1 | 1 | <input checked="" type="checkbox"/> | <input checked="" type="checkbox"/> | <input type="checkbox"/> | Pass |
| 4.66 | 11n 20MHz MCS 0 140 | 1 | 1 | <input checked="" type="checkbox"/> | <input checked="" type="checkbox"/> | <input type="checkbox"/> | Pass |
| 4.67 | 11n 20MHz MCS 0 165 | 1 | 1 | <input checked="" type="checkbox"/> | <input checked="" type="checkbox"/> | <input type="checkbox"/> | Pass |

| Radiated Field Strength Emissions – 1 GHz to 7 GHz | | | | | | | |
|--|--|---|--------------------|-------------------------------------|-------------------------------------|--------------------------|----------------|
| Temperature :+21 °C | | Technology: WLAN 5 GHz 802.11a/n | | TX-Fixed Channel (Modulated) | | | |
| Diagram No. (Remark 1) | Test Settings Mode B.W. Data Rate Channel | Set-up no. | OP-mode no. | Used detector | | | Verdict |
| 4.68 | 11ac 20MHz VHT_SS1_MCS0 48 | 1 | 1 | <input checked="" type="checkbox"/> | <input checked="" type="checkbox"/> | <input type="checkbox"/> | Pass |
| 4.69 | 11ac 20MHz VHT_SS1_MCS0 64 | 1 | 1 | <input checked="" type="checkbox"/> | <input checked="" type="checkbox"/> | <input type="checkbox"/> | Pass |
| 4.70 | 11ac 20MHz VHT_SS1_MCS0 100 | 1 | 1 | <input checked="" type="checkbox"/> | <input checked="" type="checkbox"/> | <input type="checkbox"/> | Pass |
| 4.71 | 11ac 20MHz VHT_SS1_MCS0 149 | 1 | 1 | <input checked="" type="checkbox"/> | <input checked="" type="checkbox"/> | <input type="checkbox"/> | Pass |
| 4.72 | 11n 40MHz MCS1 46 | 1 | 1 | <input checked="" type="checkbox"/> | <input checked="" type="checkbox"/> | <input type="checkbox"/> | Pass |
| 4.73 | 11n 40MHz MCS3 62 | 1 | 1 | <input checked="" type="checkbox"/> | <input checked="" type="checkbox"/> | <input type="checkbox"/> | Pass |
| 4.74 | 11n 40MHz MCS1 102 | 1 | 1 | <input checked="" type="checkbox"/> | <input checked="" type="checkbox"/> | <input type="checkbox"/> | Pass |
| 4.75 | 11n 40MHz MCS5 151 | 1 | 1 | <input checked="" type="checkbox"/> | <input checked="" type="checkbox"/> | <input type="checkbox"/> | Pass |
| Remark 1: See diagrams in separate annex TR17-1-00659T60a-A1 Remark 2: Please refer Chapter 5.1 for applicable Duty-Cycle Correction Factor | | | | | | | |

5.7.5. Radiated Field Strength Emissions – 7 GHz to 18 GHz Results

| Radiated Field Strength Emissions – 7 GHz to 18 GHz | | | | | | | |
|--|--|----------------------------------|-------------|-------------------------------------|-------------------------------------|--------------------------|---------|
| Temperature :+21 °C | | Technology: WLAN 5 GHz 802.11a/n | | TX-Fixed Channel (Modulated) | | | |
| Diagram No. (Remark 1) | Test Settings Mode B.W. Data Rate Channel | Set-up no. | OP-mode no. | Used detector | | | Verdict |
| | | | | PK | AV | QP | |
| 4.51 | 11ac 80MHz VHT_SS1MCS0 42 | 1 | 1 | <input checked="" type="checkbox"/> | <input checked="" type="checkbox"/> | <input type="checkbox"/> | Pass |
| 4.52 | 11ac 80MHz VHT_SS1MCS0 58 | 1 | 1 | <input checked="" type="checkbox"/> | <input checked="" type="checkbox"/> | <input type="checkbox"/> | Pass |
| 4.53 | 11ac 80MHz VHT_SS1MCS0 106 | 1 | 1 | <input checked="" type="checkbox"/> | <input checked="" type="checkbox"/> | <input type="checkbox"/> | Pass |
| 4.54 | 11ac 80MHz VHT_SS1MCS0 122, | 1 | 1 | <input checked="" type="checkbox"/> | <input checked="" type="checkbox"/> | <input type="checkbox"/> | Pass |
| 4.55 | 11ac 80MHz VHT_SS1MCS0 155 | 1 | 1 | <input checked="" type="checkbox"/> | <input checked="" type="checkbox"/> | <input type="checkbox"/> | Pass |
| 4.56 | 11ac 40MHz VHT_SS1_MCS6 46 | 1 | 1 | <input checked="" type="checkbox"/> | <input checked="" type="checkbox"/> | <input type="checkbox"/> | Pass |
| 4.57 | 11ac 40MHz VHT_SS1_MCS6 62 | 1 | 1 | <input checked="" type="checkbox"/> | <input checked="" type="checkbox"/> | <input type="checkbox"/> | Pass |
| 4.58 | 11ac 40MHz VHT_SS1_MCS6 134 | 1 | 1 | <input checked="" type="checkbox"/> | <input checked="" type="checkbox"/> | <input type="checkbox"/> | Pass |
| 4.59 | 11ac 40MHz VHT_SS1_MCS6 159 | 1 | 1 | <input checked="" type="checkbox"/> | <input checked="" type="checkbox"/> | <input type="checkbox"/> | Pass |
| 4.60 | 11a 20MHz 6 Mbit 48 | 1 | 1 | <input checked="" type="checkbox"/> | <input checked="" type="checkbox"/> | <input type="checkbox"/> | Pass |
| 4.61 | 11a 20MHz 6 Mbit 64 | 1 | 1 | <input checked="" type="checkbox"/> | <input checked="" type="checkbox"/> | <input type="checkbox"/> | Pass |
| 4.62 | 11a 20MHz 6 Mbit 140 | 1 | 1 | <input checked="" type="checkbox"/> | <input checked="" type="checkbox"/> | <input type="checkbox"/> | Pass |
| 4.63 | 11a 20MHz 6 Mbit 165 | 1 | 1 | <input checked="" type="checkbox"/> | <input checked="" type="checkbox"/> | <input type="checkbox"/> | Pass |
| 4.64 | 11n 20MHz MCS 0 48 | 1 | 1 | <input checked="" type="checkbox"/> | <input checked="" type="checkbox"/> | <input type="checkbox"/> | Pass |
| 4.65 | 11n 20MHz MCS 0 64 | 1 | 1 | <input checked="" type="checkbox"/> | <input checked="" type="checkbox"/> | <input type="checkbox"/> | Pass |
| 4.66 | 11n 20MHz MCS 0 140 | 1 | 1 | <input checked="" type="checkbox"/> | <input checked="" type="checkbox"/> | <input type="checkbox"/> | Pass |
| 4.67 | 11n 20MHz MCS 0 165 | 1 | 1 | <input checked="" type="checkbox"/> | <input checked="" type="checkbox"/> | <input type="checkbox"/> | Pass |

| Radiated Field Strength Emissions – 7 GHz to 18 GHz | | | | | | | |
|--|--|----------------------------------|-------------|-------------------------------------|-------------------------------------|--------------------------|---------|
| Temperature :+21 °C | | Technology: WLAN 5 GHz 802.11a/n | | TX-Fixed Channel (Modulated) | | | |
| Diagram No. (Remark 1) | Test Settings Mode B.W. Data Rate Channel | Set-up no. | OP-mode no. | Used detector | | | Verdict |
| | | | | PK | AV | QP | |
| 4.68 | 11ac 20MHz VHT_SS1_MCS0 48 | 1 | 1 | <input checked="" type="checkbox"/> | <input checked="" type="checkbox"/> | <input type="checkbox"/> | Pass |
| 4.69 | 11ac 20MHz VHT_SS1_MCS0 64 | 1 | 1 | <input checked="" type="checkbox"/> | <input checked="" type="checkbox"/> | <input type="checkbox"/> | Pass |
| 4.70 | 11ac 20MHz VHT_SS1_MCS0 100 | 1 | 1 | <input checked="" type="checkbox"/> | <input checked="" type="checkbox"/> | <input type="checkbox"/> | Pass |
| 4.71 | 11ac 20MHz VHT_SS1_MCS0 149 | 1 | 1 | <input checked="" type="checkbox"/> | <input checked="" type="checkbox"/> | <input type="checkbox"/> | Pass |
| 4.72 | 11n 40MHz MCS1 46 | 1 | 1 | <input checked="" type="checkbox"/> | <input checked="" type="checkbox"/> | <input type="checkbox"/> | Pass |
| 4.73 | 11n 40MHz MCS3 62 | 1 | 1 | <input checked="" type="checkbox"/> | <input checked="" type="checkbox"/> | <input type="checkbox"/> | Pass |
| 4.74 | 11n 40MHz MCS1 102 | 1 | 1 | <input checked="" type="checkbox"/> | <input checked="" type="checkbox"/> | <input type="checkbox"/> | Pass |
| 4.75 | 11n 40MHz MCS5 151 | 1 | 1 | <input checked="" type="checkbox"/> | <input checked="" type="checkbox"/> | <input type="checkbox"/> | Pass |
| Remark 1: See diagrams in separate annex TR17-1-00659T60a-A1 Remark 2: Please refer Chapter 5.1 for applicable Duty-Cycle Correction Factor | | | | | | | |

5.7.6. Radiated Field Strength Emissions – 18 GHz to 40 GHz Results

| Radiated Field Strength Emissions – 18 GHz to 40 GHz | | | | | | | |
|--|--|----------------------------------|-------------|-------------------------------------|-------------------------------------|--------------------------|---------|
| Temperature :+21 °C | | Technology: WLAN 5 GHz 802.11a/n | | TX-Fixed Channel (Modulated) | | | |
| Diagram No. (Remark 1) | Test Settings Mode B.W. Data Rate Channel | Set-up no. | OP-mode no. | Used detector | | | Verdict |
| | | | | PK | AV | QP | |
| 4.51 | 11ac 80MHz VHT_SS1MCS0 42 | 1 | 1 | <input checked="" type="checkbox"/> | <input checked="" type="checkbox"/> | <input type="checkbox"/> | Pass |
| 4.52 | 11ac 80MHz VHT_SS1MCS0 58 | 1 | 1 | <input checked="" type="checkbox"/> | <input checked="" type="checkbox"/> | <input type="checkbox"/> | Pass |
| 4.53 | 11ac 80MHz VHT_SS1MCS0 106 | 1 | 1 | <input checked="" type="checkbox"/> | <input checked="" type="checkbox"/> | <input type="checkbox"/> | Pass |
| 4.54 | 11ac 80MHz VHT_SS1MCS0 122, | 1 | 1 | <input checked="" type="checkbox"/> | <input checked="" type="checkbox"/> | <input type="checkbox"/> | Pass |
| 4.55 | 11ac 80MHz VHT_SS1MCS0 155 | 1 | 1 | <input checked="" type="checkbox"/> | <input checked="" type="checkbox"/> | <input type="checkbox"/> | Pass |
| 4.56 | 11ac 40MHz VHT_SS1_MCS6 46 | 1 | 1 | <input checked="" type="checkbox"/> | <input checked="" type="checkbox"/> | <input type="checkbox"/> | Pass |
| 4.57 | 11ac 40MHz VHT_SS1_MCS6 62 | 1 | 1 | <input checked="" type="checkbox"/> | <input checked="" type="checkbox"/> | <input type="checkbox"/> | Pass |
| 4.58 | 11ac 40MHz VHT_SS1_MCS6 134 | 1 | 1 | <input checked="" type="checkbox"/> | <input checked="" type="checkbox"/> | <input type="checkbox"/> | Pass |
| 4.59 | 11ac 40MHz VHT_SS1_MCS6 159 | 1 | 1 | <input checked="" type="checkbox"/> | <input checked="" type="checkbox"/> | <input type="checkbox"/> | Pass |
| 4.60 | 11a 20MHz 6 Mbit 48 | 1 | 1 | <input checked="" type="checkbox"/> | <input checked="" type="checkbox"/> | <input type="checkbox"/> | Pass |
| 4.61 | 11a 20MHz 6 Mbit 64 | 1 | 1 | <input checked="" type="checkbox"/> | <input checked="" type="checkbox"/> | <input type="checkbox"/> | Pass |
| 4.62 | 11a 20MHz 6 Mbit 140 | 1 | 1 | <input checked="" type="checkbox"/> | <input checked="" type="checkbox"/> | <input type="checkbox"/> | Pass |
| 4.63 | 11a 20MHz 6 Mbit 165 | 1 | 1 | <input checked="" type="checkbox"/> | <input checked="" type="checkbox"/> | <input type="checkbox"/> | Pass |
| 4.64 | 11n 20MHz MCS 0 48 | 1 | 1 | <input checked="" type="checkbox"/> | <input checked="" type="checkbox"/> | <input type="checkbox"/> | Pass |
| 4.65 | 11n 20MHz MCS 0 64 | 1 | 1 | <input checked="" type="checkbox"/> | <input checked="" type="checkbox"/> | <input type="checkbox"/> | Pass |
| 4.66 | 11n 20MHz MCS 0 140 | 1 | 1 | <input checked="" type="checkbox"/> | <input checked="" type="checkbox"/> | <input type="checkbox"/> | Pass |
| 4.67 | 11n 20MHz MCS 0 165 | 1 | 1 | <input checked="" type="checkbox"/> | <input checked="" type="checkbox"/> | <input type="checkbox"/> | Pass |

| Radiated Field Strength Emissions – 18 GHz to 40 GHz | | | | | | | |
|--|--|----------------------------------|-------------|-------------------------------------|-------------------------------------|--------------------------|---------|
| Temperature :+21 °C | | Technology: WLAN 5 GHz 802.11a/n | | TX-Fixed Channel (Modulated) | | | |
| Diagram No. (Remark 1) | Test Settings Mode B.W. Data Rate Channel | Set-up no. | OP-mode no. | Used detector | | | Verdict |
| | | | | PK | AV | QP | |
| 4.68 | 11ac 20MHz VHT_SS1_MCS0 48 | 1 | 1 | <input checked="" type="checkbox"/> | <input checked="" type="checkbox"/> | <input type="checkbox"/> | Pass |
| 4.69 | 11ac 20MHz VHT_SS1_MCS0 64 | 1 | 1 | <input checked="" type="checkbox"/> | <input checked="" type="checkbox"/> | <input type="checkbox"/> | Pass |
| 4.70 | 11ac 20MHz VHT_SS1_MCS0 100 | 1 | 1 | <input checked="" type="checkbox"/> | <input checked="" type="checkbox"/> | <input type="checkbox"/> | Pass |
| 4.71 | 11ac 20MHz VHT_SS1_MCS0 149 | 1 | 1 | <input checked="" type="checkbox"/> | <input checked="" type="checkbox"/> | <input type="checkbox"/> | Pass |
| 4.72 | 11n 40MHz MCS1 46 | 1 | 1 | <input checked="" type="checkbox"/> | <input checked="" type="checkbox"/> | <input type="checkbox"/> | Pass |
| 4.73 | 11n 40MHz MCS3 62 | 1 | 1 | <input checked="" type="checkbox"/> | <input checked="" type="checkbox"/> | <input type="checkbox"/> | Pass |
| 4.74 | 11n 40MHz MCS1 102 | 1 | 1 | <input checked="" type="checkbox"/> | <input checked="" type="checkbox"/> | <input type="checkbox"/> | Pass |
| 4.75 | 11n 40MHz MCS5 151 | 1 | 1 | <input checked="" type="checkbox"/> | <input checked="" type="checkbox"/> | <input type="checkbox"/> | Pass |
| Remark 1: See diagrams in separate annex TR17-1-00659T60a-A1 Remark 2: Please refer Chapter 5.1 for applicable Duty-Cycle Correction Factor | | | | | | | |

5.8. RF-Parameter - Radiated Band-Edge compliance measurements

5.8.1. Test location and equipment FAR

| | | | | | | |
|-----------------|---|--|--|--|--|----------------------------------|
| test site | <input type="checkbox"/> 441 EMI SAR | <input type="checkbox"/> 348 EMI cond. | <input checked="" type="checkbox"/> 443 EMI FAR | <input type="checkbox"/> 347 Radio.lab. | <input type="checkbox"/> 337 OATS | <input type="checkbox"/> |
| spectr. analys. | <input type="checkbox"/> 584 FSU | <input type="checkbox"/> 120 FSEM | <input type="checkbox"/> 264 FSEK | <input checked="" type="checkbox"/> 489 ESU 40 | <input type="checkbox"/> | <input type="checkbox"/> |
| antenna meas | <input type="checkbox"/> 574 BTA-L | <input type="checkbox"/> 289 CBL 6141 | <input type="checkbox"/> 608 HL 562 | <input checked="" type="checkbox"/> 549 HL025 | <input type="checkbox"/> 302 BBHA9170 | <input type="checkbox"/> 477 GPS |
| antenna meas | <input type="checkbox"/> 123 HUF-Z2 | <input type="checkbox"/> 132 HUF-Z3 | <input type="checkbox"/> 030 HFH-Z2 | <input type="checkbox"/> | <input type="checkbox"/> | <input type="checkbox"/> |
| antenna subst | <input type="checkbox"/> 071 HUF-Z2 | <input type="checkbox"/> 020 EMCO3115 | <input type="checkbox"/> 063 LP 3146 | <input type="checkbox"/> 303 BBHA9170 | <input type="checkbox"/> | <input type="checkbox"/> |
| multimeter | <input type="checkbox"/> 341 Fluke 112 | <input type="checkbox"/> | <input type="checkbox"/> | <input type="checkbox"/> | <input type="checkbox"/> | <input type="checkbox"/> |
| signaling | <input type="checkbox"/> 392 MT8820A | <input type="checkbox"/> 371 CBT32 | <input type="checkbox"/> 547 CMU | <input type="checkbox"/> 594 CMW | <input type="checkbox"/> | <input type="checkbox"/> |
| DC power | <input type="checkbox"/> 611 E3632A | <input type="checkbox"/> 087 EA3013 | <input type="checkbox"/> 354 NGPE 40 | <input type="checkbox"/> 349 car battery | <input type="checkbox"/> 350 Car battery | <input type="checkbox"/> |
| Supply voltage | <input type="checkbox"/> 230 V 50 Hz via public mains | | <input checked="" type="checkbox"/> 4.20 V DC (fully charged internal battery) | | | |

5.8.2. Requirements/Limits

| | | | | |
|---|---|----------------|----------------|---|
| FCC | <input type="checkbox"/> Part 15 Subpart B, §15.109 class B <input checked="" type="checkbox"/> Part 15 Subpart C, §15.209 for frequencies defined in §15.205 <input checked="" type="checkbox"/> Part 15 Subpart C, §15.407(b)(1)(2)(3)(4)(5)(6)(7)(8) | | | |
| ANSI | <input type="checkbox"/> C63.4-2014 <input checked="" type="checkbox"/> C63.10-2013 Chapter 6.10.6 | | | |
| Frequency [MHz] | Limits | | | |
| | AV [µV/m] | AV [dBµV/m] | Peak [µV/m] | Peak [dBµV/m] or [dBm/MHz] |
| above 1 GHz for frequencies as defined in §15.205 | 500 | 54.0 | 5000 | 74.0 dBµV/m |
| §15.407(b)(1)(2)(3)(4) | -- | -- | -- | (b)(1): 5.15-5.25GHz: -27dBm eirp (b)(2): 5.25-5.35GHz: -27dBm eirp (b)(3): 5.47-5.725 GHz: -27dBm eirp (b)(4): 5.725-5.85GHz: Spectrum mask |

5.8.3. Test condition and measurement test set-up

| | | | |
|---------------------------------------|---|--|--|
| Signal link to test system (if used): | <input type="checkbox"/> air link | <input type="checkbox"/> cable connection | <input checked="" type="checkbox"/> none |
| EUT-grounding | <input checked="" type="checkbox"/> none | <input type="checkbox"/> with power supply | <input type="checkbox"/> additional connection |
| Equipment set up | <input checked="" type="checkbox"/> table top 1.5m height | | <input type="checkbox"/> floor standing |
| Climatic conditions | Temperature: (22±3°C) | | Rel. humidity: (40±20)% |
| Spectrum-Analyzer settings | Scan frequency range: <input type="checkbox"/> 1 – 18 GHz <input type="checkbox"/> 18 – 25 GHz <input type="checkbox"/> 18 – 40 GHz <input checked="" type="checkbox"/> other: see diagrams <input type="checkbox"/> 6 dB EMI-Receiver Mode <input checked="" type="checkbox"/> 3 dB Spectrum analyzer Mode Peak and Average Left band-edge: 100kHz/300kHz Right band-edge: 1 MHz / 3 MHz Repetitive-Scan, max-hold Mode: Scan step 40kHz or 400 kHz Coupled – calibrated display if CW signal otherwise adapted to EUT’s individual duty-cycle | | |
| General measurement procedures | Please see chapter “Test system set-up for radiated electric field measurements above 1 GHz” for general measurements procedures in anechoic chamber. | | |

5.8.4. Measurement Method

For uncritical results where a measurement resolution bandwidth of 1MHz can clearly show the compliance without influencing the results, a field strength measurement was performed to show compliance.

For critical results a Marker-Delta marker method was used for showing compliance to restricted bands. The method is according ANSI C63.10:2013, Chapter 6.10.6 “Marker-Delta method”,. The method consists of three independent steps:

- 1. Step:** Prior to the measurement the fundamental radiated In-Band field strength was performed. The determined value is used as reference value.
- 2. Step:** Second step consist of finding the relative attenuation between the fundamental emission and the maximum local out-of-band emission (within 2 MHz range around the band edge either on the band-edge directly or some modulation product if the level is greater than that on the band-edge) when measured with lower resolution bandwidth.
- 3. Step:** The delta value recorded in step 2 will be subtracted from value recorded in step 1, thus giving the required field strength at the band-edge. This value must fulfil the requirements for radiated spurious emissions in restricted bands in FCC §15.205 with the general limits of FCC §15.209.

5.8.5. EUT settings

The EUT was instructed to send with maximum power (if adjustable) according to applicants instructions.

5.8.6. Results for non-restricted bands near-by

5.8.6.1. Non-restricted bands near-by - limits according to FCC §15.407 limits

| Technology: | | WLAN 5 GHz 802.11a Mode B.W. 20 MHz | | | | | | | |
|-------------|-------------|-------------------------------------|----------------------------|--|----------------------------------|---------------------|--------------|-------------|-----------------------------------|
| Set-up No.: | | 1 | | | | | | | |
| Op. Mode: | | 1/2 | | | | | | | |
| Diagram no. | Channel no. | Restricted band ? | Fundamental Value [dBuV/m] | | Peak-Value at Band-Edge [dBuV/m] | Limit: [dBuV/m @3m] | Margin: [dB] | Verdict | Remark: Mode-B.W.-Data Rate-Power |
| | | | Peak -Value | Average -Value + Duty Cycle Correction | | | | | |
| 9.02 | 5240 | NO | 103,00 | 98,27 | 53,73 | 68,20 | 14,47 | PASS | a-Mode-20 MHz-6Mbit+14dBm |
| 9.03 | 5260 | NO | 94,60 | not measured | 62,25 | 68,20 | 5,95 | PASS | a-Mode-20 MHz-6Mbit+10dBm |
| 9.05 | 5500 | NO | 102,83 | 98,11 | 55,30 | 68,20 | 12,90 | PASS | a-Mode-20 MHz-6Mbit+10dBm |
| 9.33b | 5700 | NO | 99,77 | 95,43 | 52,66 | 68,20 | 15,54 | PASS | a-Mode-20 MHz-6Mbit+10dBm |
| 9.34a | 5745 | NO | 100,44 | 92,25 | 58,97 | 68,20 | 9,23 | PASS | a-Mode-20 MHz-6Mbit+10dBm |
| 9.34b | 5825 | NO | 99,73 | 95,03 | | 68,20 | 68,20 | PASS | a-Mode-20 MHz-6Mbit+10dBm |

Remark 1: For further details please refer → Annex 1: Test results - CETECOM_TR17-1-0065901T60-A1

Remark 2: Measurements results are only valid and compliant with power setting: +10 dBm

Remark 3: Please refer Chapter 5.1 for applicable Duty-Cycle Correction Factor

| | | | | | | | | | |
|-------------|-------------------------------------|--|--|--|--|--|--|--|--|
| Technology: | WLAN 5 GHz 802.11n Mode B.W. 20 MHz | | | | | | | | |
| Set-up No.: | 1 | | | | | | | | |
| Op. Mode: | 1/2 | | | | | | | | |

| Diagram no. | Channel no. | Restricted band ? | Fundamental Value [dBuV/m] | | Peak-Value at Band-Edge [dBuV/m] | Limit: [dBuV/m @3m] | Margin: [dB] | Verdict | Remark: Mode-B.W.-Data Rate-Power |
|-------------|-------------|-------------------|----------------------------|--|----------------------------------|---------------------|--------------|---------|-----------------------------------|
| | | | Peak -Value | Average -Value + Duty Cycle Correction | | | | | |
| 9.10 | 5240 | NO | 101,61 | 97,95 | 43,10 | 68,20 | 25,10 | PASS | n-Mode-20 MHz-MCS0+10dBm |
| 9.11b | 5260 | NO | 93,94 | Not measured | 65,18 | 68,20 | 3,02 | PASS | n-Mode-20 MHz-MCS0+10dBm |
| 9.13 | 5500 | NO | 103,21 | 94,96 | 55,90 | 68,20 | 12,30 | PASS | n-Mode-20 MHz-MCS0+10dBm |
| 9.14 | 5700 | NO | 100,48 | 96,41 | 53,30 | 68,20 | 14,90 | PASS | n-Mode-20 MHz-MCS0+10dBm |
| 9.15 | 5745 | NO | 99,03 | 94,86 | 65,00 | 122,20 | 57,20 | PASS | n-Mode-20 MHz-MCS0+10dBm |
| 9.16 | 5825 | NO | 99,37 | 95,71 | 55,03 | 122,20 | 67,17 | PASS | n-Mode-20 MHz-MCS0+10dBm |

Remark 1: For further details please refer → Annex 1: Test results - CETECOM_TR17-1-0065901T60-A1
 Remark 2: Measurements results are only valid and compliant with power setting: +10 dBm
 Remark 3: Please refer Chapter 5.1 for applicable Duty-Cycle Correction Factor

| | | | | | | | | | |
|-------------|--------------------------------------|--|--|--|--|--|--|--|--|
| Technology: | WLAN 5 GHz 802.11ac Mode B.W. 20 MHz | | | | | | | | |
| Set-up No.: | 1 | | | | | | | | |
| Op. Mode: | 1/2 | | | | | | | | |

| Diagram no. | Channel no. | Restricted band ? | Fundamental Value [dBuV/m] | | Peak-Value at Band-Edge [dBuV/m] | Limit: [dBuV/m @3m] | Margin: [dB] | Verdict | Remark: Mode-B.W.-Data Rate-Power |
|-------------|-------------|-------------------|----------------------------|--|----------------------------------|---------------------|--------------|---------|-----------------------------------|
| | | | Peak -Value | Average -Value + Duty Cycle Correction | | | | | |
| 9.18 | 5240 | NO | 111,26 | 102,26 | 53,30 | 68,20 | 14,90 | PASS | a-Mode-20 MHz-MCS0+6dBm |
| 9.19b | 5260 | NO | 89,32 | not measured | 58,91 | 68,20 | 9,29 | PASS | a-Mode-20 MHz-MCS0+6dBm |
| 9.21 | 5500 | NO | 98,35 | 90,14 | 53,30 | 68,20 | 14,90 | PASS | a-Mode-20 MHz-MCS0+6dBm |
| 9.22 | 5700 | NO | 96,00 | 86,86 | 53,34 | 68,20 | 14,86 | PASS | a-Mode-20 MHz-MCS0+6dBm |
| 9.23 | 5745 | NO | 95,24 | 87,51 | 55,90 | 122,20 | 66,30 | PASS | a-Mode-20 MHz-MCS0+6dBm |
| 9.24 | 5825 | NO | 94,82 | 87,26 | 55,04 | 122,20 | 67,16 | PASS | a-Mode-20 MHz-MCS0+6dBm |

Remark 1: For further details please refer → Annex 1: Test results - CETECOM_TR17-1-0065901T60-A1
 Remark 2: Measurements results are only valid and compliant with power setting: +6 dBm
 Remark 3: Please refer Chapter 5.1 for applicable Duty-Cycle Correction Factor

| | | | | | | | | | |
|-------------|-------------------------------------|--|--|--|--|--|--|--|--|
| Technology: | WLAN 5 GHz 802.11n Mode B.W. 40 MHz | | | | | | | | |
| Set-up No.: | 1 | | | | | | | | |
| Op. Mode: | 1/2 | | | | | | | | |

| Diagram no. | Channel no. | Restricted band ? | Fundamental Value [dBuV/m] | | Peak-Value at Band-Edge [dBuV/m] | Limit: [dBuV/m @3m] | Margin: [dB] | Verdict | Remark: Mode-B.W.-Data Rate-Power |
|-------------|-------------|-------------------|----------------------------|--|----------------------------------|---------------------|--------------|---------|-----------------------------------|
| | | | Peak -Value | Average -Value + Duty Cycle Correction | | | | | |
| 9.26 | 5230 | NO | 96,20 | 87,24 | 52,52 | 68,20 | 15,68 | PASS | n-Mode-40 MHz-MCS1+10dBm |
| 9.27b | 5270 | NO | 85,71 | not measured | 57,20 | 68,20 | 11,00 | PASS | n-Mode-40 MHz-MCS3+10dBm |
| 9.29 | 5510 | NO | 98,83 | 89,42 | 58,50 | 68,20 | 9,70 | PASS | n-Mode-40 MHz-MCS1+10dBm |
| 9.30 | 5670 | NO | 97,83 | 88,51 | 52,00 | 68,20 | 16,20 | PASS | n-Mode-40 MHz-MCS1+10dBm |
| 9.31 | 5755 | NO | 96,85 | 87,21 | 59,03 | 122,20 | 63,17 | PASS | n-Mode-40 MHz-MCS5+10dBm |
| 9.32 | 5795 | NO | 95,54 | 84,86 | 55,65 | 122,20 | 66,55 | PASS | n-Mode-40 MHz-MCS5+10dBm |

Remark 1: For further details please refer → Annex 1: Test results - CETECOM_TR17-1-0065901T60-A1
 Remark 2: Measurements results are only valid and compliant with power setting: +10 dBm
 Remark 3: Please refer Chapter 5.1 for applicable Duty-Cycle Correction Factor

| | | | | | | | | | |
|-------------|--------------------------------------|--|--|--|--|--|--|--|--|
| Technology: | WLAN 5 GHz 802.11ac Mode B.W. 40 MHz | | | | | | | | |
| Set-up No.: | 1 | | | | | | | | |
| Op. Mode: | 1/2 | | | | | | | | |

| Diagram no. | Channel no. | Restricted band ? | Fundamental Value [dBuV/m] | | Peak-Value at Band-Edge [dBuV/m] | Limit: [dBuV/m @3m] | Margin: [dB] | Verdict | Remark: Mode-B.W.-Data Rate-Power |
|-------------|-------------|-------------------|----------------------------|--|----------------------------------|---------------------|--------------|---------|-----------------------------------|
| | | | Peak -Value | Average -Value + Duty Cycle Correction | | | | | |
| 9.34 | 5230 | NO | 92,83 | 83,37 | 51,74 | 68,20 | 16,46 | PASS | ac-Mode-40 MHz-MCS0+6dBm |
| 9.35 | 5270 | NO | 79,94 | Not measured | 62,45 | 68,20 | 5,75 | PASS | ac-Mode-40 MHz-MCS0+6dBm |
| 9.37 | 5510 | NO | 94,71 | 84,02 | 51,06 | 68,20 | 17,14 | PASS | ac-Mode-40 MHz-MCS0+6dBm |
| 9.38 | 5670 | NO | 92,32 | 83,89 | 53,30 | 68,20 | 14,90 | PASS | ac-Mode-40 MHz-MCS0+6dBm |
| 9.39 | 5755 | NO | 92,89 | 83,91 | 54,60 | 122,20 | 67,60 | PASS | ac-Mode-40 MHz-MCS0+6dBm |
| 9.40 | 5795 | NO | 93,01 | 84,88 | 56,30 | 122,20 | 65,90 | PASS | ac-Mode-40 MHz-MCS0+6dBm |

Remark 1: For further details please refer → Annex 1: Test results - CETECOM_TR17-1-0065901T60-A1
 Remark 2: Measurements results are only valid and compliant with power setting: +6 dBm
 Remark 3: Please refer Chapter 5.1 for applicable Duty-Cycle Correction Factor

| | |
|-------------|--------------------------------------|
| Technology: | WLAN 5 GHz 802.11ac Mode B.W. 80 MHz |
| Set-up No.: | 1 |
| Op. Mode: | 1/2 |

| Diagram no. | Channel no. | Restricted band ? | Fundamental Value [dBuV/m] | | Peak-Value at Band-Edge [dBuV/m] | Limit: [dBuV/m @3m] | Margin: [dB] | Verdict | Remark: Mode-B.W.-Data Rate-Power |
|-------------|-------------|-------------------|----------------------------|--|----------------------------------|---------------------|--------------|---------|-----------------------------------|
| | | | Peak -Value | Average -Value + Duty Cycle Correction | | | | | |
| 9.41a | 5210 | NO | 91,83 | 82,84 | 57,51 | 68,20 | 10,69 | PASS | n-Mode-80 MHz-MCS0+6dBm |
| 9.42b | 5290 | NO | 82,12 | not measured | 52,63 | 68,20 | 15,57 | PASS | n-Mode-80 MHz-MCS0+6dBm |
| 9.43 | 5530 | NO | 92,26 | 84,55 | 58,90 | 68,20 | 9,30 | PASS | n-Mode-80 MHz-MCS0+6dBm |
| 9.44 | 5610 | NO | not measured | not measured | 50,70 | 68,20 | 17,50 | PASS | n-Mode-80 MHz-MCS0+6dBm |
| 9.45a | 5775 | NO | 81,39 | 87,71 | 55,72 | 122,20 | 66,48 | PASS | n-Mode-80 MHz-MCS0+6dBm |
| 9.45b | 5775 | NO | 87,44 | 77,06 | 53,34 | 122,20 | 68,86 | PASS | n-Mode-80 MHz-MCS0+6dBm |

Remark 1: For further details please refer → Annex 1: Test results - CETECOM_TR17-1-0065901T60-A1
 Remark 2: Measurements results are only valid and compliant with power setting: +6 dBm
 Remark 3: Please refer Chapter 5.1 for applicable Duty-Cycle Correction Factor

5.8.6.2. Results for restricted bands near-by with limits accord. FCC §15.205 §15.209

| Technology: | | WLAN 5 GHz 802.11a Mode B.W. 20 MHz | | | | | | | | | | |
|-------------|-------------|-------------------------------------|----------------------------|--|-----------------------------|--|-----------------|----------------|-------------|---------|---------|--------------------------------------|
| Set-up No.: | | 1 | | | | | | | | | | |
| Op. Mode: | | 1/2 | | | | | | | | | | |
| Diagram no. | Channel no. | Restricted band ? | Fundamental Value [dBuV/m] | | Value at Band-Edge [dBuV/m] | | Limits [dBuV/m] | | Margin [dB] | | Verdict | Remark: Mode-B.W.-Data Rate-Power |
| | | | Peak -Value | Average -Value + Duty Cycle Correction | Peak -Value | Average -Value + Duty Cycle Correction | Peak -Value | Average -Value | Peak | Average | | |
| 9.01 | 5180 | YES | 103,62 | 99,26 | 55,79 | 47,45 | 74,00 | 54,00 | 18,21 | 6,55 | PASS | a-Mode-20 MHz-6Mbit+10dBm |
| 9.04 | 5320 | YES | 103,03 | 98,24 | 54,80 | 48,32 | 74,00 | 54,00 | 19,21 | 5,68 | PASS | a-Mode-20 MHz-6Mbit+10dBm |

Remark 1: For further details please refer → Annex 1: Test results - CETECOM_TR17-1-0065901T60-A1
 Remark 2: Measurements results are only valid and compliant with power setting: +10 dBm
 Remark 3: Please refer Chapter 5.1 for applicable Duty-Cycle Correction Factor

| Technology: | | WLAN 5 GHz 802.11n Mode B.W. 20 MHz | | | | | | | | | | |
|-------------|-------------|-------------------------------------|----------------------------|--|-----------------------------|--|-----------------|----------------|-------------|---------|---------|--------------------------------------|
| Set-up No.: | | 1 | | | | | | | | | | |
| Op. Mode: | | 1/2 | | | | | | | | | | |
| Diagram no. | Channel no. | Restricted band ? | Fundamental Value [dBuV/m] | | Value at Band-Edge [dBuV/m] | | Limits [dBuV/m] | | Margin [dB] | | Verdict | Remark: Mode-B.W.-Data Rate-Power |
| | | | Peak -Value | Average -Value + Duty Cycle Correction | Peak -Value | Average -Value + Duty Cycle Correction | Peak -Value | Average -Value | Peak | Average | | |
| 9.09 | 5180 | YES | 102,56 | 98,57 | 54,73 | 48,27 | 74,00 | 54,00 | 19,27 | 5,73 | PASS | n-Mode-20 MHz-MCS0+10dBm |
| 9.12 | 5320 | YES | 102,26 | 98,28 | 56,49 | 49,04 | 74,00 | 54,00 | 17,51 | 4,97 | PASS | n-Mode-20 MHz-MCS0+10dBm |

Remark 1: For further details please refer → Annex 1: Test results - CETECOM_TR17-1-0065901T60-A1
 Remark 2: Measurements results are only valid and compliant with power setting: +10 dBm
 Remark 3: Please refer Chapter 5.1 for applicable Duty-Cycle Correction Factor

| Technology: | | WLAN 5 GHz 802.11ac Mode B.W. 20 MHz | | | | | | | | | | |
|-------------|-------------|--------------------------------------|----------------------------|--|-----------------------------|--|-----------------|----------------|-------------|---------|---------|--------------------------------------|
| Set-up No.: | | 1 | | | | | | | | | | |
| Op. Mode: | | 1/2 | | | | | | | | | | |
| Diagram no. | Channel no. | Restricted band ? | Fundamental Value [dBuV/m] | | Value at Band-Edge [dBuV/m] | | Limits [dBuV/m] | | Margin [dB] | | Verdict | Remark: Mode-B.W.-Data Rate-Power |
| | | | Peak -Value | Average -Value + Duty Cycle Correction | Peak -Value | Average -Value + Duty Cycle Correction | Peak -Value | Average -Value | Peak | Average | | |
| 9.17 | 5180 | YES | 96,95 | 93,95 | 53,05 | 42,77 | 74,00 | 54,00 | 20,95 | 11,23 | PASS | a-Mode-20 MHz-MCS0+6dBm |
| 9.20 | 5320 | YES | 104,84 | 100,98 | 58,50 | 49,73 | 74,00 | 54,00 | 15,50 | 4,27 | PASS | a-Mode-20 MHz-MCS0+6dBm |

Remark 1: For further details please refer → Annex 1: Test results - CETECOM_TR17-1-0065901T60-A1
 Remark 2: Measurements results are only valid and compliant with power setting: +6 dBm
 Remark 3: Please refer Chapter 5.1 for applicable Duty-Cycle Correction Factor

| | | | | | | | | | | | |
|-------------|-------------------------------------|--|--|--|--|--|--|--|--|--|--|
| Technology: | WLAN 5 GHz 802.11n Mode B.W. 40 MHz | | | | | | | | | | |
| Set-up No.: | 1 | | | | | | | | | | |
| Op. Mode: | 1/2 | | | | | | | | | | |

| Diagram no. | Channel no. | Restricted band ? | Fundamental Value [dBuV/m] | | Value at Band-Edge [dBuV/m] | | Limits [dBuV/m] | | Margin [dB] | | Verdict | Remark: Mode-B.W.-Data Rate-Power |
|-------------|-------------|-------------------|----------------------------|--|-----------------------------|--|-----------------|----------------|-------------|---------|---------|-----------------------------------|
| | | | Peak -Value | Average -Value + Duty Cycle Correction | Peak -Value | Average -Value + Duty Cycle Correction | Peak -Value | Average -Value | Peak | Average | | |
| 9.25 | 5190 | YES | 90,03 | 77,21 | 62,40 | 45,53 | 74,00 | 54,00 | 11,60 | 8,47 | PASS | n-Mode-40 MHz-MCS1+10dBm |
| 9.28 | 5310 | YES | 95,74 | 87,29 | 56,80 | 46,93 | 74,00 | 54,00 | 17,20 | 7,07 | PASS | n-Mode-40 MHz-MCS3+10dBm |

Remark 1: For further details please refer → Annex 1: Test results - CETECOM_TR17-1-0065901T60-A1
 Remark 2: Measurements results are only valid and compliant with power setting: +10 dBm
 Remark 3: Please refer Chapter 5.1 for applicable Duty-Cycle Correction Factor

| | | | | | | | | | | | |
|-------------|--------------------------------------|--|--|--|--|--|--|--|--|--|--|
| Technology: | WLAN 5 GHz 802.11ac Mode B.W. 40 MHz | | | | | | | | | | |
| Set-up No.: | 1 | | | | | | | | | | |
| Op. Mode: | 1/2 | | | | | | | | | | |

| Diagram no. | Channel no. | Restricted band ? | Fundamental Value [dBuV/m] | | Value at Band-Edge [dBuV/m] | | Limits [dBuV/m] | | Margin [dB] | | Verdict | Remark: Mode-B.W.-Data Rate-Power |
|-------------|-------------|-------------------|----------------------------|--|-----------------------------|--|-----------------|----------------|-------------|---------|---------|-----------------------------------|
| | | | Peak -Value | Average -Value + Duty Cycle Correction | Peak -Value | Average -Value + Duty Cycle Correction | Peak -Value | Average -Value | Peak | Average | | |
| 9.33 | 5190 | YES | 91,91 | 83,27 | 50,96 | 41,60 | 74,00 | 54,00 | 23,04 | 12,40 | PASS | ac-Mode-40 MHz-MCS0+6dBm |
| 9.36 | 5310 | YES | 95,65 | 83,73 | 54,60 | 42,90 | 74,00 | 54,00 | 19,40 | 11,10 | PASS | ac-Mode-40 MHz-MCS0+6dBm |

Remark 1: For further details please refer → Annex 1: Test results - CETECOM_TR17-1-0065901T60-A1
 Remark 2: Measurements results are only valid and compliant with power setting: +6 dBm
 Remark 3: Please refer Chapter 5.1 for applicable Duty-Cycle Correction Factor

| | | | | | | | | | | | |
|-------------|--------------------------------------|--|--|--|--|--|--|--|--|--|--|
| Technology: | WLAN 5 GHz 802.11ac Mode B.W. 80 MHz | | | | | | | | | | |
| Set-up No.: | 1 | | | | | | | | | | |
| Op. Mode: | 1/2 | | | | | | | | | | |

| Diagram no. | Channel no. | Restricted band ? | Fundamental Value [dBuV/m] | | Value at Band-Edge [dBuV/m] | | Limits [dBuV/m] | | Margin [dB] | | Verdict | Remark: Mode-B.W.-Data Rate-Power |
|-------------|-------------|-------------------|----------------------------|--|-----------------------------|--|-----------------|----------------|-------------|---------|---------|-----------------------------------|
| | | | Peak -Value | Average -Value + Duty Cycle Correction | Peak -Value | Average -Value + Duty Cycle Correction | Peak -Value | Average -Value | Peak | Average | | |
| 9.41b | 5210 | YES | 91,79 | 82,77 | 51,80 | 40,74 | 74,00 | 54,00 | 22,20 | 13,26 | PASS | n-Mode-80 MHz-MCS0+6dBm |
| 9.42d | 5290 | YES | 91,34 | 81,40 | 55,24 | 42,90 | 74,00 | 54,00 | 18,76 | 11,10 | PASS | n-Mode-80 MHz-MCS0+6dBm |

Remark 1: For further details please refer → Annex 1: Test results - CETECOM_TR17-1-0065901T60-A1
 Remark 2: Measurements results are only valid and compliant with power setting: +6 dBm
 Remark 3: Please refer Chapter 5.1 for applicable Duty-Cycle Correction Factor

5.8.7. Verdict: Pass

5.9. Measurement uncertainties

The reported uncertainties are calculated based on the standard uncertainty multiplied with the appropriate coverage factor **k**, such that a confidence level of approximately 95% is achieved.

For uncertainty determination, each component used in the concrete measurement set-up was taken in account and it's contribution to the overall uncertainty according it's statistical distribution calculated.

Following table shows expectable uncertainties for each measurement type performed.

| RF-Measurement | Reference | Frequency range | Calculated uncertainty based on a confidence level of 95% | | | | | | Remarks |
|--|--------------|--------------------|---|--------|------|------|------|----|---|
| Conducted emissions (U _{CISPR}) | CISPR 16-2-1 | 9 kHz - 150 kHz | 4.0 dB | | | | | | - |
| | | 150 kHz - 30 MHz | 3.6 dB | | | | | | |
| Radiated emissions Enclosure | CISPR 16-2-3 | 30 MHz - 1 GHz | 4.2 dB | | | | | | E-Field |
| | | 1 GHz - 18 GHz | 5.1 dB | | | | | | |
| Disturbance power | CISPR 16-2-2 | 30 MHz - 300 MHz | - | | | | | | - |
| Power Output radiated | - | 30 MHz - 4 GHz | 3.17 dB | | | | | | Substitution method |
| Power Output conducted | - | Set-up No. | Cel-C1 | Cel-C2 | BT1 | W1 | W2 | -- | - |
| | | 9 kHz - 12.75 GHz | N/A | 0.60 | 0.7 | 0.25 | N/A | -- | |
| | | 12.75 - 26.5GHz | N/A | 0.82 | -- | N/A | N/A | -- | |
| Conducted emissions on RF-port | - | 9 kHz - 2.8 GHz | 0.70 | N/A | 0.70 | N/A | 0.69 | -- | N/A - not applicable |
| | | 2.8 GHz - 12.75GHz | 1.48 | N/A | 1.51 | N/A | 1.43 | -- | |
| | | 12.75 GHz - 18GHz | 1.81 | N/A | 1.83 | N/A | 1.77 | -- | |
| | | 18 GHz - 26.5GHz | 1.83 | N/A | 1.85 | N/A | 1.79 | -- | |
| Occupied bandwidth | - | 9 kHz - 4 GHz | 0.1272 ppm (Delta Marker) | | | | | | Frequency error |
| | | | 1.0 dB | | | | | | Power |
| Emission bandwidth | - | 9 kHz - 4 GHz | 0.1272 ppm (Delta Marker) | | | | | | Frequency error |
| | | | See above: 0.70 dB | | | | | | Power |
| Frequency stability | - | 9 kHz - 20 GHz | 0.0636 ppm | | | | | | - |
| Radiated emissions Enclosure | - | 150 kHz - 30 MHz | 5.0 dB | | | | | | Magnetic field E-field Substitution |
| | | 30 MHz - 1 GHz | 4.2 dB | | | | | | |
| | | 1 GHz - 20 GHz | 3.17 dB | | | | | | |

Table: measurement uncertainties, valid for conducted/radiated measurements

6. Abbreviations used in this report

| The abbreviations | |
|-------------------|---|
| ANSI | American National Standards Institute |
| AV . AVG. CAV | Average detector |
| EIRP | Equivalent isotropically radiated power. determined within a separate measurement |
| EGPRS | Enhanced General Packet Radio Service |
| EUT | Equipment Under Test |
| FCC | Federal Communications Commission. USA |
| IC | Industry Canada |
| n.a. | not applicable |
| Op-Mode | Operating mode of the equipment |
| PK | Peak |
| RBW | resolution bandwidth |
| RF | Radio frequency |
| RSS | Radio Standards Specification. Documents from Industry Canada |
| Rx | Receiver |
| TCH | Traffic channel |
| Tx | Transmitter |
| QP | Quasi peak detector |
| VBW | Video bandwidth |
| ERP | Effective radiated power |

7. Accreditation details of CETECOM's laboratories and test sites

| Ref.- No. | Accreditation Certificate | Valid for laboratory area or test site | Accreditation Body |
|---------------------------------|--|---|---|
| - | D-PL-12047-01-01 | All laboratories and test sites of CETECOM GmbH. Essen | DAkkS. Deutsche Akkreditierungsstelle GmbH |
| 337 487 558 348 348 | (MRA US-EU 0003) | Radiated Measurements 30 MHz to 1 GHz. 3 m / 10 m (OATS) Radiated Measurements 30 MHz to 1 GHz. 3 m (SAR) Radiated Measurements above 1 GHz. 3 m (FAR) Mains Ports Conducted Interference Measurements Telecommunication Ports Conducted Interference Measur. | FCC. Federal Communications Commission Laboratory Division. USA |
| 337 487 550 558 | 3462D-1 3462D-2 3462D-2 3462D-3 | Radiated Measurements 30 MHz to 1 GHz. 3 m / 10 m (OATS) Radiated Measurements 30 MHz to 1 GHz. 3 m (SAR) Radiated Measurements 1 GHz to 6 GHz. 3 m (SAR) Radiated Measurements above 1 GHz. 3 m (FAR) | IC. Industry Canada Certification and Engineering Bureau |
| 487 550 348 348 | R-2666 G-301 C-2914 T-1967 | Radiated Measurements 30 MHz to 1 GHz. 3 m (SAR) Radiated Measurements 1 GHz to 6 GHz. 3 m (SAR) Mains Ports Conducted Interference Measurements Telecommunication Ports Conducted Interference Measur. | VCCI. Voluntary Control Council for Interference by Information Technology Equipment. Japan |

OATS = Open Area Test Site. SAR = Semi Anechoic Room. FAR = Fully Anechoic Room

8. Instruments and Ancillary

TC”

The “Ref.-No” in the left column of the following tables allows the clear identification of the laboratory equipment.

8.1.1. Test software and firmware of equipment

| Ref.-No. | Equipment | Type | Serial-No. | Version of Firmware or Software during the test |
|----------|---|------------------------|----------------|---|
| 001 | EMI Test Receiver | ESS | 825132/017 | Firm.= 1.21 , OTP=2.0, GRA=2.0 |
| 012 | Signal Generator (EMS-cond.) | SMY 01 | 839069/027 | Firm.= V 2.02 |
| 013 | Power Meter (EMS cond.) | NRVD | 839111/003 | Firm.= V 1.51 |
| 017 | Digital Radiocommunication Tester | CMD 60 M | 844365/014 | Firmware = V 3.52 .22.01.99, DECT = D2.87 13.01.99 |
| 053 | Audio Analyzer | UPA3 | 860612/022 | Firm. V 4.3 |
| 119 | RT Harmonics Analyzer dig. Flickermeter | B10 | G60547 | Firm.= V 3.1DHG |
| 140 | Signal Generator | SMHU | 831314/006 | Firm.= 3.21 |
| 261 | Thermal Power Sensor | NRV-Z55 | 825083/0008 | EPROM-Datum 02.12.04, SE EE 1 B |
| 262 | Power Meter | NRV-S | 825770/0010 | Firm.= 2.6 |
| 263 | Signal Generator | SMP 04 | 826190/0007 | Firm.=3.21 |
| 295 | Racal Digital Radio Test Set | 6103 | 1572 | UNIT Firmware= 4.04, SW-Main=4.04, SW-BBP=1.04, SW-DSP=1.02, Hardboot=1.02, Softboot=2.02 |
| 298 | Univ. Radio Communication Tester | CMU 200 | 832221/091 | R&S Test Firmware =3.53 /3.54 (current Testsoftw. f. all band used |
| 323 | Digital Radiocommunication Tester | CMD 55 | 825878/0034 | Firm.= 3.52 .22.01.99 |
| 335 | CTC-EMS-Conducted | System EMS Conducted | - | EMC 32 V 8.52 |
| 340 | Digital Radiocommunication Tester | CMD 55 | 849709/037 | Firm.= 3.52 .22.01.99 |
| 355 | Power Meter | URV 5 | 891310/027 | Firm.= 1.31 |
| 365 | 10V Insertion Unit 50 Ohm | URV5-Z2 | 100880 | Eprom Data = 31.03.08 |
| 366 | Ultra Compact Simulator | UCS 500 M4 | V0531100594 | Firm. UCS 500=001925/3.06a02, rc=ISMIEC 4.10 |
| 371 | Bluetooth Tester | CBT32 | 100153 | CBT V5.30+ SW-Option K55, K57 |
| 377 | EMI Test Receiver | ESCS 30 | 100160 | Firm.= 2.30, OTP= 02.01, GRA= 02.36 |
| 378 | Broadband RF Field Monitor | RadiSense III | 03D00013SNO-08 | Firm.= V.03D13 |
| 389 | Digital Multimeter | Keithley 2000 | 0583926 | Firm. = A13 (Mainboard) A02 (Display) |
| 392 | Radio Communication Tester | MT8820A | 6K00000788 | Firm.= 4.50 #005, IPL=4.01#001, OS=4.02#001, GSM=4.41#013, W-CDMA= 4.54#004, scenario= 4.52#002 |
| 436 | Univ. Radio Communication Tester | CMU 200 | 103083 | R&S Test Firmware Base=5.14, Mess-Software= GSM:5.14 WCDMA:5.14 (current Testsoftw. F. all band |
| 441 | CTC-SAR-EMI Cable Loss | System EMI field (SAR) | - | EMC 32 Version 8.52 |
| 442 | CTC-SAR-EMS | System EMS field (SAR) | - | EMC 32 Version 8.40 |
| 443 | CTC-FAR-EMI-RSE | System CTC-FAR-EMI-RSE | - | Spuri 7.2.5 or EMC 32 Ver. 9.15.00 |
| 444 | CTC-FAR-EMS field | System-EMS-Field (FAR) | - | EMC 32 Version 9.15.00 |
| 460 | Univ. Radio Communication Tester | CMU 200 | 108901 | R&S Test Firmware Base=5.14, GSM=5.14 WCDMA=5.14 (current Testsoftw.,f. all band to be used, |
| 489 | EMI Test Receiver | ESU40 | 1000-30 | Firmware=4.43 SP3, Bios=V5.1-16-3, Spec. =01.00 |
| 491 | ESD Simulator dito | ESD dito | dito307022 | V 2.30 |
| 524 | Voltage Drop Simulator | VDS 200 | 0196-16 | Software Nr: 000037 Version V4.20a01 |
| 526 | Burst Generator | EFT 200 A | 0496-06 | Software Nr. 000034 Version V2.32 |
| 527 | Micro Pulse Generator | MPG 200 B | 0496-05 | Software-Nr. 000030 Version V2.43 |
| 528 | Load Dump Simulator | LD 200B | 0496-06 | Software-Nr. 000031 Version V2.35a01 |
| 546 | Univ. Radio Communication Tester | CMU 200 | 106436 | R&S Test Firmware Base=5.14, GSM=5.14 WCDMA=5.14 (current Testsoftw.,f. all band to be used |
| 547 | Univ. Radio Communication Tester | CMU 200 | 835390/014 | R&S Test Firmware Base=V5.1403 (current Testsoftw., f. all band used, GSM = 5.14 WCDMA: = 5.14 |
| 584 | Spectrum Analyzer | FSU 8 | 100248 | 2.82_SP3 |
| 597 | Univ. Radio Communication Tester | CMU 200 | 100347 | R&S Test Firmware Base=5.01, GSM=5.02 WCDMA= not installed, Mainboard= µP1=V.850 |
| 598 | Spectrum Analyzer | FSEM 30 | 831259/013 | Firmware Bios 3.40 , Analyzer 3.40 Sp 2 |
| 607 | Signal Generator | SMR 20 | 832033/011 | V1.25 |
| 620 | EMI Test Receiver | ESU 26 | 100362 | 4.43_SP3 |
| 642 | Wideband Radio Communication Tester | CMW 500 | 126089 | Setup V03.26, Test programm component V03.02.20 |
| 670 | Univ. Radio Communication Tester | CMU 200 | 106833 | µP1 =V8.50, Firmware = V.20 |
| 689 | Vector Signal Generator | SMU200 | 100970 | 02.20.360.142 |
| 692 | Bluetooth Tester | CBT 32 | 100236 | CBT V 5.40, FW: V.2.41 (FPGA Digital, V. 3.09 FPGA RF) |

8.1.2. Single instruments and test systems

| Ref.-No. | Equipment | Type | Serial-No. | Manufacturer | Interval of calibration | Remark | Cal due |
|----------|---|------------------------------|----------------------------|----------------------------|-------------------------|--------|------------|
| 001 | EMI Test Receiver | ESS | 825132/017 | Rohde & Schwarz | 12 M | - | 16.05.2018 |
| 005 | AC - LISN (50 Ohm/50µH, test site 1) | ESH2-Z5 | 861741/005 | Rohde & Schwarz | 12 M | - | 15.05.2018 |
| 007 | Single-Line V-Network (50 Ohm/5µH) | ESH3-Z6 | 892563/002 | Rohde & Schwarz | 12 M | - | 17.05.2018 |
| 009 | Power Meter (EMS-radiated) | NRV | 863056/017 | Rohde & Schwarz | 24 M | - | 15.05.2019 |
| 016 | Line Impedance Simulating Network | Op. 24-D | B6366 | Spitzenberger+Spies | 36 M | - | 30.05.2019 |
| 020 | Horn Antenna 18 GHz (Subst 1) | 3115 | 9107-3699 | EMCO | 36/12 M | - | 31.07.2017 |
| 021 | Loop Antenna (H-Field) | 6502 | 9206-2770 | EMCO | 36 M | - | 30.04.2018 |
| 030 | Loop Antenna (H-field) | HFH-Z2 | 879604/026 | Rohde & Schwarz | 36 M | - | 30.04.2018 |
| 033 | RF-current probe (100kHz-30MHz) | ESH2-Z1 | 879581/18 | Rohde & Schwarz | 24 M | - | 15.05.2019 |
| 057 | relay-switch-unit (EMS system) | RSU | 494440/002 | Rohde & Schwarz | pre-m | 1a | |
| 060 | power amplifier (DC-2kHz) | PAS 5000 | B6363 | Spitzenberger+Spies | - | 3 | |
| 066 | notch filter (WCDMA; FDD1) | WRCT 1900/2200-5/40-10EEK | 5 | Wainwright GmbH | 12 M | 1g | 30.06.2017 |
| 086 | DC - power supply, 0 -10 A | LNG 50-10 | - | Heinzinger Electronic | pre-m | 2 | |
| 087 | DC - power supply, 0 -5 A | EA-3013 S | - | Elektro Automatik | pre-m | 2 | |
| 091 | USB-LWL-Converter | OLS-1 | 007/2006 | Ing. Büro Scheiba | - | 4 | |
| 099 | passive voltage probe | ESH2-Z3 | 299.7810.52 | Rohde & Schwarz | 36 M | - | 30.04.2018 |
| 100 | passive voltage probe | Probe TK 9416 | without | Schwarzbeck | 36 M | - | 30.04.2018 |
| 110 | USB-LWL-Converter | OLS-1 | - | Ing. Büro Scheiba | - | 4 | |
| 119 | RT Harmonics Analyzer dig. Flickermeter | B10 | G60547 | BOCONSULT | 36 M | - | 30.05.2019 |
| 133 | horn antenna 18 GHz (Meas 1) | 3115 | 9012-3629 | EMCO | 36 M | 1c | 10.03.2020 |
| 134 | horn antenna 18 GHz (Subst 2) | 3115 | 9005-3414 | EMCO | 36 M | - | 10.03.2020 |
| 136 | adjustable dipole antenna (Dipole 1) | 3121C-DB4 | 9105-0697 | EMCO | 36 M | - | 30.04.2018 |
| 140 | Signal Generator | SMHU | 831314/006 | Rohde & Schwarz | 24 M | - | 30.05.2018 |
| 248 | attenuator | SMA 6dB 2W | - | Radiall | pre-m | 2 | |
| 249 | attenuator | SMA 10dB 10W | - | Radiall | pre-m | 2 | |
| 252 | attenuator | N 6dB 12W | - | Radiall | pre-m | 2 | |
| 256 | attenuator | SMA 3dB 2W | - | Radiall | pre-m | 2 | |
| 257 | hybrid | 4031C | 04491 | Narda | pre-m | 2 | |
| 260 | hybrid coupler | 4032C | 11342 | Narda | pre-m | 2 | |
| 261 | Thermal Power Sensor | NRV-Z55 | 825083/0008 | Rohde & Schwarz | 24 M | - | 30.05.2018 |
| 262 | Power Meter | NRV-S | 825770/0010 | Rohde & Schwarz | 24 M | - | 30.05.2018 |
| 263 | Signal Generator | SMP 04 | 826190/0007 | Rohde & Schwarz | 36 M | - | 30.05.2019 |
| 265 | peak power sensor | NRV-Z33, Model 04 | 840414/009 | Rohde & Schwarz | 24 M | - | 30.05.2018 |
| 266 | Peak Power Sensor | NRV-Z31, Model 04 | 843383/016 | Rohde & Schwarz | 24 M | - | 30.05.2018 |
| 267 | notch filter GSM 850 | WRCA 800/960-6EEK | 9 | Wainwright GmbH | pre-m | 2 | |
| 270 | termination | 1418 N | BB6935 | Weinschel | pre-m | 2 | |
| 271 | termination | 1418 N | BE6384 | Weinschel | pre-m | 2 | |
| 272 | attenuator (20 dB) 50 W | Model 47 | BF6239 | Weinschel | pre-m | 2 | |
| 273 | attenuator (10 dB) 100 W | Model 48 | BF9229 | Weinschel | pre-m | 2 | |
| 274 | attenuator (10 dB) 50 W | Model 47 (10 dB) 50 W | BG0321 | Weinschel | pre-m | 2 | |
| 275 | DC-Block | Model 7003 (N) | C5129 | Weinschel | pre-m | 2 | |
| 276 | DC-Block | Model 7006 (SMA) | C7061 | Weinschel | pre-m | 2 | |
| 279 | power divider | 1515 (SMA) | LH855 | Weinschel | pre-m | 2 | |
| 287 | pre-amplifier 25MHz - 4GHz | AMF-2D-100M4G-35-10P | 379418 | Miteq | 12 M | 1c | 30.06.2017 |
| 291 | high pass filter GSM 850/900 | WHJ 2200-4EE | 14 | Wainwright GmbH | 12 M | 1c | 30.06.2017 |
| 298 | Univ. Radio Communication Tester | CMU 200 | 832221/091 | Rohde & Schwarz | pre-m | 3 | |
| 300 | AC LISN (50 Ohm/50µH, 1-phase) | ESH3-Z5 | 892 239/020 | Rohde & Schwarz | 12 M | - | 17.05.2018 |
| 301 | attenuator (20 dB) 50W, 18GHz | 47-20-33 | AW0272 | Lucas Weinschel | pre-m | 2 | |
| 302 | horn antenna 40 GHz (Meas 1) | BBHA9170 | 155 | Schwarzbeck | 36 M | - | 14.03.2020 |
| 303 | horn antenna 40 GHz (Subst 1) | BBHA9170 | 156 | Schwarzbeck | 36 M | - | 20.03.2020 |
| 331 | Climatic Test Chamber -40/+180 Grad | HC 4055 | 43146 | Heraeus Vötsch | 24 M | - | 30.10.2018 |
| 341 | Digital Multimeter | Fluke 112 | 81650455 | Fluke | 24 M | - | 30.05.2018 |
| 342 | Digital Multimeter | Voltcraft M-4660A | IB 255466 | Voltcraft | 24 M | - | 17.05.2019 |
| 347 | laboratory site | radio lab. | - | - | - | 5 | |
| 348 | laboratory site | EMI conducted | - | - | - | 5 | |
| 354 | DC - Power Supply 40A | NGPE 40/40 | 448 | Rohde & Schwarz | pre-m | 2 | |
| 355 | Power Meter | URV 5 | 891310/027 | Rohde & Schwarz | 24 M | - | 30.05.2018 |
| 357 | power sensor | NRV-Z1 | 861761/002 | Rohde & Schwarz | 24 M | - | 24.05.2019 |
| 371 | Bluetooth Tester | CBT32 | 100153 | R&S | 36 M | - | 30.05.2019 |
| 373 | Single-Line V-Network (50 Ohm/5µH) | ESH3-Z6 | 100535 | Rohde & Schwarz | 12 M | - | 17.05.2018 |
| 377 | EMI Test Receiver | ESCS 30 | 100160 | Rohde & Schwarz | 12 M | - | 15.05.2018 |
| 389 | Digital Multimeter | Keithley 2000 | 0583926 | Keithley | 24 M | - | 30.04.2017 |
| 392 | Radio Communication Tester | MT8820A | 6K00000788 | Anritsu | 12 M | - | 18.05.2018 |
| 405 | Thermo-/Hygrometer | OPUS 10 THI | 126.0604.0003.3.3.3.2 2 | LUFFT Mess u. Regeltechnik | 24 M | - | 30.03.2019 |
| 431 | Model 7405 | Near-Field Probe Set | 9305-2457 | EMCO | - | 4 | |
| 436 | Univ. Radio Communication Tester | CMU 200 | 103083 | Rohde & Schwarz | 12 M | - | 24.05.2018 |
| 439 | UltraLog-Antenna | HL 562 | 100248 | Rohde & Schwarz | 36 M | - | 10.03.2020 |
| 441 | CTC-SAR-EMI Cable Loss | System EMI field (SAR) Cable | - | CETECOM | 12 M | 5 | 05.06.2017 |
| 443 | CTC-FAR-EMI-RSE | System CTC-FAR-EMI- | - | ETS-Lindgren / | 12 M | 5 | 30.06.2017 |

| Ref.-No. | Equipment | Type | Serial-No. | Manufacturer | Interval of calibration | Remark | Cal due |
|----------|---|-----------------------------|----------------------------|-----------------------------|-------------------------|--------|------------|
| | | RSE | | CETECOM | | | |
| 448 | notch filter WCDMA_FDD II | WRCT 1850.0/2170.0-5/40- | 5 | Wainwright Instruments GmbH | 12 M | 1c | 30.06.2017 |
| 449 | notch filter WCDMA FDD V | WRCT 824.0/894.0-5/40-8SSK | 1 | Wainwright | 12 M | 1c | 30.06.2017 |
| 454 | Oscilloscope | HM 205-3 | 9210 P 29661 | Hameg | - | 4 | |
| 456 | DC-Power supply 0-5 A | EA 3013 S | 207810 | Elektro Automatik | pre-m | 2 | |
| 459 | DC -Power supply 0-5 A , 0-32 V | EA-PS 2032-50 | 910722 | Elektro Automatik | pre-m | 2 | |
| 460 | Univ. Radio Communication Tester | CMU 200 | 108901 | Rohde & Schwarz | 12 M | - | 16.06.2018 |
| 463 | Universal source | HP3245A | 2831A03472 | Agilent | - | 4 | |
| 466 | Digital Multimeter | Fluke 112 | 89210157 | Fluke USA | 24 M | - | 30.05.2018 |
| 467 | Digital Multimeter | Fluke 112 | 89680306 | Fluke USA | 36 M | - | 30.04.2018 |
| 468 | Digital Multimeter | Fluke 112 | 90090455 | Fluke USA | 36 M | - | 30.04.2018 |
| 477 | ReRadiating GPS-System | AS-47 | - | Automotive Cons. Fink | - | 3 | |
| 480 | power meter (Fula) | NRVS | 838392/031 | Rohde & Schwarz | 24 M | - | 16.05.2019 |
| 482 | filter matrix | Filter matrix SAR 1 | - | CETECOM (Brl) | - | 1d | |
| 484 | pre-amplifier 2,5 - 18 GHz | AMF-5D-02501800-25-10P | 1244554 | Miteq | 12 M | - | 30.07.2017 |
| 487 | System CTC NSA-Verification SAR-EMI | System EMI field (SAR) NSA | - | ETS Lindgren / CETECOM | 24 M | - | 31.07.2017 |
| 489 | EMI Test Receiver | ESU40 | 1000-30 | Rohde & Schwarz | 12 M | - | 18.05.2019 |
| 502 | band reject filter | WRCG 1709/1786-1699/1796- | SN 9 | Wainwright | pre-m | 2 | |
| 503 | band reject filter | WRCG 824/849-814/859- | SN 5 | Wainwright | pre-m | 2 | |
| 512 | notch filter GSM 850 | WRCA 800/960-02/40-6EEK | SN 24 | Wainwright | 12 M | 1c | 30.06.2017 |
| 517 | relais switch matrix | HF Relais Box Keithley | SE 04 | Keithley | pre-m | 2 | |
| 523 | Digital Multimeter | L4411A | MY46000154 | Agilent | 24 M | - | 18.05.2019 |
| 529 | 6 dB Broadband resistive power divider | Model 1515 | LH 855 | Weinschel | pre-m | 2 | |
| 530 | 10 dB Broadband resistive power divider | R 416110000 | LOT 9828 | - | pre-m | 2 | |
| 546 | Univ. Radio Communication Tester | CMU 200 | 106436 | R&S | 12 M | - | 30.03.2018 |
| 547 | Univ. Radio Communication Tester | CMU 200 | 835390/014 | Rohde & Schwarz | 12 M | - | 30.04.2017 |
| 549 | Log.Per-Antenna | HL025 | 1000060 | Rohde & Schwarz | 36/12 M | - | 31.07.2018 |
| 550 | System CTC S-VSWR Verification SAR-EMI | System EMI Field SAR S-VSWR | - | ETS Lindgren/CETECOM | 24 M | - | 31.07.2017 |
| 552 | high pass filter 2.8-18GHz | WHKX 2.8/18G-10SS | 4 | Wainwright | 12 M | 1c | 30.06.2017 |
| 557 | System CTC-OTA-2 | R&S TS8991 | - | Rohde & Schwarz | 12 M | 5 | 30.09.2016 |
| 558 | System CTC FAR S-VSWR | System CTC FAR S-VSWR | - | CTC | 24 M | - | 31.07.2017 |
| 574 | Biconilog Hybrid Antenna | BTA-L | 980026L | Frankonia | 36/12 M | - | 31.03.2019 |
| 584 | Spectrum Analyzer | FSU 8 | 100248 | Rohde & Schwarz | pre-m | - | |
| 594 | Wideband Radio Communication Tester | CMW 500 | 101757 | Rohde & Schwarz | 12 M | - | 30.04.2017 |
| 597 | Univ. Radio Communication Tester | CMU 200 | 100347 | Rohde & Schwarz | pre-m | - | |
| 598 | Spectrum Analyzer | FSEM 30 | 831259/013 | Rohde & Schwarz | 24 M | - | 30.04.2017 |
| 600 | power meter | NRVD (Reserve) | 834501/018 | Rohde & Schwarz | 24 M | - | 17.05.2019 |
| 601 | medium-sensitivity diode sensor | NRV-Z5 (Reserve) | 8435323/003 | Rohde & Schwarz | 24 M | - | 15.05.2019 |
| 602 | peak power sensor | NRV-Z32 (Reserve) | 835080 | Rohde & Schwarz | 24 M | - | |
| 608 | UltraLog-Antenna | HL 562 | 830547/009 | Rohde & Schwarz | 36 M | - | 31.03.2014 |
| 611 | DC power supply | E3632A | KR 75305854 | Agilent | pre-m | 2 | |
| 612 | DC power supply | E3632A | MY 40001321 | Agilent | pre-m | 2 | |
| 613 | Attenuator | R416120000 20dB 10W | Lot. 9828 | Radiall | pre-m | 2 | |
| 616 | Digitalmultimeter | Fluke 177 | 88900339 | Fluke | 24 M | - | 30.05.2018 |
| 617 | Power Splitter/Combiner | ZFSC-2-2-S+ | S F987001108 | Mini Circuits | - | 2 | |
| 618 | Power Splitter/Combiner | 50PD-634 | 600994 | JFW Industries USA | - | 2 | |
| 619 | Power Splitter/Combiner | 50PD-634 | 600995 | JFW Industries, USA | - | 3 | |
| 620 | EMI Test Receiver | ESU 26 | 100362 | Rohde-Schwarz | 12 M | - | 16.05.2018 |
| 621 | Step Attenuator 0-139 dB | RSP | 100017 | Rohde & Schwarz | pre-m | 2 | |
| 625 | Generic Test Load USB | Generic Test Load USB | - | CETECOM | - | 2 | |
| 627 | data logger | OPUS 1 | 201.0999.9302.6.4.1.4 3 | G. Lufft GmbH | 24 M | - | 30.03.2019 |
| 634 | Spectrum Analyzer | FSM (HF-Unit) | 826188/010 | Rohde & Schwarz | pre-m | 2 | |
| 637 | High Speed HDMI with Ethernet 1m | HDMI cable with Ethernet 1m | - | KogiLink | - | 2 | |
| 638 | HDMI Kabel with Ethernet 1,5 m flach | HDMI cable with Ethernet | - | Reichelt | - | 2 | |
| 640 | HDMI cable 2m rund | HDMI cable 2m rund | - | Reichelt | - | 2 | |
| 641 | HDMI cable with Ethernet | Certified HDMI cable with | - | PureLink | - | 2 | |
| 642 | Wideband Radio Communication Tester | CMW 500 | 126089 | Rohde&Schwarz | 12 M | - | 24.05.2018 |
| 644 | Amplifierer | ZX60-2534M+ | SN865701299 | Mini-Circuits | - | - | |
| 670 | Univ. Radio Communication Tester | CMU 200 | 106833 | Rohde & Schwarz | 24 M | - | 30.05.2018 |
| 671 | DC-power supply 0-5 A | EA-3013S | - | Elektro Automatik | pre-m | 2 | |
| 678 | Power Meter | NRP | 101638 | Rohde&Schwarz | pre-m | - | |
| 683 | Spectrum Analyzer | FSU 26 | 200571 | Rohde & Schwarz | 12 M | - | 17.05.2018 |
| 686 | Field Analyzer | EHP-200A | 160WX30702 | Narda Safety Test Solutions | 24 M | - | 29.03.2019 |
| 687 | Signal Generator | SMF 100A | 102073 | Rohde&Schwarz | 12 M | - | 17.05.2018 |

| Ref.-No. | Equipment | Type | Serial-No. | Manufacturer | Interval of calibration | Remark | Cal due |
|----------|-----------------------------------|-------------------------|------------------------|------------------------|-------------------------|--------|------------|
| 688 | Pre Amp | JS-18004000-40-8P | 1750117 | Miteq | pre-m | - | |
| 690 | Spectrum Analyzer | FSU | 100302/026 | Rohde&Schwarz | 12 M | - | 16.05.2018 |
| 691 | OSP120 Base Unit | OSP120 | 101183 | Rohde & Schwarz | 12 M | - | 22.05.2018 |
| 692 | Bluetooth Tester | CBT 32 | 100236 | Rohde & Schwarz | 36 M | - | 29.05.2020 |
| 693 | TS8997 | CTC-Radio Lab 1_TS8997 | - | Rohde&Schwarz | 12 M | 5 | 06.06.2017 |
| 697 | Power Splitter | ZN4PD-642W-S+ | 165001445 | Mini-Circuits | - | 2 | |
| 701 | CMW500 wide. Radio Comm. | CMW500 | 158150 | Rohde & Schwarz | 12 M | - | 01.05.2017 |
| 703 | INNCO Antennen Mast | MA 4010-KT080-XPET-ZSS3 | MA4170-KT100-XPET- | INNCO | pre-m | - | |
| 704 | INNCON Controller | CO 3000-4port | CO3000/933/3841051 6/L | INNCO Systems GmBh | pre-m | - | |
| 711 | Harmonic Mixer 90 GHz - 140GHz | RPG FS-Z140 | 101004 | RPG | 12 M | - | 22.02.2018 |
| 712 | Harmonic Mixer 75 GHz - 110GHz | FS-Z110 | 101468 | Rohde & Schwarz | 12 M | - | 22.02.2018 |
| 713 | Harmonic Mixer, 50 GHz - 75GHz | FS-Z75 | 101022 | Rohde & Schwarz | 12 M | - | 22.05.2018 |
| 714 | Signal Analyzer 67GHz | FSW67 | 104023 | Rohde & Schwarz | 24 M | - | 03.03.2019 |
| 715 | Harmonic Mixer, 140 GHz - 220GHz | FS-Z220 | 101009 | RPG Radiometer Physics | 12 M | - | 03.08.2018 |
| 716 | Harmonic Mixer 220 GHz to 325 GHZ | FS-Z325 | 101005 | RPG Radiometer Physics | 12 M | - | 13.02.2018 |
| 747 | Spectrum Analyzer | FSU 26 | 200152 | Rohde & Schwarz | 12 M | - | 18.05.2018 |
| 748 | Pickett-Potter Horn Antenna | FH-PP 4060 | 010001 | Radiometer Physics | - | - | |
| 749 | Pickett-potter Horn Antenna | FH-PP 60-90 | 010003 | Radiometer Physics | - | - | |
| 750 | Pickett-Potter Horn Antenna | FH-PP 140-220 | 010011 | Radiometer Physics | - | - | |

8.1.3. Legend

| Note / remarks | Calibrated during system calibration: |
|----------------|---|
| 1a | System CTC-SAR-EMS (Ref.-No. 442) |
| 1b | System-CTC-EMS-Conducted (Ref.-No. 335) |
| 1c | System CTC-FAR-EMI-RSE (Ref.-No . 443) |
| 1d | System CTC-SAR-EMI (Ref.-No . 441) |
| 1e | System CTC-OATS (EMI radiated) (Ref.-No. 337) |
| 1 f | System CTC-CTIA-OTA (Ref.-No . 420) |
| 1 g | System CTC-FAR-EMS (Ref.-No . 444) |
| 2 | Calibration or equipment check immediately before measurement |
| 3 | Regulatory maintained equipment for functional check or support purpose |
| 4 | Ancillary equipment without calibration e.g. mechanical equipment or monitoring equipment |
| 5 | Test System |

| | | |
|-------------------------|---------|---|
| Interval of calibration | 12 M | 12 month |
| | 24 M | 24 month |
| | 36 M | 36 month |
| | 24/12 M | Calibration every 24 months. between this every 12 months internal validation |
| | 36/12 M | Calibration every 36 months. between this every 12 months internal validation |
| | Pre-m | Check before starting the measurement |
| | - | Without calibration |

9. Versions of test reports (change history)

| Version | Applied changes | Date of release |
|---------|-----------------|-----------------|
| -- | Initial release | 2017-07-10 |
| -- | -- | -- |
| -- | -- | -- |