

TEST REPORT
No.: 18-1-0048401T01a

According to:

FCC Regulations

Part 15.205
Part 15.209
Part 15.407

ISED-Regulations

RSS-Gen, Issue 4
RSS-247, Issue 2

for

Robert Bosch Car Multimedia

Navigation System with Bluetooth and WLAN
AIVIL12F0

FCC ID: YBN-AIVIL12F0

ISED: 9595A-AIVIL12F0







Laboratory Accreditation and Listings		
 <small>Deutsche Akkreditierungsstelle D-PL-12047-01-01</small> Accredited EMC-Test Laboratory	 Industry Canada Reg. No.: 3462D-1 Reg. No.: 3462D-2 Reg. No.: 3462D-3	 Voluntary Controls for Electromagnetic Emissions Reg. No.: R-20013, C-20009, T-20006, G-20013
 <small>AUTHORIZED RF LABORATORY</small>	 <small>Authorized™ Test Lab Lab Code: 20011130-00</small>	 <small>FEDERAL COMMUNICATIONS COMMISSION U.S.A. MRA US-EU 0003</small>
accredited according to DIN EN ISO/IEC 17025		
CETECOM GmbH Laboratory Radio Communications & Electromagnetic Compatibility Im Teelbruch 116 • 45219 Essen • Germany Registered in Essen, Germany, Reg. No.: HRB Essen 8984 Tel.: + 49 (0) 20 54 / 95 19-954 • Fax: + 49 (0) 20 54 / 95 19-964 E-mail: info@cetecom.com • Internet: www.cetecom.com		
Laboratory Accreditation and Listings		

Table of Contents

1. SUMMARY OF TEST RESULTS.....	3
1.1. Tests measurement overview according to US CFR Title 47, Subpart 15C	3
1.2. Attestation:.....	6
2. ADMINISTRATIVE DATA	7
2.1. Identification of the testing laboratory	7
2.2. Test location	7
2.3. Organizational items	7
2.4. Applicant’s details	7
2.5. Manufacturer’s details	7
3. EQUIPMENT UNDER TEST (EUT).....	8
3.1. Certification Data of Main EUT declared by Applicant	8
3.2. WLAN 5 GHz 802.11a/n Technical Data Of Main EUT as Declared by Applicant	9
3.3. EUT: Type, S/N etc. and short descriptions used in this test report	10
3.4. Auxiliary Equipment (AE): Type, S/N etc. and short descriptions	10
3.5. EUT set-ups	10
3.6. EUT operating modes	10
3.7. Worst case identification	12
4. DESCRIPTION OF TEST SYSTEM SET-UP’S	13
4.1. Test system set-up for conducted measurements on antenna port	13
4.2. Test system set-up for radiated magnetic field measurements below 30 MHz.....	15
4.3. Test system set-up for radiated electric field measurement 30 MHz to 1 GHz	16
4.4. Test system set-up for radiated electric field measurement above 1 GHz.....	17
5. MEASUREMENTS	18
5.1. General Limit – Maximum power output conducted	18
5.2. General Limit - Radiated field strength emissions below 30 MHz.....	21
5.3. General Limit - Radiated field strength emissions, 30 MHz - 1 GHz.....	23
5.4. General Limit - Radiated emissions, above 1 GHz.....	25
5.5. RF-Parameter - Radiated Band-Edge compliance measurements.....	27
5.6. Measurement uncertainties	30
6. ABBREVIATIONS USED IN THIS REPORT	31
7. ACCREDITATION DETAILS OF CETECOM’S LABORATORIES AND TEST SITES	31
8. INSTRUMENTS AND ANCILLARY.....	32
8.1. Used equipment “CTC”	32
9. VERSIONS OF TEST REPORTS (CHANGE HISTORY)	35

Table of annex

	Total pages
Annex 1: Test result diagrams (separate document) CETECOM-TR18-1-0048401T01a-A1	52
Annex 2: External photographs of EUT (separate document) CETECOM- TR18-1-0048401T01a-A2	4
Annex 3: Please refer to external document “AIVIL12F0_Internal_Pictures” dated 2018-06-04	9
Annex 4: Test set-up photographs (separate document) CETECOM- TR18-1-0048401T01a -A4	5

1. Summary of test results

The test results apply exclusively to the test samples as presented in this report. The CETECOM GmbH does not assume responsibility for any conclusions and generalizations taken in conjunction with other specimens or samples of the type of the item presented to tests. Also we refer on special conditions which the applicant should fulfill according §2.927 to §2.948, special focus regarding modification of the equipment and availability of sample equipment for market surveillance tests.

The presented Equipment Under Test (in this report, hereinafter referred as EUT) supports radiofrequency technologies with WLAN technology and operating frequency range at 5.150 to 5.850 GHz according to IEE 802.11 a. The EUT is a variant of **AIVIL42P0 (FCC ID: YBNAIVIL42P0 and ISED: 9595A-AIVIL42P0)**. Due no modifications on the WLAN Part of the module only radiated tests have been performed. In addition power verification tests have been performed too. Other implemented wireless technologies were not considered within this test report.

Following test cases have been performed to show compliance with valid Part 15.407/15.209 of the FCC CFR Title 47 Rules, Edition 2017 and ISED RSS-247 Issue 2/RSS-Gen Issue 4 standards.

1.1. Tests measurement overview according to US CFR Title 47, Subpart 15C

Test cases	Port	References and Limits			EUT set-up	EUT op. mode	Result
		FCC Standard	RSS Standard	Test limit			
TX-Mode							
99% occupied bandwidth	Antenna terminal (conducted)	2.1049(h)	RSS-Gen, Issue 4 Chapter 6.6	99% Power bandwidth	--	--	Remark 1)
26 dB bandwidth	Antenna terminal (conducted)	§15.303 + §15.407(a) (2) (5)	RSS-Gen, Issue 4 Chapter 6.6	26 dB spectral density bandwidth	--	--	Remark 1)
Duty-Cycle	Antenna terminal (conducted)	KDB789033 + ANSI C63.10:2013	KDB789033 + ANSI C63.10:2013	No Limit Criteria	1	1 2	Performed

Maximum output power	Antenna terminal (conducted)	<p>§15.407(a)</p> <p>(1)(iv) 5.15-5.25 GHz Client devices</p> <p>(2) 5.25-5.35 GHz & 5.47-5.725 GHz</p> <p>(3) 5.725-5.85 GHz</p>	<p>RSS-247, Issue 2 Chapter</p> <p>6.2.1.1</p> <p>6.2.2.1</p> <p>6.2.3.1 6.2.4.1</p>	<p>Power Limits (if Antenna Gain < 6 dBi)</p> <p>250 mW</p> <p>lesser of 250mW or 11dBm+10logB</p> <p>1 W</p>	2	1 2	Pass Remark 3)
Peak Power Spectral density	Antenna terminal (conducted)	<p>§15.407(a)</p> <p>(1)(iv) 5.15-5.25 GHz Client devices</p> <p>(2) 5.25-5.35 GHz & 5.47-5.725 GHz</p> <p>(3) 5.725-5.85 GHz</p>	<p>RSS-247, Issue 2 Chapter</p> <p>6.2.1.1</p> <p>6.2.2.1</p> <p>6.2.3.1 6.2.4.1</p>	<p>Power Spectral Density Limits (if Antenna Gain < 6 dBi)</p> <p>11dBm/MHz</p> <p>11dBm/MHz</p> <p>30dBm/500kHz</p>	--	--	Remark 1)
Maximum e.i.r.p. power	Antenna terminal (conducted) + Antenna Gain	<p>§15.407(a)</p> <p>(1)(iv) 5.15-5.25 GHz Client devices</p> <p>(2) 5.25-5.35 GHz & 5.47-5.725 GHz</p> <p>(3) 5.725-5.85 GHz</p>	<p>RSS-247, Issue 2 Chapter</p> <p>6.2.1.1</p> <p>6.2.2.1</p> <p>6.2.3.1 6.2.4.1</p>	<p>e.i.r.p. Limits (if Antenna Gain < 6 dBi)</p> <p>250 mW + 6 dBi</p> <p>lesser of 250mW or 11dBm+10logB + 6 dBi</p> <p>1 W + 6 dBi</p>	2	1 2	Pass Remark 3) (calculated)
Antenna gain information	Antenna terminal (conducted)	<p>§15.407(a) (1)(2)(3)</p>	<p>RSS-247, Issue 2 chapter 6.2.1.1 6.2.2.1 6.2.3.1 6.2.4.1</p>	<p>< 6dBi or if Antenna directional Gain > 6dBi reduction of Max. power & power spectral density by the amount in dB that the directional gain of the antenna exceeds 6 dBi</p>	--	--	Separate test report TR18- 1- 0048401T07a 3.5dBi max.

<p>General field strength emissions within restricted bands</p> <p>+</p> <p>Band-Edge compliance radiated</p>	<p>Enclosure + Inter-connecting cables (radiated)</p>	<p>§15.407(b) (1)(2)(3)(4)(5)(6) (7)(8)</p> <p>§15.205 + §15.209</p>	<p>RSS-Gen., Issue 4 + RSS-247, Issue 2 Chapter 6.2.1.2 , 6.2.2.2 6.2.3.2, + 6.2.4.2</p> <p>RSS-Gen., Issue 4 + RSS-247, Issue 2 Chapter 6.2.1.2 , 6.2.2.2 6.2.3.2, + 6.2.4.2</p>	<p>5150-5250 MHz 5250-5350 MHz 5470-5725 MHz all emissions outside operating band shall not exceed -27 dBm/MHz e.i.r.p.</p> <p>5725-5850 MHz Spectrum Mask acc. to (4)(i)</p> <p>Restricted band limits + General field strength limits</p>	<p>1</p>	<p>1 2</p>	<p>Pass Remark 3)</p>
<p>Transmit power control + Dynamic frequency selection (DFS)</p>	<p>Antenna terminal (conducted)</p>	<p>§15.407 (h1)(h2)</p>	<p>RSS-Gen., Issue 4 + RSS-247, Issue 2 Chapter 6.3</p>	<p>Requirements: Masters Active clients Passive clients</p>	<p>--</p>	<p>--</p>	<p>Remark 2)</p>
<p>Discontinuous transmissions + Device security</p>	<p>FIRMWARE</p>	<p>§15.407(c) + §15.407(i)</p>	<p>RSS-247, Issue 2 Chapter 6.4 a + b + c</p>	<p>No transmissions in case of either absence of information to transmit or operational failure + Protection of firmware by unauthorized parties</p>	<p>--</p>	<p>--</p>	<p>Not tested Applicants declaration of implementation</p>
<p>AC-Power Lines Conducted Emissions</p>	<p>AC-Power lines or Battery Charger</p>	<p>§15.207(a)</p>	<p>RSS-Gen, Issue 4: Chapter 8.8 Table 3</p>	<p>AC Power line conducted limits</p>	<p>--</p>	<p>--</p>	<p>Not applicable</p>

Remark 1) Please refer to separate FCC RF Test Report BTL-FCCP-3-1807C078_5G with FCC-ID: YBN-AIVIL42P0 and ISED Test Report BTL-ISED-3-1807C078_5G with ISED 9595A-AIVIL42P0

2) Please refer to separate FCC RF Test Report BTL-FCCP-4-1807C078_Slave DFS with FCC-ID: YBN-AIVIL42P0 and ISED Test Report BTL-ISED-4-1807C078_Slave DFS with ISED 9595A-AIVIL42P0

3) only worst case mode was tested from reference FCC-ID YBN-AIVIL42P0. For modulations and data rates not tested within this test report please refer to Test Report BTL-FCCP-3-1807C078_5G with FCC-ID: YBN-AIVIL42P0 and ISED Test Report BTL-ISED-3-1807C078_5G with ISED 9595A-AIVIL42P0

RF-Exposure Evaluation (separation distance user to RF-radiating element greater 20cm)							
Test cases	Port	References & Limits			EUT set-up	EUT Op mode	Result
		FCC Standard	RSS Section	Test Limit			
Radio frequency radiation exposure requirements	Cabinet + Inter-connecting cables (radiated)	§1.1310(b) §2.1091 §2.1093	RSS-102 Issue 5	SAR-Limits FCC: 1.1310(b)	1	1	See separate test reports 18-1-0048401T05a
				RF-Field Strength Limits: FCC: “general population/uncontrolled” environment Table 1 ISED: Table 4	1	1	

1.2. Attestation:

I declare that all measurements were performed by me or under my supervision and that all measurements have been performed and are correct to my best knowledge and belief to Innovation , Science and Economic Development (ISED) Canada standards. All requirements as shown in above table are met in accordance with enumerated standards.



.....
Dipl.-Ing. Rachid Acharkaoui
Responsible for test section



.....
Dipl.-Ing Ninovic Perez
Responsible for test report

2. Administrative Data

2.1. Identification of the testing laboratory

Company name:	CETECOM GmbH
Address:	Im Teelbruch 116 45219 Essen - Kettwig Germany
Responsible for testing laboratory:	Dipl.-Ing. Niels Jeß
Deputy:	Dipl.-Ing. Rachid Acharkaoui

2.2. Test location

2.2.1. Test laboratory "CTC"

Company name:	see chapter 2.1. Identification of the testing laboratory
---------------	---

2.3. Organizational items

Responsible for test report and Project leader:	Dipl.-Ing N. Perez Dipl.-Ing N. Perez
Receipt of EUT:	2018-06-12
Date(s) of test:	2018-06-12 - 2018-07-18
Date of report:	2018-07-20

Version of template:	13.02

2.4. Applicant's details

Applicant's name:	Robert Bosch Car Multimedia
Address:	Robert-Bosch-Str. 200 31139 Hildesheim Germany
Contact :	Mr. Salvatore Miraglia

2.5. Manufacturer's details

Manufacturer's name:	please see applicant's details
Address:	please see applicant's details

3. Equipment under test (EUT)

3.1. Certification Data of Main EUT declared by Applicant

FCC ID	YBN-AIVIL12F0		
IC/ISED	9595A-AIVIL12F0		
Frequency range (US/Canada -bands)	<input checked="" type="checkbox"/> 5150 MHz (Channel 36) to 5250 MHz (Channel 48) for 20MHz BW <input checked="" type="checkbox"/> 5250 MHz (Channel 52) to 5350 MHz (Channel 64) for 40MHz BW <input checked="" type="checkbox"/> 5470 MHz (Channel 100) to 5725 MHz (Channel 140) for 40MHz BW <input checked="" type="checkbox"/> 5725 MHz (Channel 149) to 5850 MHz (Channel 165) for 40MHz BW		
Type of modulation	See chapter 3.2		
Antenna Type	<input checked="" type="checkbox"/> Integrated <input type="checkbox"/> External, no RF- connector <input type="checkbox"/> External, separate RF-connector		
Antenna Gain	3.5dBi max		
Max. Conducted Output Power *1)	RMS		
Power 802.11a	6.25dBm		
Power HT20	7.73dBm		
Power HT40	6.92dBm		
Power HT80	7.49dBm		
EIRP Power (calculated)	EIRP Power (calculated)		
Power 802.11a	6.25dBm +3.5dBi =9.75dBm		
Power HT20	7.73dBm +3.5dBi =11.23dBm		
Power HT40	6.92dBm +3.5dBi =10.42dBm		
Power HT80	7.49dBm +3.5dBi =10.99dBm		
Installed options	<input checked="" type="checkbox"/> 802.11 b/g/n (not tested within this report) <input checked="" type="checkbox"/> Bluetooth (not tested within this report) <input type="checkbox"/> LTE FDD Band 2, 4, 5, 12 (not tested within this report) <input type="checkbox"/> UMTS Band 2, 4, 5 (not tested within this report)		
Power supply	<input type="checkbox"/> Internal battery Li-Io, range 3.5V to 4.1V <input type="checkbox"/> over AC/DC adapter: 110V/60 Hz <input checked="" type="checkbox"/> Nominal Test Voltage : 13.5 VDC with external power supply		
Special EMI components	--		
EUT sample type	<input type="checkbox"/> Production	<input checked="" type="checkbox"/> Pre-Production	<input type="checkbox"/> Engineering
FCC label attached	<input type="checkbox"/> yes	<input checked="" type="checkbox"/> no	

Remark: *1) Power values for HT20, HT40 and HT80 taken from Test Report BTL-FCCP-3-1807C078_5G with FCC-ID: YBN-AIVIL42P0 and ISED Test Report BTL-ISED-3-1807C078_5G with ISED 9595A-AIVIL42P0

3.2. WLAN 5 GHz 802.11a/n Technical Data Of Main EUT as Declared by Applicant

Firmware Version	--		
Frequency Channel B.W. (USA bands only)	U-NII 1: 5150-5250 MHz	<input checked="" type="checkbox"/> Ch 36 40 44 48	<input checked="" type="checkbox"/> Bandwidth 20 MHz
		<input checked="" type="checkbox"/> Ch. 38 46	<input checked="" type="checkbox"/> Bandwidth 40 MHz
		<input checked="" type="checkbox"/> Ch. 42	<input checked="" type="checkbox"/> Bandwidth 80 MHz
	U-NII2A: 5250-5350 MHz	<input checked="" type="checkbox"/> Ch 52 56 60 64	<input checked="" type="checkbox"/> Bandwidth 20 MHz
		<input checked="" type="checkbox"/> Ch. 54 62	<input checked="" type="checkbox"/> Bandwidth 40 MHz
		<input checked="" type="checkbox"/> Ch. 58	<input checked="" type="checkbox"/> Bandwidth 80 MHz
	U-NII 2C: 5470-5725 MHz	<input checked="" type="checkbox"/> Ch 100 104 108	<input checked="" type="checkbox"/> Bandwidth 20 MHz
		<input checked="" type="checkbox"/> Ch 112 116 120	
		<input checked="" type="checkbox"/> Ch 124 128 132	
		<input checked="" type="checkbox"/> Ch 136 140	<input checked="" type="checkbox"/> Bandwidth 40 MHz
		<input checked="" type="checkbox"/> Ch. 102 110 118	
		<input checked="" type="checkbox"/> Ch 126 134	
	U-NII 3: 5725 -5850 MHz	<input checked="" type="checkbox"/> Ch 106 122	<input checked="" type="checkbox"/> Bandwidth 80 MHz
		<input checked="" type="checkbox"/> Ch 149 153 157	<input checked="" type="checkbox"/> Bandwidth 20 MHz
		<input checked="" type="checkbox"/> Ch 161 165	<input checked="" type="checkbox"/> Bandwidth 40 MHz
<input checked="" type="checkbox"/> Ch 151 159		<input checked="" type="checkbox"/> Bandwidth 80 MHz	
Frequency Channel B.W. (Additional U-NII 2C for Canada)	U-NII 2C: 5470-5600 MHz 5650-5725 MHz	<input checked="" type="checkbox"/> Ch 100 104 108	<input checked="" type="checkbox"/> Bandwidth 20 MHz
		<input checked="" type="checkbox"/> Ch 112 116 120	
		<input checked="" type="checkbox"/> Ch 132	
	<input checked="" type="checkbox"/> Ch 136 140	<input checked="" type="checkbox"/> Bandwidth 40 MHz	
	<input checked="" type="checkbox"/> Ch 102 110 118		
	<input checked="" type="checkbox"/> Ch 134		
<input checked="" type="checkbox"/> Ch 106	<input checked="" type="checkbox"/> Bandwidth 80 MHz		
802.11a – Mode OFDM Modulation Data Rates	<input checked="" type="checkbox"/> BPSK 6 Mbps / 9 Mbps <input checked="" type="checkbox"/> QPSK 12 Mbps / 18 Mbps <input checked="" type="checkbox"/> 16-QAM 24 Mbps / 36 Mbps <input checked="" type="checkbox"/> 64-QAM 48 Mbps / 54 Mbps		
802.11n – Mode OFDM Modulation Data Rates	<input checked="" type="checkbox"/> HT20 (MCS0 – MCS7) 7.2/14.4/21.7/28.9/43.3/57.8/65/72.2 Mbps <input checked="" type="checkbox"/> HT40 (MCS0 – MCS7) 15/30/45/60/90/120/135/150 Mbps		
802.11ac – Mode OFDM Modulation Data Rates	<input checked="" type="checkbox"/> HT20 (MCS0 – MCS9) 7.2/14.4/21.7/28.9/43.3/57.8/65/72.2 Mbps <input checked="" type="checkbox"/> HT40 (MCS0 – MCS9) 15/30/45/60/90/120/135/150 Mbps <input checked="" type="checkbox"/> HT80 (MCS0 – MCS9) 7.2/14.4/21.7/28.9/43.3/57.8/65/72.2 Mbps		
Power Supply	<input checked="" type="checkbox"/> Nominal Test Voltage : 13.5 VDC with external power supply		
Special EMI Components	--		
EUT sample type	<input type="checkbox"/> Production	<input checked="" type="checkbox"/> Pre-Production	<input type="checkbox"/> Engineering
FCC label attached	<input type="checkbox"/> yes	<input checked="" type="checkbox"/> no	

3.3. EUT: Type, S/N etc. and short descriptions used in this test report

Short description*)	EUT	Type	S/N serial number	HW hardware status	SW software status
EUT A	AIVIL12F0	Navigation System with Bluetooth and WLAN	0007647	001	X317 (0539)
EUT B	AIVIL12F0	Navigation System with Bluetooth and WLAN	0007625	001	X317 (0539)

*) EUT short description is used to simplify the identification of the EUT in this test report.

3.4. Auxiliary Equipment (AE): Type, S/N etc. and short descriptions

AE short description *)	Auxiliary Equipment	Type	S/N serial number	HW hardware status	SW software status
AE 1	Harness	Test Cable	--	--	--

*) AE short description is used to simplify the identification of the auxiliary equipment in this test report.

3.5. EUT set-ups

EUT set-up no. *)	Combination of EUT and AE	Description
set. 1	EUT A + AE 1	Radiated measurement set-up
set. 2	EUT B + AE 1	Conducted measurement set-up

*) EUT set-up no. is used to simplify the identification of the EUT set-up in this test report.

3.6. EUT operating modes

EUT operating mode no. *)	Description of operating modes	Additional information
op. 1	TX-Mode Burst 20MHz	With help of special test firmware WLAN is switched to a bandwidth of 20MHz and a continuous traffic mode in burst mode (duty cycle >98%) was set-up *)
op. 2	TX-Mode Burst 40MHz	With help of special test firmware WLAN is switched to a bandwidth of 40MHz and a continuous traffic mode in burst mode (duty cycle >98%) was set-up *)
op. 3	TX-Mode Burst 80MHz	With help of special test firmware WLAN is switched to a bandwidth of 80MHz and a continuous traffic mode in burst mode (duty cycle >98%) was set-up *)

*) EUT operating mode no. is used to simplify the test report.

*) Please refer to document "Instructions_RadioTypeApproval_9_6_2017" dated 2017-06-09 for additional information regarding operating mode setup and output power levels.

The following settings have been done under SW Labtool:

Make the main settings which only have to be set once (per session):

30 0 (Choose the 2,4G band) or 30 1 (Choose the 5G band)

112 0 (20 MHz Bandwidth) or 112 1 (40 MHz Bandwidth) or 112 4 (80 MHz Bandwidth)

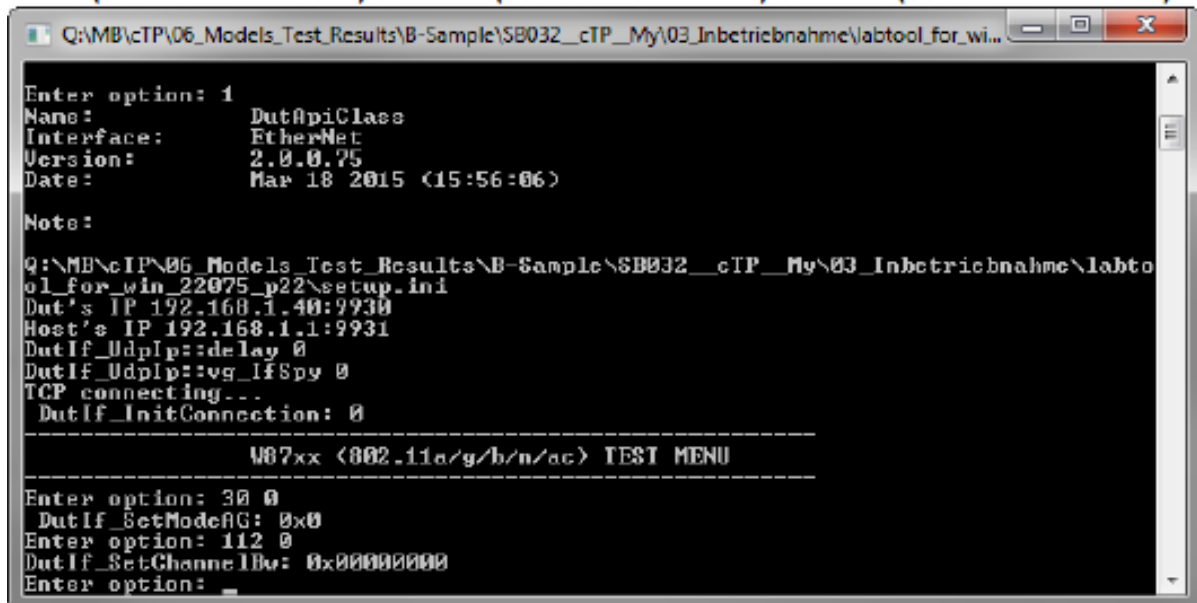

```
Q:\MB\cTP\06_Models_Test_Results\B-Sample\SB032_cTP_My\03_Inbetriebnahme\labtool_for_wi...
Enter option: 1
Name:          DutApiClass
Interface:     EtherNet
Version:       2.0.0.75
Date:         Mar 18 2015 (15:56:06)

Note:
Q:\MB\cIP\06_Models_Test_Results\B-Sample\SB032_cTP_My\03_Inbetriebnahme\labto
ol_for_win_22075_p22\setup.ini
Dut's IP 192.168.1.40:9930
Host's IP 192.168.1.1:9931
DutIf_UdpIp::delay 0
DutIf_UdpIp::vg_ifSpy 0
TCP connecting...
DutIf_InitConnection: 0

-----
W07xx (802.11a/g/b/n/ac) TEST MENU
-----
Enter option: 30 0
DutIf_SetModeAG: 0x0
Enter option: 112 0
DutIf_SetChannelBw: 0x00000000
Enter option: _
```

Now the parameters for **Channel**, **Power level** and **modulation group** has to be done:

22 1 14 0



```
Enter option: 22 1 14 0
DutIf_SetRfChannel: 0x0
DutIf_SetRfPowerCal: 0x0
Enter option:
```

For 802.11b the Power level is always 14 and the modulation group is 0

For 802.11g the Power level is always 11 and the modulation group is 1

For 802.11n (2,4GHz) the Power level is always 11 and the modulation group is 1

For 802.11n (5GHz) the Power level is always 10 and the modulation group is 1

For 802.11a the Power level is always 10 and the modulation group is 1

For 802.11ac the Power level is always 6 and the modulation group is 1

If a continuous burst is required use instead of the command 25 the command 17:

17 1 4

```
Enter option: 17 1 4
DutIf_SetTxDataRate: 0x00000000
TRPC ID: 2
DutIf_SetTxContMode: 0x00000000
Enter option:
```

11b		11g/a		11n		11ac	
ID	DataRate	ID	DataRate	ID	DataRate	ID	DataRate
1	1M	6	6M	15	MCS0	101	VHT_SS1_MCS0
2	2M	7	9M	16	MCS1	102	VHT_SS1_MCS1
3	5.5M	8	12M	17	MCS2	103	VHT_SS1_MCS2
4	11M	9	18M	18	MCS3	104	VHT_SS1_MCS3
		10	24M	19	MCS4	105	VHT_SS1_MCS4
		11	36M	20	MCS5	106	VHT_SS1_MCS5
		12	48M	21	MCS6	107	VHT_SS1_MCS6
		13	54M	22	MCS7	108	VHT_SS1_MCS7
						109	VHT_SS1_MCS8
						110	VHT_SS1_MCS9

In order to stop the TX:

17 0

```
Enter option: 17 0
DutIf_SetTxContMode: 0x00000000
Enter option:
```

3.7. Worst case identification

From AIVIL42P0 (FCC ID: YBN-AIVIL42P0 and ISED: 9595A-AIVIL42P0) worst case mode and worst case bandwidth was identified as:

- a-mode
- 20MHz

4. Description of test system set-up's

4.1. Test system set-up for conducted measurements on antenna port

Conducted Set-up W1

Conducted RF-Setup 1 (W1 Set-up)

General description:

The EUT's RF-signal is coupled out by a suitable antenna coupling connector (1). The signal is first attenuated (2) then connected to the power meter (3) for conducted power measurements. The specific attenuation loss is determined prior to the measurement within a set-up attenuation measurement. These are then taken into account by correcting the measurement readings.

Schematic:

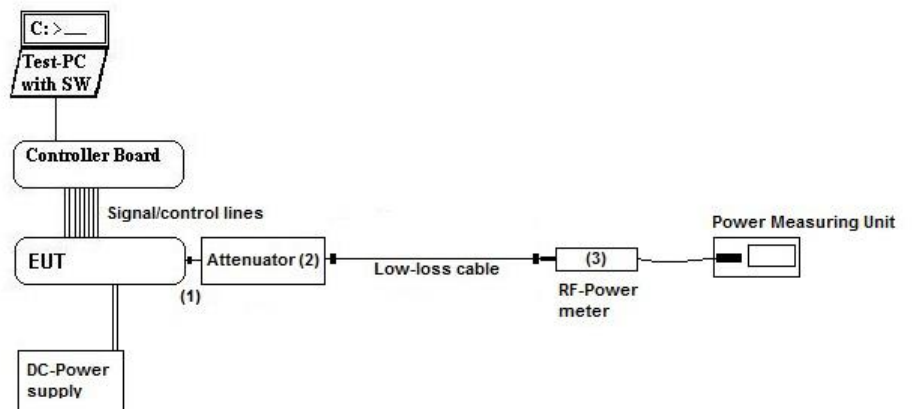

Testing method:

ANSI C63.10:2013,
KDB 789033 D02 General UNII Test Procedures New Rules v01r04

Used Equipment

Passive Elements	Test Equipment	Remark:
<input checked="" type="checkbox"/> 20 dB Attenuator	<input checked="" type="checkbox"/> Power Meter	See List of equipment under each test case and chapter 8 for calibration info
<input checked="" type="checkbox"/> Low loss RF-cables	<input checked="" type="checkbox"/> DC-Power Supply	
<input checked="" type="checkbox"/>	<input checked="" type="checkbox"/> Spectrum-Analyser	

Measurement uncertainty

See chapter 5.7

Conducted Set-up W2

Conducted RF-Setup 2 (W2 Set-up)

General description:

The EUT's RF-signal is coupled out by a suitable antenna coupling connector (1). The signal is first attenuated (2) then connected to spectrum-analyzer (4) for RF-conducted measurements. The specific attenuation loss is determined prior to the measurement within a set-up attenuation measurement. These are then taken into account by correcting the measurement readings of the spectrum-analyzer.

Schematic:

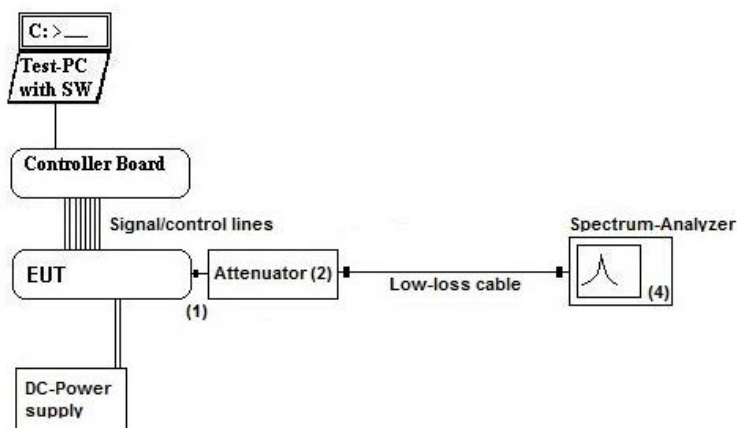

Testing method:

ANSI C63.10:2013,
KDB 789033 D02 General UNII Test Procedures New Rules v01r04

Used Equipment

Passive Elements	Test Equipment	Remark:
<input checked="" type="checkbox"/> 20 dB Attenuator	<input checked="" type="checkbox"/> Power Meter	See List of equipment under each test case and chapter 8 for calibration info
<input checked="" type="checkbox"/> Low loss RF-cables	<input checked="" type="checkbox"/> DC-Power Supply	
	<input checked="" type="checkbox"/> Spectrum-Analyser	

Measurement uncertainty

See chapter 5.7

4.2. Test system set-up for radiated magnetic field measurements below 30 MHz

Specification: ANSI C63.4-2014 §5.3, §8.2.1, §8.3.1.1+§8.3.2.1 , ANSI C63.10-2013 chapter 6.4 (§6.4.4.2)

General Description: Evaluating the radiated field emissions are done first by an exploratory emission measurement and a final measurement for most critical frequencies determined.

The loop antenna was placed at 1 m height above ground plane and 3 m measurement distance from set-up for investigations. Because of reduced measurement distance, correction data were applied, as stated in chapter “General Limit - Radiated field strength emissions below 30 MHz“. The tests are performed in the semi anechoic room recognized by the regulatory commission.

Schematic:

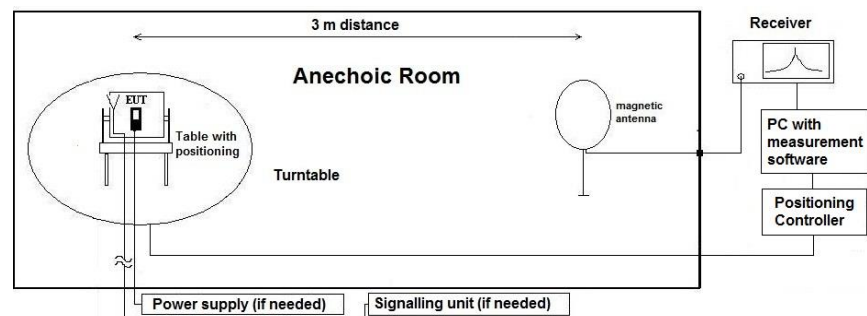

Testing method:

Exploratory, preliminary measurement

The EUT and its associated accessories are placed on a non-conductive position manipulator (tipping device) of 0.8 m height which is placed on the turntable. By rotating the turntable (step 90°, range 0° to 360°) and the EUT itself either on 3-orthogonal axis (portable equipment) or 2-orthogonal axis (defined operational position of EUT), the emission spectrum was recorded. The loop antenna was moved at least to 2-perpendicular axes (antenna vector in direction of EUT and parallel to EUT) in order to maximize the emissions. The results are documented in a diagram. Critical frequencies (low margin to limit) are saved within a data reduction table for further investigations. If various operating modes are supported, further investigations are made to find the worst-case. Also the interconnection cables and equipment position were varied in order to maximize the emissions.

Final measurement on critical frequencies

Based on the exploratory measurements, the most critical frequencies are re-measured by maintaining the EUT's worst-case operation mode, cable position, etc.

First a frequency zoom around the critical frequency is done to locate the frequency more precisely. After this step, for all identified critical frequencies, the maximum peak was determined.

Following parameters were varied: the turntable angle continuously in the range 0 to 360 degree, the EUT itself either over 3-orthogonal axis (not defined usage position) or 2-orthogonal axis (defined usage position).

On the determined worst-case position, a final measurement with necessary bandwidth and detector according standard has been carried out.

Formula:

$$E_C = E_R + AF + C_L + D_F - G_A$$

$$M = L_T - E_C$$

AF = Antenna factor

C_L = Cable loss

D_F = Distance correction factor

E_C = Electrical field – corrected value

E_R = Receiver reading

G_A = Gain of pre-amplifier (if used)

L_T = Limit

M = Margin

All units are dB-units, positive margin means value is below limit.

Distance correction:

Reference for applied correction (extrapolating) factors due to reduced measurement distance:

ANSI C63.10:2013, §6.4.4.2 - Equations (2) + (3) + (4)

4.3. Test system set-up for radiated electric field measurement 30 MHz to 1 GHz

Specification: ANSI C63.4-2014 chapter 8.2.3, ANSI C63.10-2013 chapter 6.5

General Description: Evaluating the field emissions have to be done first by an exploratory emissions measurement and a final measurement for most critical frequencies. The tests are performed in a NSA-compliant semi anechoic room (SAR) recognized by the regulatory commissions.

Schematic:

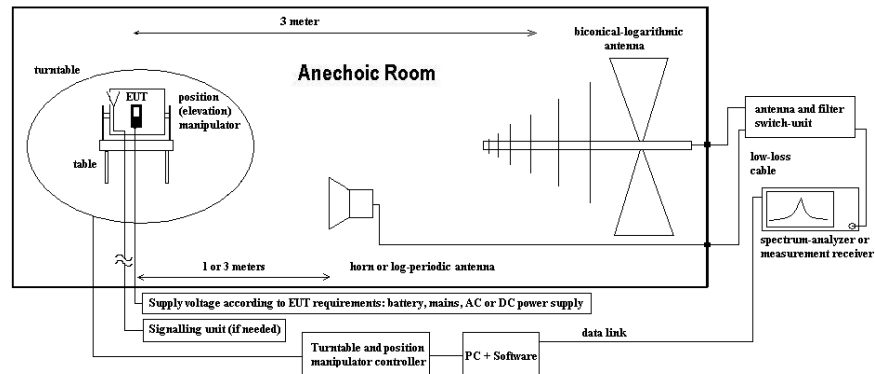

Testing method:

Exploratory, preliminary measurements

The EUT and its associated accessories are placed on a non-conductive position manipulator (tipping device) of 0.8 m height which is placed on the turntable. By rotating the turntable (range 0° to 360°, step 90°) and the EUT itself either on 3-orthogonal axis (portable equipment) or 2-orthogonal axis (defined operational position of EUT) the emission spectrum and its characteristics was recorded with an EMI-receiver, broadband antenna and software.

Measurement antenna: horizontal and vertical, heights: 1,0 m and 1,82 m as worst-case determined by an exploratory emission measurements. The results are documented in a diagram. Critical frequencies (low margin to limit) are saved within a table for further investigations. If various operating modes are supported, further investigations are made to find the worst-case of them. Also the interconnection cables and equipment position were varied in order to maximize the emissions.

Final measurement on critical frequencies

Based on the exploratory measurements, the most critical frequencies are re-measured by maintaining the EUT's worst-case operation mode, cable position, etc. either on 10m OATS or 3m semi-anechoic room.

First a frequency zoom around the critical frequency is done to locate the frequency more precisely. After this step, for all identified critical frequencies, the maximum peak was determined.

Following parameters were varied: the turntable angle continuously in the range 0 to 360 degree, the EUT itself either over 3-orthogonal axis (not defined usage position) or 2-orthogonal axis (defined usage position). The measurement antenna height between 1 m and 4 m.

On the determined worst-case position, a final measurement with necessary bandwidth and detector according standard has been carried out.

Formula:

$$E_C = E_R + AF + C_L + D_F - G_A \quad (1)$$

$$M = L_T - E_C \quad (2)$$

- AF = Antenna factor
- C_L = Cable loss
- D_F = Distance correction factor (if used)
- E_C = Electrical field – corrected value
- E_R = Receiver reading
- G_A = Gain of pre-amplifier (if used)
- L_T = Limit
- M = Margin

All units are dB-units, positive margin means value is below limit.

4.4. Test system set-up for radiated electric field measurement above 1 GHz

Specification: ANSI C63.4-2014 chapter 8.3, ANSI C63.10-2013 chapter 6.6.3.3 & 6.6.4

General Description: Evaluating the emissions have to be done first by an exploratory emissions measurement and a final measurement for most critical frequencies. The tests are performed in a CISPR 16-1-4:2010 compliant fully anechoic room (FAR) recognized by the regulatory commission. The measurement distance was set to 3 meter for frequencies up to 18 GHz and 2 meter above 18 GHz. A logarithmic periodic antenna is used for the frequency range 30 MHz to 1 GHz. Horn antennas are used for frequency range 1 GHz to 40 GHz. The EUT is aligned within 3 dB beam width of the measurement antenna with three orthogonal axis measurements on the EUT.

Schematic:

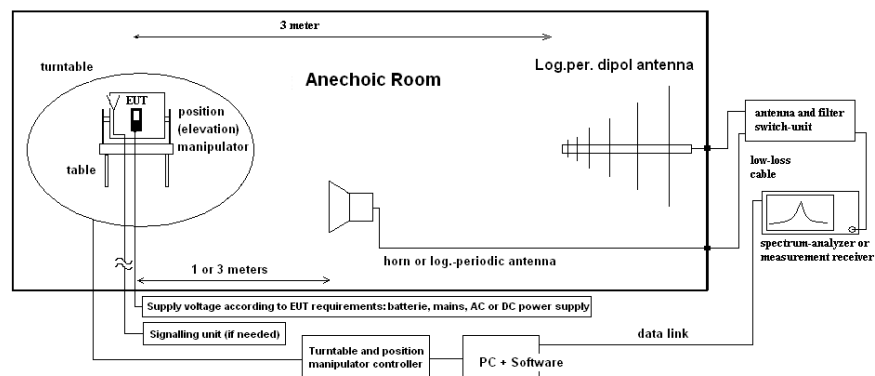

Testing method:

Exploratory, preliminary measurements

The EUT and its associated accessories are placed on a non-conductive position manipulator (tipping device) of 1.55 m height which is placed on the turntable. By rotating the turntable (range 0° to 360°, step 15°) and the EUT itself either on 3-orthogonal axis (portable equipment) or 2-orthogonal axis (defined operational position of EUT) the emission spectrum and its characteristics was recorded with an EMI-receiver, broadband antenna and software. The measurements are performed in horizontal and vertical polarization of the measurement antennas. The results are documented in a diagram. Critical frequencies (low margin to limit) are saved within a table for further investigations. If various operating modes are supported, further investigations are made to find the worst-case of them. Also the interconnection cables and equipment position were varied in order to maximize the emissions.

Final measurement on critical frequencies

Based on the exploratory measurements, the most critical frequencies are re-measured by maintaining the EUT's worst-case operation mode, cable position, etc.

First a frequency zoom around the critical frequency is done to locate the frequency more precisely. After this step, for all identified critical frequencies, the maximum peak was determined. Following parameters were varied: the turntable angle continuously in the range 0 to 360 degree, the EUT itself over 3-orthogonal axis and the height for EUT with large dimensions.

On the determined worst-case position, a final measurement with necessary bandwidth and detector according standard has been carried out. On the determined worst-case position, a final measurement with necessary bandwidth and detector according standard has been carried out.

Formula:

$$E_C = E_R + AF + C_L + D_F - G_A \quad (1)$$

$$M = L_T - E_C \quad (2)$$

E_C = Electrical field – corrected value

E_R = Receiver reading

M = Margin

L_T = Limit

AF = Antenna factor

C_L = Cable loss

D_F = Distance correction factor (if used)

G_A = Gain of pre-amplifier (if used)

All units are dB-units, positive margin means value is below limit.

5. Measurements

5.1. General Limit – Maximum power output conducted

5.1.1. Test location and equipment (for reference numbers please see chapter 'List of test equipment')

test location	<input checked="" type="checkbox"/> CETECOM Essen (Chapter. 2.2.1)	<input type="checkbox"/> 443 System CTC-FAR-EMI-	<input type="checkbox"/> Please see Chapter. 2.2.3
test site	<input type="checkbox"/> 441 EMI SAR	<input type="checkbox"/> 487 SAR NSA	<input type="checkbox"/> 347 Radio.lab. <input checked="" type="checkbox"/> TS 8997
receiver	<input type="checkbox"/> 377 ESCS30	<input type="checkbox"/> 001 ESS	<input type="checkbox"/> 489 ESU 40
spectr. analys.	<input type="checkbox"/> 584 FSU	<input type="checkbox"/> 120 FSEM	<input type="checkbox"/> 264 FSEK <input type="checkbox"/> 489 ESU 40
antenna	<input type="checkbox"/> 574 BTA-L	<input type="checkbox"/> 133 EMCO3115	<input type="checkbox"/> 302 BBHA9170 <input type="checkbox"/> 289 CBL 6141 <input type="checkbox"/> 030 HFH-Z2 <input type="checkbox"/> 477 GPS
signaling	<input type="checkbox"/> 392 MT8820A	<input type="checkbox"/> 436 CMU	<input type="checkbox"/> 547 CMU
otherwise	<input checked="" type="checkbox"/> 266 NRV-Z31	<input checked="" type="checkbox"/> 600 NRVD	<input type="checkbox"/> 110 USB LWL <input type="checkbox"/> 482 Filter Matrix <input type="checkbox"/> 378 RadiSense <input type="checkbox"/> 693 TS8997
DC power	<input checked="" type="checkbox"/> 671 EA-3013S	<input type="checkbox"/> 463 HP3245A	<input type="checkbox"/> 459 EA 2032-50 <input type="checkbox"/> 268 EA- 3050 <input type="checkbox"/> 494 AG6632A <input type="checkbox"/> 498 NGPE 40
otherwise	<input type="checkbox"/> 331 HC 4055	<input type="checkbox"/> 248 6 dB Attenuator	<input type="checkbox"/> 529 Power divider <input checked="" type="checkbox"/> - cable OTA20
	<input checked="" type="checkbox"/> 530 10dB Attenuator	<input type="checkbox"/> K 4 Cable kit	
Supply voltage	<input checked="" type="checkbox"/> 13.5 V DC	<input type="checkbox"/> 060 110 V 60 Hz via PAS 5000	

5.1.2. Reference

FCC	<input checked="" type="checkbox"/> Part 15 Subpart C, §15.407(a)(1)(2)(3)(4)
ISED	<input checked="" type="checkbox"/> RSS-247, Issue 2
ANSI	<input checked="" type="checkbox"/> C63.10-2013
KDB Guidance no.	<input checked="" type="checkbox"/> 789033 D02 General UNII test procedures v01r03: Subchapter E, Method PM (3)(a) <input checked="" type="checkbox"/> 662911 D01 V02r01 (MIMO, Smart-antenna)
Limits (For the band 5600–5650 MHz, no operation in Canada is permitted)	<input checked="" type="checkbox"/> U-NII 1: 5.15-5.25 GHz: FCC Outdoor access point: 1W + antenna gain max. 6dBi + Elevation > 30° 21 dBm EIRP FCC Indoor Access Point: 1W + antenna gain max. 6dBi FCC Mobile & Portable client: 250mW + antenna gain max. 6dBi ISED: <input type="checkbox"/> E.I.R.P. max. 200mW or 10+10log ₁₀ (B) whichever power is less <input checked="" type="checkbox"/> OEM device installed on vehicles: 30mW EIRP or 1.76 + 10log ₁₀ (B) + TPC capability <input checked="" type="checkbox"/> U-NII2: 5.25-5.35 GHz: FCC: lesser of 250mW or 11dBm+10log ₁₀ (B) ISED: <input type="checkbox"/> max. conducted output power: 250mW or 11dBm+10log ₁₀ (B) + Antenna gain < 6dBi <input type="checkbox"/> EIRP Elevation Mask requirements if max. EIRP>200mW <input type="checkbox"/> Max. EIRP 1Watt or 17+10log ₁₀ (B) whichever power less <input checked="" type="checkbox"/> OEM device installed on vehicles: 30mW EIRP or 1.76 + 10log ₁₀ (B) + TPC capability <input checked="" type="checkbox"/> U-NII2extension: 5.470-5.725 GHz: FCC: lesser of 250mW or 11dBm+10log ₁₀ (B) + Antenna gain < 6dBi ISED: <input checked="" type="checkbox"/> Lesser of: lesser of 250mW or 11dBm+10log ₁₀ (B) <input checked="" type="checkbox"/> Max. EIRP 1Watt or 17+10log ₁₀ (B) whichever power less <input type="checkbox"/> TPC required if MAX. EIRP > 500mW <input checked="" type="checkbox"/> U-NII3: 5.725-5.850 GHz: FCC/ISED: <input checked="" type="checkbox"/> max. conducted power: 1 Watt (30dBm) <input checked="" type="checkbox"/> Antenna gain less 6dBi <input type="checkbox"/> Antenna gain more 6dBi (-> reduction necessary)

5.1.3. EUT settings:

The EUT was instructed to send with maximum power (if adjustable) according applicants instructions. Different modulation characteristics have been checked, e.g. data rates which EUT can operate. Three operating frequencies within each operating band have been selected.

5.1.4. Test condition and measurement test set-up

Signal ink to test system (if used):	<input type="checkbox"/> air link	<input type="checkbox"/> cable connection	<input checked="" type="checkbox"/> none
EUT-grounding	<input checked="" type="checkbox"/> none	<input type="checkbox"/> with power supply	<input type="checkbox"/> additional connection
Equipment set up	<input checked="" type="checkbox"/> table top 1.5m height	<input type="checkbox"/> floor standing	
Climatic conditions	Temperature: (22±3°C)	Rel. humidity: (40±20)%	
General measurement procedures	Please see chapter "Test system set-up for conducted RF-measurement at antenna Port" (W1 Set-up)		

5.1.5. RESULTS

APPLICANT'S DECLARED ANTENNA CHARACTERISTICS:

- Directional Gain < 6 dBi (measured: difference between measured conducted and radiated eirp. power)
- Directional Gain > 6 dBi (measured / applicant's declaration) -> conducted power reduction necessary

Antenna: please refer to

Maximum declared antenna gain [isotropic]: 3.5 dBi

Only worst case mode and bandwidth was tested. Other modulation types and data rates were not tested

5.1.5.1. FCC REQUIREMENT

Operational bands:	U-NII 1			U-NII-2A			U-NII 2C			U-NII-3		
Channel no.:	Channel 36 (5180MHz)	Channel 40 (5200MHz)	Channel 48 (5240MHz)	Channel 52 (5260MHz)	Channel 56 (5280MHz)	Channel 64 (5320MHz)	Channel 100 (5500MHz)	Channel 116 (5580MHz)	Channel 140 (5700MHz)	Channel 149 (5745MHz)	Channel 157 (5785MHz)	Channel 165 (5825MHz)
a-Mode/10dBm												
6	4,81	5,56	4,67	4,42	6,18	5,03	4,90	4,32	2,64	3,05	2,80	4,07
9	4,67	5,48	4,87	4,41	6,25	5,04	4,90	4,32	2,64	3,05	2,80	4,07
12	4,67	5,48	4,87	4,41	6,25	5,04	5,09	4,24	2,58	2,89	2,78	4,06
18	4,60	5,41	4,82	4,37	6,09	5,39	4,89	4,11	2,80	3,01	2,71	4,00
24	4,54	5,40	4,77	4,33	6,09	5,40	5,02	4,10	2,50	3,21	2,70	4,01
36	4,53	5,35	4,76	4,22	5,97	5,26	4,87	4,03	2,42	2,59	2,60	3,98
48	4,47	5,28	4,72	4,30	5,95	5,25	4,84	3,93	2,65	2,63	2,64	3,89
54	4,53	5,32	4,68	4,24	5,99	5,19	4,82	3,97	2,58	2,96	2,62	3,89
Operational bands:	U-NII 1			U-NII-2A			U-NII 2C			U-NII 2C		
FCC-Limits output power [dBm]	24,00			24,00			24,00			30,00		
FCC-Limits EIRP [dBm]	30,00			30,00			30,00			36,00		
Limit Check:	Limit Check:											
Highest conducted power value over channels and modulations:	5,56			6,25			5,09			4,07		
Margin to Limit output power:	18,44			17,76			18,92			25,93		
Declared antenna Gain max:	3,40			3,50			1,40			-0,10		
Peak EIRP:	8,96			9,75			6,49			3,97		
Margin to Limit EIRP:	21,04			20,26			23,52			32,03		
Verdict:	pass			pass			pass			pass		

Remark: --

5.1.5.2. ISED REQUIRMENT ONLY**RSS 247 section 6.2.1.1 and section 6.2.2.1****Frequency band 5150-5250MHz and 5250-5350MHz**

For OEM devices installed in vehicles, the maximum e.i.r.p. shall not exceed 30 mW or $1.76 + 10 \log_{10} B$, dBm, whichever is less. Devices shall implement transmitter power control (TPC) in order to have the capability to operate at least 3 dB below the maximum permitted e.i.r.p. of 30 mW ($14.78\text{dBm} - 3\text{dB} = 11.78\text{dBm}$)

Max EIRP = 9.75dBm < 11.78dBm

Verdict: pass

RSS 247 section 6.2.3**Frequency band 5600-5650MHz**

Until further notice, devices subject to this section shall not be capable of transmitting in the band 5600-5650 MHz. This restriction is for the protection of Environment Canada's weather radars operating in this band.

5.2. General Limit - Radiated field strength emissions below 30 MHz

5.2.1. Test location and equipment

test location	<input checked="" type="checkbox"/> CETECOM Essen (Chapter. 2.2.1)	<input type="checkbox"/> Please see Chapter. 2.2.2	<input type="checkbox"/> Please see Chapter. 2.2.3
test site	<input checked="" type="checkbox"/> 441 EMI SAR	<input type="checkbox"/> 487 SAR NSA	<input type="checkbox"/> 347 Radio.lab.
receiver	<input type="checkbox"/> 377 ESCS30	<input checked="" type="checkbox"/> 001 ESS	<input type="checkbox"/>
spectr. analys.	<input type="checkbox"/> 584 FSU	<input type="checkbox"/> 120 FSEM	<input type="checkbox"/> 264 FSEK
antenna	<input type="checkbox"/> 574 BTA-L	<input type="checkbox"/> 133 EMCO3115	<input type="checkbox"/> 302 BBHA9170
signaling	<input type="checkbox"/> 392 MT8820A	<input type="checkbox"/> 371 CBT32	<input type="checkbox"/> 547 CMU
otherwise	<input type="checkbox"/> 400 FTC40x15E	<input type="checkbox"/> 401 FTC40x15E	<input type="checkbox"/> 110 USB LWL
DC power	<input type="checkbox"/> 671 EA-3013S	<input checked="" type="checkbox"/> 457 EA 3013A	<input type="checkbox"/> 459 EA 2032-50
Supply voltage	<input type="checkbox"/> 230 V 50 Hz via public mains	<input checked="" type="checkbox"/> 13.5 V DC	<input type="checkbox"/> 268 EA- 3050
			<input type="checkbox"/> 494 AG6632A
			<input type="checkbox"/> 378 RadiSense
			<input type="checkbox"/> 477 GPS
			<input type="checkbox"/> 354 NGPE 40

5.2.2. Requirements

FCC	Part 15, Subpart C, §15.205 & §15.209		
ANSI	C63.10-2013		
Frequency [MHz]	Field strength limit		Distance [m]
	[µV/m]	[dBµV/m]	
0.009 – 0.490	2400/f (kHz)	67.6 – 20Log(f) (kHz)	300
0.490 – 1.705	24000/f (kHz)	87.6 – 20Log(f) (kHz)	30
1.705 – 30	30	29.5	30
			Remarks
			Correction factor used due to measurement distance of 3 m
			Correction factor used due to measurement distance of 3 m
			Correction factor used due to measurement distance of 3 m

5.2.3. Test condition and test set-up

Signal link to test system (if used):	<input type="checkbox"/> air link	<input type="checkbox"/> cable connection	<input checked="" type="checkbox"/> none
EUT-grounding	<input checked="" type="checkbox"/> none	<input type="checkbox"/> with power supply	<input type="checkbox"/> additional connection
Equipment set up	<input checked="" type="checkbox"/> table top	<input type="checkbox"/> floor standing	
Climatic conditions	Temperature: (22±3°C)		Rel. humidity: (40±20)%
EMI-Receiver or Analyzer Settings	Scan data	<input checked="" type="checkbox"/> 9 – 150 kHz RBW/VBW = 200 Hz Scan step = 80 Hz <input checked="" type="checkbox"/> 150 kHz – 30 MHz RBW/VBW = 9 kHz Scan step = 4 kHz <input type="checkbox"/> other:	
	Scan-Mode Detector Mode: Sweep-Time	<input checked="" type="checkbox"/> 6 dB EMI-Receiver Mode <input type="checkbox"/> 3dB Spectrum analyser Mode Peak (pre-measurement) and Quasi-PK/Average (final if applicable) Repetitive-Scan, max-hold Coupled – calibrated display if continuous signal otherwise adapted to EUT’s individual transmission duty-cycle	
General measurement procedures	Please see chapter “Test system set-up radiated magnetic field measurements below 30 MHz”		

5.2.4. Radiated Field Strength Emissions – 9 kHz to 30 MHz Results

Radiated Field Strength Emissions – 9 kHz to 30 MHz										
Temperature :+21 °C		Technology: WLAN 5 GHz 802.11a/n			TX-Fixed Channel (Modulated)					
Diagram No. (Remark 1)	Test Settings				Set-up no.	OP-mode no.	Used detector			Verdict
	Mode	B.W.	Data Rate	Frequency Band - Channel (Frequency)			PK	AV	QP	
2.01a+b	a Mode	20 MHz	6 Mbit	ch 040	1	1	<input checked="" type="checkbox"/>	<input type="checkbox"/>	<input type="checkbox"/>	Pass
2.02a+b	a Mode	20 MHz	9 Mbit	ch 056	1	1	<input checked="" type="checkbox"/>	<input type="checkbox"/>	<input type="checkbox"/>	Pass
2.03a+b	a Mode	20 MHz	12 Mbit	ch 100	1	1	<input checked="" type="checkbox"/>	<input type="checkbox"/>	<input type="checkbox"/>	Pass
2.04a+b	a Mode	20 MHz	6 Mbit	ch 149	1	1	<input checked="" type="checkbox"/>	<input type="checkbox"/>	<input type="checkbox"/>	Pass
Remark 1: See diagrams in separate Annex 1										

5.2.5. Correction factors due to reduced meas. distance (f< 30 MHz)

The used correction factors when the measurement distance is reduced compared to regulatory measurement distance, are calculated according Extrapolation formulas valid for EUT's with maximum dimension of 0.625xLambda. Formula 2+3+4 as presented in ANSI C63.10, Chapter 6.4.4 are used for the calculations of proper extrapolation factors.

Frequency Range	f [kHz/MHz]	Lambda [m]	Far-Field Point [m]	Distance Limit accord. 15.209 [m]	1st Condition (d _{meas} < D _{near-field})	2te Condition (Limit distance bigger d _{near-field})	Distance Correction accord. Formula
kHz	9,00E+03	33333,33	5305,17	300	fulfilled	not fulfilled	-80,00
	1,00E+04	30000,00	4774,65		fulfilled	not fulfilled	-80,00
	2,00E+04	15000,00	2387,33		fulfilled	not fulfilled	-80,00
	3,00E+04	10000,00	1591,55		fulfilled	not fulfilled	-80,00
	4,00E+04	7500,00	1193,66		fulfilled	not fulfilled	-80,00
	5,00E+04	6000,00	954,93		fulfilled	not fulfilled	-80,00
	6,00E+04	5000,00	795,78		fulfilled	not fulfilled	-80,00
	7,00E+04	4285,71	682,09		fulfilled	not fulfilled	-80,00
	8,00E+04	3750,00	596,83		fulfilled	not fulfilled	-80,00
	9,00E+04	3333,33	530,52		fulfilled	not fulfilled	-80,00
	1,00E+05	3000,00	477,47		fulfilled	not fulfilled	-80,00
	1,25E+05	2400,00	381,97		fulfilled	not fulfilled	-80,00
	2,00E+05	1500,00	238,73		fulfilled	fulfilled	-78,02
	3,00E+05	1000,00	159,16		fulfilled	fulfilled	-74,49
	4,00E+05	750,00	119,37		fulfilled	fulfilled	-72,00
	4,90E+05	612,24	97,44		fulfilled	fulfilled	-70,23
	5,00E+05	600,00	95,49		fulfilled	not fulfilled	-40,00
	6,00E+05	500,00	79,58		fulfilled	not fulfilled	-40,00
7,00E+05	428,57	68,21	fulfilled	not fulfilled	-40,00		
8,00E+05	375,00	59,68	fulfilled	not fulfilled	-40,00		
9,00E+05	333,33	53,05	fulfilled	not fulfilled	-40,00		
MHz	1,00	300,00	47,75	30	fulfilled	not fulfilled	-40,00
	1,59	188,50	30,00		fulfilled	not fulfilled	-40,00
	2,00	150,00	23,87		fulfilled	fulfilled	-38,02
	3,00	100,00	15,92		fulfilled	fulfilled	-34,49
	4,00	75,00	11,94		fulfilled	fulfilled	-32,00
	5,00	60,00	9,55		fulfilled	fulfilled	-30,06
	6,00	50,00	7,96		fulfilled	fulfilled	-28,47
	7,00	42,86	6,82		fulfilled	fulfilled	-27,13
	8,00	37,50	5,97		fulfilled	fulfilled	-25,97
	9,00	33,33	5,31		fulfilled	fulfilled	-24,95
	10,00	30,00	4,77		fulfilled	fulfilled	-24,04
	10,60	28,30	4,50		fulfilled	fulfilled	-23,53
	11,00	27,27	4,34		fulfilled	fulfilled	-23,21
	12,00	25,00	3,98		fulfilled	fulfilled	-22,45
	13,56	22,12	3,52		fulfilled	fulfilled	-21,39
	15,00	20,00	3,18		fulfilled	fulfilled	-20,51
	15,92	18,85	3,00		fulfilled	fulfilled	-20,00
	17,00	17,65	2,81		not fulfilled	fulfilled	-20,00
	18,00	16,67	2,65		not fulfilled	fulfilled	-20,00
	20,00	15,00	2,39		not fulfilled	fulfilled	-20,00
	21,00	14,29	2,27		not fulfilled	fulfilled	-20,00
23,00	13,04	2,08	not fulfilled	fulfilled	-20,00		
25,00	12,00	1,91	not fulfilled	fulfilled	-20,00		
27,00	11,11	1,77	not fulfilled	fulfilled	-20,00		
29,00	10,34	1,65	not fulfilled	fulfilled	-20,00		
30,00	10,00	1,59	not fulfilled	fulfilled	-20,00		

5.3. General Limit - Radiated field strength emissions, 30 MHz - 1 GHz

5.3.1. Test location and equipment

test location	<input checked="" type="checkbox"/> CETECOM Essen (Chapter. 2.2.1)	<input type="checkbox"/> Please see Chapter. 2.2.2		<input type="checkbox"/> Please see Chapter. 2.2.3	
test site	<input checked="" type="checkbox"/> 441 EMI SAR	<input checked="" type="checkbox"/> 487 SAR NSA			
receiver	<input type="checkbox"/> 377 ESCS30	<input checked="" type="checkbox"/> 001 ESS	<input type="checkbox"/> 489 ESU 40	<input type="checkbox"/> 620 ESU 26	
spectr. analys.	<input type="checkbox"/> 584 FSU	<input type="checkbox"/> 120 FSEM	<input type="checkbox"/> 264 FSEK		
antenna	<input checked="" type="checkbox"/> 574 BTA-L	<input type="checkbox"/> 133 EMCO3115	<input type="checkbox"/> 302 BBHA9170	<input type="checkbox"/> 289 CBL 6141	<input type="checkbox"/> 030 HFH-Z2 <input type="checkbox"/> 477 GPS
signaling	<input type="checkbox"/> 392 MT8820A	<input type="checkbox"/> 371 CBT32	<input type="checkbox"/> 547 CMU	<input type="checkbox"/> 594 CMW	
otherwise	<input type="checkbox"/> 400 FTC40x15E	<input type="checkbox"/> 401 FTC40x15E	<input type="checkbox"/> 110 USB LWL	<input checked="" type="checkbox"/> 482 Filter Matrix	
DC power	<input type="checkbox"/> 671 EA-3013S	<input checked="" type="checkbox"/> 457 EA 3013A	<input type="checkbox"/> 459 EA 2032-50	<input type="checkbox"/> 268 EA- 3050	<input type="checkbox"/> 494 AG6632A <input type="checkbox"/> 498 NGPE
Supply voltage	<input type="checkbox"/> 230 V 50 Hz via public mains		<input checked="" type="checkbox"/> 24V DC		

5.3.2. Requirements/Limits

FCC		<input type="checkbox"/> Part 15 Subpart B, §15.109, class B <input checked="" type="checkbox"/> Part 15 Subpart C, §15.209 @ frequencies defined in §15.205	
ANSI		<input type="checkbox"/> C63.4-2014 <input checked="" type="checkbox"/> C63.10-2013	
Limit	Frequency [MHz]	Radiated emissions limits, 3 meters	
		QUASI Peak [μ V/m]	QUASI-Peak [dB μ V/m]
	30 - 88	100	40.0
	88 - 216	150	43.5
	216 - 960	200	46.0
	above 960	500	54.0

5.3.3. Restricted bands of operation (FCC §15.205 / RSS-Gen, Issue 5)

MHz	MHz	MHz	GHz
0.090-0.110	16.42-16.423	399.9-410	4.5-5.15
0.495-0.505	16.69475-16.69525	608-614	5.35-5.46
2.1735-2.1905	16.80425-16.80475	960-1240	7.25-7.75
4.125-4.128	25.5-25.67	1300-1427	8.025-8.5
4.20725-4.20775	37.5-38.25	1645.5-1646.5	9.3-9.5
6.215-6.218	73-74.6	1660-1710	10.6-12.7
6.26775-6.26825	74.8-75.2	1718.8-1722.2	13.25-13.4
6.31175-6.31225	108-121.94	2200-2300	14.47-14.5
8.291-8.294	123-138	2310-2390	15.35-16.2
8.362-8.366	149.9-150.05	2483.5-2500	17.7-21.4
8.37625-8.38675	156.52475-156.52525	2690-2900	22.01-23.12
8.41425-8.41475	156.7-156.9	3260-3267	23.6-24.0
12.29-12.293	162.0125-167.17	3332-3339	31.2-31.8
12.51975-12.52025	167.72-173.2	3345.8-3358	36.43-36.5
12.57675-12.57725	240-285	3600-4400	--
13.36-13.41	322-335.4	--	--

Remark: only spurious emissions are allowed within these frequency bands not exceeding the limits per §15.209

5.3.4. Test condition and measurement test set-up

Signal link to test system (if used):		<input type="checkbox"/> air link	<input type="checkbox"/> cable connection	<input checked="" type="checkbox"/> none
EUT-grounding		<input checked="" type="checkbox"/> none	<input type="checkbox"/> with power supply	<input type="checkbox"/> additional connection
Equipment set up		<input checked="" type="checkbox"/> table top 0.8m height		<input type="checkbox"/> floor standing
Climatic conditions		Temperature: (22±3°C)		Rel. humidity: (40±20)%
EMI-Receiver (Analyzer) Settings	Scan frequency range:	<input checked="" type="checkbox"/> 30 – 1000 MHz <input type="checkbox"/> other:		
	Scan-Mode	<input checked="" type="checkbox"/> 6 dB EMI-Receiver Mode <input type="checkbox"/> 3 dB spectrum analyser mode		
	Detector	Peak / Quasi-peak		
	RBW/VBW	100 kHz/300 kHz		
	Mode:	Repetitive-Scan, max-hold		
Scan step	80 kHz			
Sweep-Time	Coupled – calibrated display if continuous tx-signal otherwise adapted to EUT's individual duty-cycle			
General measurement procedures		Please see chapter "Test system set-up for electric field measurement in the range 30 MHz to 1 GHz"		

5.3.5. Radiated Field Strength Emissions – 30 MHz to 1 GHz Results

Radiated Field Strength Emissions – 30 MHz to 1 GHz										
Temperature :+21 °C		Technology: WLAN 5 GHz 802.11a			TX-Fixed Channel (Modulated)					
Diagram No. (Remark 1)	Test Settings				Set-up no.	OP-mode no.	Used detector			Verdict
	Mode	B.W.	Data Rate	Frequency Band - Channel (Frequency)			PK	AV	QP	
3.01a+b	a Mode	20 MHz	6 Mbit	ch 040	1	1	<input checked="" type="checkbox"/>	<input type="checkbox"/>	<input type="checkbox"/>	Pass
3.02a+b	a Mode	20 MHz	9 Mbit	ch 056	1	1	<input checked="" type="checkbox"/>	<input type="checkbox"/>	<input type="checkbox"/>	Pass
3.03a+b	a Mode	20 MHz	12 Mbit	ch 100	1	1	<input checked="" type="checkbox"/>	<input type="checkbox"/>	<input type="checkbox"/>	Pass
3.04a+b	a Mode	20 MHz	6 Mbit	ch 149	1	1	<input checked="" type="checkbox"/>	<input type="checkbox"/>	<input type="checkbox"/>	Pass

5.4. General Limit - Radiated emissions, above 1 GHz

5.4.1. Test location and equipment FAR

test site	<input type="checkbox"/> 441 EMI SAR	<input type="checkbox"/> 348 EMI cond.	<input checked="" type="checkbox"/> 443 EMI FAR	<input type="checkbox"/> 347 Radio.lab.	<input type="checkbox"/> 337 OATS	<input type="checkbox"/>
spectr. analys.	<input type="checkbox"/> 584 FSU	<input type="checkbox"/> 120 FSEM	<input type="checkbox"/> 264 FSEK	<input checked="" type="checkbox"/> 489 ESU 40	<input type="checkbox"/>	<input type="checkbox"/>
antenna meas	<input type="checkbox"/> 574 BTA-L	<input type="checkbox"/> 289 CBL 6141	<input type="checkbox"/> 608 HL 562	<input checked="" type="checkbox"/> 549 HL025	<input checked="" type="checkbox"/> 302 BBHA9170	<input type="checkbox"/> 477 GPS
antenna meas	<input type="checkbox"/> 123 HUF-Z2	<input type="checkbox"/> 132 HUF-Z3	<input type="checkbox"/> 030 HFH-Z2	<input type="checkbox"/> 376 BBHA9120E		<input type="checkbox"/>
antenna subst	<input type="checkbox"/> 071 HUF-Z2	<input type="checkbox"/> 020 EMCO3115	<input type="checkbox"/> 063 LP 3146	<input type="checkbox"/> 303 BBHA9170	<input type="checkbox"/>	<input type="checkbox"/>
multimeter	<input type="checkbox"/> 341 Fluke 112	<input type="checkbox"/>	<input type="checkbox"/>	<input type="checkbox"/>	<input type="checkbox"/>	<input type="checkbox"/>
signaling	<input type="checkbox"/> 392 MT8820A	<input type="checkbox"/> 371 CBT32	<input type="checkbox"/> 547 CMU	<input type="checkbox"/> 594 CMW		
DCpower	<input type="checkbox"/> 611 E3632A	<input checked="" type="checkbox"/> 087 EA3013	<input type="checkbox"/> 354 NGPE 40	<input type="checkbox"/> 349 car battery	<input type="checkbox"/> 350 Car battery	<input type="checkbox"/>
Supply voltage	<input type="checkbox"/> 230 V 50 Hz via public mains		<input checked="" type="checkbox"/> 13.5 V DC			

5.4.2. Requirements/Limits

FCC	<input type="checkbox"/> Part 15 Subpart B, §15.109 class B <input checked="" type="checkbox"/> Part 15 Subpart C, §15.209 for frequencies defined in §15.205 <input checked="" type="checkbox"/> Part 15 Subpart C, §15.407(b)(1)(2)(3)(4)(5)(6)(7)(8)			
ANSI	<input type="checkbox"/> C63.4-2014 <input checked="" type="checkbox"/> C63.10-2013			
Frequency [MHz]	Limits			
	AV [µV/m]	AV [dBµV/m]	Peak [µV/m]	Peak [dBµV/m] or [dBm/MHz]
above 1 GHz for frequencies as defined in §15.205	500	54.0	5000	74.0 dBµV/m
§15.407(b)(1)(2)(3)(4)	--	--	--	(b)(1): 5.15-5.25GHz: -27dBm eirp (b)(2): 5.25-5.35GHz: -27dBm eirp (b)(3): 5.47-5.725 GHz: -27dBm eirp (b)(4): 5.725-5.85GHz: Spectrum mask

5.4.3. Test condition and measurement test set-up

Signal link to test system (if used):	<input type="checkbox"/> air link	<input type="checkbox"/> cable connection	<input checked="" type="checkbox"/> none
EUT-grounding	<input checked="" type="checkbox"/> none	<input type="checkbox"/> with power supply	<input type="checkbox"/> additional connection
Equipment set up	<input checked="" type="checkbox"/> table top 1.5m height		<input type="checkbox"/> floor standing
Climatic conditions	Temperature: (22±3°C)		Rel. humidity: (40±20)%
Spectrum-Analyzer settings	Scan frequency range: <input checked="" type="checkbox"/> 1 – 18 GHz <input type="checkbox"/> 18 – 25 GHz <input checked="" type="checkbox"/> 18 – 40 GHz <input type="checkbox"/> other: Scan-Mode: <input checked="" type="checkbox"/> 6 dB EMI-Receiver Mode <input type="checkbox"/> 3 dB Spectrum analyser Mode Detector: Peak and Average RBW/VBW: 1 MHz / 3 MHz Mode: Repetitive-Scan, max-hold Scan step: 400 kHz Sweep-Time: Coupled – calibrated display if CW signal otherwise adapted to EUT's individual duty-cycle		
General measurement procedures	Please see chapter "Test system set-up for radiated electric field measurements above 1 GHz"		

5.4.4. Radiated Field Strength Emissions – 1 GHz to 40 GHz Results

Radiated Field Strength Emissions – 1 GHz to 7 GHz							
Temperature :+21 °C		Technology: WLAN 5 GHz 802.11a/n		TX-Fixed Channel (Modulated)			
Diagram No.	Test Settings Mode B.W. Data Rate Channel	Set-up no.	OP-mode no.	Used detector			Verdict
				PK	AV	QP	
8.01a	a Mode 20 MHz 6 Mbit ch 040	1	1	<input checked="" type="checkbox"/>	<input type="checkbox"/>	<input type="checkbox"/>	Pass
8.02a	a Mode 20 MHz 9 Mbit ch 056	1	1	<input checked="" type="checkbox"/>	<input type="checkbox"/>	<input type="checkbox"/>	Pass
8.03a	a Mode 20 MHz 12 Mbit ch 100	1	1	<input checked="" type="checkbox"/>	<input type="checkbox"/>	<input type="checkbox"/>	Pass
8.04a	a Mode 20 MHz 6 Mbit ch 149	1	1	<input checked="" type="checkbox"/>	<input type="checkbox"/>	<input type="checkbox"/>	Pass

5.4.5. Radiated Field Strength Emissions – 7 GHz to 18 GHz Results

Radiated Field Strength Emissions – 7 GHz to 18 GHz							
Temperature :+21 °C		Technology: WLAN 5 GHz 802.11a/n		TX-Fixed Channel (Modulated)			
Diagram No.	Test Settings Mode B.W. Data Rate Channel	Set-up no.	OP-mode no.	Used detector			Verdict
				PK	AV	QP	
8.01b	a Mode 20 MHz 6 Mbit ch 040	1	1	<input checked="" type="checkbox"/>	<input type="checkbox"/>	<input type="checkbox"/>	Pass
8.02b	a Mode 20 MHz 9 Mbit ch 056	1	1	<input checked="" type="checkbox"/>	<input type="checkbox"/>	<input type="checkbox"/>	Pass
8.03b	a Mode 20 MHz 12 Mbit ch 100	1	1	<input checked="" type="checkbox"/>	<input type="checkbox"/>	<input type="checkbox"/>	Pass
8.04b	a Mode 20 MHz 6 Mbit ch 149	1	1	<input checked="" type="checkbox"/>	<input type="checkbox"/>	<input type="checkbox"/>	Pass

5.4.6. Radiated Field Strength Emissions – 18 GHz to 40 GHz Results

Radiated Field Strength Emissions – 18 GHz to 40 GHz							
Temperature :+21 °C		Technology: WLAN 5 GHz 802.11a/n		TX-Fixed Channel (Modulated)			
Diagram No.	Test Settings Mode B.W. Data Rate Channel	Set-up no.	OP-mode no.	Used detector			Verdict
				PK	AV	QP	
8.01c	a Mode 20 MHz 6 Mbit ch 040	1	1	<input checked="" type="checkbox"/>	<input type="checkbox"/>	<input type="checkbox"/>	Pass
8.02c	a Mode 20 MHz 9 Mbit ch 056	1	1	<input checked="" type="checkbox"/>	<input type="checkbox"/>	<input type="checkbox"/>	Pass
8.03c	a Mode 20 MHz 12 Mbit ch 100	1	1	<input checked="" type="checkbox"/>	<input type="checkbox"/>	<input type="checkbox"/>	Pass
8.04c	a Mode 20 MHz 6 Mbit ch 149	1	1	<input checked="" type="checkbox"/>	<input type="checkbox"/>	<input type="checkbox"/>	Pass

5.5. RF-Parameter - Radiated Band-Edge compliance measurements

5.5.1. Test location and equipment FAR

test site	<input type="checkbox"/> 441 EMI SAR	<input type="checkbox"/> 348 EMI cond.	<input type="checkbox"/> 443 EMI FAR	<input checked="" type="checkbox"/> 347 Radio.lab.	<input type="checkbox"/> 337 OATS	<input type="checkbox"/>
spectr. analys.	<input type="checkbox"/> 584 FSU	<input type="checkbox"/> 120 FSEM	<input type="checkbox"/> 264 FSEK	<input checked="" type="checkbox"/> 714 FSW67	<input type="checkbox"/>	<input type="checkbox"/>
antenna meas	<input type="checkbox"/> 574 BTA-L	<input type="checkbox"/> 289 CBL 6141	<input type="checkbox"/> 608 HL 562	<input checked="" type="checkbox"/> 549 HL025	<input type="checkbox"/> 302 BBHA9170	<input type="checkbox"/> 477 GPS
antenna meas	<input type="checkbox"/> 123 HUF-Z2	<input type="checkbox"/> 132 HUF-Z3	<input type="checkbox"/> 030 HFH-Z2	<input type="checkbox"/>	<input type="checkbox"/>	<input type="checkbox"/>
antenna subst	<input type="checkbox"/> 071 HUF-Z2	<input type="checkbox"/> 020 EMCO3115	<input type="checkbox"/> 063 LP 3146	<input type="checkbox"/> 303 BBHA9170	<input type="checkbox"/>	<input type="checkbox"/>
multimeter	<input type="checkbox"/> 341 Fluke 112	<input type="checkbox"/>	<input type="checkbox"/>	<input type="checkbox"/>	<input type="checkbox"/>	<input type="checkbox"/>
signaling	<input type="checkbox"/> 392 MT8820A	<input type="checkbox"/> 371 CBT32	<input type="checkbox"/> 547 CMU	<input type="checkbox"/> 594 CMW	<input type="checkbox"/>	<input type="checkbox"/>
DC power	<input type="checkbox"/> 611 E3632A	<input type="checkbox"/> 087 EA3013	<input type="checkbox"/> 354 NGPE 40	<input type="checkbox"/> 349 car battery	<input type="checkbox"/> 350 Car battery	<input type="checkbox"/>
Supply voltage	<input type="checkbox"/> 230 V 50 Hz via public mains		<input checked="" type="checkbox"/> 13.5 V DC			

5.5.2. Requirements/Limits

FCC	<input type="checkbox"/> Part 15 Subpart B, §15.109 class B <input checked="" type="checkbox"/> Part 15 Subpart C, §15.209 for frequencies defined in §15.205 <input type="checkbox"/> Part 15 Subpart C, §15.407(b)(1)(2)(3)(4)			
ISED	<input checked="" type="checkbox"/> RSS-Gen., Issue 4, Chapter 8.9, Table 5+7 (transmitter licence exempt) <input type="checkbox"/> RSS-Gen., Issue 5, Chapter 7.3, Table 3 (receiver) <input type="checkbox"/> ICES-003, Issue 6, Chapter 6.2.2, Table 7 (class B) <input type="checkbox"/> RSS-247, Issue 2, Chapter 5.5 <input checked="" type="checkbox"/> RSS-247, Issue 2, Chapter 6.2			
ANSI	<input type="checkbox"/> C63.4-2014 <input checked="" type="checkbox"/> C63.10-2013			
Frequency [MHz]	Limits			
	AV [µV/m]	AV [dBµV/m]	Peak [µV/m]	Peak [dBµV/m] or [dBm/MHz]
above 1 GHz for frequencies as defined in §15.205 or RSS-Gen., Issue 9, §8.9 - Table 5	500	54.0	5000	74.0 dBµV/m
§15.407(b)(1)(2)(3)(4)	--	--	--	(b)(1): 5.15-5.25GHz: -27dBm eirp (b)(2): 5.25-5.35GHz: -27dBm eirp (b)(3): 5.47-5.725 GHz: -27dBm eirp (-17dBm/MHz eirp) (b)(4): 5.725-5.85GHz: Spectrum mask
RSS-247, Issue 2	--	--	--	§6.2.1.2 §6.2.2.2 §6.2.3.3 §6.2.4.2: Spectrum mask 27 to 15.6dBm 15.6dBm to 10dBm

5.5.3. Test condition and measurement test set-up

Signal link to test system (if used):	<input type="checkbox"/> air link	<input type="checkbox"/> cable connection	<input checked="" type="checkbox"/> none
EUT-grounding	<input checked="" type="checkbox"/> none	<input type="checkbox"/> with power supply	<input type="checkbox"/> additional connection
Equipment set up	<input checked="" type="checkbox"/> table top 1.5m height		<input type="checkbox"/> floor standing
Climatic conditions	Temperature: (22±3°C)		Rel. humidity: (40±20)%
Spectrum-Analyzer settings	Scan frequency range: <input type="checkbox"/> 1 – 18 GHz <input type="checkbox"/> 18 – 25 GHz <input type="checkbox"/> 18 – 40 GHz <input checked="" type="checkbox"/> other: see diagrams Scan-Mode <input type="checkbox"/> 6 dB EMI-Receiver Mode <input checked="" type="checkbox"/> 3 dB Spectrum analyzer Mode Detector Peak and Average RBW/VBW Left band-edge: 100kHz/300kHz Right band-edge: 1 MHz / 3 MHz Mode: Repetitive-Scan, max-hold Scan step 40kHz or 400 kHz Sweep-Time Coupled – calibrated display if CW signal otherwise adapted to EUT's individual duty-cycle		
General measurement procedures	Please see chapter "Test system set-up for radiated electric field measurements above 1 GHz" for general measurements procedures in anechoic chamber.		

5.5.4. Measurement Method

For uncritical results where a measurement resolution bandwidth of 1MHz can clearly show the compliance without influencing the results, a field strength measurement was performed to show compliance.

For critical results a Marker-Delta marker method was used for showing compliance to restricted bands. The method is according ANSI C63.10:2013, Chapter 6.10.6 “Marker-Delta method”

5.5.5. EUT settings

The EUT was instructed to send with maximum power (if adjustable) according to applicants instructions.

5.5.6. Results for FCC and ISED

Tests have been performed conducted and results up-scaled to radiated values.

Results for non-restricted bands - limits according to FCC §15.407 /RSS-247, Issue 2

Results for restricted bands near-by - limits accord. FCC §15.205 / §15.209

20MHz

Diagramm no.	Channel no.	Restricted band ?	Fundamental Value [dBuV/m]		Value at Band-Edge [dBm/MHz]		Limits [dBm/MHz]		Duty-Cycle Correction for AV-detector [dB]	Margin [dB]		Verdict	Remark:	
			Bandedge	BW	Peak -Value	Average -Value	Peak -Value	Average -Value		Peak	Average			
9.01_lay	36	yes	low	20	-52,518	-62,799	-27	-41,2	0	25,518	21,599	PASS		
9.01_sta	36	yes	low	20	-51,959	-62,062	-27	-41,2	0	24,959	20,862	PASS		
9.02_lay	64	yes	high	20	-52,817	-62,576	-27	-41,2	0	25,817	21,376	PASS		
9.02_sta	64	yes	high	20	-52,561	-62,323	-27	-41,2	0	25,561	21,123	PASS		
9.05_lay	100	yes	low	20	-52,845	-62,841	-27	-41,2	0	25,845	21,641	PASS		
9.05_sta	100	yes	low	20	-52,4	-62,453	-27	-41,2	0	25,4	21,253	PASS		
9.04_lay	140	no	high	20	-53,071	-62,301	-27	-41,2	0	26,071	21,101	PASS		
9.04_sta	140	no	high	20	-52,944	-62,397	-27	-41,2	0	25,944	21,197	PASS		
9.07_lay	149	no	low	20	Peak value -9,38 dBm/MHz within spectrum mask. See diagram								PASS	
9.07_sta	149	no	low	20	Peak value -7,00 dBm/MHz within spectrum mask. See diagram								PASS	
9.06_lay	165	no	high	20	Peak value -8,66 dBm/MHz within spectrum mask. See diagram								PASS	
9.06_sta	165	no	high	20	Peak value -8,53 dBm/MHz within spectrum mask. See diagram								PASS	

Remark : The EUT complies to the band edge requirement under provision that the power level is adjusted to those listed in the table above.

5.5.7. Results for restricted emissions in 5250-5350MHz band when TX operable in 5150-5250MHz band

Requirement Canada RSS-247, Issue 2, Chapter 6.2.1.2

See annex 1 for results and calculations

Diagram No.	Channel no.	Occupied Bandwidth	Channel power	Max. Power within band 5250 to 5350MHz (measured approx.. 1% of OBW)	Attenuation in regard to channel power
OBW_6Mbit_2 Channel_power_6Mbit_2 30.01_BE_Ch48_nmode	48	16.923MHz	-6.60dBm	-27.31dBm	>33.9 dBc

Verdict: Pass

5.5.8. Results for restricted emissions in 5150-5250MHz band when TX operable in 5250-5350MHz band

Requirement Canada RSS-247, Issue 2, Chapter 6.2.2.2 b

See annex 1 for results and calculations

9.03_BE_low_a-mode_ch052_laying

9.03_BE_low_a-mode_ch052_standing

Max. power density at 5250MHz point on operable channel 52, setup laying: -39.65dBm/MHz < 10dBm/MHz

Max. power density at 5250MHz point on operable channel 52, setup standing: -38.66dBm/MHz < 10dBm/MHz

Verdict: Pass

5.6. Measurement uncertainties

The reported uncertainties are calculated based on the standard uncertainty multiplied with the appropriate coverage factor **k**, such that a confidence level of approximately 95% is achieved.

For uncertainty determination, each component used in the concrete measurement set-up was taken in account and it's contribution to the overall uncertainty according it's statistical distribution calculated.

Following table shows expectable uncertainties for each measurement type performed.

RF-Measurement	Reference	Frequency range	Calculated uncertainty based on a confidence level of 95%						Remarks
Conducted emissions (U _{CISPR})	CISPR 16-2-1	9 kHz - 150 kHz	4.0 dB						-
		150 kHz - 30 MHz	3.6 dB						
Radiated emissions Enclosure	CISPR 16-2-3	30 MHz - 1 GHz	4.2 dB						E-Field
		1 GHz - 18 GHz	5.1 dB						
Disturbance power	CISPR 16-2-2	30 MHz - 300 MHz	-						-
Power Output radiated	-	30 MHz - 4 GHz	3.17 dB						Substitution method
Power Output conducted	-	Set-up No.	Cel-C1	Cel-C2	BT1	W1	W2	--	-
		9 kHz - 12.75 GHz	N/A	0.60	0.7	0.25	N/A	--	
		12.75 - 26.5GHz	N/A	0.82	--	N/A	N/A	--	
Conducted emissions on RF-port	-	9 kHz - 2.8 GHz	0.70	N/A	0.70	N/A	0.69	--	N/A - not applicable
		2.8 GHz - 12.75GHz	1.48	N/A	1.51	N/A	1.43	--	
		12.75 GHz - 18GHz	1.81	N/A	1.83	N/A	1.77	--	
		18 GHz - 26.5GHz	1.83	N/A	1.85	N/A	1.79	--	
Occupied bandwidth	-	9 kHz - 4 GHz	0.1272 ppm (Delta Marker)						Frequency error
			1.0 dB						Power
Emission bandwidth	-	9 kHz - 4 GHz	0.1272 ppm (Delta Marker)						Frequency error
			See above: 0.70 dB						Power
Frequency stability	-	9 kHz - 20 GHz	0.0636 ppm						-
Radiated emissions Enclosure	-	150 kHz - 30 MHz	5.0 dB						Magnetic field E-field Substitution
		30 MHz - 1 GHz	4.2 dB						
		1 GHz - 20 GHz	3.17 dB						

Table: measurement uncertainties, valid for conducted/radiated measurements

6. Abbreviations used in this report

The abbreviations	
ANSI	American National Standards Institute
AV . AVG. CAV	Average detector
EIRP	Equivalent isotropically radiated power. determined within a separate measurement
EGPRS	Enhanced General Packet Radio Service
EUT	Equipment Under Test
FCC	Federal Communications Commission. USA
IC	Industry Canada
n.a.	not applicable
Op-Mode	Operating mode of the equipment
PK	Peak
RBW	resolution bandwidth
RF	Radio frequency
RSS	Radio Standards Specification. Documents from Industry Canada
Rx	Receiver
TCH	Traffic channel
Tx	Transmitter
QP	Quasi peak detector
VBW	Video bandwidth
ERP	Effective radiated power

7. Accreditation details of CETECOM's laboratories and test sites

Ref.-No.	Accreditation Certificate	Valid for laboratory area or test site	Accreditation Body
-	D-PL-12047-01-01	All laboratories and test sites of CETECOM GmbH. Essen	DAkkS. Deutsche Akkreditierungsstelle GmbH
337 487 558 348 348	(MRA US-EU 0003)	Radiated Measurements 30 MHz to 1 GHz. 3 m / 10 m (OATS) Radiated Measurements 30 MHz to 1 GHz. 3 m (SAR) Radiated Measurements above 1 GHz. 3 m (FAR) Mains Ports Conducted Interference Measurements Telecommunication Ports Conducted Interference Measurment.	FCC. Federal Communications Commission Laboratory Division. USA
337 487 550 558	3462D-1 3462D-2 3462D-2 3462D-3	Radiated Measurements 30 MHz to 1 GHz. 3 m / 10 m (OATS) Radiated Measurements 30 MHz to 1 GHz. 3 m (SAR) Radiated Measurements 1 GHz to 6 GHz. 3 m (SAR) Radiated Measurements above 1 GHz. 3 m (FAR)	ISED. Industry Canada Certification and Engineering Bureau
487 550 348 348	R-2666 G-301 C-2914 T-1967	Radiated Measurements 30 MHz to 1 GHz. 3 m (SAR) Radiated Measurements 1 GHz to 6 GHz. 3 m (SAR) Mains Ports Conducted Interference Measurements Telecommunication Ports Conducted Interference Measurment.	VCCI. Voluntary Control Council for Interference by Information Technology Equipment. Japan

OATS = Open Area Test Site. SAR = Semi Anechoic Room. FAR = Fully Anechoic Room

8. Instruments and Ancillary

8.1. Used equipment “CTC”

The “Ref.-No” in the left column of the following tables allows the clear identification of the laboratory equipment.

8.1.1. Test software and firmware of equipment

Ref.-No.	Equipment	Type	Serial-No.	Version of Firmware or Software during the test
001	EMI Test Receiver	ESS	825132/017	Firm.= 1.21 , OTP=2.0, GRA=2.0
012	Signal Generator (EMS-cond.)	SMY 01	839069/027	Firm.= V 2.02
013	Power Meter (EMS cond.)	NRVD	839111/003	Firm.= V 1.51
017	Digital Radiocommunication Tester	CMD 60 M	844365/014	Firmware = V 3.52 .22.01.99, DECT = D2.87 13.01.99
119	RT Harmonics Analyzer dig. Flickermeter	B10	G60547	Firm.= V 3.1DHG
261	Thermal Power Sensor	NRV-Z55	825083/0008	EPROM-Datum 02.12.04, SE EE 1 B
262	Power Meter	NRV-S	825770/0010	Firm.= 2.6
263	Signal Generator	SMP 04	826190/0007	Firm.=3.21
295	Racal Digital Radio Test Set	6103	1572	UNIT Firmware= 4.04, SW-Main=4.04, SW-BBP=1.04, SW-DSP=1.02, Hardboot=1.02, Softboot=2.02
298	Univ. Radio Communication Tester	CMU 200	832221/091	R&S Test Firmware =3.53 /3.54 (current Testsoftw. f. all band used
323	Digital Radiocommunication Tester	CMD 55	825878/0034	Firm.= 3.52 .22.01.99
335	CTC-EMS-Conducted	System EMS Conducted	-	EMC 32 V 8.52
340	Digital Radiocommunication Tester	CMD 55	849709/037	Firm.= 3.52 .22.01.99
366	Ultra Compact Simulator	UCS 500 M4	V0531100594	Firm. UCS 500=001925/3.06a02, rc=ISMIEC 4.10
371	Bluetooth Tester	CBT32	100153	CBT V5.30+ SW-Option K55, K57
377	EMI Test Receiver	ESCS 30	100160	Firm.= 2.30, OTP= 02.01, GRA= 02.36
378	Broadband RF Field Monitor	RadiSense III	03D00013SNO-08	Firm.= V.03D13
389	Digital Multimeter	Keithley 2000	0583926	Firm. = A13 (Mainboard) A02 (Display)
392	Radio Communication Tester	MT8820A	6K00000788	Firm.= 4.50 #005, IPL=4.01#001,OS=4.02#001, GSM=4.41#013, W-CDMA= 4.54#004, scenario= 4.52#002
436	Univ. Radio Communication Tester	CMU 200	103083	R&S Test Firmware Base=5.14, Mess-Software= GSM:5.14 WCDMA:5.14 (current Testsoftw. F. all band
441	CTC-SAR-EMI Cable Loss	System EMI field (SAR)	-	EMC 32 Version 8.52
442	CTC-SAR-EMS	System EMS field (SAR)	-	EMC 32 Version 8.40
443	CTC-FAR-EMI-RSE	System CTC-FAR-EMI-RSE	-	Spuri 7.2.5 or EMC 32 Ver. 9.15.00
444	CTC-FAR-EMS field	System-EMS-Field (FAR)	-	EMC 32 Version 9.15.00
460	Univ. Radio Communication Tester	CMU 200	108901	R&S Test Firmware Base=5.14, GSM=5.14 WCDMA=5.14 (current Testsoftw.,f. all band to be used.
489	EMI Test Receiver	ESU40	1000-30	Firmware=4.43 SP3, Bios=V5.1-16-3, Spec. =01.00
491	ESD Simulator dito	ESD dito	dit0307022	V 2.30
524	Voltage Drop Simulator	VDS 200	0196-16	Software Nr: 000037 Version V4.20a01
526	Burst Generator	EFT 200 A	0496-06	Software Nr. 000034 Version V2.32
527	Micro Pulse Generator	MPG 200 B	0496-05	Software-Nr. 000030 Version V2.43
528	Load Dump Simulator	LD 200B	0496-06	Software-Nr. 000031 Version V2.35a01
546	Univ. Radio Communication Tester	CMU 200	106436	R&S Test Firmware Base=5.14, GSM=5.14 WCDMA=5.14 (current Testsoftw.,f. all band to be used
547	Univ. Radio Communication Tester	CMU 200	835390/014	R&S Test Firmware Base=V5.1403 (current Testsoftw., f. all band used, GSM = 5.14 WCDMA: = 5.14
584	Spectrum Analyzer	FSU 8	100248	2.82_SP3
597	Univ. Radio Communication Tester	CMU 200	100347	R&S Test Firmware Base=5.01, GSM=5.02 WCDMA= not installed, Mainboard= μP1=V.850
607	Signal Generator	SMR 20	832033/011	V1.25
620	EMI Test Receiver	ESU 26	100362	4.43_SP3
642	Wideband Radio Communication Tester	CMW 500	126089	Setup V03.26, Test programm component V03.02.20
670	Univ. Radio Communication Tester	CMU 200	106833	μP1 =V8.50, Firmware = V.20
689	Vector Signal Generator	SMU200	100970	02.20.360.142
692	Bluetooth Tester	CBT 32	100236	CBT V 5.40, FW: V.2.41 (FPGA Digital, V. 3.09 FPGA RF)

8.1.2. Single instruments and test systems

Ref.-No.	Equipment	Type	Serial-No.	Manufacturer	Interval of calibration	Remark	Cal due
001	EMI Test Receiver	ESS	825132/017	Rohde & Schwarz	12 M	-	16.05.2018
005	AC - LISN (50 Ohm/50µH, test site 1)	ESH2-Z5	861741/005	Rohde & Schwarz	12 M	-	15.05.2018
007	Single-Line V-Network (50 Ohm/5µH)	ESH3-Z6	892563/002	Rohde & Schwarz	12 M	-	17.05.2018
009	Power Meter (EMS-radiated)	NRV	863056/017	Rohde & Schwarz	24 M	-	15.05.2019
016	Line Impedance Simulating Network	Op. 24-D	B6366	Spitzenberger+Spies	36 M	-	30.05.2019
021	Loop Antenna (H-Field)	6502	9206-2770	EMCO	36 M	-	30.04.2018
030	Loop Antenna (H-field)	HFH-Z2	879604/026	Rohde & Schwarz	36 M	-	30.04.2018
033	RF-current probe (100kHz-30MHz)	ESH2-Z1	879581/18	Rohde & Schwarz	24 M	-	15.05.2019
057	relay-switch-unit (EMS system)	RSU	494440/002	Rohde & Schwarz	pre-m	1a	
060	power amplifier (DC-2kHz)	PAS 5000	B6363	Spitzenberger+Spies	-	3	
086	DC - power supply, 0 -10 A	LNG 50-10	-	Heinzinger Electronic	pre-m	2	
087	DC - power supply, 0 -5 A	EA-3013 S	-	Elektro Automatik	pre-m	2	
091	USB-LWL-Converter	OLS-1	007/2006	Ing. Büro Scheiba	-	4	
099	passive voltage probe	ESH2-Z3	299.7810.52	Rohde & Schwarz	36 M	-	30.04.2018
100	passive voltage probe	Probe TK 9416	without	Schwarzbeck	36 M	-	30.04.2018
110	USB-LWL-Converter	OLS-1	-	Ing. Büro Scheiba	-	4	
119	RT Harmonics Analyzer dig. Flickermeter	B10	G60547	BOCONSULT	36 M	-	30.05.2019
133	horn antenna 18 GHz (Meas 1)	3115	9012-3629	EMCO	36 M	1c	10.03.2020
134	horn antenna 18 GHz (Subst 2)	3115	9005-3414	EMCO	36 M	-	10.03.2020
136	adjustable dipole antenna (Dipole 1)	3121C-DB4	9105-0697	EMCO	36 M	-	30.04.2018
140	Signal Generator	SMHU	831314/006	Rohde & Schwarz	24 M	-	30.05.2018
248	attenuator	SMA 6dB 2W	-	Radiall	pre-m	2	
249	attenuator	SMA 10dB 10W	-	Radiall	pre-m	2	
252	attenuator	N 6dB 12W	-	Radiall	pre-m	2	
256	attenuator	SMA 3dB 2W	-	Radiall	pre-m	2	
257	hybrid	4031C	04491	Narda	pre-m	2	
260	hybrid coupler	4032C	11342	Narda	pre-m	2	
261	Thermal Power Sensor	NRV-Z55	825083/0008	Rohde & Schwarz	24 M	-	30.05.2018
262	Power Meter	NRV-S	825770/0010	Rohde & Schwarz	24 M	-	30.05.2018
263	Signal Generator	SMP 04	826190/0007	Rohde & Schwarz	36 M	-	30.05.2019
265	peak power sensor	NRV-Z33, Model 04	840414/009	Rohde & Schwarz	24 M	-	30.05.2018
266	Peak Power Sensor	NRV-Z31, Model 04	843383/016	Rohde & Schwarz	24 M	-	30.05.2018
267	notch filter GSM 850	WRCA 800/960-6EEK	9	Wainwright GmbH	pre-m	2	
270	termination	1418 N	BB6935	Weinschel	pre-m	2	
271	termination	1418 N	BE6384	Weinschel	pre-m	2	
272	attenuator (20 dB) 50 W	Model 47	BF6239	Weinschel	pre-m	2	
273	attenuator (10 dB) 100 W	Model 48	BF9229	Weinschel	pre-m	2	
274	attenuator (10 dB) 50 W	Model 47 (10 dB) 50 W	BG0321	Weinschel	pre-m	2	
275	DC-Block	Model 7003 (N)	C5129	Weinschel	pre-m	2	
276	DC-Block	Model 7006 (SMA)	C7061	Weinschel	pre-m	2	
279	power divider	1515 (SMA)	LH855	Weinschel	pre-m	2	
298	Univ. Radio Communication Tester	CMU 200	832221/091	Rohde & Schwarz	pre-m	3	
300	AC LISN (50 Ohm/50µH, 1-phase)	ESH3-Z5	892 239/020	Rohde & Schwarz	12 M	-	17.05.2018
301	attenuator (20 dB) 50W, 18GHz	47-20-33	AW0272	Lucas Weinschel	pre-m	2	
302	horn antenna 40 GHz (Meas 1)	BBHA9170	155	Schwarzbeck	36 M	-	14.03.2020
303	horn antenna 40 GHz (Subst 1)	BBHA9170	156	Schwarzbeck	36 M	-	20.03.2020
331	Climatic Test Chamber -40/+180 Grad	HC 4055	43146	Heraeus Vötsch	24 M	-	30.10.2018
341	Digital Multimeter	Fluke 112	81650455	Fluke	24 M	-	30.05.2018
342	Digital Multimeter	Voltcraft M-4660A	IB 255466	Voltcraft	24 M	-	17.05.2019
347	laboratory site	radio lab.	-	-	-	5	
348	laboratory site	EMI conducted	-	-	-	5	
354	DC - Power Supply 40A	NGPE 40/40	448	Rohde & Schwarz	pre-m	2	
355	Power Meter	URV 5	891310/027	Rohde & Schwarz	24 M	-	30.05.2018
357	power sensor	NRV-Z1	861761/002	Rohde & Schwarz	24 M	-	24.05.2019
371	Bluetooth Tester	CBT32	100153	R&S	36 M	-	30.05.2019
373	Single-Line V-Network (50 Ohm/5µH)	ESH3-Z6	100535	Rohde & Schwarz	12 M	-	17.05.2018
377	EMI Test Receiver	ESCS 30	100160	Rohde & Schwarz	12 M	-	15.05.2018
392	Radio Communication Tester	MT8820A	6K00000788	Anritsu	12 M	-	18.05.2018
405	Thermo-/Hygrometer	OPUS 10 THI	126.0604.0003.3.3.3.22	LUFFT Mess u. Regeltechnik	24 M	-	30.03.2019
431	Model 7405	Near-Field Probe Set	9305-2457	EMCO	-	4	
436	Univ. Radio Communication Tester	CMU 200	103083	Rohde & Schwarz	12 M	-	24.05.2018
439	UltraLog-Antenna	HL 562	100248	Rohde & Schwarz	36 M	-	10.03.2020
443	CTC-FAR-EMI-RSE	System CTC-FAR-EMI-RSE	-	ETS-Lindgren / CETECOM	12 M	5	30.09.2017
454	Oscilloscope	HM 205-3	9210 P 29661	Hameg	-	4	
456	DC-Power supply 0-5 A	EA 3013 S	207810	Elektro Automatik	pre-m	2	
459	DC -Power supply 0-5 A , 0-32 V	EA-PS 2032-50	910722	Elektro Automatik	pre-m	2	
463	Universal source	HP3245A	2831A03472	Agilent	-	4	
466	Digital Multimeter	Fluke 112	89210157	Fluke USA	24 M	-	30.05.2018

Ref.-No.	Equipment	Type	Serial-No.	Manufacturer	Interval of calibration	Remark	Cal due
467	Digital Multimeter	Fluke 112	89680306	Fluke USA	36 M	-	30.04.2018
468	Digital Multimeter	Fluke 112	90090455	Fluke USA	36 M	-	30.04.2018
477	ReRadiating GPS-System	AS-47	-	Automotive Cons. Fink	-	3	
480	power meter (Fula)	NRVS	838392/031	Rohde & Schwarz	24 M	-	16.05.2019
482	filter matrix	Filter matrix SAR 1	-	CETECOM (Bri)	-	1d	
487	System CTC NSA-Verification SAR-EMI	System EMI field (SAR) NSA	-	ETS Lindgren / CETECOM	24 M	-	31.09.2017
489	EMI Test Receiver	ESU40	1000-30	Rohde & Schwarz	12 M	-	18.05.2019
502	band reject filter	WRCG 1709/1786-1699/1796-	SN 9	Wainwright	pre-m	2	
503	band reject filter	WRCG 824/849-814/859-	SN 5	Wainwright	pre-m	2	
517	relais switch matrix	HF Relais Box Keithley	SE 04	Keithley	pre-m	2	
523	Digital Multimeter	L4411A	MY46000154	Agilent	24 M	-	18.05.2019
529	6 dB Broadband resistive power divider	Model 1515	LH 855	Weinschel	pre-m	2	
530	10 dB Broadband resistive power divider	R 416110000	LOT 9828	-	pre-m	2	
546	Univ. Radio Communication Tester	CMU 200	106436	R&S	12 M	-	30.03.2018
547	Univ. Radio Communication Tester	CMU 200	835390/014	Rohde & Schwarz	12 M	-	30.04.2017
549	Log.Per-Antenna	HL025	1000060	Rohde & Schwarz	36/12 M	-	31.07.2018
574	Biconilog Hybrid Antenna	BTA-L	980026L	Frankonia	36/12 M	-	31.03.2019
584	Spectrum Analyzer	FSU 8	100248	Rohde & Schwarz	pre-m	-	
597	Univ. Radio Communication Tester	CMU 200	100347	Rohde & Schwarz	pre-m	-	
600	power meter	NRVD (Reserve)	834501/018	Rohde & Schwarz	24 M	-	17.05.2019
601	medium-sensitivity diode sensor	NRV-Z5 (Reserve)	8435323/003	Rohde & Schwarz	24 M	-	15.05.2019
602	peak power sensor	NRV-Z32 (Reserve)	835080	Rohde & Schwarz	24 M	-	
611	DC power supply	E3632A	KR 75305854	Agilent	pre-m	2	
612	DC power supply	E3632A	MY 40001321	Agilent	pre-m	2	
613	Attenuator	R416120000 20dB 10W	Lot. 9828	Radiall	pre-m	2	
616	Digitalmultimeter	Fluke 177	88900339	Fluke	24 M	-	30.05.2018
617	Power Splitter/Combiner	ZFSC-2-2-S+	S F987001108	Mini Circuits	-	2	
618	Power Splitter/Combiner	50PD-634	600994	JFW Industries USA	-	2	
619	Power Splitter/Combiner	50PD-634	600995	JFW Industries, USA	-	3	
620	EMI Test Receiver	ESU 26	100362	Rohde-Schwarz	12 M	-	16.05.2018
621	Step Attenuator 0-139 dB	RSP	100017	Rohde & Schwarz	pre-m	2	
625	Generic Test Load USB	Generic Test Load USB	-	CETECOM	-	2	
627	data logger	OPUS 1	201.0999.9302.6.4.1.43	G. Luft GmbH	24 M	-	30.03.2019
634	Spectrum Analyzer	FSM (HF-Unit)	826188/010	Rohde & Schwarz	pre-m	2	
637	High Speed HDMI with Ethernet 1m	HDMI cable with Ethernet 1m	-	Kogilink	-	2	
638	HDMI Kabel with Ethernet 1,5 m flach	HDMI cable with Ethernet	-	Reichelt	-	2	
640	HDMI cable 2m rund	HDMI cable 2m rund	-	Reichelt	-	2	
641	HDMI cable with Ethernet	Certified HDMI cable with	-	PureLink	-	2	
642	Wideband Radio Communication Tester	CMW 500	126089	Rohde&Schwarz	12 M	-	24.05.2018
644	Amplifier	ZX60-2534M+	SN865701299	Mini-Circuits	-	-	
670	Univ. Radio Communication Tester	CMU 200	106833	Rohde & Schwarz	24 M	-	30.05.2018
671	DC-power supply 0-5 A	EA-3013S	-	Elektro Automatik	pre-m	2	
678	Power Meter	NRP	101638	Rohde&Schwarz	pre-m	-	
683	Spectrum Analyzer	FSU 26	200571	Rohde & Schwarz	12 M	-	17.05.2018
686	Field Analyzer	EHP-200A	160WX30702	Narda Safety Test Solutions	24 M	-	29.03.2019
687	Signal Generator	SMF 100A	102073	Rohde&Schwarz	12 M	-	17.05.2018
688	Pre Amp	JS-18004000-40-8P	1750117	Miteq	pre-m	-	
690	Spectrum Analyzer	FSU	100302/026	Rohde&Schwarz	12 M	-	16.05.2018
691	OSP120 Base Unit	OSP120	101183	Rohde & Schwarz	12 M	-	22.05.2018
692	Bluetooth Tester	CBT 32	100236	Rohde & Schwarz	36 M	-	29.05.2020
697	Power Splitter	ZN4PD-642W-S+	165001445	Mini-Circuits	-	2	
703	INNCO Antennen Mast	MA 4010-KT080-XPET-ZSS3	MA4170-KT100-XPET-	INNCO	pre-m	-	
704	INNCON Controller	CO 3000-4port	CO3000/933/38410516/L	INNCO Systems GmBh	pre-m	-	
711	Harmonic Mixer 90 GHz - 140GHz	RPG FS-Z140	101004	RPG	12 M	-	22.02.2018
712	Harmonic Mixer 75 GHz - 110GHz	FS-Z110	101468	Rohde & Schwarz	12 M	-	22.02.2018
713	Harmonic Mixer, 50 GHz - 75GHz	FS-Z75	101022	Rohde & Schwarz	12 M	-	22.05.2018
714	Signal Analyzer 67GHz	FSW67	104023	Rohde & Schwarz	24 M	-	03.03.2019
715	Harmonic Mixer, 140 GHz - 220GHz	FS-Z220	101009	RPG Radiometer Physics	12 M	-	03.08.2018
716	Harmonic Mixer 220 GHz to 325 GHz	FS-Z325	101005	RPG Radiometer Physics	12 M	-	13.02.2018
747	Spectrum Analyzer	FSU 26	200152	Rohde & Schwarz	12 M	-	18.05.2018
748	Pickett-Potter Horn Antenna	FH-PP 4060	010001	Radiometer Physics	-	-	
749	Pickett-potter Horn Antenna	FH-PP 60-90	010003	Radiometer Physics	-	-	
750	Pickett-Potter Horn Antenna	FH-PP 140-220	010011	Radiometer Physics	-	-	

8.1.3. Legend

Note / remarks		Calibrated during system calibration:
	1a	System CTC-SAR-EMS (Ref.-No. 442)
	1b	System-CTC-EMS-Conducted (Ref.-No. 335)
	1c	System CTC-FAR-EMI-RSE (Ref.-No . 443)
	1d	System CTC-SAR-EMI (Ref.-No . 441)
	1e	System CTC-OATS (EMI radiated) (Ref.-No. 337)
	1 f	System CTC-CTIA-OTA (Ref.-No . 420)
	1 g	System CTC-FAR-EMS (Ref.-No . 444)
	2	Calibration or equipment check immediately before measurement
	3	Regulatory maintained equipment for functional check or support purpose
	4	Ancillary equipment without calibration e.g. mechanical equipment or monitoring equipment
	5	Test System

Interval of calibration	12 M	12 month
	24 M	24 month
	36 M	36 month
	24/12 M	Calibration every 24 months, between this every 12 months internal validation
	36/12 M	Calibration every 36 months, between this every 12 months internal validation
	Pre-m	Check before starting the measurement
	-	Without calibration

9. Versions of test reports (change history)

Version	Applied changes	Date of release
--	Initial release	2018-07-20
--	--	--
--	--	--