



FCC TEST REPORT

according to

FCC Part 15, Subpart C (15.231) / ANSI C63.4: 2003

Applicant	: Data Light Technology Co., Ltd.
Address	: No. 63-5, Hsia-Kuei-Jou-Shan, Tan-shui Chen 251, Taipei Hsien, Taiwan, R.O.C.
Equipment	: Wireless control
Model No.	: HC-31D
FCC ID	: YBJ29316943
Trade Name	: Data Light

Laboratory Accreditation



- The test result refers exclusively to the test presented test model / sample.,
- Without written approval of **CerpPASS Technology Corp.** the test report shall not be reproduced except in full.



Contents

1.	Report of Measurements and Examinations.....	4
1.1.	List of Measurements and Examinations.....	4
2.	Test Configuration of Equipment under Test.....	5
2.1.	Feature of Equipment under Test.....	5
2.2.	Carrier Frequency of Channels.....	5
2.3.	Test Mode and Test Software.....	5
2.4.	Description of Test System.....	5
2.5.	Connection Diagram of Test System.....	6
2.6.	History of this test report.....	7
3.	Antenna Requirements.....	8
3.1.	Standard Applicable.....	8
3.2.	Antenna Construction and Directional Gain.....	8
4.	General Information of Test.....	8
5.	Test of Conducted Emission.....	9
5.1.	Test Limit.....	9
5.2.	Test Procedures.....	9
5.3.	Typical Test Setup.....	10
5.4.	Measurement Equipment.....	10
5.5.	Test Result and Data.....	11
5.6.	Test Photographs.....	13
6.	Test of Radiated Emission.....	14
6.1.	Test Limit.....	14
6.2.	Test Procedures.....	15
6.3.	Typical Test Setup Layout of Radiated Emission.....	16
6.4.	Measurement equipment.....	16
6.5.	Test Result and Data.....	17
6.6.	Test Photographs.....	33
7.	20dB Occupied Bandwidth Measurement.....	34
7.1.	Test Procedure.....	34
7.2.	Test Setup Layout.....	34
7.3.	Limits of Band Edges Measurement.....	34
7.4.	Measurement equipment.....	34
7.5.	Test Result.....	34
8.	Transmission Time Control.....	37
8.1.	Test Procedure.....	37
8.2.	Test Setup Layout.....	37
8.3.	Test Limit.....	37
8.4.	Measurement equipment.....	37
8.5.	Test Result.....	37
	Appendix A. Photographs of EUT.....	A1 ~ A3



CERTIFICATE OF COMPLIANCE

according to

FCC Part 15, Subpart C (15.231) / ANSI C63.4: 2003

Applicant : Data Light Technology Co., Ltd.
Address : No. 63-5, Hsia-Kuei-Jou-Shan, Tan-shui Chen 251,
Taipei Hsien, Taiwan, R.O.C.
Equipment : Wireless control
Model No. : HC-31D
FCC ID : YBJ29316943

I **HEREBY** CERTIFY THAT :

The measurements shown in this test report were made in accordance with the procedures given in **ANSI C63.4**. The equipment was **passed** the test performed according to **FCC Part 15, Subpart C (15.231) / ANSI C63.4: 2003**.

The test was carried out on Nov. 19, 2009 at **Cerpass Technology Corp.**

Signature

Anson Chou
EMC/RF B.U. Vice General Manager



1. Report of Measurements and Examinations

1.1. List of Measurements and Examinations

FCC Rule	Test Type	Result	Remark
15.203	Antenna Requirement	Pass	
15.207	Conducted Emission	Pass	6Vdc from batteries
15.209 15.231	Radiated Emission	Pass	Minimum Passing margin is -9.08 at 936.30 MHz
15.231	20dB Occupied Bandwidth Measurement	Pass	Meet the requirement of limit

Note: the information of measurement uncertainty is available upon the customer's request.



2. Test Configuration of Equipment under Test

2.1. Feature of Equipment under Test

- Voltage: DC5V
- Operating Frequency: 2.4GHz
- Current: 200mA
- Input port: 9 pin RS-232(Female)
- Transmitting Distance: 20M

2.2. Carrier Frequency of Channels

Channel	Frequency(MHz)	Channel	Frequency(MHz)
01	2405	07	2435
02	2410	08	2440
03	2415	09	2445
04	2420	10	2450
05	2425	11	2455
06	2430	---	---

2.3. Test Mode and Test Software

- a. During testing, the interface cables and equipment positions were varied according to ANSI C63.4.
- b. The complete test system included Remote Workstation, PC, Monitor, Mouse, Keyboard, Modem, Receiver, Adapter and EUT for EMI test.
- c. The EUT keeps to transmit and receive data by wireless.

2.4. Description of Test System

Device	Manufacturer	Model No.	Description
PC	IBM	IGV	Power Cable, Unshielding 1.8 m
Monitor	ViewSonic	P225f/G90fB	Data Cable, VGA Shielding 1.35 m Power Cable, Unshielding 1.8 m
Keyboard	IBM	KB-0225	Data Cable, PS2 Shielding 1.35 m
Mouse	IBM	MU29J	Data Cable, PS2 Shielding 1.85 m
Printer	hp	Desk Jet400	Data Cable, PRINT Unshielding 1.6 m Power Cable, Adapter Unshielding 1.8 m
Modem	ACEXX	DM-1414	Data Cable, RS232 Unshielding 1.35 m Power Cable, Adapter Unshielding 1.8 m
Adapter	DVE	DSA-0151A-05	Power Cable, shielding 1.8 m
Remote workstation			
Remote Dimmer	Avertronics	LCRD-11	N/A



2.5. Connection Diagram of Test System

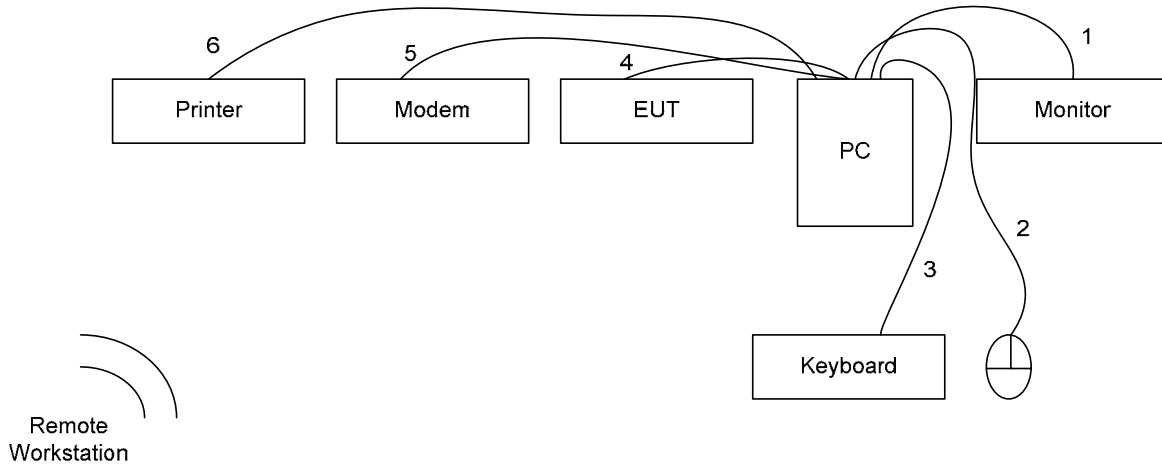

1. The VGA cable is connected from PC to the Monitor.
2. The PS/2 cable is connected from PC to the Mouse.
3. The PS/2 cable is connected from PC to the Keyboard.
4. The RS232 cable is connected from PC to the EUT.
5. The RS232 cable is connected from PC to the Modem.
6. The PRINT cable is connected from PC to the Printer.



2.6. History of this test report

ORIGINAL.

Additional attachment as following record:

Attachment No.	Issue Date	Description



3. Antenna Requirements

3.1. Standard Applicable

For intentional device, according to FCC 47 CFR Section 15.203, an intentional radiator shall be designed to ensure that no antenna other than that furnished by the responsible party shall be used with the device.

And according to FCC 47 CFR Section 15.247(b), if transmitting antennas of directional gain greater than 6dBi are used, the power shall be reduced by the amount in dB that the directional gain of the antenna exceeds 6dBi.

3.2. Antenna Construction and Directional Gain

Antenna type: Dipole Antenna

Antenna Gain: 1.88dBi

4. General Information of Test

Test Site :	CerpPASS Technology Corp. 2F-11, No. 3, Yuan Qu St., (Nankang Software Park), Taipei, Taiwan 115, R.O.C.
Test Site Location (OATS1-SD):	No. 7-2, Moshihkeng, Fongtian Village, Shihding Township, Taipei County, Taiwan, R.O.C.
FCC Registration Number :	TW1049, TW1056, 982971, 488071
IC Registration Number :	4934C-1, 4934D-1
Test Voltage:	DC 5V
Test in Compliance with:	FCC Part 15, Subpart C (15.231) / ANSI C63.4: 2001
Frequency Range Investigated:	Conducted Emission Test: from 150kHz to 30 MHz Radiated Emission Test: from 30 MHz to 25000 MHz
Modulation Type:	FSK
Test Distance:	The test distance of radiated emission above 1GHz from antenna to EUT is 3 M.



5. Test of Conducted Emission

5.1. Test Limit

Conducted Emissions were measured from 150 kHz to 30 MHz with a bandwidth of 9 KHz on the 120 VAC power and return leads of the EUT according to the methods defined in ANSI C63.4-2003 Section 3.1. The EUT was placed on a nonmetallic stand in a shielded room 0.8 meters above the ground plane as shown in section 2.2. The interface cables and equipment positioning were varied within limits of reasonable applications to determine the position produced maximum conducted emissions.

Frequency (MHz)	Quasi Peak (dB μ V)	Average (dB μ V)
0.15 – 0.5	66-56*	56-46*
0.5 – 5.0	56	46
5.0 – 30.0	60	50

*Decreases with the logarithm of the frequency.

5.2. Test Procedures

- a. The EUT was placed 0.4 meter from the conducting wall of the shielding room was kept at least 80 centimeters from any other grounded conducting surface.
- b. Connect EUT to the power mains through a line impedance stabilization network (LISN).
- c. All the support units are connecting to the other LISN.
- d. The LISN provides 50 ohm coupling impedance for the measuring instrument.
- e. The FCC states that a 50 ohm, 50 micro-Henry LISN should be used.
- f. Both sides of AC line were checked for maximum conducted interference.
- g. The frequency range from 150 kHz to 30 MHz was searched.
- h. Set the test-receiver system to Peak Detect Function and Specified Bandwidth with Maximum Hold Mode.



5.3. Typical Test Setup

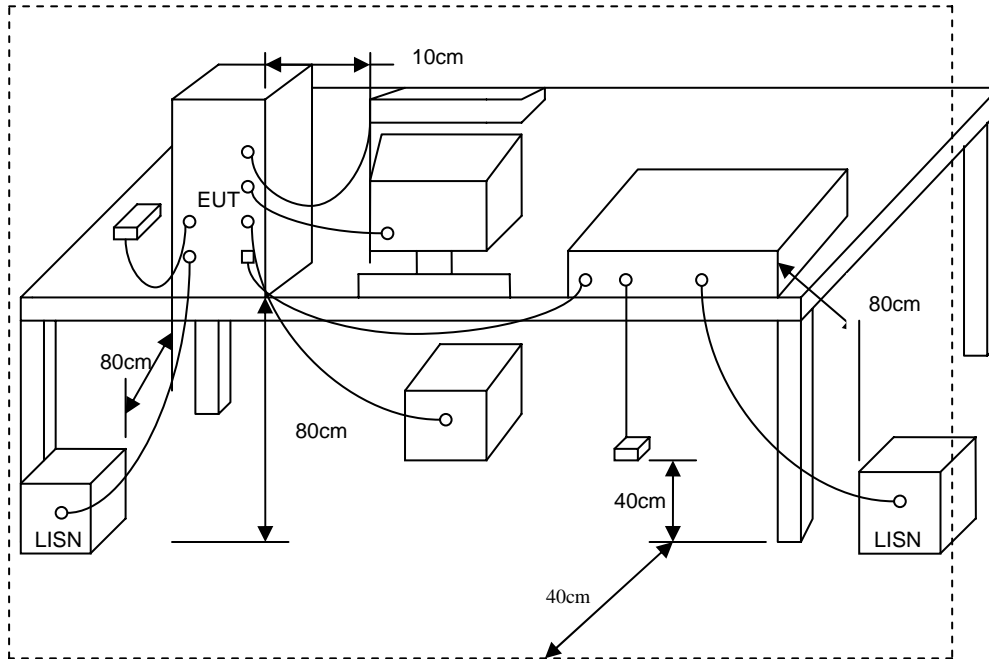

5.4. Measurement Equipment

Instrument/ Ancillary	Model No.	Manufacturer	Serial No.	Calibration Date	Valid Date.
EMI Receiver	R&S	ESCI	100443	2008/12/19	2009/12/18
LISN	NSLK 8127	Schwarzbeck	8127-516	2009/05/15	2010/05/14
LISN	ROLF HEINE	NNB-2/16Z	03/10058	2009/04/18	2010/04/17



5.5. Test Result and Data

Power	: DC 5V	Pol/Phase	: LINE
Test Mode	: FSK, CH01	Temperature	: 25 °C
Memo	:	Humidity	: 69 %

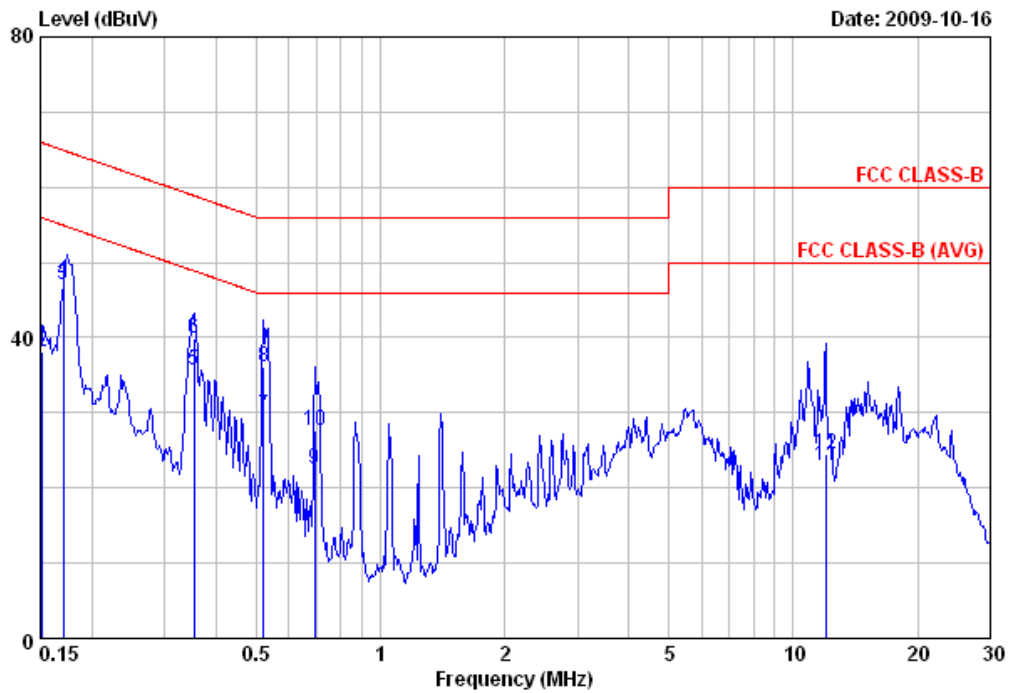

Item	Freq	Read Value	Factor	Result	Limit	Margin	Remark
	MHz	dBuV	dB/m	dBuV/m	dBuV/m	dB	
1	0.15	34.04	0.07	34.11	55.91	-21.80	Average
2	0.15	37.99	0.07	38.06	65.91	-27.85	QP
3	0.17	47.06	0.07	47.13	54.94	-7.81	Average
4	0.17	47.37	0.07	47.44	64.94	-17.50	QP
5	0.35	35.65	0.08	35.73	48.87	-13.14	Average
6	0.35	39.71	0.08	39.79	58.87	-19.08	QP
7	0.52	29.46	0.09	29.55	46.00	-16.45	Average
8	0.52	36.07	0.09	36.16	56.00	-19.84	QP
9	0.69	22.49	0.09	22.58	46.00	-23.42	Average
10	0.69	27.60	0.09	27.69	56.00	-28.31	QP
11	12.00	22.37	0.54	22.91	50.00	-27.09	Average
12	12.00	24.08	0.54	24.62	60.00	-35.38	QP

Notes:

1. Result = Read Value + Factor
2. Factor = LISN Factor + Cable Loss
3. According to technical experiences, all spurious emission of FSK mode at channel 1,6,11 are almost the same below 1GHz, so that the channel 1 was chosen as representative in final test.
4. The data is worse case.



Power	: DC 5V	Pol/Phase	: NEUTRAL
Test Mode	: FSK, CH01	Temperature	: 25 °C
Memo	:	Humidity	: 69 %

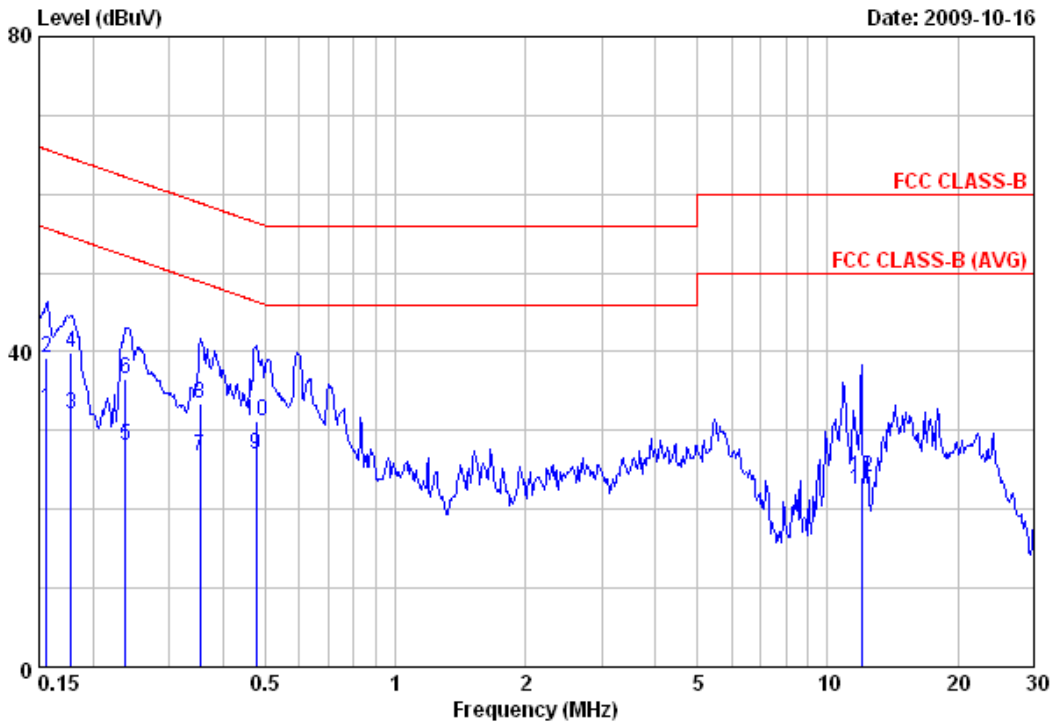

Item	Freq	Read Value	Factor	Result	Limit	Margin	Remark
	MHz	dBuV	dB/m	dBuV/m	dBuV/m	dB	
1	0.16	32.79	0.07	32.86	66.00	-33.14	Average
2	0.16	39.23	0.07	39.30	65.67	-26.37	QP
3	0.18	32.04	0.07	32.11	66.00	-33.89	Average
4	0.18	39.80	0.07	39.87	64.59	-24.72	QP
5	0.24	28.04	0.07	28.11	66.00	-37.89	Average
6	0.24	36.56	0.07	36.63	62.17	-25.54	QP
7	0.35	26.74	0.08	26.82	66.00	-39.18	Average
8	0.35	33.38	0.08	33.46	58.87	-25.41	QP
9	0.48	26.81	0.08	26.89	66.00	-39.11	Average
10	0.48	31.11	0.08	31.19	56.41	-25.22	QP
11	12.00	22.03	0.44	22.47	60.00	-37.53	Average
12	12.00	23.63	0.44	24.07	60.00	-35.93	QP

Notes:

1. Result = Read Value + Factor
2. Factor = LISN Factor + Cable Loss
3. According to technical experiences, all spurious emission of FSK mode at channel 1,6,11 are almost the same below 1GHz, so that the channel 1 was chosen as representative in final test.
4. The data is worse case.

Test engineer: Ben



6. Test of Radiated Emission

6.1. Test Limit

According to 15.231 the field strength of emissions from intentional radiators operated under these frequencies bands shall not exceed the following:

Frequency (MHz)	Field Strength of Fundamental		Field Strength of Spurious	
	$\mu\text{V}/\text{m}$	$\text{dB}\mu\text{V}/\text{m}$	$\mu\text{V}/\text{m}$	$\text{dB}\mu\text{V}/\text{m}$
40.66 ~ 40.70	2250	67.04	225	48.04
70 ~ 130	1250	61.94	125	41.94
130 ~ 174	1250 ~ 3750	61.94 ~ 71.48	125 ~ 375	41.94 ~ 51.48
174 ~ 260	3750	71.48	375	51.48
260 ~ 470	3750 ~ 12500	71.48 ~ 81.94	375 ~ 1250	51.48 ~ 61.94
Above 470	12500	81.94	1250	61.94

NOTE:

- Where F is the frequency in MHz, the formula for calculating the maximum permitted fundamental field strengths are as follows: for the band 130-174 MHz, $\mu\text{V}/\text{m}$ at 3 meters = $56.81818(F)-6136.3636$; for the band 260-470 MHz, $\mu\text{V}/\text{m}$ at 3 meters = $41.6667(F)-7083.3333$. The maximum permitted unwanted emission level is 20 dB below the maximum permitted fundamental level.
- The above field strength limits are specified at a distance of 3 meters. The tighter limits apply at the band edges.

Emissions radiated outside of the specified bands, shall be according to the general radiated limits in 15.209 as following:

Frequency (MHz)	Distance	Limit ($\mu\text{V}/\text{m}$)
0.09 ~ 0.490	300m	$2400/F(\text{kHz})$
0.490 ~ 1.705	30m	$24000/ F(\text{kHz})$
1.705 ~ 30	30m	30
30 ~ 88	3m	100
88 ~ 216	3m	150
216 ~ 960	3m	200
Above 960	3m	500

As shown in 15.35(b), for frequencies above 1000MHz, the field strength limits are based on average detector, however, the peak field strength of any emission shall not exceed the maximum permitted average limits, specified above by more than 20dB under any condition of modulation.



6.2. Test Procedures

- a. The EUT was placed on a rotatable table top 0.8 meter above ground.
- b. The EUT was set 3 meters from the interference receiving antenna which was mounted on the top of a variable height antenna tower.
- c. The table was rotated 360 degrees to determine the position of the highest radiation.
- d. The antenna is a broadband antenna and its height is varied between one meter and four meters above ground to find the maximum value of the field strength both horizontal polarization and vertical polarization of the antenna are set to make the measurement.
- e. For each suspected emission the EUT was arranged to its worst case and then tune the antenna tower (from 1 M to 4 M) and turn table (from 0 degree to 360 degrees) to find the maximum reading.
- f. Set the test-receiver system to Peak or CISPR quasi-peak Detect Function and specified bandwidth with Maximum Hold Mode.
- g. If the emission level of the EUT in peak mode was 3 dB lower than the limit specified, then testing will be stopped and peak values of EUT will be reported, otherwise, the emissions which do not have 3 dB margin will be repeated one by one using the quasi-peak method and reported.
- h. For testing above 1GHz, the emission level of the EUT in peak mode was 20dB lower than average limit (that means the emission level in peak mode also complies with the limit in average mode), then testing will be stopped and peak values of EUT will be reported, otherwise, the emissions will be measured in average mode again and reported.
- i. "Cone of radiation" has been considered to be 3dB beamwidth of the measurement antenna.

NOTE:

1. The resolution bandwidth and video bandwidth of test receiver/spectrum analyzer is 120kHz for Peak detection (PK) and Quasi-peak detection (QP) at frequency below 1GHz.
2. The resolution bandwidth and video bandwidth of test receiver/spectrum analyzer is 1 MHz for Peak detection at frequency above 1GHz.
3. The resolution bandwidth of test receiver/spectrum analyzer is 1 MHz and the video bandwidth is 10 Hz for Average detection (AV) at frequency above 1GHz.



6.3. Typical Test Setup Layout of Radiated Emission

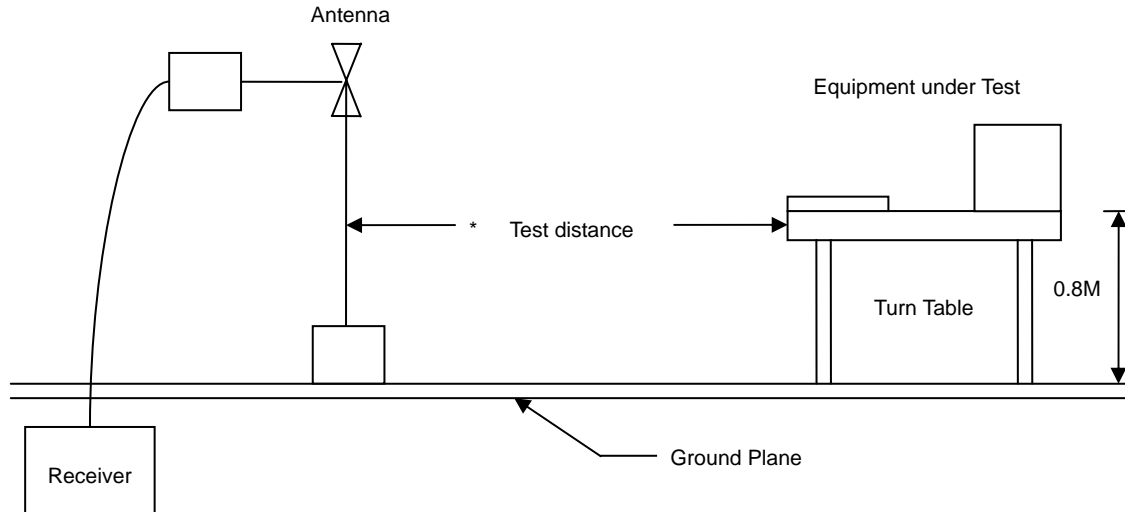

6.4. Measurement equipment

Instrument/Ancillary	Manufacturer	Model No.	Serial No.	Calibration Date	Valid Date
Bilog Antenna	Schaffner	CBL6112B	2840	2009/05/14	2010/05/13
Amplifier	Agilent	8447D	2944A10593	2009/05/21	2010/05/20
EMI Receiver	R&S	ESCI	100443	2008/12/19	2009/12/18
AC Power Converter	APC	AFC-11005	F103120008	N/A	N/A



6.5. Test Result and Data

6.5.1. Test Result of Fundamental Emission

Power	: DC 5V	Pol/Phase	: VERTICAL
Test Mode	: Transmit/ Receive	Temperature	: 26 °C
Operation Channel	: 1	Humidity	: 57 %
Modulation Type	: FSK	Atmospheric Pressure	: 1021 hPa

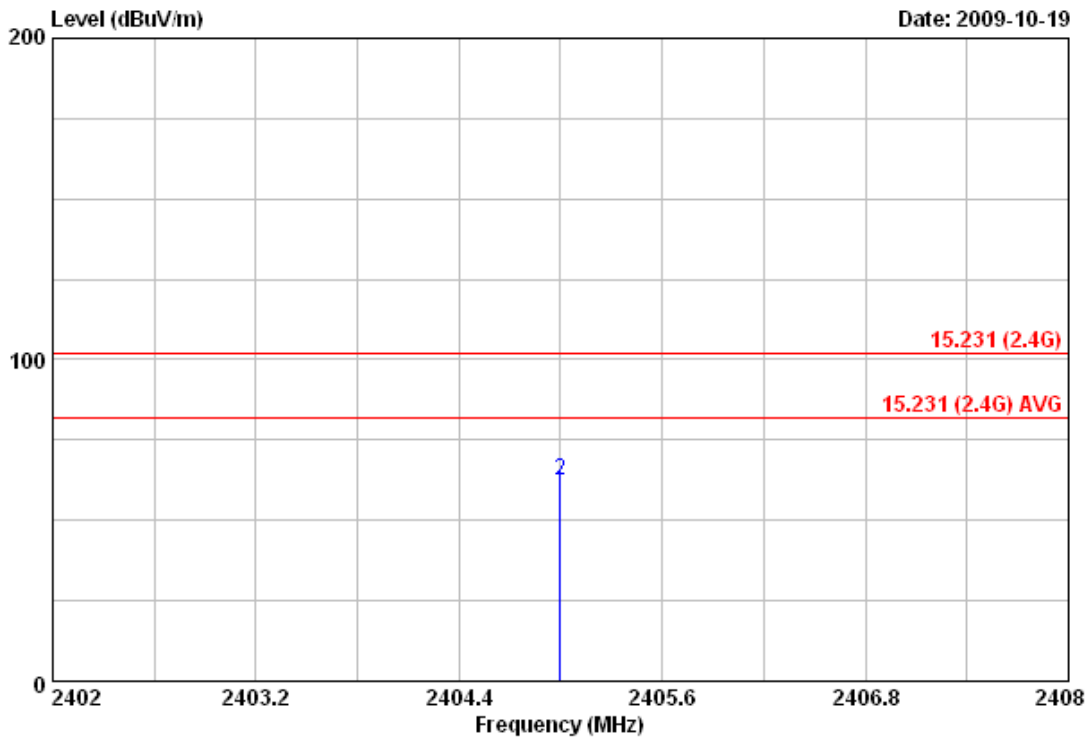

Item	Freq	Read Value	Factor	Result	Limit	Margin	Remark	Ant Pos	Tab Pos
	MHz	dBuV	dB/m	dBuV/m	dBuV/m	dB		cm	Deg
1	2405.00	59.84	-0.60	59.24	81.90	-22.66	Average	100	0
2	2405.00	63.20	-0.60	62.60	101.90	-39.30	Peak	100	0

Notes:

1. Result = Read Value + Factor
2. Factor = Antenna Factor + Cable Loss - Amplifier
3. The resolution bandwidth of test receiver/spectrum analyzer is 120KHz and video bandwidth is 300kHz for Peak detection and Quasi-peak detection at frequency below 1GHz.
4. The resolution bandwidth of test receiver/spectrum analyzer is 1MHz and video bandwidth is 3MHz for Peak detection at frequency above 1GHz.
5. The resolution bandwidth of test receiver/spectrum analyzer is 1MHz and video bandwidth is 10Hz for Average detection at frequency above 1GHz.
6. The other emissions is too low to be measured.
7. The data is worse case.



Power	: DC 5V	Pol/Phase	: HORIZONTAL
Test Mode	: Transmit/ Receive	Temperature	: 26 °C
Operation Channel	: 1	Humidity	: 57 %
Modulation Type	: FSK	Atmospheric Pressure	: 1021 hPa

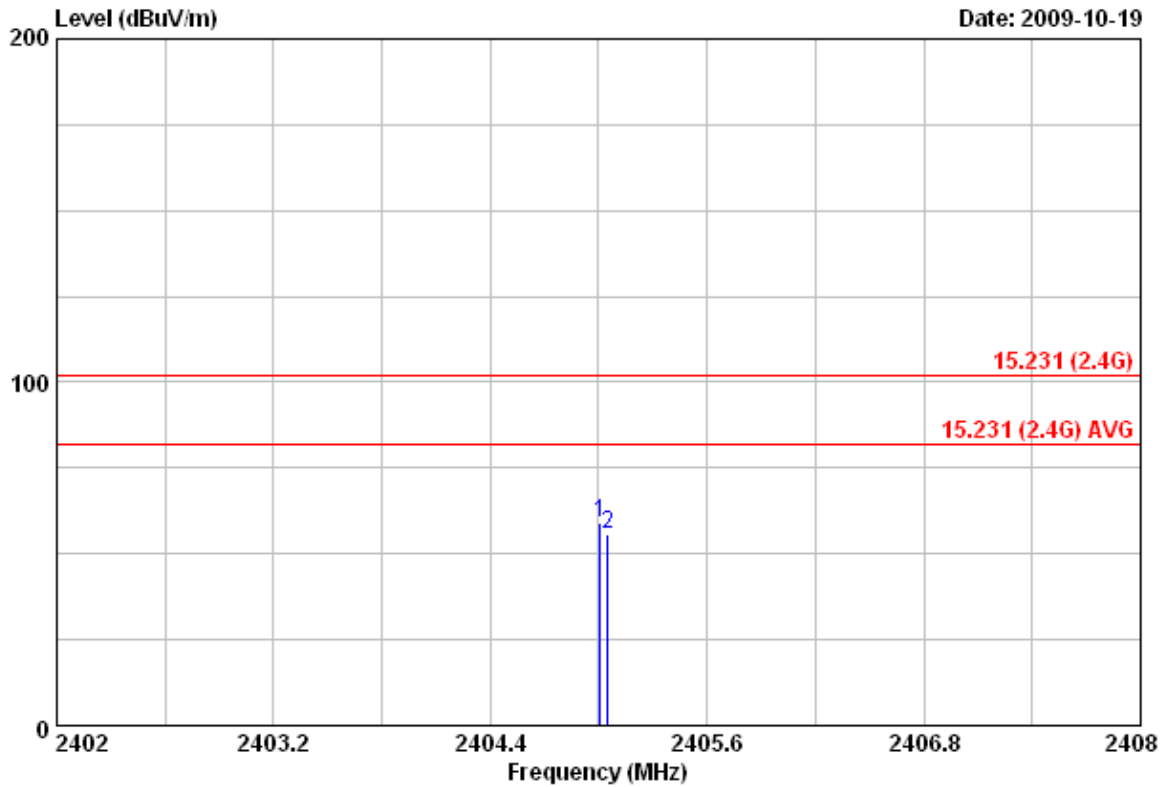

Item	Freq	Read Value	Factor	Result	Limit	Margin	Remark	Ant Pos	Tab Pos
	MHz	dBuV	dB/m	dBuV/m	dBuV/m	dB		cm	Deg
1	2405.01	59.67	-0.60	59.07	101.90	-42.83	Peak	100	0
2	2405.05	56.30	-0.60	55.70	81.90	-26.20	Average	100	0

Notes:

1. Result = Read Value + Factor
2. Factor = Antenna Factor + Cable Loss - Amplifier
3. The resolution bandwidth of test receiver/spectrum analyzer is 120KHz and video bandwidth is 300kHz for Peak detection and Quasi-peak detection at frequency below 1GHz.
4. The resolution bandwidth of test receiver/spectrum analyzer is 1MHz and video bandwidth is 3MHz for Peak detection at frequency above 1GHz.
5. The resolution bandwidth of test receiver/spectrum analyzer is 1MHz and video bandwidth is 10Hz for Average detection at frequency above 1GHz.
6. The other emissions is too low to be measured.
7. The data is worse case.



Power	: DC 5V	Pol/Phase	: VERTICAL
Test Mode	: Transmit/ Receive	Temperature	: 25 °C
Operation Channel	: 6	Humidity	: 57 %
Modulation Type	: FSK	Atmospheric Pressure	: 1021 hPa

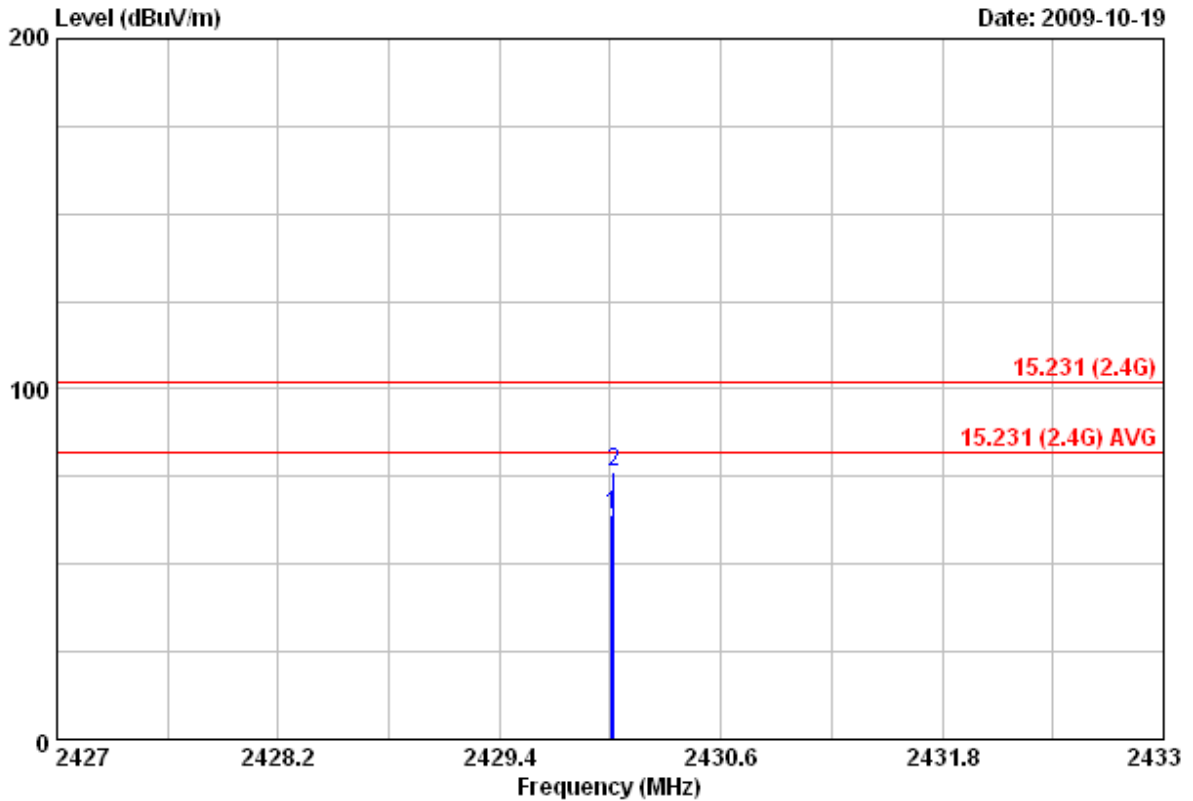

Item	Freq	Read Value	Factor	Result	Limit	Margin	Remark	Ant Pos	Tab Pos
	MHz	dBuV	dB/m	dBuV/m	dBuV/m	dB		cm	Deg
1	2430.01	64.59	-0.49	64.10	81.90	-17.80	Average	100	0
2	2430.02	76.73	-0.49	76.24	101.90	-25.66	Peak	100	0

Notes:

1. Result = Read Value + Factor
2. Factor = Antenna Factor + Cable Loss - Amplifier
3. The resolution bandwidth of test receiver/spectrum analyzer is 120KHz and video bandwidth is 300kHz for Peak detection and Quasi-peak detection at frequency below 1GHz.
4. The resolution bandwidth of test receiver/spectrum analyzer is 1MHz and video bandwidth is 3MHz for Peak detection at frequency above 1GHz.
5. The resolution bandwidth of test receiver/spectrum analyzer is 1MHz and video bandwidth is 10Hz for Average detection at frequency above 1GHz.
6. The other emissions is too low to be measured.
7. The data is worse case.



Power	: DC 5V	Pol/Phase	: HORIZONTAL
Test Mode	: Transmit/ Receive	Temperature	: 26 °C
Operation Channel	: 6	Humidity	: 57 %
Modulation Type	: FSK	Atmospheric Pressure	: 1021 hPa

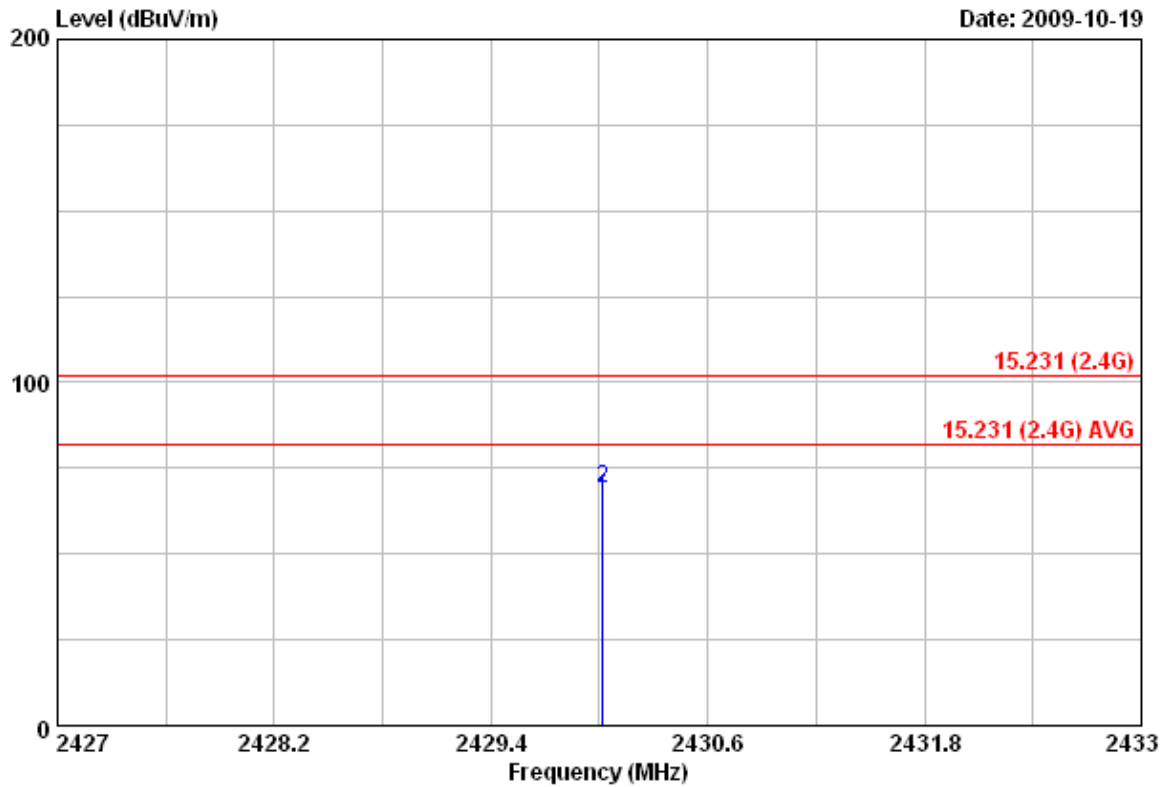

Item	Freq	Read Value	Factor	Result	Limit	Margin	Remark	Ant Pos	Tab Pos
	MHz	dBuV	dB/m	dBuV/m	dBuV/m	dB		cm	Deg
1	2430.02	66.87	-0.49	66.38	81.90	-15.52	Average	100	0
2	2430.02	69.59	-0.49	69.10	101.90	-32.80	Peak	100	0

Notes:

1. Result = Read Value + Factor
2. Factor = Antenna Factor + Cable Loss - Amplifier
3. The resolution bandwidth of test receiver/spectrum analyzer is 120KHz and video bandwidth is 300kHz for Peak detection and Quasi-peak detection at frequency below 1GHz.
4. The resolution bandwidth of test receiver/spectrum analyzer is 1MHz and video bandwidth is 3MHz for Peak detection at frequency above 1GHz.
5. The resolution bandwidth of test receiver/spectrum analyzer is 1MHz and video bandwidth is 10Hz for Average detection at frequency above 1GHz.
6. The other emissions is too low to be measured.
7. The data is worse case.



Power	: DC 5V	Pol/Phase	: VERTICAL
Test Mode	: Transmit/ Receive	Temperature	: 26 °C
Operation Channel	: 11	Humidity	: 57 %
Modulation Type	: FSK	Atmospheric Pressure	: 1021 hPa

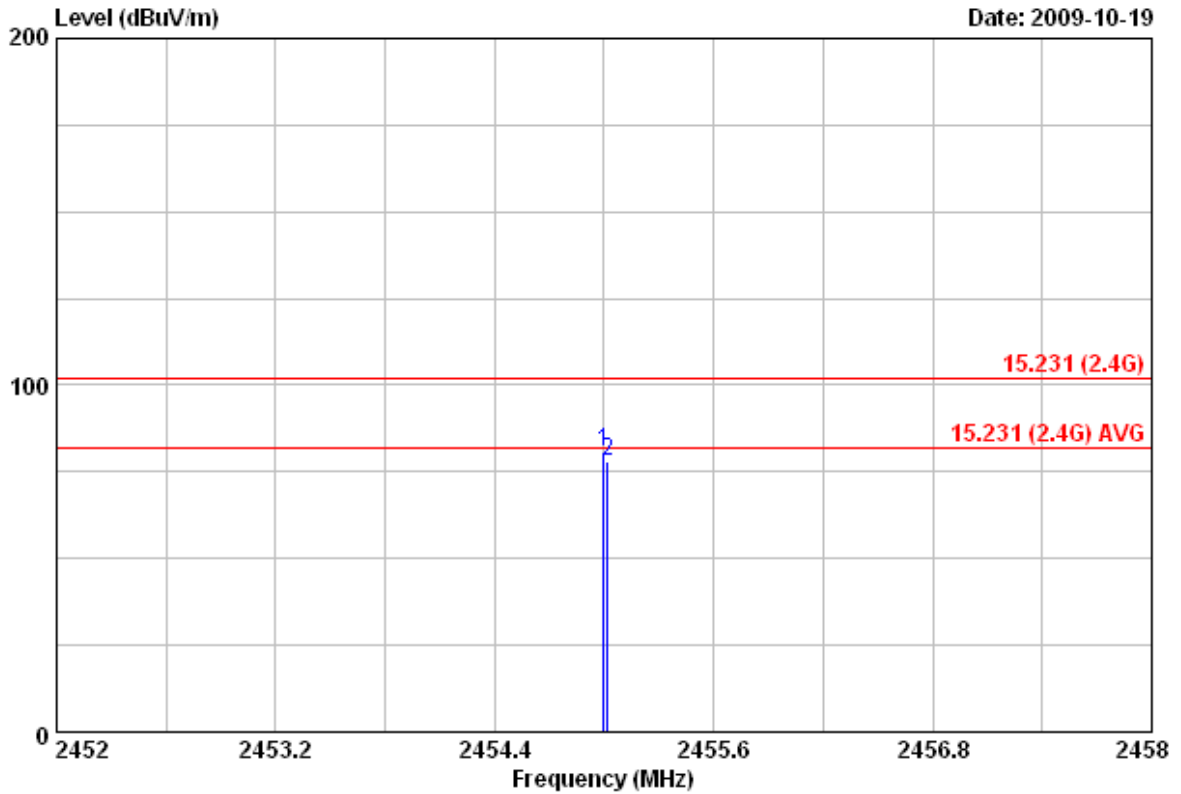

Item	Freq	Read Value	Factor	Result	Limit	Margin	Remark	Ant Pos	Tab Pos
	MHz	dBuV	dB/m	dBuV/m	dBuV/m	dB		cm	Deg
1	2455.00	81.09	-0.39	80.70	101.90	-21.20	Peak	100	0
2	2455.02	78.13	-0.39	77.74	81.90	-4.16	Average	100	0

Notes:

1. Result = Read Value + Factor
2. Factor = Antenna Factor + Cable Loss - Amplifier
3. The resolution bandwidth of test receiver/spectrum analyzer is 120KHz and video bandwidth is 300kHz for Peak detection and Quasi-peak detection at frequency below 1GHz.
4. The resolution bandwidth of test receiver/spectrum analyzer is 1MHz and video bandwidth is 3MHz for Peak detection at frequency above 1GHz.
5. The resolution bandwidth of test receiver/spectrum analyzer is 1MHz and video bandwidth is 10Hz for Average detection at frequency above 1GHz.
6. The other emissions is too low to be measured.
7. The data is worse case.



Power	: DC 5V	Pol/Phase	: HORIZONTAL
Test Mode	: Transmit/ Receive	Temperature	: 25 °C
Operation Channel	: 11	Humidity	: 57 %
Modulation Type	: FSK	Atmospheric Pressure	: 1021 hPa

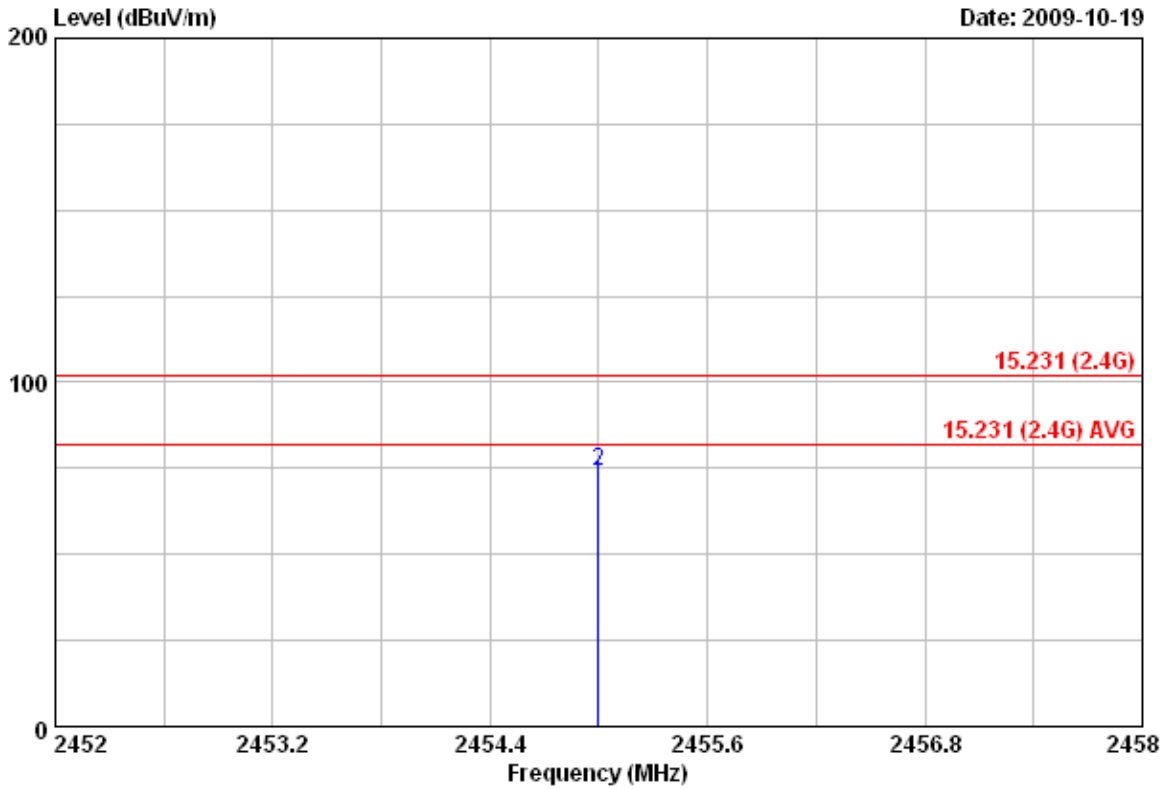

Item	Freq	Read Value	Factor	Result	Limit	Margin	Remark	Ant Pos	Tab Pos
	MHz	dBuV	dB/m	dBuV/m	dBuV/m	dB		cm	Deg
1	2455.00	71.23	-0.39	70.84	81.90	-11.06	Average	100	0
2	2455.00	74.74	-0.39	74.35	101.90	-27.55	Peak	100	0

Notes:

1. Result = Read Value + Factor
2. Factor = Antenna Factor + Cable Loss - Amplifier
3. The resolution bandwidth of test receiver/spectrum analyzer is 120KHz and video bandwidth is 300kHz for Peak detection and Quasi-peak detection at frequency below 1GHz.
4. The resolution bandwidth of test receiver/spectrum analyzer is 1MHz and video bandwidth is 3MHz for Peak detection at frequency above 1GHz.
5. The resolution bandwidth of test receiver/spectrum analyzer is 1MHz and video bandwidth is 10Hz for Average detection at frequency above 1GHz.
6. The other emissions is too low to be measured.
7. The data is worse case.



6.5.2. Test Result of Unwanted Spurious emission

Power	: DC 5V	Pol/Phase	: VERTICAL
Test Mode	: Transmit/ Receive	Temperature	: 26 °C
Operation Channel	: 1	Humidity	: 57 %
Modulation Type	: FSK	Atmospheric Pressure	: 1021 hPa

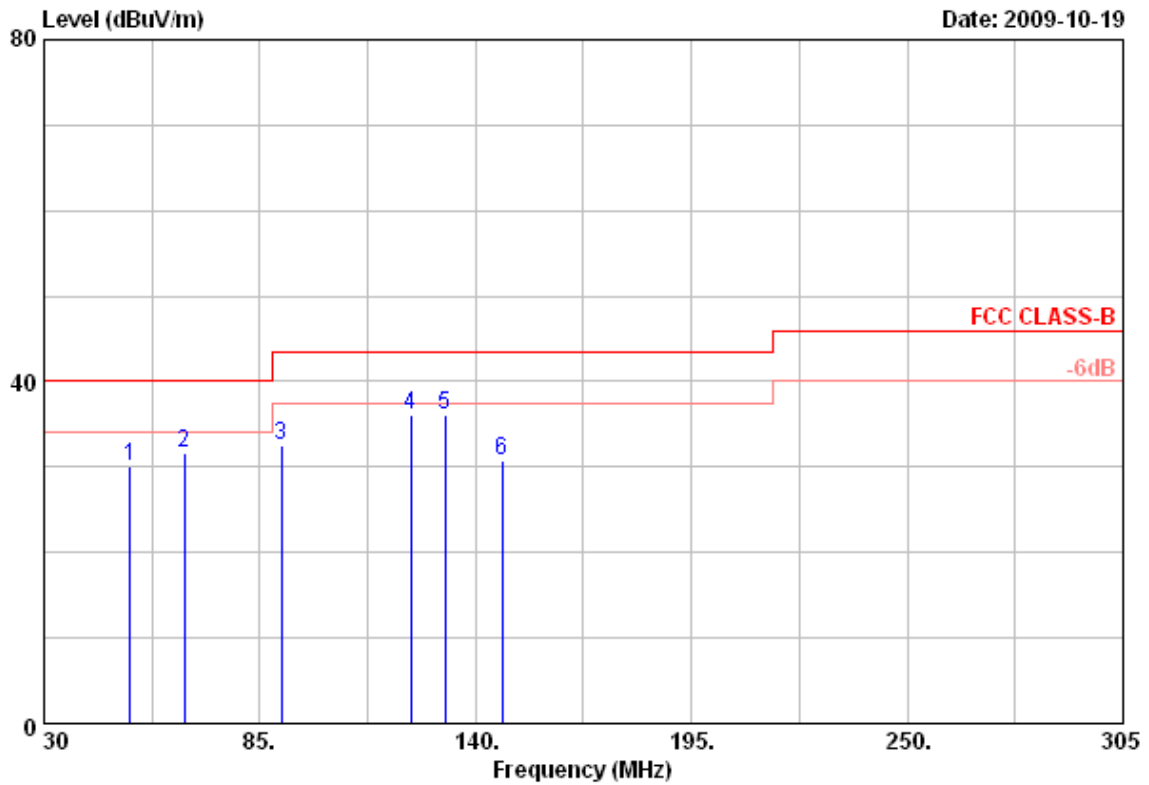

Item	Freq MHz	Read Value dBUV	Factor dB/m	Result dBUV/m	Limit dBUV/m	Margin dB	Remark	Ant Pos cm	Tab Pos Deg
1	52.00	41.21	-11.21	30.00	40.00	-10.00	Peak	100	360
2	65.75	45.89	-14.18	31.71	40.00	-8.29	Peak	100	360
3	90.50	45.10	-12.54	32.56	43.50	-10.94	Peak	100	360
4	123.50	45.79	-9.65	36.14	43.50	-7.36	Peak	100	360
5	132.30	45.45	-9.29	36.16	43.50	-7.34	Peak	100	360
6	146.88	41.89	-11.21	30.68	43.50	-12.82	Peak	100	360

Notes:

1. Result = Read Value + Factor
2. Factor = Antenna Factor + Cable Loss - Amplifier
3. The resolution bandwidth of test receiver/spectrum analyzer is 120KHz and video bandwidth is 300kHz for Peak detection and Quasi-peak detection at frequency below 1GHz.
4. According to technical experiences, all spurious emission of FSK mode at channel 1, 6, 11 are almost the same below 1GHz, so that the channel 1 was chosen as representative in final test.
5. The data is worse case.



Power	: DC 5V	Pol/Phase	: VERTICAL
Test Mode	: Transmit/ Receive	Temperature	: 26 °C
Operation Channel	: 1	Humidity	: 57 %
Modulation Type	: FSK	Atmospheric Pressure	: 1021 hPa

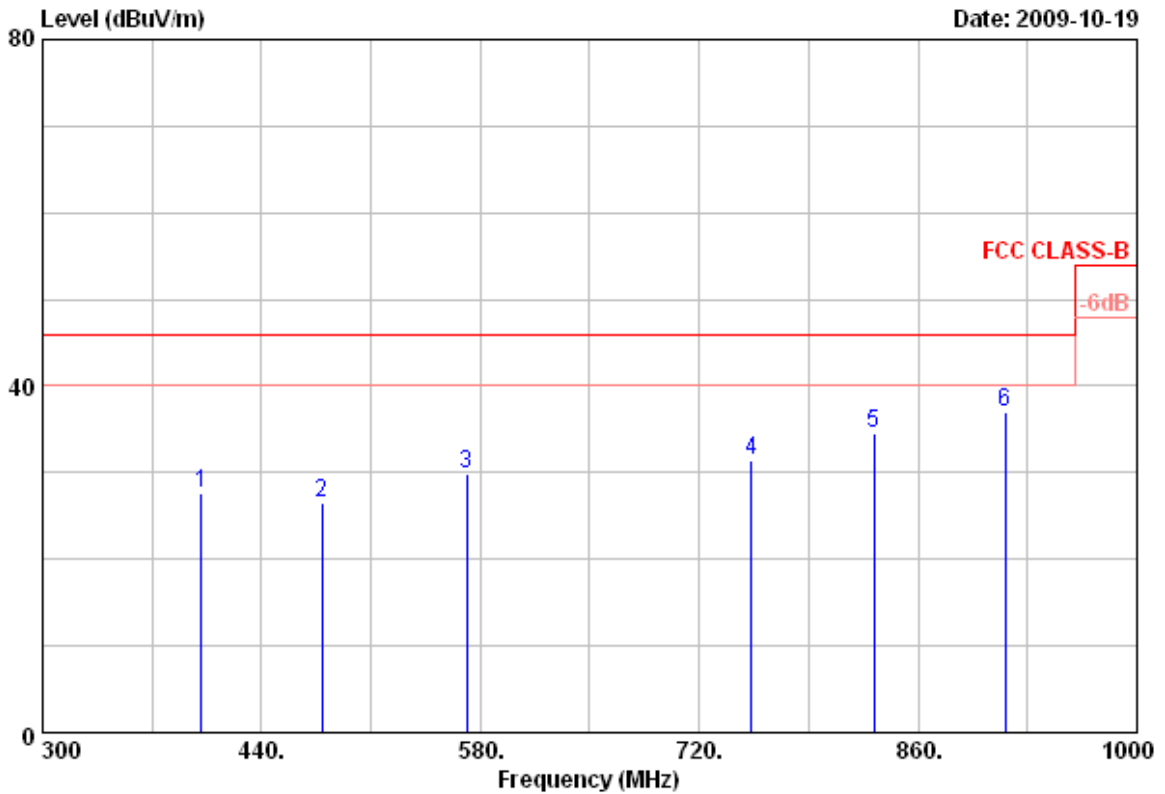

Item	Freq	Read Value	Factor	Result	Limit	Margin	Remark	Ant Pos	Tab Pos
	MHz	dBuV	dB/m	dBuV/m	dBuV/m	dB		cm	Deg
1	401.50	34.38	-6.81	27.57	46.00	-18.43	Peak	100	0
2	478.50	34.76	-8.20	26.56	46.00	-19.44	Peak	100	0
3	571.60	32.96	-3.10	29.86	46.00	-16.14	Peak	100	0
4	753.60	32.77	-1.34	31.43	46.00	-14.57	Peak	100	0
5	832.00	33.84	0.64	34.48	46.00	-11.52	Peak	100	0
6	916.00	32.91	3.99	36.90	46.00	-9.10	Peak	100	0

Notes:

1. Result = Read Value + Factor
2. Factor = Antenna Factor + Cable Loss - Amplifier
3. The resolution bandwidth of test receiver/spectrum analyzer is 120KHz and video bandwidth is 300kHz for Peak detection and Quasi-peak detection at frequency below 1GHz.
4. According to technical experiences, all spurious emission of FSK mode at channel 1,6,11 are almost the same below 1GHz, so that the channel 1 was chosen as representative in final test.
5. The data is worse case.



Power	: DC 5V	Pol/Phase	: HORIZONTAL
Test Mode	: Transmit/ Receive	Temperature	: 26 °C
Operation Channel	: 1	Humidity	: 57 %
Modulation Type	: FSK	Atmospheric Pressure	: 1021 hPa

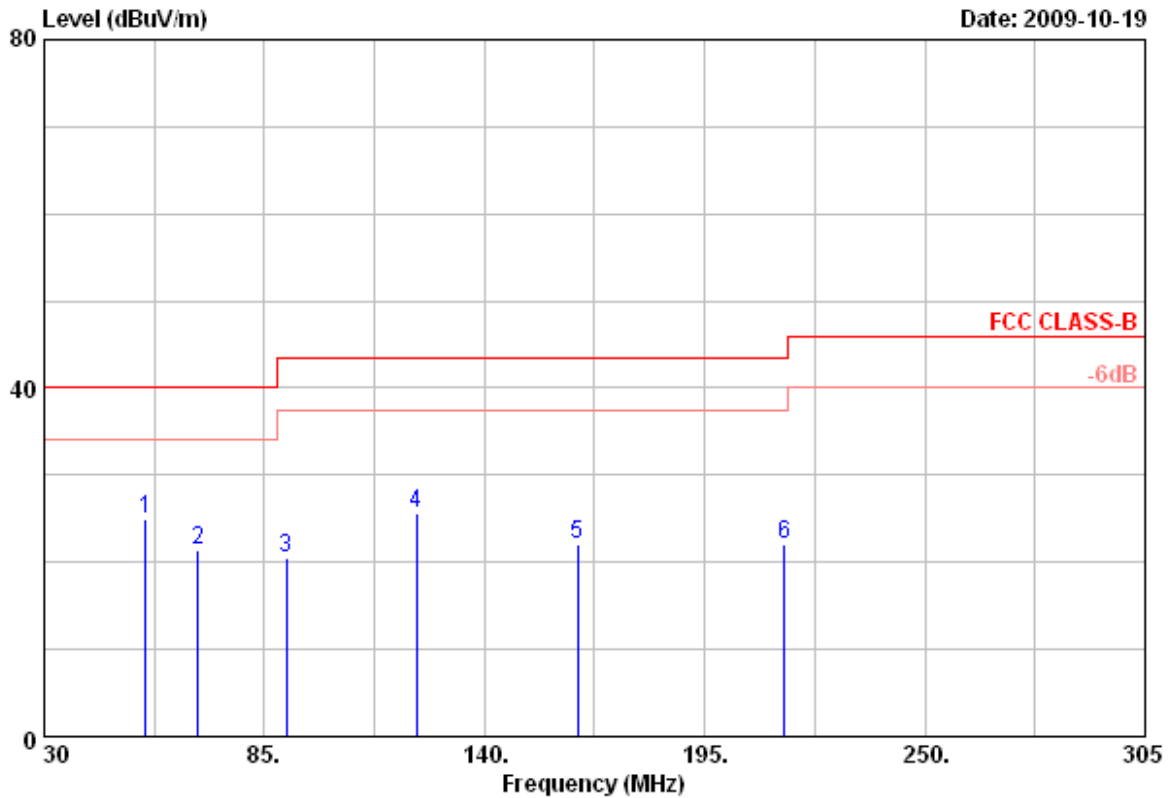

Item	Freq	Read Value	Factor	Result	Limit	Margin	Remark	Ant Pos	Tab Pos
	MHz	dBuV	dB/m	dBuV/m	dBuV/m	dB		cm	Deg
1	55.30	41.75	-16.82	24.93	40.00	-15.07	Peak	100	360
2	68.50	42.62	-21.23	21.39	40.00	-18.61	Peak	100	360
3	90.50	40.23	-19.79	20.44	43.50	-23.06	Peak	100	360
4	122.95	42.44	-16.85	25.59	43.50	-17.91	Peak	100	360
5	163.38	38.75	-16.70	22.05	43.50	-21.45	Peak	100	360
6	214.80	38.59	-16.59	22.00	43.50	-21.50	Peak	100	360

Notes:

1. Result = Read Value + Factor
2. Factor = Antenna Factor + Cable Loss - Amplifier
3. The resolution bandwidth of test receiver/spectrum analyzer is 120KHz and video bandwidth is 300kHz for Peak detection and Quasi-peak detection at frequency below 1GHz.
4. According to technical experiences, all spurious emission of FSK mode at channel 1,6,11 are almost the same below 1GHz, so that the channel 1 was chosen as representative in final test.
5. The data is worse case.



Power	: DC 5V	Pol/Phase	: HORIZONTAL
Test Mode	: Transmit/ Receive	Temperature	: 26 °C
Operation Channel	: 1	Humidity	: 57 %
Modulation Type	: FSK	Atmospheric Pressure	: 1021 hPa

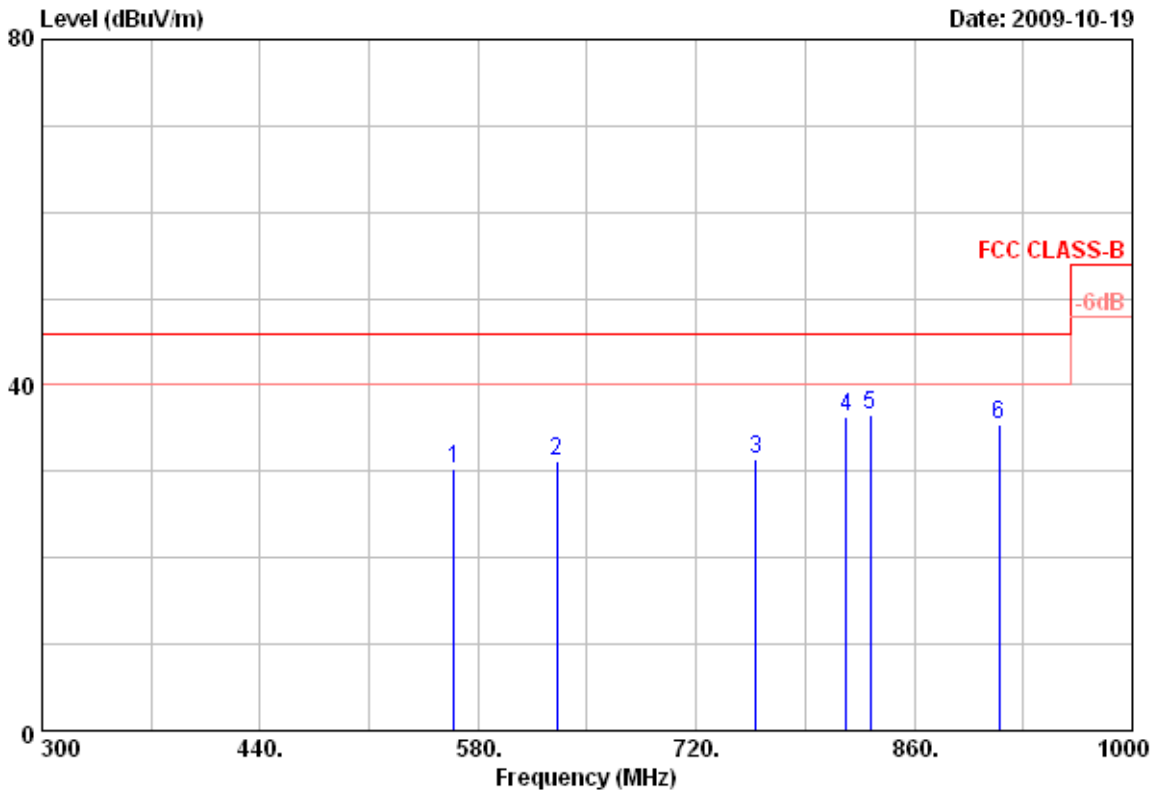

Item	Freq	Read Value	Factor	Result	Limit	Margin	Remark	Ant Pos	Tab Pos
	MHz	dBuV	dB/m	dBuV/m	dBuV/m	dB		cm	Deg
1	564.60	32.03	-1.64	30.39	46.00	-15.61	Peak	100	0
2	630.40	32.30	-1.19	31.11	46.00	-14.89	Peak	100	0
3	758.50	32.57	-1.10	31.47	46.00	-14.53	Peak	100	0
4	816.60	35.89	0.47	36.36	46.00	-9.64	Peak	100	0
5	832.00	34.86	1.76	36.62	46.00	-9.38	Peak	100	0
6	914.60	33.03	2.30	35.33	46.00	-10.67	Peak	100	0

Notes:

1. Result = Read Value + Factor
2. Factor = Antenna Factor + Cable Loss - Amplifier
3. The resolution bandwidth of test receiver/spectrum analyzer is 120KHz and video bandwidth is 300kHz for Peak detection and Quasi-peak detection at frequency below 1GHz.
4. According to technical experiences, all spurious emission of FSK mode at channel 1,6,11 are almost the same below 1GHz, so that the channel 1 was chosen as representative in final test.
5. The data is worse case.



Power	: DC 5V	Pol/Phase	: VERTICAL
Test Mode	: Transmit/ Receive	Temperature	: 26 °C
Operation Channel	: 1	Humidity	: 57 %
Modulation Type	: FSK	Atmospheric Pressure	: 1021 hPa

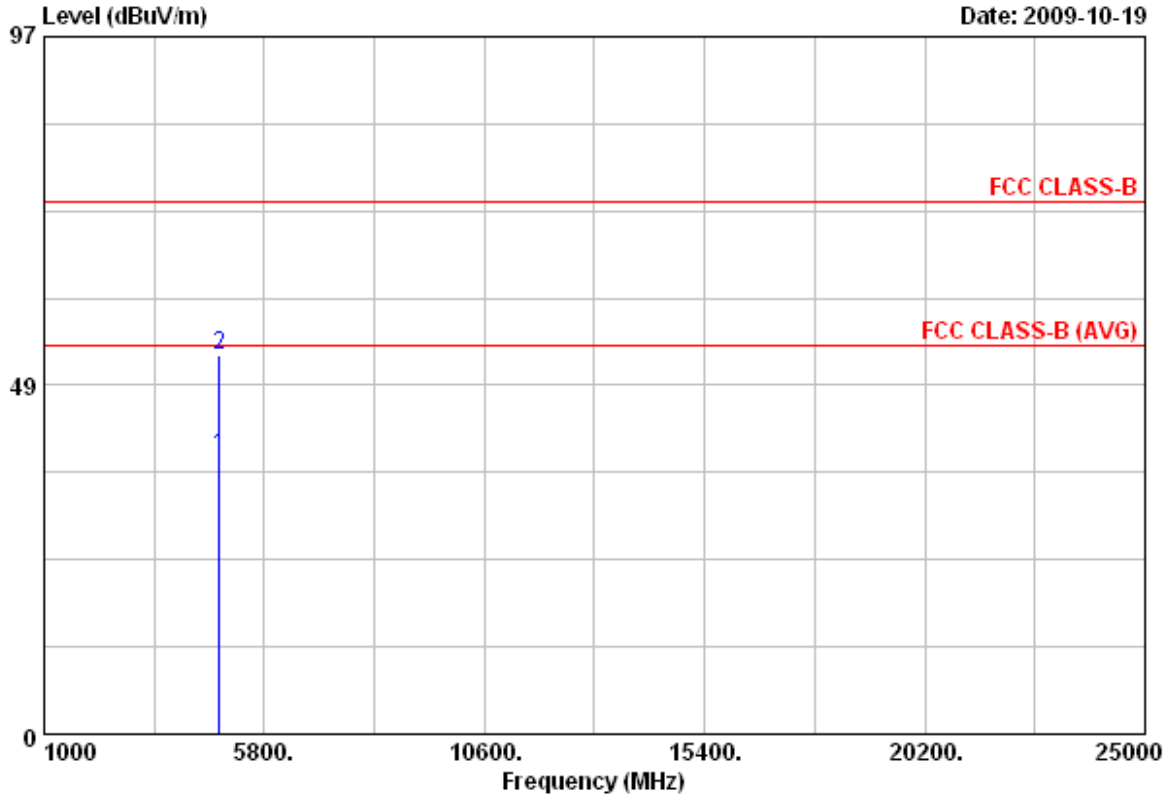

Item	Freq	Read Value	Factor	Result	Limit	Margin	Remark	Ant Pos	Tab Pos
	MHz	dBuV	dB/m	dBuV/m	dBuV/m	dB		cm	Deg
1	4810.75	30.95	7.66	38.61	54.00	-15.39	Average	100	360
2	4811.29	45.09	7.66	52.75	74.00	-21.25	Peak	100	360

Notes:

1. Result = Read Value + Factor
2. Factor = Antenna Factor + Cable Loss - Amplifier
3. The resolution bandwidth of test receiver/spectrum analyzer is 120KHz and video bandwidth is 300kHz for Peak detection and Quasi-peak detection at frequency below 1GHz.
4. The resolution bandwidth of test receiver/spectrum analyzer is 1MHz and video bandwidth is 3MHz for Peak detection at frequency above 1GHz.
5. The resolution bandwidth of test receiver/spectrum analyzer is 1MHz and video bandwidth is 10Hz for Average detection at frequency above 1GHz.
6. The other emissions is too low to be measured.



Power	: DC 5V	Pol/Phase	: HORIZONTAL
Test Mode	: Transmit/ Receive	Temperature	: 26 °C
Operation Channel	: 1	Humidity	: 57 %
Modulation Type	: FSK	Atmospheric Pressure	: 1021 hPa

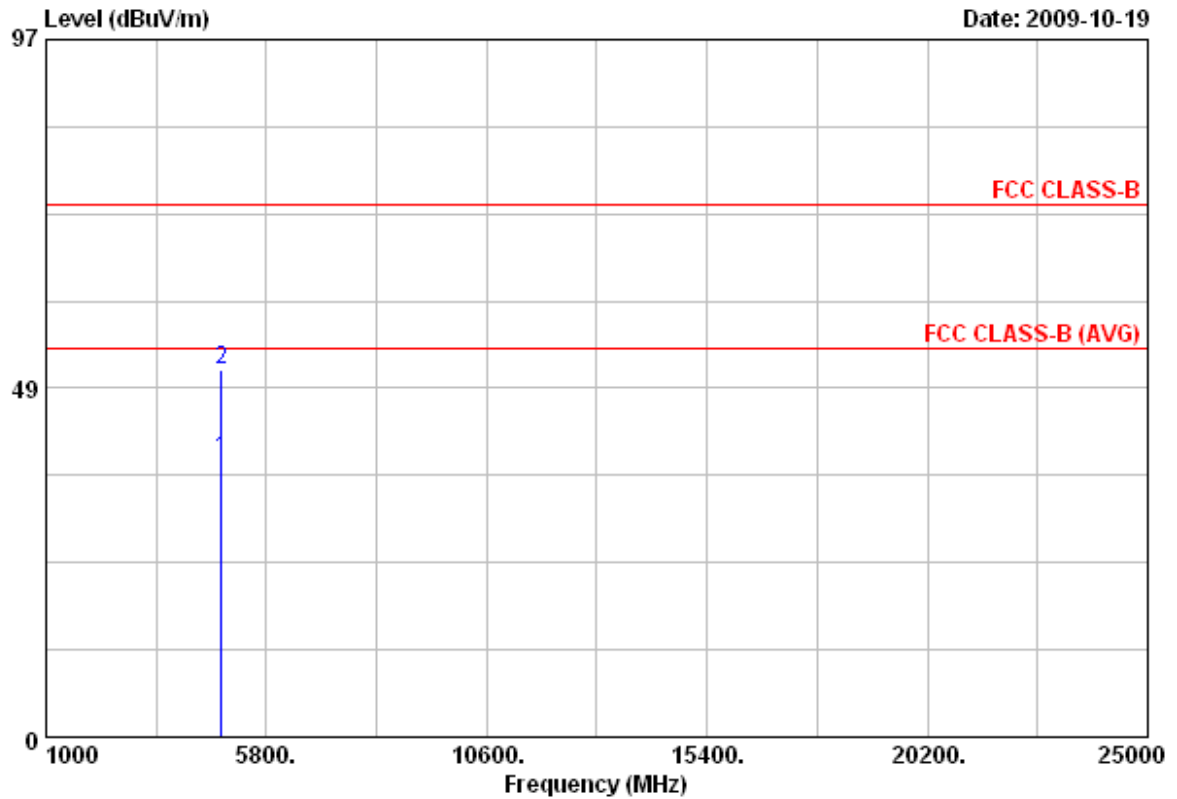

Item	Freq	Read Value	Factor	Result	Limit	Margin	Remark	Ant Pos	Tab Pos
	MHz	dBuV	dB/m	dBuV/m	dBuV/m	dB		cm	Deg
1	4810.00	31.03	7.65	38.68	54.00	-15.32	Average	100	0
2	4811.75	43.43	7.66	51.09	74.00	-22.91	Peak	100	0

Notes:

1. Result = Read Value + Factor
2. Factor = Antenna Factor + Cable Loss - Amplifier
3. The resolution bandwidth of test receiver/spectrum analyzer is 120KHz and video bandwidth is 300kHz for Peak detection and Quasi-peak detection at frequency below 1GHz.
4. The resolution bandwidth of test receiver/spectrum analyzer is 1MHz and video bandwidth is 3MHz for Peak detection at frequency above 1GHz.
5. The resolution bandwidth of test receiver/spectrum analyzer is 1MHz and video bandwidth is 10Hz for Average detection at frequency above 1GHz.
6. The other emissions is too low to be measured.



Power	: DC 5V	Pol/Phase	: VERTICAL
Test Mode	: Transmit/ Receive	Temperature	: 26 °C
Operation Channel	: 6	Humidity	: 57 %
Modulation Type	: FSK	Atmospheric Pressure	: 1021 hPa

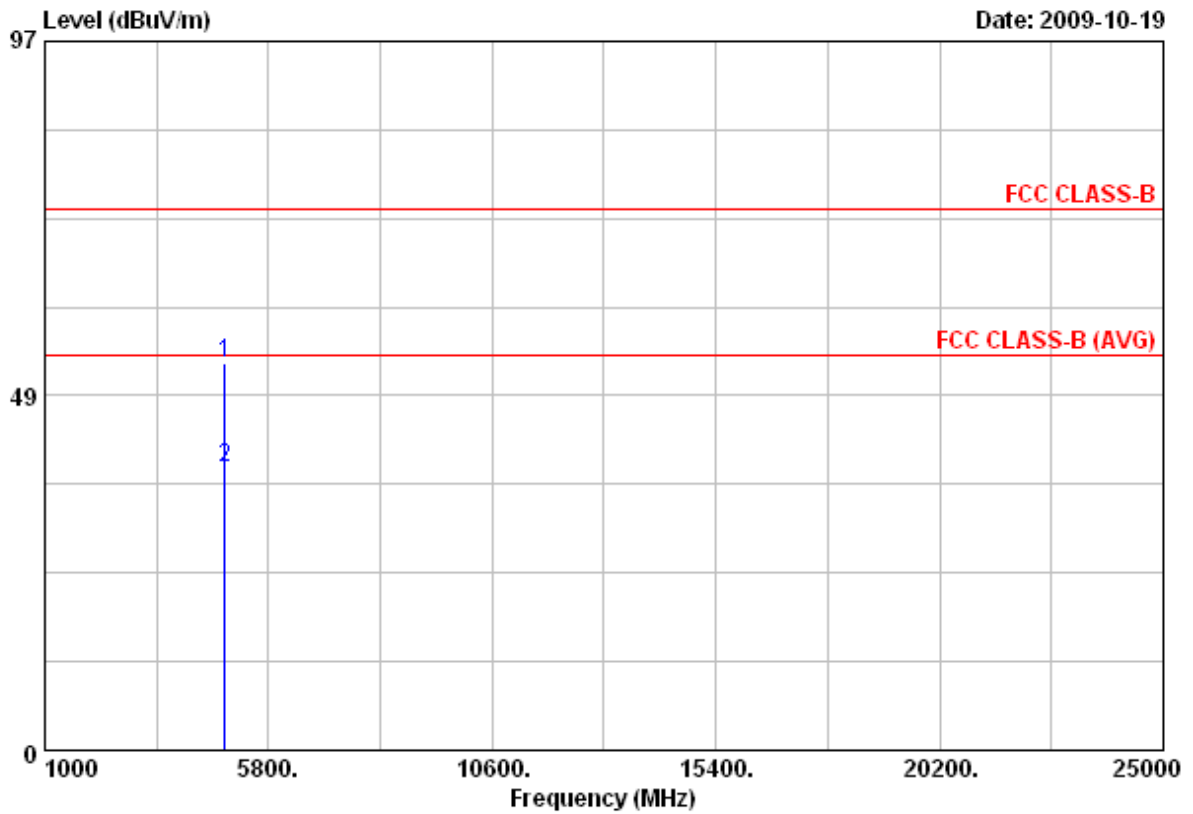

Item	Freq	Read Value	Factor	Result	Limit	Margin	Remark	Ant Pos	Tab Pos
	MHz	dBuV	dB/m	dBuV/m	dBuV/m	dB		cm	Deg
1	4860.00	45.06	7.82	52.88	74.00	-21.12	Peak	100	360
2	4860.88	30.86	7.83	38.69	54.00	-15.31	Average	100	360

Notes:

1. Result = Read Value + Factor
2. Factor = Antenna Factor + Cable Loss - Amplifier
3. The resolution bandwidth of test receiver/spectrum analyzer is 120KHz and video bandwidth is 300kHz for Peak detection and Quasi-peak detection at frequency below 1GHz.
4. The resolution bandwidth of test receiver/spectrum analyzer is 1MHz and video bandwidth is 3MHz for Peak detection at frequency above 1GHz.
5. The resolution bandwidth of test receiver/spectrum analyzer is 1MHz and video bandwidth is 10Hz for Average detection at frequency above 1GHz.
6. The other emissions is too low to be measured.



Power	: DC 5V	Pol/Phase	: HORIZONTAL
Test Mode	: Transmit/ Receive	Temperature	: 26 °C
Operation Channel	: 6	Humidity	: 57 %
Modulation Type	: FSK	Atmospheric Pressure	: 1021 hPa

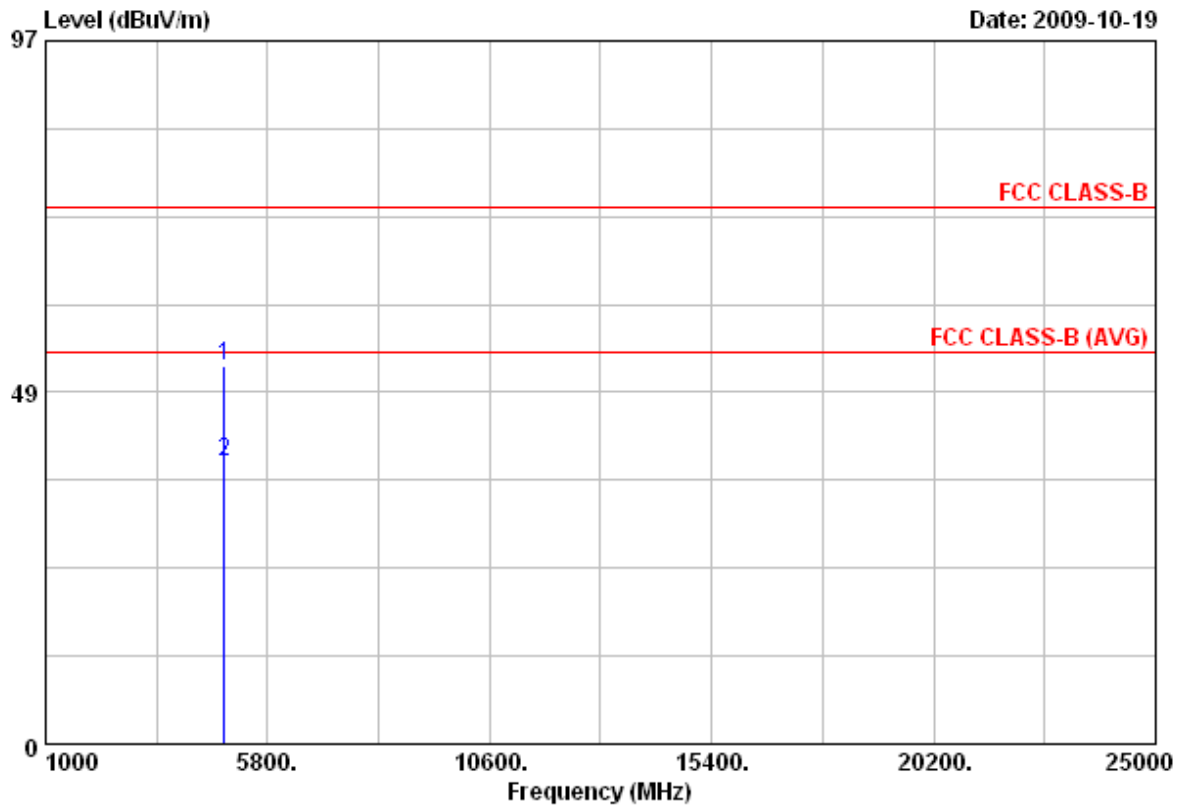

Item	Freq	Read Value	Factor	Result	Limit	Margin	Remark	Ant Pos	Tab Pos
	MHz	dBuV	dB/m	dBuV/m	dBuV/m	dB		cm	Deg
1	4860.25	44.20	7.82	52.02	74.00	-21.98	Peak	100	0
2	4860.75	30.97	7.83	38.80	54.00	-15.20	Average	100	0

Notes:

1. Result = Read Value + Factor
2. Factor = Antenna Factor + Cable Loss - Amplifier
3. The resolution bandwidth of test receiver/spectrum analyzer is 120KHz and video bandwidth is 300kHz for Peak detection and Quasi-peak detection at frequency below 1GHz.
4. The resolution bandwidth of test receiver/spectrum analyzer is 1MHz and video bandwidth is 3MHz for Peak detection at frequency above 1GHz.
5. The resolution bandwidth of test receiver/spectrum analyzer is 1MHz and video bandwidth is 10Hz for Average detection at frequency above 1GHz.
6. The other emissions is too low to be measured.



Power	: DC 5V	Pol/Phase	: VERTICAL
Test Mode	: Transmit/ Receive	Temperature	: 26 °C
Operation Channel	: 11	Humidity	: 57 %
Modulation Type	: FSK	Atmospheric Pressure	: 1021 hPa

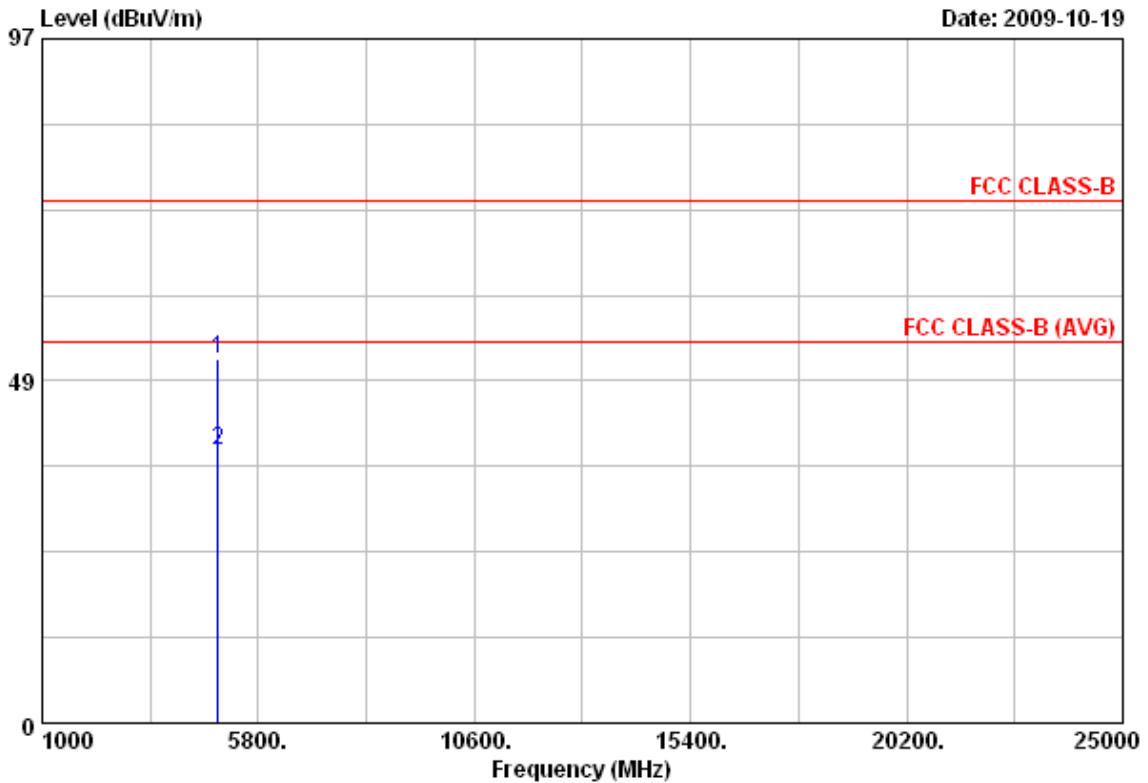

Item	Freq	Read Value	Factor	Result	Limit	Margin	Remark	Ant Pos	Tab Pos
	MHz	dBuV	dB/m	dBuV/m	dBuV/m	dB		cm	Deg
1	4910.50	43.55	7.99	51.54	74.00	-22.46	Peak	100	0
2	4910.88	30.63	8.00	38.63	54.00	-15.37	Average	100	0

Notes:

1. Result = Read Value + Factor
2. Factor = Antenna Factor + Cable Loss - Amplifier
3. The resolution bandwidth of test receiver/spectrum analyzer is 120KHz and video bandwidth is 300kHz for Peak detection and Quasi-peak detection at frequency below 1GHz.
4. The resolution bandwidth of test receiver/spectrum analyzer is 1MHz and video bandwidth is 3MHz for Peak detection at frequency above 1GHz.
5. The resolution bandwidth of test receiver/spectrum analyzer is 1MHz and video bandwidth is 10Hz for Average detection at frequency above 1GHz.
6. The other emissions is too low to be measured.



Power	: DC 5V	Pol/Phase	: HORIZONTAL
Test Mode	: Transmit/ Receive	Temperature	: 26 °C
Operation Channel	: 11	Humidity	: 57 %
Modulation Type	: FSK	Atmospheric Pressure	: 1021 hPa

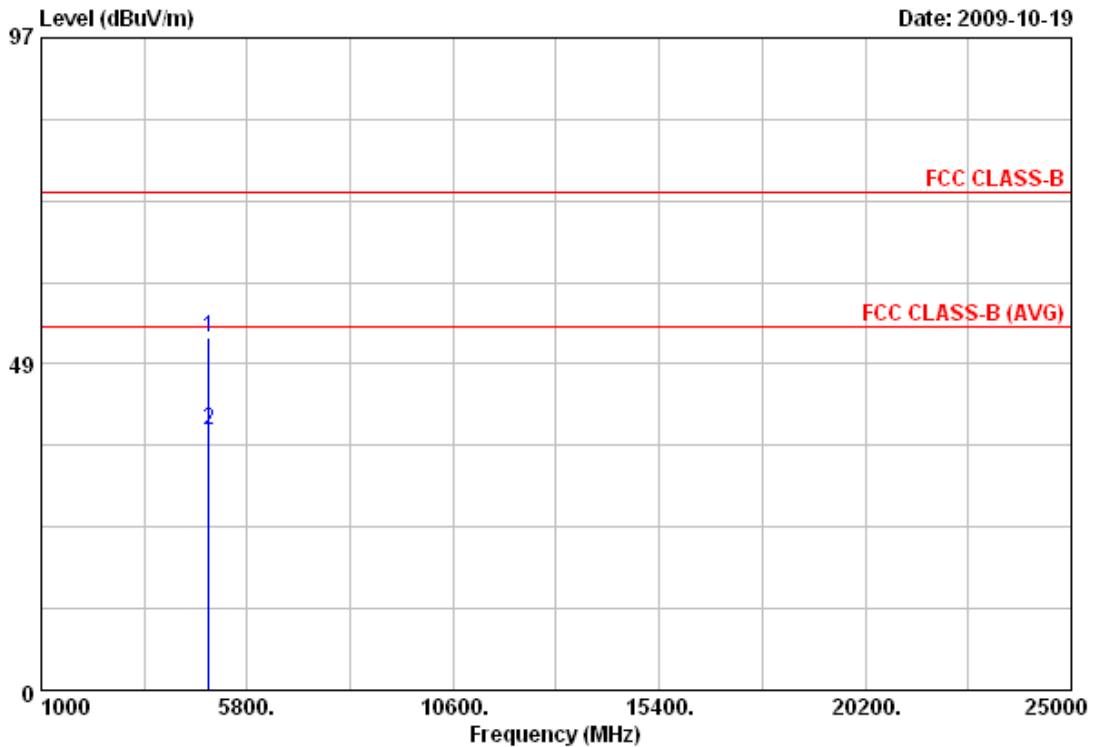

Item	Freq	Read Value	Factor	Result	Limit	Margin	Remark	Ant Pos	Tab Pos
	MHz	dBuV	dB/m	dBuV/m	dBuV/m	dB		cm	Deg
1	4910.38	44.39	7.99	52.38	74.00	-21.62	Peak	100	194
2	4910.50	30.63	7.99	38.62	54.00	-15.38	Average	100	63

Notes:

1. Result = Read Value + Factor
2. Factor = Antenna Factor + Cable Loss - Amplifier
3. The resolution bandwidth of test receiver/spectrum analyzer is 120KHz and video bandwidth is 300kHz for Peak detection and Quasi-peak detection at frequency below 1GHz.
4. The resolution bandwidth of test receiver/spectrum analyzer is 1MHz and video bandwidth is 3MHz for Peak detection at frequency above 1GHz.
5. The resolution bandwidth of test receiver/spectrum analyzer is 1MHz and video bandwidth is 10Hz for Average detection at frequency above 1GHz.
6. The other emissions is too low to be measured.

Test engineer: Ben



7. 20dB Occupied Bandwidth Measurement

7.1. Test Procedure

- a. The EUT placed on the turning table.
- b. The signal was coupled to the spectrum analyzer through an antenna.
- c. Set the resolution bandwidth to 100kHz and video bandwidth to 100kHz then select Peak function to scan the channel frequency.
- d. The 20dB bandwidth was measured and recorded.

7.2. Test Setup Layout

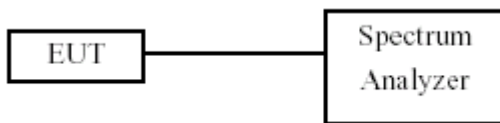

7.3. Limits of Band Edges Measurement

The bandwidth of the emission shall be no wider than 0.25% of the center frequency for device operating above 70 MHz and above 900 MHz.

Frequency (MHz)	Limit of 20dB Bandwidth (MHz)
2400	12.00
2440	12.20
2471	12.35

7.4. Measurement equipment

Instrument/Ancillary	Model No.	Manufacturer	Serial No.	Calibration Date	Valid Date
Spectrum Analyzer	FSP40	R&S	10047	2009/03/26	2010/03/25

7.5. Test Result

Frequency (MHz)	20 dB bandwidth (MHz)	PASS / FAIL
2400	0.260	PASS
2440	0.256	PASS
2471	0.260	PASS



Frequency: 2400MHz, CH1

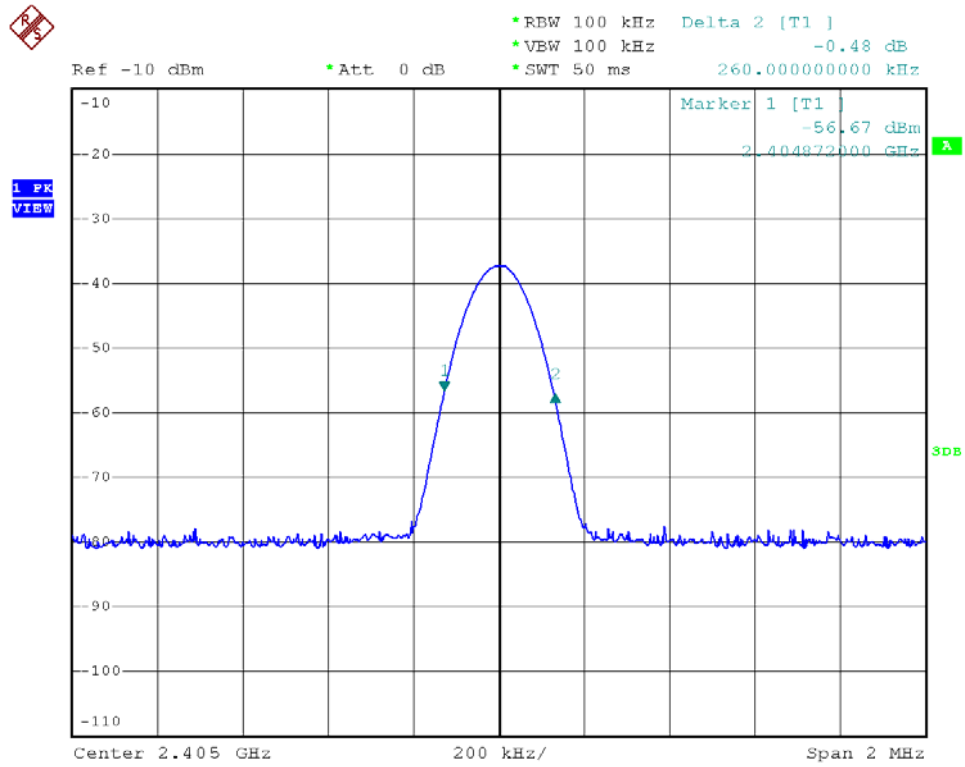

Frequency: 2440MHz, CH6

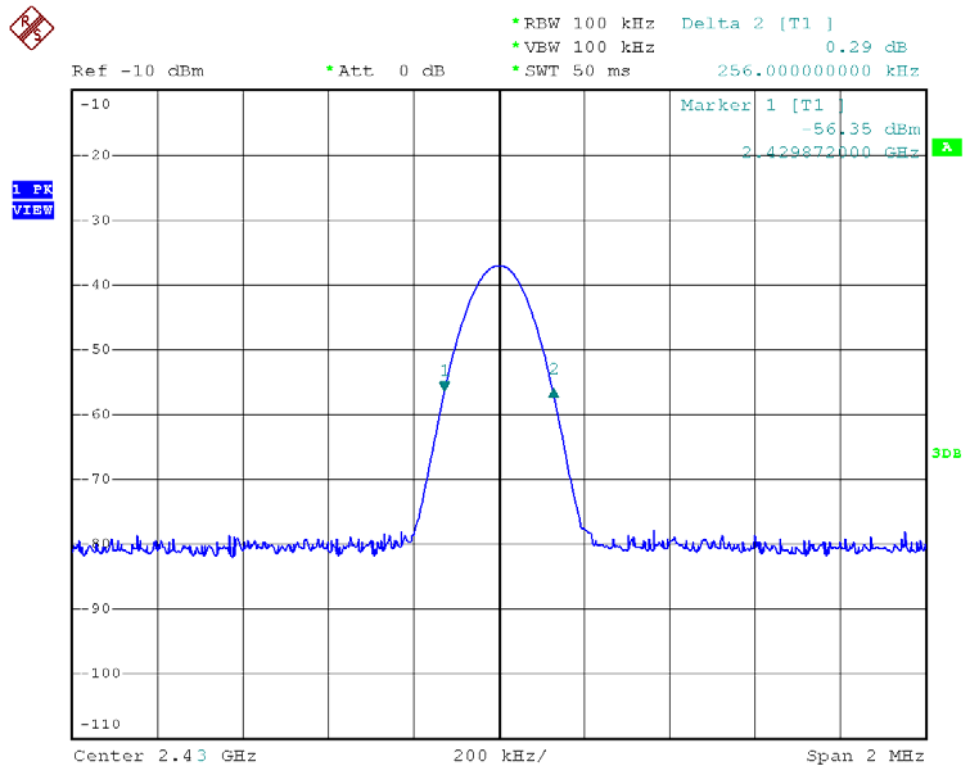



Frequency: 2455MHz, CH11



*RBW 100 kHz Delta 2 [T1]
*VEW 100 kHz -0.11 dB
*SWT 50 ms 260.000000000 kHz

Ref -10 dBm

*Att 0 dB

260.000000000 kHz

PK
VIEW

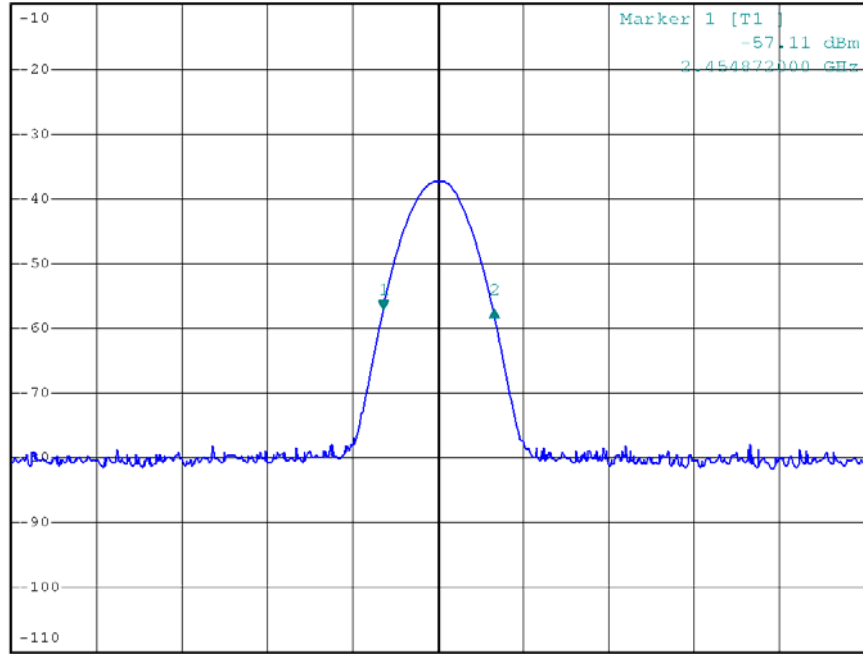



8. Transmission Time Control

8.1. Test Procedure

1. Set up the EUT in the state of Transmitter.
2. Set up the Spectrum, judge whether to accord with the regulation demand or not.

8.2. Test Setup Layout

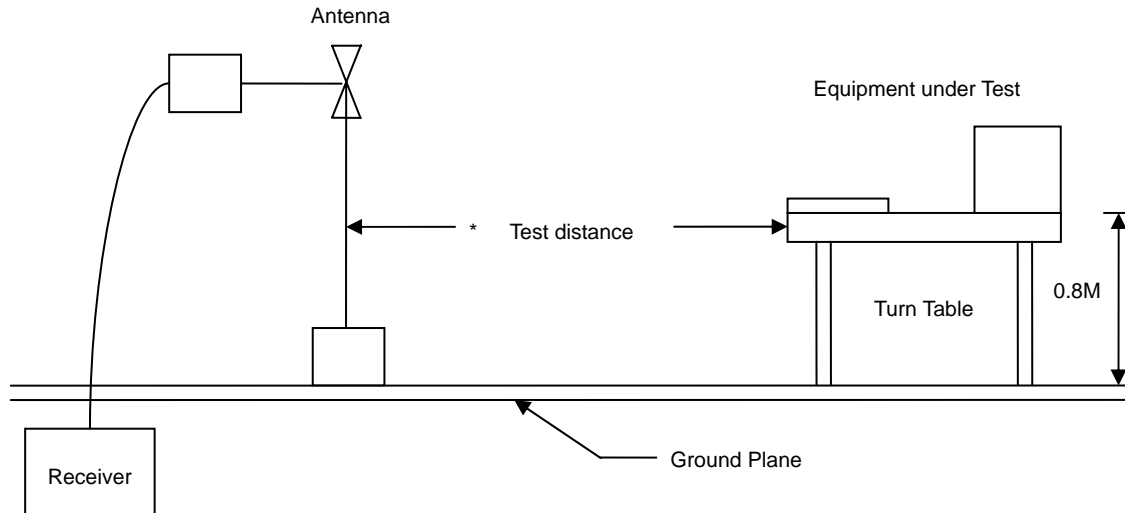

8.3. Test Limit

Limits: A manually operated transmitter shall employ a switch that will automatically deactivate the transmitter within not more than 5 seconds of being released.

8.4. Measurement equipment

Instrument/Ancillary	Model No.	Manufacturer	Serial No.	Calibration Date	Valid Date
Spectrum Analyzer	FSP40	R&S	10047	2009/03/26	2010/03/25

8.5. Test Result

Test date : Sep. 21, 2009 Ambient temperature : 25
 Atmospheric pressure : 1010hpa Relative humidity : 65%

Frequency (MHz)	Operation time(Sec.)	Limit(Sec.)	PASS / FAIL
2440	0.36	5.00	PASS



Frequency: 2455MHz, CH11

