

PVS6 Residential Installation Quick Start Guide

Follow these instructions to install and commission the PV Supervisor 6 (PVS6) to receive monitoring data. **Refer to the *Equinox Installation Guide (518101)* for the complete Equinox system installation instructions.**

Intended Use: The PVS6 is a datalogger-gateway device used for solar system and home monitoring, metering, and control.

SUNPOWER[®]

51 Rio Robles San Jose CA 95134
www.sunpower.com 1.408.240.5500

Kit includes:

- PV Supervisor 6 (PVS6)
- Mounting bracket
- (2) Screws
- (2) Hole plugs
- (2) 100 A Current Transformers (shipped separately)

You will need:

- Phillips and small flathead screwdriver
- Hardware that supports 6.8 kg (15 lbs) to install the bracket
- RJ45 crimp tool
- Wire cutter and stripper
- Step drill (Optional)
- Laptop with latest Chrome or Firefox version installed
- Ethernet cable
- Your SunPower monitoring website credentials
- (Optional) Customer's WiFi network and password

Routing wire and cable:

- **Fill all openings in the enclosure with components rated NEMA Type 4 or better to maintain the integrity of the enclosure's environmental system.**
- Drill extra openings with step drill (**do not** use screwdriver or hammer).
- Use only the provided conduit openings or drillout locations and never cut holes in the top or sides of the enclosure.
- Never run inverter or Ethernet communication cable in the same conduit as AC wiring.
- CT and AC wiring may be run in the same conduit.
- The max. allowable conduit size for PVS6 is 3/4".

Input

208 VAC (L-L) CAT III 50/60 Hz, 0.2 A, 35 W; **OR**
240 VAC (L-L) from a split-phase three-wire system CAT III, 50/60 Hz, 0.2 A, 35 W.

Environmental Ratings

Pollution Degree 2; -30°C to +60°C operating ambient temp.; 15-95% non-condensing humidity; max. altitude 2000 m; outdoor use; Type 3R enclosure.

1. Mount the PVS6

1. Select an installation location that is not in direct sunlight.
2. Mount the PVS6 bracket to the wall using appropriate hardware for the mounting surface and that can support at least 6.8 kg (15 lbs).
3. Fit the PVS6 onto the bracket until the mounting holes at the bottom are aligned.
4. Use a screwdriver to secure the PVS6 to the bracket using the provided screws. Do not overtighten.

2. Wire the PVS6 power



Danger! Hazardous voltages! Do not power up the system until after you complete Sections 1 through 3. Accessing the system involves possible contact with potentially lethal voltages and currents. No attempt to access, install, adjust, repair, or test the system should be made by anyone who is not qualified to work on such equipment. Use copper conductors only, with min. 75°C temp. rating.

1. Use a screwdriver—do not use power tools—to prepare the PVS6 for AC wiring:
 - Using a flat-blade screwdriver, carefully bend the PVS6 cover retention tab back to release and then remove the outer cover
 - Remove the lower AC wiring cover
 - Remove the upper AC wiring cover
2. Run power conduit from the service panel to the PVS6. If you use the rear conduit entrances, seal the holes on the bottom of the enclosure with the included hole plugs. Use step drill if you are using rear or center bottom entrances.
3. Connect the PVS6 to either a 15 A (with 14 AWG) or a 20 A (with 12 AWG) UL Listed dedicated dual-pole breaker.
Note: For AC modules, this breaker should be in the same service panel containing the AC module output circuits.
4. Strip wires to 12 mm and land according to the color-coded labels (black wire to **L1**, red wire to **L2**, the white wire to **N**, and green wire to **GND**) in the J2 terminals on the bottom left of the PVS6 board, and then close each locking lever completely.

3. Install and wire the consumption CTs



Danger! Hazardous voltages! Do not power up the system until after you complete Sections 1 through 3. Accessing the system involves possible contact with potentially lethal voltages and currents. No attempt to access, install, adjust, repair, or test the system should be made by anyone who is not qualified to work on such equipment.

Max. 120/240 VAC split phase, three wire system, Measurement Category III, 0.333 VAC from a current sensor rated to measure max. 50 A.

The SunPower-provided CTs are suitable for use on 200 A conductors. CTs may be labeled "100 A" but this is a calibration reference rating only. You may install CTs in parallel or bundled configurations. **Refer to the *Consumption Meter CT Installation Instructions*.**

1. Turn off all power to the main service panel in which you are installing CTs.
2. Place the CTs in the main service panel, around incoming service conductors, with the side labeled **THIS SIDE TOWARD SOURCE** toward the utility meter and away from the loads. Never install CTs in the utility-designated section of the service panel.
 - Place **L1 CT** (black and white wires) around incoming Line 1 service conductor
 - Place **L2 CT** (red and white wires) around incoming Line 2 service conductor
3. Align the steel core pieces and snap the CTs closed.
4. Route CT wires through conduit to PVS6.
 - **Running CT wires:** You may run CT and AC wiring in the same conduit. Do not run CT wiring and internet communication cables in the same conduit.
 - **Extending CT leads:** Use Class 1 (600 V rated minimum, 16 AWG maximum) twisted-pair instrument cable and appropriate connectors; SunPower recommends the use of silicone-filled insulation displacement connectors (IDC) or telecom crimps; do not use power cables (for example, THWN or Romex) to extend the CT leads.

5. Land **L1 CT** and **L2 CT** wires in corresponding **CONS L1** and **CONS L2** in the J3 terminals on the bottom, right terminals of the PVS6 board. Tighten to 0.5-0.6 N-m (4.4-5.3 in-lb). If you shorten the leads, strip no more than 7 mm (7/25").
Caution! Do not overtighten terminals.

4. Verify CT voltage phases

1. Turn on power to the PVS6.
2. Use a voltmeter to measure voltage between the PVS6 L1 terminal and the L1 incoming service conductor in the main service panel with the L1 CT in place.
3. If the voltmeter reads:
 - 0 (zero) V the phases are correctly aligned.
 - 240 V the phases are incorrectly aligned. Move the CT to the other incoming service conductor and retest to verify zero V.
4. Repeat Steps 4.2 and 4.3 for L2.

5. Connect the system communication

1. Replace the upper AC wiring cover.
2. Replace the lower AC wiring cover over the AC power wires (on the left if you ran through left hole; on the right if you ran through the right hole).
3. Run communication conduit to the PVS6 conduit opening if required. If you use the rear conduit entrances, seal the holes on the bottom of the enclosure with the included hole plugs.
Warning! Never run inverter communications cable in same conduit as AC wiring.
4. Connect communication for each device using corresponding port:
 - **AC modules:** Verify that you connected the AC modules to the AC module subpanel. No additional connection is required, the PVS6 communicates with AC Modules using PLC protocol.
 - **SMA US-22 inverter:** Connect an RS-485 communication cable from the PVS6 **RS-485 2-WIRE** port (blue) and to the first (or only) inverter in the daisy chain. Follow the manufacturer's instructions to daisy-chain additional SMA US-22 inverters.
 - **SMA US-40 inverter:** Connect a tested Ethernet cable from the PVS6 **LAN1** port to first (or only) SMA US-40 port A or B. Follow the manufacturer's instructions to daisy-chain additional SMA US-40 inverters using Ethernet cables.

6. Connect the PVS6 to the internet

Connect to customer's Internet using either:

- **Ethernet cable:** from PVS6 LAN2 to customer's router (**recommended method**)
- **Customer's WiFi network:** connect during commission using customer's WiFi network name and password

7. Commission with the PVS Management App

1. Turn laptop WiFi off.
2. Use an Ethernet cable to connect your laptop to either the PVS6 or the inverter based on installation type:
 - **AC module or SMA US-22:** Connect laptop to PVS6 **LAN 1** port.
 - **SMA US-40 inverter:** Connect laptop to available communication port (**A or B**) in the last (only) inverter.
3. Open a browser (the latest version of either Chrome or Firefox) and type: www.sunpowerconsole.com.
4. Follow the PVS Management App onscreen instructions.
5. Replace the PVS6 enclosure cover by snapping it into place.

If the equipment is used in a manner not specified by SunPower, the protection provided by the equipment may be impaired.

Safety & Certifications

Safety Instructions

Installation and field service is to be performed only by qualified, trained personnel with the necessary skills and knowledge to work on this type of electrical device. Field service is limited to the components contained in the lower compartment of the PVS6.

- Perform all electrical installations in accordance with any national and local codes, such as the National Electrical Code (NEC) ANSI/NFPA 70.
- This enclosure is suitable for use indoors or outdoors (NEMA Type 3R). Operating ambient from -30°C to 60°C.
- Before connecting power, the PVS6 must be securely mounted to an inside or outside wall following the instructions in this document.
- For electrical wiring code compliance, connect the PVS6 to a dedicated UL Listed 15 A rated breaker using 14 AWG wiring, or a UL Listed 20 A rated breaker using 12 AWG wiring. The input operating current is less than 0.1 amp with AC nominal voltages of 240 VAC (L1-L2).
- The PVS6 contains internal transient surge protection for connection to the load side of the service entrance AC service panel (overvoltage category III). For installations in areas at risk of surges generated by high-voltage utilities, industry, or by lightning, it is recommended that a UL Listed external surge protective device also be installed.
- Do not attempt to repair the PVS6. Tampering with or opening the upper compartment voids the product warranty.
- Use only UL Listed, double-insulated, XOBA CTs with the PVS6.

Safety Certification

- UL Listed to UL 61010 and UL 50 for outdoor use.
- The PVS6 is not a utility meter, disconnect device, or power distribution device.

FCC Compliance

This device complies with Part 15 of the FCC Rules. Operation is subject to the following two conditions:

- (1) This device may not cause harmful interference, and
 - (2) This device must accept any interference received, including interference that may cause undesired operation.
- NOTE:** This equipment has been tested and found to comply with the limits for a Class B digital device, pursuant to Part 15 of the FCC Rules. These limits are designed to provide reasonable protection against harmful interference in a residential installation. This equipment generates, uses, and can radiate radio frequency energy and, if not installed and used in accordance with the instructions, may cause harmful interference to radio communications. However, there is no guarantee that interference will not occur in a particular installation. If this equipment does cause harmful interference to radio or television reception, which can be determined by turning the equipment off and on, try to correct the interference by one or more of the following measures:
- Reorient or relocate the receiving antenna.
 - Increase the separation between the equipment and receiver.
 - Connect the equipment into an outlet on a circuit different from that to which the receiver is connected.

IMPORTANT NOTES: Radiation Exposure Statement

This equipment complies with FCC RF radiation exposure limits set forth for an uncontrolled environment. This equipment should be installed and operated with minimum distance 20 cm (7.87 in) between the device and your body.

CAUTION:

Changes or modifications not expressly approved by the party responsible for compliance could void the user's authority to operate the equipment. This device and its antenna(s) must not be co-located or operating in conjunction with any other antenna or transmitter except in accordance with FCC multi-transmitter product procedures.

PVS6 Quick Start Guide

Follow these instructions to install, configure, and commission the PV Supervisor 6 (PVS6) to begin receiving monitoring data. Refer to the *PVS6 Installation Instructions* on the other side for the complete instructions. **Note that the PVS6 is integrated into the Hub+™ in SunVault™ systems!**

PVS6 Connection Diagram: AC Module Site

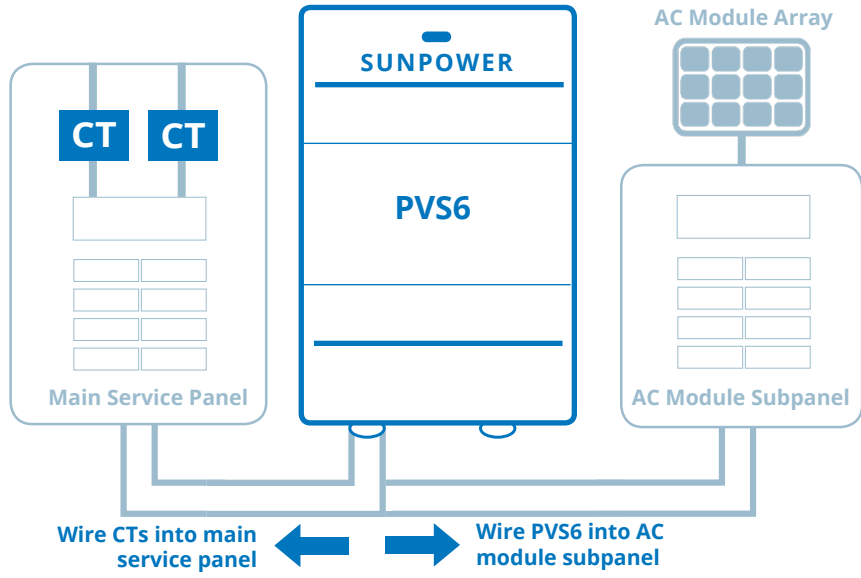

PVS6 Connection Diagram: DC Inverter Site

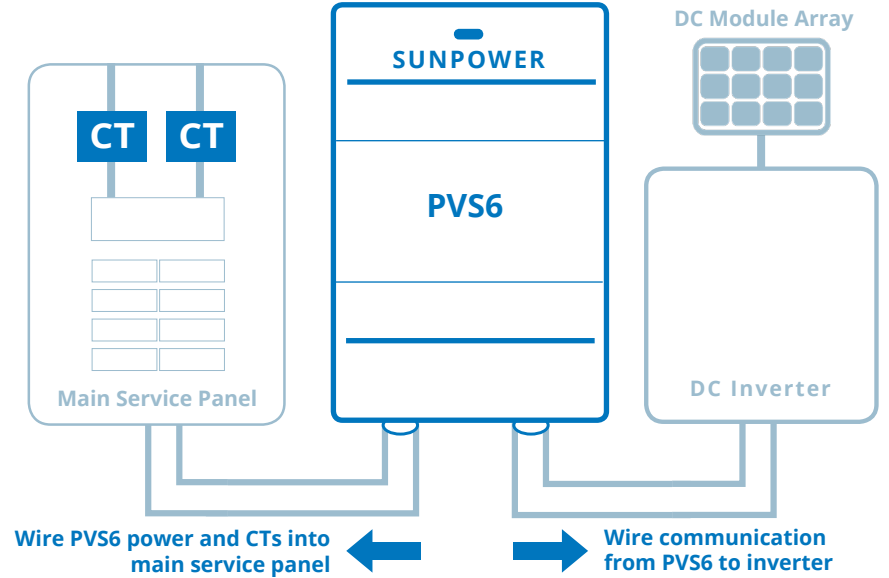

Routing wire and cable:

- Fill all conduit openings in the enclosure with components rated NEMA Type 4 or better to maintain the integrity of the enclosure's environmental system.
- Drill extra 0.875" (22 mm) or 1.11" (28 mm) conduit openings, if required, with step drill (**do not** use screwdriver or hammer).
- Use only the provided conduit openings or drillout locations and never cut holes in the top or sides of the enclosure.
- Never run inverter or Ethernet communication cable in the same conduit as AC wiring.
- CT and AC wiring may be run in the same conduit.

1. Mount the PVS6

Mount the PVS6 bracket to the wall using hardware that supports 6.8 kg (15 lb); use Phillips screwdriver to secure the PVS6 to the bracket using the two provided screws.

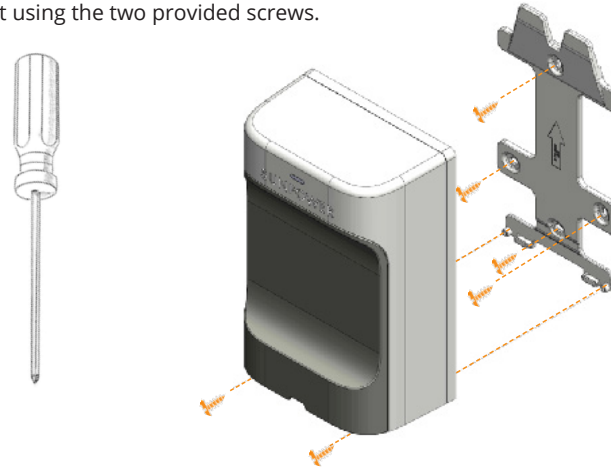

2. Remove all PVS6 covers

Use flathead screwdriver to carefully remove the enclosure cover. Use Phillips to remove the AC wiring covers.

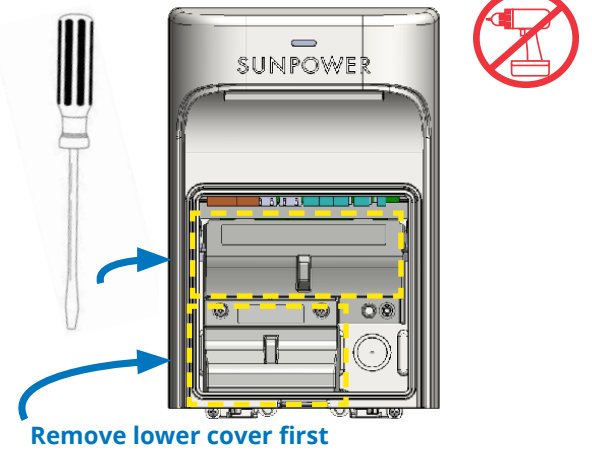

3. Wire PVS6 power

Use copper conductors only, with min. 75°C temp. rating. Install a dedicated 240 or 208 VAC circuit. Land wires in J2 terminals: green to GND; black to L1; white to N; and red to L2.

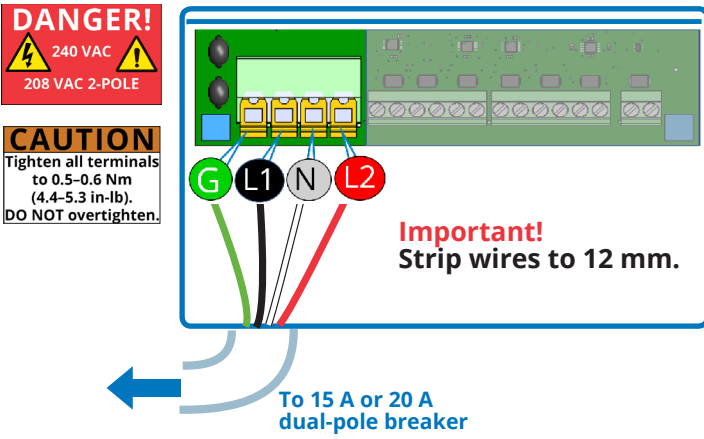

4. Install consumption CTs

Refer to Section 3 on the other side for complete CT installation instructions. Place CTs around incoming service conductors: L1 CT (black and white wires) around Line 1 and L2 CT (red and white wires) around Line 2.

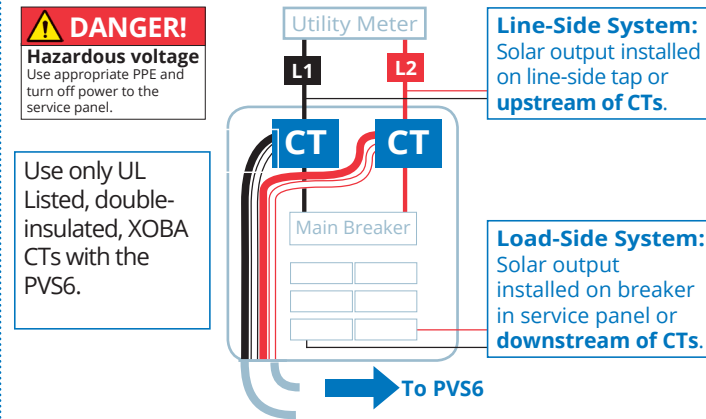

5. Wire consumption CTs

Land wires in J3 terminals: L1 CT and L2 CT wires to corresponding CONS L1 and CONS L2.

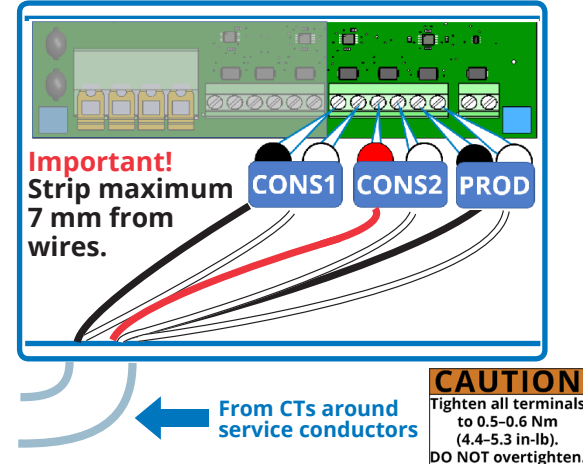

6. Replace PVS6 wiring covers

Use screwdriver to replace AC wiring covers over AC power wires.

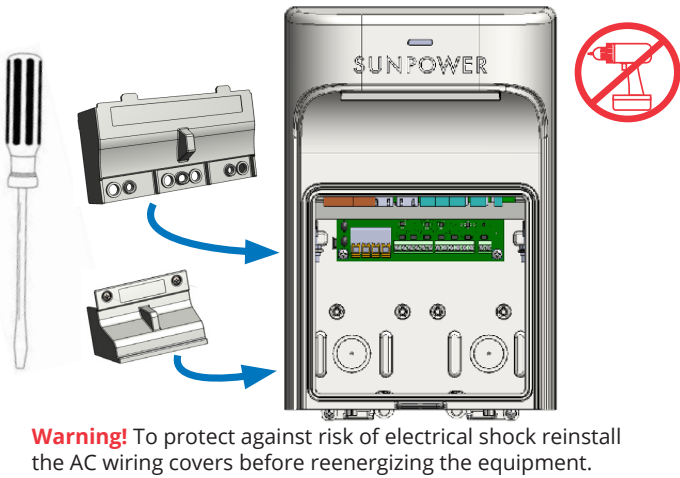

7. Connect DC inverter communication

If DC inverter is installed, connect communication from DC inverter to the PVS6. No additional connection is required for AC modules.

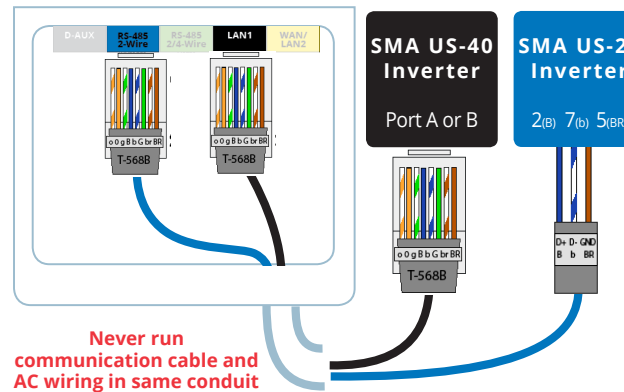

8. Connect PVS6 to the internet

Connect to customer's internet with either:

- **Ethernet Cable**
From PVS6 LAN2 to customer's router (recommended method).
- **Customer's WiFi**
Connect during commissioning with network and password.

9. Commission with SPPC App

Open the SunPower Pro Connect (SPPC) app and follow the onscreen instructions to commission the system.



10. Replace PVS6 cover

Snap the enclosure cover onto the PVS6.



- Always open or disconnect circuit from power-distribution system (or service) of building before installing or servicing current transformers (CTs).
- The CTs may not be installed in equipment where they exceed 75% of the wiring space of any cross-sectional area within the equipment.
- Restrict installation of CT in an area where it would block ventilation openings.
- Restrict installation of CT in an area of breaker arc venting.
- Not suitable for Class 2 wiring methods.
- Not intended for connection to Class 2 equipment
- Secure CT, and route conductors so that they do not directly contact live terminals or bus.
- **WARNING!** To reduce the risk of electric shock, always open or disconnect circuit from power-distribution system (or service) of building before installing or servicing CTs.
- For use with UL Listed Energy Monitoring Current Sensors rated for Double Insulation.

Title Identifying New PVS6 Ethernet Connection Ports, 650368
Date July 21, 2022
Authors Applications Engineering Team
Application SunPower Equinox® and SunPower® SunVault™ Storage installations

Overview

The SunPower PVS6 monitoring device now utilizes a plug-in dongle port for Ethernet connection. The PVS6 with the dongle port is part number 60232 and has a **W** in its serial number (for example, ZT214385000549**W**xxxx). The traditional PVS6 without the dongle port is part number 529027 and has an **A** in its serial number (for example, ZT214385001823**A**xxxx).

This Tech Note describes how to install each of these.

Note: During the commissioning process, SunPower Pro Connect will automatically assess the PVS6 serial number and will provide a popup message alerting you **if** your PVS6 lacks the traditional Ethernet ports.

Identifying Which Variant You Have

View the serial number on the PVS6:

- If it contains an **A** (for example, ZT214385001823**A**xxxx), the **Ethernet ports are still present** and may still be used for commissioning. No dongle is required.
- If it contains a **W** (for example, ZT214385000549**W**xxxx) the **Ethernet ports are not present**, meaning that for commissioning you must use a dongle.

PVS6 units with an **A** in their serial number will likely look familiar because all the standard ports are present:

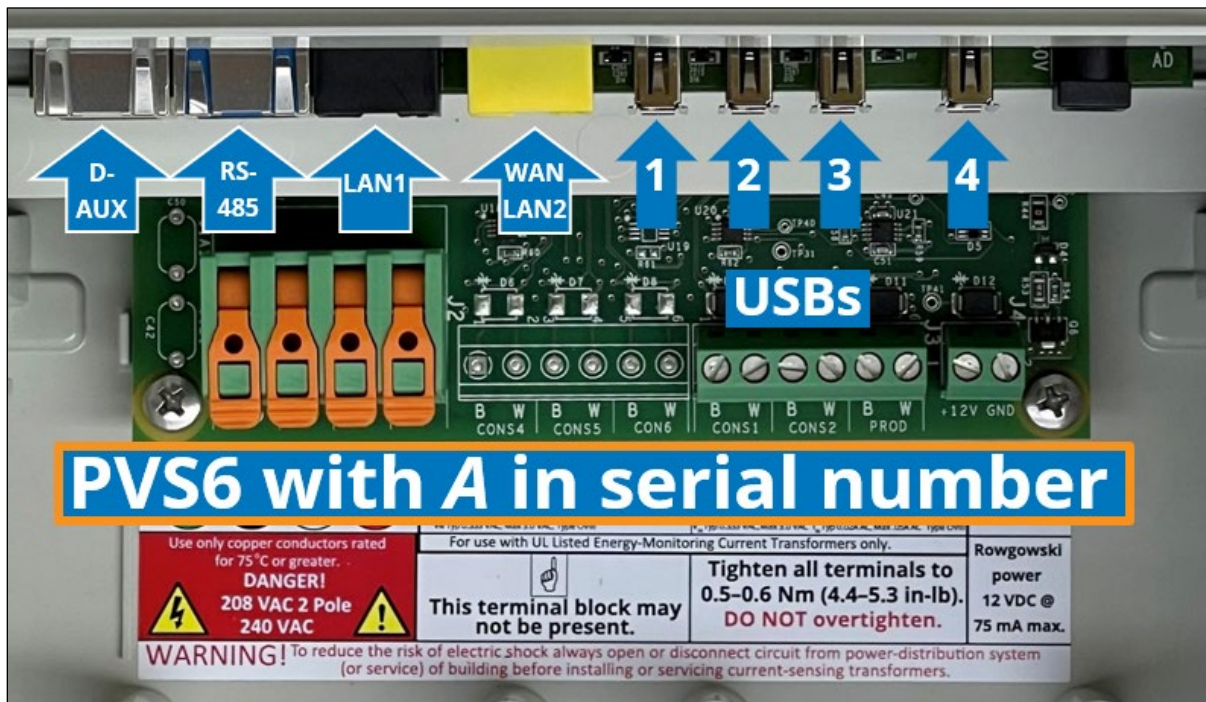

However, in PVS6 units with a **W** in their serial number, the original **LAN1** and **WAN/LAN2** ports, as well as **USB Port 1**, are no longer present:

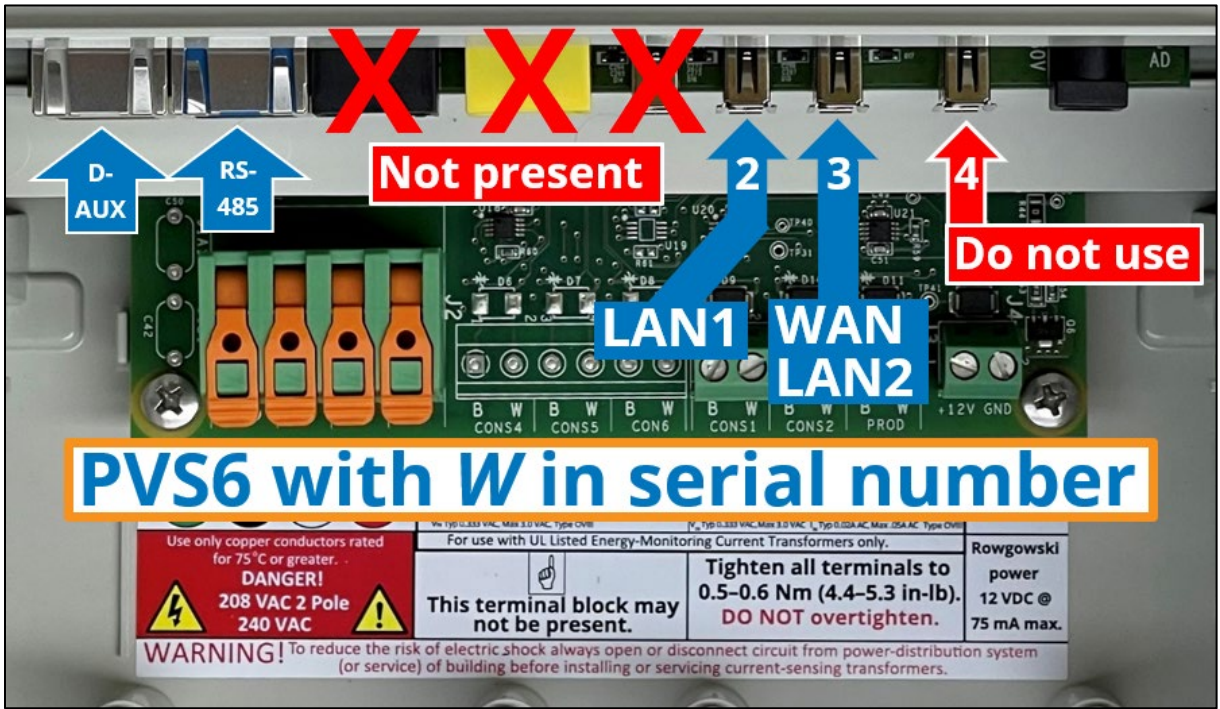

Approved Ethernet Dongles

Dealers must acquire dongles, and only the following two models may be used:

<p>Plugable USB2-E1000</p>		<p>https://plugable.com/products/usb2-e1000</p>
<p>Cable Matters 202023</p>		<p>https://www.cablematters.com/pc-489-138-usb-20-to-fast-ethernet-adapter.aspx</p>

No other dongles are acceptable—please use **ONLY** one of these options.

Assessing Site Equipment and Dongle Use

A dongle may only be connected when the PVS6 is off. If the PVS6 is on, turn it off, plug in the appropriate dongle, and then turn the PVS6 back on.

If your PVS6 **has** the Ethernet ports (if it has an **A** in its serial number), and the WiFi signal is strong, you may commission via WiFi, which does not require a dongle.

If your PVS6 **lacks** the Ethernet ports (if it has a **W** in its serial number), you must first assess the existing site equipment to determine dongle applicability.

If the site only has an Equinox system:

For a PVS6 that has a **W** in its serial number, and no SunVault system is present, no dongle will be present from the factory:

- If the WiFi signal is strong you may commission via WiFi (as you normally would when you have a strong signal).
- If the WiFi signal is weak, you must use an Ethernet cable:
 1. Plug the USB end of a dongle into **Port 3** (WAN/LAN2) on the PVS6.
 2. Plug an Ethernet cable into the other end of the dongle.
 3. Plug the other end of the Ethernet cable into the customer's router.

If the site has both an Equinox and a SunVault system:

In all SunVault installations the PVS6 is integrated into the Hub+ and one dongle will be preinstalled in **Port 2** (LAN1) by the factory:

- INDEPENDENT OF THE STRENGTH OR WEAKNESS OF THE WIFI SIGNAL:
 1. Plug an Ethernet cable into the dongle that's connected to **Port 2** (LAN1) on the PVS6.
 2. Plug the other end of the Ethernet cable into the **Ethernet** port on the gateway in the BASE ESS enclosure.
- If the WiFi signal is weak:
 1. Plug the USB end of a *second* dongle into **Port 3** (WAN/LAN2) on the PVS6.
 2. Plug an Ethernet cable into the other end of the dongle.
 3. Plug the other end of the Ethernet cable into the customer's router.

Connecting the PVS6

If your PVS6 **has** the Ethernet ports (**A** in serial number), there are **no changes** to the instructions in the *PVS6 Installation Quick Start Guide (QSG) 531566*. You use this QSG to complete installation of an Equinox-only (standalone) PVS6 and commissioning of the Equinox system.

If your PVS6 **lacks** the Ethernet ports (**W** in serial number), and it is **not** integrated into a SunVault Hub+: when you are ready to complete the PVS6 installation and commission the system, **you must perform slight variations to the existing instructions in the PVS6 QSG:**

- If your PVS6 lacks the Ethernet ports, when you reach **Step 7** in the QSG, if an SMA US-40 inverter is present, connect the dongle to the Ethernet cable, and then plug the dongle into the **Port 2** (LAN1) on the PVS6.
- If your PVS6 lacks the Ethernet ports, when you reach **Step 8** in the QSG, if you are using an Ethernet cable to connect to the internet, connect the dongle to the Ethernet cable, and then plug the dongle into the **Port 3** (WAN/LAN2) on the PVS6.

Completing the PVS6 Installation

When you have appropriately connected cables and are ready to complete the PVS6 installation and commission, use the *PVS6 Installation Quick Start Guide (QSG) 531566*.

Because the PVS6 would be integrated into the SunVault Hub+, the Quick Start Guide is not applicable to SunVault installations.

If you have any questions, please contact us at 1.855.977.7867 or TechnicalSupport@sunpowercorp.com.

Thank you for helping us change the way our world is powered.