

## FCC Test Report (WLAN)

**Report No.:** RF180803E05A-1

**FCC ID:** HD5-PVS6

**Test Model:** PVS6

**Received Date:** Sep. 04, 2018

**Test Date:** Oct. 20 to 30, 2018

**Issued Date:** Dec. 10, 2018

**Applicant:** SunPower Corporation

**Address:** 1414 Harbour Way South Suite 1901, Richmond, CA 94804, USA

**Issued By:** Bureau Veritas Consumer Products Services (H.K.) Ltd., Taoyuan Branch  
Hsin Chu Laboratory

**Lab Address:** E-2, No.1, Li Hsin 1st Road, Hsinchu Science Park, Hsinchu City 300,  
Taiwan R.O.C.

**Test Location :** E-2, No.1, Li Hsin 1st Road, Hsinchu Science Park, Hsinchu City 300,  
Taiwan R.O.C.

**FCC Registration /  
Designation Number:** 723255 / TW2022



This report is for your exclusive use. Any copying or replication of this report to or for any other person or entity, or use of our name or trademark, is permitted only with our prior written permission. This report sets forth our findings solely with respect to the test samples identified herein. The results set forth in this report are not indicative or representative of the quality or characteristics of the lot from which a test sample was taken or any similar or identical product unless specifically and expressly noted. Our report includes all of the tests requested by you and the results thereof based upon the information that you provided to us. You have 60 days from date of issuance of this report to notify us of any material error or omission caused by our negligence, provided, however, that such notice shall be in writing and shall specifically address the issue you wish to raise. A failure to raise such issue within the prescribed time shall constitute your unqualified acceptance of the completeness of this report, the tests conducted and the correctness of the report contents. Unless specific mention, the uncertainty of measurement has been explicitly taken into account to declare the compliance or non-compliance to the specification. The report must not be used by the client to claim product certification, approval, or endorsement by TAF or any government agencies.

## Table of Contents

<b>Release Control Record</b> .....	<b>4</b>
<b>1 Certificate of Conformity</b> .....	<b>5</b>
<b>2 Summary of Test Results</b> .....	<b>6</b>
2.1 Measurement Uncertainty .....	6
2.2 Modification Record .....	6
<b>3 General Information</b> .....	<b>7</b>
3.1 General Description of EUT (WLAN) .....	7
3.2 Description of Test Modes .....	10
3.2.1 Test Mode Applicability and Tested Channel Detail .....	11
3.3 Duty Cycle of Test Signal .....	13
3.4 Description of Support Units .....	14
3.4.1 Configuration of System under Test .....	14
3.5 General Description of Applied Standard .....	15
<b>4 Test Types and Results</b> .....	<b>16</b>
4.1 Radiated Emission and Bandedge Measurement .....	16
4.1.1 Limits of Radiated Emission and Bandedge Measurement .....	16
4.1.2 Test Instruments .....	17
4.1.3 Test Procedure .....	19
4.1.4 Deviation from Test Standard .....	19
4.1.5 Test Setup .....	20
4.1.6 EUT Operating Condition .....	21
4.1.7 Test Results .....	22
4.2 Conducted Emission Measurement .....	42
4.2.1 Limits of Conducted Emission Measurement .....	42
4.2.2 Test Instruments .....	42
4.2.3 Test Procedures .....	43
4.2.4 Deviation from Test Standard .....	43
4.2.5 Test Setup .....	43
4.2.6 EUT Operating Conditions .....	43
4.2.7 Test Results .....	44
4.3 Transmit Power Measurement .....	46
4.3.1 Limits of Transmit Power Measurement .....	46
4.3.2 Test Setup .....	46
4.3.3 Test Instruments .....	46
4.3.4 Test Procedure .....	46
4.3.5 Deviation from Test Standard .....	46
4.3.6 EUT Operating Condition .....	46
4.3.7 Test Result (Mode 1) .....	47
4.3.8 Test Result (Mode 2) .....	49
4.3.9 Test Result .....	50
4.4 Occupied Bandwidth Measurement .....	51
4.4.1 Test Setup .....	51
4.4.2 Test Instruments .....	51
4.4.3 Test Procedure .....	51
4.4.4 Test Results .....	52
4.5 Peak Power Spectral Density Measurement .....	57
4.5.1 Limits of Peak Power Spectral Density Measurement .....	57
4.5.2 Test Setup .....	57
4.5.3 Test Instruments .....	57
4.5.4 Test Procedure .....	57
4.5.5 Deviation from Test Standard .....	58
4.5.6 EUT Operating Condition .....	58
4.5.7 Test Results .....	59

4.6	Frequency Stability Measurement.....	65
4.6.1	Limits of Frequency Stability Measurement .....	65
4.6.2	Test Setup.....	65
4.6.3	Test Instruments .....	65
4.6.4	Test Procedure .....	65
4.6.5	Deviation from Test Standard .....	65
4.6.6	EUT Operating Condition .....	65
4.6.7	Test Results .....	66
4.7	6dB Bandwidth Measurement.....	67
4.7.1	Limits of 6dB Bandwidth Measurement.....	67
4.7.2	Test Setup.....	67
4.7.3	Test Instruments .....	67
4.7.4	Test Procedure .....	67
4.7.5	Deviation from Test Standard .....	67
4.7.6	EUT Operating Condition .....	67
4.7.7	Test Results .....	68
<b>5</b>	<b>Pictures of Test Arrangements.....</b>	<b>70</b>
	<b>Annex A- Radiated Out of Band Emission (OOBE) Measurement (For U-NII-3 band).....</b>	<b>71</b>
	<b>Appendix – Information on the Testing Laboratories.....</b>	<b>74</b>

### Release Control Record

Issue No.	Description	Date Issued
RF180803E05A-1	Original release.	Dec. 10, 2018

## 1 Certificate of Conformity

**Product:** SunPower Monitoring System with PVS6

**Brand:** SUNPOWER

**Test Model:** PVS6

**Sample Status:** ENGINEERING SAMPLE

**Applicant:** SunPower Corporation

**Test Date:** Oct. 20 to 30, 2018

**Standard:** 47 CFR FCC Part 15, Subpart E (Section 15.407)  
ANSI C63.10: 2013

The above equipment has been tested by **Bureau Veritas Consumer Products Services (H.K.) Ltd., Taoyuan Branch**, and found compliance with the requirement of the above standards. The test record, data evaluation & Equipment Under Test (EUT) configurations represented herein are true and accurate accounts of the measurements of the sample's EMC characteristics under the conditions specified in this report.

**Prepared by :**  \_\_\_\_\_, **Date:** \_\_\_\_\_ Dec. 10, 2018  
Claire Kuan / Specialist

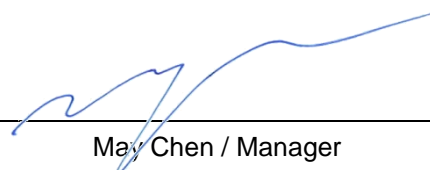
**Approved by :**  \_\_\_\_\_, **Date:** \_\_\_\_\_ Dec. 10, 2018  
May Chen / Manager

## 2 Summary of Test Results

47 CFR FCC Part 15, Subpart E (Section 15.407)			
FCC Clause	Test Item	Result	Remarks
15.407(b)(6)	AC Power Conducted Emissions	PASS	Meet the requirement of limit. Minimum passing margin is -4.96dB at 10.46094MHz.
15.407(b) (1/2/3/4(i/ii)/6)	Radiated Emissions & Band Edge Measurement*	Pass	Meet the requirement of limit. Minimum passing margin is -0.2dB at 5150.00MHz.
15.407(a)(1/2/3)	Max Average Transmit Power	Pass	Meet the requirement of limit.
---	Occupied Bandwidth Measurement	-	Reference only.
15.407(a)(1/2/3)	Peak Power Spectral Density	Pass	Meet the requirement of limit.
15.407(e)	6dB bandwidth	Pass	Meet the requirement of limit. (U-NII-3 Band only)
15.407(g)	Frequency Stability	Pass	Meet the requirement of limit.
15.203	Antenna Requirement	PASS	Antenna connector is I-PEX not a standard connector.

\*For U-NII-3 band compliance with rule part 15.407(b)(4)(i), the OOB test plots were recorded in Annex A.

### 2.1 Measurement Uncertainty

Where relevant, the following measurement uncertainty levels have been estimated for tests performed on the EUT as specified in CISPR 16-4-2:

Measurement	Frequency	Expanded Uncertainty (k=2) (±)
Conducted Emissions at mains ports	150kHz ~ 30MHz	1.84 dB
Radiated Emissions up to 1 GHz	30MHz ~ 1GHz	5.53 dB
Radiated Emissions above 1 GHz	1GHz ~ 6GHz	5.08 dB
	6GHz ~ 18GHz	4.98 dB
	18GHz ~ 40GHz	5.19 dB

### 2.2 Modification Record

There were no modifications required for compliance.

### 3 General Information

#### 3.1 General Description of EUT (WLAN)

Product	SunPower Monitoring System with PVS6
Brand	SUNPOWER
Test Model	PVS6
Status of EUT	ENGINEERING SAMPLE
Power Supply Rating	AC100-240V, 0.75A , 50/60Hz
Modulation Type	CCK, DQPSK, DBPSK for DSSS 64QAM, 16QAM, QPSK, BPSK for OFDM 256QAM for OFDM in 11ac mode
Modulation Technology	DSSS,OFDM
Transfer Rate	802.11b: up to 11Mbps 802.11a/g: up to 54Mbps 802.11n: up to 300Mbps 802.11ac: up to 866.7Mbps
Operating Frequency	<b>2.4GHz:</b> 2.412 ~ 2.462GHz <b>5GHz:</b> 5.18 ~ 5.24GHz, 5.745 ~ 5.825GHz
Number of Channel	<b>2.4GHz:</b> 802.11b, 802.11g, 802.11n (HT20), VHT20: 11 <b>5GHz:</b> 802.11a, 802.11n (HT20), 802.11ac (VHT20): 9 802.11n (HT40), 802.11ac (VHT40): 4 802.11ac (VHT80): 2
Output Power	<b>2.4GHz:</b> 762.15mW <b>5GHz:</b> <b>5.18 ~ 5.24GHz:</b> 199.38mW <b>5.745 ~ 5.825GHz:</b> 268.355mW
Antenna Type	Refer to Note
Antenna Connector	Refer to Note
Accessory Device	Hole Plugs x 2 Bracket
Data Cable Supplied	Ethernet cable (Unshielded, 1.5m)

Note:

- There are WLAN, Bluetooth, Zigbee and WWAN technology used for the EUT. The EUT has three radios as following table:

Radio 1	Radio 2	Radio 3	Radio 4
WLAN (2.4GHz+5GHz)	Zigbee	BT	WWAN (LTE+GSM)

- Simultaneously transmission condition.

Condition	Technology			
1	WLAN(2.4GHz)	BT	Zigbee	WWAN
2	WLAN(5GHz)	BT	Zigbee	WWAN

**Note:** The emission of the simultaneous operation has been evaluated and no non-compliance was found.

- The EUT needs to be supplied from an Internal power supply, the information is as below table:

Brand	Model No.	Spec.
WLAN WELL	IRM-30-12	AC Input: 100-240V, 0.75A , 50/60Hz DC Output: 12V, 2.5A

4. The antennas provided to the EUT, please refer to the following table:

WLAN							
Ant No.	Chain No.	Brand	Model	Antenna Net Gain (dBi)	Frequency rang (GHz)	Antenna type	Connector type
1	Chain 0 (Including BT)	airgain	65-031-212002B	2.2	2.4~2.4835	PCB	I-PEX
				3.8	5.15~5.25		
				4.2	5.725~5.85		
2	Chain 1 (WLAN use only)	airgain	65-031-212003B	4.2	2.4~2.4835	PCB	I-PEX
				4.1	5.15~5.25		
				4.8	5.725~5.85		
Zigbee							
Ant No.	Brand	Model	Antenna Gain (dBi)	Frequency rang (GHz)	Antenna type	Connector type	
3	airgain	65-031-212004B	4.8	2.4~2.4835	PCB	I-PEX	
LTE							
Ant No.	Brand	Model	Antenna Gain (dBi)	Frequency rang (MHz)	Antenna type	Connector type	
4	airgain	65-031-212001B	2.7	1920~1980	PCB	I-PEX	
				1850~1910			
				1710~1785			
				1710~1755			
				824 ~ 849			
				880~915			
				698~716			
				777~787			
				815 ~ 830			
				830 ~ 845			
				832 ~ 862			
				814 ~ 849			
				703 ~ 748			
1880 ~ 1920							



5. The EUT incorporates a MIMO function.

2.4GHz Band			
MODULATION MODE	DATA RATE (MCS)	TX & RX CONFIGURATION	
802.11b	1 ~ 11Mbps	2TX	2RX
802.11g	6 ~ 54Mbps	2TX	2RX
802.11n (HT20)	MCS 0~7	2TX	2RX
	MCS 8~15	2TX	2RX
5GHz Band			
MODULATION MODE	DATA RATE (MCS)	TX & RX CONFIGURATION	
802.11a	6 ~ 54Mbps	2TX	2RX
802.11n (HT20)	MCS 0~7	2TX	2RX
	MCS 8~15	2TX	2RX
802.11n (HT40)	MCS 0~7	2TX	2RX
	MCS 8~15	2TX	2RX
802.11ac (VHT20)	MCS0~8 Nss=1	2TX	2RX
	MCS0~8 Nss=2	2TX	2RX
802.11ac (VHT40)	MCS0~9 Nss=1	2TX	2RX
	MCS0~9 Nss=2	2TX	2RX
802.11ac (VHT80)	MCS0~9 Nss=1	2TX	2RX
	MCS0~9 Nss=2	2TX	2RX

6. This device can support different category application which switched by access point mode and client mode by software.

7. The EUT will install at outdoor area, for U-NII-1 the highest antenna gain is 1.49dBi from the horizon above 30 degrees, for more detail information please refer to antenna specification and user manual.

8. The power setting are list as below:

Master Mode				
Modulation Mode	Frequency (MHz)	Power Setting	Frequency (MHz)	Power Setting
802.11a	5180	63	5745	88
	5200	63	5785	88
	5240	63	5825	88
802.11ac (VHT20)	5180	64	5745	88
	5200	64	5785	88
	5240	64	5825	88
802.11ac (VHT40)	5190	55	5755	83
	5230	68	5795	88
802.11ac (VHT80)	5210	48	5775	68
Client Mode				
Modulation Mode	Frequency (MHz)		Power Setting	
802.11a	5180		67	
	5200		73	
	5240		78	
802.11ac (VHT20)	5180		66	
	5200		73	
	5240		78	
802.11ac (VHT40)	5190		55	
	5230		72	
802.11ac (VHT80)	5210		48	

9. The above EUT information is declared by manufacturer and for more detailed features description, please refer to the manufacturer's specifications or user's manual.

### 3.2 Description of Test Modes

#### FOR 5180 ~ 5240MHz

4 channels are provided for 802.11a, 802.11n (HT20), 802.11ac (VHT20):

Channel	Frequency	Channel	Frequency
36	5180 MHz	44	5220 MHz
40	5200 MHz	48	5240 MHz

2 channels are provided for 802.11n (HT40), 802.11ac (VHT40):

Channel	Frequency	Channel	Frequency
38	5190 MHz	46	5230 MHz

1 channel is provided for 802.11ac (VHT80):

Channel	Frequency
42	5210 MHz

#### FOR 5745 ~ 5825MHz:

5 channels are provided for 802.11a, 802.11n (HT20), 802.11ac (VHT20):

Channel	Frequency	Channel	Frequency
149	5745 MHz	161	5805 MHz
153	5765 MHz	165	5825 MHz
157	5785 MHz		

2 channels are provided for 802.11n (HT40), 802.11ac (VHT40):

Channel	Frequency	Channel	Frequency
151	5755 MHz	159	5795 MHz

1 channel is provided for 802.11ac (VHT80):

Channel	Frequency
155	5775 MHz

### 3.2.1 Test Mode Applicability and Tested Channel Detail

EUT Configure Mode	Applicable To				Description
	RE $\geq$ 1G	RE<1G	PLC	APCM	
1	-	-	-	√ (Note 1)	Master mode (Only U-NII 1)
2	-	-	-	√ (Note 1)	Client mode (Only U-NII 1)
-	√	√	√	√ (Note 2)	Worsr case for Master and Client mode

Where **RE $\geq$ 1G**: Radiated Emission above 1GHz      **RE<1G**: Radiated Emission below 1GHz  
**PLC**: Power Line Conducted Emission      **APCM**: Antenna Port Conducted Measurement

NOTE:

1. For transmit power measurement.
2. For other test items.

#### **Radiated Emission Test (Above 1GHz):**

- Pre-Scan has been conducted to determine the worst-case mode from all possible combinations between available modulations, data rates and antenna ports (if EUT with antenna diversity architecture).
- Following channel(s) was (were) selected for the final test as listed below.

EUT Configure Mode	Mode	FREQ. Band (MHz)	Available Channel	Tested Channel	Modulation Technology	Modulation Type	Data Rate (Mbps)
-	802.11a	5180-5240	36 to 48	36, 40, 48	OFDM	BPSK	6
	802.11ac (VHT20)		36 to 48	36, 40, 48	OFDM	BPSK	6.5
	802.11ac (VHT40)		38 to 46	38, 46	OFDM	BPSK	13.5
	802.11ac (VHT80)		42	42	OFDM	BPSK	29.3
-	802.11a	5745-5825	149 to 165	149, 157, 165	OFDM	BPSK	6
	802.11ac (VHT20)		149 to 165	149, 157, 165	OFDM	BPSK	6.5
	802.11ac (VHT40)		151 to 159	151, 159	OFDM	BPSK	13.5
	802.11ac (VHT80)		155	155	OFDM	BPSK	29.3

#### **Radiated Emission Test (Below 1GHz):**

- Pre-Scan has been conducted to determine the worst-case mode from all possible combinations between available modulations, data rates and antenna ports (if EUT with antenna diversity architecture).
- Following channel(s) was (were) selected for the final test as listed below.

EUT Configure Mode	Mode	FREQ. Band (MHz)	Available Channel	Tested Channel	Modulation Technology	Modulation Type	Data Rate (Mbps)
-	802.11ac (VHT20)	5180-5240 5745-5825	36 to 48 149 to 165	149	OFDM	BPSK	6.5

### Power Line Conducted Emission Test:

- Pre-Scan has been conducted to determine the worst-case mode from all possible combinations between available modulations, data rates and antenna ports (if EUT with antenna diversity architecture).
- Following channel(s) was (were) selected for the final test as listed below.

EUT Configure Mode	Mode	FREQ. Band (MHz)	Available Channel	Tested Channel	Modulation Technology	Modulation Type	Data Rate (Mbps)
-	802.11ac (VHT20)	5180-5240 5745-5825	36 to 48 149 to 165	149	OFDM	BPSK	6.5

### Antenna Port Conducted Measurement:

- This item includes all test value of each mode, but only includes spectrum plot of worst value of each mode.
- Pre-Scan has been conducted to determine the worst-case mode from all possible combinations between available modulations, data rates and antenna ports (if EUT with antenna diversity architecture).
- Following channel(s) was (were) selected for the final test as listed below.

For Transmit Power Measurement							
EUT Configure Mode	Mode	FREQ. Band (MHz)	Available Channel	Tested Channel	Modulation Technology	Modulation Type	Data Rate (Mbps)
1, 2	802.11a	5180-5240	36 to 48	36, 40, 48	OFDM	BPSK	6
	802.11ac (VHT20)		36 to 48	36, 40, 48	OFDM	BPSK	6.5
	802.11ac (VHT40)		38 to 46	38, 46	OFDM	BPSK	13.5
	802.11ac (VHT80)		42	42	OFDM	BPSK	29.3
-	802.11a	5745-5825	149 to 165	149, 157, 165	OFDM	BPSK	6
	802.11ac (VHT20)		149 to 165	149, 157, 165	OFDM	BPSK	6.5
	802.11ac (VHT40)		151 to 159	151, 159	OFDM	BPSK	13.5
	802.11ac (VHT80)		155	155	OFDM	BPSK	29.3
For other test							
EUT Configure Mode	Mode	FREQ. Band (MHz)	Available Channel	Tested Channel	Modulation Technology	Modulation Type	Data Rate (Mbps)
-	802.11a	5180-5240	36 to 48	36, 40, 48	OFDM	BPSK	6
	802.11ac (VHT20)		36 to 48	36, 40, 48	OFDM	BPSK	6.5
	802.11ac (VHT40)		38 to 46	38, 46	OFDM	BPSK	13.5
	802.11ac (VHT80)		42	42	OFDM	BPSK	29.3
-	802.11a	5745-5825	149 to 165	149, 157, 165	OFDM	BPSK	6
	802.11ac (VHT20)		149 to 165	149, 157, 165	OFDM	BPSK	6.5
	802.11ac (VHT40)		151 to 159	151, 159	OFDM	BPSK	13.5
	802.11ac (VHT80)		155	155	OFDM	BPSK	29.3

### Test Condition:

APPLICABLE TO	ENVIRONMENTAL CONDITIONS	INPUT POWER	TESTED BY
RE≥1G	22deg. C, 66%RH	120Vac, 60Hz	Frank Chuang
RE<1G	23deg. C, 67%RH	120Vac, 60Hz	Frank Chuang
PLC	25deg. C, 75%RH	120Vac, 60Hz	Andy Ho
APCM	25deg. C, 60%RH	120Vac, 60Hz	Jyunchun Lin

### 3.3 Duty Cycle of Test Signal

If duty cycle of test signal is < 98%, duty factor shall be considered.

**802.11a:** Duty cycle = 1.393 ms/1.513 ms = 0.921, Duty factor =  $10 * \log(1/0.921) = 0.36$

**802.11ac (VHT20):** Duty cycle = 1.313 ms/1.427 ms = 0.92, Duty factor =  $10 * \log(1/0.92) = 0.36$

**802.11ac (VHT40):** Duty cycle = 0.655 ms/0.758 ms = 0.864 Duty factor =  $10 * \log(1/0.864) = 0.63$

**802.11ac (VHT80):** Duty cycle = 0.322 ms/0.428 ms = 0.752, Duty factor =  $10 * \log(1/0.752) = 1.24$

**802.11a**

**802.11ac (VHT20)**

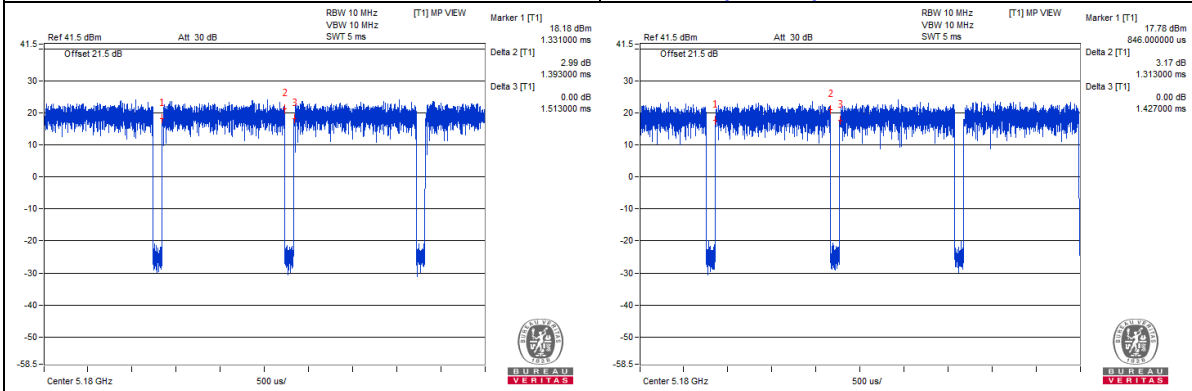

**802.11ac (VHT40)**

**802.11ac (VHT80)**

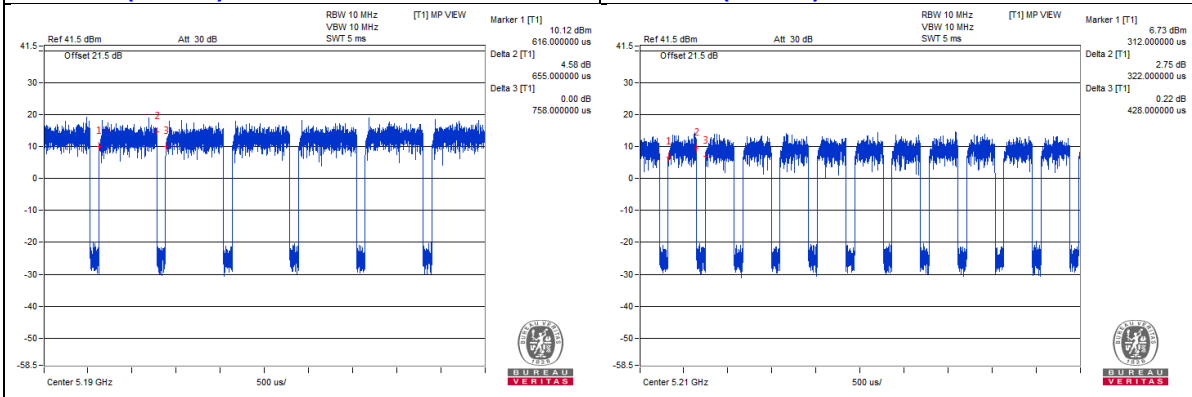

### 3.4 Description of Support Units

The EUT has been tested as an independent unit together with other necessary accessories or support units. The following support units or accessories were used to form a representative test configuration during the tests.

ID	Product	Brand	Model No.	Serial No.	FCC ID	Remarks
A.	iPod	Apple	MC749TA/A	CC4DMFJUDFDM	NA	Provided by Lab
B.	Laptop	Lenovo	81A4	YD02YN22	NA	Provided by Lab

Note:

1. All power cords of the above support units are non-shielded (1.8m).

ID	Descriptions	Qty.	Length (m)	Shielding (Yes/No)	Cores (Qty.)	Remarks
1.	AC Cable	1	1.8	No	0	Supplied by client
2.	RJ-45 Cable	1	10	No	0	Provided by Lab
3.	USB Cable	1	0.1	Yes	0	Provided by Lab

Note: The core(s) is(are) originally attached to the cable(s).

#### 3.4.1 Configuration of System under Test

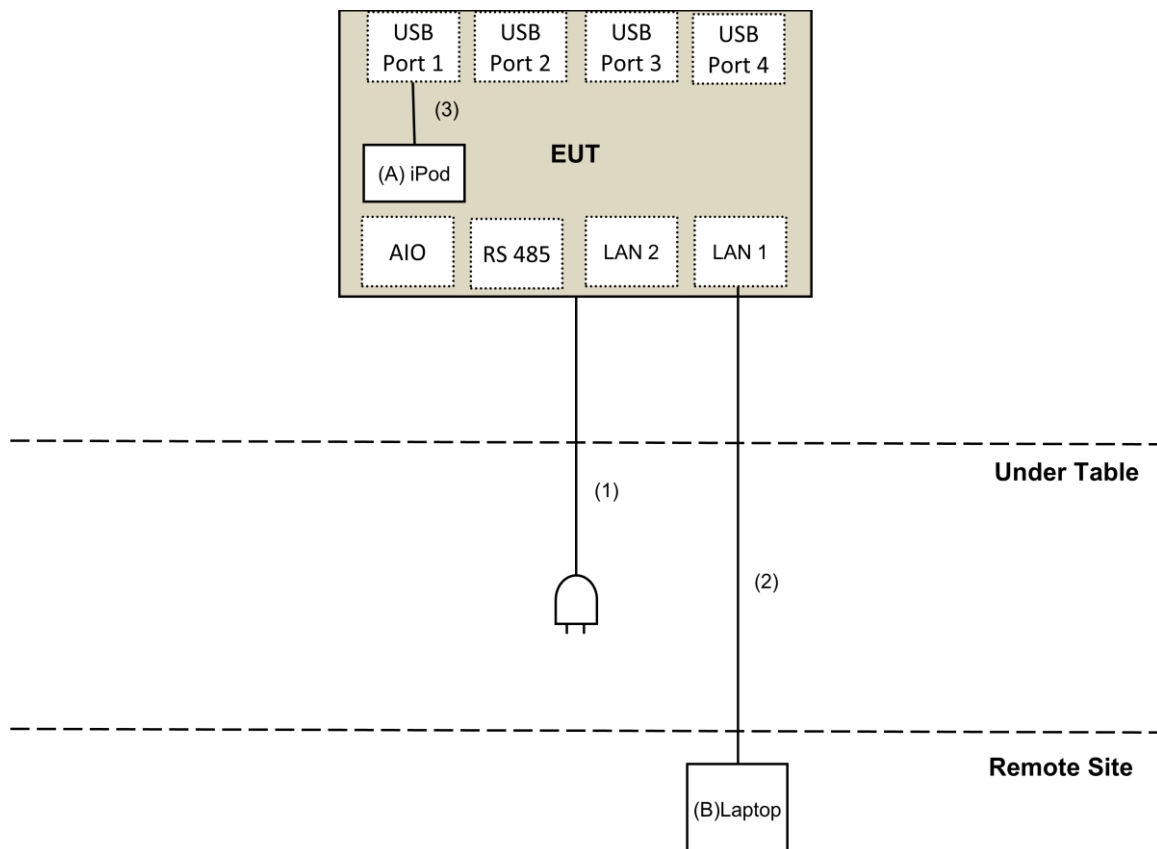

### 3.5 General Description of Applied Standard

The EUT is a RF Product. According to the specifications of the manufacturer, it must comply with the requirements of the following standards:

**FCC Part 15, Subpart E (15.407)**

**KDB 789033 D02 General UNII Test Procedure New Rules v02r01**

**KDB 662911 D01 Multiple Transmitter Output v02r01**

**ANSI C63.10-2013**

All test items have been performed and recorded as per the above standards.

## 4 Test Types and Results

### 4.1 Radiated Emission and Bandedge Measurement

#### 4.1.1 Limits of Radiated Emission and Bandedge Measurement

Radiated emissions which fall in the restricted bands must comply with the radiated emission limits specified as below table.

Frequencies (MHz)	Field Strength (microvolts/meter)	Measurement Distance (meters)
0.009 ~ 0.490	2400/F(kHz)	300
0.490 ~ 1.705	24000/F(kHz)	30
1.705 ~ 30.0	30	30
30 ~ 88	100	3
88 ~ 216	150	3
216 ~ 960	200	3
Above 960	500	3

#### NOTE:

- The lower limit shall apply at the transition frequencies.
- Emission level (dBuV/m) = 20 log Emission level (uV/m).
- For frequencies above 1000MHz, the field strength limits are based on average detector, however, the peak field strength of any emission shall not exceed the maximum permitted average limits, specified above by more than 20dB under any condition of modulation.

Limits of unwanted emission out of the restricted bands

Applicable To		Limit	
789033 D02 General UNII Test Procedure New Rules v02r01		Field Strength at 3m	
		PK:74 (dBuV/m)	AV:54 (dBuV/m)
Frequency Band	Applicable To	EIRP Limit	Equivalent Field Strength at 3m
5150~5250 MHz	15.407(b)(1)	PK:-27 (dBm/MHz)	PK:68.2(dBuV/m)
5250~5350 MHz	15.407(b)(2)		
5470~5725 MHz	15.407(b)(3)		
5725~5850 MHz	<input checked="" type="checkbox"/> 15.407(b)(4)(i)	PK:-27 (dBm/MHz) <sup>*1</sup> PK:10 (dBm/MHz) <sup>*2</sup> PK:15.6 (dBm/MHz) <sup>*3</sup> PK:27 (dBm/MHz) <sup>*4</sup>	PK: 68.2(dBuV/m) <sup>*1</sup> PK:105.2 (dBuV/m) <sup>*2</sup> PK: 110.8(dBuV/m) <sup>*3</sup> PK:122.2 (dBuV/m) <sup>*4</sup>
	<input type="checkbox"/> 15.407(b)(4)(ii)	Emission limits in section 15.247(d)	
<sup>*1</sup> beyond 75 MHz or more above of the band edge.		<sup>*2</sup> below the band edge increasing linearly to 10 dBm/MHz at 25 MHz above.	
<sup>*3</sup> below the band edge increasing linearly to a level of 15.6 dBm/MHz at 5 MHz above.		<sup>*4</sup> from 5 MHz above or below the band edge increasing linearly to a level of 27 dBm/MHz at the band edge.	

#### Note:

The following formula is used to convert the equipment isotropic radiated power (eirp) to field strength:

$$E = \frac{1000000\sqrt{30P}}{3} \mu\text{V/m, where P is the eirp (Watts).}$$



## 4.1.2 Test Instruments

DESCRIPTION & MANUFACTURER	MODEL NO.	SERIAL NO.	CALIBRATED DATE	CALIBRATED UNTIL
Test Receiver Agilent	N9038A	MY50010156	July 12, 2018	July 11, 2019
Pre-Amplifier EMCI	EMC001340	980142	Feb. 09, 2018	Feb. 08, 2019
Loop Antenna(*) Electro-Metrics	EM-6879	264	Dec. 16, 2016	Dec. 15, 2018
RF Cable	NA	LOOPCAB-001	Jan. 15, 2018	Jan. 14, 2019
RF Cable	NA	LOOPCAB-002	Jan. 15, 2018	Jan. 14, 2019
Pre-Amplifier Mini-Circuits	ZFL-1000VH2B	AMP-ZFL-05	May 05, 2018	May 04, 2019
Trilog Broadband Antenna SCHWARZBECK	VULB 9168	9168-361	Nov. 29, 2017	Nov. 28, 2018
RF Cable	8D	966-3-1	Mar. 20, 2018	Mar. 19, 2019
RF Cable	8D	966-3-2	Mar. 20, 2018	Mar. 19, 2019
RF Cable	8D	966-3-3	Mar. 20, 2018	Mar. 19, 2019
Fixed attenuator Mini-Circuits	UNAT-5+	PAD-3m-3-01	Sep. 27, 2018	Sep. 26, 2019
Horn_Antenna SCHWARZBECK	BBHA9120-D	9120D-406	Dec. 12, 2017	Dec. 11, 2018
Pre-Amplifier EMCI	EMC12630SE	980384	Jan. 29, 2018	Jan. 28, 2019
RF Cable	EMC104-SM-SM-1200	160922	Jan. 29, 2018	Jan. 28, 2019
RF Cable	EMC104-SM-SM-2000	150317	Jan. 29, 2018	Jan. 28, 2019
RF Cable	EMC104-SM-SM-5000	150322	Jan. 29, 2018	Jan. 28, 2019
Spectrum Analyzer Keysight	N9030A	MY54490679	July 23, 2018	July 22, 2019
Pre-Amplifier EMCI	EMC184045SE	980386	Jan. 29, 2018	Jan. 28, 2019
Horn_Antenna SCHWARZBECK	BBHA 9170	BBHA9170608	Dec. 14, 2017	Dec. 13, 2018
RF Cable	EMC102-KM-KM-1200	160924	Jan. 29, 2018	Jan. 28, 2019
Software	ADT_Radiated_V8.7.08	NA	NA	NA
Antenna Tower & Turn Table Max-Full	MF-7802	MF780208406	NA	NA
Boresight Antenna Fixture	FBA-01	FBA-SIP01	NA	NA
Spectrum Analyzer R&S	FSV40	100964	June 20, 2018	June 19, 2019
Power meter Anritsu	ML2495A	1014008	May 09, 2018	May 08, 2019
Power sensor Anritsu	MA2411B	0917122	May 09, 2018	May 08, 2019
AC Power Source Extech Electronics	6205	1440452	NA	NA
DC Power Supply Topward	6603D	795558	NA	NA
Temperature & Humidity Chamber Giant Force	GTH-150-40-SP-AR	MAA0812-008	Jan. 10, 2018	Jan. 09, 2019
True RMS Clamp Meter FLUKE	325	31130711WS	May 22, 2018	May 21, 2019

**Note:**

1. The calibration interval of the above test instruments is 12 months and the calibrations are traceable to NML/ROC and NIST/USA.
2. \*The calibration interval of the above test instruments is 24 months and the calibrations are traceable to NML/ROC and NIST/USA.
3. The test was performed in 966 Chamber No. 3.
4. The CANADA Site Registration No. is 20331-1
5. Loop antenna was used for all emissions below 30 MHz.
6. Tested Date: Oct. 25 to 30, 2018

#### 4.1.3 Test Procedure

##### **For Radiated emission below 30MHz**

- a. The EUT was placed on the top of a rotating table 0.8 meters above the ground at a 3 meter chamber room. The table was rotated 360 degrees to determine the position of the highest radiation.
- b. The EUT was set 3 meters away from the interference-receiving antenna, which was mounted on the top of a variable-height antenna tower.
- c. Parallel, perpendicular, and ground-parallel orientations of the antenna are set to make the measurement.
- d. For each suspected emission, the EUT was arranged to its worst case and the rotatable table was turned from 0 degrees to 360 degrees to find the maximum reading.
- e. The test-receiver system was set to Quasi-Peak Detect Function and Specified Bandwidth with Maximum Hold Mode.

##### **NOTE:**

1. The resolution bandwidth and video bandwidth of test receiver/spectrum analyzer is 9kHz at frequency below 30MHz.

##### **For Radiated emission above 30MHz**

- a. The EUT was placed on the top of a rotating table 0.8 meters (for 30MHz ~ 1GHz) / 1.5 meters (for above 1GHz) above the ground at 3 meter chamber room for test. The table was rotated 360 degrees to determine the position of the highest radiation.
- b. The EUT was set 3 meters away from the interference-receiving antenna, which was mounted on the top of a variable-height antenna tower.
- c. The height of antenna is varied from one meter to four meters above the ground to determine the maximum value of the field strength. Both horizontal and vertical polarizations of the antenna are set to make the measurement.
- d. For each suspected emission, the EUT was arranged to its worst case and then the antenna was tuned to heights from 1 meter to 4 meters and the rotatable table was turned from 0 degrees to 360 degrees to find the maximum reading.
- e. The test-receiver system was set to quasi-peak detect function and specified bandwidth with maximum hold mode when the test frequency is below 1 GHz.
- f. The test-receiver system was set to peak and average detect function and specified bandwidth with maximum hold mode when the test frequency is above 1 GHz. If the peak reading value also meets average limit, measurement with the average detector is unnecessary.

##### **Note:**

1. The resolution bandwidth and video bandwidth of test receiver/spectrum analyzer is 120kHz for Quasi-peak detection (QP) at frequency below 1GHz.
2. The resolution bandwidth of test receiver/spectrum analyzer is 1 MHz and the video bandwidth is 3 MHz for Peak detection (PK) at frequency above 1GHz.
3. The resolution bandwidth of test receiver/spectrum analyzer is 1MHz and the video bandwidth is  $\geq 1/T$  (Duty cycle < 98%) or 10Hz (Duty cycle  $\geq 98\%$ ) for Average detection (AV) at frequency above 1GHz.
4. All modes of operation were investigated and the worst-case emissions are reported.

#### 4.1.4 Deviation from Test Standard

No deviation.

#### 4.1.5 Test Setup

##### For Radiated emission below 30MHz

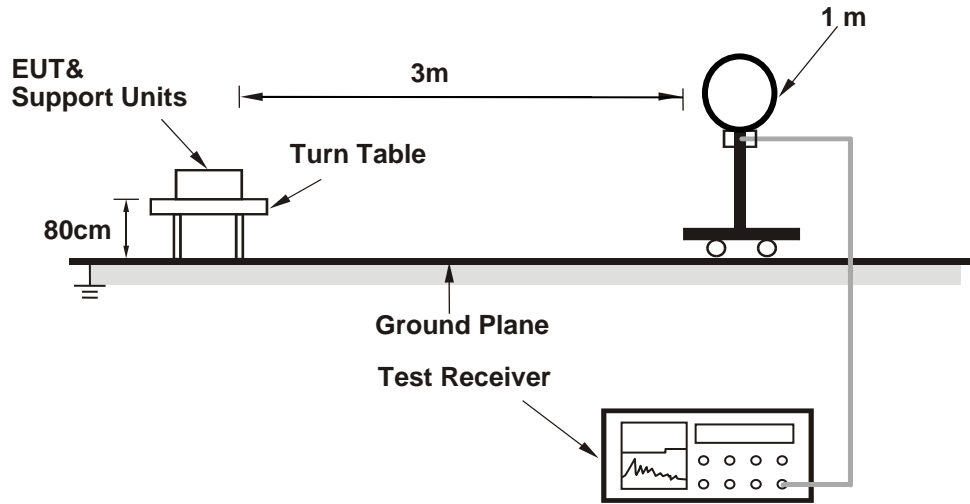

##### For Radiated emission 30MHz to 1GHz

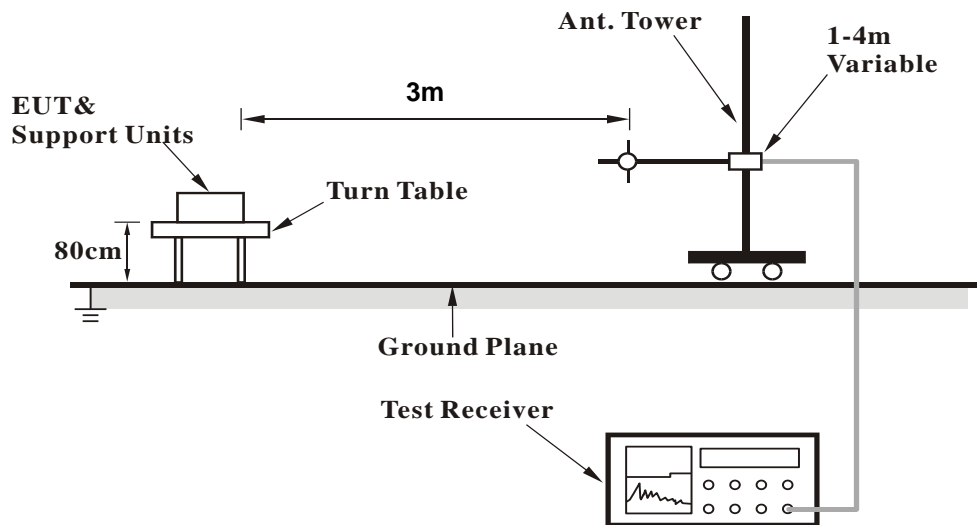

### For Radiated emission above 1GHz

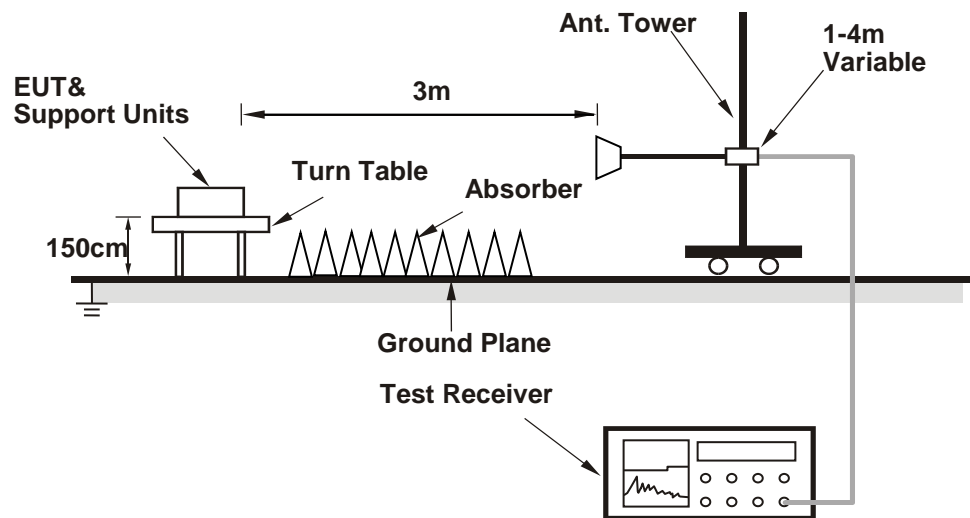

For the actual test configuration, please refer to the attached file (Test Setup Photo).

#### 4.1.6 EUT Operating Condition

- a. Placed the EUT on the testing table.
- b. Controlling software (SSH paste PVS6\_WiFi+Zigbee+BT+BLE+RB SOP.docx Command) has been activated to set the EUT on specific status.

## 4.1.7 Test Results

## Above 1GHz Data:

## 802.11a

<b>CHANNEL</b>	TX Channel 36	<b>DETECTOR FUNCTION</b>	Peak (PK)
<b>FREQUENCY RANGE</b>	1GHz ~ 40GHz		Average (AV)

**ANTENNA POLARITY & TEST DISTANCE: HORIZONTAL AT 3 M**

NO.	FREQ. (MHz)	EMISSION LEVEL (dBuV/m)	LIMIT (dBuV/m)	MARGIN (dB)	ANTENNA HEIGHT (m)	TABLE ANGLE (Degree)	RAW VALUE (dBuV)	CORRECTION FACTOR (dB/m)
1	5150.00	68.3 PK	74.0	-5.7	1.45 H	258	65.7	2.6
2	5150.00	51.3 AV	54.0	-2.7	1.45 H	258	48.7	2.6
3	*5180.00	109.5 PK			1.45 H	258	107.0	2.5
4	*5180.00	99.6 AV			1.45 H	258	97.1	2.5
5	#10360.00	48.4 PK	68.2	-19.8	1.89 H	135	36.5	11.9
6	15540.00	44.0 PK	74.0	-30.0	1.42 H	244	31.6	12.4
7	15540.00	34.7 AV	54.0	-19.3	1.42 H	244	22.3	12.4

**ANTENNA POLARITY & TEST DISTANCE: VERTICAL AT 3 M**

NO.	FREQ. (MHz)	EMISSION LEVEL (dBuV/m)	LIMIT (dBuV/m)	MARGIN (dB)	ANTENNA HEIGHT (m)	TABLE ANGLE (Degree)	RAW VALUE (dBuV)	CORRECTION FACTOR (dB/m)
1	5150.00	72.6 PK	74.0	-1.4	2.76 V	189	70.0	2.6
2	<b>5150.00</b>	<b>53.8 AV</b>	<b>54.0</b>	<b>-0.2</b>	<b>2.76 V</b>	<b>189</b>	<b>51.2</b>	<b>2.6</b>
3	*5180.00	110.4 PK			2.76 V	189	107.9	2.5
4	*5180.00	101.8 AV			2.76 V	189	99.3	2.5
5	#10360.00	48.4 PK	68.2	-19.8	1.68 V	7	36.5	11.9
6	15540.00	43.0 PK	74.0	-31.0	1.03 V	338	30.6	12.4
7	15540.00	32.5 AV	54.0	-21.5	1.03 V	338	20.1	12.4

**REMARKS:**

- Emission Level(dBuV/m) = Raw Value(dBuV) + Correction Factor(dB/m)
- Correction Factor(dB/m) = Antenna Factor(dB/m) + Cable Factor(dB) – Pre-Amplifier Factor(dB)
- The other emission levels were very low against the limit.
- Margin value = Emission Level – Limit value
- " \* ": Fundamental frequency.
- " # ": The radiated frequency is out of the restricted band.

<b>CHANNEL</b>	TX Channel 40	<b>DETECTOR FUNCTION</b>	Peak (PK)
<b>FREQUENCY RANGE</b>	1GHz ~ 40GHz		Average (AV)

**ANTENNA POLARITY & TEST DISTANCE: HORIZONTAL AT 3 M**

NO.	FREQ. (MHz)	EMISSION LEVEL (dBuV/m)	LIMIT (dBuV/m)	MARGIN (dB)	ANTENNA HEIGHT (m)	TABLE ANGLE (Degree)	RAW VALUE (dBuV)	CORRECTION FACTOR (dB/m)
1	5150.00	66.2 PK	74.0	-7.8	1.45 H	256	63.6	2.6
2	5150.00	51.1 AV	54.0	-2.9	1.45 H	256	48.5	2.6
3	*5200.00	110.7 PK			1.45 H	256	108.3	2.4
4	*5200.00	101.8 AV			1.45 H	256	99.4	2.4
5	#10400.00	50.3 PK	68.2	-17.9	1.89 H	137	38.1	12.2
6	15600.00	44.9 PK	74.0	-29.1	1.48 H	246	32.0	12.9
7	15600.00	35.8 AV	54.0	-18.2	1.48 H	246	22.9	12.9

**ANTENNA POLARITY & TEST DISTANCE: VERTICAL AT 3 M**

NO.	FREQ. (MHz)	EMISSION LEVEL (dBuV/m)	LIMIT (dBuV/m)	MARGIN (dB)	ANTENNA HEIGHT (m)	TABLE ANGLE (Degree)	RAW VALUE (dBuV)	CORRECTION FACTOR (dB/m)
1	5150.00	68.1 PK	74.0	-5.9	2.74 V	188	65.5	2.6
2	<b>5150.00</b>	<b>53.8 AV</b>	<b>54.0</b>	<b>-0.2</b>	<b>2.74 V</b>	<b>188</b>	<b>51.2</b>	<b>2.6</b>
3	*5200.00	111.7 PK			2.74 V	188	109.3	2.4
4	*5200.00	103.4 AV			2.74 V	188	101.0	2.4
5	#10400.00	50.3 PK	68.2	-17.9	1.72 V	16	38.1	12.2
6	15600.00	44.2 PK	74.0	-29.8	1.03 V	336	31.3	12.9
7	15600.00	33.6 AV	54.0	-20.4	1.03 V	336	20.7	12.9

**REMARKS:**

- Emission Level(dBuV/m) = Raw Value(dBuV) + Correction Factor(dB/m)
- Correction Factor(dB/m) = Antenna Factor(dB/m) + Cable Factor(dB) – Pre-Amplifier Factor(dB)
- The other emission levels were very low against the limit.
- Margin value = Emission Level – Limit value
- " \* ": Fundamental frequency.
- " # ": The radiated frequency is out of the restricted band.

<b>CHANNEL</b>	TX Channel 48	<b>DETECTOR FUNCTION</b>	Peak (PK)
<b>FREQUENCY RANGE</b>	1GHz ~ 40GHz		Average (AV)

**ANTENNA POLARITY & TEST DISTANCE: HORIZONTAL AT 3 M**

NO.	FREQ. (MHz)	EMISSION LEVEL (dBuV/m)	LIMIT (dBuV/m)	MARGIN (dB)	ANTENNA HEIGHT (m)	TABLE ANGLE (Degree)	RAW VALUE (dBuV)	CORRECTION FACTOR (dB/m)
1	*5240.00	112.5 PK			1.39 H	243	110.3	2.2
2	*5240.00	103.2 AV			1.39 H	243	101.0	2.2
3	5350.00	52.2 PK	74.0	-21.8	1.39 H	243	49.9	2.3
4	5350.00	42.0 AV	54.0	-12.0	1.39 H	243	39.7	2.3
5	#10480.00	51.8 PK	68.2	-16.4	1.88 H	149	39.4	12.4
6	15720.00	45.7 PK	74.0	-28.3	1.47 H	252	33.7	12.0
7	15720.00	35.2 AV	54.0	-18.8	1.47 H	252	23.2	12.0

**ANTENNA POLARITY & TEST DISTANCE: VERTICAL AT 3 M**

NO.	FREQ. (MHz)	EMISSION LEVEL (dBuV/m)	LIMIT (dBuV/m)	MARGIN (dB)	ANTENNA HEIGHT (m)	TABLE ANGLE (Degree)	RAW VALUE (dBuV)	CORRECTION FACTOR (dB/m)
1	*5240.00	113.0 PK			2.66 V	188	110.8	2.2
2	*5240.00	104.8 AV			2.66 V	188	102.6	2.2
3	5350.00	53.1 PK	74.0	-20.9	2.66 V	188	50.8	2.3
4	5350.00	43.3 AV	54.0	-10.7	2.66 V	188	41.0	2.3
5	#10480.00	52.2 PK	68.2	-16.0	1.68 V	15	39.8	12.4
6	15720.00	45.9 PK	74.0	-28.1	1.05 V	341	33.9	12.0
7	15720.00	35.4 AV	54.0	-18.6	1.05 V	341	23.4	12.0

**REMARKS:**

1. Emission Level(dBuV/m) = Raw Value(dBuV) + Correction Factor(dB/m)
2. Correction Factor(dB/m) = Antenna Factor(dB/m) + Cable Factor(dB) – Pre-Amplifier Factor(dB)
3. The other emission levels were very low against the limit.
4. Margin value = Emission Level – Limit value
5. " \* ": Fundamental frequency.
6. " # ": The radiated frequency is out of the restricted band.



<b>CHANNEL</b>	TX Channel 149	<b>DETECTOR FUNCTION</b>	Peak (PK)
<b>FREQUENCY RANGE</b>	1GHz ~ 40GHz		Average (AV)

**ANTENNA POLARITY & TEST DISTANCE: HORIZONTAL AT 3 M**

NO.	FREQ. (MHz)	EMISSION LEVEL (dBuV/m)	LIMIT (dBuV/m)	MARGIN (dB)	ANTENNA HEIGHT (m)	TABLE ANGLE (Degree)	RAW VALUE (dBuV)	CORRECTION FACTOR (dB/m)
1	#5646.89	56.4 PK	68.2	-11.8	1.44 H	258	53.7	2.7
2	*5745.00	114.0 PK			1.44 H	258	111.1	2.9
3	*5745.00	104.6 AV			1.44 H	258	101.7	2.9
4	#5927.48	53.5 PK	68.2	-14.7	1.44 H	258	50.1	3.4
5	11490.00	51.6 PK	74.0	-22.4	1.32 H	268	39.3	12.3
6	11490.00	46.5 AV	54.0	-7.5	1.32 H	268	34.2	12.3
7	#17235.00	48.8 PK	68.2	-19.4	1.68 H	225	33.5	15.3

**ANTENNA POLARITY & TEST DISTANCE: VERTICAL AT 3 M**

NO.	FREQ. (MHz)	EMISSION LEVEL (dBuV/m)	LIMIT (dBuV/m)	MARGIN (dB)	ANTENNA HEIGHT (m)	TABLE ANGLE (Degree)	RAW VALUE (dBuV)	CORRECTION FACTOR (dB/m)
1	#5633.94	57.6 PK	68.2	-10.6	1.88 V	185	54.8	2.8
2	*5745.00	114.9 PK			1.88 V	185	112.0	2.9
3	*5745.00	106.2 AV			1.88 V	185	103.3	2.9
4	#5987.91	53.7 PK	68.2	-14.5	1.88 V	185	50.5	3.2
5	11490.00	51.1 PK	74.0	-22.9	1.33 V	178	38.8	12.3
6	11490.00	45.8 AV	54.0	-8.2	1.33 V	178	33.5	12.3
7	#17235.00	47.9 PK	68.2	-20.3	1.58 V	304	32.6	15.3

**REMARKS:**

1. Emission Level(dBuV/m) = Raw Value(dBuV) + Correction Factor(dB/m)
2. Correction Factor(dB/m) = Antenna Factor(dB/m) + Cable Factor(dB) – Pre-Amplifier Factor(dB)
3. The other emission levels were very low against the limit.
4. Margin value = Emission Level – Limit value
5. " \* ": Fundamental frequency.
6. " # ": The radiated frequency is out of the restricted band.

<b>CHANNEL</b>	TX Channel 157	<b>DETECTOR FUNCTION</b>	Peak (PK)
<b>FREQUENCY RANGE</b>	1GHz ~ 40GHz		Average (AV)

**ANTENNA POLARITY & TEST DISTANCE: HORIZONTAL AT 3 M**

NO.	FREQ. (MHz)	EMISSION LEVEL (dBuV/m)	LIMIT (dBuV/m)	MARGIN (dB)	ANTENNA HEIGHT (m)	TABLE ANGLE (Degree)	RAW VALUE (dBuV)	CORRECTION FACTOR (dB/m)
1	#5642.60	54.0 PK	68.2	-14.2	1.98 H	253	51.3	2.7
2	*5785.00	114.2 PK			1.98 H	253	111.1	3.1
3	*5785.00	104.6 AV			1.98 H	253	101.5	3.1
4	#5934.81	55.0 PK	68.2	-13.2	1.98 H	253	51.6	3.4
5	11570.00	51.6 PK	74.0	-22.4	1.37 H	279	39.2	12.4
6	11570.00	46.3 AV	54.0	-7.7	1.37 H	279	33.9	12.4
7	#17355.00	48.6 PK	68.2	-19.6	1.69 H	214	32.6	16.0

**ANTENNA POLARITY & TEST DISTANCE: VERTICAL AT 3 M**

NO.	FREQ. (MHz)	EMISSION LEVEL (dBuV/m)	LIMIT (dBuV/m)	MARGIN (dB)	ANTENNA HEIGHT (m)	TABLE ANGLE (Degree)	RAW VALUE (dBuV)	CORRECTION FACTOR (dB/m)
1	#5638.68	56.3 PK	68.2	-11.9	1.87 V	189	53.6	2.7
2	*5785.00	114.6 PK			1.87 V	189	111.5	3.1
3	*5785.00	106.0 AV			1.87 V	189	102.9	3.1
4	#5928.87	56.5 PK	68.2	-11.7	1.87 V	189	53.1	3.4
5	11570.00	51.2 PK	74.0	-22.8	1.33 V	189	38.8	12.4
6	11570.00	45.7 AV	54.0	-8.3	1.33 V	189	33.3	12.4
7	#17355.00	48.4 PK	68.2	-19.8	1.62 V	318	32.4	16.0

**REMARKS:**

1. Emission Level(dBuV/m) = Raw Value(dBuV) + Correction Factor(dB/m)
2. Correction Factor(dB/m) = Antenna Factor(dB/m) + Cable Factor(dB) – Pre-Amplifier Factor(dB)
3. The other emission levels were very low against the limit.
4. Margin value = Emission Level – Limit value
5. " \* ": Fundamental frequency.
6. " # ": The radiated frequency is out of the restricted band.

<b>CHANNEL</b>	TX Channel 165	<b>DETECTOR FUNCTION</b>	Peak (PK)
<b>FREQUENCY RANGE</b>	1GHz ~ 40GHz		Average (AV)

**ANTENNA POLARITY & TEST DISTANCE: HORIZONTAL AT 3 M**

NO.	FREQ. (MHz)	EMISSION LEVEL (dBuV/m)	LIMIT (dBuV/m)	MARGIN (dB)	ANTENNA HEIGHT (m)	TABLE ANGLE (Degree)	RAW VALUE (dBuV)	CORRECTION FACTOR (dB/m)
1	#5602.08	53.6 PK	68.2	-14.6	1.89 H	252	50.8	2.8
2	*5825.00	113.5 PK			1.89 H	252	110.3	3.2
3	*5825.00	104.2 AV			1.89 H	252	101.0	3.2
4	#5929.42	56.6 PK	68.2	-11.6	1.89 H	252	53.2	3.4
5	11650.00	52.3 PK	74.0	-21.7	1.38 H	284	39.9	12.4
6	11650.00	47.0 AV	54.0	-7.0	1.38 H	284	34.6	12.4
7	#17475.00	48.6 PK	68.2	-19.6	1.73 H	233	31.2	17.4

**ANTENNA POLARITY & TEST DISTANCE: VERTICAL AT 3 M**

NO.	FREQ. (MHz)	EMISSION LEVEL (dBuV/m)	LIMIT (dBuV/m)	MARGIN (dB)	ANTENNA HEIGHT (m)	TABLE ANGLE (Degree)	RAW VALUE (dBuV)	CORRECTION FACTOR (dB/m)
1	#5631.47	54.3 PK	68.2	-13.9	1.85 V	186	51.5	2.8
2	*5825.00	114.2 PK			1.85 V	186	111.0	3.2
3	*5825.00	105.8 AV			1.85 V	186	102.6	3.2
4	#5934.61	57.5 PK	68.2	-10.7	1.85 V	186	54.1	3.4
5	11650.00	50.5 PK	74.0	-23.5	1.31 V	164	38.1	12.4
6	11650.00	45.3 AV	54.0	-8.7	1.31 V	164	32.9	12.4
7	#17475.00	47.8 PK	68.2	-20.4	1.61 V	304	30.4	17.4

**REMARKS:**

1. Emission Level(dBuV/m) = Raw Value(dBuV) + Correction Factor(dB/m)
2. Correction Factor(dB/m) = Antenna Factor(dB/m) + Cable Factor(dB) – Pre-Amplifier Factor(dB)
3. The other emission levels were very low against the limit.
4. Margin value = Emission Level – Limit value
5. " \* ": Fundamental frequency.
6. " # ": The radiated frequency is out of the restricted band.

**802.11ac (VHT20)**

<b>CHANNEL</b>	TX Channel 36	<b>DETECTOR FUNCTION</b>	Peak (PK)
<b>FREQUENCY RANGE</b>	1GHz ~ 40GHz		Average (AV)

**ANTENNA POLARITY & TEST DISTANCE: HORIZONTAL AT 3 M**

NO.	FREQ. (MHz)	EMISSION LEVEL (dBuV/m)	LIMIT (dBuV/m)	MARGIN (dB)	ANTENNA HEIGHT (m)	TABLE ANGLE (Degree)	RAW VALUE (dBuV)	CORRECTION FACTOR (dB/m)
1	5150.00	67.7 PK	74.0	-6.3	1.49 H	255	65.1	2.6
2	5150.00	50.8 AV	54.0	-3.2	1.49 H	255	48.2	2.6
3	*5180.00	109.2 PK			1.49 H	255	106.7	2.5
4	*5180.00	99.1 AV			1.49 H	255	96.6	2.5
5	#10360.00	48.6 PK	68.2	-19.6	1.84 H	120	36.7	11.9
6	15540.00	43.7 PK	74.0	-30.3	1.39 H	252	31.3	12.4
7	15540.00	34.4 AV	54.0	-19.6	1.39 H	252	22.0	12.4

**ANTENNA POLARITY & TEST DISTANCE: VERTICAL AT 3 M**

NO.	FREQ. (MHz)	EMISSION LEVEL (dBuV/m)	LIMIT (dBuV/m)	MARGIN (dB)	ANTENNA HEIGHT (m)	TABLE ANGLE (Degree)	RAW VALUE (dBuV)	CORRECTION FACTOR (dB/m)
1	5150.00	73.3 PK	74.0	-0.7	2.76 V	189	70.7	2.6
2	5150.00	53.7 AV	54.0	-0.3	2.76 V	189	51.1	2.6
3	*5180.00	109.9 PK			2.76 V	189	107.4	2.5
4	*5180.00	101.0 AV			2.76 V	189	98.5	2.5
5	#10360.00	48.0 PK	68.2	-20.2	1.66 V	18	36.1	11.9
6	15540.00	43.6 PK	74.0	-30.4	1.04 V	354	31.2	12.4
7	15540.00	34.4 AV	54.0	-19.6	1.04 V	354	22.0	12.4

**REMARKS:**

1. Emission Level(dBuV/m) = Raw Value(dBuV) + Correction Factor(dB/m)
2. Correction Factor(dB/m) = Antenna Factor(dB/m) + Cable Factor(dB) – Pre-Amplifier Factor(dB)
3. The other emission levels were very low against the limit.
4. Margin value = Emission Level – Limit value
5. " \* ": Fundamental frequency.
6. " # ": The radiated frequency is out of the restricted band.

<b>CHANNEL</b>	TX Channel 40	<b>DETECTOR FUNCTION</b>	Peak (PK)
<b>FREQUENCY RANGE</b>	1GHz ~ 40GHz		Average (AV)

**ANTENNA POLARITY & TEST DISTANCE: HORIZONTAL AT 3 M**

NO.	FREQ. (MHz)	EMISSION LEVEL (dBuV/m)	LIMIT (dBuV/m)	MARGIN (dB)	ANTENNA HEIGHT (m)	TABLE ANGLE (Degree)	RAW VALUE (dBuV)	CORRECTION FACTOR (dB/m)
1	5150.00	68.1 PK	74.0	-5.9	1.50 H	242	65.5	2.6
2	5150.00	51.1 AV	54.0	-2.9	1.50 H	242	48.5	2.6
3	*5200.00	109.8 PK			1.50 H	242	107.4	2.4
4	*5200.00	100.8 AV			1.50 H	242	98.4	2.4
5	#10400.00	50.6 PK	68.2	-17.6	1.94 H	131	38.4	12.2
6	15600.00	44.8 PK	74.0	-29.2	1.52 H	252	31.9	12.9
7	15600.00	35.6 AV	54.0	-18.4	1.52 H	252	22.7	12.9

**ANTENNA POLARITY & TEST DISTANCE: VERTICAL AT 3 M**

NO.	FREQ. (MHz)	EMISSION LEVEL (dBuV/m)	LIMIT (dBuV/m)	MARGIN (dB)	ANTENNA HEIGHT (m)	TABLE ANGLE (Degree)	RAW VALUE (dBuV)	CORRECTION FACTOR (dB/m)
1	5150.00	67.7 PK	74.0	-6.3	2.64 V	187	65.1	2.6
2	5150.00	53.5 AV	54.0	-0.5	2.64 V	187	50.9	2.6
3	*5200.00	110.9 PK			2.64 V	187	108.5	2.4
4	*5200.00	101.7 AV			2.64 V	187	99.3	2.4
5	#10400.00	50.4 PK	68.2	-17.8	1.73 V	14	38.2	12.2
6	15600.00	44.6 PK	74.0	-29.4	1.03 V	336	31.7	12.9
7	15600.00	34.1 AV	54.0	-19.9	1.03 V	336	21.2	12.9

**REMARKS:**

1. Emission Level(dBuV/m) = Raw Value(dBuV) + Correction Factor(dB/m)
2. Correction Factor(dB/m) = Antenna Factor(dB/m) + Cable Factor(dB) – Pre-Amplifier Factor(dB)
3. The other emission levels were very low against the limit.
4. Margin value = Emission Level – Limit value
5. " \* ": Fundamental frequency.
6. " # ": The radiated frequency is out of the restricted band.

<b>CHANNEL</b>	TX Channel 48	<b>DETECTOR FUNCTION</b>	Peak (PK)
<b>FREQUENCY RANGE</b>	1GHz ~ 40GHz		Average (AV)

**ANTENNA POLARITY & TEST DISTANCE: HORIZONTAL AT 3 M**

NO.	FREQ. (MHz)	EMISSION LEVEL (dBuV/m)	LIMIT (dBuV/m)	MARGIN (dB)	ANTENNA HEIGHT (m)	TABLE ANGLE (Degree)	RAW VALUE (dBuV)	CORRECTION FACTOR (dB/m)
1	*5240.00	112.5 PK			1.47 H	241	110.3	2.2
2	*5240.00	103.1 AV			1.47 H	241	100.9	2.2
3	5350.00	53.0 PK	74.0	-21.0	1.47 H	241	50.7	2.3
4	5350.00	42.2 AV	54.0	-11.8	1.47 H	241	39.9	2.3
5	#10480.00	51.7 PK	68.2	-16.5	1.85 H	146	39.3	12.4
6	15720.00	46.2 PK	74.0	-27.8	1.43 H	247	34.2	12.0
7	15720.00	35.6 AV	54.0	-18.4	1.43 H	247	23.6	12.0

**ANTENNA POLARITY & TEST DISTANCE: VERTICAL AT 3 M**

NO.	FREQ. (MHz)	EMISSION LEVEL (dBuV/m)	LIMIT (dBuV/m)	MARGIN (dB)	ANTENNA HEIGHT (m)	TABLE ANGLE (Degree)	RAW VALUE (dBuV)	CORRECTION FACTOR (dB/m)
1	*5240.00	113.2 PK			2.72 V	186	111.0	2.2
2	*5240.00	104.9 AV			2.72 V	186	102.7	2.2
3	5350.00	53.0 PK	74.0	-21.0	2.72 V	186	50.7	2.3
4	5350.00	43.5 AV	54.0	-10.5	2.72 V	186	41.2	2.3
5	#10480.00	52.3 PK	68.2	-15.9	1.63 V	12	39.9	12.4
6	15720.00	46.1 PK	74.0	-27.9	1.05 V	332	34.1	12.0
7	15720.00	35.5 AV	54.0	-18.5	1.05 V	332	23.5	12.0

**REMARKS:**

1. Emission Level(dBuV/m) = Raw Value(dBuV) + Correction Factor(dB/m)
2. Correction Factor(dB/m) = Antenna Factor(dB/m) + Cable Factor(dB) – Pre-Amplifier Factor(dB)
3. The other emission levels were very low against the limit.
4. Margin value = Emission Level – Limit value
5. " \* ": Fundamental frequency.
6. " # ": The radiated frequency is out of the restricted band.

<b>CHANNEL</b>	TX Channel 149	<b>DETECTOR FUNCTION</b>	Peak (PK)
<b>FREQUENCY RANGE</b>	1GHz ~ 40GHz		Average (AV)

**ANTENNA POLARITY & TEST DISTANCE: HORIZONTAL AT 3 M**

NO.	FREQ. (MHz)	EMISSION LEVEL (dBuV/m)	LIMIT (dBuV/m)	MARGIN (dB)	ANTENNA HEIGHT (m)	TABLE ANGLE (Degree)	RAW VALUE (dBuV)	CORRECTION FACTOR (dB/m)
1	#5647.87	55.7 PK	68.2	-12.5	1.88 H	253	53.0	2.7
2	*5745.00	113.1 PK			1.88 H	253	110.2	2.9
3	*5745.00	104.8 AV			1.88 H	253	101.9	2.9
4	#5966.09	53.7 PK	68.2	-14.5	1.88 H	253	50.4	3.3
5	11490.00	51.7 PK	74.0	-22.3	1.29 H	269	39.4	12.3
6	11490.00	46.7 AV	54.0	-7.3	1.29 H	269	34.4	12.3
7	#17235.00	48.4 PK	68.2	-19.8	1.62 H	217	33.1	15.3

**ANTENNA POLARITY & TEST DISTANCE: VERTICAL AT 3 M**

NO.	FREQ. (MHz)	EMISSION LEVEL (dBuV/m)	LIMIT (dBuV/m)	MARGIN (dB)	ANTENNA HEIGHT (m)	TABLE ANGLE (Degree)	RAW VALUE (dBuV)	CORRECTION FACTOR (dB/m)
1	#5646.35	59.9 PK	68.2	-8.3	1.88 V	185	57.2	2.7
2	*5745.00	114.2 PK			1.88 V	185	111.3	2.9
3	*5745.00	105.9 AV			1.88 V	185	103.0	2.9
4	#5932.47	53.3 PK	68.2	-14.9	1.88 V	185	49.9	3.4
5	11490.00	50.8 PK	74.0	-23.2	1.29 V	168	38.5	12.3
6	11490.00	45.5 AV	54.0	-8.5	1.29 V	168	33.2	12.3
7	#17235.00	47.7 PK	68.2	-20.5	1.57 V	289	32.4	15.3

**REMARKS:**

1. Emission Level(dBuV/m) = Raw Value(dBuV) + Correction Factor(dB/m)
2. Correction Factor(dB/m) = Antenna Factor(dB/m) + Cable Factor(dB) – Pre-Amplifier Factor(dB)
3. The other emission levels were very low against the limit.
4. Margin value = Emission Level – Limit value
5. " \* ": Fundamental frequency.
6. " # ": The radiated frequency is out of the restricted band.

<b>CHANNEL</b>	TX Channel 157	<b>DETECTOR FUNCTION</b>	Peak (PK)
<b>FREQUENCY RANGE</b>	1GHz ~ 40GHz		Average (AV)

**ANTENNA POLARITY & TEST DISTANCE: HORIZONTAL AT 3 M**

NO.	FREQ. (MHz)	EMISSION LEVEL (dBuV/m)	LIMIT (dBuV/m)	MARGIN (dB)	ANTENNA HEIGHT (m)	TABLE ANGLE (Degree)	RAW VALUE (dBuV)	CORRECTION FACTOR (dB/m)
1	#5637.85	54.5 PK	68.2	-13.7	1.87 H	256	51.8	2.7
2	*5785.00	113.2 PK			1.87 H	256	110.1	3.1
3	*5785.00	104.8 AV			1.87 H	256	101.7	3.1
4	#5934.04	55.7 PK	68.2	-12.5	1.87 H	256	52.3	3.4
5	11570.00	51.2 PK	74.0	-22.8	1.27 H	276	38.8	12.4
6	11570.00	46.0 AV	54.0	-8.0	1.27 H	276	33.6	12.4
7	#17355.00	49.2 PK	68.2	-19.0	1.62 H	222	33.2	16.0

**ANTENNA POLARITY & TEST DISTANCE: VERTICAL AT 3 M**

NO.	FREQ. (MHz)	EMISSION LEVEL (dBuV/m)	LIMIT (dBuV/m)	MARGIN (dB)	ANTENNA HEIGHT (m)	TABLE ANGLE (Degree)	RAW VALUE (dBuV)	CORRECTION FACTOR (dB/m)
1	#5636.52	54.8 PK	68.2	-13.4	1.87 V	184	52.1	2.7
2	*5785.00	113.8 PK			1.87 V	184	110.7	3.1
3	*5785.00	105.6 AV			1.87 V	184	102.5	3.1
4	#5939.68	55.2 PK	68.2	-13.0	1.87 V	184	51.8	3.4
5	11570.00	51.6 PK	74.0	-22.4	1.33 V	166	39.2	12.4
6	11570.00	46.1 AV	54.0	-7.9	1.33 V	166	33.7	12.4
7	#17355.00	47.5 PK	68.2	-20.7	1.62 V	296	31.5	16.0

**REMARKS:**

1. Emission Level(dBuV/m) = Raw Value(dBuV) + Correction Factor(dB/m)
2. Correction Factor(dB/m) = Antenna Factor(dB/m) + Cable Factor(dB) – Pre-Amplifier Factor(dB)
3. The other emission levels were very low against the limit.
4. Margin value = Emission Level – Limit value
5. " \* ": Fundamental frequency.
6. " # ": The radiated frequency is out of the restricted band.



<b>CHANNEL</b>	TX Channel 165	<b>DETECTOR FUNCTION</b>	Peak (PK)
<b>FREQUENCY RANGE</b>	1GHz ~ 40GHz		Average (AV)

**ANTENNA POLARITY & TEST DISTANCE: HORIZONTAL AT 3 M**

NO.	FREQ. (MHz)	EMISSION LEVEL (dBuV/m)	LIMIT (dBuV/m)	MARGIN (dB)	ANTENNA HEIGHT (m)	TABLE ANGLE (Degree)	RAW VALUE (dBuV)	CORRECTION FACTOR (dB/m)
1	#5589.86	53.2 PK	68.2	-15.0	1.89 H	253	50.4	2.8
2	*5825.00	112.8 PK			1.89 H	253	109.6	3.2
3	*5825.00	104.6 AV			1.89 H	253	101.4	3.2
4	#5930.55	58.1 PK	68.2	-10.1	1.89 H	253	54.7	3.4
5	11650.00	51.6 PK	74.0	-22.4	1.34 H	270	39.2	12.4
6	11650.00	46.2 AV	54.0	-7.8	1.34 H	270	33.8	12.4
7	#17475.00	48.4 PK	68.2	-19.8	1.65 H	238	31.0	17.4

**ANTENNA POLARITY & TEST DISTANCE: VERTICAL AT 3 M**

NO.	FREQ. (MHz)	EMISSION LEVEL (dBuV/m)	LIMIT (dBuV/m)	MARGIN (dB)	ANTENNA HEIGHT (m)	TABLE ANGLE (Degree)	RAW VALUE (dBuV)	CORRECTION FACTOR (dB/m)
1	#5619.68	54.4 PK	68.2	-13.8	1.88 V	189	51.6	2.8
2	*5825.00	113.6 PK			1.88 V	189	110.4	3.2
3	*5825.00	105.2 AV			1.88 V	189	102.0	3.2
4	#5943.15	57.7 PK	68.2	-10.5	1.88 V	189	54.4	3.3
5	11650.00	51.0 PK	74.0	-23.0	1.30 V	175	38.6	12.4
6	11650.00	45.7 AV	54.0	-8.3	1.30 V	175	33.3	12.4
7	#17475.00	47.1 PK	68.2	-21.1	1.53 V	289	29.7	17.4

**REMARKS:**

1. Emission Level(dBuV/m) = Raw Value(dBuV) + Correction Factor(dB/m)
2. Correction Factor(dB/m) = Antenna Factor(dB/m) + Cable Factor(dB) – Pre-Amplifier Factor(dB)
3. The other emission levels were very low against the limit.
4. Margin value = Emission Level – Limit value
5. " \* ": Fundamental frequency.
6. " # ": The radiated frequency is out of the restricted band.

802.11ac (VHT40)

<b>CHANNEL</b>	TX Channel 38	<b>DETECTOR FUNCTION</b>	Peak (PK)
<b>FREQUENCY RANGE</b>	1GHz ~ 40GHz		Average (AV)

ANTENNA POLARITY & TEST DISTANCE: HORIZONTAL AT 3 M								
NO.	FREQ. (MHz)	EMISSION LEVEL (dBuV/m)	LIMIT (dBuV/m)	MARGIN (dB)	ANTENNA HEIGHT (m)	TABLE ANGLE (Degree)	RAW VALUE (dBuV)	CORRECTION FACTOR (dB/m)
1	5150.00	66.5 PK	74.0	-7.5	1.45 H	258	63.9	2.6
2	5150.00	51.5 AV	54.0	-2.5	1.45 H	258	48.9	2.6
3	*5190.00	101.2 PK			1.45 H	258	98.7	2.5
4	*5190.00	92.5 AV			1.45 H	258	90.0	2.5
5	5350.00	50.0 PK	74.0	-24.0	1.45 H	258	47.7	2.3
6	5350.00	37.7 AV	54.0	-16.3	1.45 H	258	35.4	2.3
7	#10380.00	50.2 PK	68.2	-18.0	1.89 H	138	38.2	12.0
8	15570.00	44.4 PK	74.0	-29.6	1.43 H	233	31.8	12.6
9	15570.00	35.2 AV	54.0	-18.8	1.43 H	233	22.6	12.6

ANTENNA POLARITY & TEST DISTANCE: VERTICAL AT 3 M								
NO.	FREQ. (MHz)	EMISSION LEVEL (dBuV/m)	LIMIT (dBuV/m)	MARGIN (dB)	ANTENNA HEIGHT (m)	TABLE ANGLE (Degree)	RAW VALUE (dBuV)	CORRECTION FACTOR (dB/m)
1	5150.00	69.6 PK	74.0	-4.4	2.61 V	192	67.0	2.6
2	<b>5150.00</b>	<b>53.8 AV</b>	<b>54.0</b>	<b>-0.2</b>	<b>2.61 V</b>	<b>192</b>	<b>51.2</b>	<b>2.6</b>
3	*5190.00	102.9 PK			2.61 V	192	100.4	2.5
4	*5190.00	94.4 AV			2.61 V	192	91.9	2.5
5	5350.00	50.2 PK	74.0	-23.8	2.61 V	192	47.9	2.3
6	5350.00	38.3 AV	54.0	-15.7	2.61 V	192	36.0	2.3
7	#10380.00	43.3 PK	68.2	-24.9	1.66 V	23	31.3	12.0
8	15570.00	44.2 PK	74.0	-29.8	1.09 V	342	31.6	12.6
9	15570.00	33.6 AV	54.0	-20.4	1.09 V	342	21.0	12.6

**REMARKS:**

- Emission Level(dBuV/m) = Raw Value(dBuV) + Correction Factor(dB/m)
- Correction Factor(dB/m) = Antenna Factor(dB/m) + Cable Factor(dB) – Pre-Amplifier Factor(dB)
- The other emission levels were very low against the limit.
- Margin value = Emission Level – Limit value
- " \* ": Fundamental frequency.
- " # ": The radiated frequency is out of the restricted band.

<b>CHANNEL</b>	TX Channel 46	<b>DETECTOR FUNCTION</b>	Peak (PK)
<b>FREQUENCY RANGE</b>	1GHz ~ 40GHz		Average (AV)

**ANTENNA POLARITY & TEST DISTANCE: HORIZONTAL AT 3 M**

NO.	FREQ. (MHz)	EMISSION LEVEL (dBuV/m)	LIMIT (dBuV/m)	MARGIN (dB)	ANTENNA HEIGHT (m)	TABLE ANGLE (Degree)	RAW VALUE (dBuV)	CORRECTION FACTOR (dB/m)
1	5150.00	66.4 PK	74.0	-7.6	1.48 H	267	63.8	2.6
2	5150.00	51.1 AV	54.0	-2.9	1.48 H	267	48.5	2.6
3	*5230.00	106.6 PK			1.48 H	267	104.4	2.2
4	*5230.00	98.2 AV			1.48 H	267	96.0	2.2
5	5350.00	60.2 PK	74.0	-13.8	1.48 H	267	57.9	2.3
6	5350.00	46.5 AV	54.0	-7.5	1.48 H	267	44.2	2.3
7	#10460.00	50.5 PK	68.2	-17.7	1.87 H	137	38.1	12.4
8	15690.00	45.0 PK	74.0	-29.0	1.44 H	237	32.8	12.2
9	15690.00	36.1 AV	54.0	-17.9	1.44 H	237	23.9	12.2

**ANTENNA POLARITY & TEST DISTANCE: VERTICAL AT 3 M**

NO.	FREQ. (MHz)	EMISSION LEVEL (dBuV/m)	LIMIT (dBuV/m)	MARGIN (dB)	ANTENNA HEIGHT (m)	TABLE ANGLE (Degree)	RAW VALUE (dBuV)	CORRECTION FACTOR (dB/m)
1	5150.00	65.4 PK	74.0	-8.6	2.62 V	190	62.8	2.6
2	5150.00	53.5 AV	54.0	-0.5	2.62 V	190	50.9	2.6
3	*5230.00	107.7 PK			2.62 V	190	105.5	2.2
4	*5230.00	99.8 AV			2.62 V	190	97.6	2.2
5	5350.00	62.5 PK	74.0	-11.5	2.62 V	190	60.2	2.3
6	5350.00	49.4 AV	54.0	-4.6	2.62 V	190	47.1	2.3
7	#10460.00	45.5 PK	68.2	-22.7	1.70 V	3	33.1	12.4
8	15690.00	45.3 PK	74.0	-28.7	1.01 V	344	33.1	12.2
9	15690.00	34.5 AV	54.0	-19.5	1.01 V	344	22.3	12.2

**REMARKS:**

1. Emission Level(dBuV/m) = Raw Value(dBuV) + Correction Factor(dB/m)
2. Correction Factor(dB/m) = Antenna Factor(dB/m) + Cable Factor(dB) – Pre-Amplifier Factor(dB)
3. The other emission levels were very low against the limit.
4. Margin value = Emission Level – Limit value
5. " \* ": Fundamental frequency.
6. " # ": The radiated frequency is out of the restricted band.

<b>CHANNEL</b>	TX Channel 151	<b>DETECTOR FUNCTION</b>	Peak (PK)
<b>FREQUENCY RANGE</b>	1GHz ~ 40GHz		Average (AV)

**ANTENNA POLARITY & TEST DISTANCE: HORIZONTAL AT 3 M**

NO.	FREQ. (MHz)	EMISSION LEVEL (dBuV/m)	LIMIT (dBuV/m)	MARGIN (dB)	ANTENNA HEIGHT (m)	TABLE ANGLE (Degree)	RAW VALUE (dBuV)	CORRECTION FACTOR (dB/m)
1	#5649.54	65.2 PK	68.2	-3.0	1.85 H	252	62.5	2.7
2	*5755.00	109.3 PK			1.85 H	252	106.3	3.0
3	*5755.00	100.6 AV			1.85 H	252	97.6	3.0
4	#5928.43	55.3 PK	68.2	-12.9	1.85 H	252	51.9	3.4
5	11510.00	51.3 PK	74.0	-22.7	1.43 H	288	39.0	12.3
6	11510.00	46.0 AV	54.0	-8.0	1.43 H	288	33.7	12.3
7	#17265.00	47.9 PK	68.2	-20.3	1.64 H	219	32.5	15.4

**ANTENNA POLARITY & TEST DISTANCE: VERTICAL AT 3 M**

NO.	FREQ. (MHz)	EMISSION LEVEL (dBuV/m)	LIMIT (dBuV/m)	MARGIN (dB)	ANTENNA HEIGHT (m)	TABLE ANGLE (Degree)	RAW VALUE (dBuV)	CORRECTION FACTOR (dB/m)
1	#5646.03	67.8 PK	68.2	-0.4	1.88 V	184	65.1	2.7
2	*5755.00	110.5 PK			1.88 V	184	107.5	3.0
3	*5755.00	101.8 AV			1.88 V	184	98.8	3.0
4	#5938.88	55.4 PK	68.2	-12.8	1.88 V	184	52.0	3.4
5	11510.00	48.8 PK	74.0	-25.2	1.25 V	169	36.5	12.3
6	11510.00	43.7 AV	54.0	-10.3	1.25 V	169	31.4	12.3
7	#17265.00	46.2 PK	68.2	-22.0	1.54 V	310	30.8	15.4

**REMARKS:**

1. Emission Level(dBuV/m) = Raw Value(dBuV) + Correction Factor(dB/m)
2. Correction Factor(dB/m) = Antenna Factor(dB/m) + Cable Factor(dB) – Pre-Amplifier Factor(dB)
3. The other emission levels were very low against the limit.
4. Margin value = Emission Level – Limit value
5. " \* ": Fundamental frequency.
6. " # ": The radiated frequency is out of the restricted band.

<b>CHANNEL</b>	TX Channel 159	<b>DETECTOR FUNCTION</b>	Peak (PK)
<b>FREQUENCY RANGE</b>	1GHz ~ 40GHz		Average (AV)

**ANTENNA POLARITY & TEST DISTANCE: HORIZONTAL AT 3 M**

NO.	FREQ. (MHz)	EMISSION LEVEL (dBuV/m)	LIMIT (dBuV/m)	MARGIN (dB)	ANTENNA HEIGHT (m)	TABLE ANGLE (Degree)	RAW VALUE (dBuV)	CORRECTION FACTOR (dB/m)
1	#5648.69	58.3 PK	68.2	-9.9	1.88 H	251	55.6	2.7
2	*5795.00	110.2 PK			1.88 H	251	107.2	3.0
3	*5795.00	101.4 AV			1.88 H	251	98.4	3.0
4	#5925.70	61.2 PK	68.2	-7.0	1.88 H	251	57.8	3.4
5	11590.00	52.7 PK	74.0	-21.3	1.38 H	278	40.3	12.4
6	11590.00	47.2 AV	54.0	-6.8	1.38 H	278	34.8	12.4
7	#17385.00	49.3 PK	68.2	-18.9	1.70 H	233	33.1	16.2

**ANTENNA POLARITY & TEST DISTANCE: VERTICAL AT 3 M**

NO.	FREQ. (MHz)	EMISSION LEVEL (dBuV/m)	LIMIT (dBuV/m)	MARGIN (dB)	ANTENNA HEIGHT (m)	TABLE ANGLE (Degree)	RAW VALUE (dBuV)	CORRECTION FACTOR (dB/m)
1	#5633.47	57.9 PK	68.2	-10.3	1.86 V	187	55.1	2.8
2	*5795.00	110.8 PK			1.86 V	187	107.8	3.0
3	*5795.00	102.0 AV			1.86 V	187	99.0	3.0
4	#5934.39	60.2 PK	68.2	-8.0	1.86 V	187	56.8	3.4
5	11590.00	50.7 PK	74.0	-23.3	1.27 V	172	38.3	12.4
6	11590.00	45.3 AV	54.0	-8.7	1.27 V	172	32.9	12.4
7	#17385.00	47.3 PK	68.2	-20.9	1.58 V	295	31.1	16.2

**REMARKS:**

1. Emission Level(dBuV/m) = Raw Value(dBuV) + Correction Factor(dB/m)
2. Correction Factor(dB/m) = Antenna Factor(dB/m) + Cable Factor(dB) – Pre-Amplifier Factor(dB)
3. The other emission levels were very low against the limit.
4. Margin value = Emission Level – Limit value
5. " \* ": Fundamental frequency.
6. " # ": The radiated frequency is out of the restricted band.

**802.11ac (VHT80)**

<b>CHANNEL</b>	TX Channel 42	<b>DETECTOR FUNCTION</b>	Peak (PK)
<b>FREQUENCY RANGE</b>	1GHz ~ 40GHz		Average (AV)

**ANTENNA POLARITY & TEST DISTANCE: HORIZONTAL AT 3 M**

NO.	FREQ. (MHz)	EMISSION LEVEL (dBuV/m)	LIMIT (dBuV/m)	MARGIN (dB)	ANTENNA HEIGHT (m)	TABLE ANGLE (Degree)	RAW VALUE (dBuV)	CORRECTION FACTOR (dB/m)
1	5150.00	63.0 PK	74.0	-11.0	1.89 H	252	60.4	2.6
2	5150.00	52.2 AV	54.0	-1.8	1.89 H	252	49.6	2.6
3	*5210.00	98.1 PK			1.89 H	252	95.7	2.4
4	*5210.00	89.2 AV			1.89 H	252	86.8	2.4
5	5350.00	51.0 PK	74.0	-23.0	1.89 H	252	48.7	2.3
6	5350.00	41.5 AV	54.0	-12.5	1.89 H	252	39.2	2.3
7	#10420.00	43.2 PK	68.2	-25.0	1.70 H	175	31.0	12.2
8	15630.00	44.5 PK	74.0	-29.5	1.30 H	167	31.8	12.7
9	15630.00	35.5 AV	54.0	-18.5	1.30 H	167	22.8	12.7

**ANTENNA POLARITY & TEST DISTANCE: VERTICAL AT 3 M**

NO.	FREQ. (MHz)	EMISSION LEVEL (dBuV/m)	LIMIT (dBuV/m)	MARGIN (dB)	ANTENNA HEIGHT (m)	TABLE ANGLE (Degree)	RAW VALUE (dBuV)	CORRECTION FACTOR (dB/m)
1	5150.00	64.4 PK	74.0	-9.6	2.59 V	192	61.8	2.6
2	5150.00	53.5 AV	54.0	-0.5	2.59 V	192	50.9	2.6
3	*5210.00	98.8 PK			2.59 V	192	96.4	2.4
4	*5210.00	90.5 AV			2.59 V	192	88.1	2.4
5	5350.00	51.5 PK	74.0	-22.5	2.59 V	192	49.2	2.3
6	5350.00	41.9 AV	54.0	-12.1	2.59 V	192	39.6	2.3
7	#10420.00	43.2 PK	68.2	-25.0	1.65 V	169	31.0	12.2
8	15630.00	44.2 PK	74.0	-29.8	1.29 V	172	31.5	12.7
9	15630.00	35.3 AV	54.0	-18.7	1.29 V	172	22.6	12.7

**REMARKS:**

1. Emission Level(dBuV/m) = Raw Value(dBuV) + Correction Factor(dB/m)
2. Correction Factor(dB/m) = Antenna Factor(dB/m) + Cable Factor(dB) – Pre-Amplifier Factor(dB)
3. The other emission levels were very low against the limit.
4. Margin value = Emission Level – Limit value
5. " \* ": Fundamental frequency.
6. " # ": The radiated frequency is out of the restricted band.

<b>CHANNEL</b>	TX Channel 155	<b>DETECTOR FUNCTION</b>	Peak (PK)
<b>FREQUENCY RANGE</b>	1GHz ~ 40GHz		Average (AV)

**ANTENNA POLARITY & TEST DISTANCE: HORIZONTAL AT 3 M**

NO.	FREQ. (MHz)	EMISSION LEVEL (dBuV/m)	LIMIT (dBuV/m)	MARGIN (dB)	ANTENNA HEIGHT (m)	TABLE ANGLE (Degree)	RAW VALUE (dBuV)	CORRECTION FACTOR (dB/m)
1	#5648.24	64.3 PK	68.2	-3.9	1.88 H	248	61.6	2.7
2	*5775.00	105.5 PK			1.88 H	248	102.5	3.0
3	*5775.00	97.9 AV			1.88 H	248	94.9	3.0
4	#5933.05	60.2 PK	68.2	-8.0	1.88 H	248	56.8	3.4
5	11550.00	48.4 PK	74.0	-25.6	1.37 H	273	36.0	12.4
6	11550.00	42.6 AV	54.0	-11.4	1.37 H	273	30.2	12.4
7	#17325.00	45.1 PK	68.2	-23.1	1.75 H	236	29.4	15.7

**ANTENNA POLARITY & TEST DISTANCE: VERTICAL AT 3 M**

NO.	FREQ. (MHz)	EMISSION LEVEL (dBuV/m)	LIMIT (dBuV/m)	MARGIN (dB)	ANTENNA HEIGHT (m)	TABLE ANGLE (Degree)	RAW VALUE (dBuV)	CORRECTION FACTOR (dB/m)
1	#5643.84	67.7 PK	68.2	-0.5	1.65 V	180	65.0	2.7
2	*5775.00	106.2 PK			1.65 V	180	103.2	3.0
3	*5775.00	97.6 AV			1.65 V	180	94.6	3.0
4	#5928.09	62.3 PK	68.2	-5.9	1.65 V	180	58.9	3.4
5	11550.00	45.4 PK	74.0	-28.6	1.31 V	179	33.0	12.4
6	11550.00	40.0 AV	54.0	-14.0	1.31 V	179	27.6	12.4
7	#17325.00	42.4 PK	68.2	-25.8	1.62 V	294	26.7	15.7

**REMARKS:**

1. Emission Level(dBuV/m) = Raw Value(dBuV) + Correction Factor(dB/m)
2. Correction Factor(dB/m) = Antenna Factor(dB/m) + Cable Factor(dB) – Pre-Amplifier Factor(dB)
3. The other emission levels were very low against the limit.
4. Margin value = Emission Level – Limit value
5. " \* ": Fundamental frequency.
6. " # ": The radiated frequency is out of the restricted band.

Below 1GHz Data:

<b>CHANNEL</b>	TX Channel 149	<b>DETECTOR FUNCTION</b>	Quasi-Peak (QP)
<b>FREQUENCY RANGE</b>	9kHz ~ 1GHz		

**ANTENNA POLARITY & TEST DISTANCE: HORIZONTAL AT 3 M**

NO.	FREQ. (MHz)	EMISSION LEVEL (dBuV/m)	LIMIT (dBuV/m)	MARGIN (dB)	ANTENNA HEIGHT (m)	TABLE ANGLE (Degree)	RAW VALUE (dBuV)	CORRECTION FACTOR (dB/m)
1	114.34	25.6 QP	43.5	-17.9	1.00 H	337	35.7	-10.1
2	247.50	45.0 QP	46.0	-1.0	1.50 H	128	54.1	-9.1
3	270.66	41.7 QP	46.0	-4.3	1.50 H	244	49.7	-8.0
4	332.08	32.4 QP	46.0	-13.6	1.50 H	194	38.2	-5.8
5	401.61	42.1 QP	46.0	-3.9	1.50 H	223	46.6	-4.5
6	983.97	35.3 QP	54.0	-18.7	1.00 H	48	29.4	5.9

**REMARKS:**

1. Emission Level(dBuV/m) = Raw Value(dBuV) + Correction Factor(dB/m)
2. Correction Factor(dB/m) = Antenna Factor(dB/m) + Cable Factor(dB) – Pre-Amplifier Factor(dB)
3. Margin value = Emission Level – Limit value
4. The emission levels were very low against the limit of frequency range 9kHz~30MHz: the amplitude of spurious emissions attenuated more than 20 dB below the permissible value to be report.
5. Radiated emissions which fall in the restricted bands, as defined in FCC 15.205(a), must also comply with the radiated emission limits specified in FCC 15.209(a), the other emission shall be below -27dBm/MHz.

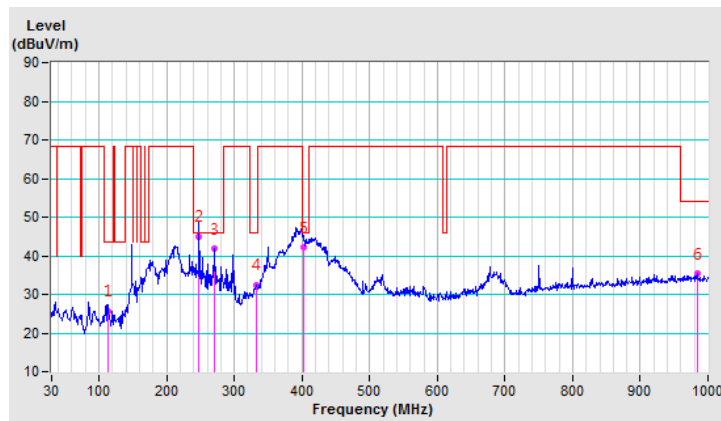



<b>CHANNEL</b>	TX Channel 149	<b>DETECTOR FUNCTION</b>	Quasi-Peak (QP)
<b>FREQUENCY RANGE</b>	9kHz ~ 1GHz		

**ANTENNA POLARITY & TEST DISTANCE: VERTICAL AT 3 M**

NO.	FREQ. (MHz)	EMISSION LEVEL (dBuV/m)	LIMIT (dBuV/m)	MARGIN (dB)	ANTENNA HEIGHT (m)	TABLE ANGLE (Degree)	RAW VALUE (dBuV)	CORRECTION FACTOR (dB/m)
1	37.50	31.3 QP	40.0	-8.7	1.50 V	0	40.0	-8.7
2	74.11	32.8 QP	40.0	-7.2	2.00 V	285	43.8	-11.0
3	247.52	45.5 QP	46.0	-0.5	1.00 V	71	54.6	-9.1
4	270.66	40.7 QP	46.0	-5.3	2.00 V	2	48.7	-8.0
5	334.99	32.4 QP	46.0	-13.6	1.50 V	307	38.2	-5.8
6	400.08	44.7 QP	46.0	-1.3	1.50 V	295	49.2	-4.5

**REMARKS:**

1. Emission Level(dBuV/m) = Raw Value(dBuV) + Correction Factor(dB/m)
2. Correction Factor(dB/m) = Antenna Factor(dB/m) + Cable Factor(dB) – Pre-Amplifier Factor(dB)
3. Margin value = Emission Level – Limit value
4. The emission levels were very low against the limit of frequency range 9kHz~30MHz: the amplitude of spurious emissions attenuated more than 20 dB below the permissible value to be report.
5. Radiated emissions which fall in the restricted bands, as defined in FCC 15.205(a), must also comply with the radiated emission limits specified in FCC 15.209(a), the other emission shall be below -27dBm/MHz.

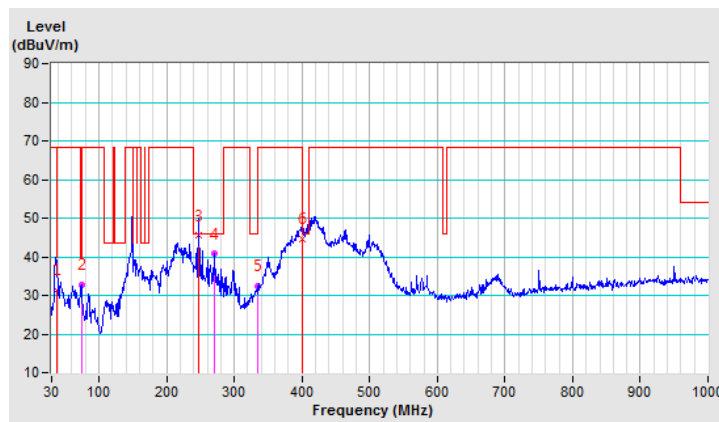

## 4.2 Conducted Emission Measurement

### 4.2.1 Limits of Conducted Emission Measurement

Frequency (MHz)	Conducted Limit (dBuV)	
	Quasi-peak	Average
0.15 - 0.5	66 - 56	56 - 46
0.50 - 5.0	56	46
5.0 - 30.0	60	50

Note: 1. The lower limit shall apply at the transition frequencies.

2. The limit decreases in line with the logarithm of the frequency in the range of 0.15 to 0.50MHz.

### 4.2.2 Test Instruments

DESCRIPTION & MANUFACTURER	MODEL NO.	SERIAL NO.	CALIBRATED DATE	CALIBRATED UNTIL
Test Receiver R&S	ESCS 30	847124/029	Nov. 01, 2017	Oct. 31, 2018
Line-Impedance Stabilization Network (for EUT) R&S	ESH3-Z5	848773/004	Nov. 15, 2017	Nov. 14, 2018
Line-Impedance Stabilization Network (for Peripheral) R&S	ENV216	100072	June 04, 2018	June 03, 2019
50 ohms Terminator	N/A	EMC-04	Nov. 01, 2017	Oct. 31, 2018
RF Cable	5D-FB	COCCAB-001	Sep. 28, 2018	Sep. 27, 2019
Fixed attenuator EMCI	STI02-2200-10	003	Mar. 16, 2018	Mar. 15, 2019
Software BVADT	BVADT_Cond_ V7.3.7.4	NA	NA	NA

**Note:**

1. The calibration interval of the above test instruments are 12 months and the calibrations are traceable to NML/ROC and NIST/USA.
2. The test was performed in Conduction 1.
3. Tested Date: Oct. 26, 2018

#### 4.2.3 Test Procedures

- The EUT was placed 0.4 meters from the conducting wall of the shielded room with EUT being connected to the power mains through a line impedance stabilization network (LISN). Other support units were connected to the power mains through another LISN. The two LISNs provide 50 ohm/ 50uH of coupling impedance for the measuring instrument.
- Both lines of the power mains connected to the EUT were checked for maximum conducted interference.
- The frequency range from 150kHz to 30MHz was searched. Emission levels under (Limit - 20dB) was not recorded.

**NOTE:** The resolution bandwidth and video bandwidth of test receiver is 9kHz for quasi-peak detection (QP) and average detection (AV) at frequency 0.15MHz-30MHz.

#### 4.2.4 Deviation from Test Standard

No deviation.

#### 4.2.5 Test Setup

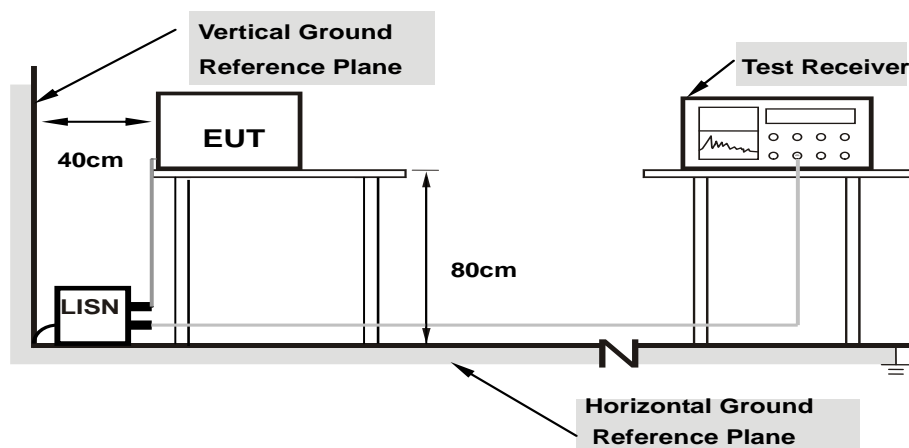

**Note: 1.Support units were connected to second LISN.**

For the actual test configuration, please refer to the attached file (Test Setup Photo).

#### 4.2.6 EUT Operating Conditions

Same as 4.1.6.

#### 4.2.7 Test Results

Phase	Line (L)	Detector Function	Quasi-Peak (QP) / Average (AV)							
No	Freq. [MHz]	Corr.	Reading Value		Emission Level		Limit		Margin	
		Factor	[dB (uV)]		[dB (uV)]		[dB (uV)]		(dB)	
		(dB)	Q.P.	AV.	Q.P.	AV.	Q.P.	AV.	Q.P.	AV.
1	0.49155	10.08	32.45	30.42	42.53	40.50	56.14	46.14	-13.61	-5.64
2	1.23828	10.12	31.46	25.19	41.58	35.31	56.00	46.00	-14.42	-10.69
3	1.47656	10.13	32.89	26.12	43.02	36.25	56.00	46.00	-12.98	-9.75
4	2.19922	10.17	32.04	20.82	42.21	30.99	56.00	46.00	-13.79	-15.01
5	2.46875	10.18	32.24	24.91	42.42	35.09	56.00	46.00	-13.58	-10.91
6	3.17188	10.21	33.19	19.20	43.40	29.41	56.00	46.00	-12.60	-16.59
7	3.46484	10.23	36.48	28.35	46.71	38.58	56.00	46.00	-9.29	-7.42
8	4.21094	10.26	37.79	29.62	48.05	39.88	56.00	46.00	-7.95	-6.12
9	4.41406	10.27	35.38	24.11	45.65	34.38	56.00	46.00	-10.35	-11.62
10	4.73047	10.28	37.07	25.67	47.35	35.95	56.00	46.00	-8.65	-10.05
11	5.23047	10.31	40.07	27.83	50.38	38.14	60.00	50.00	-9.62	-11.86
12	5.41797	10.32	40.16	30.60	50.48	40.92	60.00	50.00	-9.52	-9.08
13	6.42578	10.36	39.65	30.18	50.01	40.54	60.00	50.00	-9.99	-9.46
14	7.43750	10.41	38.48	30.46	48.89	40.87	60.00	50.00	-11.11	-9.13
15	8.33984	10.45	38.92	27.41	49.37	37.86	60.00	50.00	-10.63	-12.14
16	9.71875	10.52	41.45	28.70	51.97	39.22	60.00	50.00	-8.03	-10.78
17	10.45313	10.55	43.47	32.11	54.02	42.66	60.00	50.00	-5.98	-7.34
18	11.22266	10.60	37.57	26.74	48.17	37.34	60.00	50.00	-11.83	-12.66

#### REMARKS:

1. Q.P. and AV. are abbreviations of quasi-peak and average individually.
2. The emission levels of other frequencies were very low against the limit.
3. Margin value = Emission level - Limit value
4. Correction factor = Insertion loss + Cable loss
5. Emission Level = Correction Factor + Reading Value.

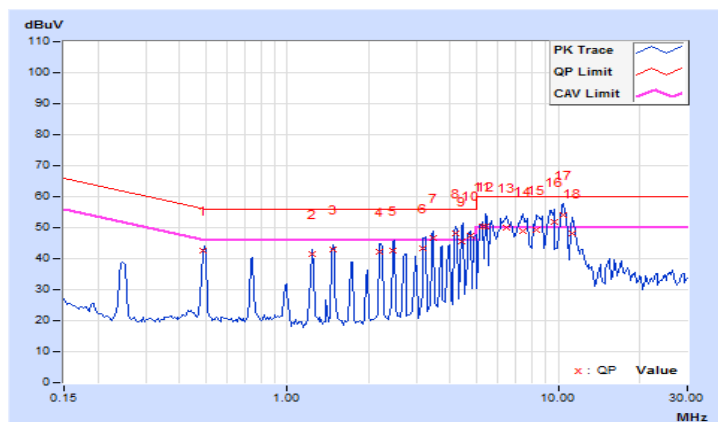

Phase	Neutral (N)	Detector Function	Quasi-Peak (QP) / Average (AV)
-------	-------------	-------------------	--------------------------------

No	Freq. [MHz]	Corr.	Reading Value		Emission Level		Limit		Margin	
		Factor	[dB (uV)]		[dB (uV)]		[dB (uV)]		(dB)	
		(dB)	Q.P.	AV.	Q.P.	AV.	Q.P.	AV.	Q.P.	AV.
1	0.50000	9.97	33.23	26.12	43.20	36.09	56.00	46.00	-12.80	-9.91
2	1.23047	10.00	33.60	27.94	43.60	37.94	56.00	46.00	-12.40	-8.06
3	1.49219	10.01	35.11	26.21	45.12	36.22	56.00	46.00	-10.88	-9.78
4	2.21094	10.05	34.26	26.22	44.31	36.27	56.00	46.00	-11.69	-9.73
5	2.46094	10.06	35.79	27.60	45.85	37.66	56.00	46.00	-10.15	-8.34
6	3.19141	10.09	35.14	24.97	45.23	35.06	56.00	46.00	-10.77	-10.94
7	3.44141	10.10	37.03	28.18	47.13	38.28	56.00	46.00	-8.87	-7.72
8	4.18359	10.13	38.46	29.26	48.59	39.39	56.00	46.00	-7.41	-6.61
9	4.42969	10.14	39.76	30.33	49.90	40.47	56.00	46.00	-6.10	-5.53
10	4.66797	10.15	36.61	26.77	46.76	36.92	56.00	46.00	-9.24	-9.08
11	5.48047	10.18	41.58	29.16	51.76	39.34	60.00	50.00	-8.24	-10.66
12	6.39453	10.22	41.99	31.66	52.21	41.88	60.00	50.00	-7.79	-8.12
13	7.42578	10.27	41.49	32.62	51.76	42.89	60.00	50.00	-8.24	-7.11
14	8.47266	10.31	40.27	27.28	50.58	37.59	60.00	50.00	-9.42	-12.41
15	9.46094	10.36	43.64	31.21	54.00	41.57	60.00	50.00	-6.00	-8.43
<b>16</b>	<b>10.33594</b>	<b>10.40</b>	<b>44.64</b>	<b>33.28</b>	<b>55.04</b>	<b>43.68</b>	<b>60.00</b>	<b>50.00</b>	<b>-4.96</b>	<b>-6.32</b>
17	11.38281	10.45	40.50	31.18	50.95	41.63	60.00	50.00	-9.05	-8.37
18	12.22266	10.49	31.99	22.13	42.48	32.62	60.00	50.00	-17.52	-17.38

#### REMARKS:

1. Q.P. and AV. are abbreviations of quasi-peak and average individually.
2. The emission levels of other frequencies were very low against the limit.
3. Margin value = Emission level - Limit value
4. Correction factor = Insertion loss + Cable loss
5. Emission Level = Correction Factor + Reading Value.

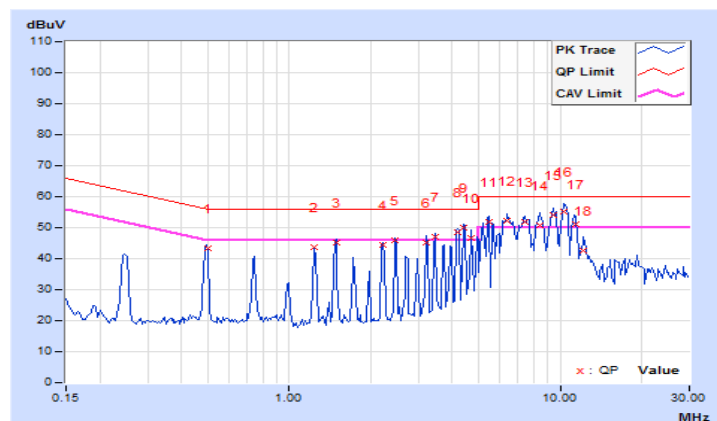

### 4.3 Transmit Power Measurement

#### 4.3.1 Limits of Transmit Power Measurement

Operation Band	EUT Category		Limit
U-NII-1	√	Outdoor Access Point	1 Watt (30 dBm) (Max. e.i.r.p ≤ 125mW(21 dBm) at any elevation angle above 30 degrees as measured from the horizon)
		Fixed point-to-point Access Point	1 Watt (30 dBm)
		Indoor Access Point	1 Watt (30 dBm)
	√	Client device	250mW (24 dBm)
U-NII-2A			250mW (24 dBm) or 11 dBm+10 log B*
U-NII-2C			250mW (24 dBm) or 11 dBm+10 log B*
U-NII-3		√	1 Watt (30 dBm)

\*B is the 26 dB emission bandwidth in megahertz

Per KDB 662911 Method of conducted output power measurement on IEEE 802.11 devices,

Array Gain = 0 dB (i.e., no array gain) for  $N_{ANT} \leq 4$ ;

Array Gain = 0 dB (i.e., no array gain) for channel widths  $\geq 40$  MHz for any  $N_{ANT}$ ;

Array Gain =  $5 \log(N_{ANT}/N_{SS})$  dB or 3 dB, whichever is less for 20-MHz channel widths with  $N_{ANT} \geq 5$ .

For power measurements on all other devices: Array Gain =  $10 \log(N_{ANT}/N_{SS})$  dB.

#### 4.3.2 Test Setup

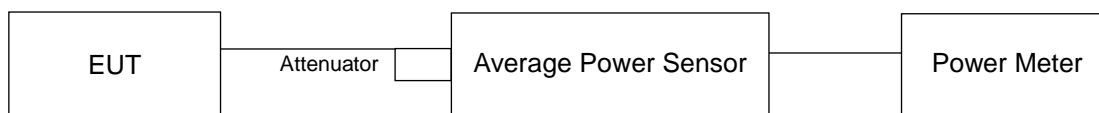

#### 4.3.3 Test Instruments

Refer to section 4.1.2 to get information of above instrument.

#### 4.3.4 Test Procedure

Method PM is used to perform output power measurement, trigger and gating function of wide band power meter is enabled to measure max output power of TX on burst. Duty factor is not added to measured value.

#### 4.3.5 Deviation from Test Standard

No deviation.

#### 4.3.6 EUT Operating Condition

The software provided by client to enable the EUT under transmission condition continuously at lowest, middle and highest channel frequencies individually.

#### 4.3.7 Test Result (Mode 1)

##### 802.11a

Chan.	Chan. Freq. (MHz)	Maximum Conducted Power (dBm)		Total Power (mW)	Total Power (dBm)	Limit (dBm)	Pass / Fail
		Chain 0	Chain 1				
36	5180	16.35	16.31	85.908	19.34	30.00	Pass
40	5200	16.33	16.20	84.641	19.28	30.00	Pass
48	5240	16.34	16.22	84.932	19.29	30.00	Pass

##### EIRP POWER OUTPUT

Chan.	Chan. Freq. (MHz)	EIRP Power (mW)	EIRP Power (dBm)	Power Limit (dBm)	Pass / Fail
36	5180	121.060	20.83	21.00	Pass
40	5200	119.399	20.77	21.00	Pass
48	5240	119.674	20.78	21.00	Pass

\*This device is outdoor access point and antenna at any elevation angle above 30 degrees as measured from the horizon, therefore Max. e.i.r.p  $\leq$  125mW(21 dBm) to compliance.

##### 802.11ac (VHT20)

Chan.	Chan. Freq. (MHz)	Maximum Conducted Power (dBm)		Total Power (mW)	Total Power (dBm)	Limit (dBm)	Pass / Fail
		Chain 0	Chain 1				
36	5180	16.28	16.36	85.713	19.33	30.00	Pass
40	5200	16.32	16.41	86.607	19.38	30.00	Pass
48	5240	16.35	16.37	86.503	19.37	30.00	Pass

##### EIRP POWER OUTPUT

Chan.	Chan. Freq. (MHz)	EIRP Power (mW)	EIRP Power (dBm)	Power Limit (dBm)	Pass / Fail
36	5180	120.781	20.82	21.00	Pass
40	5200	122.180	20.87	21.00	Pass
48	5240	121.899	20.86	21.00	Pass

\*This device is outdoor access point and antenna at any elevation angle above 30 degrees as measured from the horizon, therefore Max. e.i.r.p  $\leq$  125mW(21 dBm) to compliance.

### 802.11ac (VHT40)

Chan.	Chan. Freq. (MHz)	Maximum Conducted Power (dBm)		Total Power (mW)	Total Power (dBm)	Limit (dBm)	Pass / Fail
		Chain 0	Chain 1				
38	5190	13.45	13.35	43.758	16.41	30.00	Pass
46	5230	16.36	16.54	88.333	19.46	30.00	Pass

### EIRP POWER OUTPUT

Chan.	Chan. Freq. (MHz)	EIRP Power (mW)	EIRP Power (dBm)	Power Limit (dBm)	Pass / Fail
38	5190	61.660	17.90	21.00	Pass
46	5230	124.451	20.95	21.00	Pass

\*This device is outdoor access point and antenna at any elevation angle above 30 degrees as measured from the horizon, therefore Max. e.i.r.p  $\leq$  125mW(21 dBm) to compliance.

### 802.11ac (VHT80)

Chan.	Chan. Freq. (MHz)	Maximum Conducted Power (dBm)		Total Power (mW)	Total Power (dBm)	Limit (dBm)	Pass / Fail
		Chain 0	Chain 1				
42	5210	12.15	12.52	34.271	15.35	30.00	Pass

### EIRP POWER OUTPUT

Chan.	Chan. Freq. (MHz)	EIRP Power (mW)	EIRP Power (dBm)	Power Limit (dBm)	Pass / Fail
42	5210	48.306	16.84	21.00	Pass

\*This device is outdoor access point and antenna at any elevation angle above 30 degrees as measured from the horizon, therefore Max. e.i.r.p  $\leq$  125mW(21 dBm) to compliance.



#### 4.3.8 Test Result (Mode 2)

##### 802.11a

Chan.	Chan. Freq. (MHz)	Maximum Conducted Power (dBm)		Total Power (mW)	Total Power (dBm)	Limit (dBm)	Pass / Fail
		Chain 0	Chain 1				
36	5180	17.33	17.24	107.041	20.30	24.00	Pass
40	5200	18.65	18.74	148.099	21.71	24.00	Pass
48	5240	19.87	20.10	199.38	23.00	24.00	Pass

##### 802.11ac (VHT20)

Chan.	Chan. Freq. (MHz)	Maximum Conducted Power (dBm)		Total Power (mW)	Total Power (dBm)	Limit (dBm)	Pass / Fail
		Chain 0	Chain 1				
36	5180	16.78	16.84	95.949	19.82	24.00	Pass
40	5200	18.35	18.74	143.208	21.56	24.00	Pass
48	5240	19.74	19.84	190.572	22.80	24.00	Pass

##### 802.11ac (VHT40)

Chan.	Chan. Freq. (MHz)	Maximum Conducted Power (dBm)		Total Power (mW)	Total Power (dBm)	Limit (dBm)	Pass / Fail
		Chain 0	Chain 1				
38	5190	13.45	13.35	43.758	16.41	24.00	Pass
46	5230	17.36	17.65	112.66	20.52	24.00	Pass

##### 802.11ac (VHT80)

Chan.	Chan. Freq. (MHz)	Maximum Conducted Power (dBm)		Total Power (mW)	Total Power (dBm)	Limit (dBm)	Pass / Fail
		Chain 0	Chain 1				
42	5210	12.15	12.52	34.271	15.35	24.00	Pass

#### 4.3.9 Test Result

##### 802.11a

Chan.	Chan. Freq. (MHz)	Maximum Conducted Power (dBm)		Total Power (mW)	Total Power (dBm)	Limit (dBm)	Pass / Fail
		Chain 0	Chain 1				
149	5745	21.12	21.32	264.939	24.23	30.00	Pass
157	5785	21.05	21.25	260.702	24.16	30.00	Pass
165	5825	20.84	21.29	255.925	24.08	30.00	Pass

##### 802.11ac (VHT20)

Chan.	Chan. Freq. (MHz)	Maximum Conducted Power (dBm)		Total Power (mW)	Total Power (dBm)	Limit (dBm)	Pass / Fail
		Chain 0	Chain 1				
149	5745	21.15	21.40	268.355	24.29	30.00	Pass
157	5785	21.03	21.22	259.199	24.14	30.00	Pass
165	5825	20.78	21.18	250.894	23.99	30.00	Pass

##### 802.11ac (VHT40)

Chan.	Chan. Freq. (MHz)	Maximum Conducted Power (dBm)		Total Power (mW)	Total Power (dBm)	Limit (dBm)	Pass / Fail
		Chain 0	Chain 1				
151	5755	19.65	19.95	191.112	22.81	30.00	Pass
159	5795	20.91	21.21	255.44	24.07	30.00	Pass

##### 802.11ac (VHT80)

Chan.	Chan. Freq. (MHz)	Maximum Conducted Power (dBm)		Total Power (mW)	Total Power (dBm)	Limit (dBm)	Pass / Fail
		Chain 0	Chain 1				
155	5775	17.52	17.42	111.702	20.48	30.00	Pass

## 4.4 Occupied Bandwidth Measurement

### 4.4.1 Test Setup



### 4.4.2 Test Instruments

Refer to section 4.1.2 to get information of above instrument.

### 4.4.3 Test Procedure

The transmitter output was connected to the spectrum analyzer through an attenuator. The bandwidth of the fundamental frequency was measured by spectrum analyzer with resolution bandwidth in the range of 1% to 5% of the anticipated emission bandwidth, and a video bandwidth at least 3x the resolution bandwidth and set the detector to SAMPLE. The width of a frequency band such that, below the lower and above the upper frequency limits, the mean powers emitted are each equal to a specified percentage 0.5 %of the total mean power of a given emission.

## 4.4.4 Test Results

## 802.11a

Channel	Channel Frequency (MHz)	Occupied Bandwidth (MHz)	
		Chain 0	Chain 1
36	5180	17.04	17.28
40	5200	17.16	17.64
48	5240	18.96	18.96
149	5745	28.80	28.56
157	5785	29.04	28.56
165	5825	28.20	27.96

## 802.11ac (VHT20)

Channel	Channel Frequency (MHz)	Occupied Bandwidth (MHz)	
		Chain 0	Chain 1
36	5180	18.24	18.00
40	5200	18.48	18.24
48	5240	18.84	19.56
149	5745	29.76	28.80
157	5785	29.16	28.08
165	5825	28.80	28.32

## 802.11ac (VHT40)

Channel	Channel Frequency (MHz)	Occupied Bandwidth (MHz)	
		Chain 0	Chain 1
38	5190	36.72	36.72
46	5230	37.20	36.96
151	5755	53.28	59.52
159	5795	57.60	57.36

## 802.11ac (VHT80)

Channel	Channel Frequency (MHz)	Occupied Bandwidth (MHz)	
		Chain 0	Chain 1
42	5210	75.36	75.84
155	5775	76.32	76.32

### Spectrum Plot of Worst Value

**802.11a / Chain 0 : CH157**

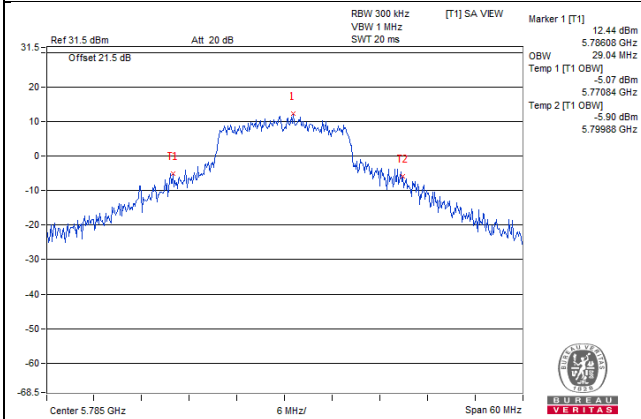

**802.11ac (VHT20) / Chain 0 : CH149**

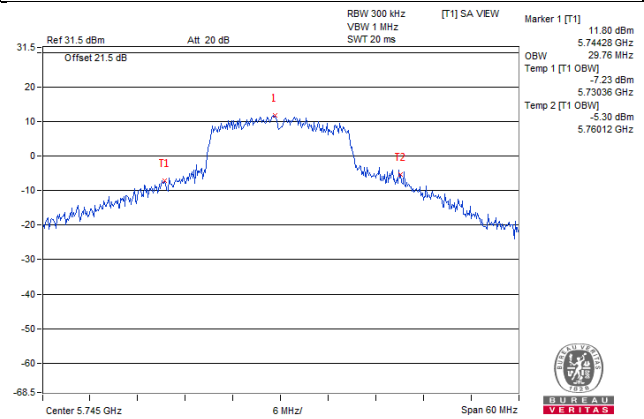

**802.11ac (VHT40) / Chain 1 : CH151**

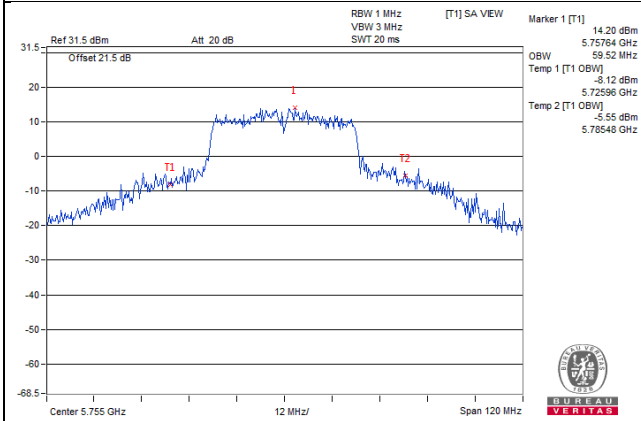

**802.11ac (VHT80) / Chain 0 : CH155**

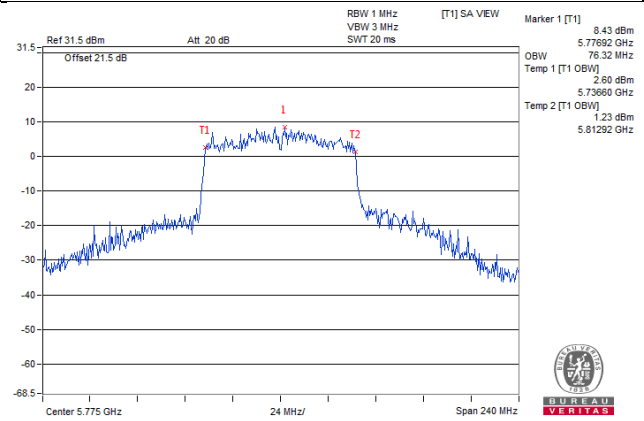

### Spectrum Plot for near by DFS band (DFS is required, if 99% OCP straddle into U-NII-2A band)

**802.11a\_Chain0 / CH48**

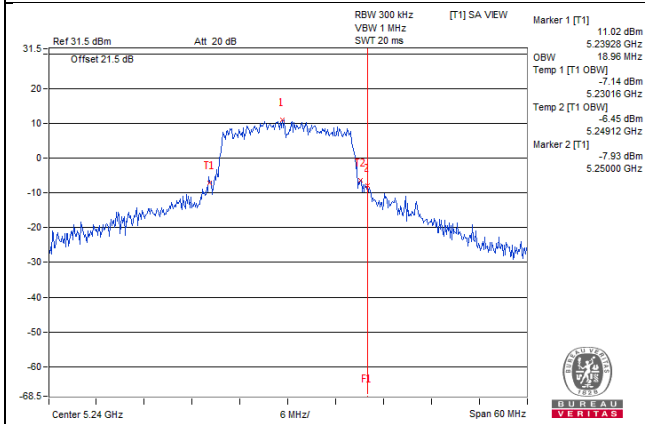

**802.11a\_Chain1 / CH48**

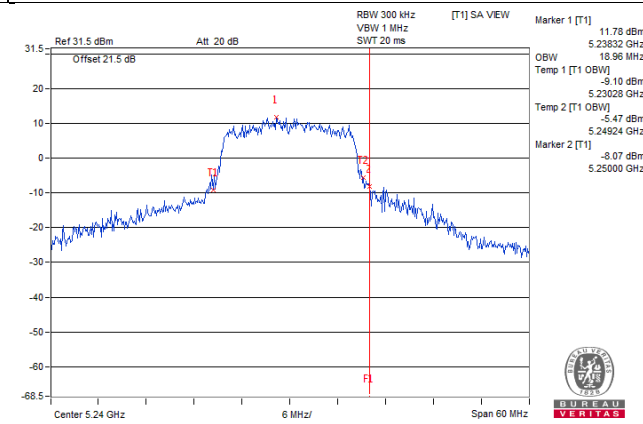

**802.11ac(VHT20)\_Chain0 / CH48**

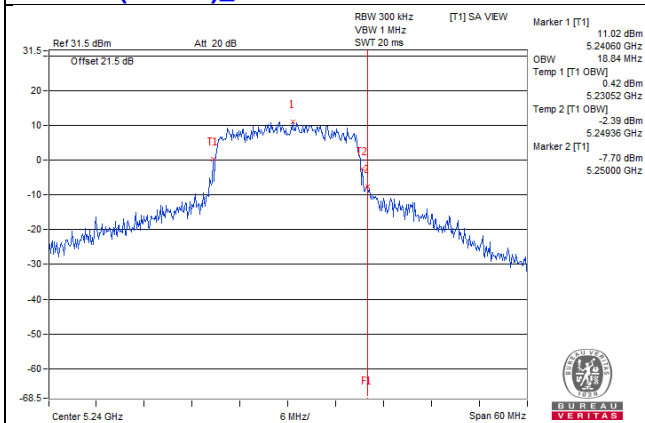

**802.11ac(VHT20)\_Chain1 / CH48**

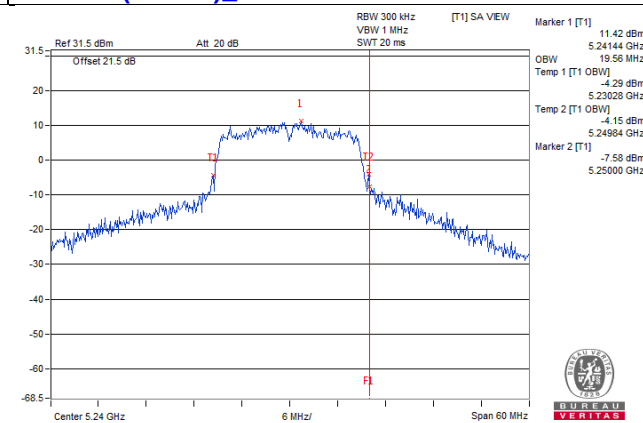

**802.11ac(VHT40)\_Chain0 / CH46**

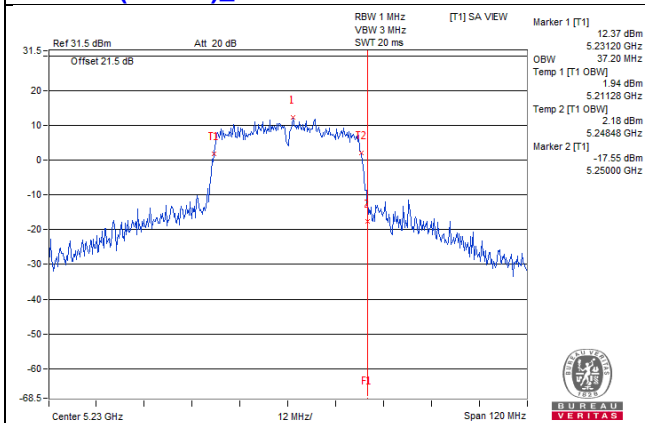

**802.11ac(VHT40)\_Chain1 / CH46**

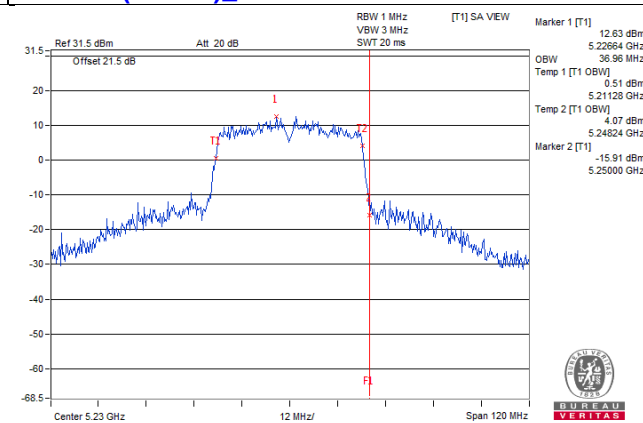

**802.11ac(VHT80)\_Chain0 / CH42**

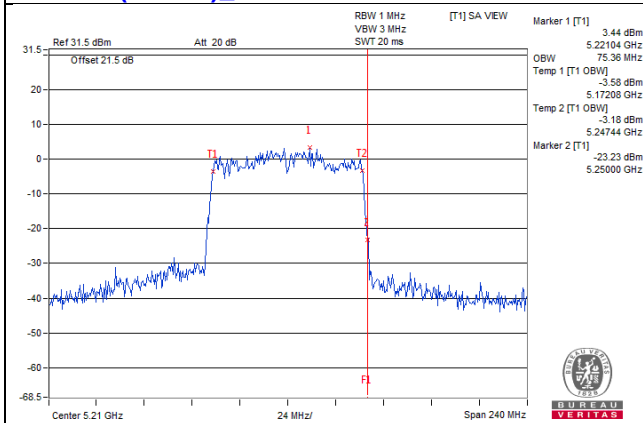

**802.11ac(VHT80)\_Chain1 / CH42**

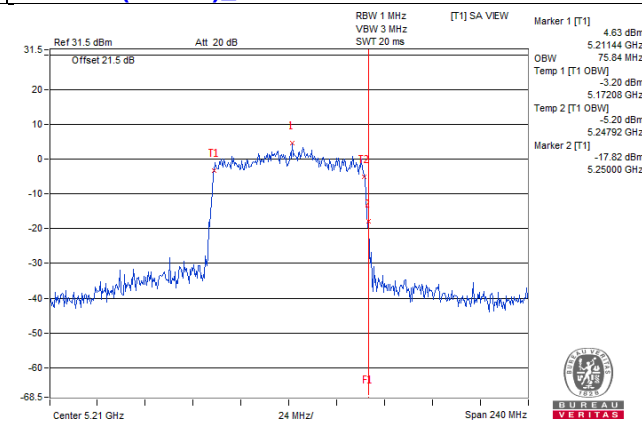

**Spectrum Plot for near by DFS band  
(DFS is required, if 99% OCP straddle into U-NII-2C band)**

**802.11a\_Chain0 / CH149**

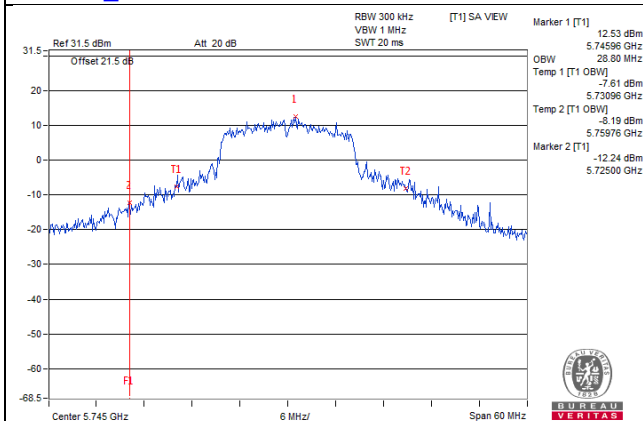

**802.11a\_Chain1 / CH149**

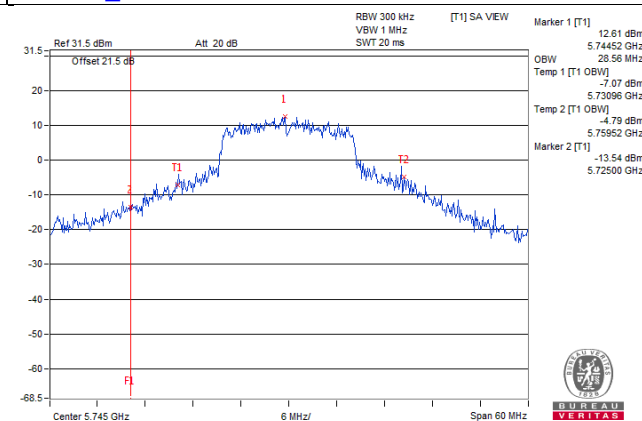

**802.11ac(VHT20)\_Chain0 / CH149**

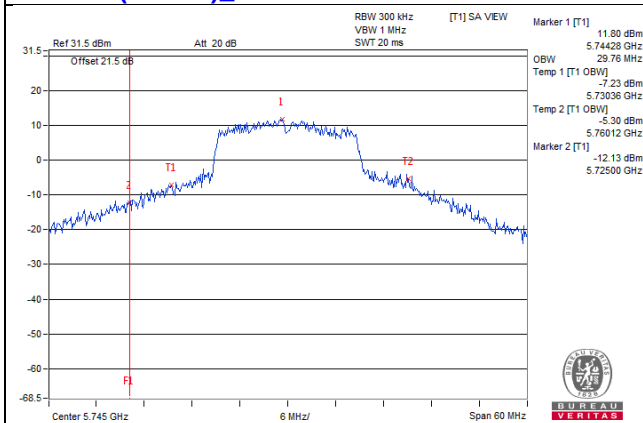

**802.11ac(VHT20)\_Chain1 / CH149**

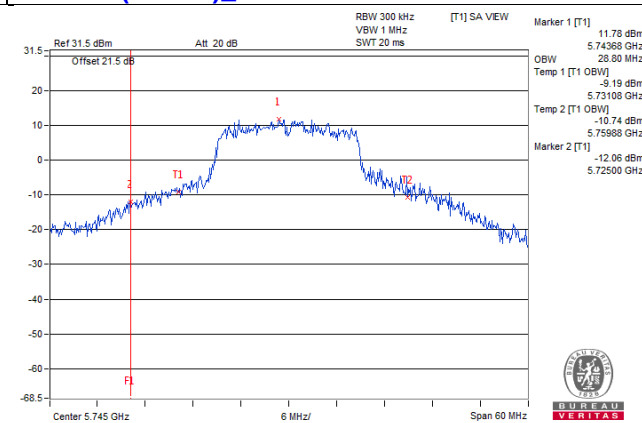

### 802.11ac(VHT40)\_Chain0 / CH151

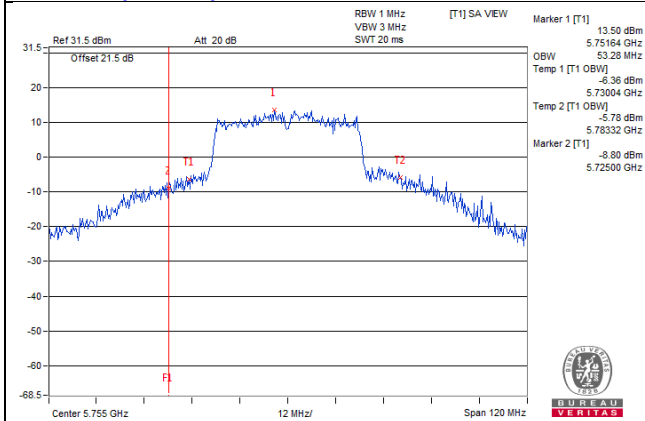

### 802.11ac(VHT40)\_Chain1 / CH151

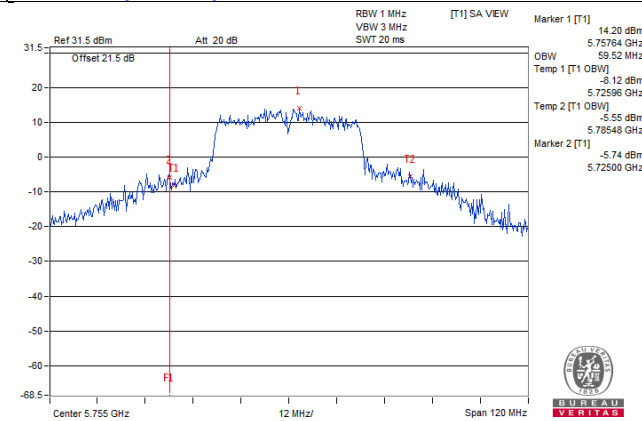

### 802.11ac(VHT80)\_Chain0 / CH155

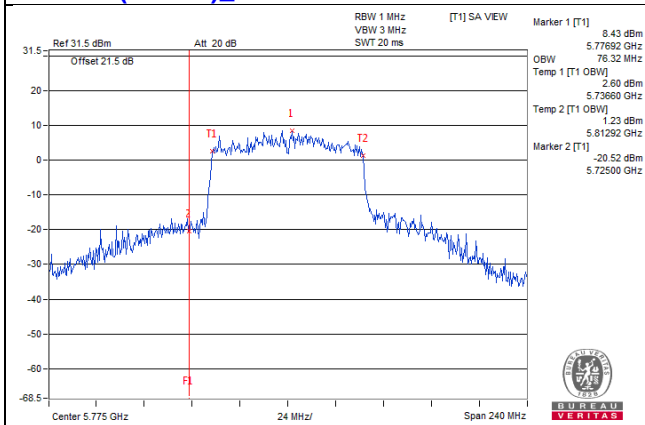

### 802.11ac(VHT80)\_Chain1 / CH155

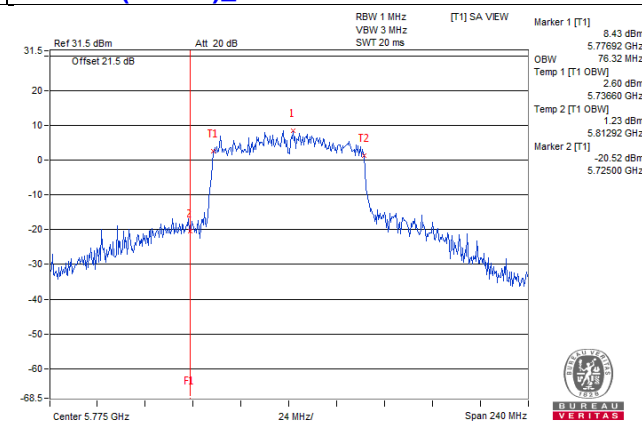



## 4.5 Peak Power Spectral Density Measurement

### 4.5.1 Limits of Peak Power Spectral Density Measurement

Operation Band	EUT Category		Limit
U-NII-1		Outdoor Access Point	17dBm/ MHz
		Fixed point-to-point Access Point	
		Indoor Access Point	
	√	Client device	11dBm/ MHz
U-NII-2A			11dBm/ MHz
U-NII-2C			11dBm/ MHz
U-NII-3		√	30dBm/ 500kHz

### 4.5.2 Test Setup



### 4.5.3 Test Instruments

Refer to section 4.1.2 to get information of above instrument.

### 4.5.4 Test Procedure

#### For U-NII-1:

Using method SA-2

1. Set span to encompass the entire emission bandwidth (EBW) of the signal.
2. Set RBW = 1 MHz, Set VBW ≥ 3 MHz, Detector = RMS
3. Sweep time = auto, trigger set to "free run".
4. Trace average at least 100 traces in power averaging mode.
5. Record the max value and add 10 log (1/duty cycle)

#### For U-NII-3:

1. Set span to encompass the entire emission bandwidth (EBW) of the signal.
2. Set RBW = 300 kHz, Set VBW ≥ 1 MHz, Detector = RMS
3. Use the peak marker function to determine the maximum power level in any 300 kHz band segment within the fundamental EBW.
4. Scale the observed power level to an equivalent value in 500 kHz by adjusting (reducing) the measured power by a bandwidth correction factor (BWCF) where  $BWCF = 10\log(500\text{ kHz}/300\text{ kHz})$
5. Sweep time = auto, trigger set to "free run".
6. Trace average at least 100 traces in power averaging mode.
7. Record the max value and add 10 log (1/duty cycle)

#### 4.5.5 Deviation from Test Standard

No deviation.

#### 4.5.6 EUT Operating Condition

Same as Item 4.2.6.

#### 4.5.7 Test Results

#### For U-NII-1:

#### 802.11a

Chan.	Chan. Freq. (MHz)	PSD W/O Duty Factor (dBm/MHz)		Duty Factor (dB)	Total PSD With Duty Factor (dBm/MHz)	MAX. Limit (dBm/MHz)	Pass / Fail
		Chain 0	Chain 1				
36	5180	4.72	2.30	0.36	7.05	10.04	Pass
40	5200	5.44	4.98	0.36	8.59	10.04	Pass
48	5240	5.96	6.16	0.36	9.43	10.04	Pass

- Note:**
- Method a) of power density measurement of KDB 662911 is using for calculating total power density. Total power density is summing entire spectra across corresponding frequency bins on the various outputs by computer.
  - Directional gain =  $10 \log[(10^{G0/20} + 10^{G1/20})^2 / 2] = 6.96 < 6\text{dBi}$  , so the power density limit shall be reduced to  $11-(6.96-6) = 10.04\text{dBm}$ .
  - Refer to section 3.3 for duty cycle spectrum plot.

#### 802.11ac (VHT20)

Chan.	Chan. Freq. (MHz)	PSD W/O Duty Factor (dBm/MHz)		Duty Factor (dB)	Total PSD With Duty Factor (dBm/MHz)	MAX. Limit (dBm/MHz)	Pass / Fail
		Chain 0	Chain 1				
36	5180	2.96	3.48	0.36	6.60	10.04	Pass
40	5200	4.60	5.56	0.36	8.48	10.04	Pass
48	5240	6.25	6.28	0.36	9.64	10.04	Pass

- Note:**
- Method a) of power density measurement of KDB 662911 is using for calculating total power density. Total power density is summing entire spectra across corresponding frequency bins on the various outputs by computer.
  - Directional gain =  $10 \log[(10^{G0/20} + 10^{G1/20})^2 / 2] = 6.96 < 6\text{dBi}$  , so the power density limit shall be reduced to  $11-(6.96-6) = 10.04\text{dBm}$ .
  - Refer to section 3.3 for duty cycle spectrum plot.

### 802.11ac (VHT40)

Chan.	Chan. Freq. (MHz)	PSD W/O Duty Factor (dBm/MHz)		Duty Factor (dB)	Total PSD With Duty Factor (dBm/MHz)	MAX. Limit (dBm/MHz)	Pass / Fail
		Chain 0	Chain 1				
38	5190	-5.34	-3.54	0.63	-0.71	10.04	Pass
46	5230	-1.46	-0.18	0.63	2.87	10.04	Pass

- Note:**
- Method a) of power density measurement of KDB 662911 is using for calculating total power density. Total power density is summing entire spectra across corresponding frequency bins on the various outputs by computer.
  - Directional gain =  $10 \log[(10^{G_0/20} + 10^{G_1/20})^2 / 2] = 6.96 < 6\text{dBi}$  , so the power density limit shall be reduced to  $11-(6.96-6) = 10.04\text{dBm}$ .
  - Refer to section 3.3 for duty cycle spectrum plot.

### 802.11ac (VHT80)

Chan.	Chan. Freq. (MHz)	PSD W/O Duty Factor (dBm/MHz)		Duty Factor (dB)	Total PSD With Duty Factor (dBm/MHz)	MAX. Limit (dBm/MHz)	Pass / Fail
		Chain 0	Chain 1				
42	5210	-10.46	-11.72	1.24	-6.79	10.04	Pass

- Note:**
- Method a) of power density measurement of KDB 662911 is using for calculating total power density. Total power density is summing entire spectra across corresponding frequency bins on the various outputs by computer.
  - Directional gain =  $10 \log[(10^{G_0/20} + 10^{G_1/20})^2 / 2] = 6.96 < 6\text{dBi}$  , so the power density limit shall be reduced to  $11-(6.96-6) = 10.04\text{dBm}$ .
  - Refer to section 3.3 for duty cycle spectrum plot.

Spectrum Plot of Worst Value

802.11a / Chain 1 : CH48

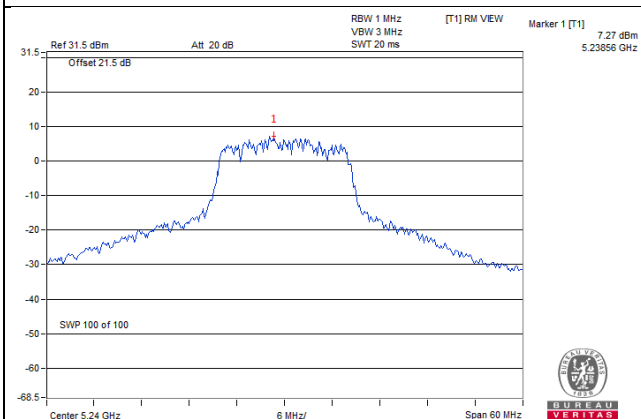

802.11ac (VHT20) / Chain 1 : CH48

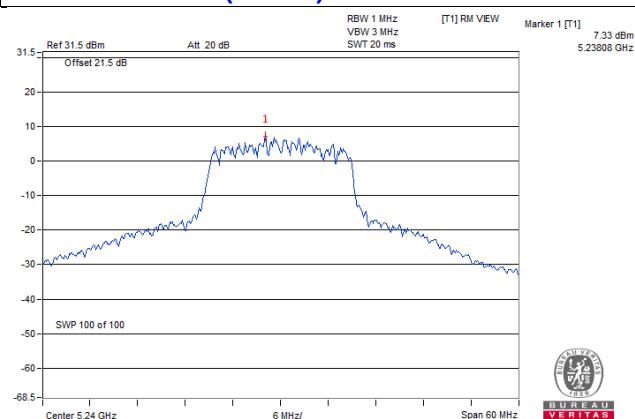

802.11ac (VHT40) / Chain 1 : CH46

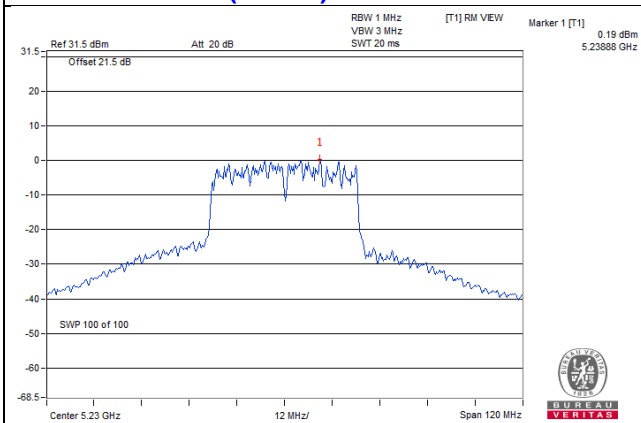

802.11ac (VHT80) / Chain 0 : CH42

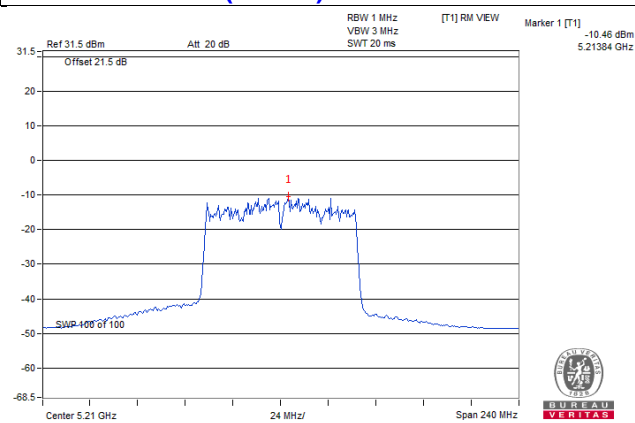

**For U-NII-3:**
**802.11a**

TX chain	Chan.	Chan. Freq. (MHz)	PSD W/O Duty Factor		10 log (N=2) dB	Duty Factor (dB)	Total PSD With Duty Factor (dBm/500kHz)	Limit (dBm/500kHz)	Pass /Fail
			(dBm/300kHz)	(dBm/500kHz)					
0	149	5745	-0.67	1.55	3.01	0.36	4.92	28.48	Pass
	157	5785	-0.91	1.31	3.01	0.36	4.68	28.48	Pass
	165	5825	-0.64	1.58	3.01	0.36	4.95	28.48	Pass
1	149	5745	-1.18	1.04	3.01	0.36	4.41	28.48	Pass
	157	5785	-1.18	1.04	3.01	0.36	4.41	28.48	Pass
	165	5825	-0.33	1.89	3.01	0.36	5.26	28.48	Pass

**Note:** 1. Directional gain =  $10 \log[(10^{G0/20} + 10^{G1/20})^2 / 2] = 7.52 < 6\text{dBi}$  , so the power density limit shall be reduced to  $30-(7.52-6) = 28.48\text{dBm}$ .

3. Refer to section 3.3 for duty cycle spectrum plot.

**802.11ac (VHT20)**

TX chain	Chan.	Chan. Freq. (MHz)	PSD W/O Duty Factor		10 log (N=2) dB	Duty Factor (dB)	Total PSD With Duty Factor (dBm/500kHz)	Limit (dBm/500kHz)	Pass /Fail
			(dBm/300kHz)	(dBm/500kHz)					
0	149	5745	-1.33	0.89	3.01	0.25	4.26	28.48	Pass
	157	5785	-1.13	1.09	3.01	0.25	4.46	28.48	Pass
	165	5825	-1.16	1.06	3.01	0.25	4.43	28.48	Pass
1	149	5745	-1.17	1.05	3.01	0.25	4.42	28.48	Pass
	157	5785	-1.99	0.23	3.01	0.25	3.60	28.48	Pass
	165	5825	-1.32	0.90	3.01	0.25	4.27	28.48	Pass

**Note:** 1. Directional gain =  $10 \log[(10^{G0/20} + 10^{G1/20})^2 / 2] = 7.52 < 6\text{dBi}$  , so the power density limit shall be reduced to  $30-(7.52-6) = 28.48\text{dBm}$ .

3. Refer to section 3.3 for duty cycle spectrum plot.

### 802.11ac (VHT40)

TX chain	Chan.	Chan. Freq. (MHz)	PSD W/O Duty Factor		10 log (N=2) dB	Duty Factor (dB)	Total PSD With Duty Factor (dBm/500kHz)	Limit (dBm/500kHz)	Pass /Fail
			(dBm/300kHz)	(dBm/500kHz)					
0	151	5755	-6.41	-4.19	3.01	0.63	-0.55	28.48	Pass
	159	5795	-6.24	-4.02	3.01	0.63	-0.38	28.48	Pass
1	151	5755	-6.13	-3.91	3.01	0.63	-0.27	28.48	Pass
	159	5795	-6.37	-4.15	3.01	0.63	-0.51	28.48	Pass

**Note:** 1. Directional gain =  $10 \log[(10^{G0/20} + 10^{G1/20})^2 / 2] = 7.52 < 6\text{dBi}$  , so the power density limit shall be reduced to  $30-(7.52-6) = 28.48\text{dBm}$ .

3. Refer to section 3.3 for duty cycle spectrum plot.

### 802.11ac (VHT80)

TX chain	Chan.	Chan. Freq. (MHz)	PSD W/O Duty Factor		10 log (N=2) dB	Duty Factor (dB)	Total PSD With Duty Factor (dBm/500kHz)	Limit (dBm/500kHz)	Pass /Fail
			(dBm/300kHz)	(dBm/500kHz)					
0	155	5775	-11.24	-9.02	3.01	1.24	-4.77	28.48	Pass
1	155	5775	-11.24	-9.02	3.01	1.24	-4.77	28.48	Pass

**Note:** 1. Directional gain =  $10 \log[(10^{G0/20} + 10^{G1/20})^2 / 2] = 7.52 < 6\text{dBi}$  , so the power density limit shall be reduced to  $30-(7.52-6) = 28.48\text{dBm}$ .

3. Refer to section 3.3 for duty cycle spectrum plot.

Spectrum Plot of Worst Value

802.11a / Chain 1 : CH165

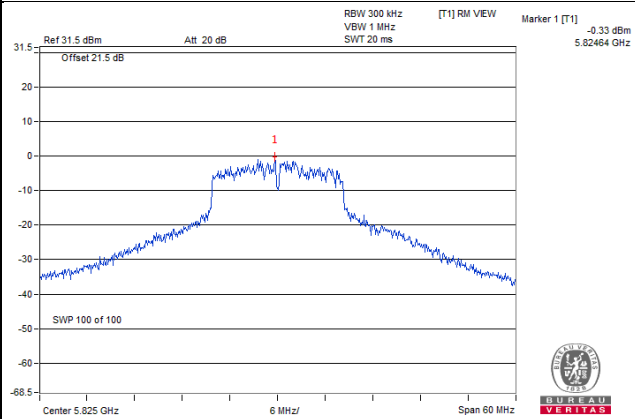

802.11ac (VHT20) / Chain 0 : CH157

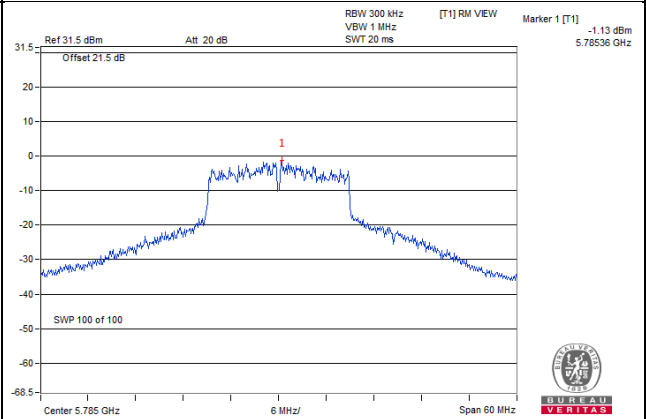

802.11ac (VHT40) / Chain 1 : CH151

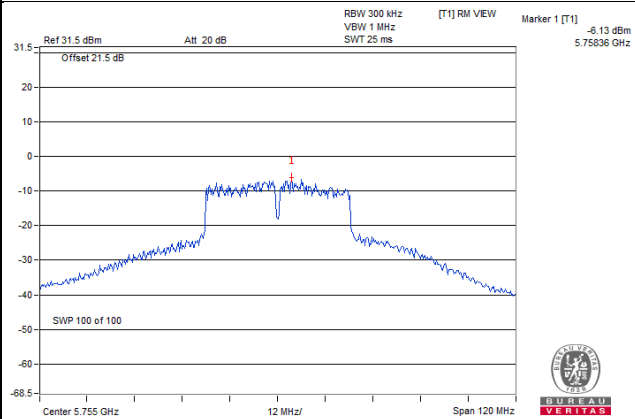

802.11ac (VHT80) / Chain 0 : CH155

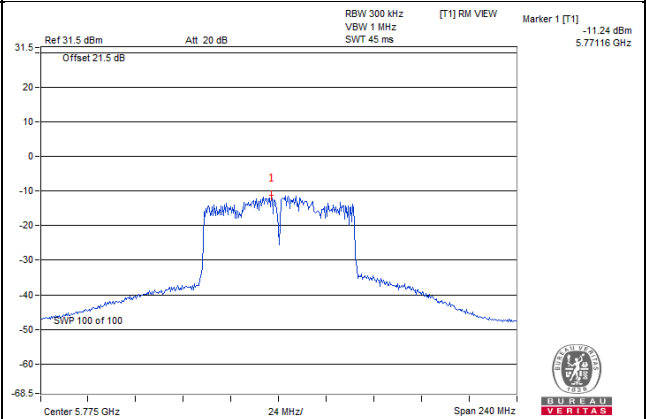



## 4.6 Frequency Stability Measurement

### 4.6.1 Limits of Frequency Stability Measurement

The frequency of the carrier signal shall be maintained within band of operation

### 4.6.2 Test Setup

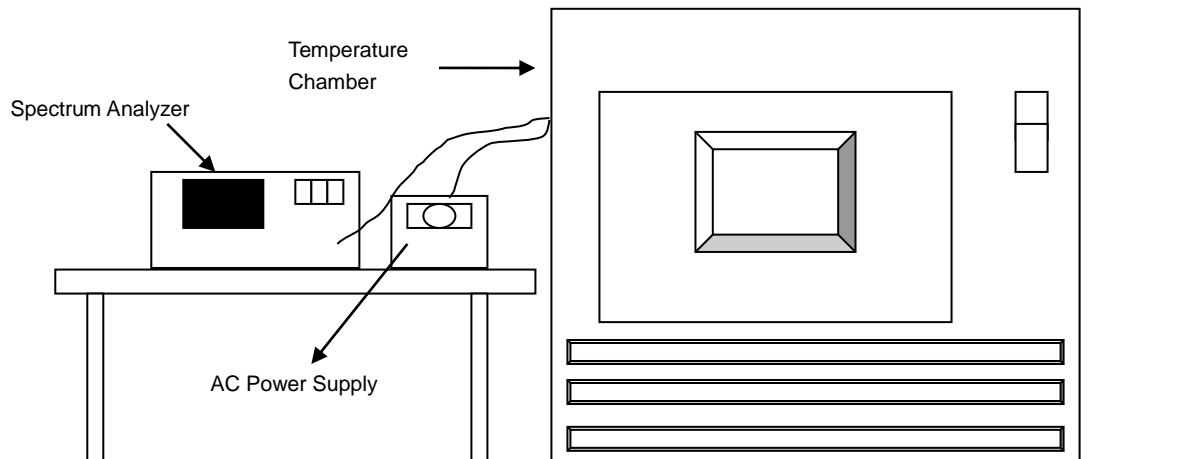

### 4.6.3 Test Instruments

Refer to section 4.1.2 to get information of above instrument.

### 4.6.4 Test Procedure

- The EUT was placed inside the environmental test chamber and powered by nominal AC voltage.
- Turn the EUT on and couple its output to a spectrum analyzer.
- Turn the EUT off and set the chamber to the highest temperature specified.
- Allow sufficient time (approximately 30 min) for the temperature of the chamber to stabilize, turn the EUT on and measure the operating frequency after 2, 5, and 10 Minutes.
- Repeat step 2 and 3 with the temperature chamber set to the lowest temperature.
- The test chamber was allowed to stabilize at +20 degree C for a minimum of 30 Minutes. The supply voltage was then adjusted on the EUT from 85% to 115% and the frequency record.

### 4.6.5 Deviation from Test Standard

No deviation.

### 4.6.6 EUT Operating Condition

Set the EUT transmit at un-modulation mode to test frequency stability.

#### 4.6.7 Test Results

Frequency Stability Versus Temp.									
Operating Frequency: 5180 MHz									
TEMP. (°C)	Power Supply (Vac)	0 Minute		2 Minutes		5 Minutes		10 Minutes	
		Measured Frequency (MHz)	Pass/Fail	Measured Frequency (MHz)	Pass/Fail	Measured Frequency (MHz)	Pass/Fail	Measured Frequency (MHz)	Pass/Fail
50	120	5180.0122	PASS	5180.0125	PASS	5180.0135	PASS	5180.0129	PASS
40	120	5180.0022	PASS	5180.0023	PASS	5180.0052	PASS	5180.0024	PASS
30	120	5180.0101	PASS	5180.0099	PASS	5180.0122	PASS	5180.0115	PASS
20	120	5180.0188	PASS	5180.0225	PASS	5180.0232	PASS	5180.0194	PASS
10	120	5179.9724	PASS	5179.9749	PASS	5179.9724	PASS	5179.9739	PASS
0	120	5179.9772	PASS	5179.9735	PASS	5179.9742	PASS	5179.9771	PASS
-10	120	5179.9996	PASS	5179.9995	PASS	5179.9984	PASS	5180.0015	PASS
-20	120	5180.0078	PASS	5180.012	PASS	5180.0093	PASS	5180.0103	PASS
-30	120	5180.0108	PASS	5180.0092	PASS	5180.0085	PASS	5180.0101	PASS

Frequency Stability Versus Voltage									
Operating Frequency: 5180 MHz									
TEMP. (°C)	Power Supply (Vac)	0 Minute		2 Minutes		5 Minutes		10 Minutes	
		Measured Frequency (MHz)	Pass/Fail	Measured Frequency (MHz)	Pass/Fail	Measured Frequency (MHz)	Pass/Fail	Measured Frequency (MHz)	Pass/Fail
20	138	5180.0179	PASS	5180.0228	PASS	5180.0241	PASS	5180.0184	PASS
	120	5180.0188	PASS	5180.0225	PASS	5180.0232	PASS	5180.0194	PASS
	102	5180.0185	PASS	5180.0229	PASS	5180.0233	PASS	5180.0187	PASS

## 4.7 6dB Bandwidth Measurement

### 4.7.1 Limits of 6dB Bandwidth Measurement

The minimum of 6dB Bandwidth Measurement is 0.5MHz.

### 4.7.2 Test Setup

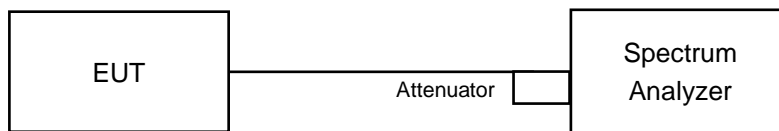

### 4.7.3 Test Instruments

Refer to section 4.1.2 to get information of above instrument.

### 4.7.4 Test Procedure

#### MEASUREMENT PROCEDURE REF

- a. Set resolution bandwidth (RBW) = 100kHz
- b. Set the video bandwidth (VBW)  $\geq 3 \times$  RBW, Detector = Peak.
- c. Trace mode = max hold.
- d. Sweep = auto couple.
- e. Measure the maximum width of the emission that is constrained by the frequencies associated with the two amplitude points (upper and lower) that are attenuated by 6 dB relative to the maximum level measured in the fundamental emission

### 4.7.5 Deviation from Test Standard

No deviation.

### 4.7.6 EUT Operating Condition

The software provided by client to enable the EUT under transmission condition continuously at lowest, middle and highest channel frequencies individually.

#### 4.7.7 Test Results

##### 802.11a

Channel	Frequency (MHz)	6dB Bandwidth (MHz)		Minimum Limit (MHz)	Pass / Fail
		Chain 0	Chain 1		
149	5745	15.48	15.57	0.5	PASS
157	5785	15.44	16.02	0.5	PASS
165	5825	16.05	15.74	0.5	PASS

##### 802.11ac (VHT20)

Channel	Frequency (MHz)	6dB Bandwidth (MHz)		Minimum Limit (MHz)	Pass / Fail
		Chain 0	Chain 1		
149	5745	16.62	16.67	0.5	PASS
157	5785	16.26	16.93	0.5	PASS
165	5825	17.06	16.67	0.5	PASS

##### 802.11ac (VHT40)

Channel	Frequency (MHz)	6dB Bandwidth (MHz)		Minimum Limit (MHz)	Pass / Fail
		Chain 0	Chain 1		
151	5755	36.42	35.78	0.5	PASS
159	5795	36.34	36.11	0.5	PASS

##### 802.11ac (VHT80)

Channel	Frequency (MHz)	6dB Bandwidth (MHz)		Minimum Limit (MHz)	Pass / Fail
		Chain 0	Chain 1		
155	5775	75.53	75.54	0.5	PASS

Spectrum Plot of Worst Value

802.11a / Chain 0 : CH157

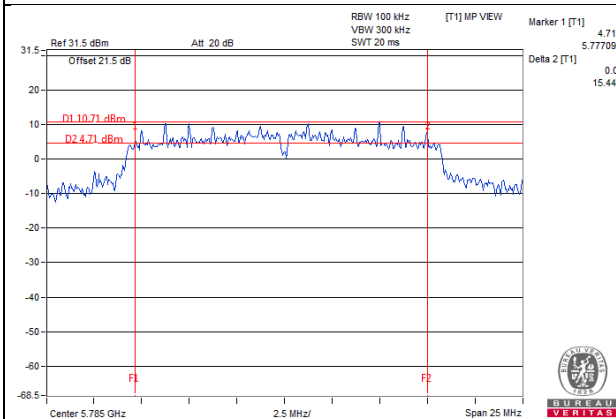

802.11ac (VHT20) / Chain 0 : CH157

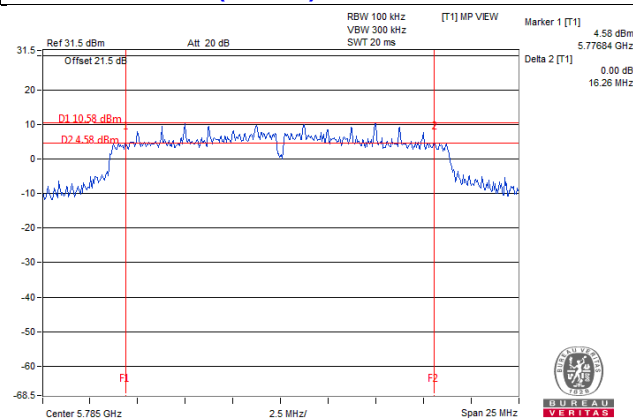

802.11ac (VHT40) / Chain 1 : CH151

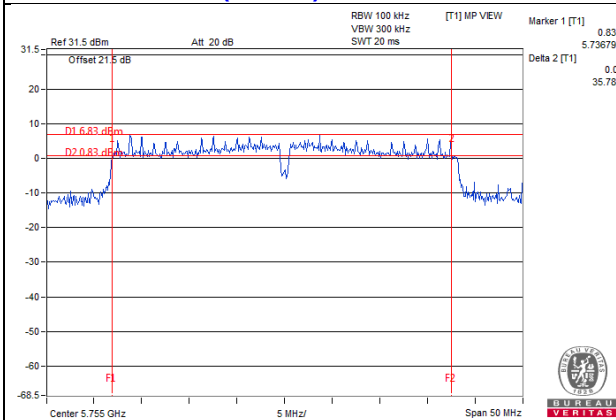

802.11ac (VHT80) / Chain 0 : CH155

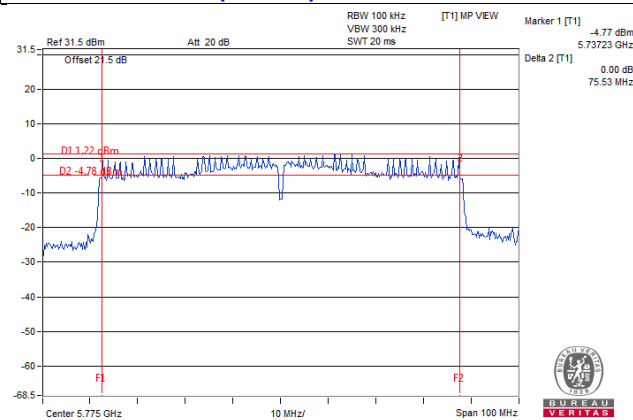

## 5 Pictures of Test Arrangements

Please refer to the attached file (Test Setup Photo).

### Annex A- Radiated Out of Band Emission (OOBE) Measurement (For U-NII-3 band)

802.11a

**CH 149 5745 MHz**

**Horizontal**

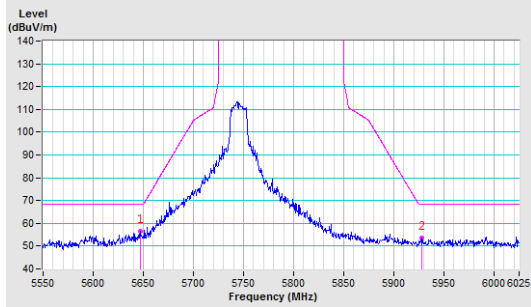

**Vertical**

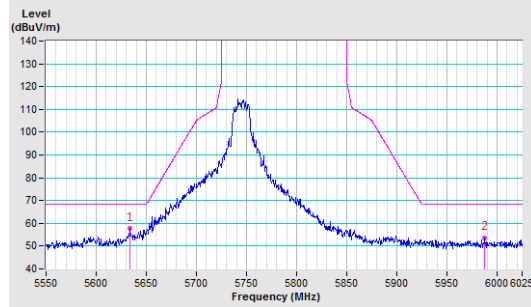

**CH 157 5785 MHz**

**Horizontal**

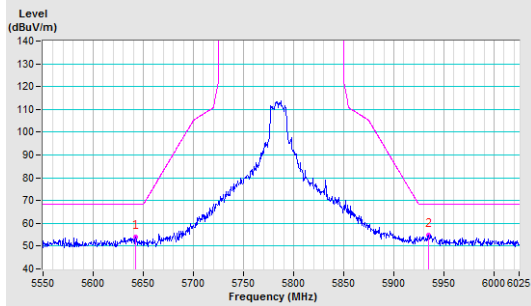

**Vertical**

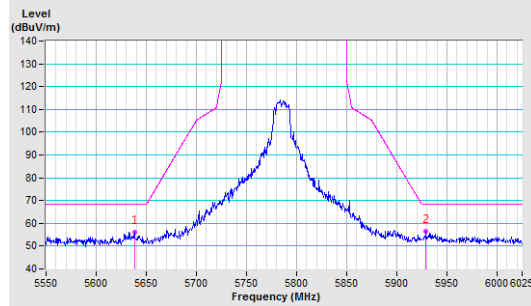

**CH 165 5825 MHz**

**Horizontal**

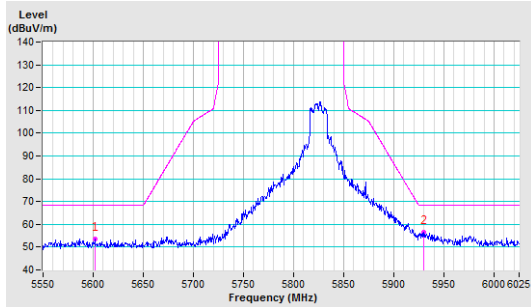

**Vertical**

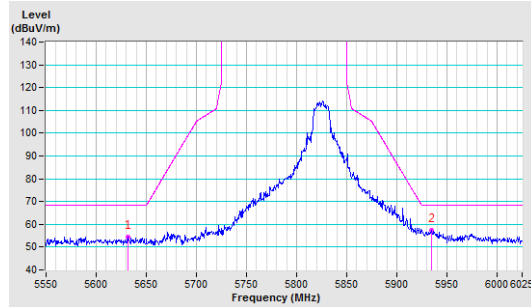

802.11ac (VHT20)

CH 149 5745 MHz

Horizontal

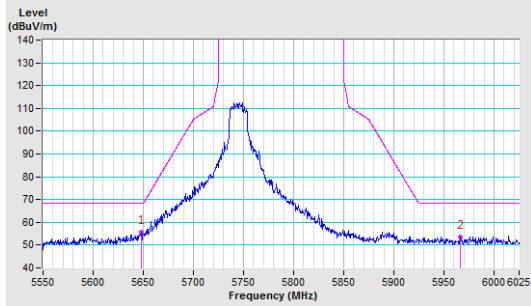

Vertical

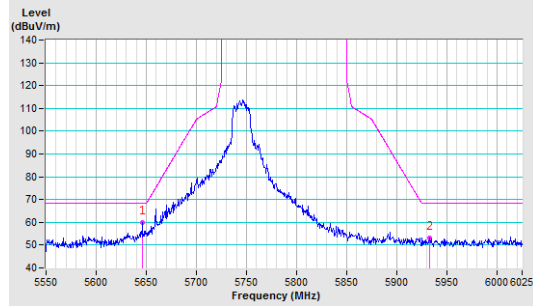

CH 157 5785 MHz

Horizontal

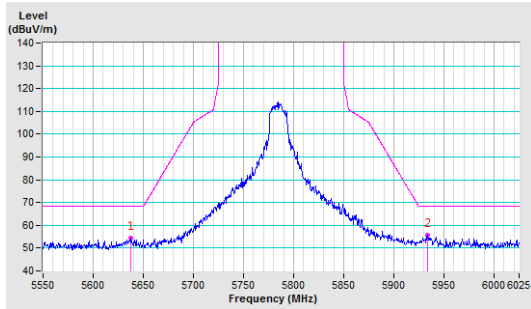

Vertical

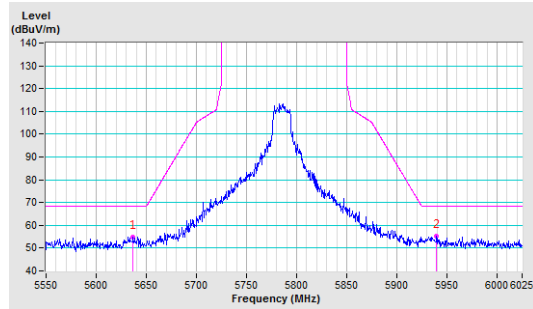

CH 165 5825 MHz

Horizontal

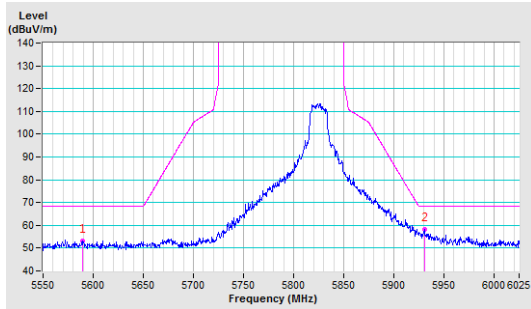

Vertical

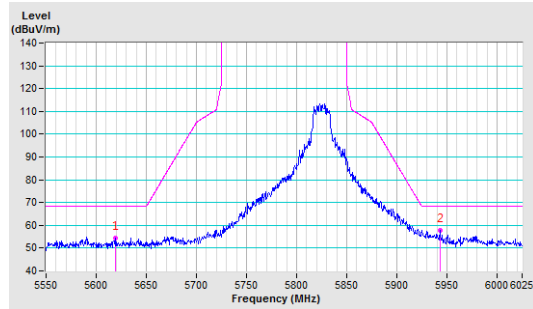



802.11ac (VHT40)

CH 151 5755 MHz

Horizontal

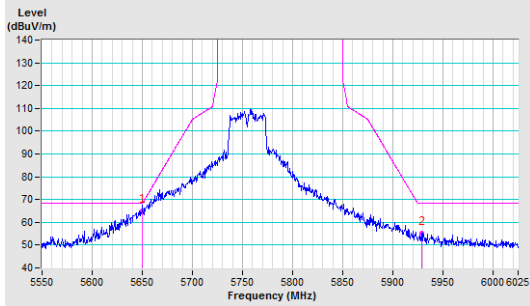

Vertical

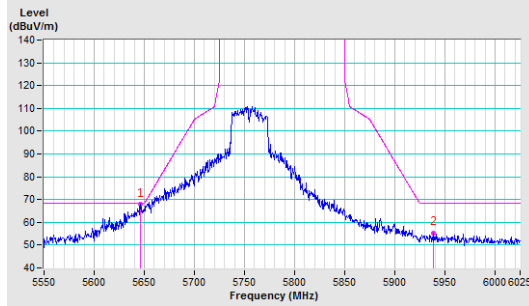

CH 159 5795 MHz

Horizontal

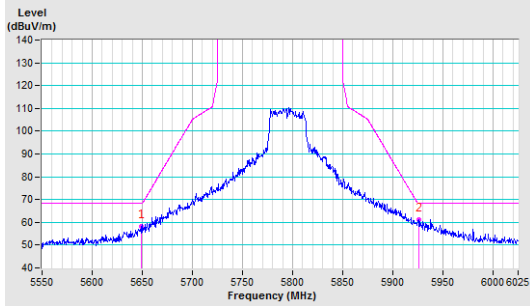

Vertical

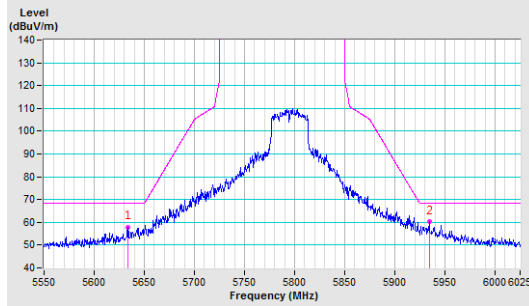

802.11ac (VHT80)

CH 155 5775 MHz

Horizontal

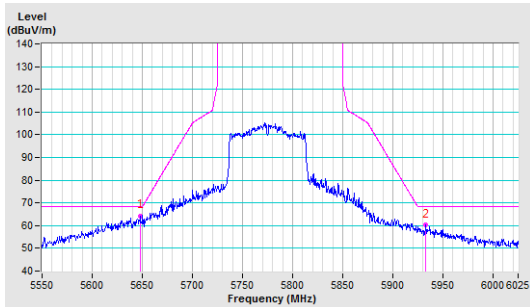

Vertical

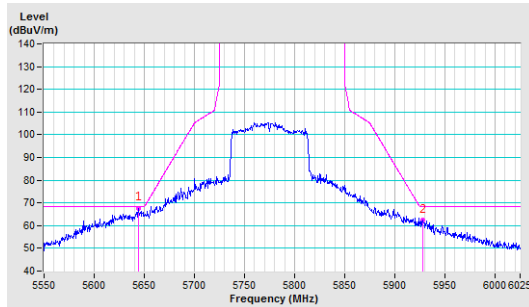

## Appendix – Information on the Testing Laboratories

We, Bureau Veritas Consumer Products Services (H.K.) Ltd., Taoyuan Branch, were founded in 1988 to provide our best service in EMC, Radio, Telecom and Safety consultation. Our laboratories are FCC recognized accredited test firms and accredited according to ISO/IEC 17025.

If you have any comments, please feel free to contact us at the following:

**Linko EMC/RF Lab**

Tel: 886-2-26052180

Fax: 886-2-26051924

**Hsin Chu EMC/RF/Telecom Lab**

Tel: 886-3-6668565

Fax: 886-3-6668323

**Hwa Ya EMC/RF/Safety Lab**

Tel: 886-3-3183232

Fax: 886-3-3270892

**Email:** [service.adt@tw.bureauveritas.com](mailto:service.adt@tw.bureauveritas.com)

**Web Site:** [www.bureauveritas-adt.com](http://www.bureauveritas-adt.com)

The address and road map of all our labs can be found in our web site also.

--- END ---