



SPORTON International Inc.

No. 52, Hwa Ya 1st Rd., Hwa Ya Technology Park, Kwei-Shan Hsiang, Tao Yuan Hsien, Taiwan, R.O.C.
Ph: 886-3-327-3456 / FAX: 886-3-327-0973 / www.sporton.com.tw

FCC RADIO TEST REPORT

Applicant's company	SunPower Corporation
Applicant Address	1414 Harbour Way South Suite 1901, Richmond, CA 94804, USA
FCC ID	YAW522350L
Manufacturer's company (1)	Zyxel Communications Corporation
Manufacturer Address (1)	No.2 Industry East RD. IX, Hsinchu Science Park, Hsinchu 30075, Taiwan
Manufacturer's company (2)	MitraStar Technology Corporation
Manufacturer Address (2)	No. 6, Innovation Rd II, Science-Based Industrial, Hsin-Chu, Taiwan
Manufacturer's company (3)	Wuxi MitraStar Technology Co. Ltd
Manufacturer Address (3)	1-1# Minshan Road, Wuxi New Wu District, Jiangsu, China

Product Name	SunPower Monitoring System with PVS5x
Brand Name	SUNPOWER
Model No.	PVS5x
Test Rule	47 CFR FCC Part 15 Subpart C § 15.247
Test Freq. Range	2400~2483.5 MHz
Received Date	Jun. 26, 2015
Final Test Date	Feb. 01, 2018
Submission Type	Original Equipment

Statement

Test result included is only for the IEEE 802.15.4 ZigBee of the product.

The test result in this report refers exclusively to the presented test model / sample.

Without written approval of SPORTON International Inc., the test report shall not be reproduced except in full.

The measurements and test results shown in this test report were made in accordance with the procedures and found in compliance with the limit given in **ANSI C63.10-2013, 47 CFR FCC Part 15 Subpart C** and **KDB558074 D01 v04**.

The test equipment used to perform the test is calibrated and traceable to NML/ROC.



Table of Contents

1. VERIFICATION OF COMPLIANCE	1
2. SUMMARY OF THE TEST RESULT	2
3. GENERAL INFORMATION	3
3.1. Product Details.....	3
3.2. Accessories.....	3
3.3. Table for Filed Antenna.....	4
3.4. Table for Carrier Frequencies	6
3.5. Table for Test Modes.....	7
3.6. Table for Testing Locations.....	7
3.7. Table for Supporting Units	8
3.8. Table for Parameters of Test Software Setting	8
3.9. EUT Operation during Test	8
3.10. Duty Cycle.....	8
3.11. Test Configurations	9
4. TEST RESULT	11
4.1. AC Power Line Conducted Emissions Measurement.....	11
4.2. Maximum Conducted Output Power Measurement.....	15
4.3. Power Spectral Density Measurement	17
4.4. 6dB Spectrum Bandwidth Measurement	21
4.5. Radiated Emissions Measurement	25
4.6. Emissions Measurement	35
4.7. Antenna Requirements	41
5. LIST OF MEASURING EQUIPMENTS	42
6. MEASUREMENT UNCERTAINTY	44
APPENDIX A. TEST PHOTOS	A1 ~ A4
PHOTOGRAPHS OF EUT V01	



History of This Test Report

REPORT NO.	VERSION	DESCRIPTION	ISSUED DATE
FR562534-01AB	Rev. 01	Initial issue of report	Mar. 05, 2018



1. VERIFICATION OF COMPLIANCE

Product Name : SunPower Monitoring System with PVS5x
Brand Name : SUNPOWER
Model No. : PVS5x
Applicant : SunPower Corporation
Test Rule Part(s) : 47 CFR FCC Part 15 Subpart C § 15.247

Sporton International as requested by the applicant to evaluate the EMC performance of the product sample received on Jun. 26, 2015 would like to declare that the tested sample has been evaluated and found to be in compliance with the tested rule parts. The data recorded as well as the test configuration specified is true and accurate for showing the sample's EMC nature.

A handwritten signature in blue ink that reads 'Sam Chen'. The signature is written in a cursive style and is positioned above a horizontal line.

Sam Chen

SPORTON INTERNATIONAL INC.

2. SUMMARY OF THE TEST RESULT

Applied Standard: 47 CFR FCC Part 15 Subpart C			
Part	Rule Section	Description of Test	Result
4.1	15.207	AC Power Line Conducted Emissions	Complies
4.2	15.247(b)(3)	Maximum Conducted Output Power	Complies
4.3	15.247(e)	Power Spectral Density	Complies
4.4	15.247(a)(2)	6dB Spectrum Bandwidth	Complies
4.5	15.247(d)	Radiated Emissions	Complies
4.6	15.247(d)	Band Edge Emissions	Complies
4.7	15.203	Antenna Requirements	Complies

3. GENERAL INFORMATION

3.1. Product Details

Items	Description
Power Type	Internal power supply
Modulation	DSSS (O-QPSK)
Data Rate (Mbps)	DSSS (250kbps)
Frequency Range	2400~2483.5 MHz
Channel Number	15
Channel Band Width (99%)	2.43 MHz
Maximum Conducted Output Power	21.29 dBm
Carrier Frequencies	Please refer to section 3.4
Antenna	Please refer to section 3.3

Note: The device contains transmitter module (FCC ID: XMR201605EC25A)

3.2. Accessories

Others
Cradle*1

3.3. Table for Filed Antenna

Ant.	Brand	P/N	Antenna Type	Connector	Gain (dBi)
1	Airgain	N2420GS2-T-PK1-B90U	PIFA Antenna	I-PEX	Note 1
2	Airgain	N2420GS2-T-PK1-G155U	PIFA Antenna	I-PEX	Note 1
3	Airgain	N2420GS2-T-PK1-B130U	PIFA Antenna	I-PEX	Note 2

Note 1:

Ant.	Gain (dBi)			
	2412 MHz	2437 MHz	2442 MHz	2462 MHz
1	4.1	4.2	3.7	4.1
2	3.2	2.8	3.0	2.8

Note 2:

Ant.	Gain (dBi)		
	2405 MHz	2440 MHz	2475 MHz
3	2.3	1.8	1.4

Note 3:

For IEEE 802.11b mode (1TX/1RX):

The EUT supports the antenna with TX and RX diversity functions.

Both Chain 1 and Chain 2 support transmit and receive functions, but only one of them will be used at one time.

The Chain 2 generated the worst case, so it was selected to test and record in the report.

For IEEE 802.11g/n mode (2TX/2RX):

Chain 1 and Chain 2 will transmit/receive the same signal simultaneously.

Chain 1 and Chain 2 can be used as transmitting/receiving antennas.

For Zigbee mode (1TX/1RX):

Chain 3 can be used as transmitting/receiving antenna.

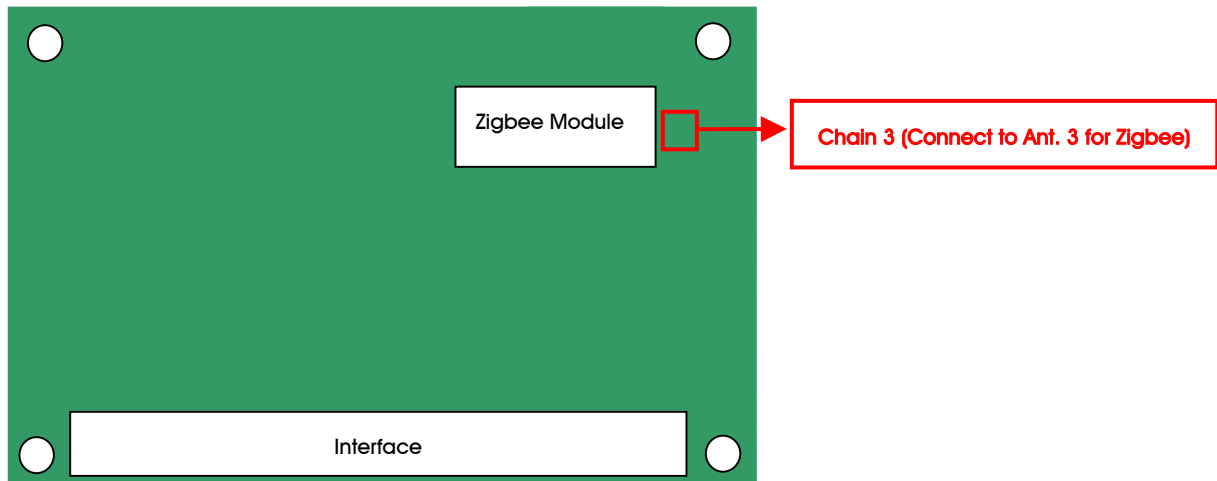
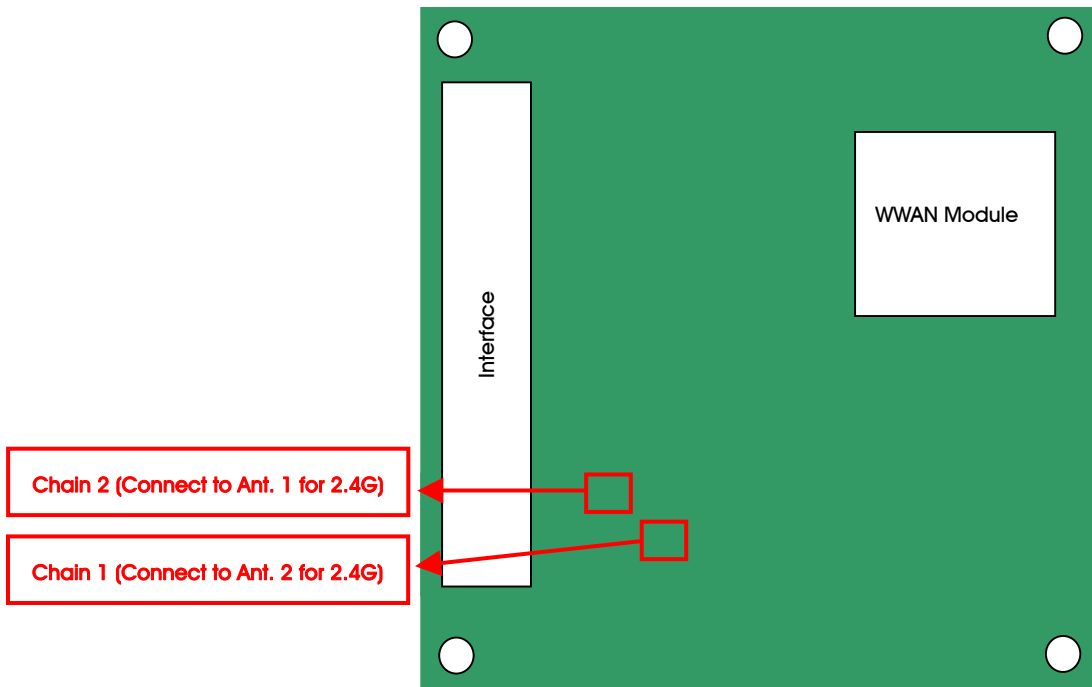

3.4. Table for Carrier Frequencies

Frequency Band	Channel No.	Frequency	Channel No.	Frequency
2400~2483.5 MHz	11	2405 MHz	19	2445 MHz
	12	2410 MHz	20	2450 MHz
	13	2415 MHz	21	2455 MHz
	14	2420 MHz	22	2460 MHz
	15	2425 MHz	23	2465 MHz
	16	2430 MHz	24	2470 MHz
	17	2435 MHz	25	2475 MHz
	18	2440 MHz	-	-

3.5. Table for Test Modes

Preliminary tests were performed in different data rate to find the worst radiated emission. The data rate shown in the table below is the worst-case rate with respect to the specific test item. Investigation has been done on all the possible configurations for searching the worst cases. The following table is a list of the test modes shown in this test report.

Test Items	Mode	Data Rate	Channel	Chain
AC Power Line Conducted Emissions	CTX	-	-	-
Maximum Conducted Output Power	TX Mode	250 kbps	11/18/25	3
Power Spectral Density 6dB Spectrum Bandwidth	TX Mode	250 kbps	11/18/25	3
Radiated Emissions 9kHz~1GHz	CTX	-	-	-
Radiated Emissions 1GHz~10 th Harmonic	TX Mode	250 kbps	11/18/25	3
Band Edge Emissions	TX Mode	250 kbps	11/18/25	3

The EUT can only be used at Y axis.

The following test modes were performed for all tests:

For Conducted Emission test:

Mode 1. CTX-EUT (WiFi + Zigbee)

For Radiated Emission below 1GHz test:

Mode 1. CTX-EUT (WiFi + Zigbee)

For Radiated Emission above 1GHz test:

Mode 1. CTX-EUT

For Co-location MPE:

The EUT could be applied with WLAN + Zigbee + WWAN (FCC ID:XMR201605EC25A); therefore Co-location Maximum Permissible Exposure (Please refer to FA562534-01).

3.6. Table for Testing Locations

Test Site Location				
Address:	No.8, Lane 724, Bo-ai St., Jhubei City, Hsinchu County 302, Taiwan, R.O.C.			
TEL:	886-3-656-9065			
FAX:	886-3-656-9085			
Test Site No.	Site Category	Location	FCC Reg. No.	IC File No.
03CH01-CB	SAC	Hsin Chu	262045	IC 4086D
CO01-CB	Conduction	Hsin Chu	262045	IC 4086D
TH01-CB	OVEN Room	Hsin Chu	-	-

Open Area Test Site (OATS); Semi Anechoic Chamber (SAC).

Test site Designation No. TW0006 with FCC.

3.7. Table for Supporting Units

For Test Site No: CO01-CB

Support Unit	Brand	Model	FCC ID
Notebook	DELL	E6430	DoC
Flash disk3.0	Transcend	JetFlash-700	DoC
Flash disk3.0	Transcend	JetFlash-700	DoC

For Test Site No: 03CH01-CB

Support Unit	Brand	Model	FCC ID
Notebook	DELL	E4300	DoC

For Test Site No: TH01-CB

Support Unit	Brand	Model	FCC ID
Notebook	DELL	E4300	DoC

3.8. Table for Parameters of Test Software Setting

During testing, Channel and Power Controlling Software provided by the customer was used to control the operating channel as well as the output power level. The RF output power selection is for the setting of RF output power expected by the customer and is going to be fixed on the firmware of the final end product.

Power Parameters of IEEE 802.15.4 ZigBee

Test Software Version	TeraTerm 4.75		
Frequency	2405 MHz	2440 MHz	2475 MHz
IEEE 802.15.4 ZigBee	-4	-4	-4

3.9. EUT Operation during Test

The EUT was programmed to be in continuously transmitting mode.

3.10. Duty Cycle

On Time (ms)	On+Off Time (ms)	Duty Cycle (%)	Duty Factor (dB)	1/T Minimum VBW (kHz)
1.000	1.000	100.00	0.00	0.01

3.11. Test Configurations

3.11.1. AC Power Line Conduction Emissions Test Configuration

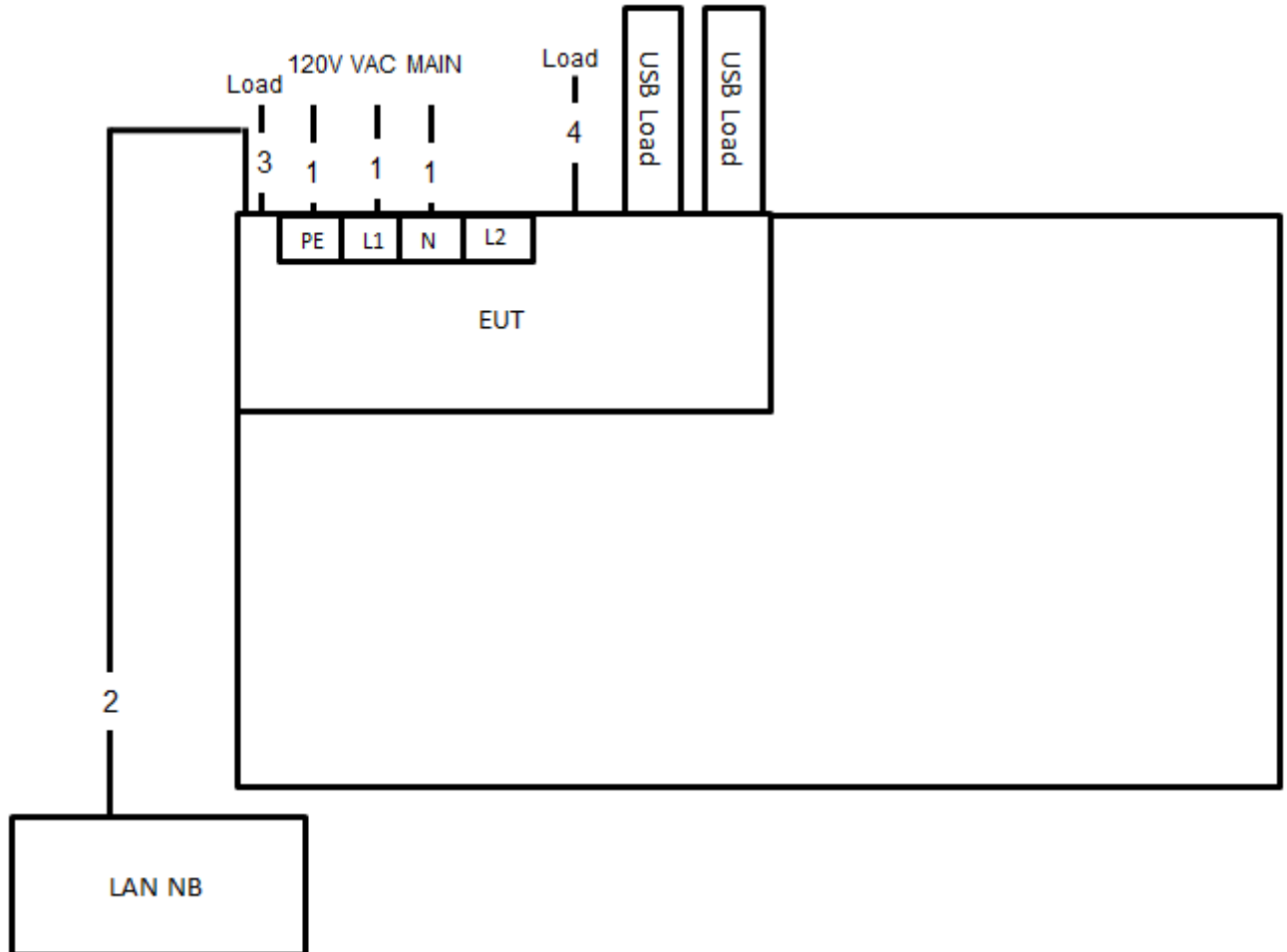

Item	Connection	Shielded	Length
1	Power cable	No	1.8m
2	RJ-45 cable	No	10m
3	RJ-45 cable	No	1.5m
4	RS-485 cable*3	No	3m

3.11.2. Radiation Emissions Test Configuration

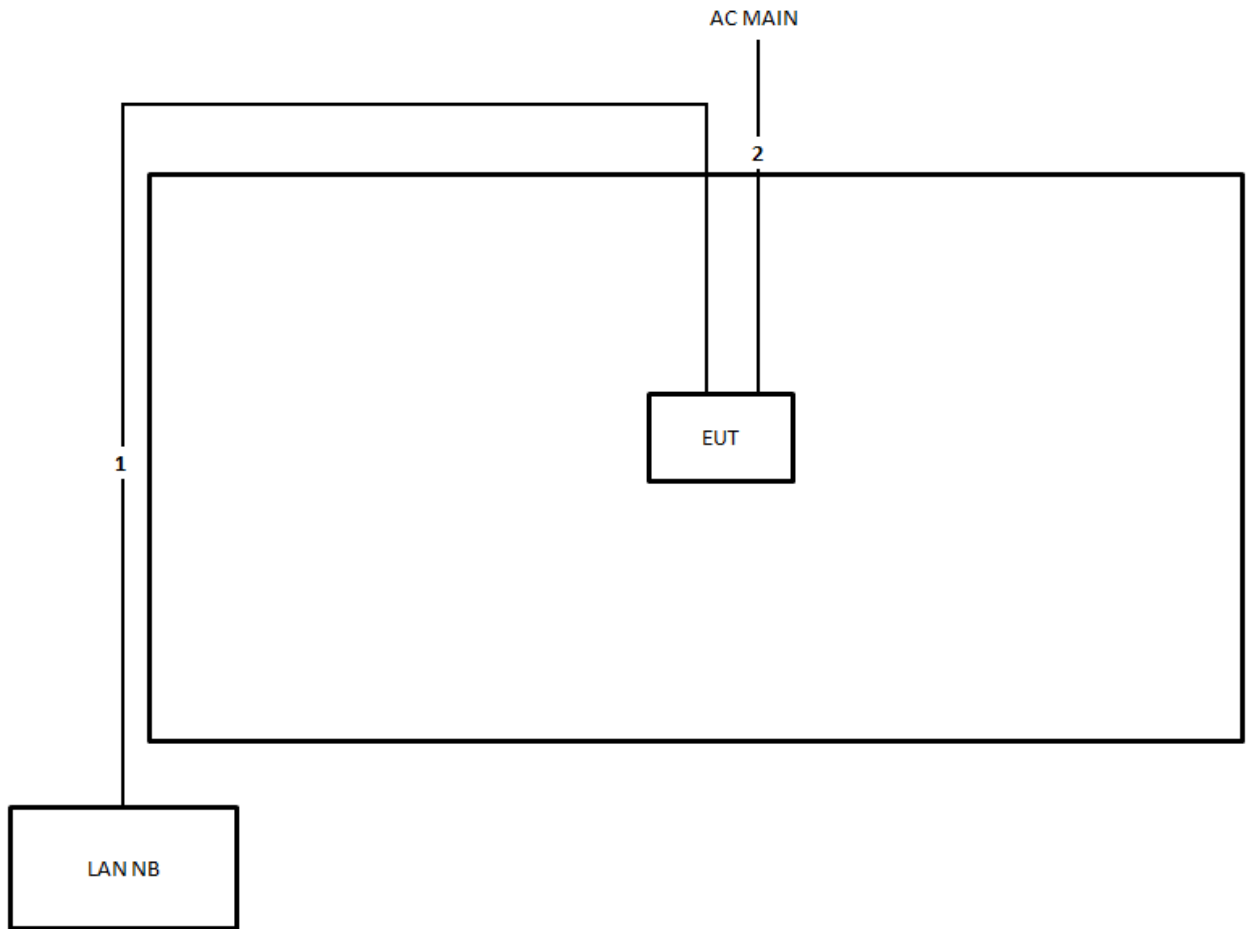

Item	Connection	Shielded	Length
1	RJ-45 cable	No	10m
2	Power cable	No	1.8m

4. TEST RESULT

4.1. AC Power Line Conducted Emissions Measurement

4.1.1. Limit

For a Low-power Radio-frequency Device which is designed to be connected to the AC power line, the radio frequency voltage that is conducted back onto the AC power line on any frequency or frequencies within the band 150 kHz to 30 MHz shall not exceed below limits table.

Frequency (MHz)	QP Limit (dBuV)	AV Limit (dBuV)
0.15~0.5	66~56	56~46
0.5~5	56	46
5~30	60	50

4.1.2. Measuring Instruments and Setting

Please refer to section 5 of equipments list in this report. The following table is the setting of the receiver.

Receiver Parameters	Setting
Attenuation	10 dB
Start Frequency	0.15 MHz
Stop Frequency	30 MHz
IF Bandwidth	9 kHz

4.1.3. Test Procedures

1. Configure the EUT according to ANSI C63.10. The EUT or host of EUT has to be placed 0.4 meter far from the conducting wall of the shielding room and at least 80 centimeters from any other grounded conducting surface.
2. Connect EUT or host of EUT to the power mains through a line impedance stabilization network (LISN).
3. All the support units are connected to the other LISNs. The LISN should provide 50uH/50ohms coupling impedance.
4. The frequency range from 150 kHz to 30 MHz was searched.
5. Set the test-receiver system to Peak Detect Function and Specified Bandwidth with Maximum Hold Mode.
6. The measurement has to be done between each power line and ground at the power terminal.

4.1.4. Test Setup Layout

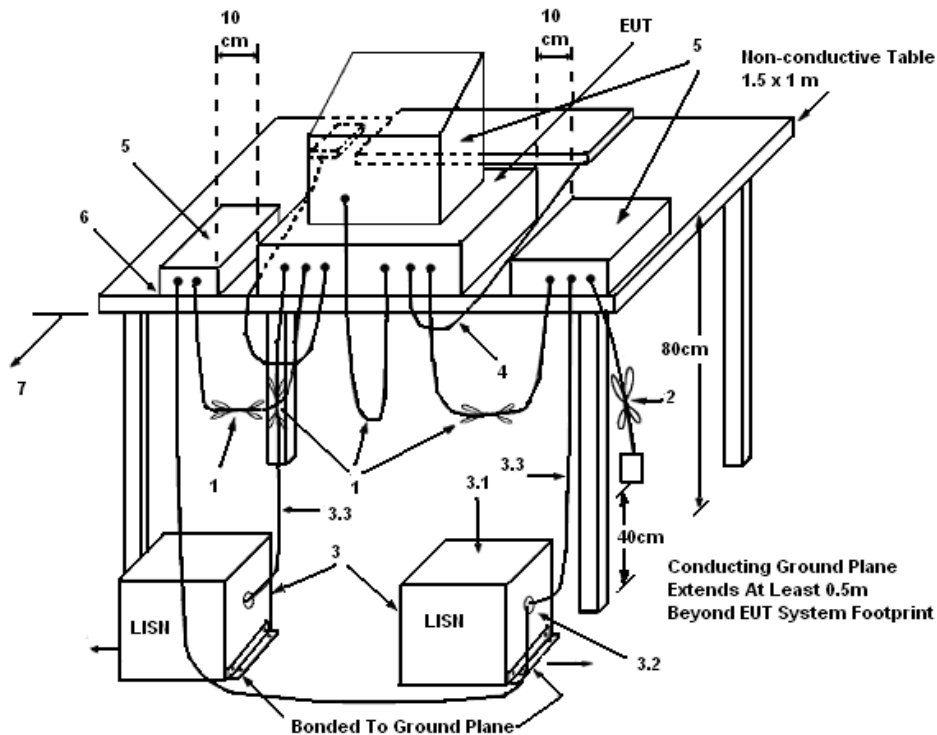

LEGEND:

- (1) Interconnecting cables that hang closer than 40 cm to the ground plane shall be folded back and forth in the center forming a bundle 30 to 40 cm long.
- (2) I/O cables that are not connected to a peripheral shall be bundled in the center. The end of the cable may be terminated, if required, using the correct terminating impedance. The overall length shall not exceed 1 m.
- (3) EUT connected to one LISN. Unused LISN measuring port connectors shall be terminated in 50 Ω . LISN can be placed on top of, or immediately beneath, reference ground plane.
 - (3.1) All other equipment powered from additional LISN(s).
 - (3.2) Multiple outlet strip can be used for multiple power cords of non-EUT equipment.
 - (3.3) LISN at least 80 cm from nearest part of EUT chassis.
- (4) Cables of hand-operated devices, such as keyboards, mice, etc., shall be placed as for normal use.
- (5) Non-EUT components of EUT system being tested.
- (6) Rear of EUT, including peripherals, shall all be aligned and flush with rear of tabletop.
- (7) Rear of tabletop shall be 40 cm removed from a vertical conducting plane that is bonded to the ground plane.

4.1.5. Test Deviation

There is no deviation with the original standard.

4.1.6. EUT Operation during Test

The EUT was placed on the test table and programmed in normal function.

4.1.7. Results of AC Power Line Conducted Emissions Measurement

Temperature	22°C	Humidity	54%
Test Engineer	Max Lin	Phase	Line
Configuration	CTX		

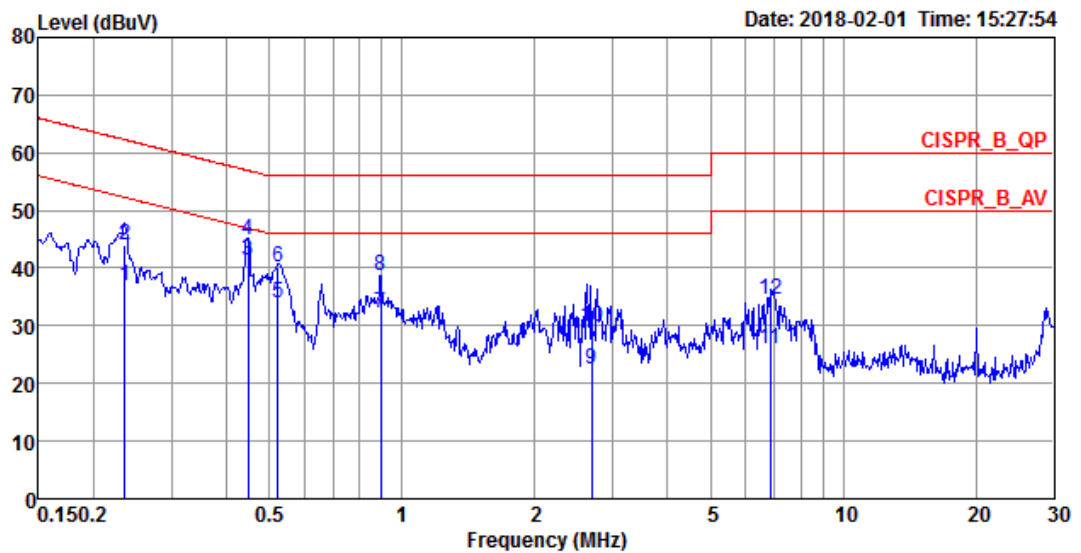

	Freq	Level	Over Limit	Limit Line	Read Level	LISN Factor	Cable Loss	Remark	Pol/Phase
	MHz	dBuV	dB	dBuV	dBuV	dB	dB		
1	0.2353	36.76	-15.50	52.26	26.74	9.92	0.10	Average	LINE
2	0.2353	44.08	-18.18	62.26	34.06	9.92	0.10	QP	LINE
3	0.4468	41.23	-5.70	46.93	31.25	9.95	0.03	Average	LINE
4	0.4468	44.82	-12.11	56.93	34.84	9.95	0.03	QP	LINE
5	0.5238	33.90	-12.10	46.00	23.89	9.95	0.06	Average	LINE
6	0.5238	40.28	-15.72	56.00	30.27	9.95	0.06	QP	LINE
7	0.8944	32.17	-13.83	46.00	22.04	9.96	0.17	Average	LINE
8	0.8944	38.60	-17.40	56.00	28.47	9.96	0.17	QP	LINE
9	2.6883	22.33	-23.67	46.00	12.21	9.96	0.16	Average	LINE
10	2.6883	29.88	-26.12	56.00	19.76	9.96	0.16	QP	LINE
11	6.8412	25.85	-24.15	50.00	15.67	10.05	0.13	Average	LINE
12	6.8412	34.56	-25.44	60.00	24.38	10.05	0.13	QP	LINE

Temperature	22°C	Humidity	54%
Test Engineer	Max Lin	Phase	Neutral
Configuration	CTX		

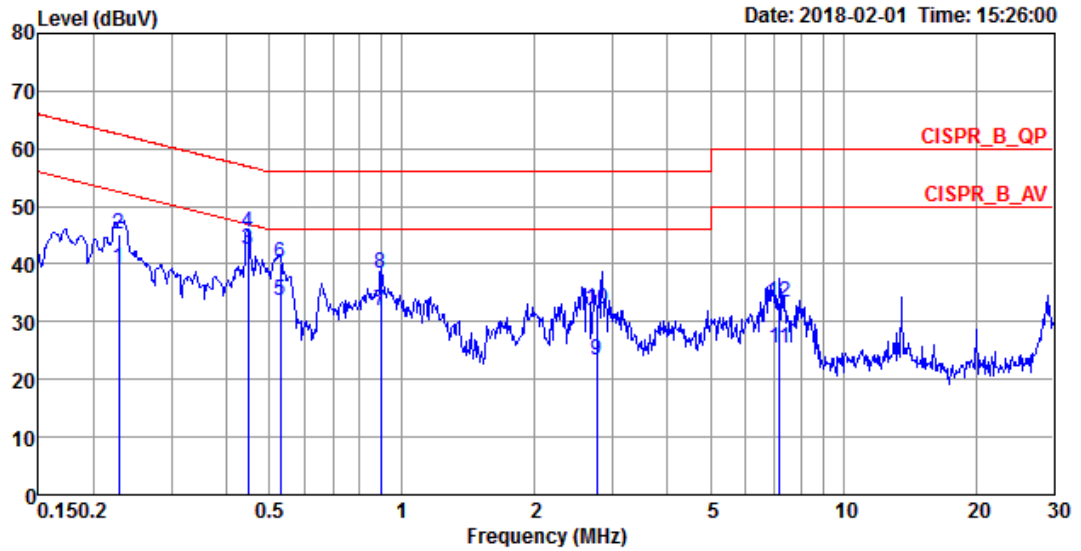

	Freq	Level	Over Limit	Limit Line	Read Level	LISN Factor	Cable Loss	Remark	Pol/Phase
	MHz	dBuV	dB	dBuV	dBuV	dB	dB		
1	0.2280	39.23	-13.29	52.52	29.07	10.05	0.11	Average	NEUTRAL
2	0.2280	45.15	-17.37	62.52	34.99	10.05	0.11	QP	NEUTRAL
3	0.4468	42.39	-4.54	46.93	32.12	10.24	0.03	Average	NEUTRAL
4	0.4468	45.60	-11.33	56.93	35.33	10.24	0.03	QP	NEUTRAL
5	0.5293	33.52	-12.48	46.00	23.24	10.22	0.06	Average	NEUTRAL
6	0.5293	40.28	-15.72	56.00	30.00	10.22	0.06	QP	NEUTRAL
7	0.8944	31.77	-14.23	46.00	21.52	10.08	0.17	Average	NEUTRAL
8	0.8944	38.31	-17.69	56.00	28.06	10.08	0.17	QP	NEUTRAL
9	2.7594	23.23	-22.77	46.00	13.12	9.95	0.16	Average	NEUTRAL
10	2.7594	32.18	-23.82	56.00	22.07	9.95	0.16	QP	NEUTRAL
11	7.1754	25.26	-24.74	50.00	15.04	10.09	0.13	Average	NEUTRAL
12	7.1754	33.28	-26.72	60.00	23.06	10.09	0.13	QP	NEUTRAL

Note:

Level = Read Level + LISN Factor + Cable Loss.

4.2. Maximum Conducted Output Power Measurement

4.2.1. Limit

The limit for output power is 30dBm.

4.2.2. Measuring Instruments and Setting

Please refer to section 5 of equipments list in this report. The following table is the setting of the power meter.

Power Meter Parameter	Setting
Bandwidth	50MHz bandwidth is greater than the EUT emission bandwidth
Detector	Average

4.2.3. Test Procedures

1. Test procedures refer KDB558074 D01 v04 section 9.2.3.2.
2. This procedure provides an alternative for determining the RMS output power using a broadband RF average power meter with a thermocouple detector.

4.2.4. Test Setup Layout

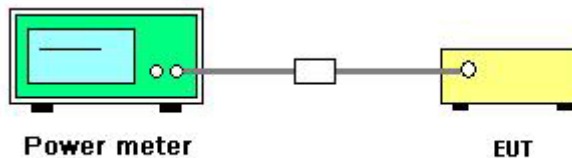

4.2.5. Test Deviation

There is no deviation with the original standard.

4.2.6. EUT Operation during Test

The EUT was programmed to be in continuously transmitting mode.

4.2.7. Test Result of Maximum Conducted Output Power

Temperature	25°C	Humidity	45%
Test Engineer	Roki Liu	Configurations	802.15.4 Zigbee
Test Date	Jul. 29, 2015		

Configuration IEEE 802.15.4 Zigbee / Chain 3

Channel	Frequency	Conducted Power (dBm)	Max. Limit (dBm)	Result
11	2405 MHz	21.29	30.00	Complies
18	2440 MHz	20.34	30.00	Complies
25	2475 MHz	18.70	30.00	Complies

4.3. Power Spectral Density Measurement

4.3.1. Limit

For digitally modulated systems, the power spectral density conducted from the intentional radiator to the antenna shall not be greater than 8 dBm in any 3 kHz band during any time interval of continuous transmission.

4.3.2. Measuring Instruments and Setting

Please refer to section 5 of equipments list in this report. The following table is the setting of Spectrum Analyzer.

Spectrum Parameter	Setting
Attenuation	Auto
Span Frequency	5-30 % greater than the DTS channel bandwidth.
RBW	$3 \text{ kHz} \leq \text{RBW} \leq 100\text{kHz}$
VBW	$\geq 3 \times \text{RBW}$
Detector	Peak
Trace	Max Hold
Sweep Time	Auto couple

4.3.3. Test Procedures

1. Test was performed in accordance with KDB558074 D01 v04 for Performing Compliance Measurements on Digital Transmission Systems (DTS) - section 10.2 Method PKPSD (peak PSD).
2. Use this procedure when the maximum conducted output power in the fundamental emission is used to demonstrate compliance. The EUT must be configured to transmit continuously at full power over the measurement duration.
3. Ensure that the number of measurement points in the sweep $\geq 2 \times \text{span/RBW}$ (use of a greater number of measurement points than this minimum requirement is recommended).
4. Use the peak marker function to determine the maximum level in any 3 kHz band segment within the fundamental EBW.
5. The resulting PSD level must be $\leq 8 \text{ dBm}$.

4.3.4. Test Setup Layout

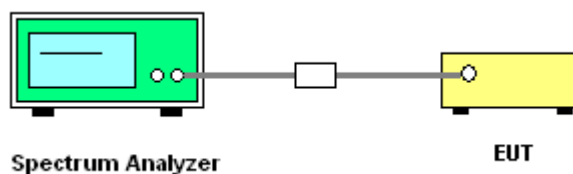

4.3.5. Test Deviation

There is no deviation with the original standard.

4.3.6. EUT Operation during Test

The EUT was programmed to be in continuously transmitting mode.

4.3.7. Test Result of Power Spectral Density

Temperature	25°C	Humidity	45%
Test Engineer	Roki Liu	Configurations	802.15.4 Zigbee

Configuration IEEE 802.15.4 Zigbee / Chain 3

Frequency	Power Density (dBm/3kHz)	Power Density Limit (dBm/3kHz)	Result
2405 MHz	6.34	8.00	Complies
2440 MHz	4.45	8.00	Complies
2475 MHz	2.36	8.00	Complies

Note: All the test values were listed in the report.

For plots, only the channel with worse result was shown.

Power Density Plot on Configuration 802.15.4 Zigbee / 2405 MHz / Chain 3

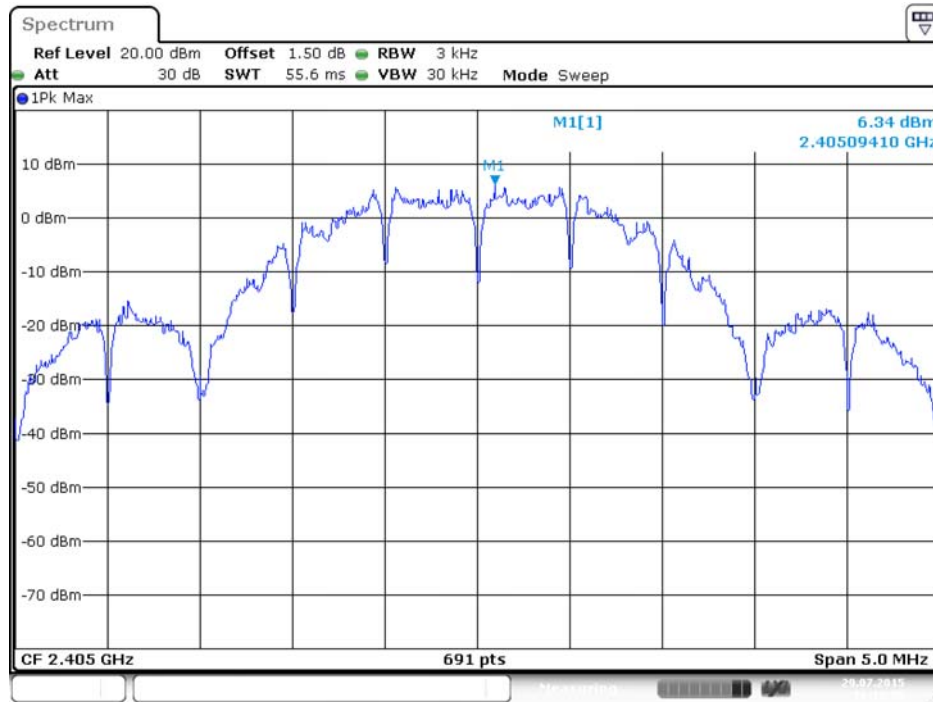

Date: 29. JUL 2015 16:13:55

4.4. 6dB Spectrum Bandwidth Measurement

4.4.1. Limit

For digital modulation systems, the minimum 6dB bandwidth shall be at least 500 kHz.

4.4.2. Measuring Instruments and Setting

Please refer to section 5 of equipments list in this report. The following table is the setting of the spectrum analyzer.

6dB Spectrum Bandwidth	
Spectrum Parameters	Setting
Attenuation	Auto
Span Frequency	> 6dB Bandwidth
RBW	100kHz
VBW	$\geq 3 \times \text{RBW}$
Detector	Peak
Trace	Max Hold
Sweep Time	Auto
99% Occupied Bandwidth	
Spectrum Parameters	Setting
Span	1.5 times to 5.0 times the OBW
RBW	1 % to 5 % of the OBW
VBW	$\geq 3 \times \text{RBW}$
Detector	Peak
Trace	Max Hold

4.4.3. Test Procedures

For Radiated 6dB Bandwidth Measurement:

1. The transmitter was radiated to the spectrum analyzer in peak hold mode.
2. Test was performed in accordance with KDB558074 D01 v04 for Performing Compliance Measurements on Digital Transmission Systems (DTS) - section 8.0 DTS bandwidth = > 8.1 Option 1.
3. Measured the spectrum width with power higher than 6dB below carrier.

4.4.4. Test Setup Layout

For Radiated 6dB Bandwidth Measurement:

This test setup layout is the same as that shown in section 4.5.4.

4.4.5. Test Deviation

There is no deviation with the original standard.

4.4.6. EUT Operation during Test

The EUT was programmed to be in continuously transmitting mode.

4.4.7. Test Result of 6dB Spectrum Bandwidth

Temperature	25°C	Humidity	45%
Test Engineer	Roki Liu	Configurations	802.15.4 Zigbee

Configuration 802.15.4 Zigbee / Chain 3

Channel	Frequency	6dB Bandwidth (MHz)	99% Occupied Bandwidth (MHz)	Min. Limit (kHz)	Test Result
11	2405 MHz	1.59	2.42	500.00	Complies
18	2440 MHz	1.59	2.43	500.00	Complies
25	2475 MHz	1.61	2.43	500.00	Complies

Note: All the test values were listed in the report.

For plots, only the channel with worse result was shown.

6 dB Bandwidth Plot on Configuration 802.15.4 Zigbee / 2405 MHz / Chain 3

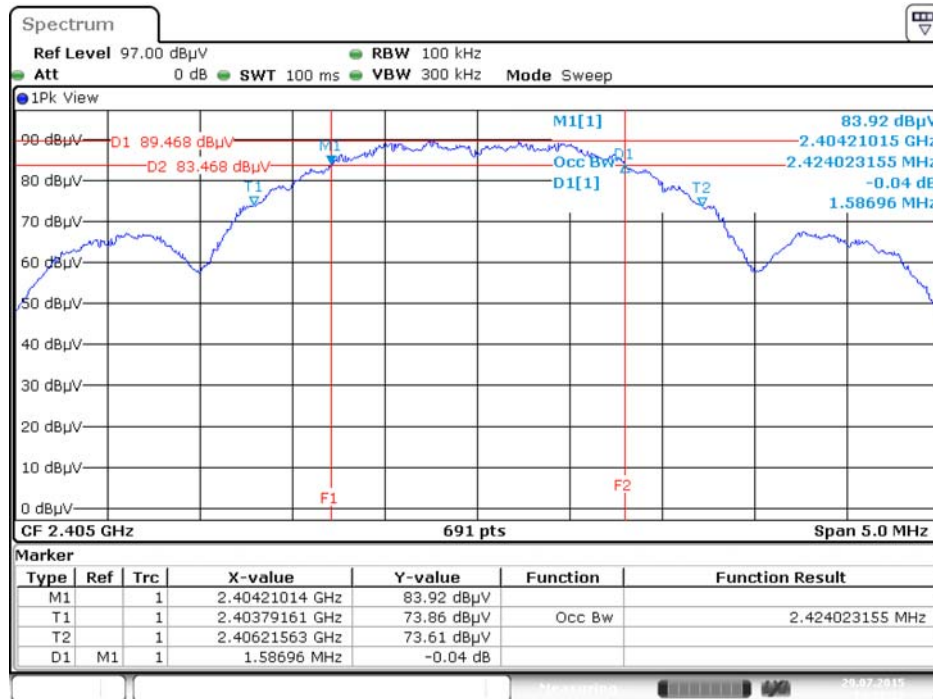

Date: 29.JUL.2015 14:01:17

4.5. Radiated Emissions Measurement

4.5.1. Limit

30dBc in any 100 kHz bandwidth outside the operating frequency band. In case the emission fall within the restricted band specified on 15.205(a), then the 15.209(a) limit in the table below has to be followed.

Frequencies (MHz)	Field Strength (micorvolts/meter)	Measurement Distance (meters)
0.009~0.490	2400/F(kHz)	300
0.490~1.705	24000/F(kHz)	30
1.705~30.0	30	30
30~88	100	3
88~216	150	3
216~960	200	3
Above 960	500	3

4.5.2. Measuring Instruments and Setting

Please refer to section 5 of equipments list in this report. The following table is the setting of spectrum analyzer and receiver.

Spectrum Parameter	Setting
Attenuation	Auto
Start Frequency	1000 MHz
Stop Frequency	10th carrier harmonic
RBW / VBW (Emission in restricted band)	1 MHz / 3MHz for Peak, 1 MHz / 1/T for Average
RBW / VBW (Emission in non-restricted band)	100kHz / 300kHz for peak

Receiver Parameter	Setting
Attenuation	Auto
Start ~ Stop Frequency	9kHz~150kHz / RBW 200Hz for QP
Start ~ Stop Frequency	150kHz~30MHz / RBW 9kHz for QP
Start ~ Stop Frequency	30MHz~1000MHz / RBW 120kHz for QP

4.5.3. Test Procedures

1. Configure the EUT according to ANSI C63.10. The EUT was placed on the top of the turntable 1.5 meter above ground. The phase center of the receiving antenna mounted on the top of a height-variable antenna tower was placed 1m & 3m far away from the turntable.
2. Power on the EUT and all the supporting units. The turntable was rotated by 360 degrees to determine the position of the highest radiation.
3. The height of the broadband receiving antenna was varied between one meter and four meters above ground to find the maximum emissions field strength of both horizontal and vertical polarization.
4. For each suspected emissions, the antenna tower was scan (from 1 M to 4 M) and then the turntable was rotated (from 0 degree to 360 degrees) to find the maximum reading.
5. Set the test-receiver system to Peak or CISPR quasi-peak Detect Function with specified bandwidth under Maximum Hold Mode.
6. For emissions above 1GHz, use 1MHz VBW and 3MHz RBW for peak reading. Then 1MHz RBW and 1/T VBW for average reading in spectrum analyzer.
7. If the emissions level of the EUT in peak mode was 3 dB lower than the average limit specified, then testing will be stopped and peak values of EUT will be reported, otherwise, the emissions which do not have 3 dB margin will be repeated one by one using the quasi-peak method for below 1GHz.
8. For testing above 1GHz, the emissions level of the EUT in peak mode was lower than average limit (that means the emissions level in peak mode also complies with the limit in average mode), then testing will be stopped and peak values of EUT will be reported, otherwise, the emissions will be measured in average mode again and reported.
9. In case the emission is lower than 30MHz, loop antenna has to be used for measurement and the recorded data should be QP measured by receiver. High – Low scan is not required in this case.

4.5.4. Test Setup Layout

For Radiated Emissions: 9kHz ~30MHz

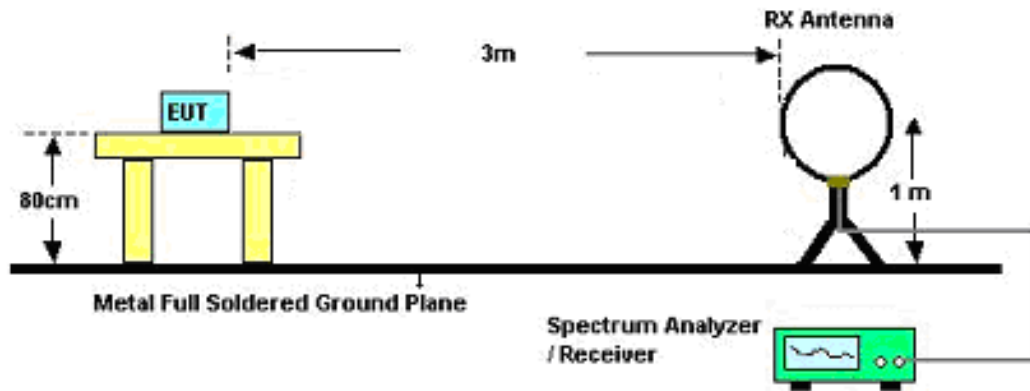

For Radiated Emissions: 30MHz~1GHz

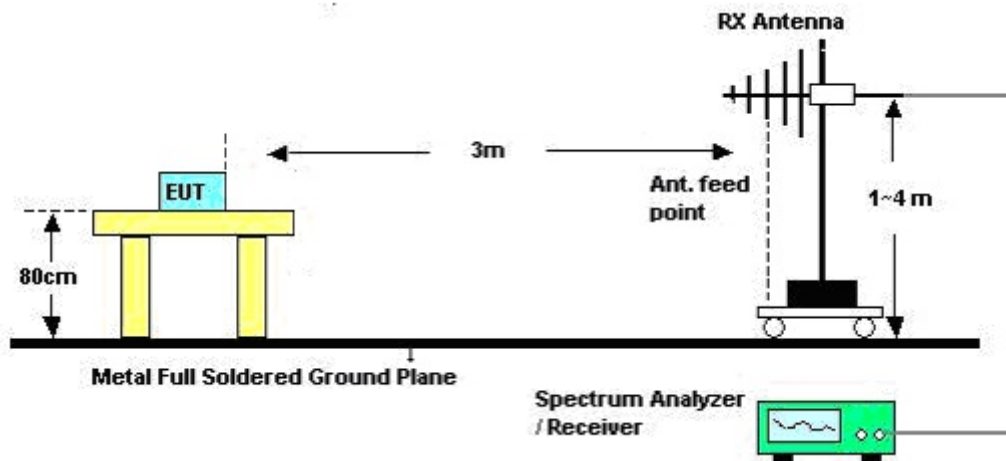

For Radiated Emissions: Above 1GHz

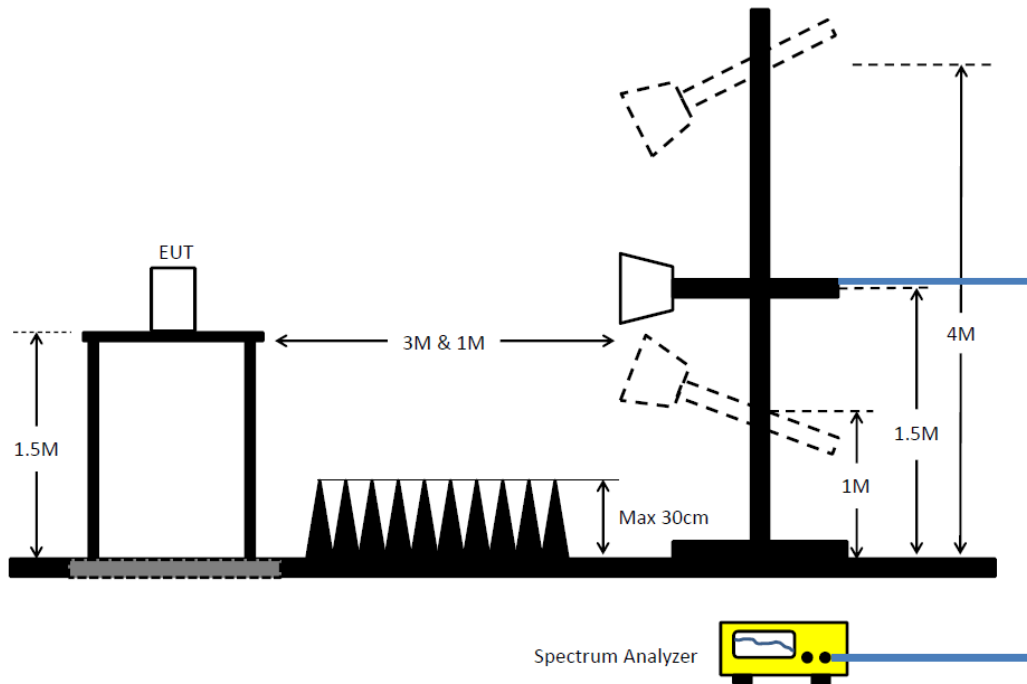

4.5.5. Test Deviation

There is no deviation with the original standard.

4.5.6. EUT Operation during Test

The EUT was programmed to be in continuously transmitting mode.

4.5.7. Results of Radiated Emissions (9kHz~30MHz)

Temperature	21.6°C	Humidity	52%
Test Engineer	Ron Huang	Configurations	CTX
Test Date	Jan. 31, 2018		

Freq. (MHz)	Level (dBuV)	Over Limit (dB)	Limit Line (dBuV)	Remark
-	-	-	-	See Note

Note:

The amplitude of spurious emissions that are attenuated by more than 20 dB below the permissible value has no need to be reported.

Distance extrapolation factor = $40 \log(\text{specific distance} / \text{test distance})$ (dB);

Limit line = specific limits (dBuV) + distance extrapolation factor.

4.5.8. Results of Radiated Emissions (30MHz~1GHz)

Temperature	21.6°C	Humidity	52%
Test Engineer	Ron Huang	Configurations	CTX

Horizontal

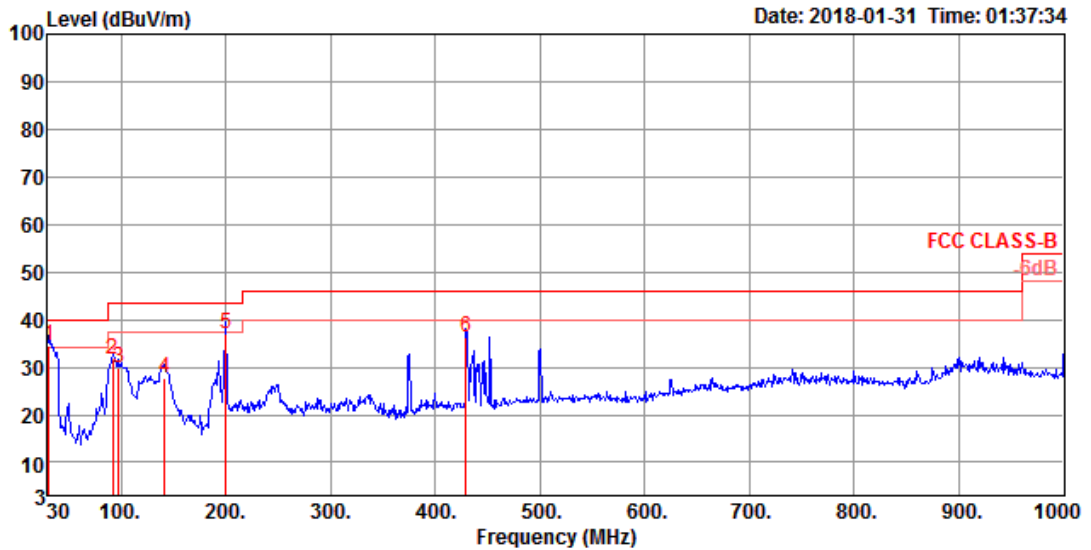

	Freq	Level	Limit	Over	Read	Cable	Antenna	Preamp	A/Pos	T/Pos	Remark	Pol/Phase
	MHz	dBuV/m	dBuV/m	dB	dBuV	dB	dB/m	dB	cm	deg		
1	30.97	34.47	40.00	-5.53	40.91	0.98	25.01	32.43	150	108	QP	HORIZONTAL
2	92.08	31.70	43.50	-11.80	47.63	0.81	15.64	32.38	200	62	QP	HORIZONTAL
3	97.90	29.69	43.50	-13.81	44.51	0.84	16.72	32.38	200	62	QP	HORIZONTAL
4	141.55	27.52	43.50	-15.98	41.12	1.16	17.58	32.34	200	277	QP	HORIZONTAL
5	199.75	36.83	43.50	-6.67	50.89	1.95	16.30	32.31	125	166	QP	HORIZONTAL
6	429.64	36.13	46.00	-9.87	42.84	2.83	22.76	32.30	150	357	QP	HORIZONTAL

Vertical

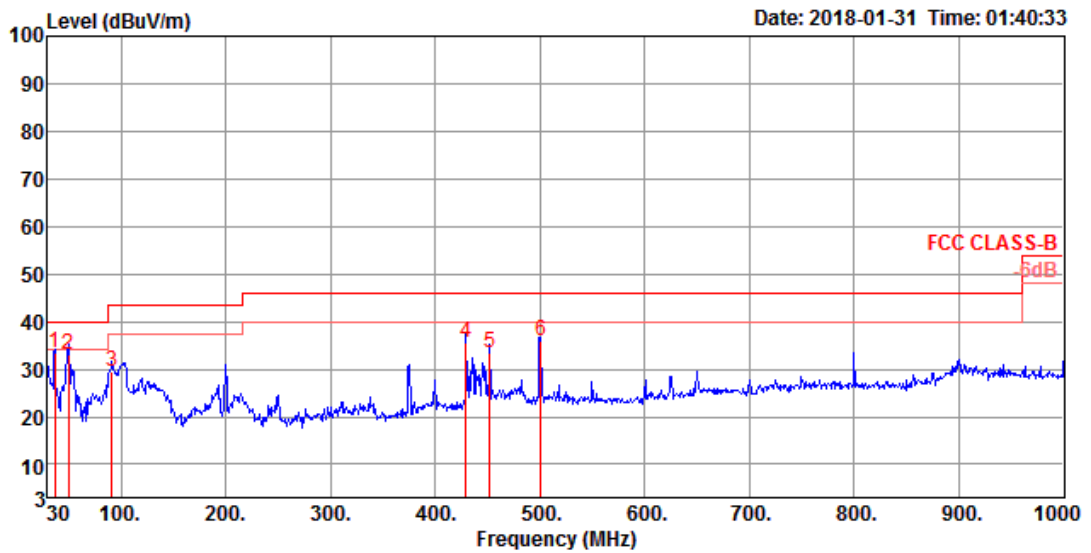

	Freq	Level	Limit	Over	Read	CableAntenna	Preamp	A/Pos	T/Pos	Remark	Pol/Phase
	MHz	dBuV/m	dBuV/m	dB	dBuV	dB	dB/m	dB	cm	deg	
1	36.79	33.29	40.00	-6.71	43.02	1.07	21.63	32.43	100	280 QP	VERTICAL
2	49.40	33.13	40.00	-6.87	49.03	1.43	15.09	32.42	100	360 QP	VERTICAL
3	91.11	29.54	43.50	-13.96	45.69	0.79	15.45	32.39	100	239 QP	VERTICAL
4	429.64	35.61	46.00	-10.39	42.32	2.83	22.76	32.30	150	359 QP	VERTICAL
5	451.95	33.33	46.00	-12.67	39.85	2.74	23.05	32.31	100	161 QP	VERTICAL
6	500.45	35.82	46.00	-10.18	41.39	2.94	23.82	32.33	100	245 QP	VERTICAL

Note:

The amplitude of spurious emissions that are attenuated by more than 20dB below the permissible value has no need to be reported.

Emission level (dBuV/m) = 20 log Emission level (uV/m).

Corrected Reading: Antenna Factor + Cable Loss + Read Level - Preamp Factor = Level.

4.5.9. Results for Radiated Emissions (1GHz~10th Harmonic)

Temperature	24°C	Humidity	55%
Test Engineer	JC Yang	Configurations	802.15.4 Zigbee CH 11
Test Date	Jul. 10, 2015	Test Chain	Chain 3

Horizontal

	Freq	Level	Limit	Over	Read	Cable	Antenna	Preamp	T/Pos	A/Pos	Remark	Pol/Phase
	MHz	dBuV/m	dBuV/m	dB	dBuV	dB	dB/m	dB	deg	cm		
1	4810.89	41.99	54.00	-12.01	39.77	4.09	32.66	34.53	246	145	Average	HORIZONTAL
2	4811.06	51.41	74.00	-22.59	49.19	4.09	32.66	34.53	246	145	Peak	HORIZONTAL

Vertical

	Freq	Level	Limit	Over	Read	Cable	Antenna	Preamp	T/Pos	A/Pos	Remark	Pol/Phase
	MHz	dBuV/m	dBuV/m	dB	dBuV	dB	dB/m	dB	deg	cm		
1	4811.00	41.09	54.00	-12.91	38.87	4.09	32.66	34.53	4	154	Average	VERTICAL
2	4811.07	50.89	74.00	-23.11	48.67	4.09	32.66	34.53	4	154	Peak	VERTICAL

Temperature	24°C	Humidity	55%
Test Engineer	JC Yang	Configurations	802.15.4 Zigbee CH 18
Test Date	Jul. 10, 2015	Test Chain	Chain 3

Horizontal

	Freq	Level	Limit Line	Over Limit	Read Level	CableAntenna Loss	Antenna Factor	Preamp Factor	T/Pos	A/Pos	Remark	Pol/Phase
	MHz	dBuV/m	dBuV/m	dB	dBuV	dB	dB/m	dB	deg	cm		
1	4878.98	52.75	74.00	-21.25	50.35	4.13	32.78	34.51	308	150	Peak	HORIZONTAL
2	4878.98	43.76	54.00	-10.24	41.36	4.13	32.78	34.51	308	150	Average	HORIZONTAL
3	7318.60	64.40	74.00	-9.60	56.80	5.10	37.26	34.76	71	164	Peak	HORIZONTAL
4	7318.66	53.99	54.00	-0.01	46.39	5.10	37.26	34.76	71	164	Average	HORIZONTAL

Vertical

	Freq	Level	Limit Line	Over Limit	Read Level	CableAntenna Loss	Antenna Factor	Preamp Factor	T/Pos	A/Pos	Remark	Pol/Phase
	MHz	dBuV/m	dBuV/m	dB	dBuV	dB	dB/m	dB	deg	cm		
1	4880.89	51.86	74.00	-22.14	49.46	4.13	32.78	34.51	8	151	Peak	VERTICAL
2	4880.98	42.84	54.00	-11.16	40.44	4.13	32.78	34.51	8	151	Average	VERTICAL
3	7318.56	62.08	74.00	-11.92	54.48	5.10	37.26	34.76	182	167	Peak	VERTICAL
4	7318.64	51.98	54.00	-2.02	44.38	5.10	37.26	34.76	182	167	Average	VERTICAL

Temperature	24°C	Humidity	55%
Test Engineer	JC Yang	Configurations	802.15.4 Zigbee CH 25
Test Date	Jul. 10, 2015	Test Chain	Chain 3

Horizontal

	Freq	Level	Limit Line	Over Limit	Read Level	Cable Loss	Antenna Factor	Preamp Factor	T/Pos	A/Pos	Remark	Pol/Phase
	MHz	dBuV/m	dBuV/m	dB	dBuV	dB	dB/m	dB	deg	cm		
1	4948.94	52.45	74.00	-21.55	49.87	4.16	32.91	34.49	309	160	Peak	HORIZONTAL
2	4948.97	43.25	54.00	-10.75	40.67	4.16	32.91	34.49	309	160	Average	HORIZONTAL
3	7423.48	58.61	74.00	-15.39	50.87	5.12	37.40	34.78	228	188	Peak	HORIZONTAL
4	7426.72	48.32	54.00	-5.68	40.58	5.12	37.40	34.78	228	188	Average	HORIZONTAL

Vertical

	Freq	Level	Limit Line	Over Limit	Read Level	Cable Loss	Antenna Factor	Preamp Factor	T/Pos	A/Pos	Remark	Pol/Phase
	MHz	dBuV/m	dBuV/m	dB	dBuV	dB	dB/m	dB	deg	cm		
1	4948.94	51.93	74.00	-22.07	49.35	4.16	32.91	34.49	169	195	Peak	VERTICAL
2	4949.08	43.09	54.00	-10.91	40.51	4.16	32.91	34.49	169	195	Average	VERTICAL
3	7423.44	45.50	54.00	-8.50	37.76	5.12	37.40	34.78	125	229	Average	VERTICAL
4	7423.50	56.03	74.00	-17.97	48.29	5.12	37.40	34.78	125	229	Peak	VERTICAL

Note:

The amplitude of spurious emissions that are attenuated by more than 20dB below the permissible value has no need to be reported.

Emission level (dBuV/m) = 20 log Emission level (uV/m).

Corrected Reading: Antenna Factor + Cable Loss + Read Level - Preamp Factor = Level.

4.6. Emissions Measurement

4.6.1. Limit

30dBc in any 100 kHz bandwidth outside the operating frequency band. In case the emission fall within the restricted band specified on 15.205(a), then the 15.209(a) limit in the table below has to be followed.

Frequencies (MHz)	Field Strength (micorvolts/meter)	Measurement Distance (meters)
0.009~0.490	2400/F(kHz)	300
0.490~1.705	24000/F(kHz)	30
1.705~30.0	30	30
30~88	100	3
88~216	150	3
216~960	200	3
Above 960	500	3

4.6.2. Measuring Instruments and Setting

Please refer to section 5 of equipments list in this report. The following table is the setting of the spectrum analyzer.

Spectrum Parameter	Setting
Attenuation	Auto
Span Frequency	100 MHz
RBW / VBW (Emission in restricted band)	1MHz / 3MHz for Peak, 1MHz / 1/T for Average
RBW / VBW (30dBc in any 100 kHz bandwidth emission)	100 kHz / 300 kHz for Peak

4.6.3. Test Procedures

For Radiated band edges Measurement:

1. The test procedure is the same as section 4.5.3.

For Radiated Out of Band Emission Measurement:

1. Test was performed in accordance with KDB558074 D01 v04 for Performing Compliance Measurements on Digital Transmission Systems (DTS) Operating Under §15.247 section 10.1 Unwanted Emissions into Non-Restricted Frequency Bands Measurement Procedure.

4.6.4. Test Setup Layout

For Radiated band edges Measurement:

This test setup layout is the same as that shown in section 4.5.4.

For Radiated Out of Band Emission Measurement:

This test setup layout is the same as that shown in section 4.5.4.

4.6.5. Test Deviation

There is no deviation with the original standard.

4.6.6. EUT Operation during Test

The EUT was programmed to be in continuously transmitting mode.

4.6.7. Test Result of Band Edge and Fundamental Emissions

Temperature	24°C	Humidity	55%
Test Engineer	JC Yang	Configurations	802.15.4 Zigbee CH 11, 18, 25
Test Date	Jul. 09, 2015	Test Chain	Chain 3

Channel 11

	Freq	Level	Limit	Over	Read	CableAntenna	Preamp	T/Pos	A/Pos	Remark	Pol/Phase
	MHz	dBuV/m	dBuV/m	dB	dBuV	dB	dB/m	deg	cm		
1	2390.00	61.12	74.00	-12.88	30.12	2.86	28.14	0.00	254	205 Peak	HORIZONTAL
2	2390.00	51.59	54.00	-2.41	20.59	2.86	28.14	0.00	254	205 Average	HORIZONTAL
3	2404.60	118.45			87.46	2.87	28.12	0.00	254	205 Peak	HORIZONTAL
4	2405.00	114.09			83.10	2.87	28.12	0.00	254	205 Average	HORIZONTAL

Item 3, 4 are the fundamental frequency at 2405 MHz.

Channel 18

	Freq	Level	Limit	Over	Read	CableAntenna	Preamp	T/Pos	A/Pos	Remark	Pol/Phase
	MHz	dBuV/m	dBuV/m	dB	dBuV	dB	dB/m	deg	cm		
1	2376.80	55.38	74.00	-18.62	24.36	2.85	28.17	0.00	29	286 Peak	VERTICAL
2	2390.00	43.66	54.00	-10.34	12.66	2.86	28.14	0.00	29	286 Average	VERTICAL
3	2439.60	109.26			78.30	2.89	28.07	0.00	29	286 Peak	VERTICAL
4	2440.00	105.13			74.17	2.89	28.07	0.00	29	286 Average	VERTICAL
5	2483.50	43.54	54.00	-10.46	12.61	2.91	28.02	0.00	29	286 Average	VERTICAL
6	2485.20	54.99	74.00	-19.01	24.06	2.91	28.02	0.00	29	286 Peak	VERTICAL

Item 3, 4 are the fundamental frequency at 2440 MHz.

Channel 25

	Freq	Level	Limit	Over	Read	CableAntenna	Preamp	T/Pos	A/Pos	Remark	Pol/Phase
	MHz	dBuV/m	dBuV/m	dB	dBuV	dB	dB/m	deg	cm		
1	2475.00	109.17			78.24	2.91	28.02	0.00	250	257 Average	HORIZONTAL
2	2475.60	113.76			82.83	2.91	28.02	0.00	250	257 Peak	HORIZONTAL
3	2483.50	64.58	74.00	-9.42	33.65	2.91	28.02	0.00	250	257 Peak	HORIZONTAL
4	2484.00	53.91	54.00	-0.09	22.98	2.91	28.02	0.00	250	257 Average	HORIZONTAL

Item 1, 2 are the fundamental frequency at 2475 MHz.

For Emission not in Restricted Band

Plot on Configuration 802.15.4 Zigbee / Reference Level / Chain 3

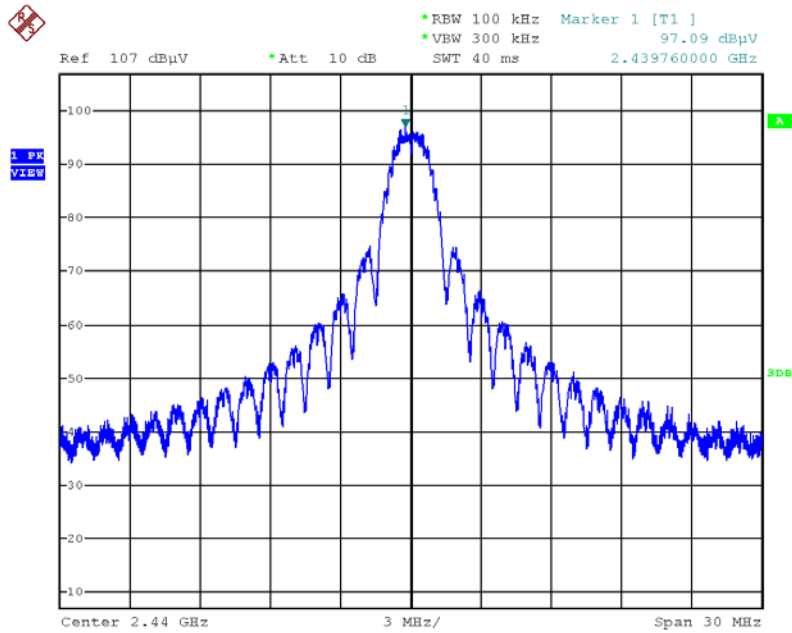

Date: 10.JUL.2015 02:57:20

Plot on Configuration 802.15.4 Zigbee / CH 11 / 30MHz~2400MHz (down 30dBc) / Chain 3

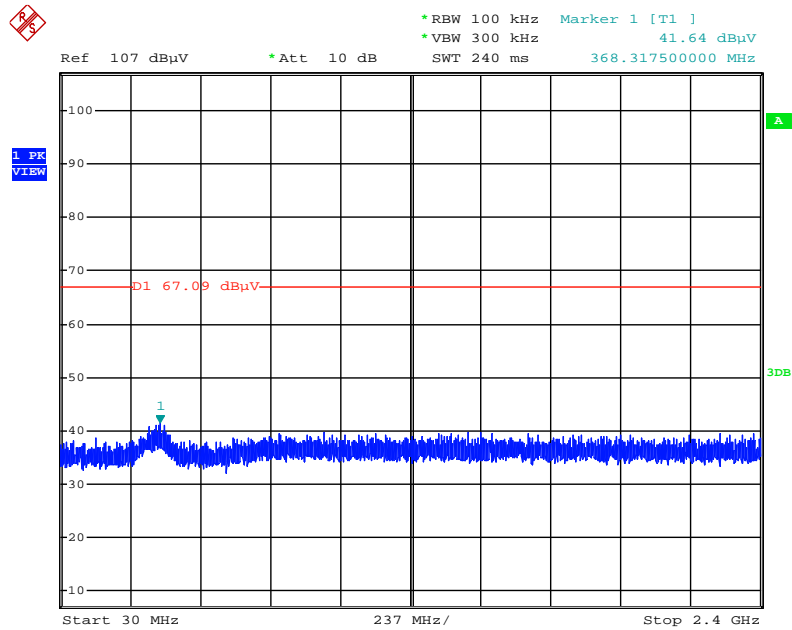

Date: 4.AUG.2015 21:55:20

Plot on Configuration 802.15.4 Zigbee / CH 11 / 2500MHz~26500MHz (down 30dBc) / Chain 3

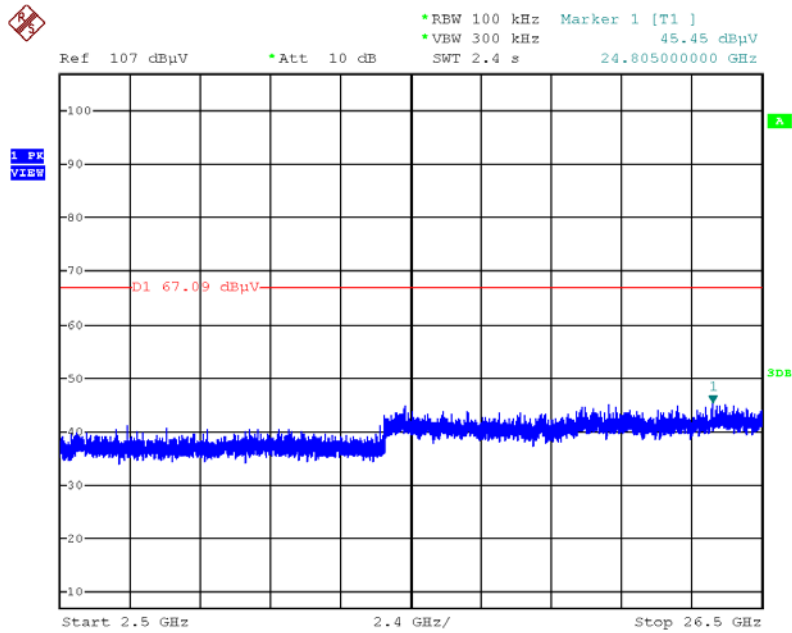

Date: 10.JUL.2015 02:58:45

Plot on Configuration 802.15.4 Zigbee / CH 25 / 30MHz~2400MHz (down 30dBc) / Chain 3

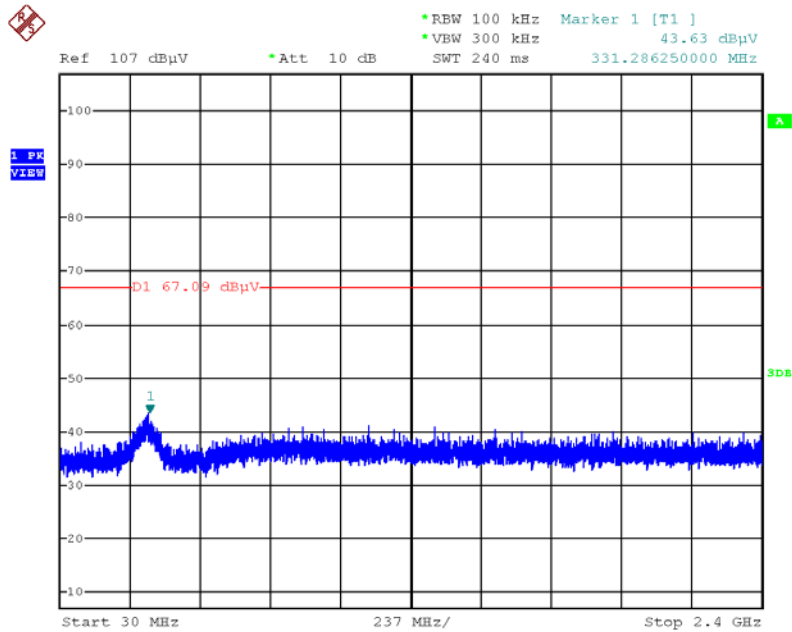

Date: 10.JUL.2015 02:59:19

Plot on Configuration 802.15.4 Zigbee / CH 25 / 2500MHz~26500MHz (down 30dBc) / Chain 3

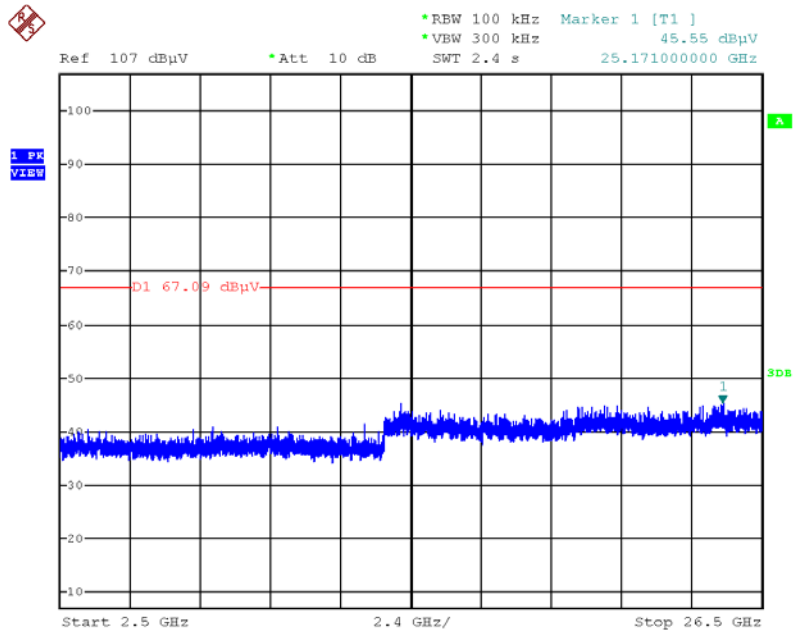

Date: 10.JUL.2015 02:59:43

4.7. Antenna Requirements

4.7.1. Limit

Except for special regulations, the Low-power Radio-frequency Devices must not be equipped with any jacket for installing an antenna with extension cable. An intentional radiator shall be designed to ensure that no antenna other than that furnished by the responsible party shall be used with the device. The use of a permanently attached antenna or of an antenna that uses a unique coupling to the intentional radiator shall be considered sufficient to comply with the provisions of this Section. The manufacturer may design the unit so that the user can replace a broken antenna, but the use of a standard antenna jack or electrical connector is prohibited. Further, this requirement does not apply to intentional radiators that must be professionally installed.

4.7.2. Antenna Connector Construction

Please refer to section 3.3 in this test report; antenna connector complied with the requirements.

5. LIST OF MEASURING EQUIPMENTS

Instrument	Manufacturer	Model No.	Serial No.	Characteristics	Calibration Date	Calibration Due Date	Remark
EMI Receiver	Agilent	N9038A	MY52260140	9kHz ~ 8.4GHz	Jan. 17, 2018	Jan. 16, 2019	Conduction (CO01-CB)
LISN	F.C.C.	FCC-LISN-50-16-2	04083	150kHz ~ 100MHz	Dec. 20, 2017	Dec. 19, 2018	Conduction (CO01-CB)
LISN	Schwarzbeck	NSLK 8127	8127647	9kHz ~ 30MHz	Dec. 29, 2017	Dec. 28, 2018	Conduction (CO01-CB)
COND Cable	Woken	Cable	01	150kHz ~ 30MHz	May 23, 2017	May 22, 2018	Conduction (CO01-CB)
Software	Audix	E3	6.120210n	-	N.C.R.	N.C.R.	Conduction (CO01-CB)
BILOG ANTENNA with 6dB Attenuator	TESEQ & EMCI	CBL6112D & N-6-06	37880 & AT-N0609	20MHz ~ 2GHz	Aug. 30, 2017	Aug. 29, 2018	Radiation (03CH01-CB)
Loop Antenna	Teseq	HLA 6120	24155	9kHz - 30 MHz	Mar. 16, 2016*	Mar. 15, 2018*	Radiation (03CH01-CB)
Horn Antenna	EMCO	3115	00075790	750MHz ~ 18GHz	Oct. 28, 2014	Oct. 27, 2015	Radiation (03CH01-CB)
Horn Antenna	Schwarzbeck	BBHA 9170	BBHA9170252	15GHz ~ 40GHz	Aug. 22, 2014	Aug. 21, 2015	Radiation (03CH01-CB)
Pre-Amplifier	EMCI	EMC330N	980332	20MHz ~ 3GHz	May 02, 2017	May 01, 2018	Radiation (03CH01-CB)
Pre-Amplifier	Agilent	8449B	3008A02310	1GHz ~ 26.5GHz	Jan. 12, 2015	Jan. 11, 2016	Radiation (03CH01-CB)
Pre-Amplifier	WM	TF-130N-R1	923365	26GHz ~ 40GHz	Nov. 25, 2014	Nov. 24, 2015	Radiation (03CH01-CB)
Spectrum Analyzer	R&S	FSP40	100056	9kHz ~ 40GHz	Nov. 06, 2014	Nov. 05, 2015	Radiation (03CH01-CB)
Spectrum Analyzer	R&S	FSP40	100056	9kHz ~ 40GHz	Nov. 23, 2017	Nov. 22, 2018	Radiation (03CH01-CB)
EMI Test	R&S	ESCS	100355	9kHz ~ 2.75GHz	May 06, 2017	May 05, 2018	Radiation (03CH01-CB)
RF Cable-low	Woken	Low Cable-16+17	N/A	30 MHz ~ 1 GHz	Oct. 11, 2017	Oct. 10, 2018	Radiation (03CH01-CB)
RF Cable-high	Woken	High Cable-40G-1	N/A	1 GHz ~ 40 GHz	Nov. 15, 2014	Nov. 14, 2015	Radiation (03CH01-CB)
RF Cable-high	Woken	High Cable-40G-2	N/A	1 GHz ~ 40 GHz	Nov. 15, 2014	Nov. 14, 2015	Radiation (03CH01-CB)
Spectrum analyzer	R&S	FSV40	100979	9kHz~40GHz	Dec. 12, 2014	Dec. 11, 2015	Conducted (TH01-CB)
Temp. and Humidity Chamber	Ten Billion	TTH-D3SP	TBN-931011	-30~100 degree	Jun. 02, 2015	Jun. 01, 2016	Conducted (TH01-CB)
RF Cable-high	Woken	RG402	High Cable-7	1 GHz – 26.5 GHz	Nov. 15, 2014	Nov. 14, 2015	Conducted (TH01-CB)
RF Cable-high	Woken	RG402	High Cable-8	1 GHz – 26.5 GHz	Nov. 15, 2014	Nov. 14, 2015	Conducted (TH01-CB)
RF Cable-high	Woken	RG402	High Cable-9	1 GHz – 26.5 GHz	Nov. 15, 2014	Nov. 14, 2015	Conducted (TH01-CB)
RF Cable-high	Woken	RG402	High Cable-10	1 GHz – 26.5 GHz	Nov. 15, 2014	Nov. 14, 2015	Conducted (TH01-CB)
RF Cable-high	Woken	RG402	High Cable-6	1 GHz – 26.5 GHz	Nov. 15, 2014	Nov. 14, 2015	Conducted (TH01-CB)



Power Sensor	Agilent	U2021XA	MY53410001	50MHz~18GHz	Nov. 03, 2014	Nov. 02, 2015	Conducted (TH01-CB)
--------------	---------	---------	------------	-------------	---------------	---------------	------------------------

Note: Calibration Interval of instruments listed above is one year.

*Calibration Interval of instruments listed above is two year.

N.C.R. means Non-Calibration required.

6. MEASUREMENT UNCERTAINTY

Test Items	Uncertainty	Remark
Conducted Emission (150kHz ~ 30MHz)	3.2 dB	Confidence levels of 95%
Radiated Emission (30MHz ~ 1,000MHz)	3.6 dB	Confidence levels of 95%
Radiated Emission (1GHz ~ 18GHz)	3.7 dB	Confidence levels of 95%
Radiated Emission (18GHz ~ 40GHz)	3.5 dB	Confidence levels of 95%
Conducted Emission	1.7 dB	Confidence levels of 95%