



# SPORTON International Inc.

No. 52, Hwa Ya 1st Rd., Hwa Ya Technology Park, Kwei-Shan Hsiang, Tao Yuan Hsien, Taiwan, R.O.C.  
Ph: 886-3-327-3456 / FAX: 886-3-327-0973 / www.sporton.com.tw

## FCC RADIO TEST REPORT

Applicant's company	SunPower Corporation
Applicant Address	1414 Harbour Way South, Richmond, CA 94804, USA
FCC ID	YAW513402
Manufacturer's company (1)	ZyXEL Communications Corp.
Manufacturer Address (1)	No.6, Chuangxin 2nd Rd., Baoshan Township, Hsinchu County 308, Taiwan (R.O.C.)
Manufacturer's company (2)	MitraStar Technology Corporation
Manufacturer Address (2)	No. 6, Innovation Rd II, Hsinchu Science Park, Hsinchu 30076, Taiwan
Manufacturer's company (3)	WuXI MitraStar Technology Co. Ltd
Manufacturer Address (3)	60#-E, Minshan Road, Wuxi New district Jangsu, P.R.C.

Product Name	SunPower Monitoring System with PVS5x
Brand Name	SUNPOWER
Model No.	PVS5x
Test Rule	47 CFR FCC Part 15 Subpart C § 15.247
Test Freq. Range	2400 ~ 2483.5MHz
Received Date	Jun. 26, 2015
Final Test Date	Aug. 04, 2015
Submission Type	Original Equipment

### Statement

**Test result included in this report is for the IEEE 802.11n and IEEE 802.11b/g of the product.**

The test result in this report refers exclusively to the presented test model / sample.

Without written approval of SPORTON International Inc., the test report shall not be reproduced except in full.

The measurements and test results shown in this test report were made in accordance with the procedures and found in compliance with the limit given in **ANSI C63.10-2013, 47 CFR FCC Part 15 Subpart C, KDB558074 D01 v03r03 and KDB 662911 D01 v02r01.**

The test equipment used to perform the test is calibrated and traceable to NML/ROC.



## Table of Contents

<b>1. VERIFICATION OF COMPLIANCE</b> .....	<b>1</b>
<b>2. SUMMARY OF THE TEST RESULT</b> .....	<b>2</b>
<b>3. GENERAL INFORMATION</b> .....	<b>3</b>
3.1. Product Details.....	3
3.2. Accessories.....	4
3.3. Table for Filed Antenna.....	5
3.4. Table for Carrier Frequencies .....	7
3.5. Table for Test Modes.....	8
3.6. Table for Testing Locations.....	9
3.7. Table for Supporting Units .....	9
3.8. Table for Parameters of Test Software Setting .....	10
3.9. EUT Operation during Test .....	10
3.10. Duty Cycle.....	10
3.11. Test Configurations .....	11
<b>4. TEST RESULT</b> .....	<b>13</b>
4.1. AC Power Line Conducted Emissions Measurement.....	13
4.2. Maximum Conducted Output Power Measurement.....	17
4.3. Power Spectral Density Measurement .....	19
4.4. 6dB Spectrum Bandwidth Measurement .....	27
4.5. Radiated Emissions Measurement .....	34
4.6. Emissions Measurement .....	53
4.7. Antenna Requirements .....	71
<b>5. LIST OF MEASURING EQUIPMENTS</b> .....	<b>72</b>
<b>6. MEASUREMENT UNCERTAINTY</b> .....	<b>73</b>
<b>APPENDIX A. TEST PHOTOS</b> .....	<b>A1 ~ A5</b>
<b>APPENDIX B. MAXIMUM PERMISSIBLE EXPOSURE</b> .....	<b>B1 ~ B5</b>



## History of This Test Report

REPORT NO.	VERSION	DESCRIPTION	ISSUED DATE
FR562534AA	Rev. 01	Initial issue of report	Aug. 24, 2015

## 1. VERIFICATION OF COMPLIANCE

Product Name : SunPower Monitoring System with PVS5x  
Brand Name : SUNPOWER  
Model No. : PVS5x  
Applicant : SunPower Corporation  
Test Rule Part(s) : 47 CFR FCC Part 15 Subpart C § 15.247

Sporton International as requested by the applicant to evaluate the EMC performance of the product sample received on Jun. 26, 2015 would like to declare that the tested sample has been evaluated and found to be in compliance with the tested rule parts. The data recorded as well as the test configuration specified is true and accurate for showing the sample's EMC nature.



Sam Chen

SPORTON INTERNATIONAL INC.

## 2. SUMMARY OF THE TEST RESULT

Applied Standard: 47 CFR FCC Part 15 Subpart C				
Part	Rule Section	Description of Test	Result	Under Limit
4.1	15.207	AC Power Line Conducted Emissions	Complies	16.19 dB
4.2	15.247(b)(3)	Maximum Conducted Output Power	Complies	2.04 dB
4.3	15.247(e)	Power Spectral Density	Complies	3.87 dB
4.4	15.247(a)(2)	6dB Spectrum Bandwidth	Complies	-
4.5	15.247(d)	Radiated Emissions	Complies	0.20 dB
4.6	15.247(d)	Band Edge Emissions	Complies	0.04 dB
4.7	15.203	Antenna Requirements	Complies	-

### 3. GENERAL INFORMATION

#### 3.1. Product Details

Items	Description
Product Type	IEEE 802.11b: WLAN (1TX, 1RX) IEEE 802.11g: WLAN (2TX, 2RX) IEEE 802.11n: WLAN (2TX, 2RX)
Radio Type	Intentional Transceiver
Power Type	Internal power supply
Modulation	IEEE 802.11b: DSSS IEEE 802.11g: OFDM IEEE 802.11n: see the below table
Data Modulation	IEEE 802.11b: DSSS (BPSK / QPSK / CCK) IEEE 802.11g/n: OFDM (BPSK / QPSK / 16QAM / 64QAM)
Data Rate (Mbps)	IEEE 802.11b: DSSS (1/ 2/ 5.5/11) IEEE 802.11g: OFDM (6/9/12/18/24/36/48/54) IEEE 802.11n: see the below table
Frequency Range	2400 ~ 2483.5MHz
Channel Number	11 for 20MHz bandwidth ; 7 for 40MHz bandwidth
Channel Band Width (99%)	IEEE 802.11b: 13.98 MHz IEEE 802.11g: 27.96 MHz IEEE 802.11n MCS0 (HT20): 27.18 MHz IEEE 802.11n MCS0 (HT40): 39.22 MHz
Maximum Conducted Output Power	IEEE 802.11b: 21.63 dBm IEEE 802.11g: 27.96 dBm IEEE 802.11n MCS0 (HT20): 27.63 dBm IEEE 802.11n MCS0 (HT40): 20.17 dBm
Carrier Frequencies	Please refer to section 3.4
Antenna	Please refer to section 3.3

Items	Description
Beamforming Function	<input type="checkbox"/> With beamforming <input checked="" type="checkbox"/> Without beamforming

**Antenna and Band width**

Antenna	Single (TX)		Two (TX)	
	20 MHz	40 MHz	20 MHz	40 MHz
Band width Mode				
IEEE 802.11b	V	X	X	X
IEEE 802.11g	X	X	V	X
IEEE 802.11n	X	X	V	V

**IEEE 11n Spec.**

Protocol	Number of Transmit Chains (NTX)	Data Rate / MCS
802.11n (HT20)	2	MCS 0-15
802.11n (HT40)	2	MCS 0-15

Note 1: IEEE Std. 802.11n modulation consists of HT20 and HT40 (HT: High Throughput).  
Then EUT supports HT20 and HT40.

Note 2: Modulation modes consist of below configuration: HT20/HT40: IEEE 802.11n

**3.2. Accessories**

Others
RJ-45 cable*1, Non-shielded, w/o ferrite core, 1m
RS-485 cable*1(2 wire), Non-shielded, w/o ferrite core, 3m
RS-485 cable*1(4 wire), Non-shielded, w/o ferrite core, 3m
Cradle*1

### 3.3. Table for Filed Antenna

Ant.	Brand	P/N	Antenna Type	Connector	Gain (dBi)
1	Airgain	N2420GS2-T-PK1-B90U	PIFA Antenna	I-PEX	Note 1
2	Airgain	N2420GS2-T-PK1-G155U	PIFA Antenna	I-PEX	Note 1
3	Airgain	N2420GS2-T-PK1-B130U	PIFA Antenna	I-PEX	Note 2
4	Airgain	N2420GS2-T-PK1-G70U	PIFA Antenna	I-PEX	Note 2

Note 1:

Ant.	Gain (dBi)			
	2412 MHz	2437 MHz	2442 MHz	2462 MHz
1	4.1	4.2	3.7	4.1
2	3.2	2.8	3.0	2.8

Note 2:

Ant.	Gain (dBi)		
	2405 MHz	2440 MHz	2475 MHz
3	2.3	1.8	1.4
4	4.8	4.7	4.2

Note 3:

**For IEEE 802.11b mode (1TX/1RX):**

The EUT supports the antenna with TX and RX diversity functions.

Both Chain 1 and Chain 2 support transmit and receive functions, but only one of them will be used at one time.

The Chain 2 generated the worst case, so it was selected to test and record in the report.

**For IEEE 802.11g/n mode (2TX/2RX):**

Chain 1 and Chain 2 will transmit/receive the same signal simultaneously.

Chain 1 and Chain 2 can be used as transmitting/receiving antennas.

**For Zigbee mode (1TX/1RX):**

Only Chain 3 can be used as transmitting/receiving antenna.

Only Chain 4 can be used as transmitting/receiving antenna.



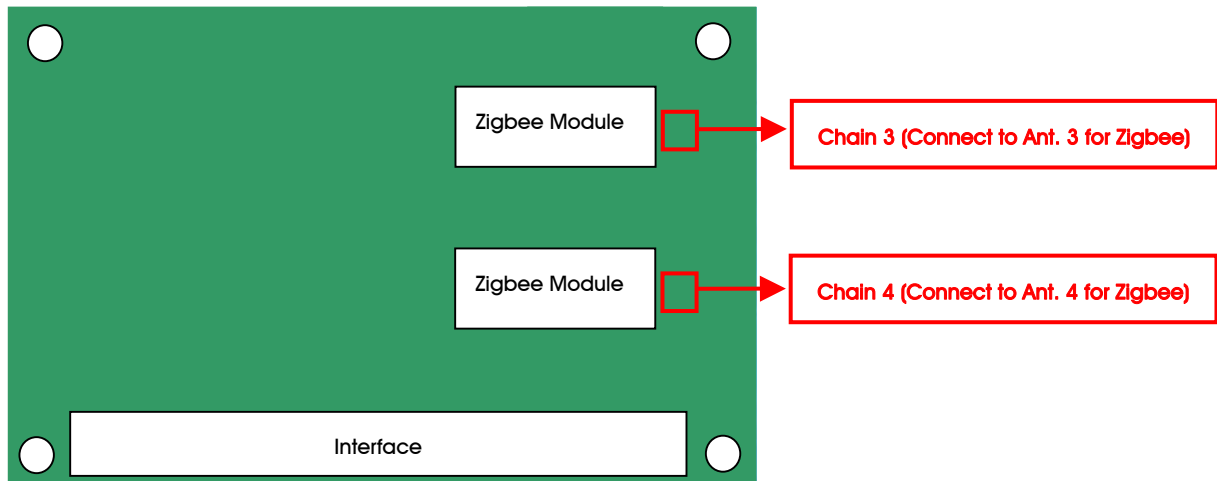
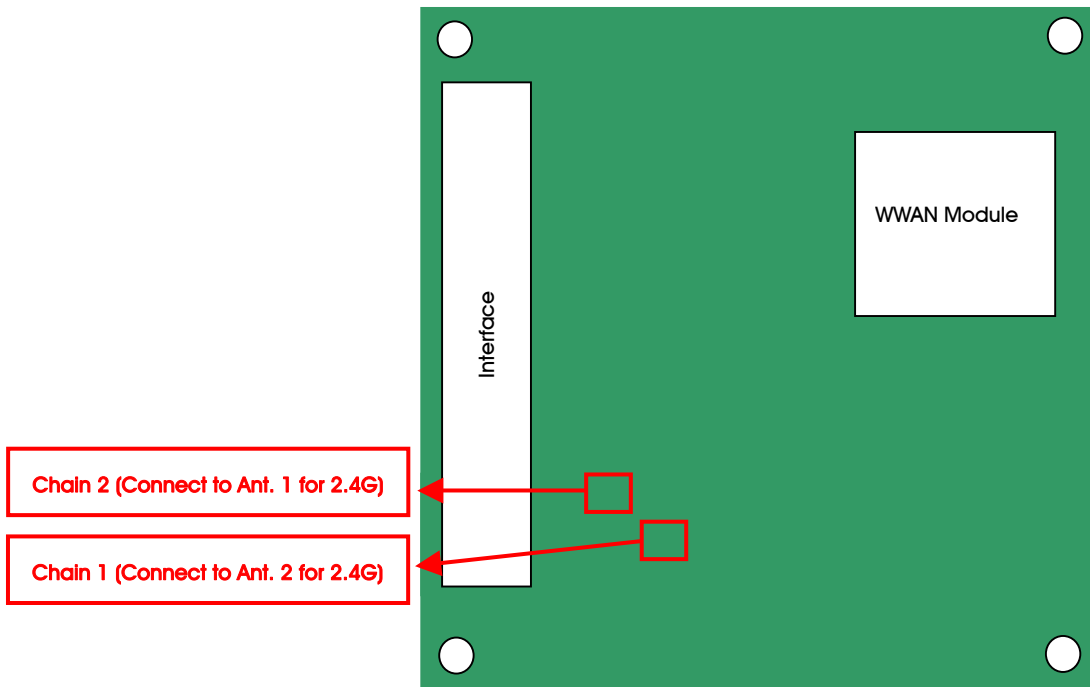

### 3.4. Table for Carrier Frequencies

There are two bandwidth systems.

For 20MHz bandwidth systems, use Channel 1~Channel 11.

For 40MHz bandwidth systems, use Channel 3~Channel 9.

Frequency Band	Channel No.	Frequency	Channel No.	Frequency
2400~2483.5MHz	1	2412 MHz	7	2442 MHz
	2	2417 MHz	8	2447 MHz
	3	2422 MHz	9	2452 MHz
	4	2427 MHz	10	2457 MHz
	5	2432 MHz	11	2462 MHz
	6	2437 MHz	-	-

### 3.5. Table for Test Modes

Preliminary tests were performed in different data rate to find the worst radiated emission. The data rate shown in the table below is the worst-case rate with respect to the specific test item. Investigation has been done on all the possible configurations for searching the worst cases. The following table is a list of the test modes shown in this test report.

Test Items	Mode	Data Rate	Channel	Chain
AC Power Line Conducted Emissions	CTX	-	-	-
Maximum Conducted Output Power	11b/CCK	1 Mbps	1/6/11	2
	11g/BPSK	6 Mbps	1/6/11	1+2
	11n HT20	MCS0	1/6/11	1+2
	11n HT40	MCS0	3/6/9	1+2
Power Spectral Density	11b/CCK	1 Mbps	1/6/11	2
	11g/BPSK	6 Mbps	1/6/11	1+2
	11n HT20	MCS0	1/6/11	1+2
	11n HT40	MCS0	3/6/9	1+2
6dB Spectrum Bandwidth	11b/CCK	1 Mbps	1/6/11	2
	11g/BPSK	6 Mbps	1/6/11	1+2
	11n HT20	MCS0	1/6/11	1+2
	11n HT40	MCS0	3/6/9	1+2
Radiated Emissions 9kHz~1GHz	CTX	-	-	-
Radiated Emissions 1GHz~10 <sup>th</sup> Harmonic	11b/CCK	1 Mbps	1/6/11	2
	11g/BPSK	6 Mbps	1/6/11	1+2
	11n HT20	MCS0	1/6/11	1+2
	11n HT40	MCS0	3/6/9	1+2
Band Edge Emissions	11b/CCK	1 Mbps	1/6/11	2
	11g/BPSK	6 Mbps	1/6/11	1+2
	11n HT20	MCS0	1/6/11	1+2
	11n HT40	MCS0	3/6/9	1+2

The EUT can only be used at Y axis.

The following test modes were performed for all tests:

**For Conducted Emission test:**

Mode 1. CTX-EUT (WiFi + Zigbee: Chain 3 + Zigbee: Chain 4)

**For Radiated Emission below 1GHz test:**

Mode 1. CTX-EUT (WiFi + Zigbee: Chain 3 + Zigbee; Chain 4)

**For Radiated Emission above 1GHz test:**

Mode 1. CTX-EUT

**For Co-location MPE Test:**

Mode 1. WLAN + Zigbee (chain 3) + Zigbee (chain 4)+ WWAN (FCC ID: R17HE910)

Mode 2. WLAN + Zigbee (chain 3) + Zigbee (chain 4)+ WWAN (FCC ID: XMR201312UC20)

**3.6. Table for Testing Locations**

Test Site Location				
Address:	No.8, Lane 724, Bo-ai St., Jhubei City, Hsinchu County 302, Taiwan, R.O.C.			
TEL:	886-3-656-9065			
FAX:	886-3-656-9085			
Test Site No.	Site Category	Location	FCC Reg. No.	IC File No.
03CH01-CB	SAC	Hsin Chu	262045	IC 4086D
CO01-CB	Conduction	Hsin Chu	262045	IC 4086D
TH01-CB	OVEN Room	Hsin Chu	-	-

Open Area Test Site (OATS); Semi Anechoic Chamber (SAC).

**3.7. Table for Supporting Units**
**For Test Site No: 03CH01-CB**

Support Unit	Brand	Model	FCC ID
Notebook	DELL	E4300	DoC
3G SIM Card	N/A	N/A	N/A
3G base station	R&S	CMU200	N/A

**For Test Site No: CO01-CB**

Support Unit	Brand	Model	FCC ID
Notebook	DELL	E6430	DoC
3G SIM Card	N/A	N/A	N/A
3G base station	R&S	CMU200	N/A

**For Test Site No: TH01-CB**

Support Unit	Brand	Model	FCC ID
Notebook	DELL	E4300	DoC

### 3.8. Table for Parameters of Test Software Setting

During testing, Channel and Power Controlling Software provided by the customer was used to control the operating channel as well as the output power level. The RF output power selection is for the setting of RF output power expected by the customer and is going to be fixed on the firmware of the final end product.

Test Software Version	Art2-GUI Version 2.3					
Mode	Test Frequency (MHz)					
	NCB: 20MHz			NCB: 40MHz		
	2412 MHz	2437 MHz	2462 MHz	2422 MHz	2437 MHz	2452 MHz
802.11b	21.5	22	21.5	-	-	-
802.11g	17.5	27	19	-	-	-
802.11n MCS0 HT20	16.5	26.5	18.5	-	-	-
802.11n MCS0 HT40	-	-	-	13	17	13.5

### 3.9. EUT Operation during Test

The EUT was programmed to be in continuously transmitting mode.

### 3.10. Duty Cycle

Mode	On Time (ms)	On+Off Time (ms)	Duty Cycle (%)	Duty Factor (dB)	1/T Minimum VBW (kHz)
802.11b	1.000	1.000	100.00	0.00	0.01
802.11g	1.350	1.396	96.73	0.14	0.74
802.11n MCS0 HT20	1.263	1.310	96.41	0.16	0.79
802.11n MCS0 HT40	0.630	0.667	94.52	0.24	1.59

### 3.11. Test Configurations

#### 3.11.1. AC Power Line Conduction Emissions Test Configuration

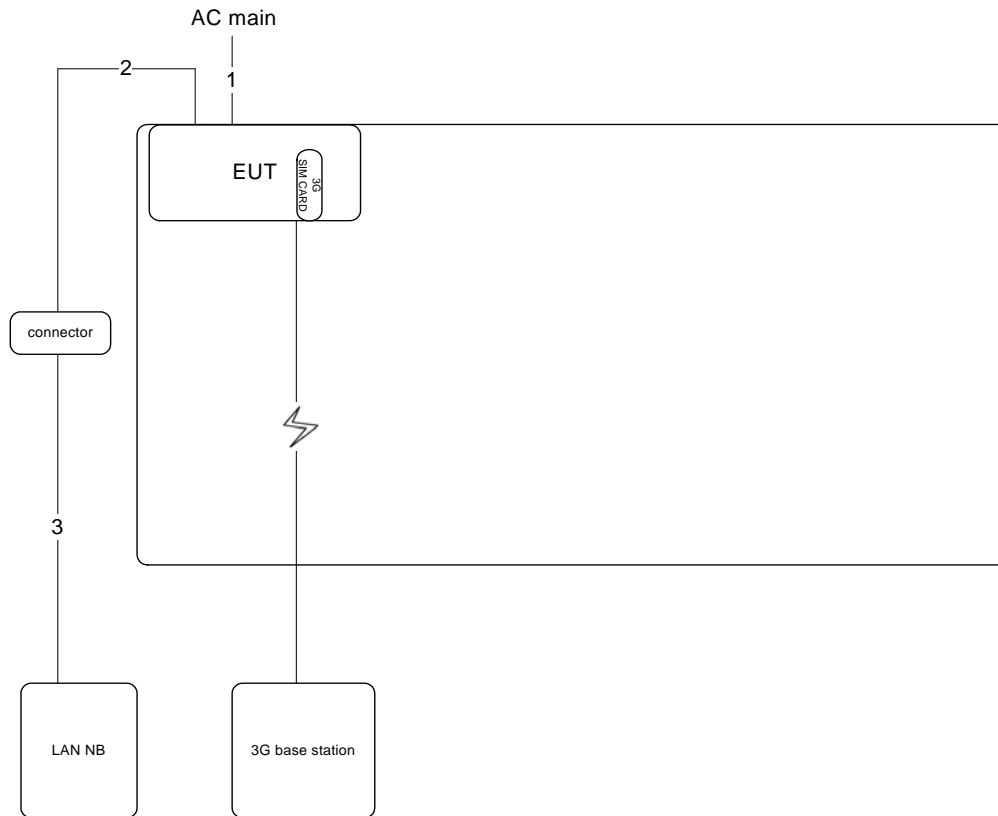

Item	Connection	Shielded	Length
1	Power cable	No	1.8m
2	RJ-45 cable	No	1m
3	RJ-45 cable	No	10m

### 3.11.2. Radiation Emissions Test Configuration

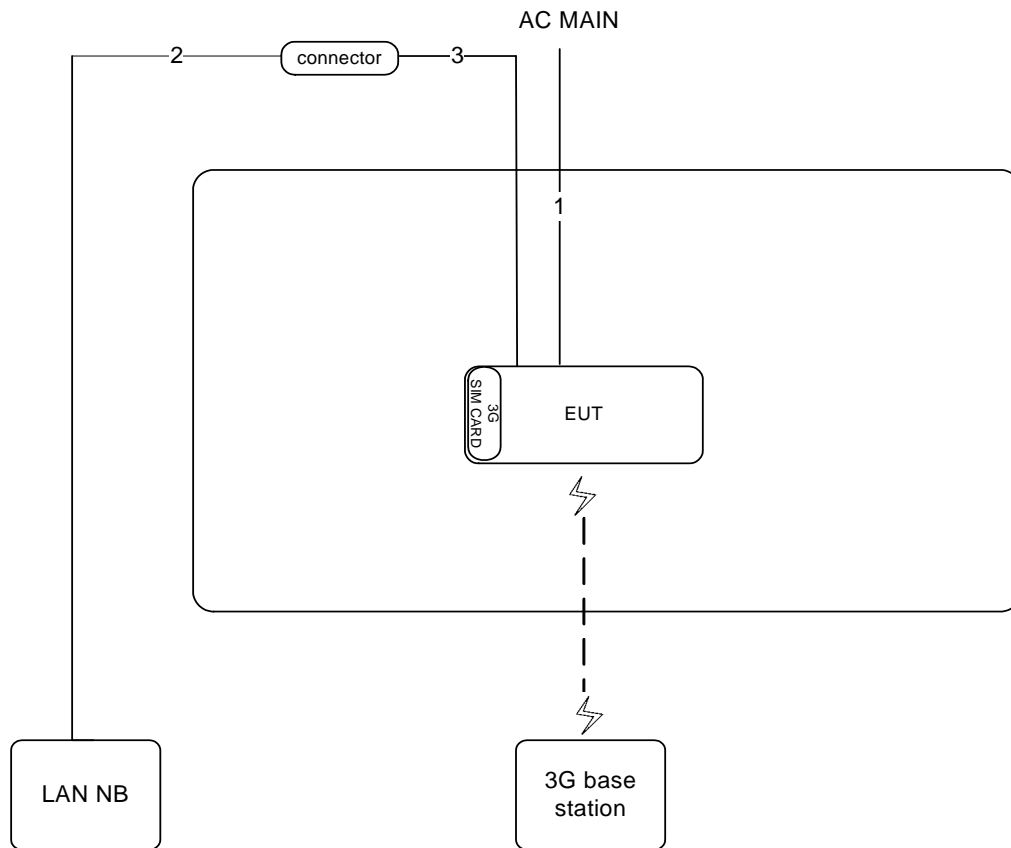

Item	Connection	Shielded	Length
1	Power cable	No	1.8m
2	RJ-45 cable	No	10m
3	RJ-45 cable	No	1m

## 4. TEST RESULT

### 4.1. AC Power Line Conducted Emissions Measurement

#### 4.1.1. Limit

For this product which is designed to be connected to the AC power line, the radio frequency voltage that is conducted back onto the AC power line on any frequency or frequencies within the band 150 kHz to 30 MHz shall not exceed below limits table.

Frequency (MHz)	QP Limit (dBuV)	AV Limit (dBuV)
0.15~0.5	66~56	56~46
0.5~5	56	46
5~30	60	50

#### 4.1.2. Measuring Instruments and Setting

Please refer to section 5 of equipments list in this report. The following table is the setting of the receiver.

Receiver Parameters	Setting
Attenuation	10 dB
Start Frequency	0.15 MHz
Stop Frequency	30 MHz
IF Bandwidth	9 kHz

#### 4.1.3. Test Procedures

1. Configure the EUT according to ANSI C63.10. The EUT or host of EUT has to be placed 0.4 meter far from the conducting wall of the shielding room and at least 80 centimeters from any other grounded conducting surface.
2. Connect EUT or host of EUT to the power mains through a line impedance stabilization network (LISN).
3. All the support units are connected to the other LISNs. The LISN should provide 50uH/50ohms coupling impedance.
4. The frequency range from 150 kHz to 30 MHz was searched.
5. Set the test-receiver system to Peak Detect Function and Specified Bandwidth with Maximum Hold Mode.
6. The measurement has to be done between each power line and ground at the power terminal.



#### 4.1.4. Test Setup Layout

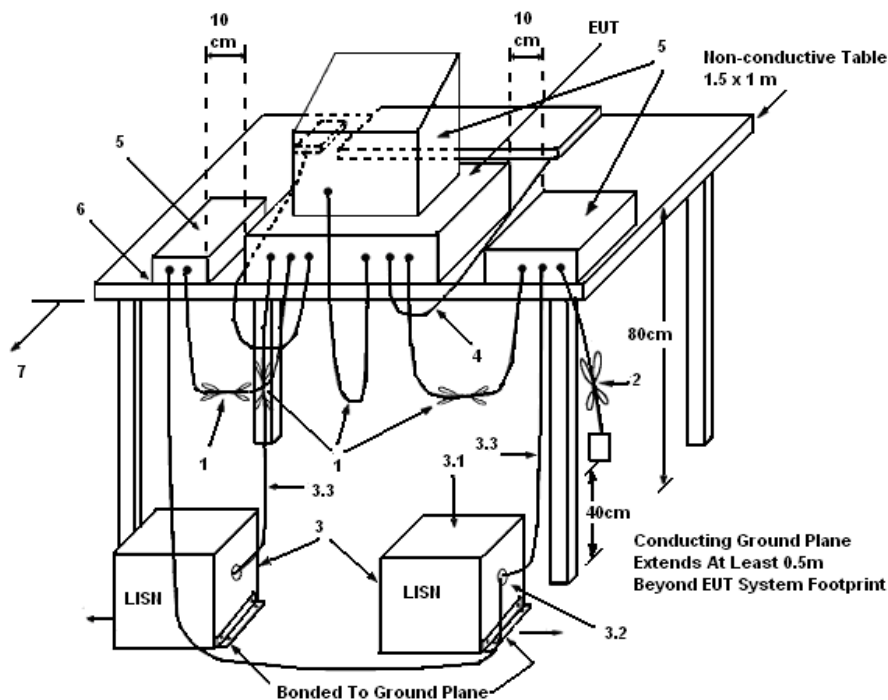

#### LEGEND:

- (1) Interconnecting cables that hang closer than 40 cm to the ground plane shall be folded back and forth in the center forming a bundle 30 to 40 cm long.
- (2) I/O cables that are not connected to a peripheral shall be bundled in the center. The end of the cable may be terminated, if required, using the correct terminating impedance. The overall length shall not exceed 1 m.
- (3) EUT connected to one LISN. Unused LISN measuring port connectors shall be terminated in  $50 \Omega$ . LISN can be placed on top of, or immediately beneath, reference ground plane.
  - (3.1) All other equipment powered from additional LISN(s).
  - (3.2) Multiple outlet strip can be used for multiple power cords of non-EUT equipment.
  - (3.3) LISN at least 80 cm from nearest part of EUT chassis.
- (4) Cables of hand-operated devices, such as keyboards, mice, etc., shall be placed as for normal use.
- (5) Non-EUT components of EUT system being tested.
- (6) Rear of EUT, including peripherals, shall all be aligned and flush with rear of tabletop.
- (7) Rear of tabletop shall be 40 cm removed from a vertical conducting plane that is bonded to the ground plane.

#### 4.1.5. Test Deviation

There is no deviation with the original standard.

#### 4.1.6. EUT Operation during Test

The EUT was placed on the test table and programmed in normal function.

4.1.7. Results of AC Power Line Conducted Emissions Measurement

Temperature	26°C	Humidity	62%
Test Engineer	Deven Huang	Phase	Line
Configuration	CTX		

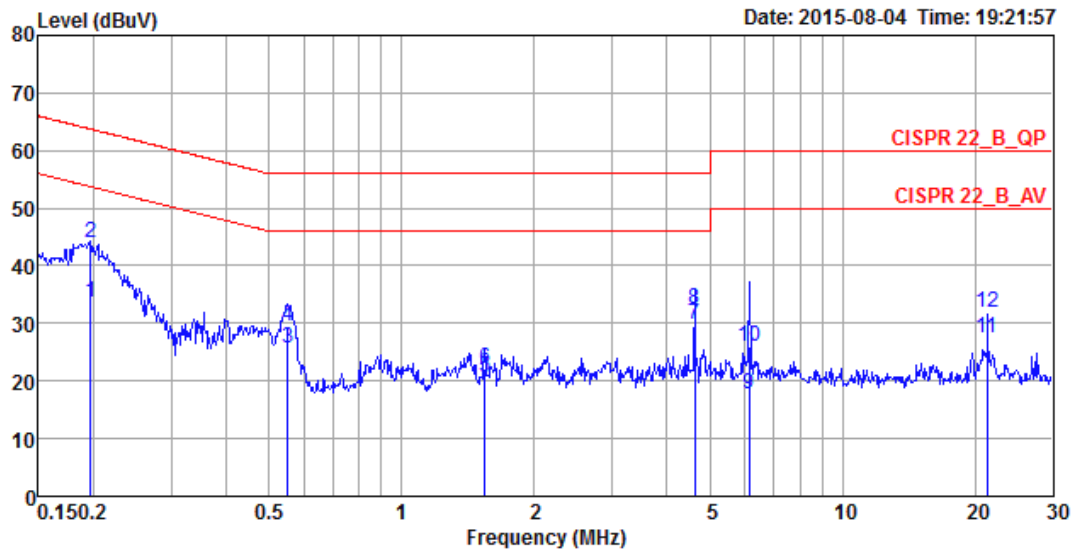

	Freq	Level	Over Limit	Limit Line	Read Level	LISN Factor	Cable Loss	Pol/Phase	Remark
	MHz	dBuV	dB	dBuV	dBuV	dB	dB		
1	0.1965	33.57	-20.19	53.76	23.62	9.93	0.02	LINE	Average
2	0.1965	44.13	-19.63	63.76	34.18	9.93	0.02	LINE	QP
3	0.5523	25.68	-20.32	46.00	15.70	9.94	0.04	LINE	Average
4	0.5523	29.65	-26.35	56.00	19.67	9.94	0.04	LINE	QP
5	1.5436	20.79	-25.21	46.00	10.75	9.98	0.06	LINE	Average
6	1.5436	22.11	-33.89	56.00	12.07	9.98	0.06	LINE	QP
7	4.6223	29.81	-16.19	46.00	19.68	10.04	0.09	LINE	Average
8	4.6223	32.39	-23.61	56.00	22.26	10.04	0.09	LINE	QP
9	6.1534	17.60	-32.40	50.00	7.37	10.10	0.13	LINE	Average
10	6.1534	25.86	-34.14	60.00	15.63	10.10	0.13	LINE	QP
11	21.2596	27.54	-22.46	50.00	16.79	10.48	0.27	LINE	Average
12	21.2596	31.91	-28.09	60.00	21.16	10.48	0.27	LINE	QP

Temperature	26°C	Humidity	62%
Test Engineer	Deven Huang	Phase	Neutral
Configuration	CTX		

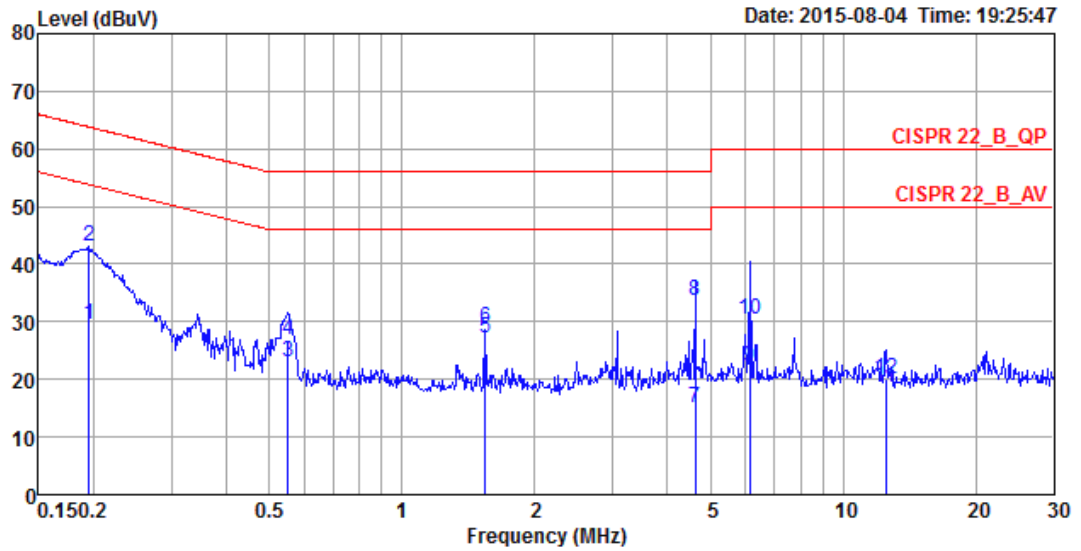

	Freq	Level	Over Limit	Limit Line	Read Level	LISN Factor	Cable Loss	Pol/Phase	Remark
	MHz	dBuV	dB	dBuV	dBuV	dB	dB		
1	0.1955	29.54	-24.26	53.80	19.73	9.79	0.02	NEUTRAL	Average
2	0.1955	43.05	-20.75	63.80	33.24	9.79	0.02	NEUTRAL	QP
3	0.5523	22.89	-23.11	46.00	13.05	9.80	0.04	NEUTRAL	Average
4	0.5523	26.96	-29.04	56.00	17.12	9.80	0.04	NEUTRAL	QP
5	1.5436	27.12	-18.88	46.00	17.23	9.83	0.06	NEUTRAL	Average
6	1.5436	28.92	-27.08	56.00	19.03	9.83	0.06	NEUTRAL	QP
7	4.6223	15.05	-30.95	46.00	5.07	9.89	0.09	NEUTRAL	Average
8	4.6223	33.77	-22.23	56.00	23.79	9.89	0.09	NEUTRAL	QP
9	6.1534	22.14	-27.86	50.00	12.07	9.94	0.13	NEUTRAL	Average
10	6.1534	30.44	-29.56	60.00	20.37	9.94	0.13	NEUTRAL	QP
11	12.5156	18.72	-31.28	50.00	8.41	10.06	0.25	NEUTRAL	Average
12	12.5156	20.04	-39.96	60.00	9.73	10.06	0.25	NEUTRAL	QP

Note:

Level = Read Level + LISN Factor + Cable Loss.

## 4.2. Maximum Conducted Output Power Measurement

### 4.2.1. Limit

The limit for output power is 30dBm.

### 4.2.2. Measuring Instruments and Setting

Please refer to section 5 of equipments list in this report. The following table is the setting of the power meter.

Power Meter Parameter	Setting
Bandwidth	50MHz bandwidth is greater than the EUT emission bandwidth
Detector	Average

### 4.2.3. Test Procedures

1. Test procedures refer KDB558074 D01 v03r03 section 9.2.3.2 Measurement using a power meter (PM).
2. Multiple antenna systems was performed in accordance with KDB 662911 D01 v02r01 Emissions Testing of Transmitters with Multiple Outputs in the Same Band.
3. This procedure provides an alternative for determining the RMS output power using a broadband RF average power meter with a thermocouple detector.

### 4.2.4. Test Setup Layout

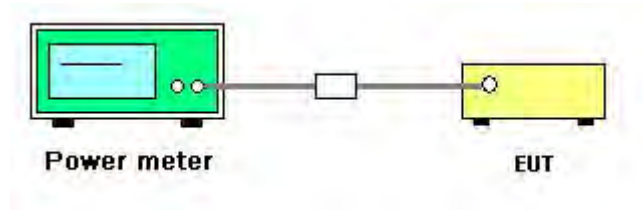

### 4.2.5. Test Deviation

There is no deviation with the original standard.

### 4.2.6. EUT Operation during Test

The EUT was programmed to be in continuously transmitting mode.

#### 4.2.7. Test Result of Maximum Conducted Output Power

Temperature	25°C	Humidity	45%
Test Engineer	Roki Liu	Test Date	Jul. 29, 2015

Mode	Frequency	Conducted Power (dBm)			Max. Limit (dBm)	Result
		Chain 2				
802.11b	2412 MHz	21.36			30.00	Complies
	2437 MHz	21.63			30.00	Complies
	2462 MHz	21.14			30.00	Complies

Mode	Frequency	Conducted Power (dBm)			Max. Limit (dBm)	Result
		Chain 1	Chain 2	Total		
802.11g	2412 MHz	17.67	17.96	20.83	30.00	Complies
	2437 MHz	24.38	25.46	27.96	30.00	Complies
	2462 MHz	18.49	18.97	21.75	30.00	Complies
802.11n MCS0 HT20	2412 MHz	16.58	16.91	19.76	30.00	Complies
	2437 MHz	23.93	25.21	27.63	30.00	Complies
	2462 MHz	18.03	18.39	21.22	30.00	Complies
802.11n MCS0 HT40	2422 MHz	12.86	14.12	16.55	30.00	Complies
	2437 MHz	16.33	17.85	20.17	30.00	Complies
	2452 MHz	12.54	14.44	16.60	30.00	Complies

### 4.3. Power Spectral Density Measurement

#### 4.3.1. Limit

For digitally modulated systems, the power spectral density conducted from the intentional radiator to the antenna shall not be greater than 8 dBm in any 3 kHz band during any time interval of continuous transmission.

#### 4.3.2. Measuring Instruments and Setting

Please refer to section 5 of equipments list in this report. The following table is the setting of the spectrum analyzer.

Spectrum Parameter	Setting
Attenuation	Auto
Span Frequency	Set the span to 1.5 times the DTS channel bandwidth.
RBW	$3 \text{ kHz} \leq \text{RBW} \leq 100\text{kHz}$
VBW	$\geq 3 \times \text{RBW}$
Detector	Peak
Trace	Max Hold
Sweep Time	Auto couple

#### 4.3.3. Test Procedures

1. Test was performed in accordance with KDB558074 D01 v03r03 for Performing Compliance Measurements on Digital Transmission Systems (DTS) - section 10.2 Method PKPSD (peak PSD) and KDB 662911 D01 v02r01 section In-Band Power Spectral Density (PSD) Measurements option (b) Measure and sum spectral maximal across the outputs.
2. Use this procedure when the maximum conducted output power in the fundamental emission is used to demonstrate compliance. The EUT must be configured to transmit continuously at full power over the measurement duration.
3. Ensure that the number of measurement points in the sweep  $\geq 2 \times \text{span}/\text{RBW}$  (use of a greater number of measurement points than this minimum requirement is recommended).
4. Use the peak marker function to determine the maximum level in any 3 kHz band segment within the fundamental EBW.
5. The resulting PSD level must be  $\leq 8 \text{ dBm}$ .

#### 4.3.4. Test Setup Layout

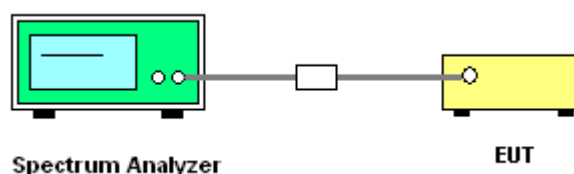

#### 4.3.5. Test Deviation

There is no deviation with the original standard.

#### 4.3.6. EUT Operation during Test

The EUT was programmed to be in continuously transmitting mode.

#### 4.3.7. Test Result of Power Spectral Density

Temperature	25°C	Humidity	45%
Test Engineer	Roki Liu		

Mode	Frequency	Power Density (dBm/3kHz)		Power Density Limit (dBm/3kHz)	Result
		Chain 2			
802.11b	2412 MHz	-2.58		7.32	Complies
	2437 MHz	-2.36		7.43	Complies
	2462 MHz	-2.34		7.49	Complies

Mode	Frequency	Power Density (dBm/3kHz)			Power Density Limit (dBm/3kHz)	Result
		Chain 1	Chain 2	Total		
802.11g	2412 MHz	-8.00	-7.10	-4.52	7.32	Complies
	2437 MHz	-0.58	1.44	3.56	7.43	Complies
	2462 MHz	-7.13	-6.71	-3.90	7.49	Complies
802.11n MCS0 HT20	2412 MHz	-10.57	-9.43	-6.95	7.32	Complies
	2437 MHz	-2.81	0.13	1.91	7.43	Complies
	2462 MHz	-8.25	-7.61	-4.91	7.49	Complies
802.11n MCS0 HT40	2422 MHz	-16.96	-14.65	-12.64	7.32	Complies
	2437 MHz	-12.92	-11.22	-8.98	7.43	Complies
	2452 MHz	-16.77	-14.50	-12.48	7.49	Complies

Note:

$$2412\text{MHz: } \textit{DirectionalGain} = 10 \cdot \log \left[ \frac{\sum_{j=1}^{N_{SS}} \left\{ \sum_{k=1}^{N_{ANT}} g_{j,k} \right\}^2}{N_{ANT}} \right] = 6.68\text{dBi} > 6\text{dBi, So Limit} = 8 - (6.68 - 6) = 7.32\text{dBm/MHz}$$

$$2422\text{MHz: } \textit{DirectionalGain} = 10 \cdot \log \left[ \frac{\sum_{j=1}^{N_{SS}} \left\{ \sum_{k=1}^{N_{ANT}} g_{j,k} \right\}^2}{N_{ANT}} \right] = 6.68\text{dBi} > 6\text{dBi, So Limit} = 8 - (6.68 - 6) = 7.32\text{dBm/MHz}$$

$$2437\text{MHz: } \textit{DirectionalGain} = 10 \cdot \log \left[ \frac{\sum_{j=1}^{N_{SS}} \left\{ \sum_{k=1}^{N_{ANT}} g_{j,k} \right\}^2}{N_{ANT}} \right] = 6.57\text{dBi} > 6\text{dBi, So Limit} = 8 - (6.57 - 6) = 7.43\text{dBm/MHz}$$



$$\begin{aligned}
 2452\text{MHz: } \textit{DirectionalGain} &= 10 \cdot \log \left[ \frac{\sum_{j=1}^{N_{SS}} \left\{ \sum_{k=1}^{N_{ANT}} g_{j,k} \right\}^2}{N_{ANT}} \right] = 6.51 \text{ dBi} > 6 \text{ dBi, So Limit} = 8 - (6.51 - 6) = 7.49 \text{ dBm/MHz} \\
 2462\text{MHz: } \textit{DirectionalGain} &= 10 \cdot \log \left[ \frac{\sum_{j=1}^{N_{SS}} \left\{ \sum_{k=1}^{N_{ANT}} g_{j,k} \right\}^2}{N_{ANT}} \right] = 6.51 \text{ dBi} > 6 \text{ dBi, So Limit} = 8 - (6.51 - 6) = 7.49 \text{ dBm/MHz}
 \end{aligned}$$

Note: All the test values were listed in the report.

For plots, only the channel with worse result was shown.

**Power Density Plot on Configuration IEEE 802.11b / 2462 MHz / Chain 2**



Date: 29.JUL.2015 10:42:32

**Power Density Plot on Configuration IEEE 802.11g / 2437 MHz / Chain 1**

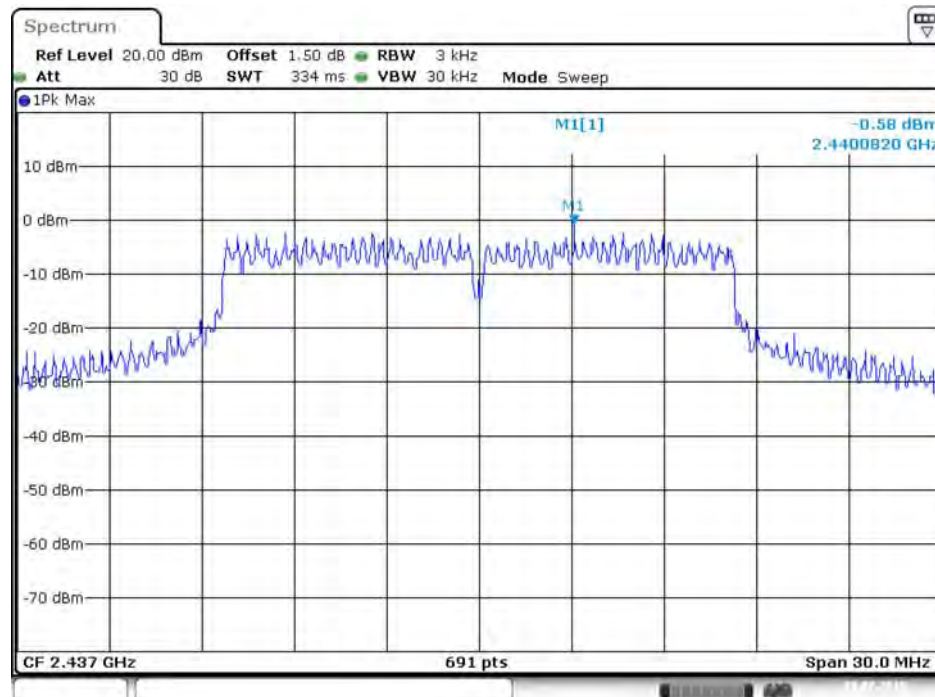

Date: 29.JUL.2015 10:47:10

**Power Density Plot on Configuration IEEE 802.11g / 2437 MHz / Chain 2**

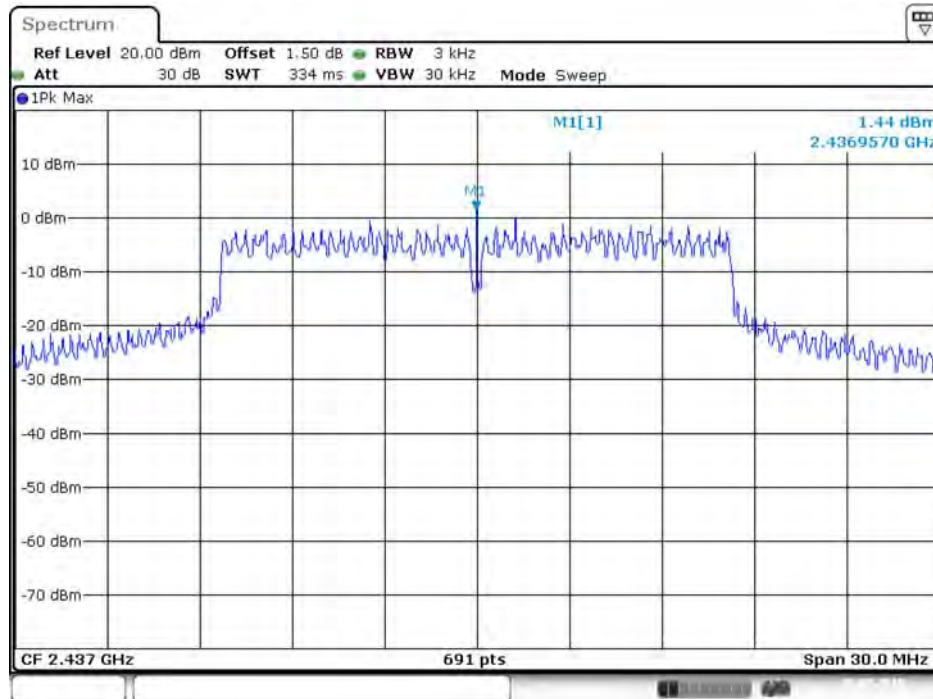

Date: 29 JUL 2015 10:46:34

**Power Density Plot on Configuration IEEE 802.11n MCS0 HT20 / 2437 MHz / Chain 1**

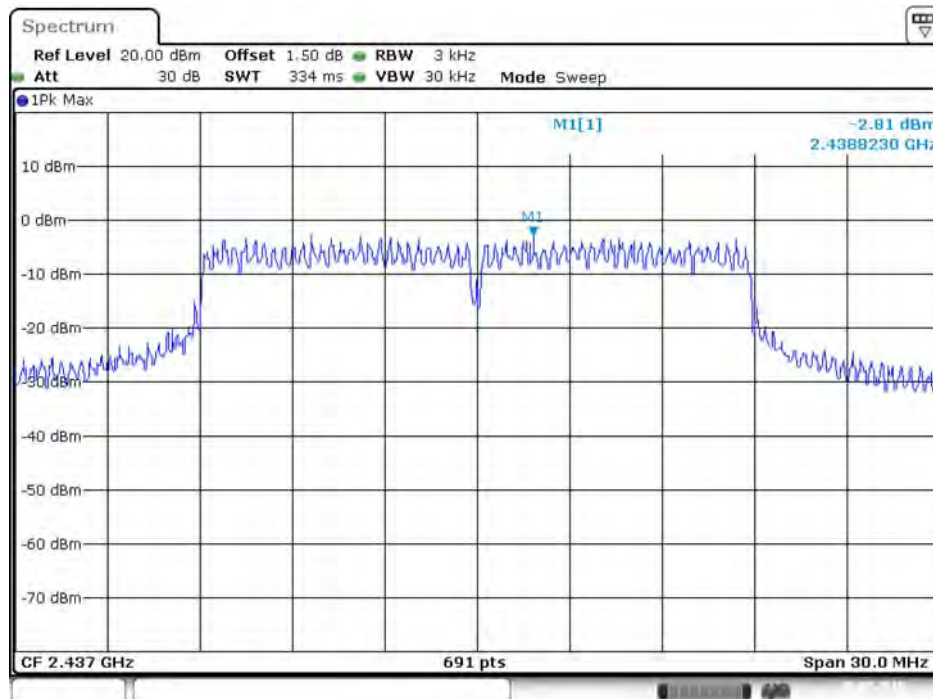

Date: 29 JUL 2015 10:51:23

**Power Density Plot on Configuration IEEE 802.11n MCS0 HT20 / 2437 MHz / Chain 2**

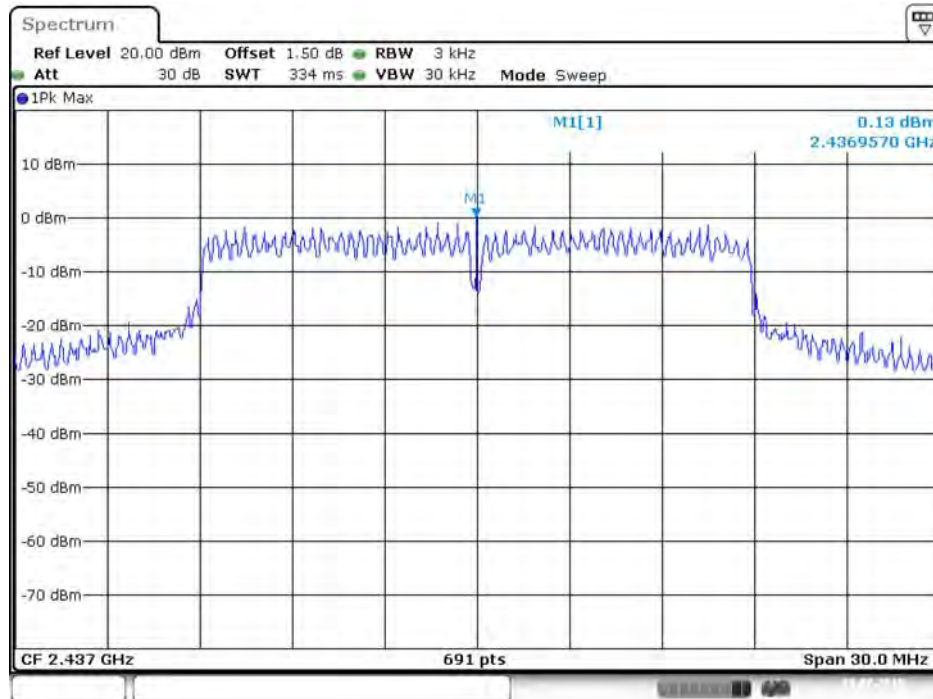

Date: 29.JUL.2015 10:52:27

**Power Density Plot on Configuration IEEE 802.11n MCS0 HT40 / 2437 MHz / Chain 1**

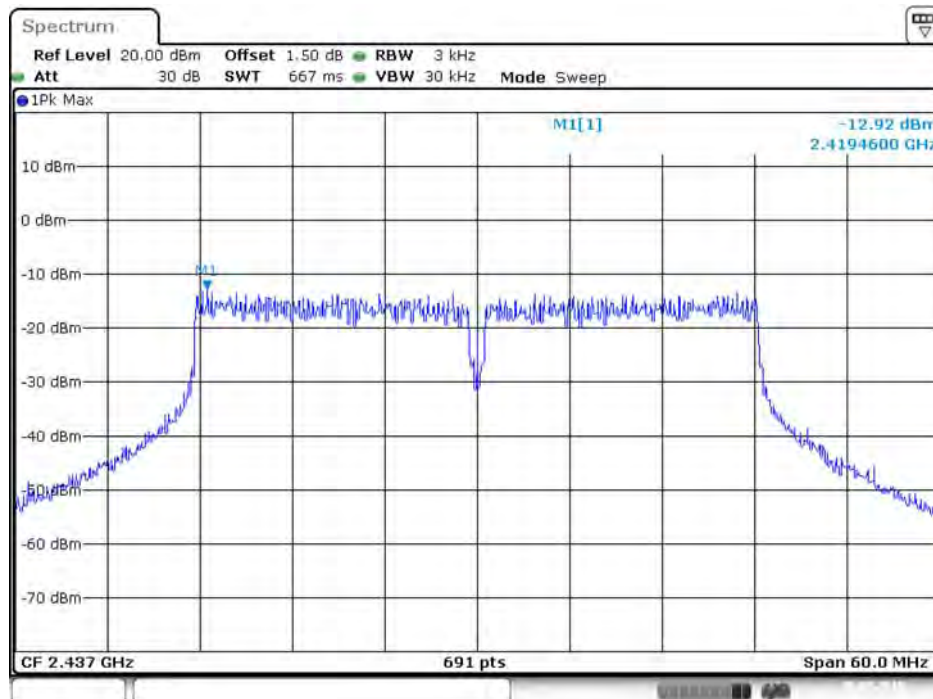

Date: 29.JUL.2015 10:58:53

### Power Density Plot on Configuration IEEE 802.11n MCS0 HT40 / 2437 MHz / Chain 2

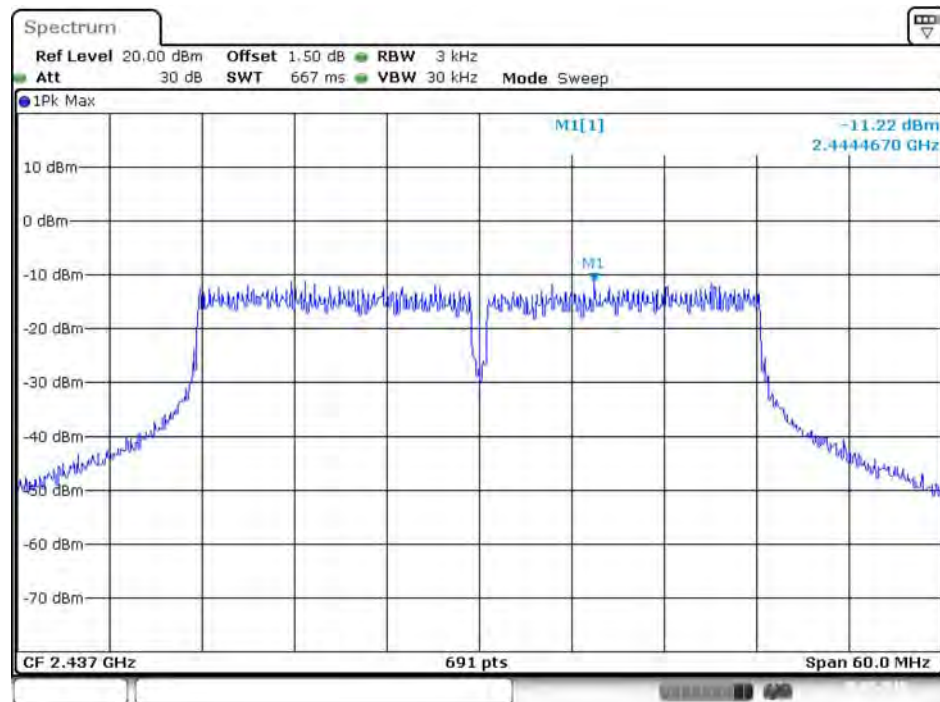

Date: 29 JUL 2015 10:57:54

## 4.4. 6dB Spectrum Bandwidth Measurement

### 4.4.1. Limit

For digital modulation systems, the minimum 6 dB bandwidth shall be at least 500 kHz.

### 4.4.2. Measuring Instruments and Setting

Please refer to section 5 of equipments list in this report. The following table is the setting of the Spectrum Analyzer.

6dB Spectrum Bandwidth	
Spectrum Parameters	Setting
Attenuation	Auto
Span Frequency	> 6dB Bandwidth
RBW	100kHz
VBW	$\geq 3 \times \text{RBW}$
Detector	Peak
Trace	Max Hold
Sweep Time	Auto
99% Occupied Bandwidth	
Spectrum Parameters	Setting
Span	1.5 times to 5.0 times the OBW
RBW	1 % to 5 % of the OBW
VBW	$\geq 3 \times \text{RBW}$
Detector	Peak
Trace	Max Hold

### 4.4.3. Test Procedures

For Radiated 6dB Bandwidth Measurement:

1. The transmitter was radiated to the spectrum analyzer in peak hold mode.
2. Test was performed in accordance with KDB558074 D01 v03r03 for Performing Compliance Measurements on Digital Transmission Systems (DTS) - section 8.0 DTS bandwidth = > 8.1 Option 1.
3. Multiple antenna system was performed in accordance with KDB 662911 D01 v02r01 Emissions Testing of Transmitters with Multiple Outputs in the Same Band.
4. Measured the spectrum width with power higher than 6dB below carrier.

### 4.4.4. Test Setup Layout

For Radiated 6dB Bandwidth Measurement:

This test setup layout is the same as that shown in section 4.5.4.

#### **4.4.5. Test Deviation**

There is no deviation with the original standard.

#### **4.4.6. EUT Operation during Test**

The EUT was programmed to be in continuously transmitting mode.

#### 4.4.7. Test Result of 6dB Spectrum Bandwidth

<b>Temperature</b>	25°C	<b>Humidity</b>	45%
<b>Test Engineer</b>	Roki Liu		

Mode	Frequency	6dB Bandwidth (MHz)	99% Occupied Bandwidth (MHz)	Min. Limit (kHz)	Test Result
802.11b	2412 MHz	10.03	13.98	500	Complies
	2437 MHz	10.03	13.98	500	Complies
	2462 MHz	10.03	13.98	500	Complies
802.11g	2412 MHz	16.12	16.85	500	Complies
	2437 MHz	12.17	27.96	500	Complies
	2462 MHz	16.12	16.50	500	Complies
802.11n MCS0 HT20	2412 MHz	12.17	17.19	500	Complies
	2437 MHz	17.57	27.18	500	Complies
	2462 MHz	17.57	18.41	500	Complies
802.11n MCS0 HT40	2422 MHz	35.36	39.22	500	Complies
	2437 MHz	36.41	37.34	500	Complies
	2452 MHz	35.48	39.07	500	Complies

Note: All the test values were listed in the report.

For plots, only the channel with worse result was shown.



6 dB Bandwidth Plot on Configuration IEEE 802.11b / 2412 MHz / Chain 2

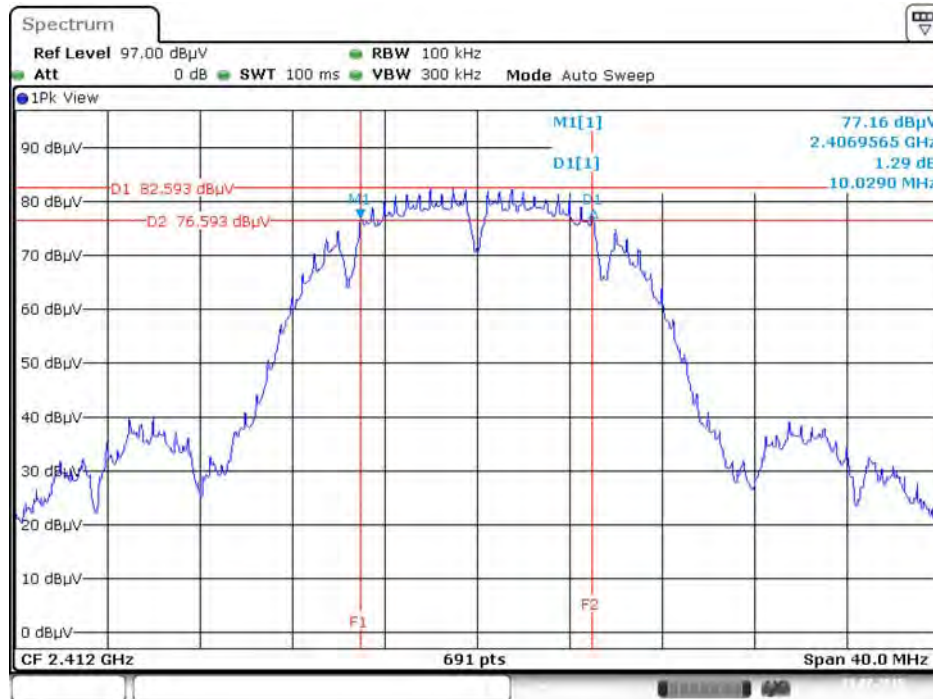

Date: 29.JUL.2015 11:12:08

99% Occupied Bandwidth Plot on Configuration IEEE 802.11b / 2412 MHz / Chain 2

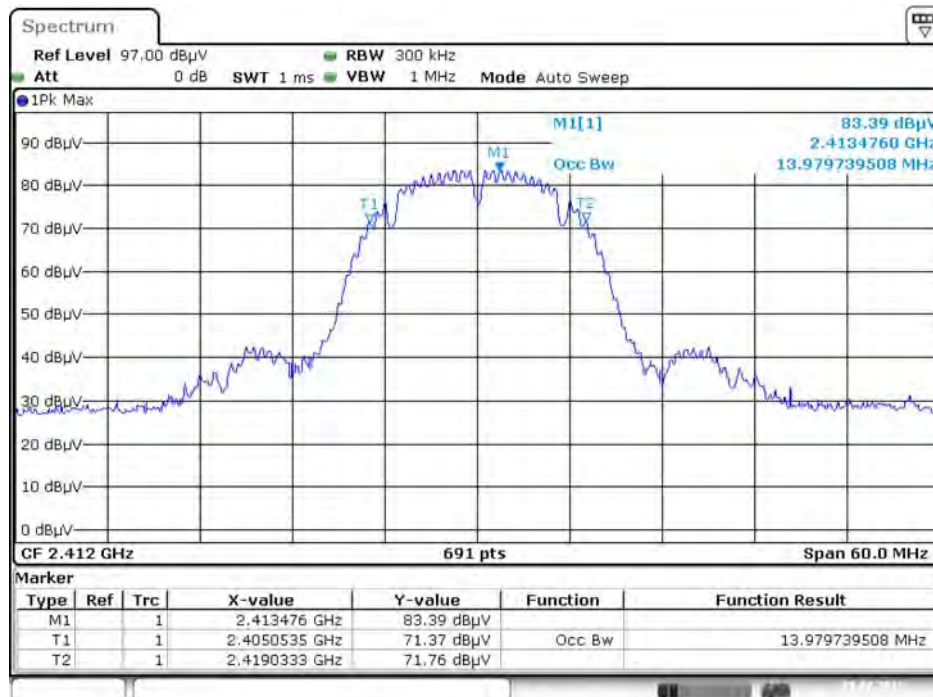

Date: 29.JUL.2015 11:25:41

6 dB Bandwidth Plot on Configuration IEEE 802.11g / 2437 MHz / Chain 1 + Chain 2



Date: 29.JUL.2015 11:13:38

99% Occupied Bandwidth Plot on Configuration IEEE 802.11g / 2437 MHz / Chain 1 + Chain 2



Date: 29.JUL.2015 11:29:21

6 dB Bandwidth Plot on Configuration IEEE 802.11n MCS0 HT20 / 2412 MHz / Chain 1 + Chain 2

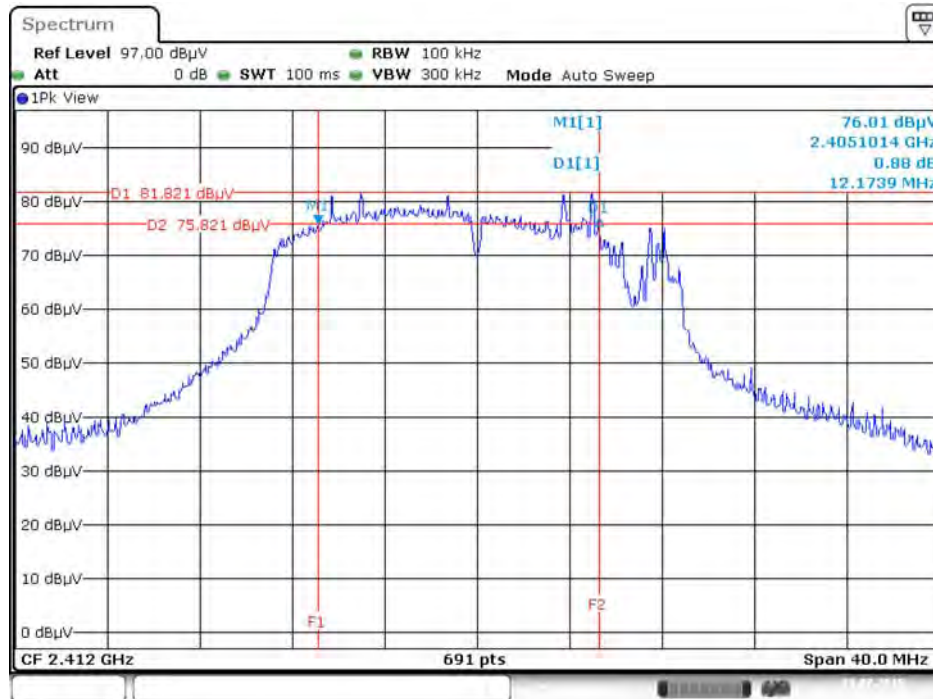

Date: 29.JUL.2015 11:16:59

99% Occupied Bandwidth Plot on Configuration IEEE 802.11n MCS0 HT20 / 2437 MHz / Chain 1 + Chain 2

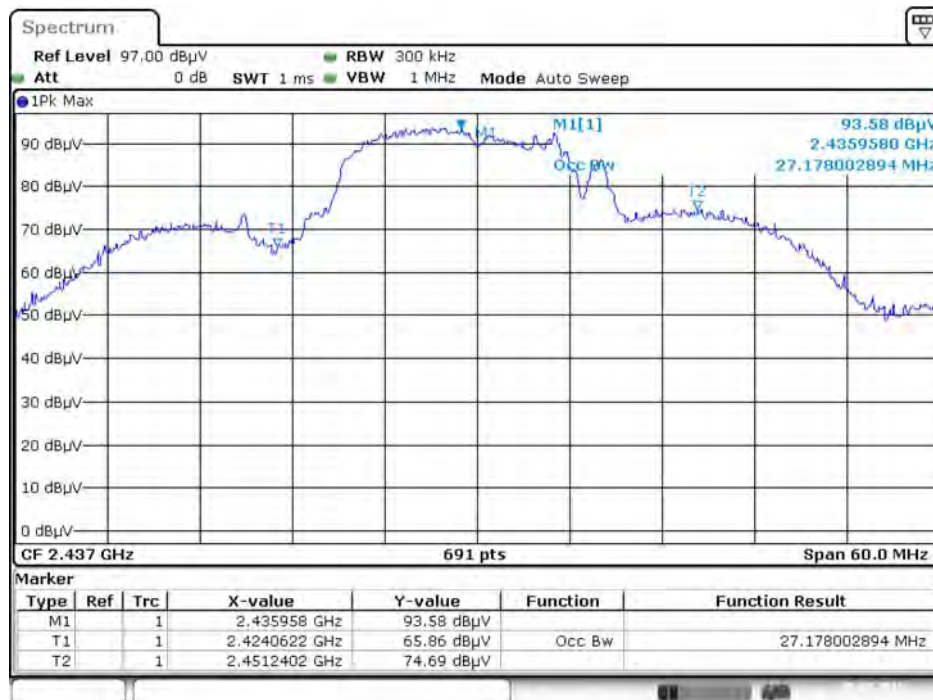

Date: 29.JUL.2015 11:31:56

6 dB Bandwidth Plot on Configuration IEEE 802.11n MCS0 HT40 / 2422 MHz / Chain 1 + Chain 2

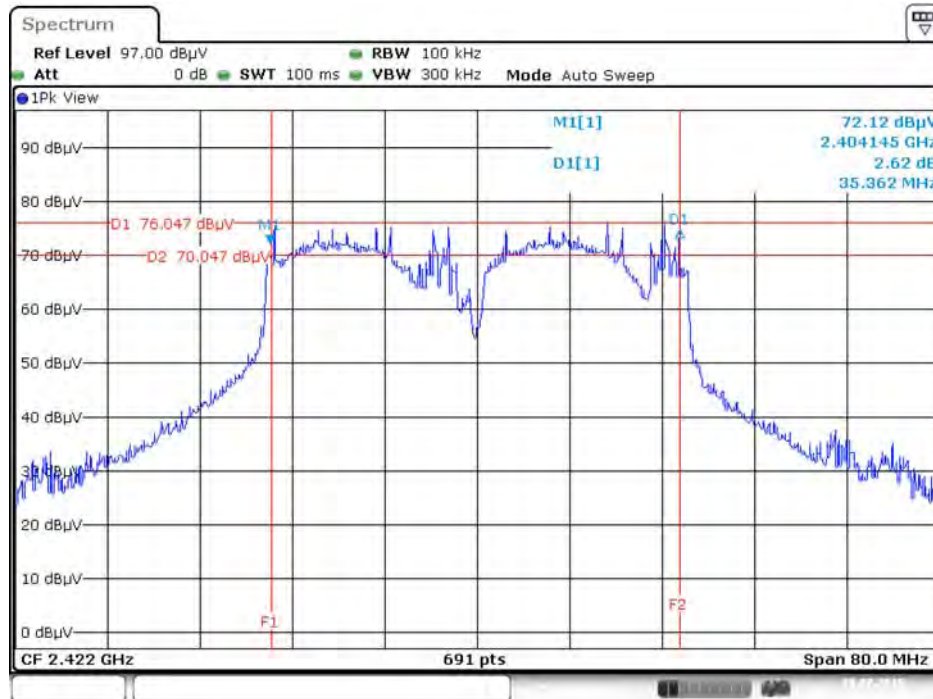

Date: 29.JUL.2015 11:20:34

99% Occupied Bandwidth Plot on Configuration IEEE 802.11n MCS0 HT40 / 2422 MHz / Chain 1 + Chain 2



Date: 29.JUL.2015 11:33:45

## 4.5. Radiated Emissions Measurement

### 4.5.1. Limit

30dBc in any 100 kHz bandwidth outside the operating frequency band. In case the emission fall within the restricted band specified on 15.205(a), then the 15.209(a) limit in the table below has to be followed.

Frequencies (MHz)	Field Strength (micorvolts/meter)	Measurement Distance (meters)
0.009~0.490	2400/F(kHz)	300
0.490~1.705	24000/F(kHz)	30
1.705~30.0	30	30
30~88	100	3
88~216	150	3
216~960	200	3
Above 960	500	3

### 4.5.2. Measuring Instruments and Setting

Please refer to section 5 of equipments list in this report. The following table is the setting of spectrum analyzer and receiver.

Spectrum Parameter	Setting
Attenuation	Auto
Start Frequency	1000 MHz
Stop Frequency	10th carrier harmonic
RBW / VBW (Emission in restricted band)	1MHz / 3MHz for Peak, 1MHz / 1/T for Average
RBW / VBW (Emission in non-restricted band)	100kHz / 300kHz for peak

Receiver Parameter	Setting
Attenuation	Auto
Start ~ Stop Frequency	9kHz~150kHz / RBW 200Hz for QP
Start ~ Stop Frequency	150kHz~30MHz / RBW 9kHz for QP
Start ~ Stop Frequency	30MHz~1000MHz / RBW 120kHz for QP

#### 4.5.3. Test Procedures

1. Configure the EUT according to ANSI C63.10. The EUT was placed on the top of the turntable 1.5 meter above ground. The phase center of the receiving antenna mounted on the top of a height-variable antenna tower was placed 1m & 3m far away from the turntable.
2. Power on the EUT and all the supporting units. The turntable was rotated by 360 degrees to determine the position of the highest radiation.
3. The height of the broadband receiving antenna was varied between one meter and four meters above ground to find the maximum emissions field strength of both horizontal and vertical polarization.
4. For each suspected emissions, the antenna tower was scan (from 1 m to 4 m) and then the turntable was rotated (from 0 degree to 360 degrees) to find the maximum reading.
5. Set the test-receiver system to Peak or CISPR quasi-peak Detect Function with specified bandwidth under Maximum Hold Mode.
6. For emissions above 1GHz, use 1MHz VBW and 3MHz RBW for peak reading. Then 1MHz RBW and 1/T VBW for average reading in spectrum analyzer.
7. If the emissions level of the EUT in peak mode was 3 dB lower than the average limit specified, then testing will be stopped and peak values of EUT will be reported, otherwise, the emissions which do not have 3 dB margin will be repeated one by one using the quasi-peak method for below 1GHz.
8. For testing above 1GHz, the emissions level of the EUT in peak mode was lower than average limit (that means the emissions level in peak mode also complies with the limit in average mode), then testing will be stopped and peak values of EUT will be reported, otherwise, the emissions will be measured in average mode again and reported.
9. In case the emission is lower than 30MHz, loop antenna has to be used for measurement and the recorded data should be QP measured by receiver. High – Low scan is not required in this case.

#### 4.5.4. Test Setup Layout

For Radiated Emissions: 9kHz ~30MHz

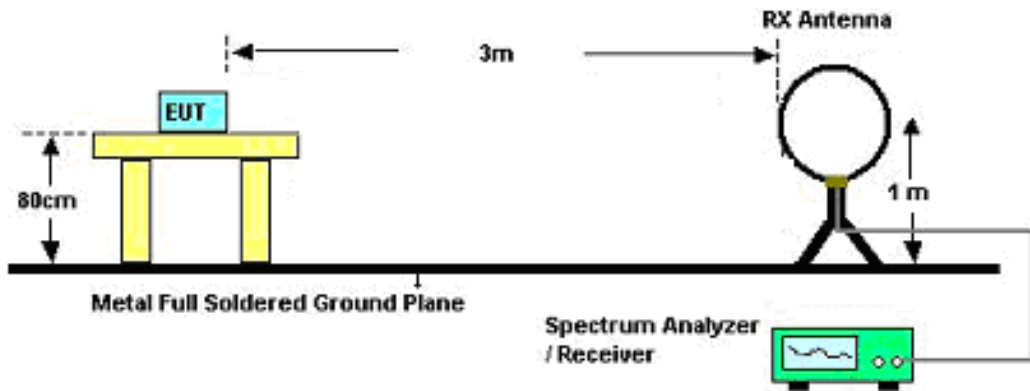

For Radiated Emissions: 30MHz~1GHz

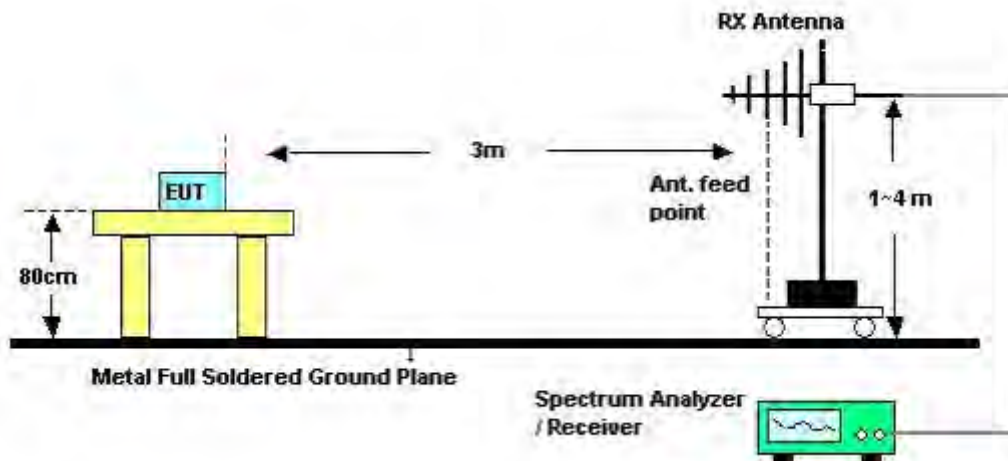

For Radiated Emissions: Above 1GHz

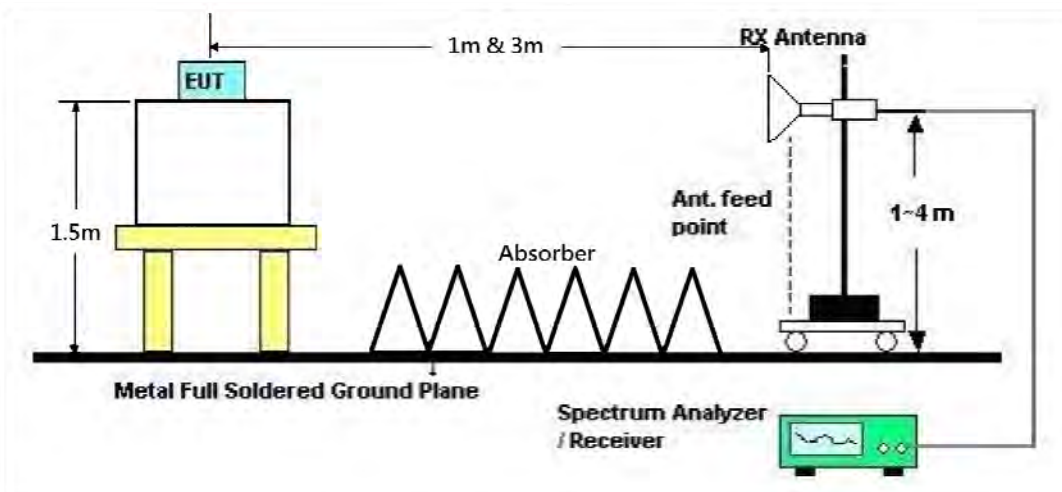

#### 4.5.5. Test Deviation

There is no deviation with the original standard.

#### 4.5.6. EUT Operation during Test

The EUT was programmed to be in continuously transmitting mode.



#### 4.5.7. Results of Radiated Emissions (9kHz~30MHz)

Temperature	24°C	Humidity	55%
Test Engineer	JC Yang	Configurations	CTX
Test Date	Aug. 04, 2015		

Freq. (MHz)	Level (dBuV)	Over Limit (dB)	Limit Line (dBuV)	Remark
-	-	-	-	See Note

**Note:**

The amplitude of spurious emissions which are attenuated by more than 20 dB below the permissible value has no need to be reported.

Distance extrapolation factor =  $40 \log(\text{specific distance} / \text{test distance})$  (dB);

Limit line = specific limits (dBuV) + distance extrapolation factor.

4.5.8. Results of Radiated Emissions (30MHz~1GHz)

Temperature	24°C	Humidity	55%
Test Engineer	JC Yang	Configurations	CTX

Horizontal

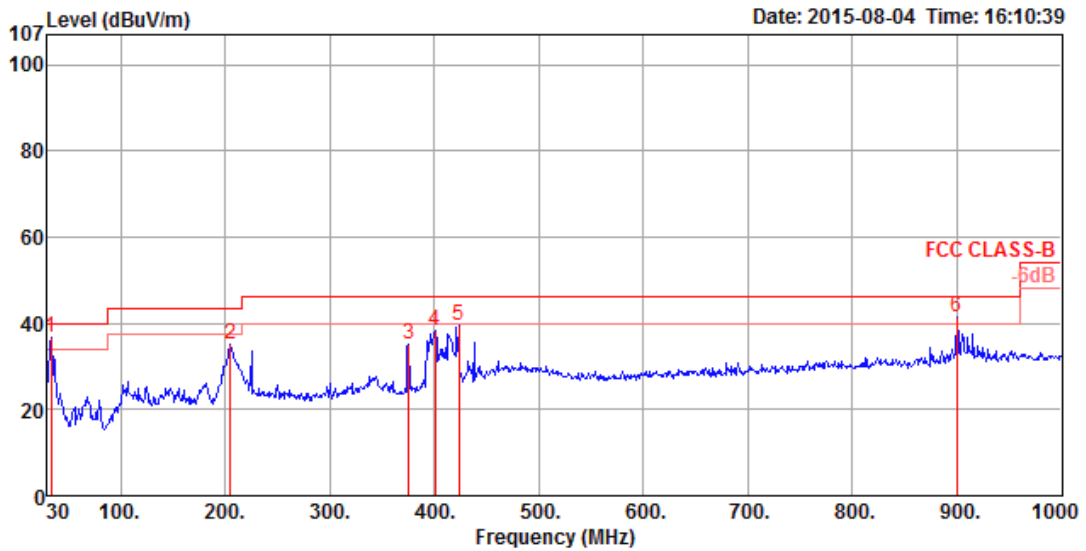

	Freq	Level	Limit	Over	ReadAntenna	Cable	Preamp	A/Pos	T/Pos	Pol/Phase	Remark
	MHz	dBuV/m	dBuV/m	dB	dBuV	dB/m	dB	dB	cm	deg	
1	33.88	36.87	40.00	-3.13	51.31	17.61	0.59	32.64	200	49	HORIZONTAL Peak
2	204.60	34.97	43.50	-8.53	55.61	10.50	1.41	32.55	100	194	HORIZONTAL Peak
3	375.32	35.05	46.00	-10.95	49.73	15.93	1.93	32.54	100	6	HORIZONTAL Peak
4	400.54	38.48	46.00	-7.52	52.53	16.50	1.99	32.54	200	356	HORIZONTAL Peak
5	423.82	39.56	46.00	-6.44	53.28	16.79	2.05	32.56	200	348	HORIZONTAL Peak
6	900.09	41.53	46.00	-4.47	48.80	21.60	2.99	31.86	150	75	HORIZONTAL Peak

**Vertical**

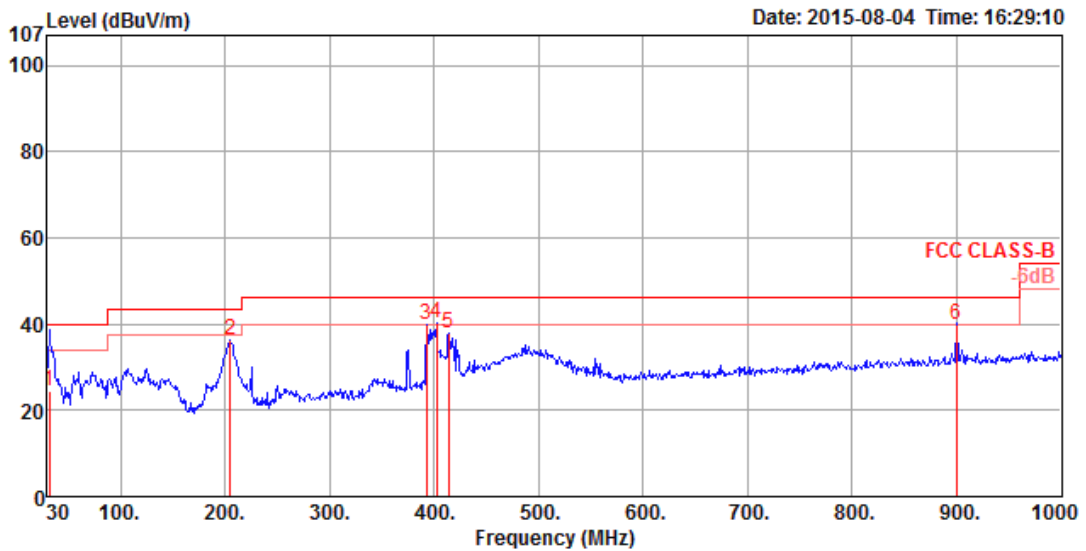

	Freq	Level	Limit	Over	ReadAntenna	Cable	Preamp	A/Pos	T/Pos	Po1/Phase	Remark
	MHz	dBuV/m	dBuV/m	dB	dBuV	dB/m	dB	dB	cm	deg	
1	31.94	24.32	40.00	-15.68	37.64	18.77	0.55	32.64	125	357	VERTICAL QP
2	204.60	36.17	43.50	-7.33	56.81	10.50	1.41	32.55	100	16	VERTICAL Peak
3	392.78	39.92	46.00	-6.08	54.18	16.31	1.97	32.54	150	360	VERTICAL Peak
4	402.48	40.32	46.00	-5.68	54.34	16.52	2.00	32.54	150	358	VERTICAL Peak
5	414.12	37.94	46.00	-8.06	51.79	16.68	2.02	32.55	125	131	VERTICAL Peak
6	900.09	39.93	46.00	-6.07	47.20	21.60	2.99	31.86	150	320	VERTICAL QP

**Note:**

The amplitude of spurious emissions which are attenuated by more than 20 dB below the permissible value has no need to be reported.

Emission level (dBuV/m) = 20 log Emission level (uV/m).

Corrected Reading: Antenna Factor + Cable Loss + Read Level - Preamp Factor = Level.

#### 4.5.9. Results for Radiated Emissions (1GHz~10<sup>th</sup> Harmonic)

<b>Temperature</b>	24°C	<b>Humidity</b>	55%
<b>Test Engineer</b>	JC Yang	<b>Configurations</b>	IEEE 802.11b CH 1 / Chain 2
<b>Test Date</b>	Jul. 07, 2015		

##### Horizontal

	Freq	Level	Limit Line	Over Limit	Read Level	CableAntenna Loss	Antenna Factor	Preamp Factor	A/Pos	T/Pos	Pol/Phase	Remark
	MHz	dBuV/m	dBuV/m	dB	dBuV	dB	dB/m	dB	cm	deg		
1	4823.92	57.70	74.00	-16.30	54.16	5.38	32.55	34.39	195	52	HORIZONTAL	Peak
2	4823.94	53.78	54.00	-0.22	50.24	5.38	32.55	34.39	195	52	HORIZONTAL	Average

##### Vertical

	Freq	Level	Limit Line	Over Limit	Read Level	CableAntenna Loss	Antenna Factor	Preamp Factor	A/Pos	T/Pos	Pol/Phase	Remark
	MHz	dBuV/m	dBuV/m	dB	dBuV	dB	dB/m	dB	cm	deg		
1	4823.88	54.41	74.00	-19.59	50.87	5.38	32.55	34.39	132	1	VERTICAL	Peak
2	4823.91	50.37	54.00	-3.63	46.83	5.38	32.55	34.39	132	1	VERTICAL	Average

<b>Temperature</b>	24°C	<b>Humidity</b>	55%
<b>Test Engineer</b>	JC Yang	<b>Configurations</b>	IEEE 802.11b CH 6 / Chain 2
<b>Test Date</b>	Jul. 07, 2015		

**Horizontal**

	Freq	Level	Limit	Over	Read	CableAntenna	Preamp	A/Pos	T/Pos	Pol/Phase	Remark
	MHz	dBuV/m	dBuV/m	dB	dBuV	dB	dB/m	dB	cm	deg	
1	4873.91	53.80	54.00	-0.20	50.12	5.40	32.66	34.38	174	55	HORIZONTAL Average
2	4873.96	57.48	74.00	-16.52	53.80	5.40	32.66	34.38	174	55	HORIZONTAL Peak

**Vertical**

	Freq	Level	Limit	Limit	Level	Loss Factor	Factor		√/Pos	T/Pos	Pol/Phase	Remark
	MHz	dBuV/m	dBuV/m	dB	dBuV	dB	dB/m	dB	cm	deg		
1	4873.94	52.85	54.00	-1.15	49.17	5.40	32.66	34.38	121	341	VERTICAL	Average
2	4874.04	56.42	74.00	-17.58	52.74	5.40	32.66	34.38	121	341	VERTICAL	Peak

<b>Temperature</b>	24°C	<b>Humidity</b>	55%
<b>Test Engineer</b>	JC Yang	<b>Configurations</b>	IEEE 802.11b CH 11 / Chain 2
<b>Test Date</b>	Jul. 07, 2015		

### Horizontal

	Freq	Level	Limit Line	Over Limit	Read Level	CableAntenna Loss	Antenna Factor	Preamp Factor	A/Pos	T/Pos	Pol/Phase	Remark
	MHz	dBuV/m	dBuV/m	dB	dBuV	dB	dB/m	dB	cm	deg		
1	4923.83	57.48	74.00	-16.52	53.67	5.42	32.76	34.37	200	28	HORIZONTAL	Peak
2	4923.93	53.55	54.00	-0.45	49.74	5.42	32.76	34.37	200	28	HORIZONTAL	Average

### Vertical

	Freq	Level	Limit Line	Over Limit	Read Level	CableAntenna Loss	Antenna Factor	Preamp Factor	A/Pos	T/Pos	Pol/Phase	Remark
	MHz	dBuV/m	dBuV/m	dB	dBuV	dB	dB/m	dB	cm	deg		
1	4923.94	52.71	54.00	-1.29	48.90	5.42	32.76	34.37	131	347	VERTICAL	Average
2	4924.01	56.31	74.00	-17.69	52.50	5.42	32.76	34.37	131	347	VERTICAL	Peak

<b>Temperature</b>	24°C	<b>Humidity</b>	55%
<b>Test Engineer</b>	JC Yang	<b>Configurations</b>	IEEE 802.11g CH 1 / Chain 1 + Chain 2
<b>Test Date</b>	Jul. 09, 2015		

### Horizontal

	Freq	Level	Limit Line	Over Limit	Read Level	CableAntenna Loss	Antenna Factor	Preamp Factor	T/Pos	A/Pos	Remark	Pol/Phase
	MHz	dBuV/m	dBuV/m	dB	dBuV	dB	dB/m	dB	deg	cm		
1	3215.92	49.92	74.00	-24.08	51.49	3.30	29.78	34.65	262	182	Peak	HORIZONTAL
2	3215.95	46.21	54.00	-7.79	47.78	3.30	29.78	34.65	262	182	Average	HORIZONTAL
3	4823.80	51.36	74.00	-22.64	49.09	4.10	32.69	34.52	344	137	Peak	HORIZONTAL
4	4823.84	36.66	54.00	-17.34	34.39	4.10	32.69	34.52	344	137	Average	HORIZONTAL

### Vertical

	Freq	Level	Limit Line	Over Limit	Read Level	CableAntenna Loss	Antenna Factor	Preamp Factor	T/Pos	A/Pos	Remark	Pol/Phase
	MHz	dBuV/m	dBuV/m	dB	dBuV	dB	dB/m	dB	deg	cm		
1	3215.92	48.81	74.00	-25.19	50.38	3.30	29.78	34.65	177	173	Peak	VERTICAL
2	3215.97	44.56	54.00	-9.44	46.13	3.30	29.78	34.65	177	173	Average	VERTICAL
3	4828.72	36.13	54.00	-17.87	33.86	4.10	32.69	34.52	320	136	Average	VERTICAL
4	4830.92	48.04	74.00	-25.96	45.77	4.10	32.69	34.52	320	136	Peak	VERTICAL

<b>Temperature</b>	24°C	<b>Humidity</b>	55%
<b>Test Engineer</b>	JC Yang	<b>Configurations</b>	IEEE 802.11g CH 6 / Chain 1 + Chain 2
<b>Test Date</b>	Jul. 09, 2015		

### Horizontal

	Freq	Level	Limit Line	Over Limit	Read Level	Cable Loss	Antenna Factor	Preamp Factor	T/Pos	A/Pos	Remark	Pol/Phase
	MHz	dBuV/m	dBuV/m	dB	dBuV	dB	dB/m	dB	deg	cm		
1	3249.17	48.12	74.00	-25.88	49.56	3.32	29.88	34.64	259	200	Peak	HORIZONTAL
2	3249.26	42.62	54.00	-11.38	44.06	3.32	29.88	34.64	259	200	Average	HORIZONTAL
3	4872.80	63.86	74.00	-10.14	61.46	4.13	32.78	34.51	19	214	Peak	HORIZONTAL
4	4873.50	50.56	54.00	-3.44	48.16	4.13	32.78	34.51	19	214	Average	HORIZONTAL
5	7307.20	46.22	54.00	-7.78	38.66	5.09	37.23	34.76	82	201	Average	HORIZONTAL
6	7307.50	59.93	74.00	-14.07	52.37	5.09	37.23	34.76	82	201	Peak	HORIZONTAL

### Vertical

	Freq	Level	Limit Line	Over Limit	Read Level	Cable Loss	Antenna Factor	Preamp Factor	T/Pos	A/Pos	Remark	Pol/Phase
	MHz	dBuV/m	dBuV/m	dB	dBuV	dB	dB/m	dB	deg	cm		
1	3249.00	46.69	74.00	-27.31	48.13	3.32	29.88	34.64	185	205	Peak	VERTICAL
2	3249.28	40.27	54.00	-13.73	41.71	3.32	29.88	34.64	185	205	Average	VERTICAL
3	4872.40	59.76	74.00	-14.24	57.36	4.13	32.78	34.51	340	124	Peak	VERTICAL
4	4873.00	47.30	54.00	-6.70	44.90	4.13	32.78	34.51	340	124	Average	VERTICAL
5	7305.90	45.45	54.00	-8.55	37.89	5.09	37.23	34.76	331	128	Average	VERTICAL
6	7320.50	58.06	74.00	-15.94	50.46	5.10	37.26	34.76	331	128	Peak	VERTICAL



<b>Temperature</b>	24°C	<b>Humidity</b>	55%
<b>Test Engineer</b>	JC Yang	<b>Configurations</b>	IEEE 802.11g CH 11 / Chain 1 + Chain 2
<b>Test Date</b>	Jul. 09, 2015		

### Horizontal

	Freq	Level	Limit Line	Over Limit	Read Level	Cable Loss	Antenna Factor	Preamp Factor	T/Pos	A/Pos	Remark	Pol/Phase
	MHz	dBuV/m	dBuV/m	dB	dBuV	dB	dB/m	dB	deg	cm		
1	3282.55	48.07	74.00	-25.93	49.39	3.34	29.97	34.63	355	174	Peak	HORIZONTAL
2	3282.58	43.26	74.00	-10.74	44.58	3.34	29.97	34.63	355	174	Average	HORIZONTAL
3	4923.30	50.74	74.00	-23.26	48.20	4.15	32.88	34.49	44	194	Peak	HORIZONTAL
4	4923.60	38.34	74.00	-15.66	35.80	4.15	32.88	34.49	44	194	Average	HORIZONTAL

### Vertical

	Freq	Level	Limit Line	Over Limit	Read Level	Cable Loss	Antenna Factor	Preamp Factor	T/Pos	A/Pos	Remark	Pol/Phase
	MHz	dBuV/m	dBuV/m	dB	dBuV	dB	dB/m	dB	deg	cm		
1	3282.58	39.78	74.00	-14.22	41.10	3.34	29.97	34.63	175	157	Average	VERTICAL
2	3282.61	46.35	74.00	-27.65	47.67	3.34	29.97	34.63	175	157	Peak	VERTICAL
3	4921.70	48.98	74.00	-25.02	46.44	4.15	32.88	34.49	41	150	Peak	VERTICAL
4	4924.00	36.97	74.00	-17.03	34.43	4.15	32.88	34.49	41	150	Average	VERTICAL

<b>Temperature</b>	24°C	<b>Humidity</b>	55%
<b>Test Engineer</b>	JC Yang	<b>Configurations</b>	IEEE 802.11n MCS0 HT20 CH 1 / Chain 1 + Chain 2
<b>Test Date</b>	Jul. 09, 2015		

### Horizontal

	Freq	Level	Limit Line	Over Limit	Read Level	CableAntenna Loss	Antenna Factor	Preamp Factor	T/Pos	A/Pos	Remark	Pol/Phase
	MHz	dBuV/m	dBuV/m	dB	dBuV	dB	dB/m	dB	deg	cm		
1	3215.87	49.49	74.00	-24.51	51.06	3.30	29.78	34.65	250	134	Peak	HORIZONTAL
2	3215.95	45.58	54.00	-8.42	47.15	3.30	29.78	34.65	250	134	Average	HORIZONTAL
3	4819.40	46.63	74.00	-27.37	44.36	4.10	32.69	34.52	358	153	Peak	HORIZONTAL
4	4823.60	35.65	54.00	-18.35	33.38	4.10	32.69	34.52	358	153	Average	HORIZONTAL

### Vertical

	Freq	Level	Limit Line	Over Limit	Read Level	CableAntenna Loss	Antenna Factor	Preamp Factor	T/Pos	A/Pos	Remark	Pol/Phase
	MHz	dBuV/m	dBuV/m	dB	dBuV	dB	dB/m	dB	deg	cm		
1	3215.94	44.20	54.00	-9.80	45.77	3.30	29.78	34.65	172	199	Average	VERTICAL
2	3215.98	48.29	74.00	-25.71	49.86	3.30	29.78	34.65	172	199	Peak	VERTICAL
3	4822.20	47.92	74.00	-26.08	45.65	4.10	32.69	34.52	350	136	Peak	VERTICAL
4	4823.80	35.25	54.00	-18.75	32.98	4.10	32.69	34.52	350	136	Average	VERTICAL

<b>Temperature</b>	24°C	<b>Humidity</b>	55%
<b>Test Engineer</b>	JC Yang	<b>Configurations</b>	IEEE 802.11n MCS0 HT20 CH 6 / Chain 1 + Chain 2
<b>Test Date</b>	Jul. 09, 2015		

### Horizontal

	Freq	Level	Limit	Over	Read	CableAntenna	Preamp	T/Pos	A/Pos	Remark	Pol/Phase
	MHz	dBuV/m	dBuV/m	dB	dBuV	dB	dB/m	dB	deg	cm	
1	3249.30	41.90	54.00	-12.10	43.34	3.32	29.88	34.64	254	202 Average	HORIZONTAL
2	3249.42	47.20	74.00	-26.80	48.64	3.32	29.88	34.64	254	202 Peak	HORIZONTAL
3	4872.40	50.60	54.00	-3.40	48.20	4.13	32.78	34.51	19	216 Average	HORIZONTAL
4	4872.60	63.85	74.00	-10.15	61.45	4.13	32.78	34.51	19	216 Peak	HORIZONTAL
5	7314.60	44.75	54.00	-9.25	37.19	5.09	37.23	34.76	84	168 Average	HORIZONTAL
6	7315.20	57.27	74.00	-16.73	49.71	5.09	37.23	34.76	84	168 Peak	HORIZONTAL

### Vertical

	Freq	Level	Limit	Over	Read	CableAntenna	Preamp	T/Pos	A/Pos	Remark	Pol/Phase
	MHz	dBuV/m	dBuV/m	dB	dBuV	dB	dB/m	dB	deg	cm	
1	3249.28	41.77	54.00	-12.23	43.21	3.32	29.88	34.64	179	184 Average	VERTICAL
2	3249.31	46.94	74.00	-27.06	48.38	3.32	29.88	34.64	179	184 Peak	VERTICAL
3	4873.20	52.38	74.00	-21.62	49.98	4.13	32.78	34.51	75	154 Peak	VERTICAL
4	4873.60	37.12	54.00	-16.88	34.72	4.13	32.78	34.51	75	154 Average	VERTICAL
5	7314.60	43.17	54.00	-10.83	35.61	5.09	37.23	34.76	80	157 Average	VERTICAL
6	7317.00	56.37	74.00	-17.63	48.77	5.10	37.26	34.76	80	157 Peak	VERTICAL

<b>Temperature</b>	24°C	<b>Humidity</b>	55%
<b>Test Engineer</b>	JC Yang	<b>Configurations</b>	IEEE 802.11n MCS0 HT20 CH 11 / Chain 1 + Chain 2
<b>Test Date</b>	Jul. 09, 2015		

### Horizontal

	Freq	Level	Limit Line	Over Limit	Read Level	CableAntenna Loss	Antenna Factor	Preamp Factor	T/Pos	A/Pos	Remark	Pol/Phase
	MHz	dBuV/m	dBuV/m	dB	dBuV	dB	dB/m	dB	deg	cm		
1	3282.62	42.75	54.00	-11.25	44.07	3.34	29.97	34.63	356	174	Average	HORIZONTAL
2	3282.66	48.16	74.00	-25.84	49.48	3.34	29.97	34.63	356	174	Peak	HORIZONTAL
3	4924.00	34.34	54.00	-19.66	31.80	4.15	32.88	34.49	220	154	Average	HORIZONTAL
4	4924.60	43.10	74.00	-30.90	40.56	4.15	32.88	34.49	220	154	Peak	HORIZONTAL

### Vertical

	Freq	Level	Limit Line	Over Limit	Read Level	CableAntenna Loss	Antenna Factor	Preamp Factor	T/Pos	A/Pos	Remark	Pol/Phase
	MHz	dBuV/m	dBuV/m	dB	dBuV	dB	dB/m	dB	deg	cm		
1	3282.51	47.23	74.00	-26.77	48.55	3.34	29.97	34.63	176	157	Peak	VERTICAL
2	3282.59	40.88	54.00	-13.12	42.20	3.34	29.97	34.63	176	157	Average	VERTICAL
3	4919.56	31.07	54.00	-22.93	28.53	4.15	32.88	34.49	193	149	Average	VERTICAL
4	4919.60	42.81	74.00	-31.19	40.27	4.15	32.88	34.49	193	149	Peak	VERTICAL

<b>Temperature</b>	24°C	<b>Humidity</b>	55%
<b>Test Engineer</b>	JC Yang	<b>Configurations</b>	IEEE 802.11n MCS0 HT40 CH 3 / Chain 1 + Chain 2
<b>Test Date</b>	Jul. 09, 2015		

### Horizontal

	Freq	Level	Limit Line	Over Limit	Read Level	CableAntenna Loss	Antenna Factor	Preamp Factor	T/Pos	A/Pos	Remark	Pol/Phase
	MHz	dBuV/m	dBuV/m	dB	dBuV	dB	dB/m	dB	deg	cm		
1	3229.18	47.72	74.00	-26.28	49.23	3.31	29.83	34.65	251	138	Peak	HORIZONTAL
2	3229.26	43.46	54.00	-10.54	44.97	3.31	29.83	34.65	251	138	Average	HORIZONTAL
3	4842.56	42.28	74.00	-31.72	39.96	4.11	32.72	34.51	180	155	Peak	HORIZONTAL
4	4845.08	30.54	54.00	-23.46	28.22	4.11	32.72	34.51	180	155	Average	HORIZONTAL

### Vertical

	Freq	Level	Limit Line	Over Limit	Read Level	CableAntenna Loss	Antenna Factor	Preamp Factor	T/Pos	A/Pos	Remark	Pol/Phase
	MHz	dBuV/m	dBuV/m	dB	dBuV	dB	dB/m	dB	deg	cm		
1	3229.26	42.55	54.00	-11.45	44.06	3.31	29.83	34.65	177	200	Average	VERTICAL
2	3229.29	47.24	74.00	-26.76	48.75	3.31	29.83	34.65	177	200	Peak	VERTICAL
3	4844.24	30.47	54.00	-23.53	28.15	4.11	32.72	34.51	185	123	Average	VERTICAL
4	4847.28	42.85	74.00	-31.15	40.53	4.11	32.72	34.51	185	123	Peak	VERTICAL

<b>Temperature</b>	24°C	<b>Humidity</b>	55%
<b>Test Engineer</b>	JC Yang	<b>Configurations</b>	IEEE 802.11n MCS0 HT40 CH 6 / Chain 1 + Chain 2
<b>Test Date</b>	Jul. 09, 2015		

### Horizontal

	Freq	Level	Limit Line	Over Limit	Read Level	CableAntenna Loss	Antenna Factor	Preamp Factor	T/Pos	A/Pos	Remark	Pol/Phase
	MHz	dBuV/m	dBuV/m	dB	dBuV	dB	dB/m	dB	deg	cm		
1	3249.12	47.54	74.00	-26.46	48.98	3.32	29.88	34.64	248	147	Peak	HORIZONTAL
2	3249.31	42.11	54.00	-11.89	43.55	3.32	29.88	34.64	248	147	Average	HORIZONTAL
3	4871.48	30.98	54.00	-23.02	28.58	4.13	32.78	34.51	168	144	Average	HORIZONTAL
4	4873.64	43.53	74.00	-30.47	41.13	4.13	32.78	34.51	168	144	Peak	HORIZONTAL

### Vertical

	Freq	Level	Limit Line	Over Limit	Read Level	CableAntenna Loss	Antenna Factor	Preamp Factor	T/Pos	A/Pos	Remark	Pol/Phase
	MHz	dBuV/m	dBuV/m	dB	dBuV	dB	dB/m	dB	deg	cm		
1	3249.39	41.87	54.00	-12.13	43.31	3.32	29.88	34.64	331	151	Average	VERTICAL
2	3249.51	49.23	74.00	-24.77	50.67	3.32	29.88	34.64	331	151	Peak	VERTICAL
3	4866.88	43.16	74.00	-30.84	40.80	4.12	32.75	34.51	175	173	Peak	VERTICAL
4	4868.72	30.78	54.00	-23.22	28.38	4.13	32.78	34.51	175	173	Average	VERTICAL

<b>Temperature</b>	24°C	<b>Humidity</b>	55%
<b>Test Engineer</b>	JC Yang	<b>Configurations</b>	IEEE 802.11n MCS0 HT40 CH 9 / Chain 1 + Chain 2
<b>Test Date</b>	Jul. 09, 2015		

### Horizontal

	Freq	Level	Limit Line	Over Limit	Read Level	CableAntenna Loss	Antenna Factor	Preamp Factor	T/Pos	A/Pos	Remark	Pol/Phase
	MHz	dBuV/m	dBuV/m	dB	dBuV	dB	dB/m	dB	deg	cm		
1	3269.27	42.31	54.00	-11.69	43.69	3.33	29.92	34.63	350	168	Average	HORIZONTAL
2	3269.31	48.01	74.00	-25.99	49.39	3.33	29.92	34.63	350	168	Peak	HORIZONTAL
3	4902.52	43.33	74.00	-30.67	40.85	4.14	32.84	34.50	156	167	Peak	HORIZONTAL
4	4908.92	30.62	54.00	-23.38	28.14	4.14	32.84	34.50	156	167	Average	HORIZONTAL

### Vertical

	Freq	Level	Limit Line	Over Limit	Read Level	CableAntenna Loss	Antenna Factor	Preamp Factor	T/Pos	A/Pos	Remark	Pol/Phase
	MHz	dBuV/m	dBuV/m	dB	dBuV	dB	dB/m	dB	deg	cm		
1	3269.29	41.96	54.00	-12.04	43.34	3.33	29.92	34.63	312	168	Average	VERTICAL
2	3269.56	47.14	74.00	-26.86	48.46	3.34	29.97	34.63	312	168	Peak	VERTICAL
3	4898.92	43.30	74.00	-30.70	40.86	4.13	32.81	34.50	166	172	Peak	VERTICAL
4	4908.40	30.35	54.00	-23.65	27.87	4.14	32.84	34.50	166	172	Average	VERTICAL

### Note:

The amplitude of spurious emissions that are attenuated by more than 20dB below the permissible value has no need to be reported.

Emission level (dBuV/m) = 20 log Emission level (uV/m).

Corrected Reading: Antenna Factor + Cable Loss + Read Level - Preamp Factor = Level.

## 4.6. Emissions Measurement

### 4.6.1. Limit

30dBc in any 100 kHz bandwidth outside the operating frequency band. In case the emission fall within the restricted band specified on 15.205(a), then the 15.209(a) limit in the table below has to be followed.

Frequencies (MHz)	Field Strength (micorvolts/meter)	Measurement Distance (meters)
0.009~0.490	2400/F(kHz)	300
0.490~1.705	24000/F(kHz)	30
1.705~30.0	30	30
30~88	100	3
88~216	150	3
216~960	200	3
Above 960	500	3

### 4.6.2. Measuring Instruments and Setting

Please refer to section 5 of equipments list in this report. The following table is the setting of the spectrum analyzer.

Spectrum Parameter	Setting
Attenuation	Auto
Span Frequency	100 MHz
RBW / VBW (Emission in restricted band)	1MHz / 3MHz for Peak, 1MHz / 1/T for Average
RBW / VBW (30dBc in any 100 kHz bandwidth emission)	100 kHz / 300 kHz for Peak

### 4.6.3. Test Procedures

#### For Radiated band edges Measurement:

1. The test procedure is the same as section 4.5.3.

#### For Radiated Out of Band Emission Measurement:

1. Test was performed in accordance with KDB558074 D01 v03r03 for Performing Compliance Measurements on Digital Transmission Systems (DTS) Operating Under §15.247 section 10.1 Unwanted Emissions into Non-Restricted Frequency Bands Measurement Procedure.



#### **4.6.4. Test Setup Layout**

For Radiated band edges Measurement:

This test setup layout is the same as that shown in section 4.5.4.

For Radiated Out of Band Emission Measurement:

This test setup layout is the same as that shown in section 4.5.4.

#### **4.6.5. Test Deviation**

There is no deviation with the original standard.

#### **4.6.6. EUT Operation during Test**

The EUT was programmed to be in continuously transmitting mode.

#### 4.6.7. Test Result of Band Edge and Fundamental Emissions

Temperature	24°C	Humidity	55%
Test Engineer	JC Yang	Configurations	IEEE 802.11b CH 1, 6, 11 / Chain 2
Test Date	Jul. 07, 2015 ~ Jul. 08, 2015		

##### Channel 1

	Freq	Level	Limit	Over	Read	CableAntenna	Preamp	A/Pos	T/Pos	Pol/Phase	Remark
	MHz	dBuV/m	dBuV/m	dB	dBuV	dB	dB/m	dB	cm	deg	
1	2386.09	47.49	54.00	-6.51	15.84	3.73	27.92	0.00	202	248	HORIZONTAL Average
2	2387.68	60.86	74.00	-13.14	29.21	3.73	27.92	0.00	202	248	HORIZONTAL Peak
3	2413.01	109.05			77.41	3.75	27.89	0.00	202	248	HORIZONTAL Peak
4	2413.74	106.31			74.67	3.75	27.89	0.00	202	248	HORIZONTAL Average

Item 3, 4 are the fundamental frequency at 2412 MHz.

##### Channel 6

	Freq	Level	Limit	Over	Read	CableAntenna	Preamp	A/Pos	T/Pos	Pol/Phase	Remark
	MHz	dBuV/m	dBuV/m	dB	dBuV	dB	dB/m	dB	cm	deg	
1	2356.14	65.44	74.00	-8.56	33.78	3.70	27.96	0.00	171	108	HORIZONTAL Peak
2	2357.87	48.72	54.00	-5.28	17.06	3.70	27.96	0.00	171	108	HORIZONTAL Average
3	2435.26	106.57			74.93	3.77	27.87	0.00	171	108	HORIZONTAL Average
4	2436.13	109.63			77.99	3.77	27.87	0.00	171	108	HORIZONTAL Peak
5	2485.82	61.05	74.00	-12.95	29.41	3.82	27.82	0.00	171	108	HORIZONTAL Peak
6	2496.33	46.93	54.00	-7.07	15.30	3.83	27.80	0.00	171	108	HORIZONTAL Average

Item 3, 4 are the fundamental frequency at 2437 MHz.

##### Channel 11

	Freq	Level	Limit	Over	Read	CableAntenna	Preamp	A/Pos	T/Pos	Pol/Phase	Remark
	MHz	dBuV/m	dBuV/m	dB	dBuV	dB	dB/m	dB	cm	deg	
1	2461.13	108.56			76.93	3.79	27.84	0.00	200	249	HORIZONTAL Peak
2	2461.28	105.64			74.01	3.79	27.84	0.00	200	249	HORIZONTAL Average
3	2483.50	47.18	54.00	-6.82	15.54	3.82	27.82	0.00	200	249	HORIZONTAL Average
4	2484.08	60.11	74.00	-13.89	28.47	3.82	27.82	0.00	200	249	HORIZONTAL Peak

Item 1, 2 are the fundamental frequency at 2462 MHz.

<b>Temperature</b>	24°C	<b>Humidity</b>	55%
<b>Test Engineer</b>	JC Yang	<b>Configurations</b>	IEEE 802.11g CH 1, 6, 11 / Chain 1 + Chain 2
<b>Test Date</b>	Jul. 08, 2015		

**Channel 1**

	Freq	Level	Limit	Over	Read	CableAntenna	Preamp	A/Pos	T/Pos	Pol/Phase	Remark
	MHz	dBuV/m	dBuV/m	dB	dBuV	dB	dB/m	dB	cm	deg	
1	2389.71	73.09	74.00	-0.91	41.44	3.73	27.92	0.00	180	19 VERTICAL	Peak
2	2390.00	53.96	54.00	-0.04	22.31	3.73	27.92	0.00	180	19 VERTICAL	Average
3	2415.04	116.16			84.51	3.76	27.89	0.00	180	19 VERTICAL	Peak
4	2415.62	103.67			72.02	3.76	27.89	0.00	180	19 VERTICAL	Average

Item 3, 4 are the fundamental frequency at 2412 MHz.

**Channel 6**

	Freq	Level	Limit	Over	Read	CableAntenna	Preamp	A/Pos	T/Pos	Pol/Phase	Remark
	MHz	dBuV/m	dBuV/m	dB	dBuV	dB	dB/m	dB	cm	deg	
1	2388.84	73.56	74.00	-0.44	41.91	3.73	27.92	0.00	168	19 VERTICAL	Peak
2	2390.00	53.69	54.00	-0.31	22.04	3.73	27.92	0.00	168	19 VERTICAL	Average
3	2439.89	110.98			79.34	3.78	27.86	0.00	168	19 VERTICAL	Average
4	2439.89	121.38			89.74	3.78	27.86	0.00	168	19 VERTICAL	Peak
5	2483.79	52.34	54.00	-1.66	20.70	3.82	27.82	0.00	168	19 VERTICAL	Average
6	2483.79	70.90	74.00	-3.10	39.26	3.82	27.82	0.00	168	19 VERTICAL	Peak

Item 3, 4 are the fundamental frequency at 2437 MHz.

**Channel 11**

	Freq	Level	Limit	Over	Read	CableAntenna	Preamp	A/Pos	T/Pos	Pol/Phase	Remark
	MHz	dBuV/m	dBuV/m	dB	dBuV	dB	dB/m	dB	cm	deg	
1	2455.34	103.36			71.72	3.79	27.85	0.00	206	14 VERTICAL	Average
2	2455.34	114.89			83.25	3.79	27.85	0.00	206	14 VERTICAL	Peak
3	2483.50	53.96	54.00	-0.04	22.32	3.82	27.82	0.00	206	14 VERTICAL	Average
4	2484.22	73.14	74.00	-0.86	41.50	3.82	27.82	0.00	206	14 VERTICAL	Peak

Item 1, 2 are the fundamental frequency at 2462 MHz.

<b>Temperature</b>	24°C	<b>Humidity</b>	55%
<b>Test Engineer</b>	JC Yang	<b>Configurations</b>	IEEE 802.11n MCS0 HT20 CH 1, 6, 11 / Chain 1 + Chain 2
<b>Test Date</b>	Jul. 08, 2015		

**Channel 1**

	Freq	Level	Limit Line	Over Limit	Read Level	CableAntenna Loss	Antenna Factor	Preamp Factor	A/Pos	T/Pos	Pol/Phase	Remark
	MHz	dBuV/m	dBuV/m	dB	dBuV	dB	dB/m	dB	cm	deg		
1	2389.71	73.46	74.00	-0.54	41.81	3.73	27.92	0.00	176	17	VERTICAL	Peak
2	2389.86	53.62	54.00	-0.38	21.97	3.73	27.92	0.00	176	17	VERTICAL	Average
3	2405.34	113.06			81.42	3.74	27.90	0.00	176	17	VERTICAL	Peak
4	2406.50	102.67			71.03	3.74	27.90	0.00	176	17	VERTICAL	Average

Item 3, 4 are the fundamental frequency at 2412 MHz.

**Channel 6**

	Freq	Level	Limit Line	Over Limit	Read Level	CableAntenna Loss	Antenna Factor	Preamp Factor	A/Pos	T/Pos	Pol/Phase	Remark
	MHz	dBuV/m	dBuV/m	dB	dBuV	dB	dB/m	dB	cm	deg		
1	2389.42	70.07	74.00	-3.93	38.42	3.73	27.92	0.00	168	25	VERTICAL	Peak
2	2390.00	53.76	54.00	-0.24	22.11	3.73	27.92	0.00	168	25	VERTICAL	Average
3	2431.21	109.80			78.15	3.77	27.88	0.00	168	25	VERTICAL	Average
4	2444.24	119.60			87.96	3.78	27.86	0.00	168	25	VERTICAL	Peak
5	2483.50	52.25	54.00	-1.75	20.61	3.82	27.82	0.00	168	25	VERTICAL	Average
6	2483.50	71.01	74.00	-2.99	39.37	3.82	27.82	0.00	168	25	VERTICAL	Peak

Item 3, 4 are the fundamental frequency at 2437 MHz.

**Channel 11**

	Freq	Level	Limit Line	Over Limit	Read Level	CableAntenna Loss	Antenna Factor	Preamp Factor	A/Pos	T/Pos	Pol/Phase	Remark
	MHz	dBuV/m	dBuV/m	dB	dBuV	dB	dB/m	dB	cm	deg		
1	2463.59	101.18			69.54	3.80	27.84	0.00	190	113	VERTICAL	Average
2	2463.88	111.25			79.61	3.80	27.84	0.00	190	113	VERTICAL	Peak
3	2483.50	53.95	54.00	-0.05	22.31	3.82	27.82	0.00	190	113	VERTICAL	Average
4	2483.50	73.21	74.00	-0.79	41.57	3.82	27.82	0.00	190	113	VERTICAL	Peak

Item 1, 2 are the fundamental frequency at 2462 MHz.

<b>Temperature</b>	24°C	<b>Humidity</b>	55%
<b>Test Engineer</b>	JC Yang	<b>Configurations</b>	IEEE 802.11n MCS0 HT40 CH 3, 6, 9 / Chain 1 + Chain 2
<b>Test Date</b>	Jul. 08, 2015		

**Channel 3**

	Freq	Level	Limit Line	Over Limit	Read Level	CableAntenna Loss	Preamp Factor	A/Pos	T/Pos	Pol/Phase	Remark
	MHz	dBuV/m	dBuV/m	dB	dBuV	dB	dB/m	dB	cm	deg	
1	2388.55	70.84	74.00	-3.16	39.19	3.73	27.92	0.00	168	15 VERTICAL	Peak
2	2390.00	53.78	54.00	-0.22	22.13	3.73	27.92	0.00	168	15 VERTICAL	Average
3	2408.69	96.72			65.07	3.75	27.90	0.00	168	15 VERTICAL	Average
4	2437.92	108.18			76.54	3.77	27.87	0.00	168	15 VERTICAL	Peak

Item 3, 4 are the fundamental frequency at 2422 MHz.

**Channel 6**

	Freq	Level	Limit Line	Over Limit	Read Level	CableAntenna Loss	Preamp Factor	A/Pos	T/Pos	Pol/Phase	Remark
	MHz	dBuV/m	dBuV/m	dB	dBuV	dB	dB/m	dB	cm	deg	
1	2389.71	70.50	74.00	-3.50	38.85	3.73	27.92	0.00	155	11 VERTICAL	Peak
2	2390.00	53.81	54.00	-0.19	22.16	3.73	27.92	0.00	155	11 VERTICAL	Average
3	2422.53	100.70			69.05	3.76	27.89	0.00	155	11 VERTICAL	Average
4	2452.63	110.83			79.20	3.78	27.85	0.00	155	11 VERTICAL	Peak
5	2483.50	53.46	54.00	-0.54	21.82	3.82	27.82	0.00	155	11 VERTICAL	Average
6	2483.50	70.28	74.00	-3.72	38.64	3.82	27.82	0.00	155	11 VERTICAL	Peak

Item 3, 4 are the fundamental frequency at 2437 MHz.

**Channel 9**

	Freq	Level	Limit Line	Over Limit	Read Level	CableAntenna Loss	Preamp Factor	A/Pos	T/Pos	Pol/Phase	Remark
	MHz	dBuV/m	dBuV/m	dB	dBuV	dB	dB/m	dB	cm	deg	
1	2436.08	96.83			65.19	3.77	27.87	0.00	173	24 VERTICAL	Average
2	2436.37	107.02			75.38	3.77	27.87	0.00	173	24 VERTICAL	Peak
3	2483.50	52.96	54.00	-1.04	21.32	3.82	27.82	0.00	173	24 VERTICAL	Average
4	2483.50	73.86	74.00	-0.14	42.22	3.82	27.82	0.00	173	24 VERTICAL	Peak

Item 1, 2 are the fundamental frequency at 2452 MHz.

Note:

Emission level (dBuV/m) = 20 log Emission level (uV/m).

Corrected Reading: Antenna Factor + Cable Loss + Read Level - Preamp Factor = Level.

For Emission not in Restricted Band

Plot on Configuration IEEE 802.11b / Reference Level

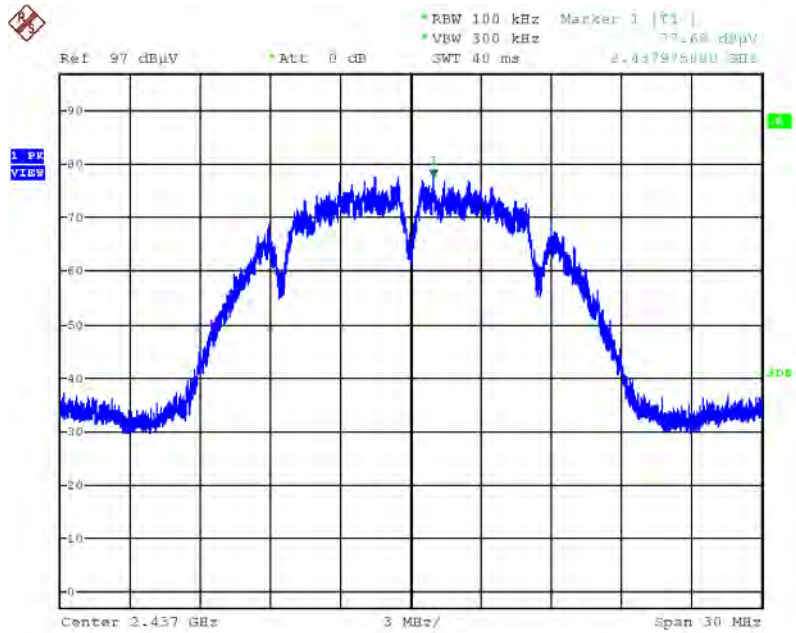

Date: 9.JUL.2015 22:56:27

Plot on Configuration IEEE 802.11b / CH 1 / 30MHz~2400MHz (down 30dBc)

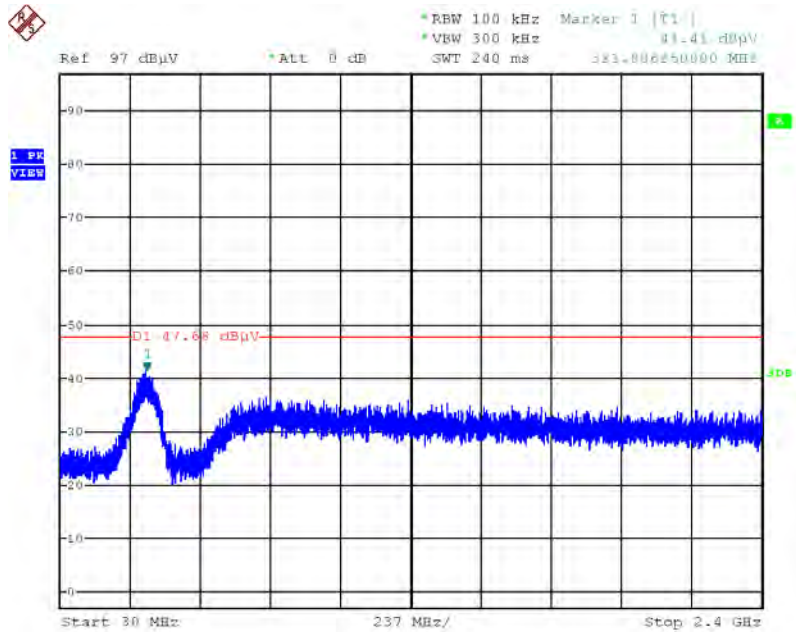

Date: 9.JUL.2015 22:57:02

Plot on Configuration IEEE 802.11b / CH 1 / 2500MHz~26500MHz (down 30dBc)

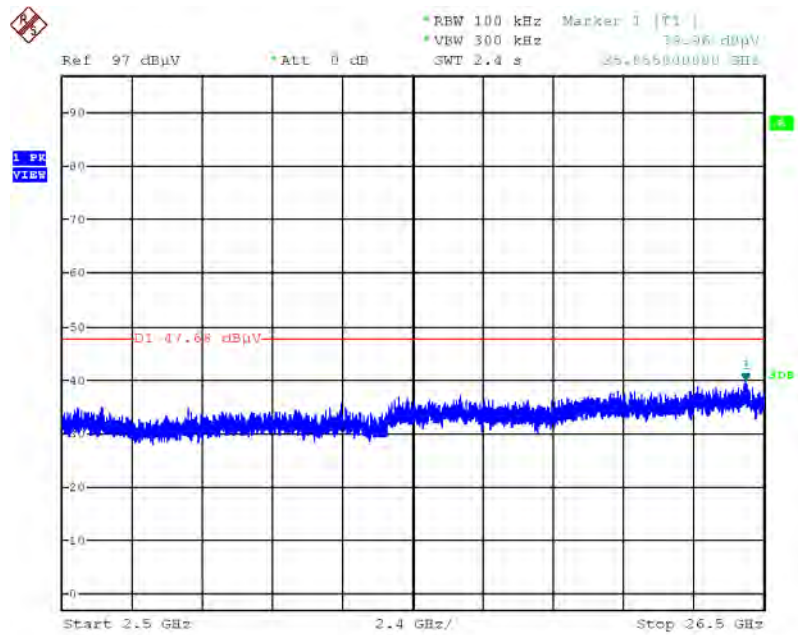

Date: 9.JUL.2015 22:57:33

Plot on Configuration IEEE 802.11b / CH 11 / 30MHz~2400MHz (down 30dBc)

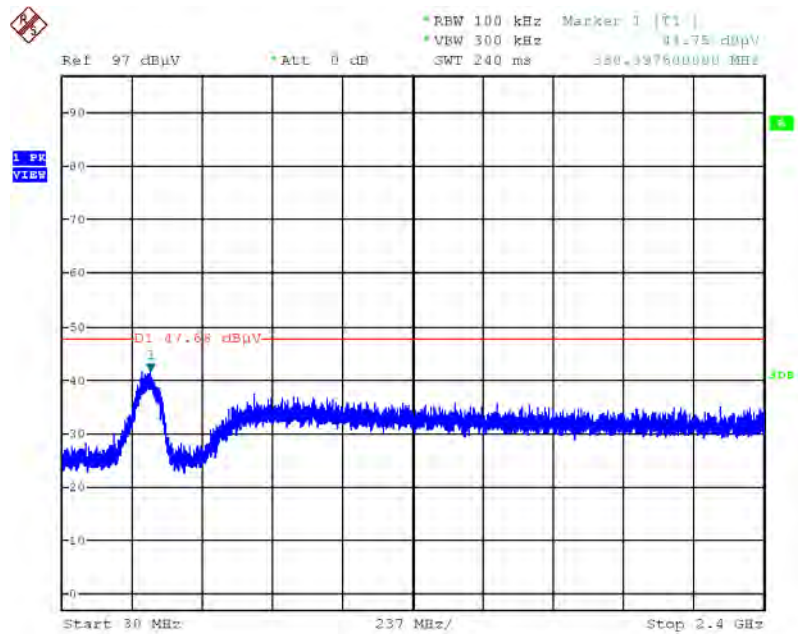

Date: 9.JUL.2015 22:58:14

Plot on Configuration IEEE 802.11b / CH 11 / 2500MHz~26500MHz (down 30dBc)

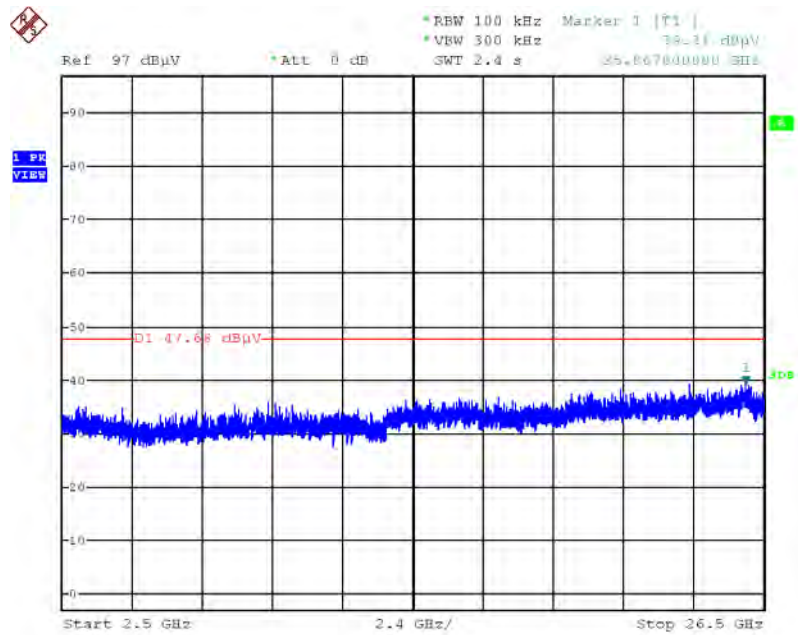

Date: 9.JUL.2015 22:58:35



Plot on Configuration IEEE 802.11g / Reference Level

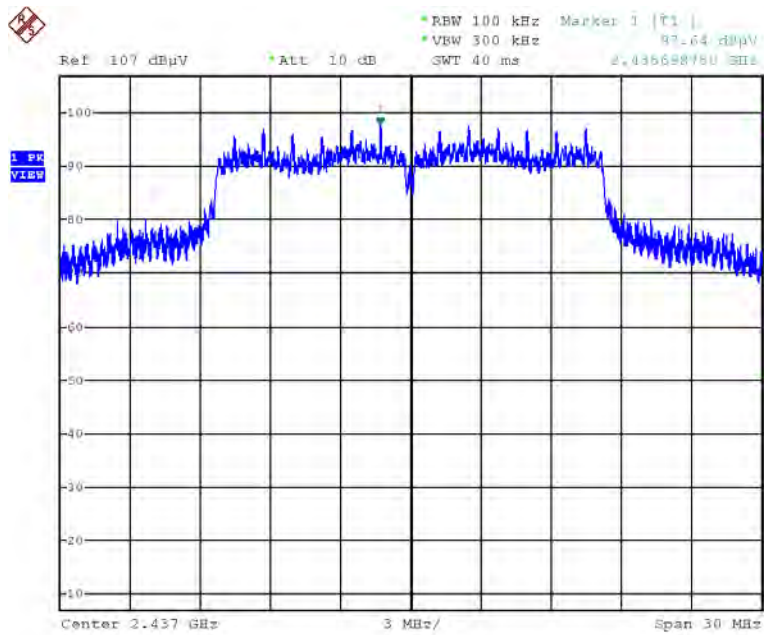

Date: 9.JUL.2015 22:53:05

Plot on Configuration IEEE 802.11g / CH 1 / 30MHz~2400MHz (down 30dBc)

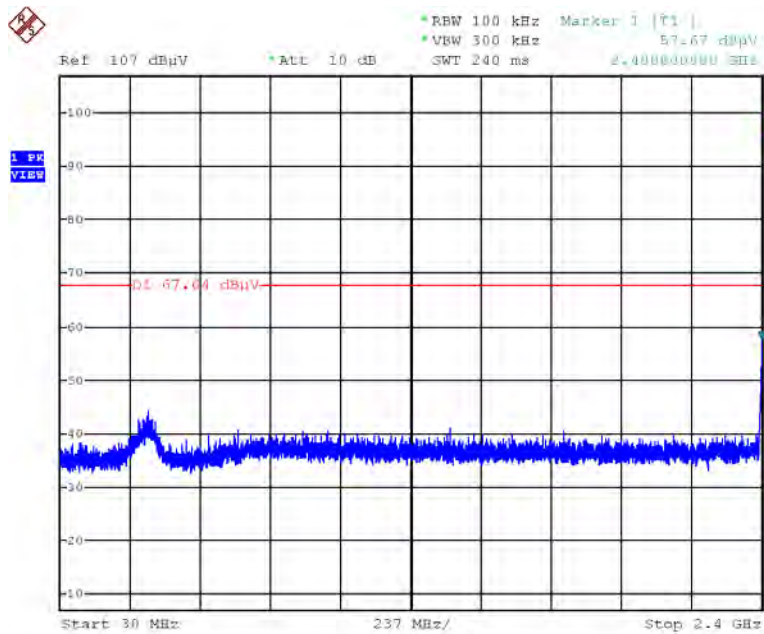

Date: 9.JUL.2015 22:53:56

Plot on Configuration IEEE 802.11g / CH 1 / 2500MHz~2650MHz (down 30dBc)

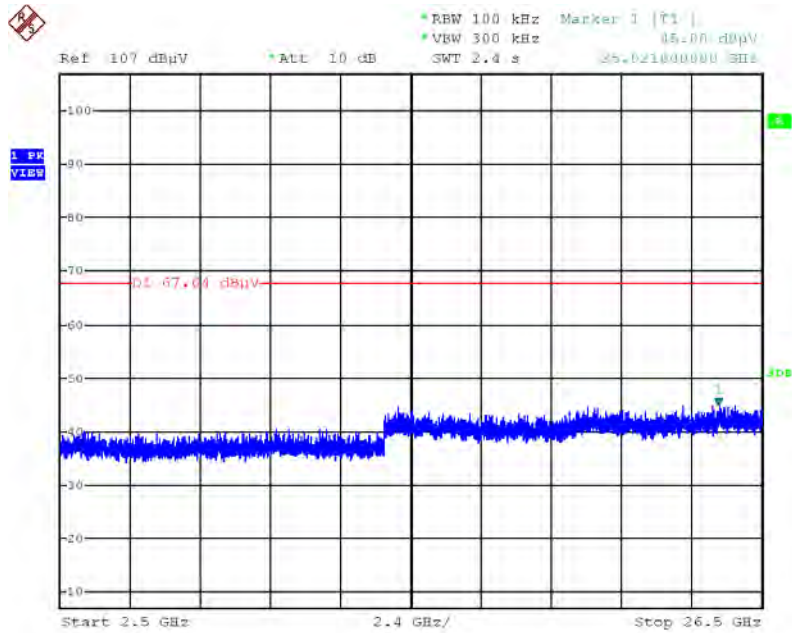

Date: 9.JUL.2015 22:54:21

Plot on Configuration IEEE 802.11g / CH 11 / 30MHz~2400MHz (down 30dBc)

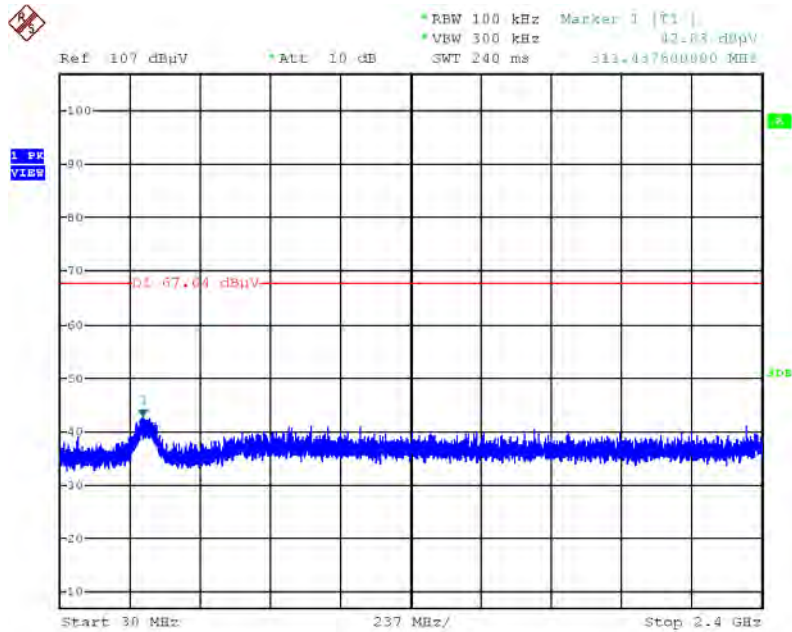

Date: 9.JUL.2015 22:54:56

Plot on Configuration IEEE 802.11g / CH 11 / 2500MHz~26500MHz (down 30dBc)

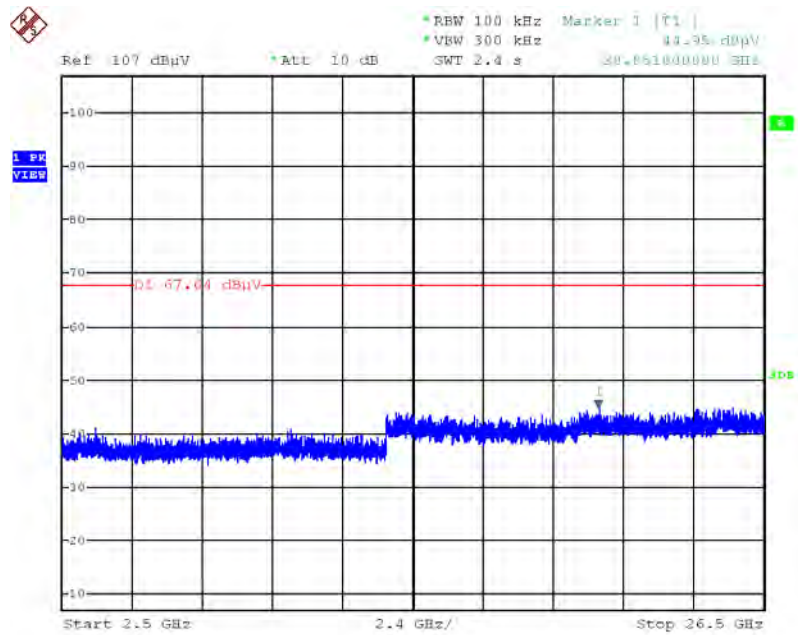

Date: 9.JUL.2015 22:55:18

Plot on Configuration IEEE 802.11n MCS0 HT20 / Reference Level

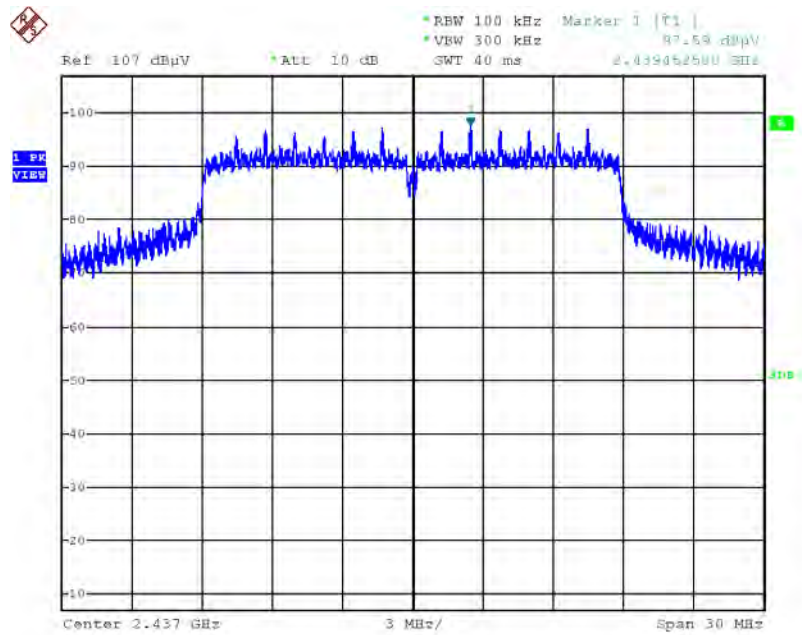

Date: 9.JUL.2015 22:49:15

Plot on Configuration IEEE 802.11n MCS0 HT20 / CH 1 / 30MHz~2400MHz (down 30dBc)

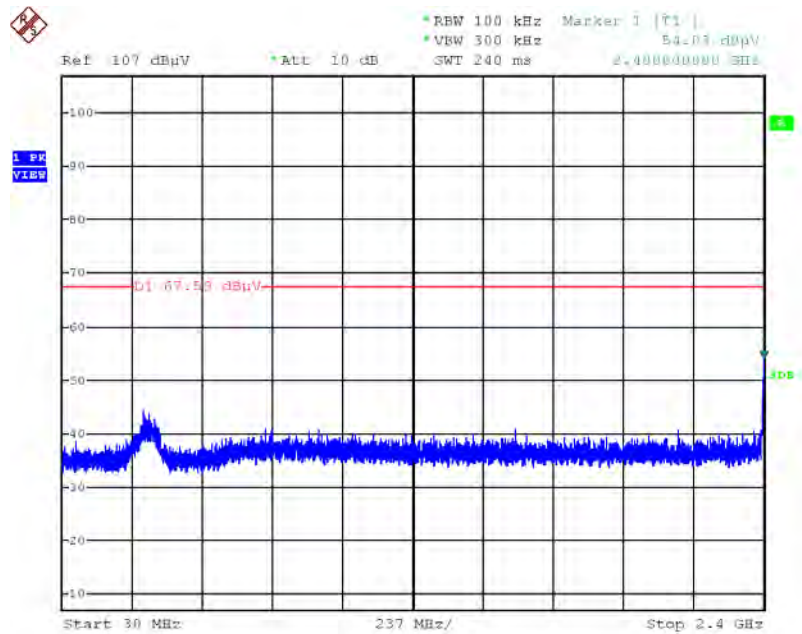

Date: 9.JUL.2015 22:50:25

Plot on Configuration IEEE 802.11n MCS0 HT20 / CH 1 / 2500MHz~26500MHz (down 30dBc)

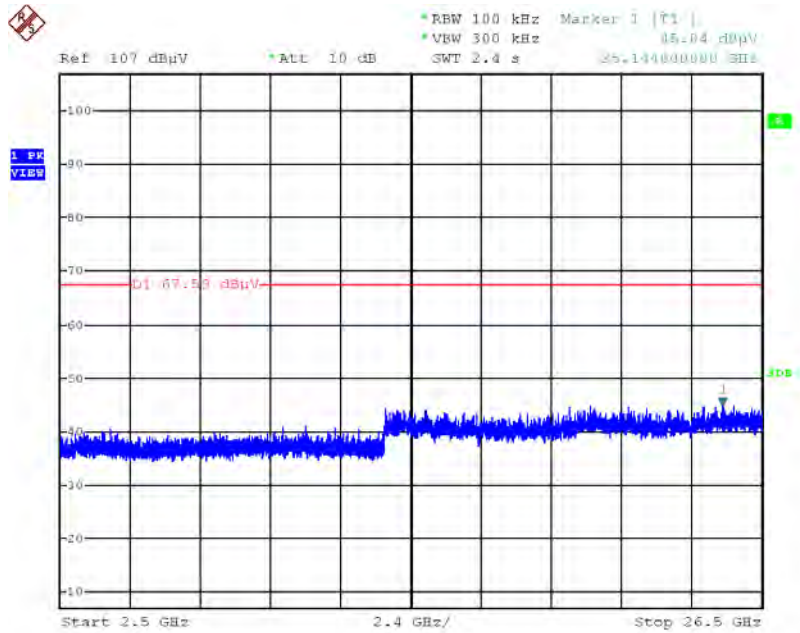

Date: 9.JUL.2015 22:50:49

Plot on Configuration IEEE 802.11n MCS0 HT20 / CH 11 / 30MHz~2400MHz (down 30dBc)

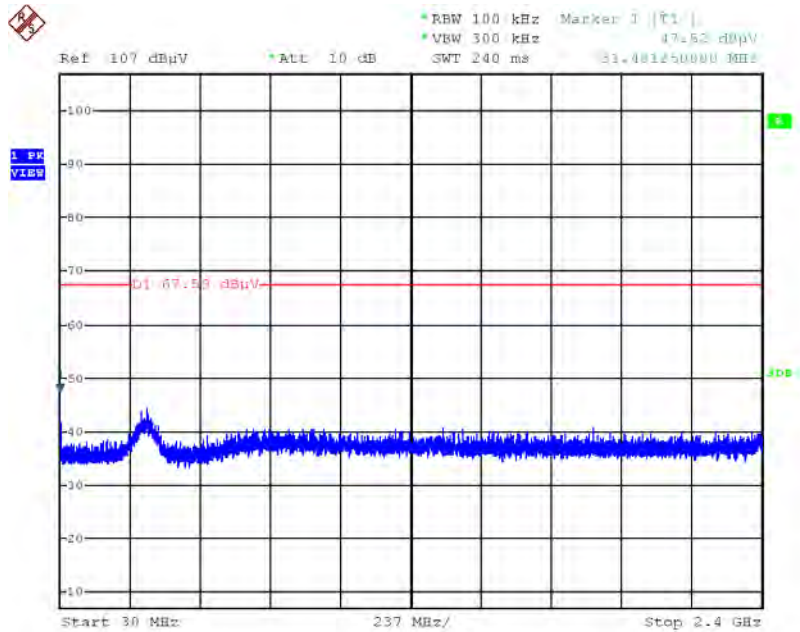

Date: 9.JUL.2015 22:51:40

Plot on Configuration IEEE 802.11n MCS0 HT20 / CH 11 / 2500MHz~26500MHz (down 30dBc)

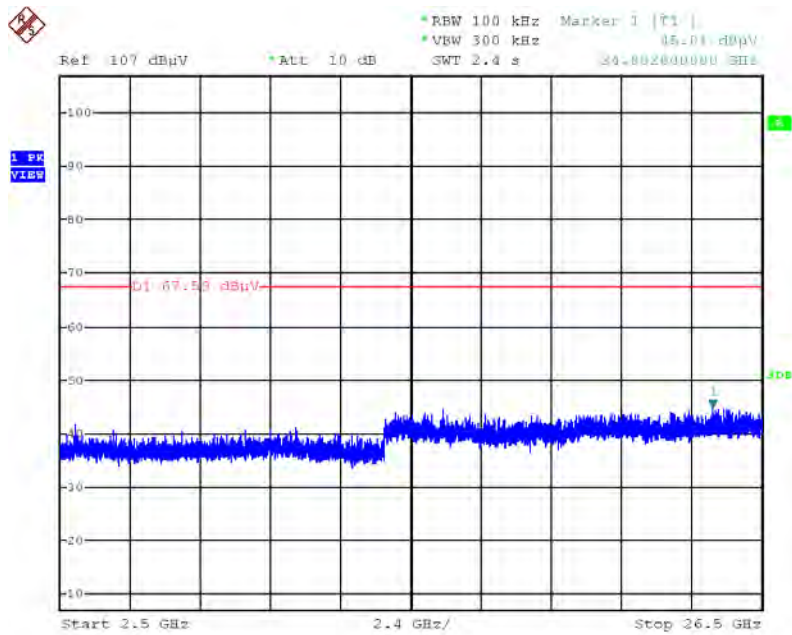

Date: 9.JUL.2015 22:52:12

Plot on Configuration IEEE 802.11n MCS0 HT40 / Reference Level

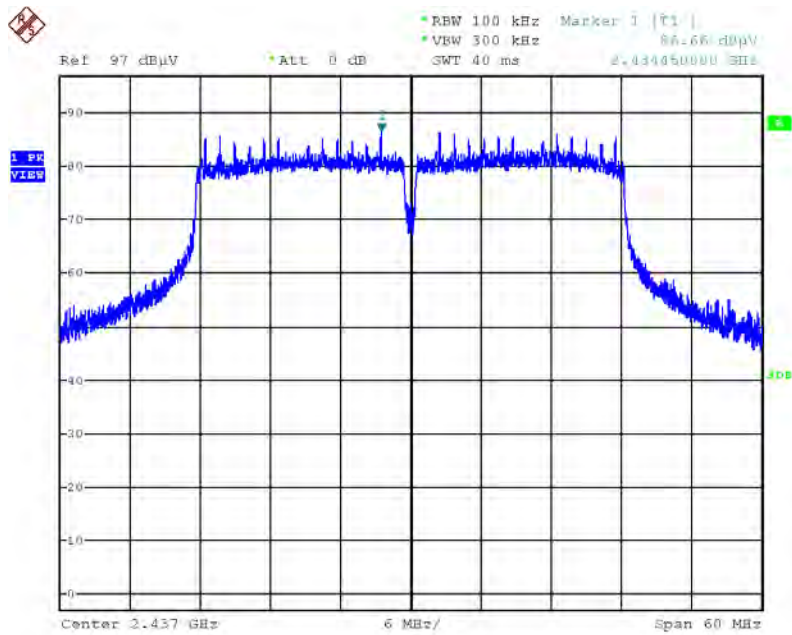

Date: 9.JUL.2015 22:44:37

Plot on Configuration IEEE 802.11n MCS0 HT40 / CH 3 / 30MHz~2400MHz (down 30dBc)

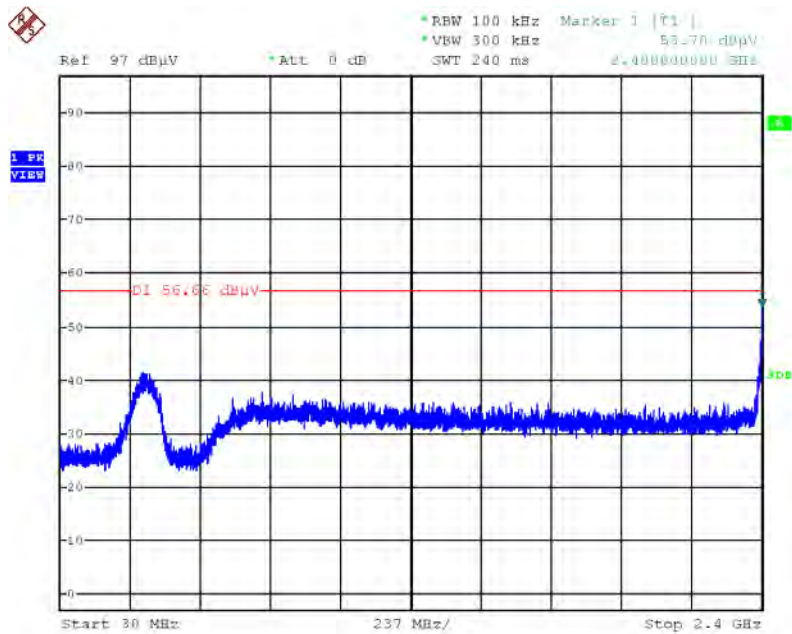

Date: 9.JUL.2015 22:46:06

Plot on Configuration IEEE 802.11n MCS0 HT40 / CH 3 / 2500MHz~26500MHz (down 30dBc)

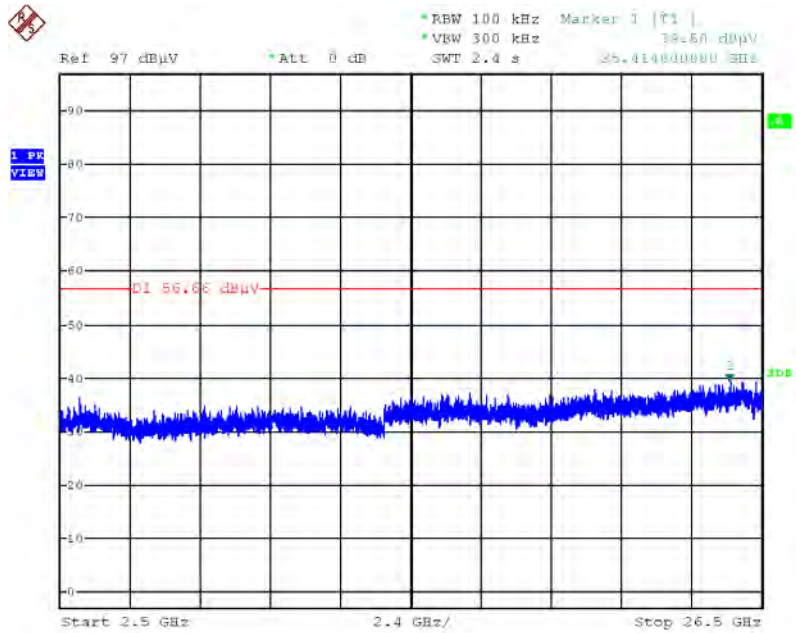

Date: 9.JUL.2015 22:46:34

Plot on Configuration IEEE 802.11n MCS0 HT40 / CH 9 / 30MHz~2400MHz (down 30dBc)

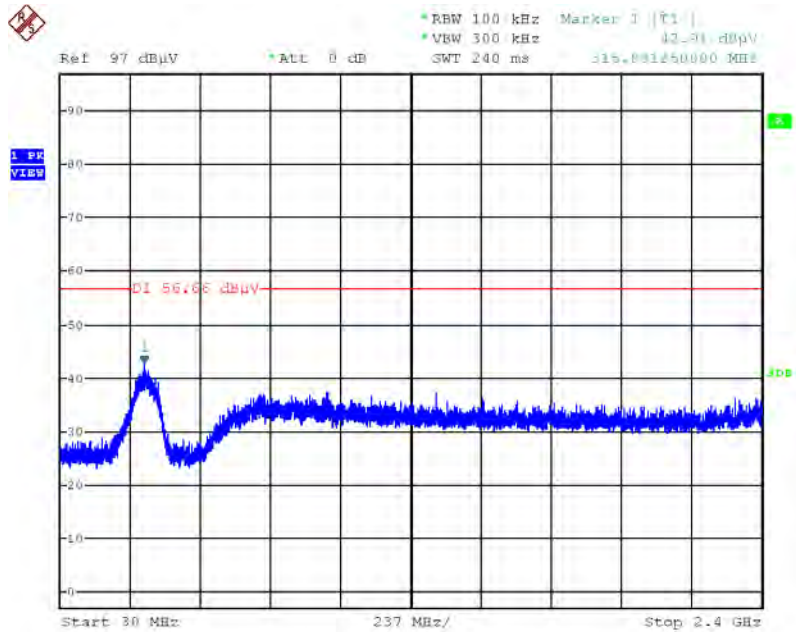

Date: 9.JUL.2015 22:47:29



Plot on Configuration IEEE 802.11n MCS0 HT40 / CH 9 / 2500MHz~26500MHz (down 30dBc)

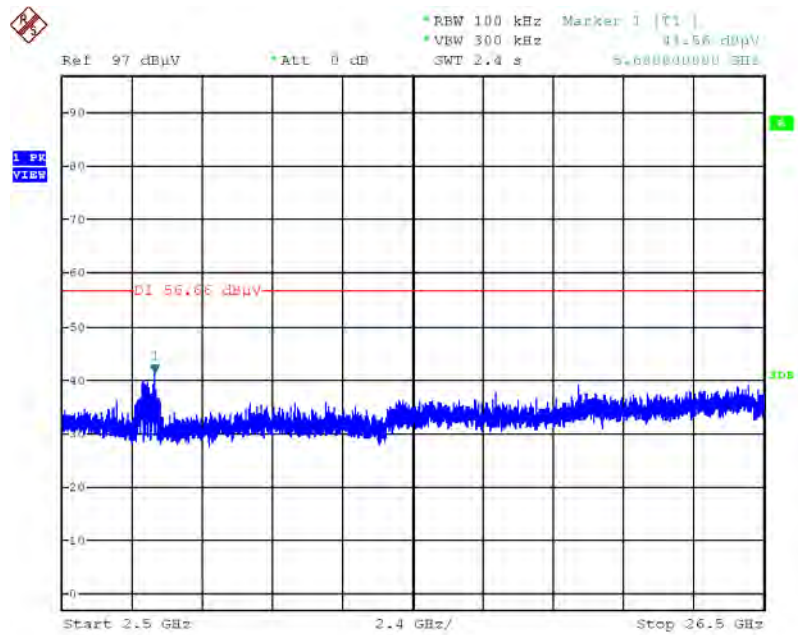

Date: 9.JUL.2015 22:47:52

## 4.7. Antenna Requirements

### 4.7.1. Limit

Except for special regulations, the Low-power Radio-frequency Devices must not be equipped with any jacket for installing an antenna with extension cable. An intentional radiator shall be designed to ensure that no antenna other than that furnished by the responsible party shall be used with the device. The use of a permanently attached antenna or of an antenna that uses a unique coupling to the intentional radiator shall be considered sufficient to comply with the provisions of this Section. The manufacturer may design the unit so that the user can replace a broken antenna, but the use of a standard antenna jack or electrical connector is prohibited. Further, this requirement does not apply to intentional radiators that must be professionally installed.

### 4.7.2. Antenna Connector Construction

Please refer to section 3.3 in this test report; antenna connector complied with the requirements.

## 5. LIST OF MEASURING EQUIPMENTS

Instrument	Manufacturer	Model No.	Serial No.	Characteristics	Calibration Date	Remark
EMI Test Receiver	R&S	ESCS 30	100355	9kHz ~ 2.75GHz	Apr. 22, 2015	Conduction (CO01-CB)
LISN	F.C.C.	FCC-LISN-50-16-2	04083	150kHz ~ 100MHz	Dec. 02, 2014	Conduction (CO01-CB)
LISN	Schwarzbeck	NSLK 8127	8127647	9kHz ~ 30MHz	Dec. 02, 2014	Conduction (CO01-CB)
COND Cable	Woken	Cable	01	150kHz ~ 30MHz	Dec. 03, 2014	Conduction (CO01-CB)
Software	Audix	E3	5.410e	-	N.C.R.	Conduction (CO01-CB)
BILOG ANTENNA	Schaffner	CBL6112D	22021	20MHz ~ 2GHz	May 06, 2015	Radiation (O3CH01-CB)
Loop Antenna	Teseq	HLA 6120	24155	9kHz - 30 MHz	Mar. 12, 2015	Radiation (O3CH01-CB)
Horn Antenna	EMCO	3115	00075790	750MHz ~ 18GHz	Oct. 28, 2014	Radiation (O3CH01-CB)
Horn Antenna	Schwarzbeck	BBHA 9170	BBHA9170252	15GHz ~ 40GHz	Aug. 22, 2014	Radiation (O3CH01-CB)
Pre-Amplifier	Agilent	8447D	2944A10991	0.1MHz ~ 1.3GHz	Feb. 24, 2015	Radiation (O3CH01-CB)
Pre-Amplifier	Agilent	8449B	3008A02310	1GHz ~ 26.5GHz	Jan. 12, 2015	Radiation (O3CH01-CB)
Pre-Amplifier	WM	TF-130N-R1	923365	26GHz ~ 40GHz	Nov. 25, 2014	Radiation (O3CH01-CB)
Spectrum Analyzer	R&S	FSP40	100056	9kHz ~ 40GHz	Nov. 06, 2014	Radiation (O3CH01-CB)
EMI Receiver	Agilent	N9038A	MY52260123	9kHz ~ 8.4GHz	Jan. 21, 2015	Radiation (O3CH01-CB)
RF Cable-low	Woken	Low Cable-1	N/A	30 MHz ~ 1 GHz	Nov. 15, 2014	Radiation (O3CH01-CB)
RF Cable-high	Woken	High Cable-40G-1	N/A	1 GHz ~ 40 GHz	Nov. 15, 2014	Radiation (O3CH01-CB)
RF Cable-high	Woken	High Cable-40G-2	N/A	1 GHz ~ 40 GHz	Nov. 15, 2014	Radiation (O3CH01-CB)
Spectrum analyzer	R&S	FSV40	100979	9kHz~40GHz	Dec. 12, 2014	Conducted (TH01-CB)
Temp. and Humidity Chamber	Ten Billion	TTH-D3SP	TBN-931011	-30~100 degree	Jun. 02, 2015	Conducted (TH01-CB)
RF Cable-high	Woken	RG402	High Cable-7	1 GHz – 26.5 GHz	Nov. 15, 2014	Conducted (TH01-CB)
RF Cable-high	Woken	RG402	High Cable-8	1 GHz – 26.5 GHz	Nov. 15, 2014	Conducted (TH01-CB)
RF Cable-high	Woken	RG402	High Cable-9	1 GHz – 26.5 GHz	Nov. 15, 2014	Conducted (TH01-CB)
RF Cable-high	Woken	RG402	High Cable-10	1 GHz – 26.5 GHz	Nov. 15, 2014	Conducted (TH01-CB)
RF Cable-high	Woken	RG402	High Cable-6	1 GHz – 26.5 GHz	Nov. 15, 2014	Conducted (TH01-CB)
Power Sensor	Agilent	U2021XA	MY53410001	50MHz~18GHz	Nov. 03, 2014	Conducted (TH01-CB)

Note: Calibration Interval of instruments listed above is one year.

N.C.R. means Non-Calibration required.

## 6. MEASUREMENT UNCERTAINTY

Test Items	Uncertainty	Remark
Conducted Emission (150kHz ~ 30MHz)	2.4 dB	Confidence levels of 95%
Radiated Emission (30MHz ~ 1,000MHz)	3.6 dB	Confidence levels of 95%
Radiated Emission (1GHz ~ 18GHz)	3.7 dB	Confidence levels of 95%
Radiated Emission (18GHz ~ 40GHz)	3.5 dB	Confidence levels of 95%
Conducted Emission	1.7 dB	Confidence levels of 95%