

FCC PART 90

TEST REPORT

For

Hytera Communications Co., Ltd.

HYT Tower, Hi-Tech Industrial Park North, Nanshan District, Shenzhen, China

FCC ID: YAMRD98XSU5

Report Type: Original Report	Product Type: Digital Base Station Repeater
Test Engineer: Candy Li	<i>Candy Li</i>
Report Number: RSZ131104004-00A	
Report Date: 2014-04-18	
Reviewed By: Jimmy Xiao RF Engineer	<i>Jimmy Xiao</i>
Prepared By: Bay Area Compliance Laboratories Corp. (Shenzhen) 6/F, the 3rd Phase of WanLi Industrial Building, ShiHua Road, FuTian Free Trade Zone Shenzhen, Guangdong, China Tel: +86-755-33320018 Fax: +86-755-33320008 www.baclcorp.com.cn	

Note: This test report is prepared for the customer shown above and for the equipment described herein. It may not be duplicated or used in part without prior written consent from Bay Area Compliance Laboratories Corp.

TABLE OF CONTENTS

GENERAL INFORMATION.....4

 PRODUCT DESCRIPTION FOR EQUIPMENT UNDER TEST (EUT)4

 OBJECTIVE4

 RELATED SUBMITTAL(S)/GRANT(S).....4

 TEST METHODOLOGY4

 TEST FACILITY5

SYSTEM TEST CONFIGURATION.....6

 DESCRIPTION OF TEST CONFIGURATION6

 EQUIPMENT MODIFICATIONS6

 SUPPORT EQUIPMENT LIST AND DETAILS6

 EXTERNAL I/O CABLE.....6

 BLOCK DIAGRAM OF TEST SETUP6

SUMMARY OF TEST RESULTS7

FCC§1.1307 (b) (1) & §2.1091- MAXIMUM PERMISSIBLE EXPOSURE (MPE)8

 APPLICABLE STANDARD8

 RESULT8

FCC §2.1046 & §90.205- RF OUTPUT POWER.....9

 APPLICABLE STANDARD9

 TEST PROCEDURE9

 TEST EQUIPMENT LIST AND DETAILS.....9

 TEST DATA9

FCC §2.1047 & §90.207 - MODULATION CHARACTERISTIC11

 APPLICABLE STANDARD11

 TEST EQUIPMENT LIST AND DETAILS.....11

 TEST PROCEDURE11

 TEST DATA11

FCC §2.1049 & §90.209 & §90.210 – OCCUPIED BANDWIDTH & EMISSION MASK.....21

 APPLICABLE STANDARD21

 TEST EQUIPMENT LIST AND DETAILS.....21

 TEST PROCEDURE21

 TEST DATA22

FCC §2.1051 & §90.210 - SPURIOUS EMISSIONS AT ANTENNA TERMINALS39

 APPLICABLE STANDARD39

 TEST EQUIPMENT LIST AND DETAILS.....39

 TEST PROCEDURE39

 TEST DATA39

FCC §2.1053 & §90.210 - RADIATED SPURIOUS EMISSIONS48

 APPLICABLE STANDARD48

 TEST EQUIPMENT LIST AND DETAILS.....48

 TEST PROCEDURE48

 TEST DATA49

FCC §2.1055 & §90.213- FREQUENCY STABILITY.....52

 APPLICABLE STANDARD52

TEST EQUIPMENT LIST AND DETAILS.....52
TEST PROCEDURE52
TEST DATA52
PRODUCT SIMILARITY DECLARATION LETTER.....57

GENERAL INFORMATION

Product Description for Equipment under Test (EUT)

The *Hytera Communications Co., Ltd.*'s product, model number: *RD982S U(5)* (FCC ID: *YAMRD98XSU5*) or the "EUT" in this report was a *Digital Base Station Repeater*, which was measured approximately: 366 mm (L) x 483 mm (W) x 88 mm (H), rated with input voltage: DC 13.6V.

Note: The product, series model RD980S U(5), RD982S U(5), RD985S U(5), RD986S U(5) and RD988S U(5) are electrically identical, they are just different in model number due to market purposes, which was explained in the attached declaration letter. And the model RD982S U(5) was selected for fully testing.

** All measurement and test data in this report was gathered from production sample serial number: 1311006 (Assigned by BACL, Shenzhen). The EUT supplied by the applicant was received on 2013-11-04.*

Objective

This test report is prepared on behalf of *Hytera Communications Co., Ltd.* in accordance with Part 2, and Part 90 of the Federal Communication Commissions rules.

Related Submittal(s)/Grant(s)

No related submittal.

Test Methodology

All tests and measurements indicated in this document were performed in accordance with the Code of federal Regulations Title 47 Part 2, Sub-part J as well as the following individual parts:

Part 90 – Private Land Mobile Radio Service

Applicable Standards: TIA 603-D and ANSI 63.4-2009.

All emissions measurement was performed and Bay Area Compliance Laboratories Corp. (Shenzhen). The radiated testing was performed at an antenna-to-EUT distance of 3 meters.

Measurement uncertainty with radiated emission is 5.91 dB for 30MHz-1GHz and 4.92 dB for above 1GHz, 1.95dB for conducted measurement.

Test Facility

The test site used by Bay Area Compliance Laboratories Corp. (Shenzhen) to collect test data is located on the 6/F, the 3rd Phase of WanLi Industrial Building, ShiHua Road, FuTian Free Trade Zone Shenzhen, Guangdong, China.

Test site at Bay Area Compliance Laboratories Corp. (Shenzhen) has been fully described in reports submitted to the Federal Communication Commission (FCC). The details of these reports have been found to be in compliance with the requirements of Section 2.948 of the FCC Rules on December 06, 2010. The facility also complies with the radiated and AC line conducted test site criteria set forth in ANSI C63.4-2009.

The Federal Communications Commission has the reports on file and is listed under FCC Registration No.: 382179. The test site has been approved by the FCC for public use and is listed in the FCC Public Access Link (PAL) database.

SYSTEM TEST CONFIGURATION

Description of Test Configuration

The system was configured for testing in a test mode which has been done in the factory.

Equipment Modifications

No modification was made to the EUT tested.

Support Equipment List and Details

Manufacturer	Description	Model	Serial Number
Mean Well	DC Power	SP-320-13.5	N/A

External I/O Cable

Cable Description	Length (m)	From Port	To
Unshielded Detectable AC Power Cable	2.0	AC Mains	DC Power
Unshielded Detectable DC Power Cable	2.5	DC Power	EUT

Block Diagram of Test Setup

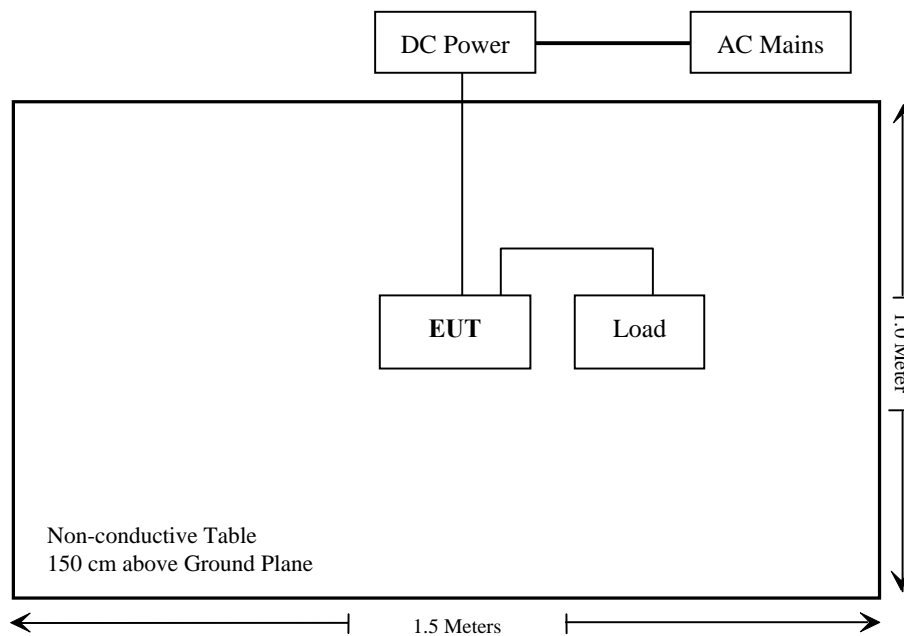

SUMMARY OF TEST RESULTS

FCC Rules	Description of Test	Results
§1.1307 (b)(1), §2.1091	Maximum Permissible Exposure (MPE)	Compliance
§2.1046; §90.205	RF Output Power	Compliance
§2.1047; §90.207	Modulation Characteristic	Compliance
§2.1049; §90.209; §90.210	Occupied Bandwidth & Emission Mask	Compliance
§2.1051; §90.210	Spurious Emission at Antenna Terminal	Compliance
§2.1053; §90.210	Spurious Radiated Emissions	Compliance
§2.1055; §90.213	Frequency Stability	Compliance
§90.214	Transient Frequency Behavior	Not Applicable

FCC§1.1307 (b) (1) & §2.1091- MAXIMUM PERMISSIBLE EXPOSURE (MPE)

Applicable Standard

According to subpart 1.1307 (b)(1), 2.1091 systems operating under the provisions of this section shall be operated in a manner that ensures the public is not exposed to RF energy level in excess of the communication guidelines.

(A) Limits for Occupational/Controlled Exposure

Frequency Range (MHz)	Electric Field Strength (E) (V/m)	Magnetic Field Strength (H) (A/m)	Power Density (S) (mW/cm ²)	Averaging Time E ² , H ² or S (minutes)
0.3-3.0	614	1.63	(100)*	6
3.0-30	1842/f	4.89/f	(900/f ²)*	6
30-300	61.4	0.163	1.0	6
300-1500	--	--	f/300	6
1500-100,000	--	--	5	6

f = frequency in MHz

* = Plane-wave equivalent power density

Result

Calculated Formulary:

Predication of MPE limit at a given distance

$$S = \frac{PG}{4\pi R^2}$$

S = power density (in appropriate units, e.g. mW/cm²)

P = power input to the antenna (in appropriate units, e.g., mW).

G = power gain of the antenna in the direction of interest relative to an isotropic radiator, the power gain factor, is normally numeric gain.

R = distance to the center of radiation of the antenna (appropriate units, e.g., cm)

Frequency (MHz)	Antenna Gain		Conducted Power		Evaluation Distance (cm)	Power Density (mW/cm ²)	MPE Limit (mW/cm ²)
	(dBi)	(numeric)	(dBm)	(mW)			
851.0125	9	7.94	45.74	37497.30	350	0.19	2.84

Radiation Exposure Statement:

To comply with FCC RF exposure requirements, a minimum separation distance of 350cm is required between the antenna and all public persons.

Result: Compliance

FCC §2.1046 & §90.205- RF OUTPUT POWER

Applicable Standard

FCC §2.1046 and §90.205

Test Procedure

Conducted RF Output Power:

The RF output of the transmitter was connected to the input of the spectrum analyzer through sufficient attenuation.

Spectrum Analyzer Setting:

R B/W	Video B/W
100 kHz	300 kHz

Test Equipment List and Details

Manufacturer	Description	Model	Serial Number	Calibration Date	Calibration Due Date
Rohde & Schwarz	Signal Analyzer	FSIQ26	8386001028	2013-11-12	2014-11-12

* **Statement of Traceability:** Bay Area Compliance Laboratories Corp. (Shenzhen) attests that all calibrations have been performed in accordance to requirements, traceable to National Primary Standards and International System of Units (SI).

Test Data

Environmental Conditions

Temperature:	25 °C
Relative Humidity:	55 %
ATM Pressure:	101.0 kPa

The testing was performed by Candy Li on 2014-04-11.

Test Mode: Transmitting

Test Result: Compliance. Please refer to following table.

Modulation	Frequency Spacing (kHz)	Frequency (MHz)	Power level	Conducted Output Power (dBm)	Conducted Output Power (W)	Note		
Analog	12.5	851.0125	High	45.74	37.50	-		
			Low	37.13	5.16			
		868.9875	High	45.74	37.50	-		
			Low	37.27	5.33			
		935.0125	High	45.01	31.70	-		
			Low	37.21	5.26			
		939.9875	High	45.03	31.84	-		
			Low	37.17	5.21			
		940.9875	High	45.13	32.58	Not for FCC review		
			Low	37.22	5.27			
		Digital	12.5	851.0125	High	45.74	37.50	-
					Low	37.15	5.19	
868.9875	High			45.74	37.50	-		
	Low			37.29	5.36			
935.0125	High			45.00	31.62	-		
	Low			37.21	5.26			
939.9875	High			45.02	31.77	-		
	Low			37.16	5.20			
940.9875	High			45.12	32.51	Not for FCC review		
	Low			37.23	5.28			

Note: The manufacturer's rated power is below:
 851-870MHz: 35W=45.44dBm High power
 5W= 36.99dBm Low power
 935-941MHz: 30W=44.77dBm High power
 5W= 36.99dBm Low power

FCC §2.1047 & §90.207 - MODULATION CHARACTERISTIC

Applicable Standard

FCC§2.1047, §90.207:

- (a) Equipment which utilizes voice modulated communication shall show the frequency response of the audio modulating circuit over a range of 100 to 5000 Hz. for equipment which is required to have a low pass filter, the frequency response of the filter, or all of the circuitry installed between the modulation limited and the modulated stage shall be supplied.
- (b) Equipment which employs modulation limiting, a curve showing the percentage of modulation versus the modulation input voltage shall be supplied.

Test Equipment List and Details

Manufacturer	Description	Model No.	Serial No.	Calibration Date	Calibration Due Date
HP	RF Communication Test Set	8920A	3325U00859	2013-05-07	2014-05-07
LEADER	MILLIVOLTMETER	LMV-181A	6041126	2013-05-13	2014-05-13

* **Statement of Traceability:** Bay Area Compliance Laboratories Corp. (Shenzhen) attests that all calibrations have been performed in accordance to requirements, traceable to National Primary Standards and International System of Units (SI).

Test Procedure

Test Method: TIA/EIA-603 2.2.3

Test Data

Environmental Conditions

Temperature:	25 °C
Relative Humidity:	55 %
ATM Pressure:	101.0 kPa

The testing was performed by Candy Li on 2014-04-11.

Test Mode: Transmitting

Result: Compliance.

Analog Modulation:

MODULATION LIMITING

Carrier Frequency: 851.0125 MHz, Channel Separation=12.5 kHz

Audio Input Level [dB]	Frequency Deviation (kHz)			Limit [kHz]
	@ 300 Hz	@ 1kHz	@ 3 kHz	
20.0	1.772	2.137	1.435	4.0
15.0	1.571	2.151	1.439	4.0
10.0	1.536	2.146	1.438	4.0
5.0	0.890	2.150	1.444	4.0
0.0	0.495	2.148	1.435	4.0
-5.0	0.309	1.246	1.430	4.0
-10.0	0.194	0.725	1.405	4.0
-15.0	0.136	0.437	0.820	4.0
-20.0	0.089	0.264	0.486	4.0

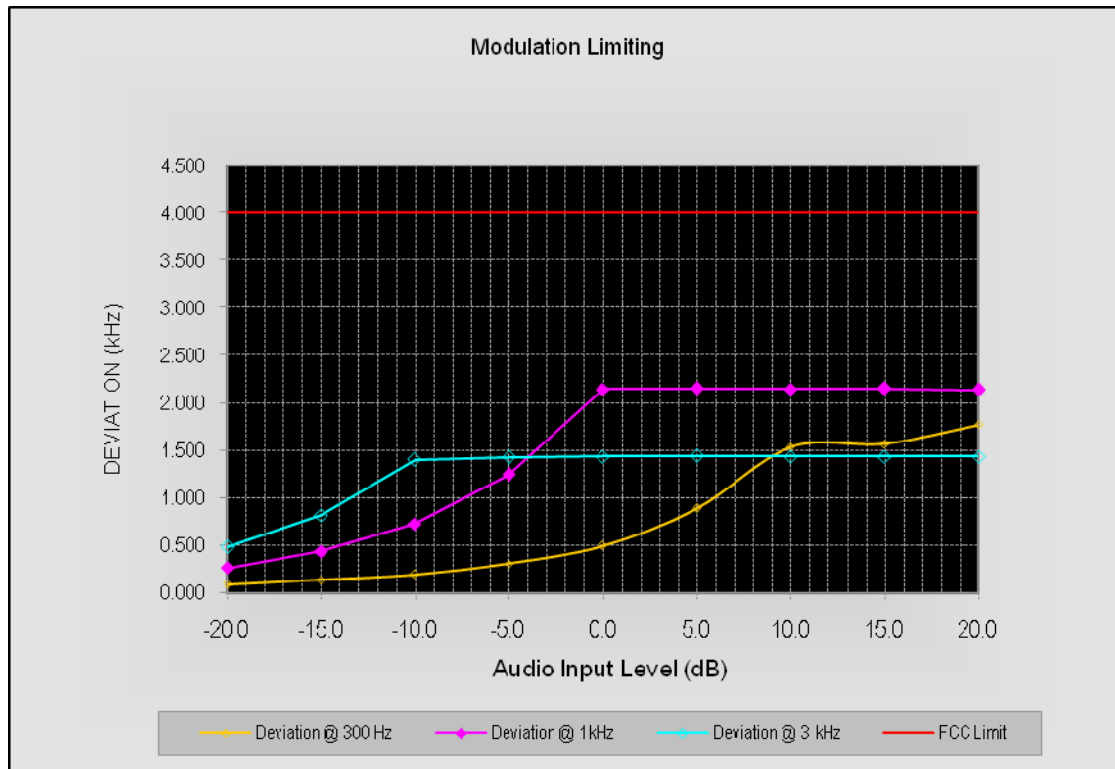

Carrier Frequency: 868.9875 MHz, Channel Separation=12.5 kHz

Audio Input Level [dB]	Frequency Deviation (kHz)			Limit [kHz]
	@ 300 Hz	@ 1kHz	@ 3 kHz	
20.0	1.783	2.148	1.439	5.0
15.0	1.575	2.145	1.435	5.0
10.0	1.564	2.147	1.432	5.0
5.0	0.911	2.152	1.437	5.0
0.0	0.503	2.143	1.430	5.0
-5.0	0.324	1.239	1.422	5.0
-10.0	0.201	0.772	1.385	5.0
-15.0	0.142	0.461	0.833	5.0
-20.0	0.093	0.270	0.476	5.0

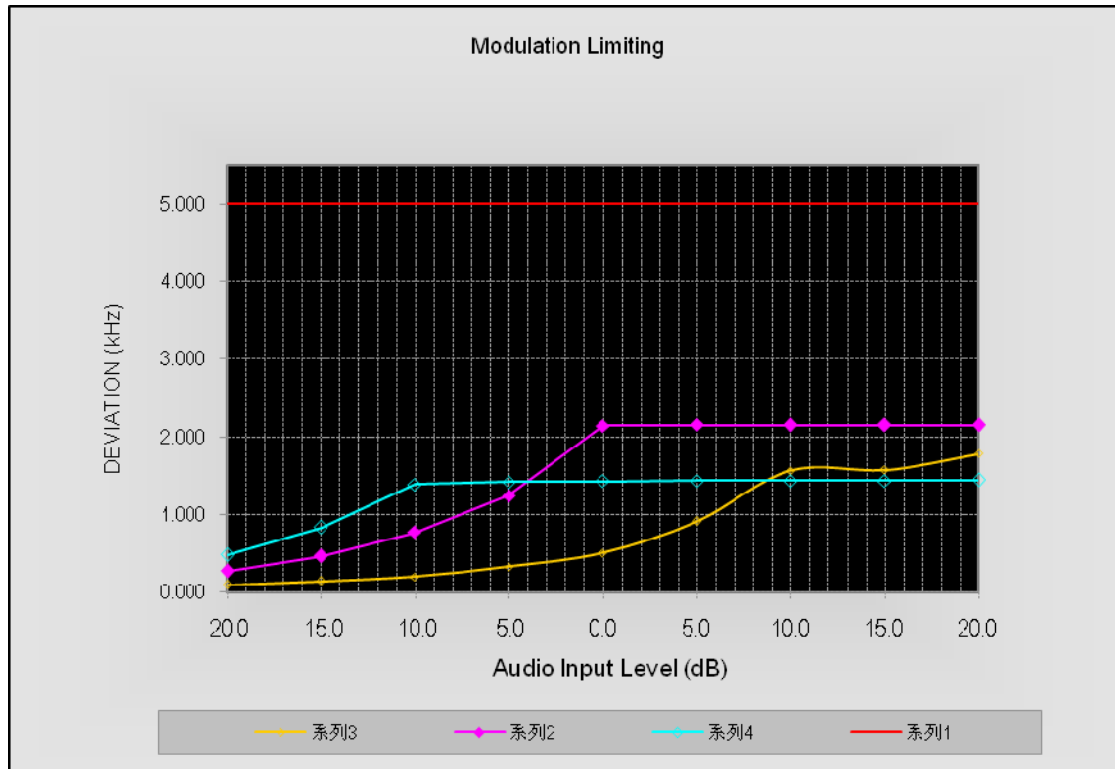

Carrier Frequency: 939.9875 MHz, Channel Separation=12.5 kHz

Audio Input Level [dB]	Frequency Deviation (kHz)			Limit [kHz]
	@ 300 Hz	@ 1kHz	@ 3 kHz	
20.0	1.315	2.083	1.743	2.5
15.0	1.156	2.069	1.736	2.5
10.0	1.028	1.964	1.740	2.5
5.0	0.584	1.843	1.444	2.5
0.0	0.360	1.500	1.026	2.5
-5.0	0.206	0.843	0.793	2.5
-10.0	0.148	0.497	0.588	2.5
-15.0	0.101	0.298	0.349	2.5
-20.0	0.077	0.186	0.220	2.5

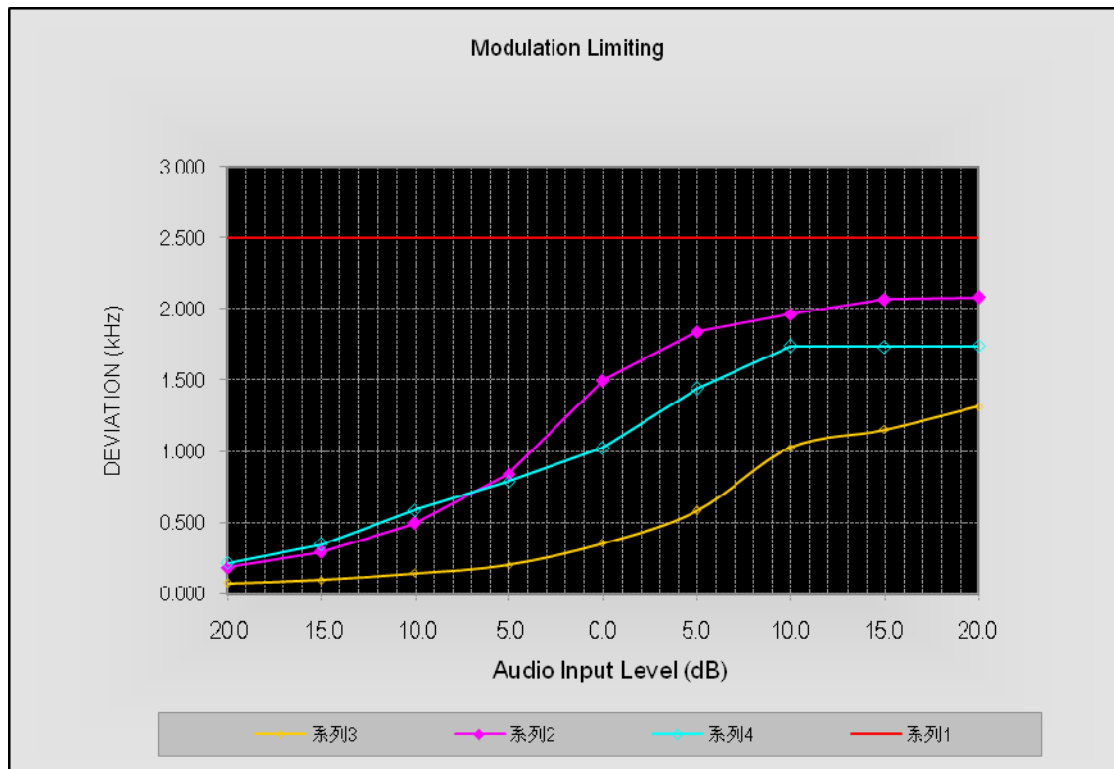

Audio Frequency Response

Carrier Frequency: 851.0125 MHz, Channel Separation=12.5 kHz

Audio Frequency (Hz)	Response Attenuation (dB)
300	-11.24
400	-7.74
500	-5.81
600	-4.15
700	-2.66
800	-1.33
900	-0.76
1000	0.00
1200	1.64
1400	2.84
1600	4.25
1800	4.93
2000	5.92
2100	6.23
2200	6.54
2300	6.98
2400	7.26
2500	7.17
2600	7.15
2700	7.12
2800	7.06
2900	6.83
3000	6.21

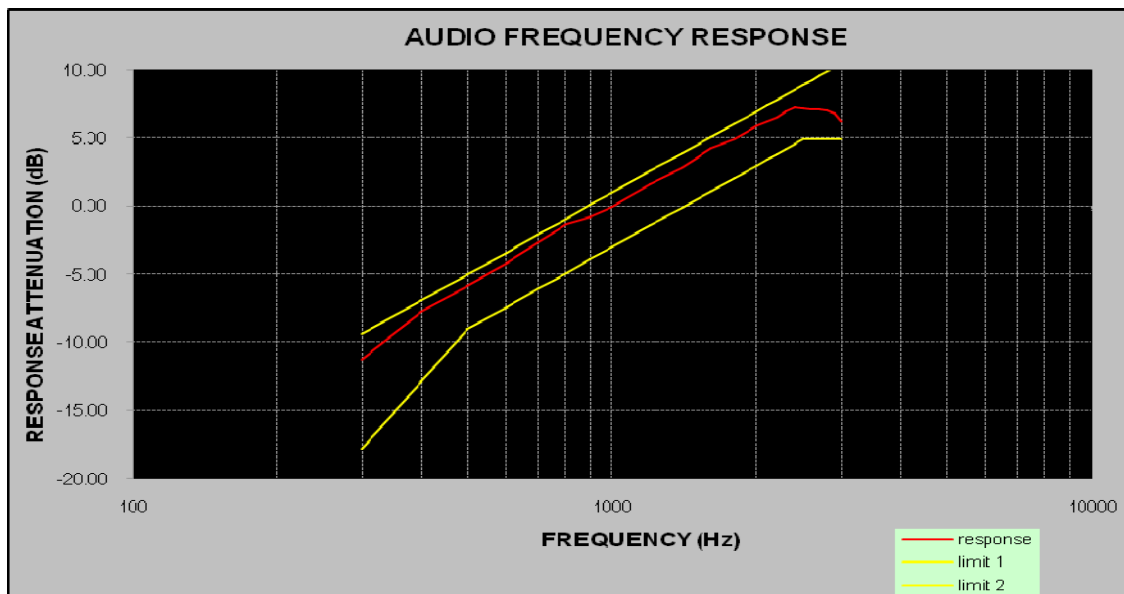

Carrier Frequency: 868.9875 MHz, Channel Separation=12.5 kHz

Audio Frequency (Hz)	Response Attenuation (dB)
300	-11.70
400	-8.09
500	-6.23
600	-4.29
700	-2.88
800	-1.60
900	-1.05
1000	0.00
1200	1.33
1400	2.57
1600	4.11
1800	4.71
2000	5.80
2100	6.09
2200	6.44
2300	6.82
2400	7.04
2500	7.14
2600	7.07
2700	6.95
2800	6.86
2900	6.46
3000	6.17

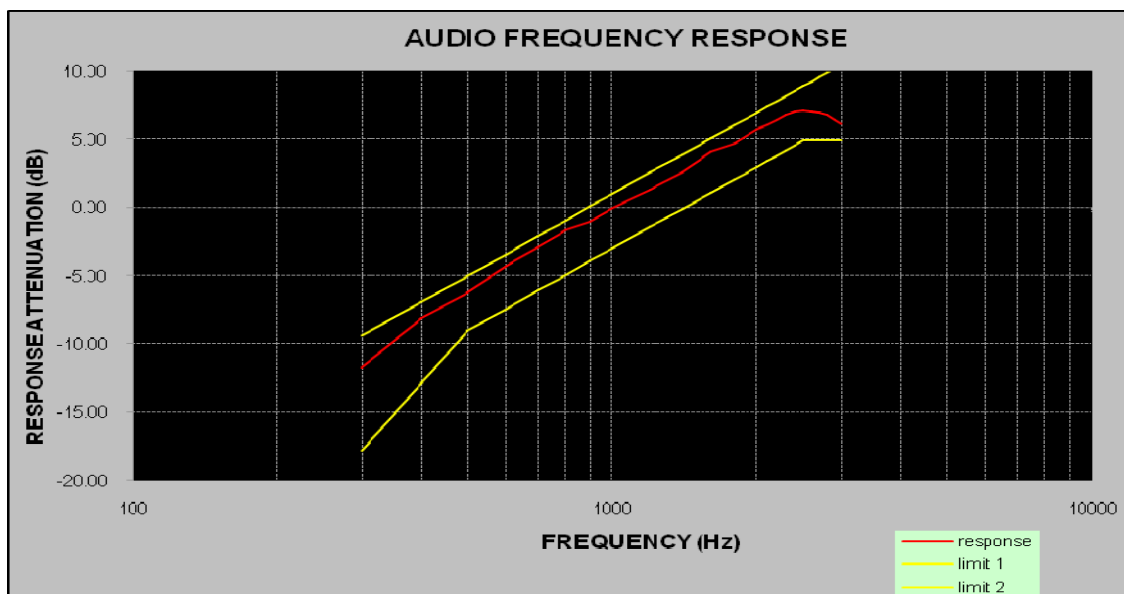

Carrier Frequency: 939.9875 MHz, Channel Separation=12.5 kHz

Audio Frequency (Hz)	Response Attenuation (dB)
300	-10.93
400	-7.79
500	-5.75
600	-4.10
700	-2.76
800	-1.41
900	-0.43
1000	0.14
1200	1.83
1400	3.05
1600	4.48
1800	5.18
2000	6.18
2100	6.47
2200	6.82
2300	7.13
2400	7.56
2500	7.52
2600	7.49
2700	7.36
2800	7.30
2900	7.04
3000	6.59

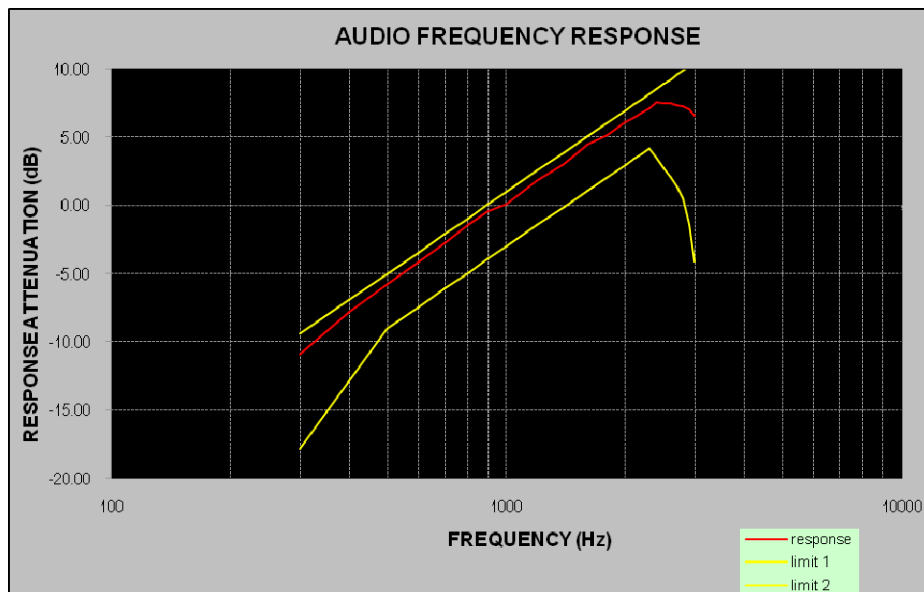

Audio Frequency Low Pass Filter Response

Analog Modulation:

Carrier Frequency: 851.0125 MHz, Channel Separation=12.5 kHz

Audio Frequency (kHz)	Response Attenuation (dB)	FCC Limit (dB)
3.0	-3.8	0.0
4.0	-14.8	-7.5
5.0	-18.3	-13.3
6.0	-30.6	-18.1
7.0	-31.8	-22.1
8.0	-37.8	-25.6
9.0	-42.3	-28.6
10.0	-47.3	-31.4
15.0	-55.7	-41.9
20.0	-62.4	-50.0
30.0	-64.6	-50.0
40.0	-68.6	-50.0
50.0	-72.0	-50.0

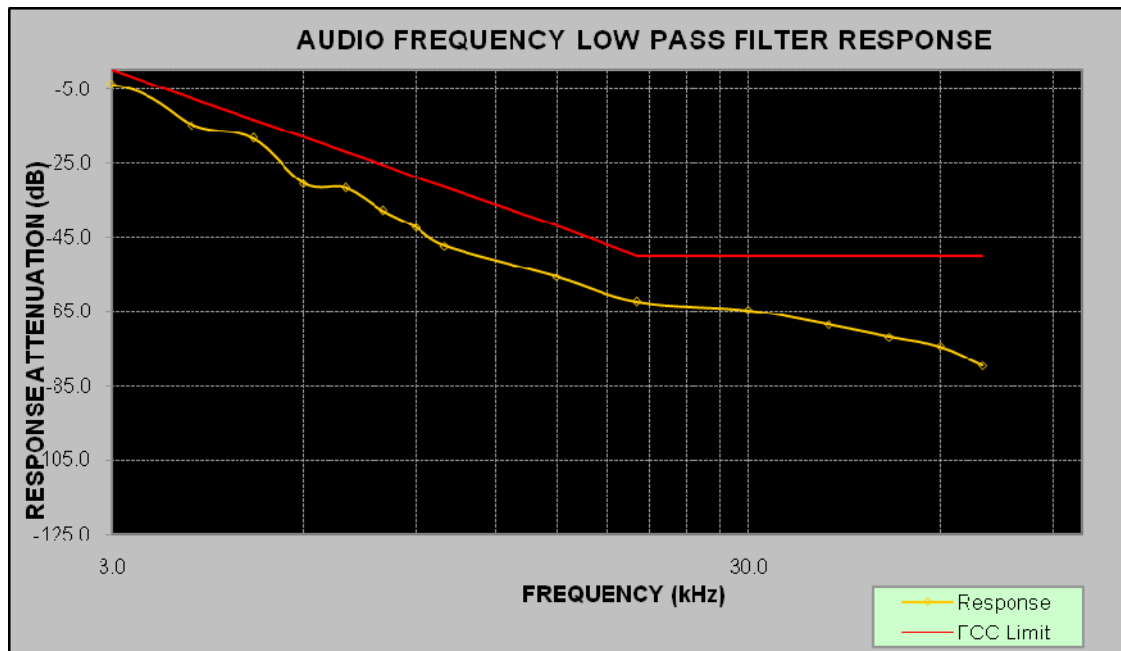

Carrier Frequency: 868.9875 MHz, Channel Separation=12.5 kHz

Audio Frequency (kHz)	Response Attenuation (dB)	FCC Limit (dB)
3.0	-4.8	0.0
4.0	-14.8	-7.5
5.0	-18.1	-13.3
6.0	-31.4	-18.1
7.0	-31.9	-22.1
8.0	-38.3	-25.6
9.0	-42.2	-28.6
10.0	-47.2	-31.4
15.0	-55.3	-41.9
20.0	-62.9	-50.0
30.0	-65.5	-50.0
40.0	-68.8	-50.0
50.0	-71.9	-50.0

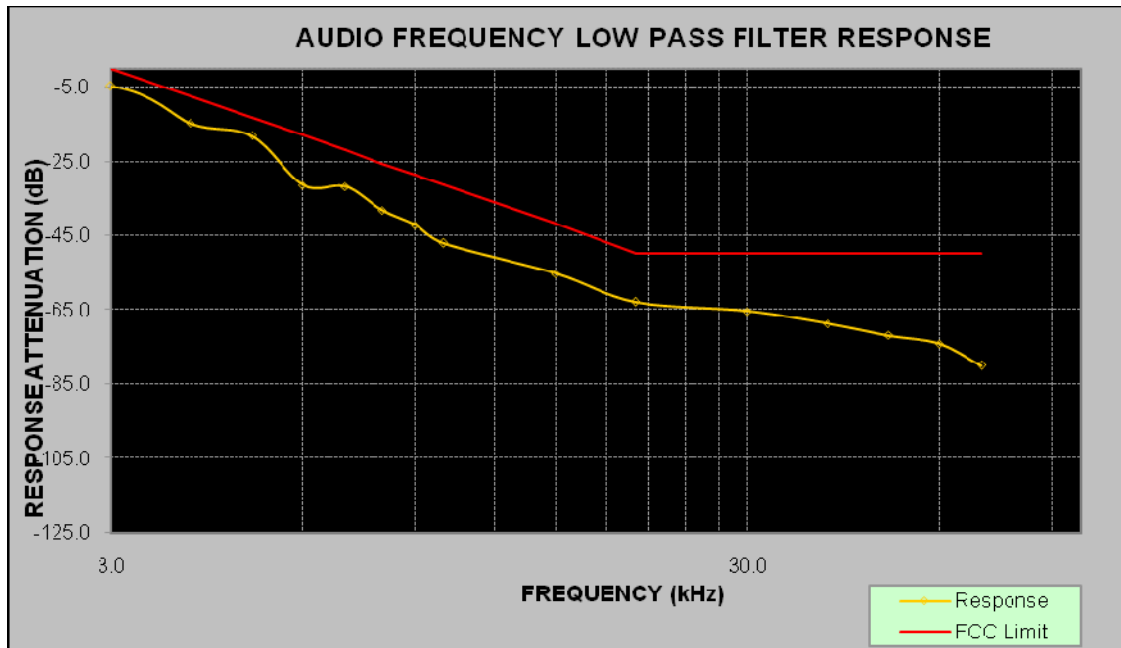

Carrier Frequency: 939.9875 MHz, Channel Separation=12.5 kHz

Audio Frequency (kHz)	Response Attenuation (dB)	FCC Limit (dB)
3.0	-3.9	0.0
4.0	-20.6	-12.5
5.0	-26.8	-22.2
6.0	-35.0	-30.1
7.0	-46.4	-36.8
8.0	-55.4	-42.6
9.0	-60.8	-47.7
10.0	-68.4	-52.3
12.0	-78.2	-60.2
14.0	-79.4	-66.9
16.0	-81.9	-72.7
18.0	-87.9	-77.8
20.0	-90.0	-82.5

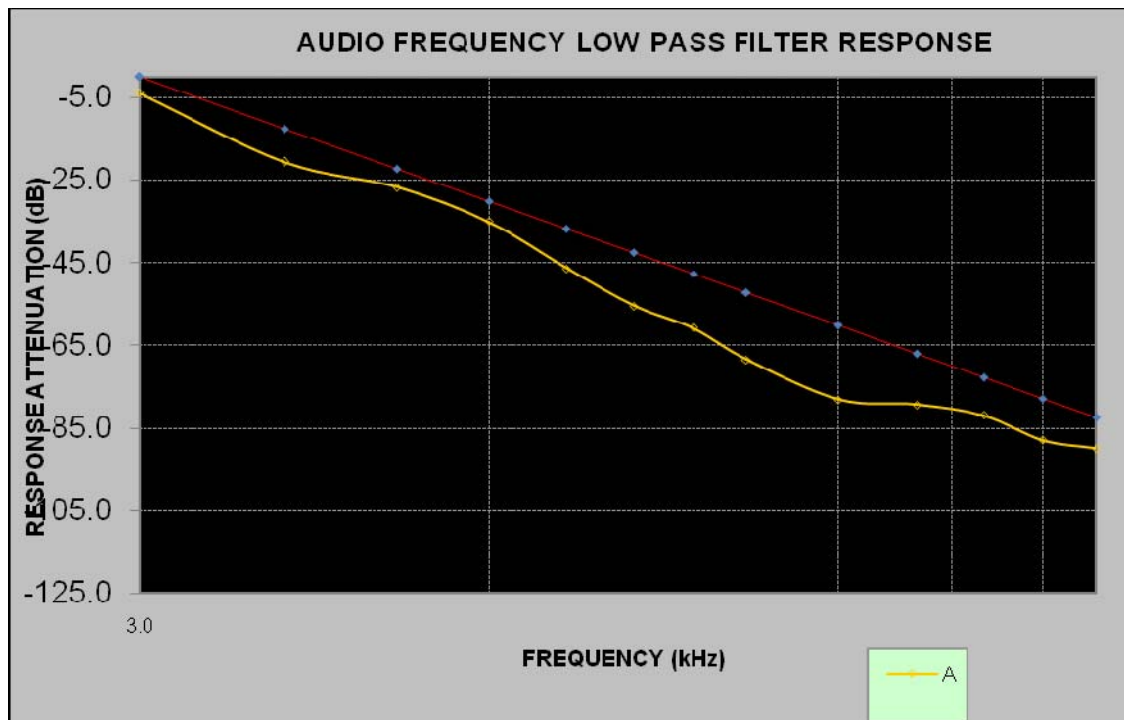

FCC §2.1049 & §90.209 & §90.210 – OCCUPIED BANDWIDTH & EMISSION MASK

Applicable Standard

FCC §2.1049, §90.209 and §90.210

Emission Mask B. For transmitters that are equipped with an audio low-pass filter, the power of any emission must be attenuated below the unmodulated carrier power (P) as follows:

- (1) On any frequency removed from the assigned frequency by more than 50 percent, but not more than 100 percent of the authorized bandwidth: At least 25 dB.
- (2) On any frequency removed from the assigned frequency by more than 100 percent, but not more than 250 percent of the authorized bandwidth: At least 35 dB.
- (3) On any frequency removed from the assigned frequency by more than 250 percent of the authorized bandwidth: At least $43 + 10 \log (P)$ dB.

Emission Mask I. For transmitters that are equipped with an audio low pass filter, the power of any emission must be attenuated below the unmodulated carrier power of the transmitter (P) as follows:

- (1) On any frequency removed from the center of the authorized bandwidth by a displacement frequency of more than 6.8 kHz, but no more than 9.0 kHz: At least 25 dB;
- (2) On any frequency removed from the center of the authorized bandwidth by a displacement frequency of more than 9.0 kHz, but no more than 15 kHz: At least 35 dB;
- (3) On any frequency removed from the center of the authorized bandwidth by a displacement frequency of more than 15 kHz: At least $43 + 10 \log (P)$ dB, or 70 dB, whichever is the lesser attenuation.

Test Equipment List and Details

Manufacturer	Description	Model No.	Serial No.	Calibration Date	Calibration Due Date
Rohde & Schwarz	Signal Analyzer	FSIQ26	8386001028	2013-11-12	2014-11-12
HP	RF Communication Test Set	8920A	3325U00859	2013-05-07	2014-05-07

* **Statement of Traceability:** Bay Area Compliance Laboratories Corp. (Shenzhen) attests that all calibrations have been performed in accordance to requirements, traceable to National Primary Standards and International System of Units (SI).

Test Procedure

The RF output of the transmitter was connected to the input of the spectrum analyzer through sufficient attenuation.

The resolution bandwidth of the spectrum analyzer was set at 100 Hz and the spectrum was recorded in the frequency band ± 50 kHz from the carrier frequency.

Test Data

Environmental Conditions

Temperature:	20 ~ 25 °C
Relative Humidity:	50 ~ 56 %
ATM Pressure:	101.0 kPa

The testing was performed by Candy Li from 2014-03-05 to 2014-04-18.

Modulation	Channel Separation (kHz)	Frequency (MHz)	99% Occupied Bandwidth (kHz)	26 dB Emissions Bandwidth (kHz)	Power Level
Analog	12.5	851.0125	9.52	10.62	High Power
	12.5	851.0125	9.52	10.62	Low Power
	12.5	868.9875	9.42	10.62	High Power
	12.5	868.9875	9.42	10.62	Low Power
	12.5	939.9875	9.86	10.70	High Power
	12.5	939.9875	9.82	10.62	Low Power
	12.5	940.9875	9.92	10.22	High Power
	12.5	940.9875	9.92	10.32	Low Power
Digital	12.5	851.0125	7.72	9.62	High Power
	12.5	851.0125	7.62	9.92	Low Power
	12.5	868.9875	7.62	9.42	High Power
	12.5	868.9875	7.72	10.32	Low Power
	12.5	939.9875	7.70	10.46	High Power
	12.5	939.9875	7.62	9.92	Low Power
	12.5	940.9875	7.77	9.81	High Power
	12.5	940.9875	7.77	9.81	Low Power

Analog Modulation:

851.0125 MHz: 99% Occupied & 26 dB Bandwidth with High Power

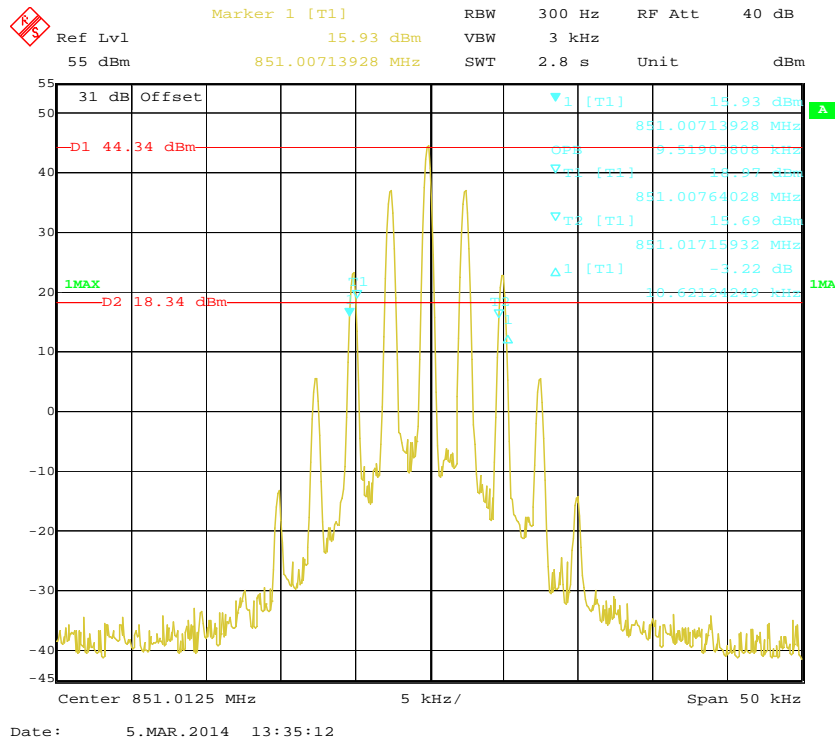

851.0125 MHz: 99% Occupied & 26 dB Bandwidth with Low Power

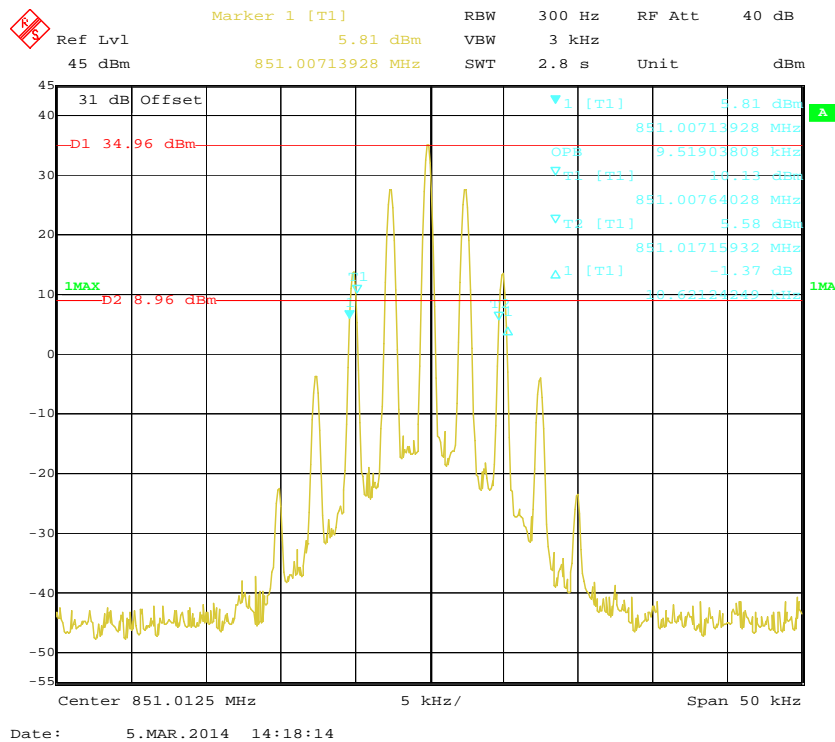

851.0125 MHz: Emission Mask with High Power

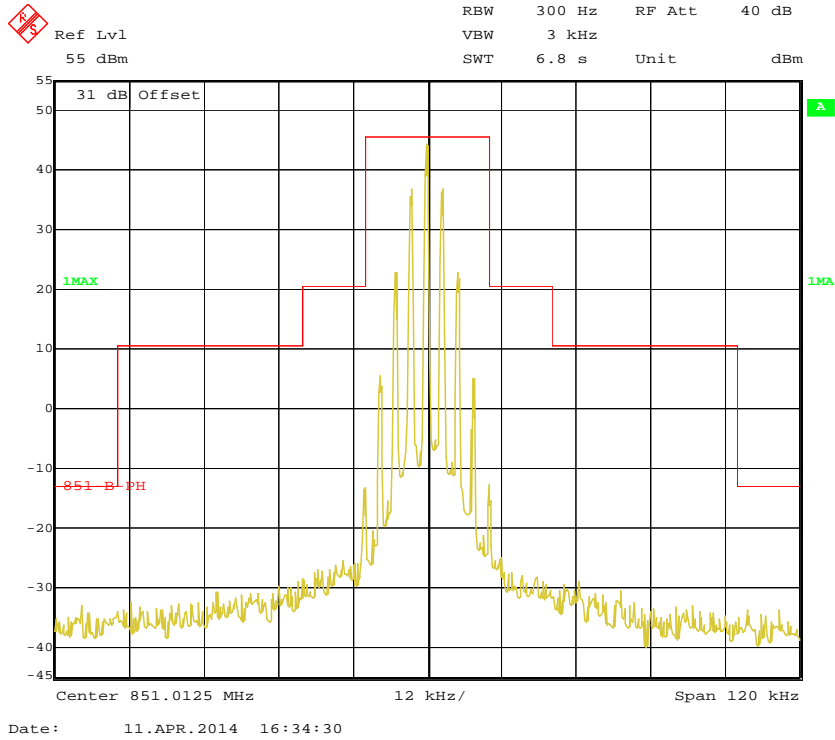

851.0125 MHz: Emission Mask with Low Power

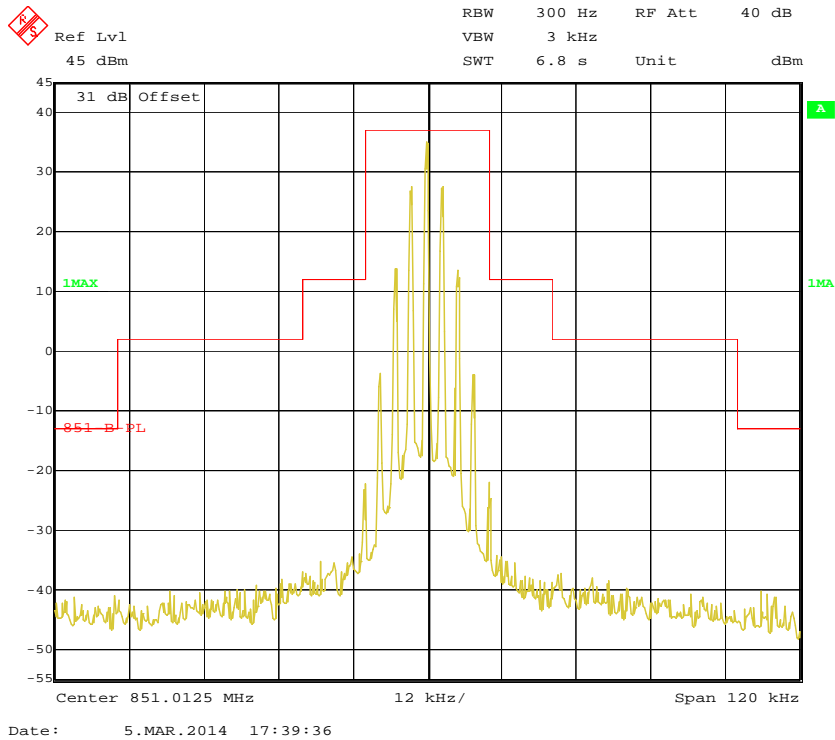

868.9875 MHz: 99% Occupied & 26 dB Bandwidth with High Power

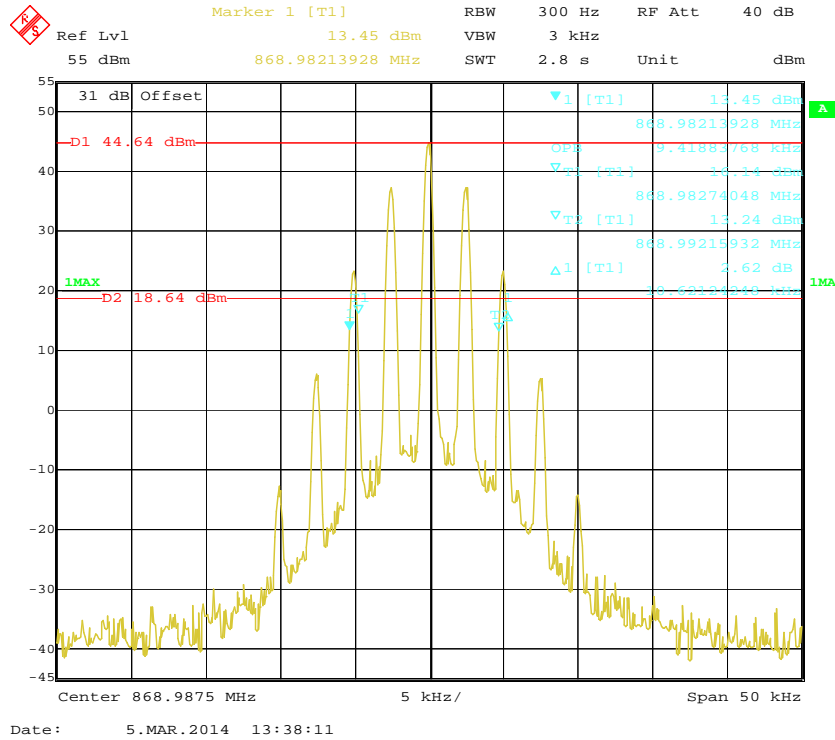

868.9875 MHz: 99% Occupied & 26 dB Bandwidth with Low Power

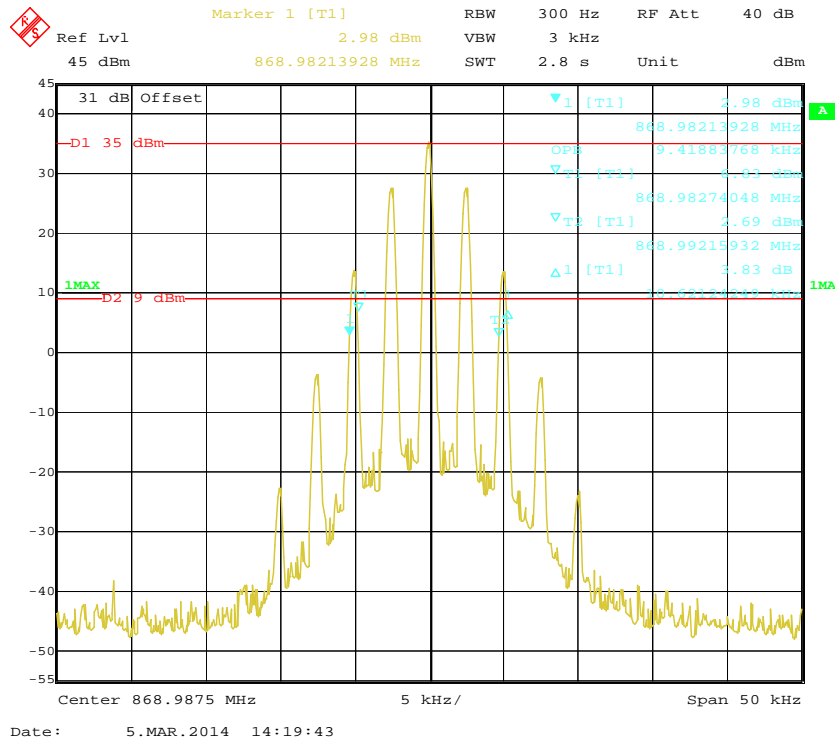

868.9875 MHz: Emission Mask with High Power

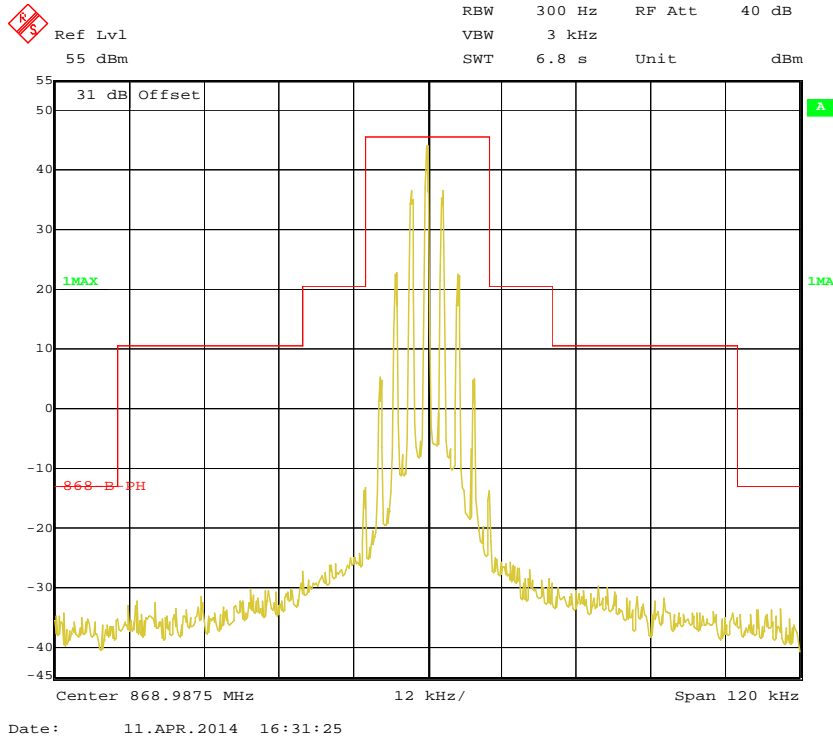

868.9875 MHz: Emission Mask with Low Power

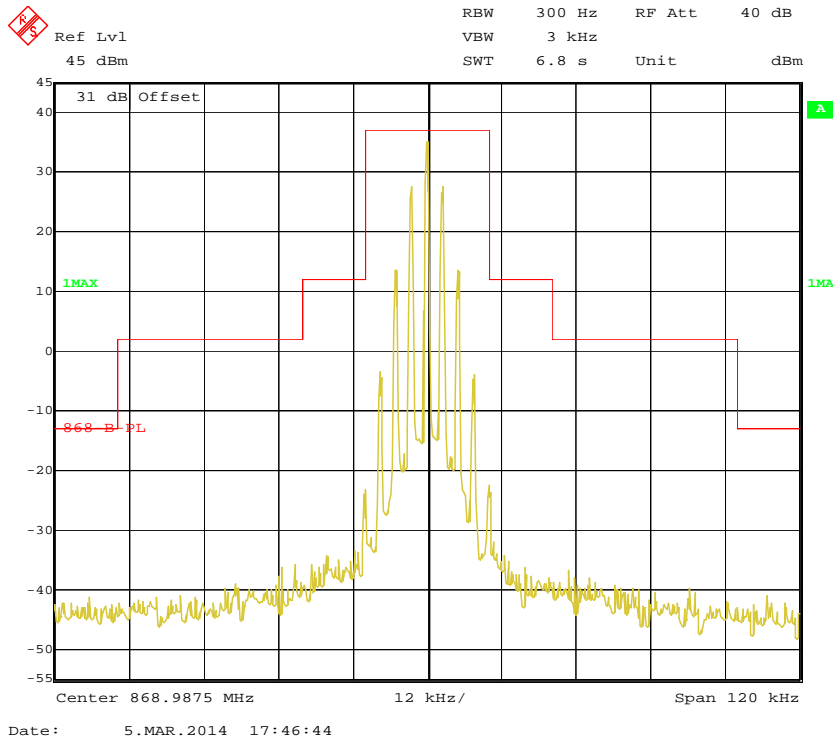

939.9875 MHz: 99% Occupied & 26 dB Bandwidth with High Power

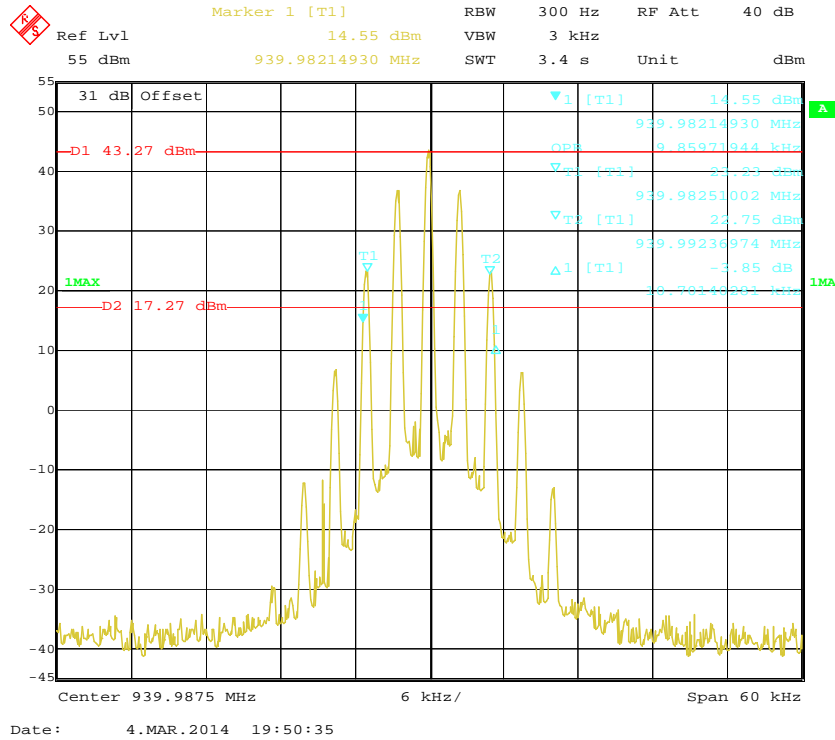

939.9875 MHz: 99% Occupied & 26 dB Bandwidth with Low Power

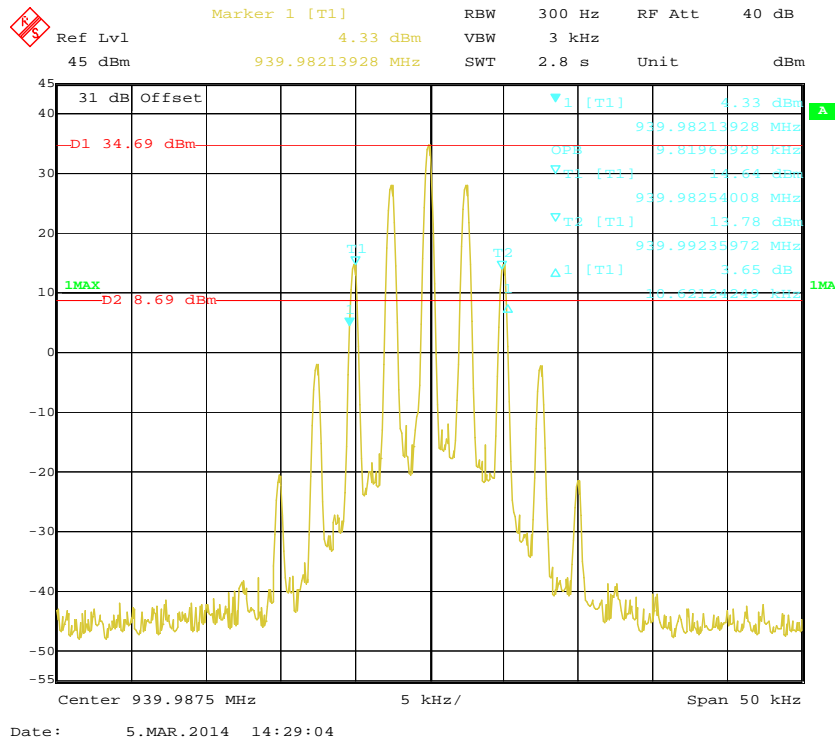

939.9875 MHz: Emission Mask with High Power

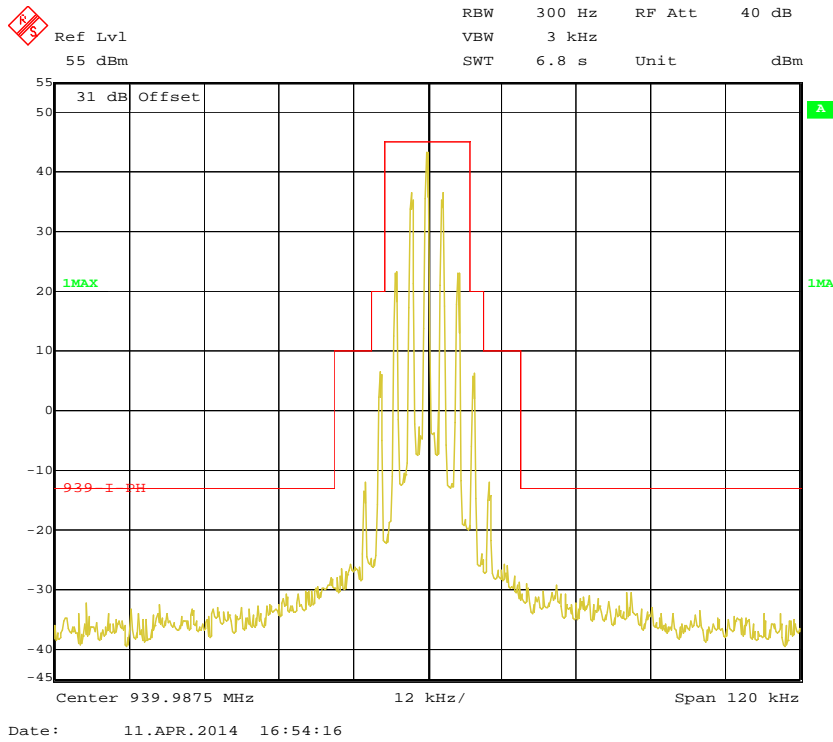

939.9875 MHz: Emission Mask with Low Power

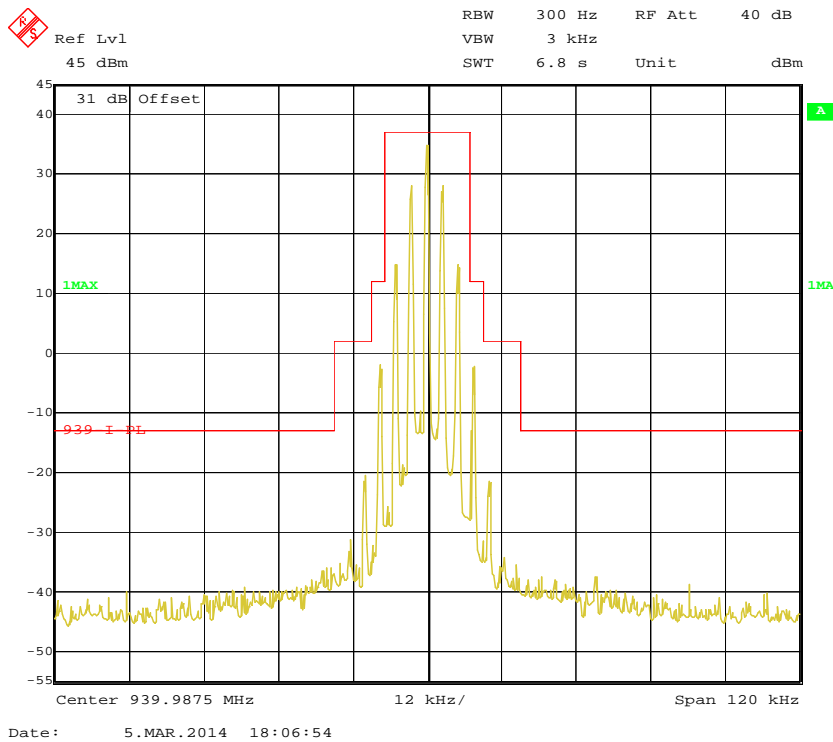

940.9875 MHz: 99% Occupied & 26 dB Bandwidth with High Power

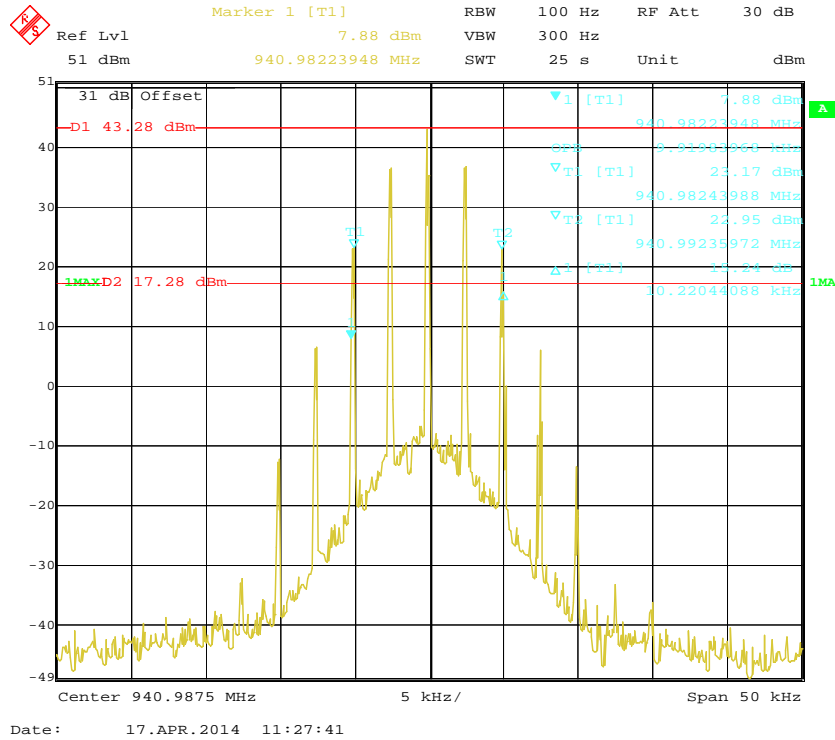

940.9875 MHz: 99% Occupied & 26 dB Bandwidth with Low Power

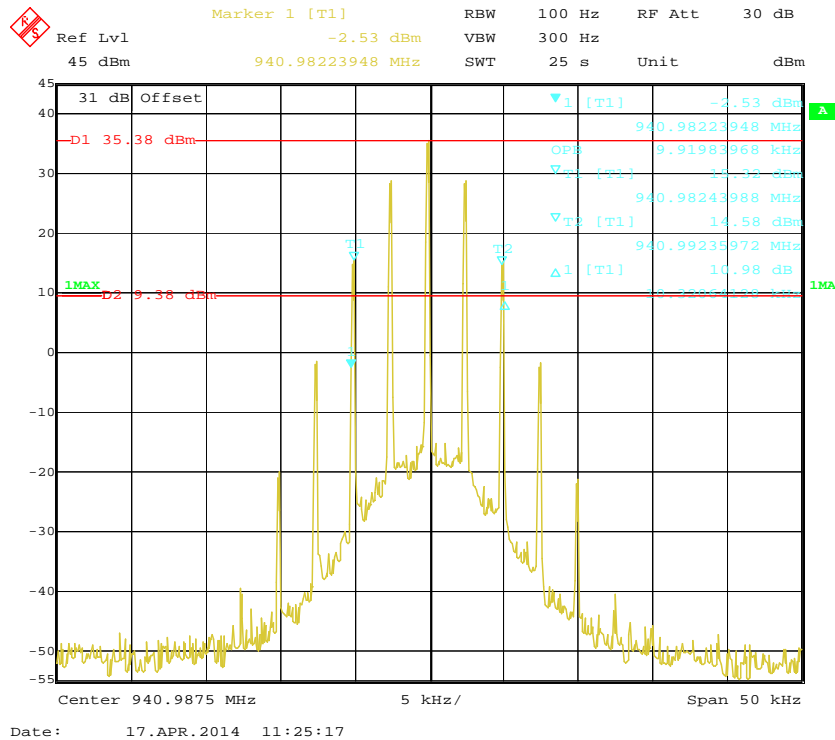

940.9875 MHz: Emission Mask with High Power

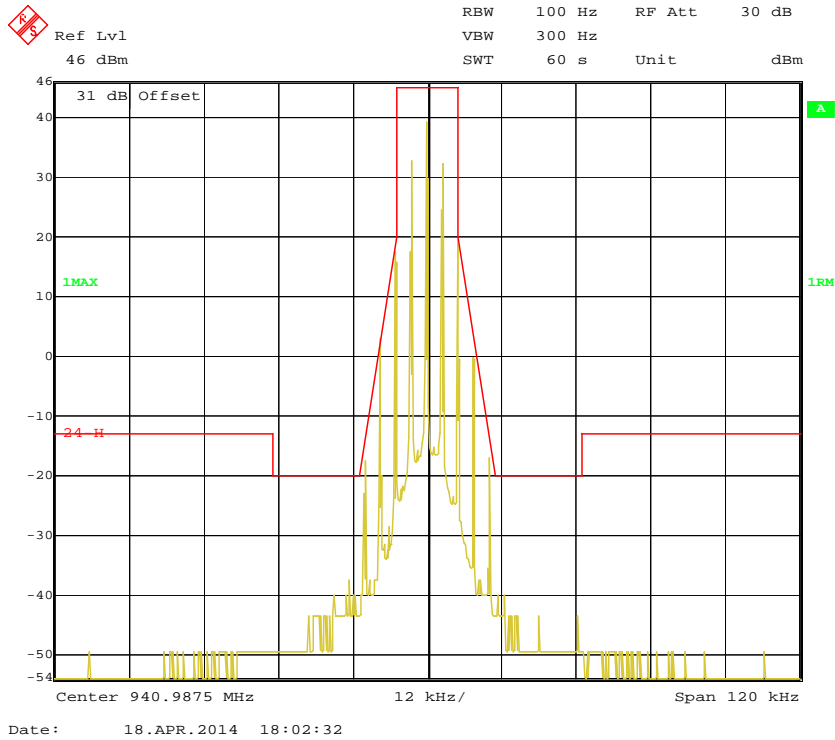

940.9875 MHz: Emission Mask with Low Power

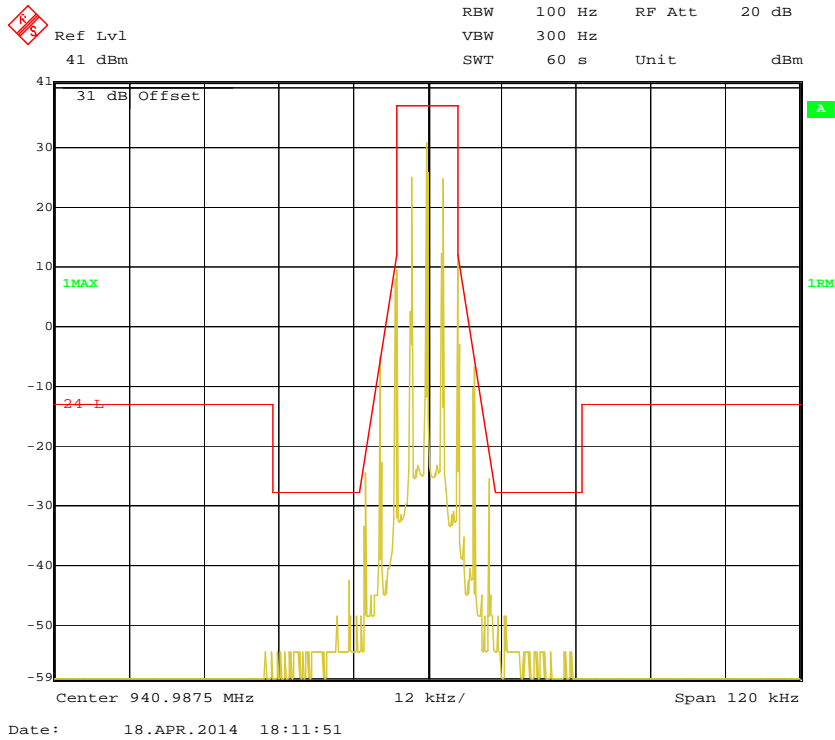

Digital Modulation:

851.0125 MHz: 99% Occupied & 26 dB Bandwidth with High Power

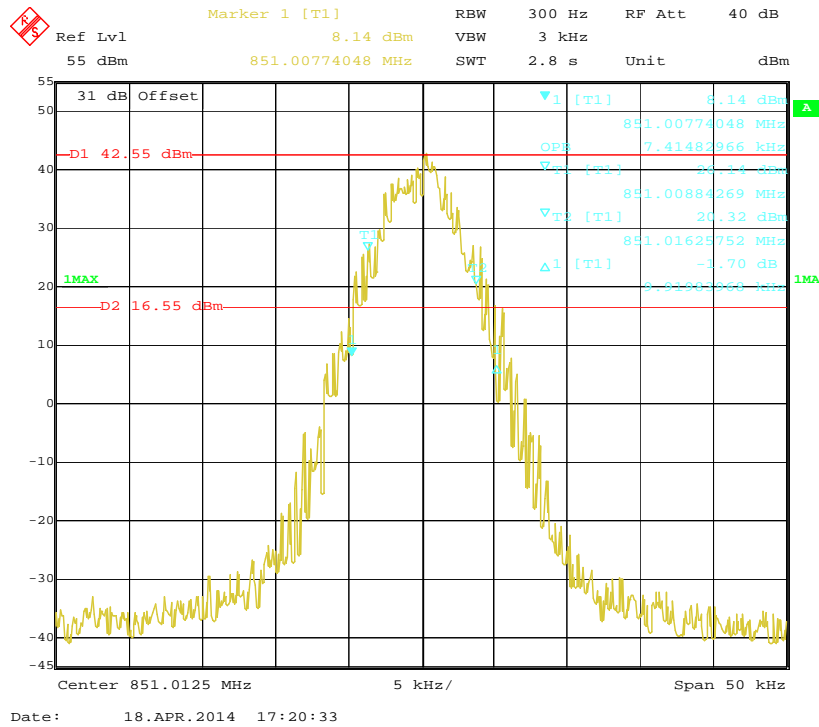

851.0125 MHz: 99% Occupied & 26 dB Bandwidth with Low Power

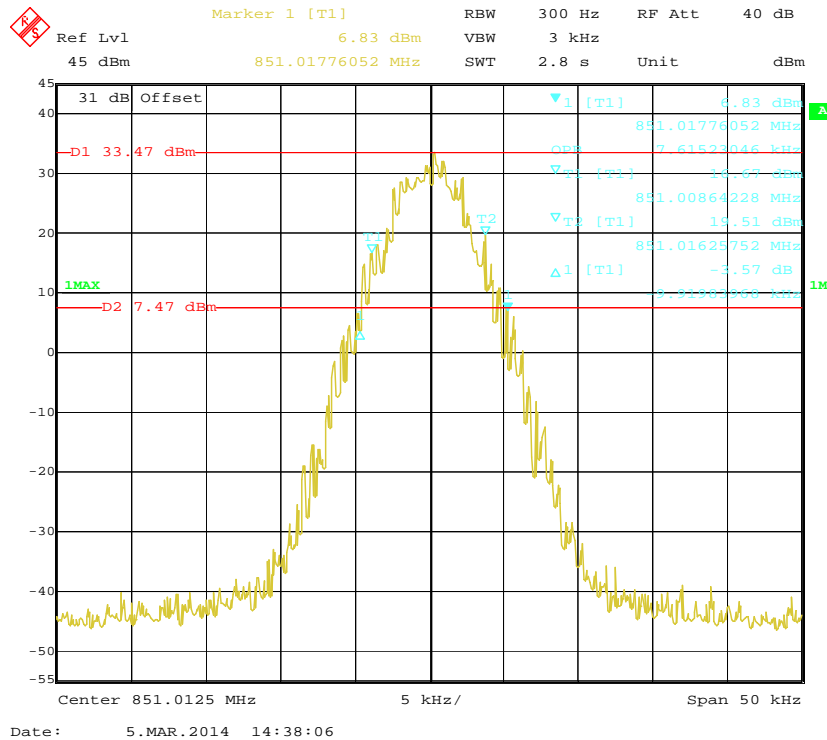

851.0125 MHz: Emission Mask with High Power

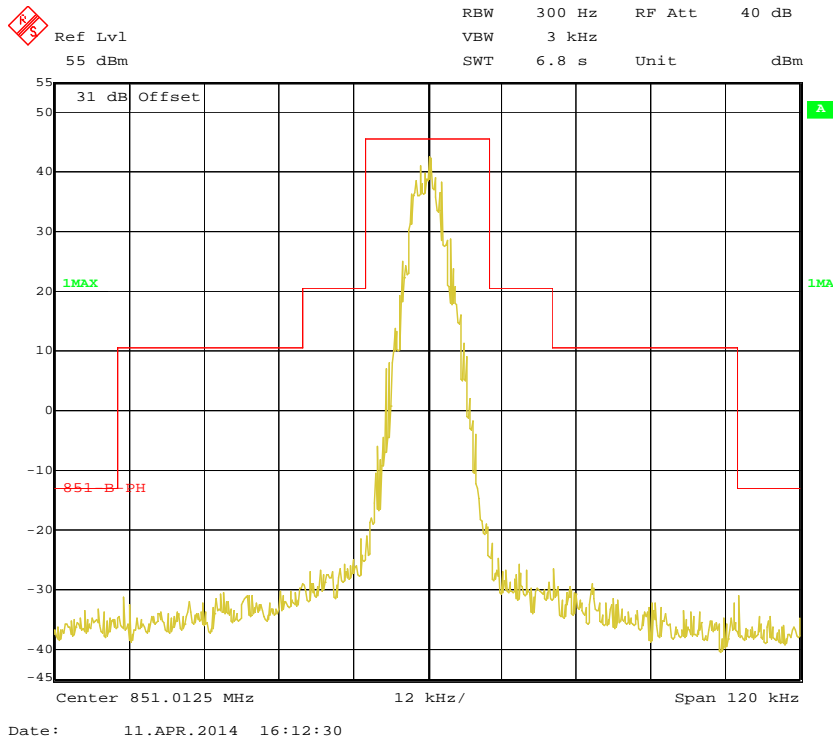

851.0125 MHz: Emission Mask with Low Power

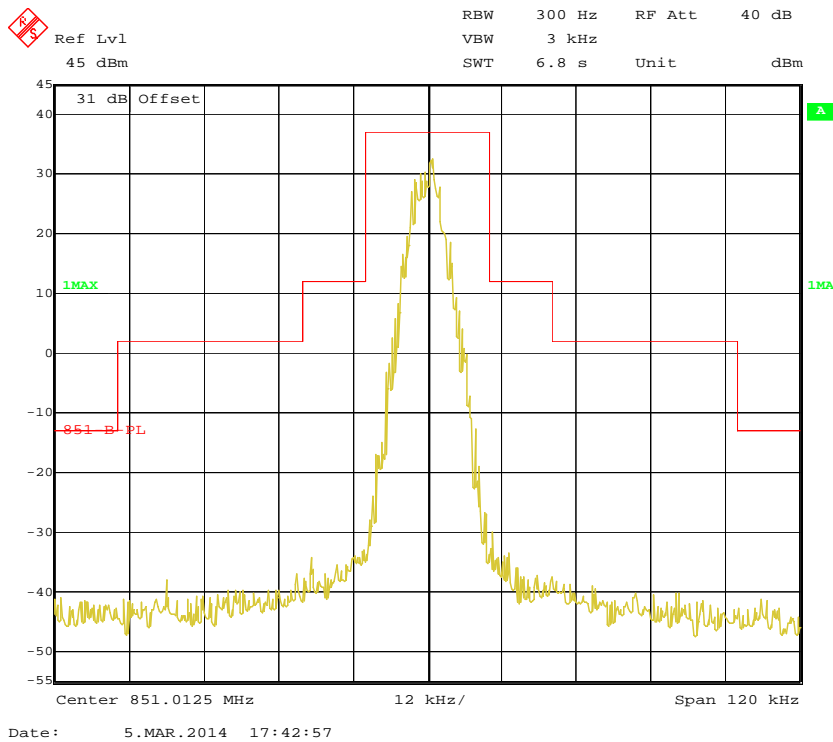

868.9875 MHz: 99% Occupied & 26 dB Bandwidth with High Power

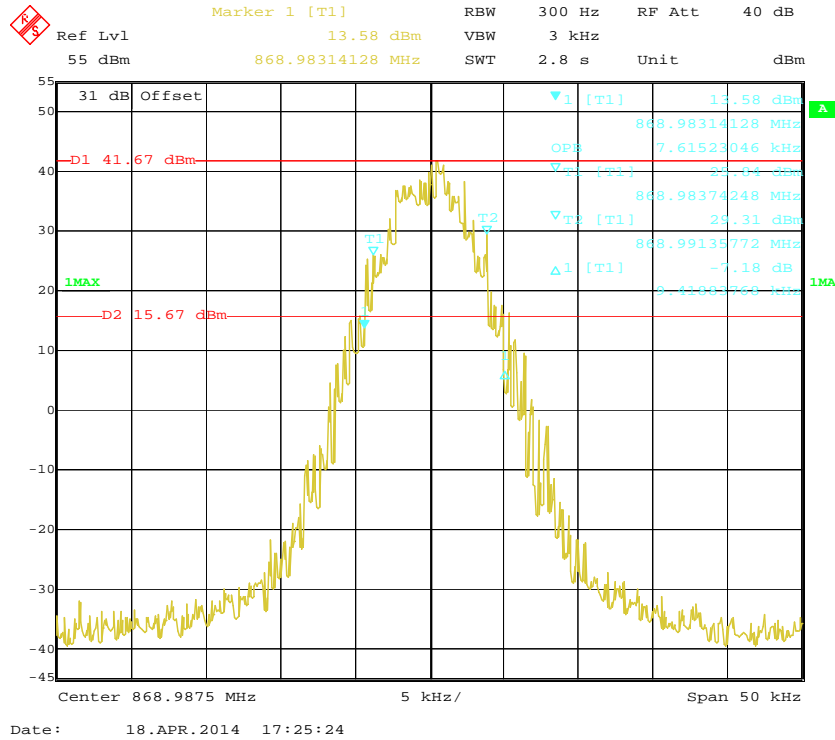

868.9875 MHz: 99% Occupied & 26 dB Bandwidth with Low Power

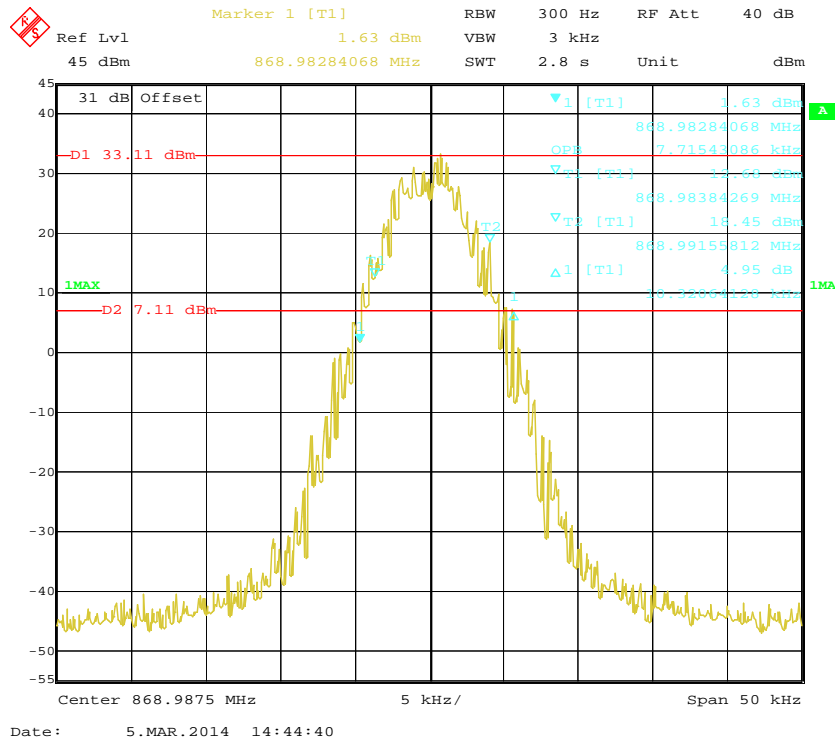

868.9875 MHz: Emission Mask with High Power

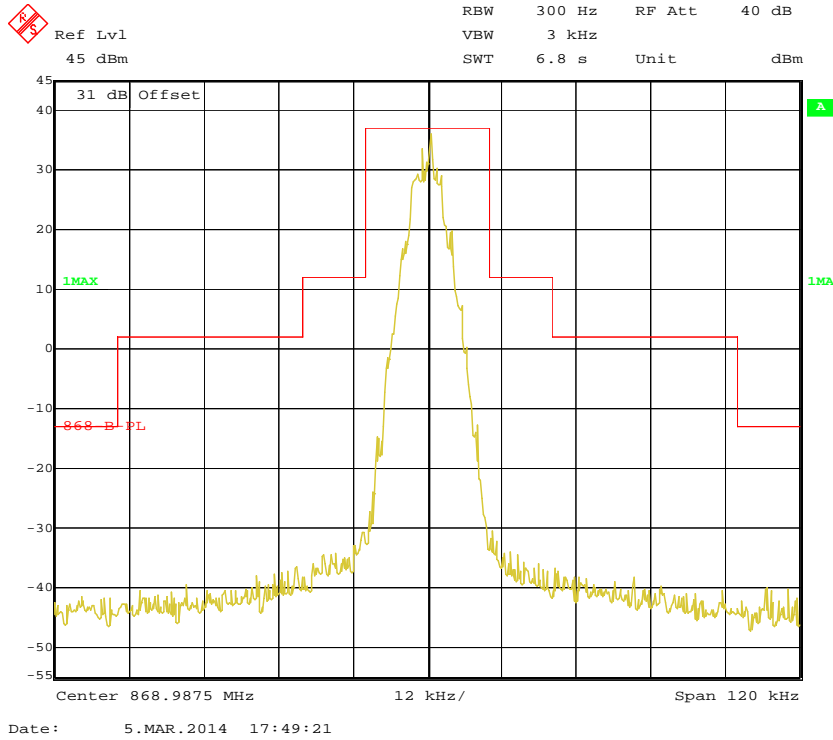

868.9875 MHz: Emission Mask with Low Power

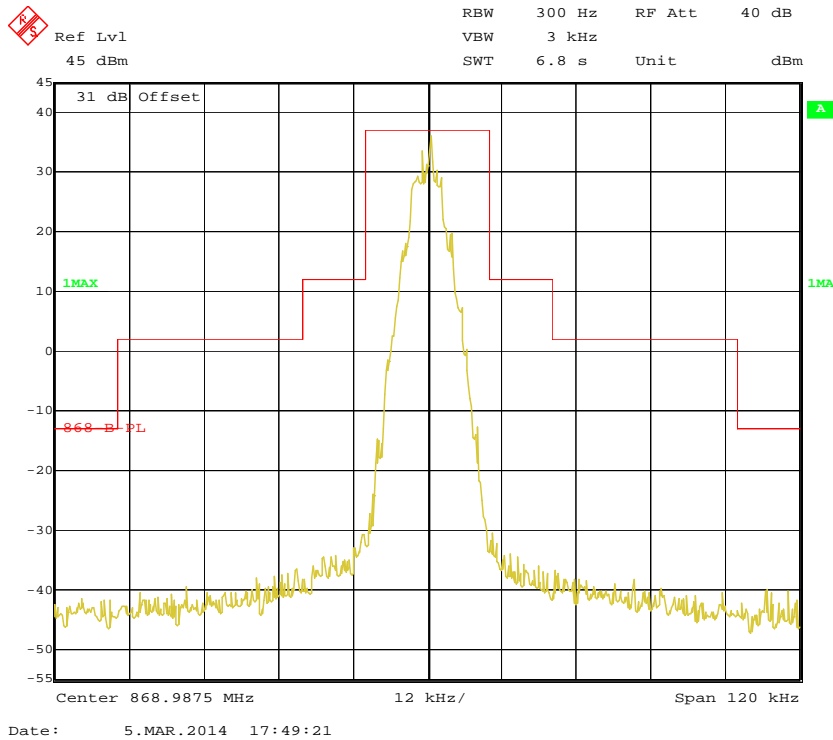

939.9875 MHz: 99% Occupied & 26 dB Bandwidth with High Power

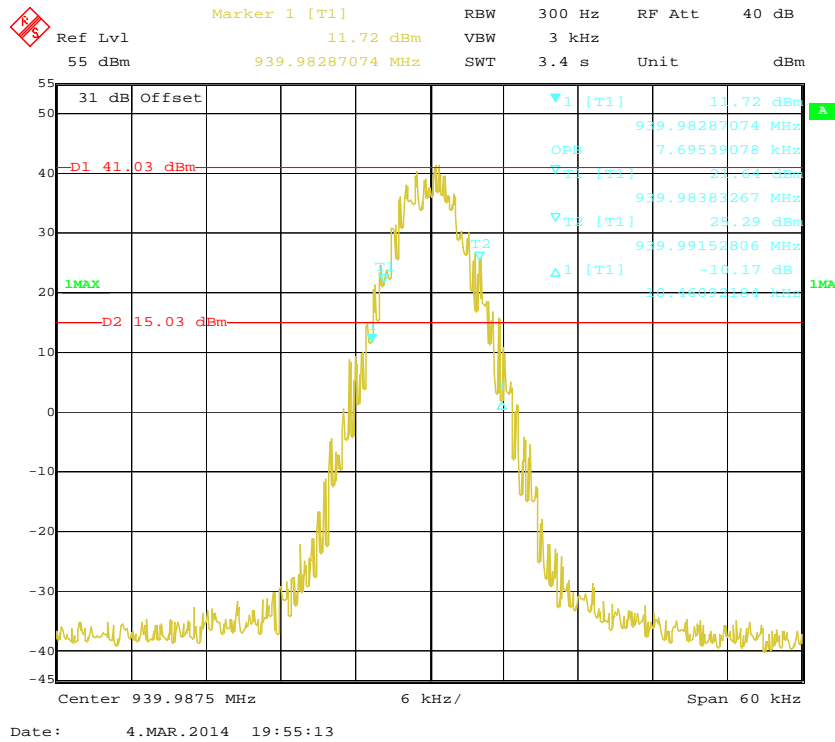

939.9875 MHz: 99% Occupied & 26 dB Bandwidth with Low Power

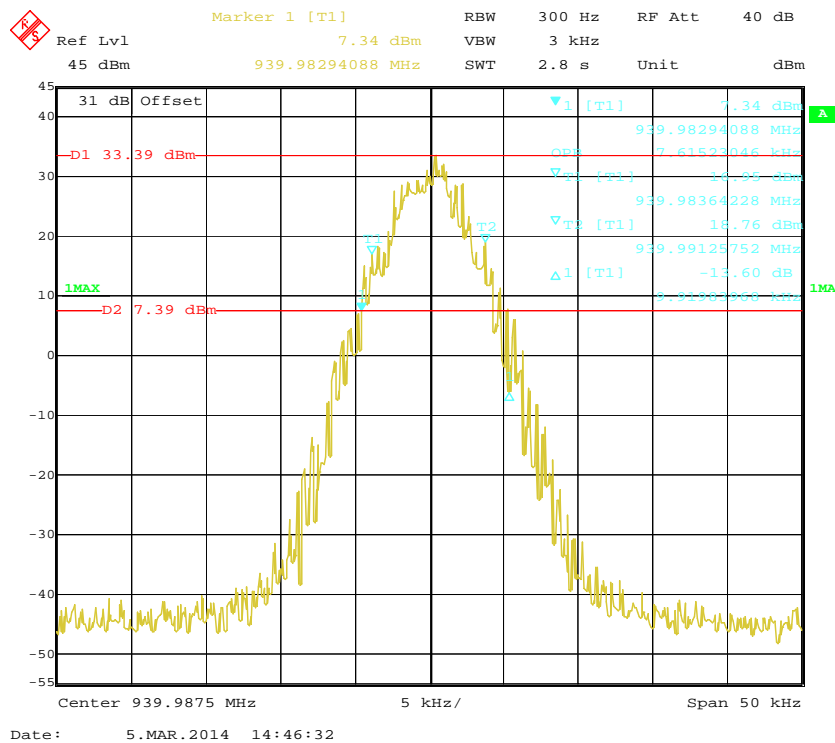

939.9875 MHz: Emission Mask with High Power

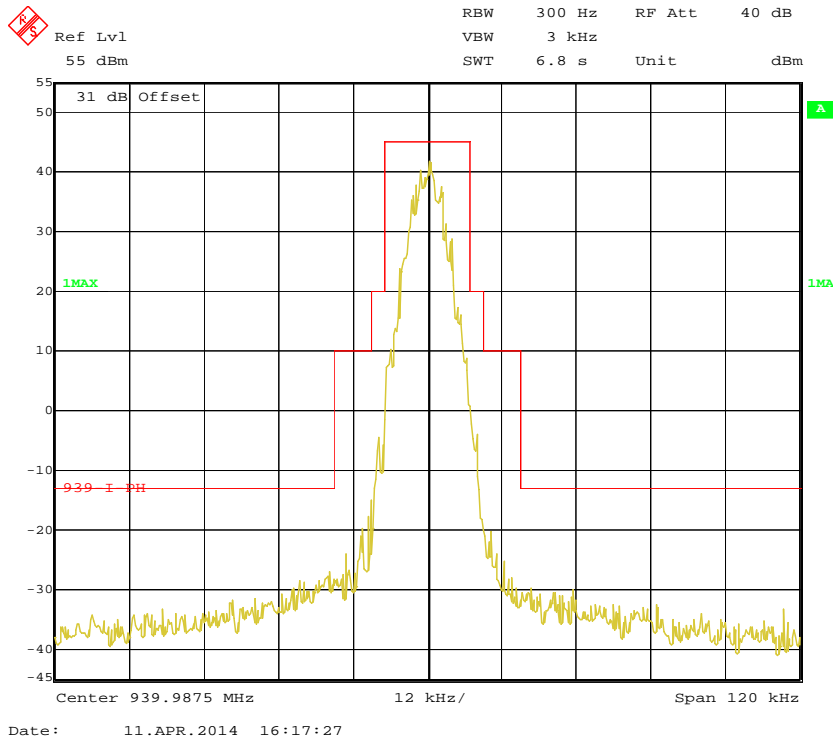

939.9875 MHz: Emission Mask with Low Power

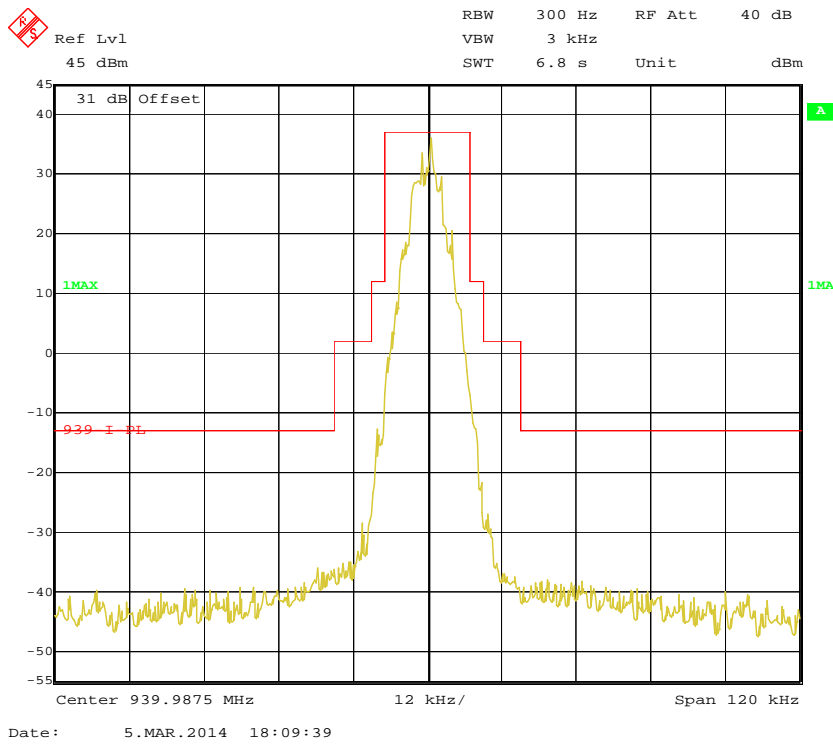

940.9875 MHz: 99% Occupied & 26 dB Bandwidth with High Power

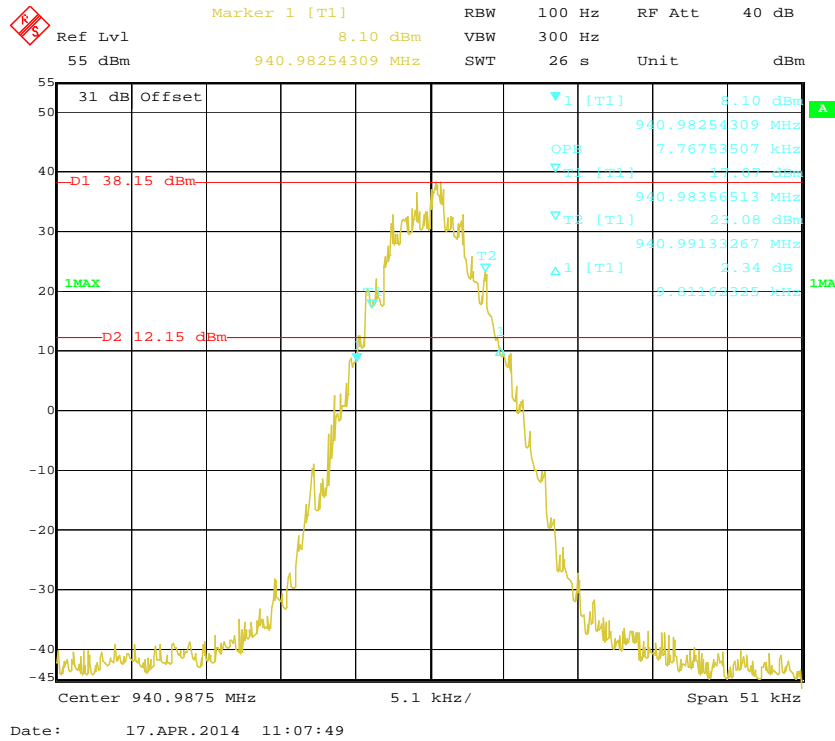

940.9875 MHz: 99% Occupied & 26 dB Bandwidth with Low Power

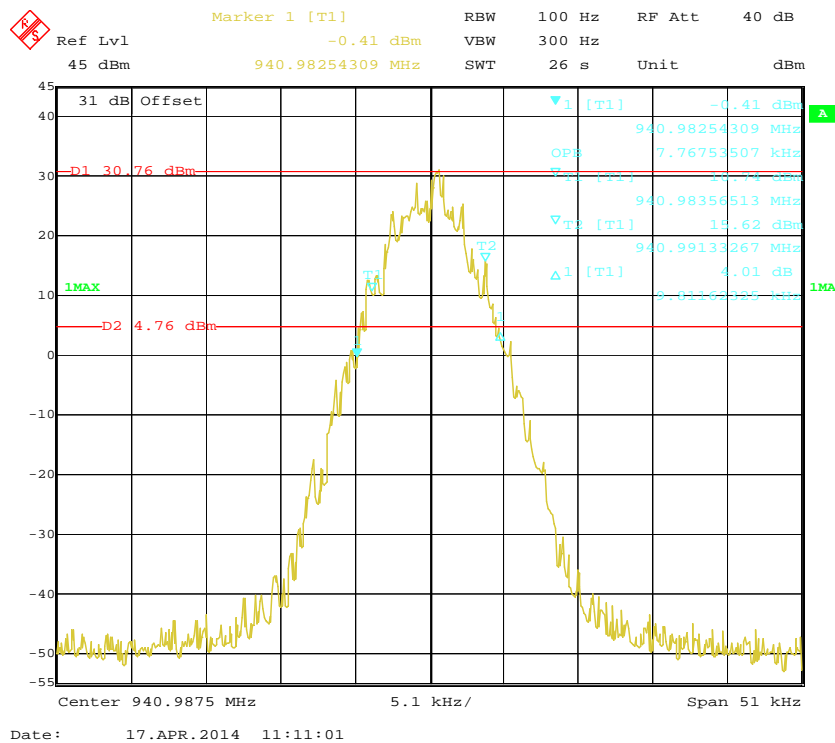

940.9875 MHz: Emission Mask with High Power

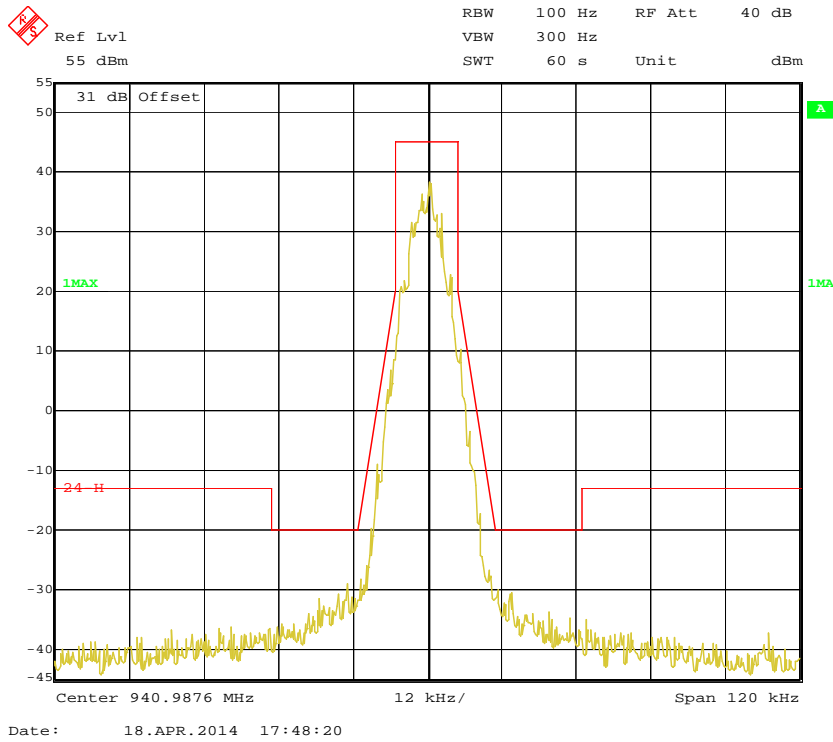

940.9875 MHz: Emission Mask with Low Power

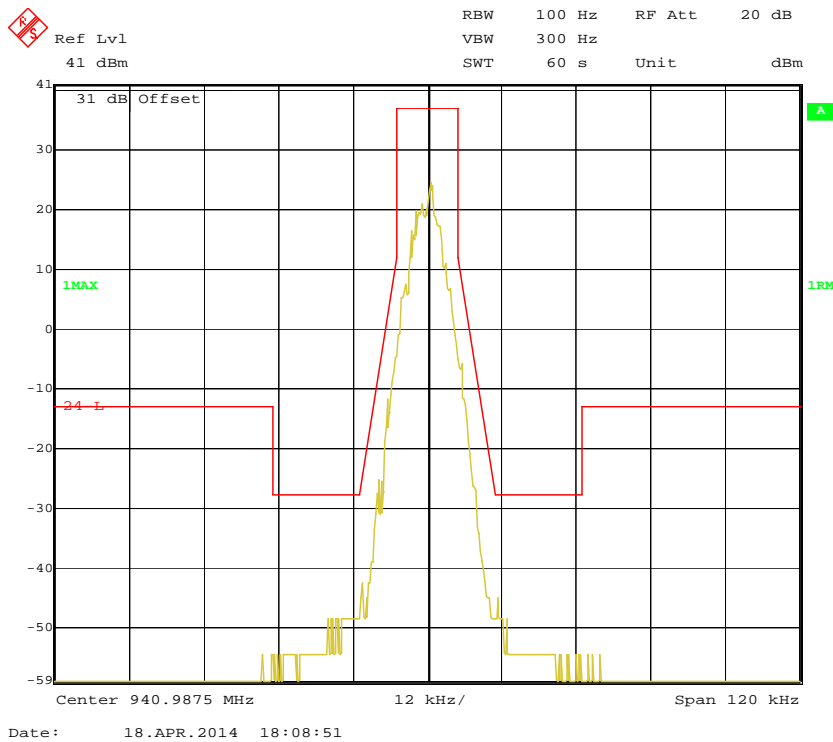

FCC §2.1051 & §90.210 - SPURIOUS EMISSIONS AT ANTENNA TERMINALS

Applicable Standard

Emission Mask B. For transmitters that are equipped with an audio low-pass filter, the power of any emission must be attenuated below the unmodulated carrier power (P) as follows:

- (1) On any frequency removed from the assigned frequency by more than 50 percent, but not more than 100 percent of the authorized bandwidth: At least 25 dB.
- (2) On any frequency removed from the assigned frequency by more than 100 percent, but not more than 250 percent of the authorized bandwidth: At least 35 dB.
- (3) On any frequency removed from the assigned frequency by more than 250 percent of the authorized bandwidth: At least $43 + 10 \log (P)$ dB.

Emission Mask I. For transmitters that are equipped with an audio low pass filter, the power of any emission must be attenuated below the unmodulated carrier power of the transmitter (P) as follows:

- (1) On any frequency removed from the center of the authorized bandwidth by a displacement frequency of more than 6.8 kHz, but no more than 9.0 kHz: At least 25 dB;
- (2) On any frequency removed from the center of the authorized bandwidth by a displacement frequency of more than 9.0 kHz, but no more than 15 kHz: At least 35 dB;
- (3) On any frequency removed from the center of the authorized bandwidth by a displacement frequency of more than 15 kHz: At least $43 + 10 \log (P)$ dB, or 70 dB, whichever is the lesser attenuation.

Test Equipment List and Details

Manufacturer	Description	Model No.	Serial No.	Calibration Date	Calibration Due Date
Rohde & Schwarz	Signal Analyzer	FSIQ26	8386001028	2013-11-12	2014-11-12

* **Statement of Traceability:** Bay Area Compliance Laboratories Corp. (Shenzhen) attests that all calibrations have been performed in accordance to requirements, traceable to National Primary Standards and International System of Units (SI).

Test Procedure

The RF output of the EUT was connected to a spectrum analyzer through appropriate attenuation. The resolution bandwidth of the spectrum analyzer was set at 100kHz for below 1GHz, and 1MHz for above 1GHz. Sufficient scans were taken to show any out of band emissions up to 10th harmonic.

Test Data

Environmental Conditions

Temperature:	20 ~ 25 °C
Relative Humidity:	50 ~ 56 %
ATM Pressure:	101.0 kPa

The testing was performed by Candy Li on 2014-03-05 to 2014-04-17.

Test Mode: Transmitting

Analog Modulation:

851.0125 MHz: 30 MHz – 1 GHz, Spacing Channel 12.5 kHz

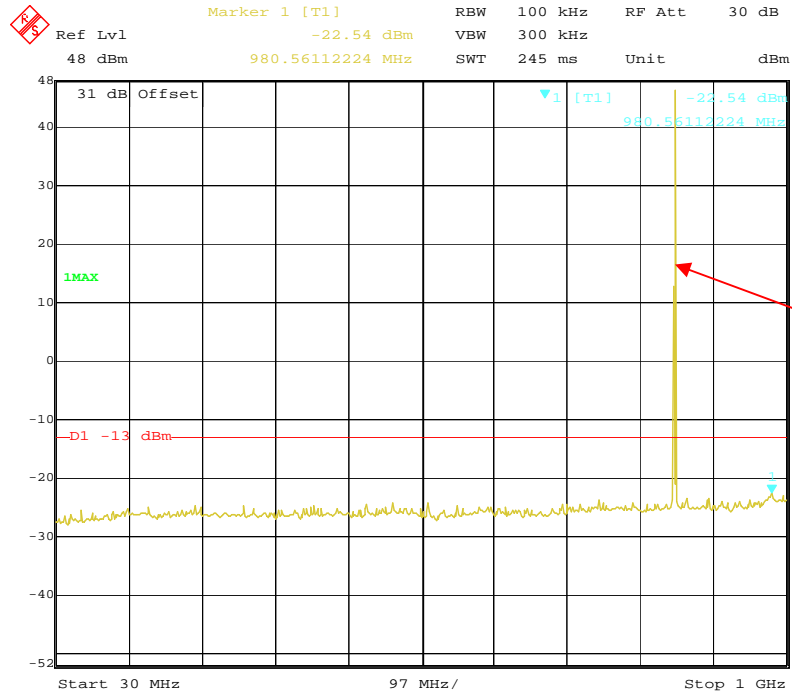

Date: 5.MAR.2014 09:20:11

851.0125 MHz: 1 GHz – 10 GHz, Spacing Channel 12.5 kHz

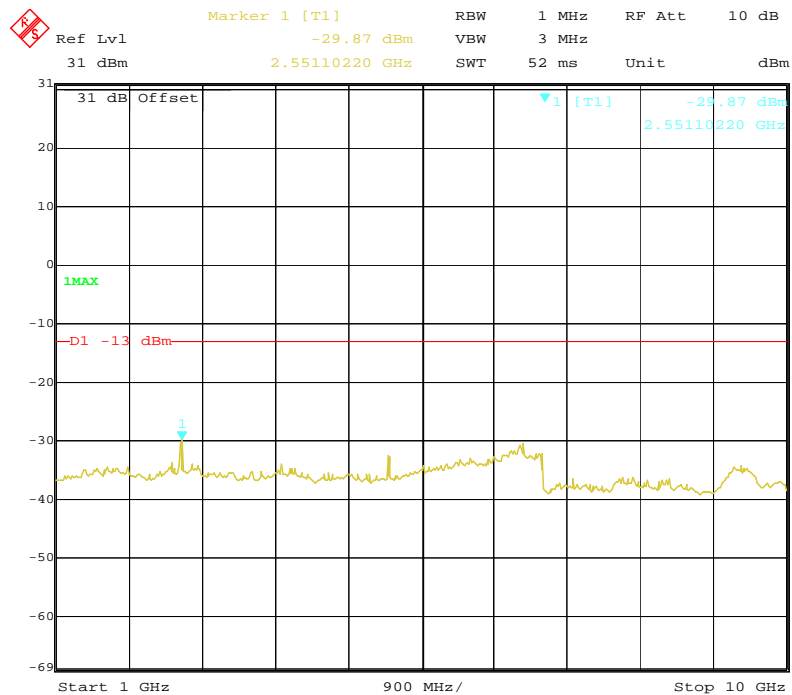

Date: 5.MAR.2014 10:48:24

868.9875 MHz: 30 MHz – 1 GHz, Spacing Channel 12.5 kHz

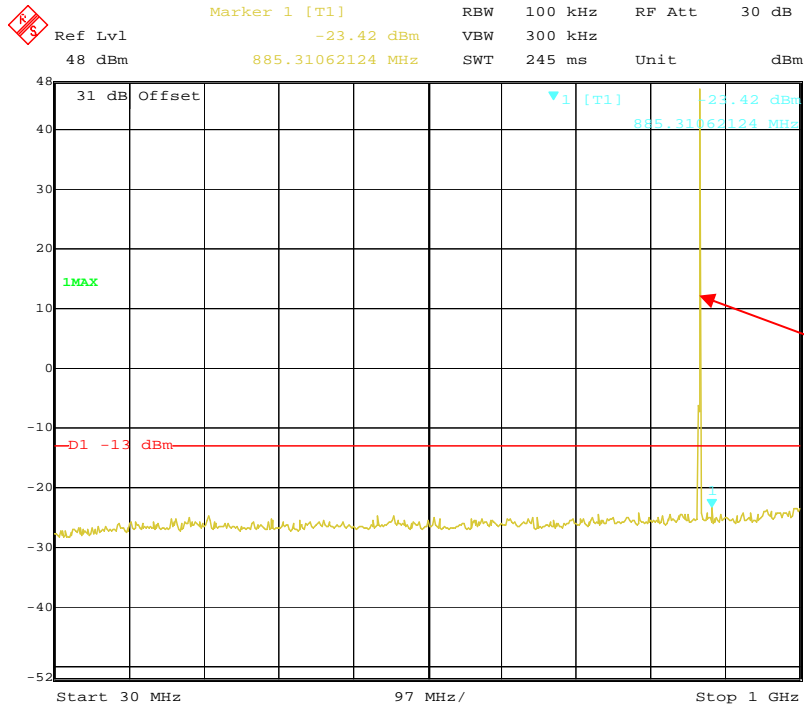

Date: 5.MAR.2014 09:20:54

868.9875 MHz: 1 GHz – 10 GHz, Spacing Channel 12.5 kHz

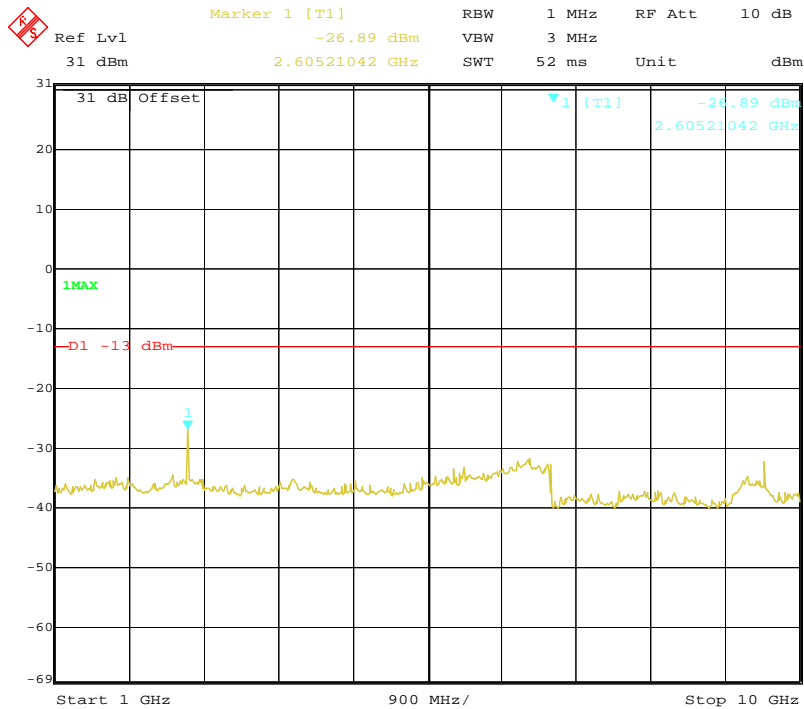

Date: 5.MAR.2014 10:48:57

939.9875MHz: 30 MHz – 1 GHz, Spacing Channel 12.5 kHz

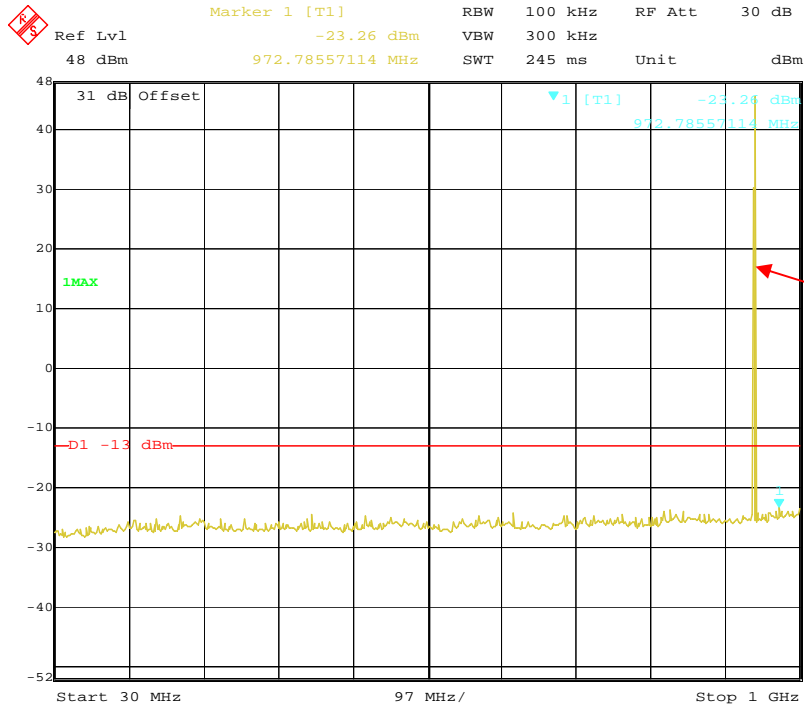

Fund.test with notch filter

Date: 5.MAR.2014 09:25:23

939.9875 MHz: 1 GHz – 10 GHz, Spacing Channel 12.5 kHz

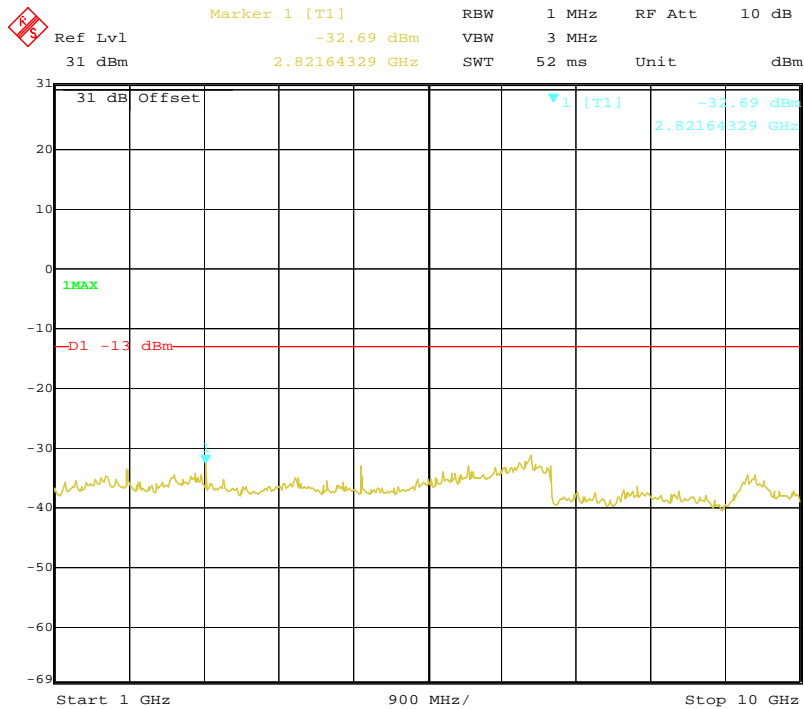

Date: 5.MAR.2014 10:52:50

940.9875MHz: 30 MHz – 1 GHz, Spacing Channel 12.5 kHz

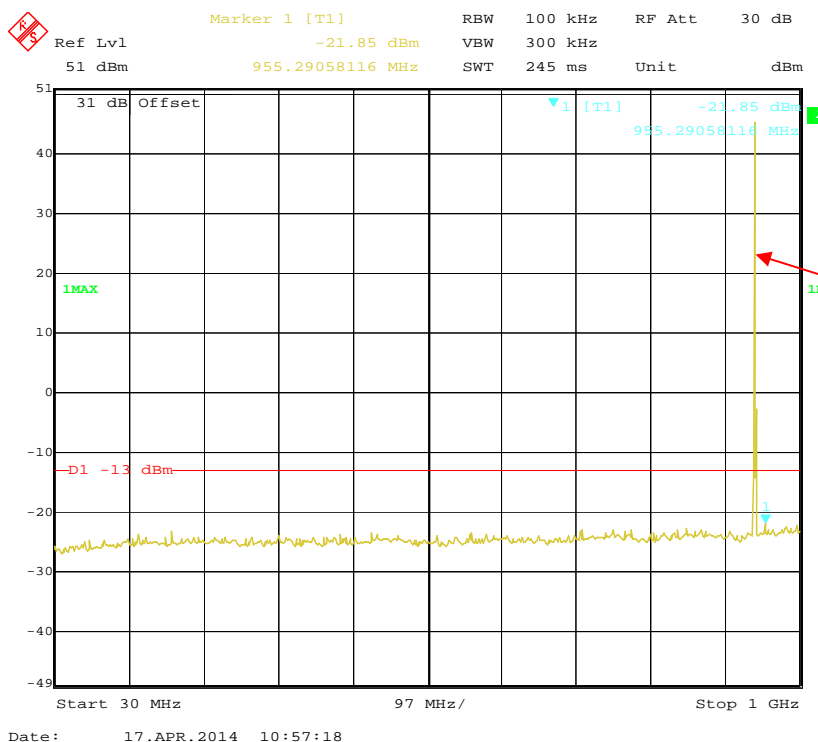

Fund.test with notch filter

940.9875 MHz: 1 GHz – 10 GHz, Spacing Channel 12.5 kHz

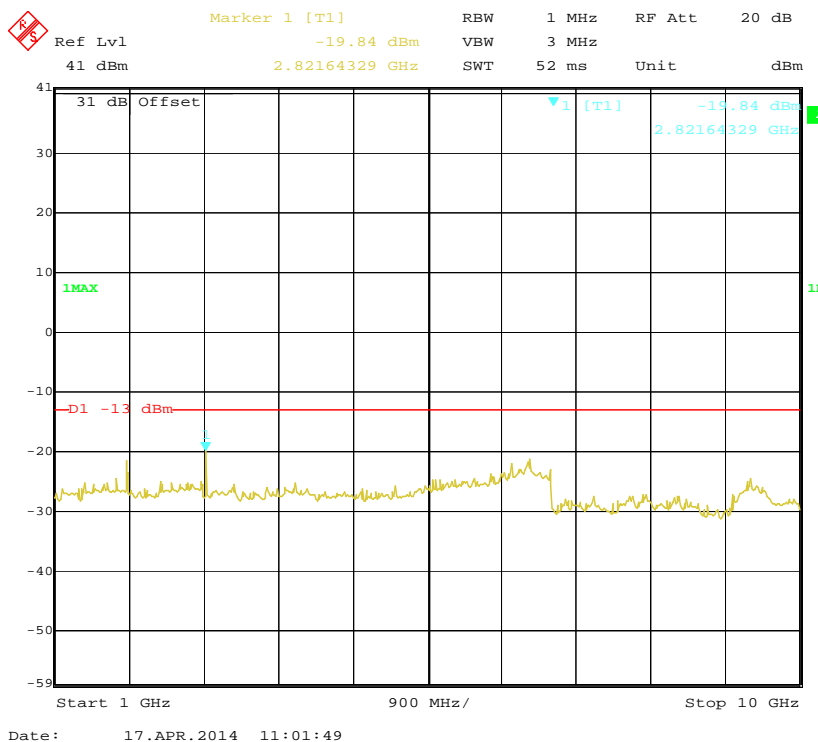

Digital Modulation:

851.0125 MHz: 30 MHz – 1 GHz

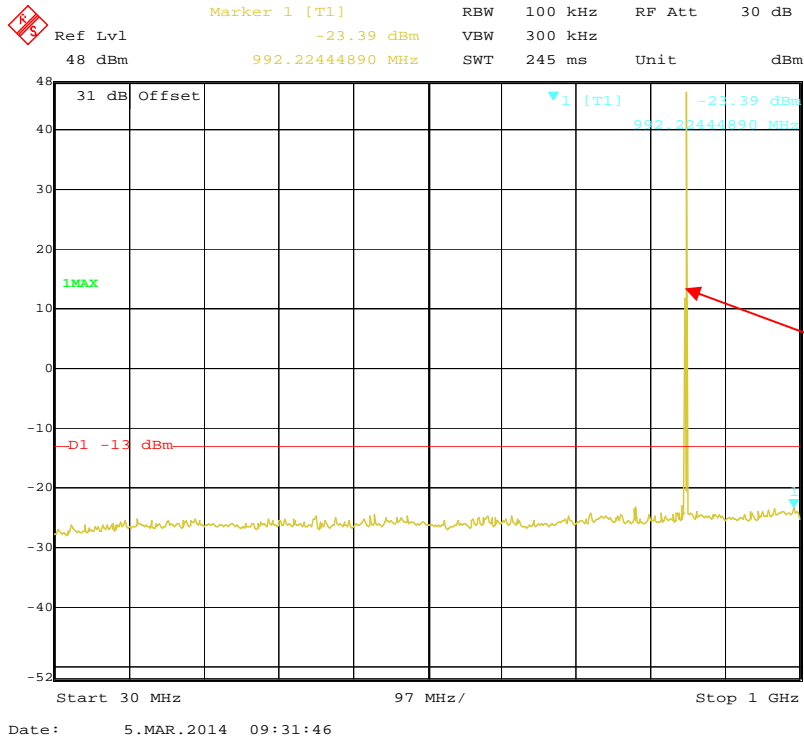

Fund.test with notch filter

851.0125 MHz: 1 GHz – 10 GHz

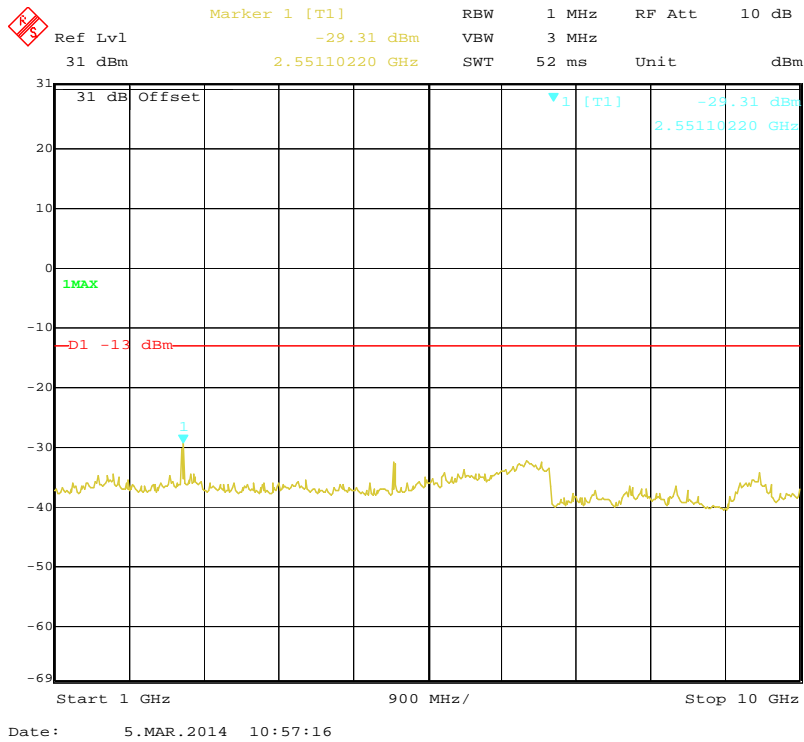

868.9875 MHz: 30 MHz – 1 GHz

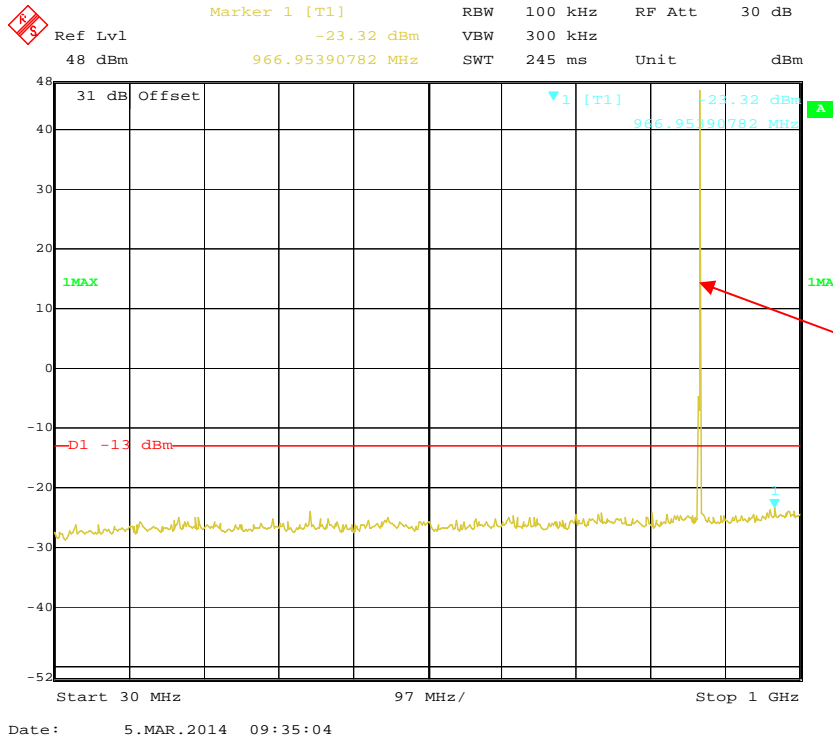

Fund.test with notch filter

868.9875 MHz: 1 GHz – 10 GHz

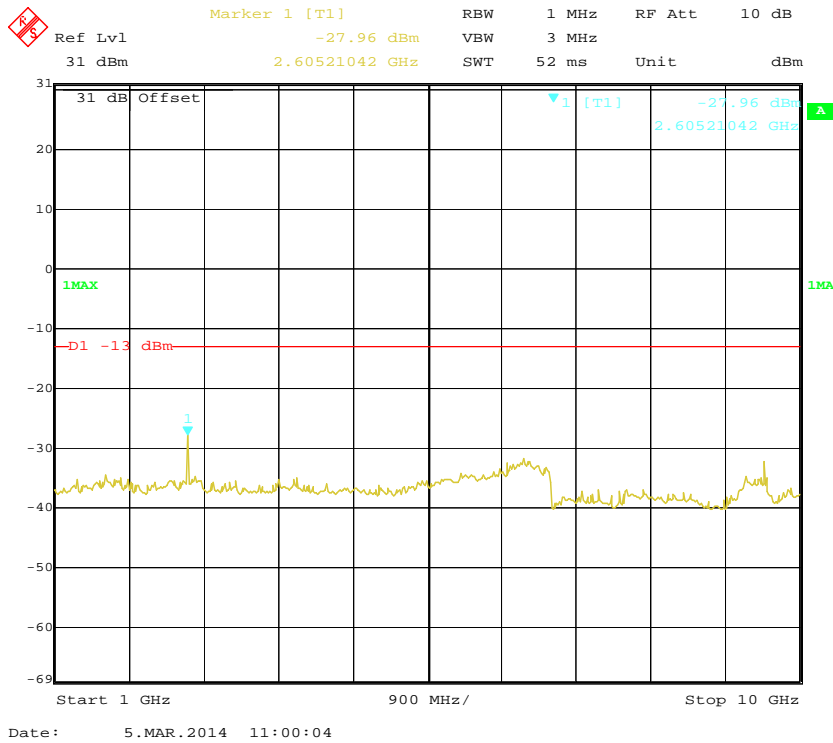

939.9875 MHz: 30 MHz – 1 GHz

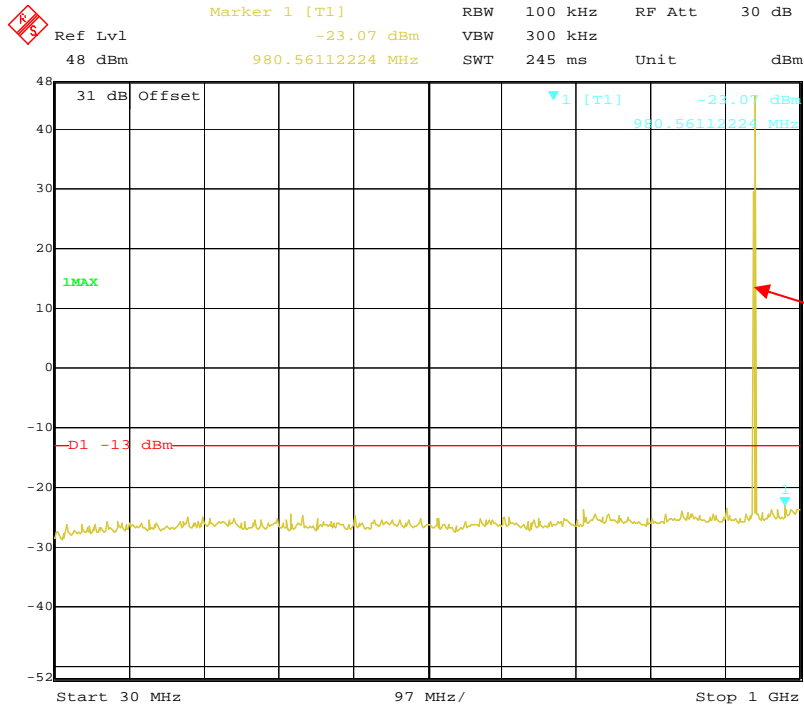

Date: 5.MAR.2014 09:38:20

939.9875 MHz: 1 GHz – 10 GHz

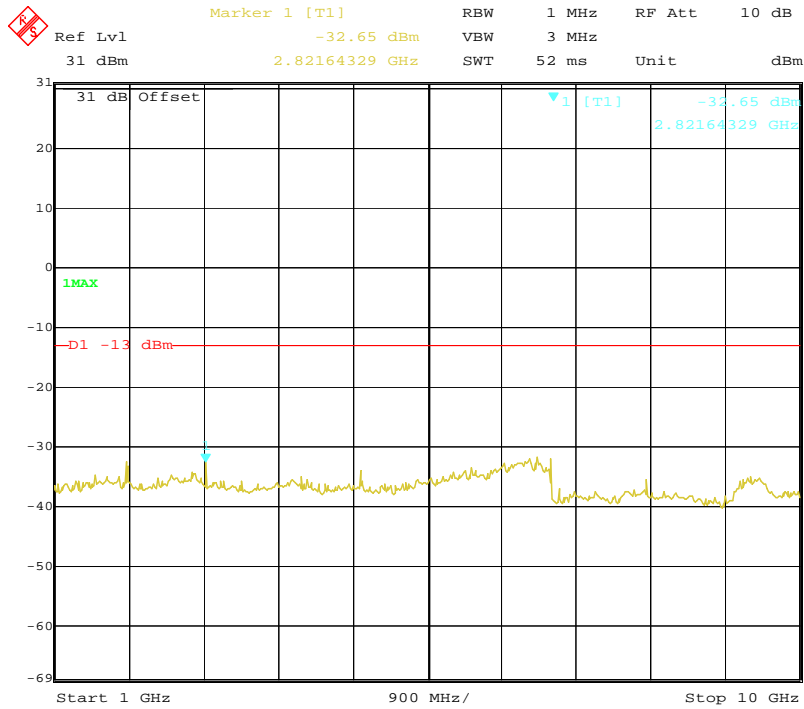

Date: 5.MAR.2014 11:03:56

940.9875 MHz: 30 MHz – 1 GHz

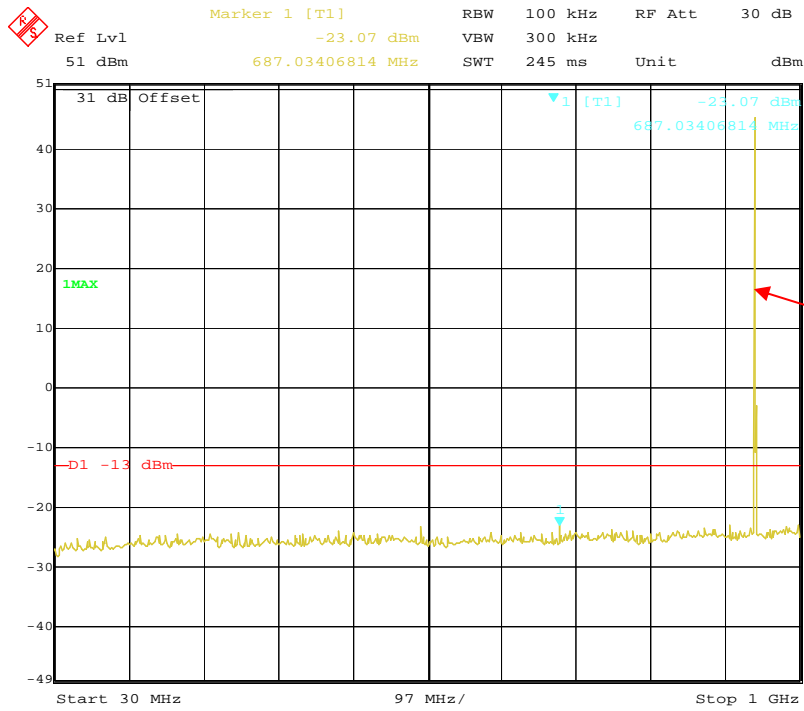

Date: 17.APR.2014 10:59:27

Fund.test with notch filter

940.9875 MHz: 1 GHz – 10 GHz

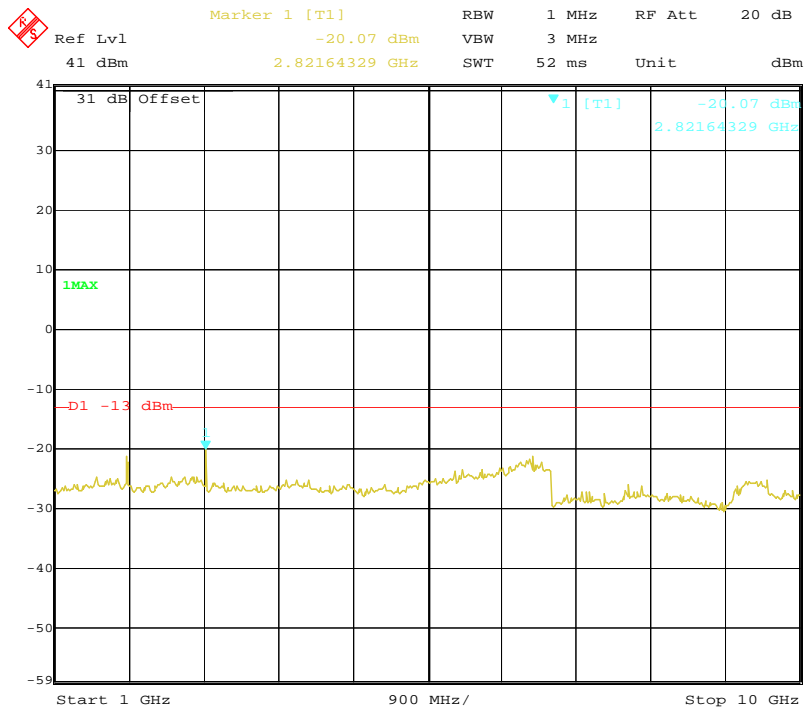

Date: 17.APR.2014 11:01:08

FCC §2.1053 & §90.210 - RADIATED SPURIOUS EMISSIONS

Applicable Standard

FCC §2.1053, §90.210

Test Equipment List and Details

Manufacturer	Description	Model No.	Serial No.	Calibration Date	Calibration Due Date
Sunol Sciences	Horn Antenna	DRH-118	A052304	2011-12-01	2014-11-30
Sunol Sciences	Broadband Antenna	JB1	A040904-2	2011-11-28	2014-11-27
Rohde & Schwarz	Signal Analyzer	FSIQ26	8386001028	2013-11-12	2014-11-12
Rohde & Schwarz	EMI Test Receiver	ESCI	101122	2013-09-25	2014-09-25
HP	Amplifier	8447E	1937A01046	2013-09-30	2014-09-30
Mini	Amplifier	ZVA-183-S+	5969001149	2014-04-03	2015-04-03
HP	Signal Generator	8657A	3217A04699	2013-12-19	2014-12-18
A.H. System	Horn Antenna	SAS-200/571	135	2012-02-11	2015-02-10
HP	Synthesized Sweeper	8341B	2624A00116	2013-05-09	2014-05-09
COM POWER	Dipole Antenna	AD-100	041000	NCR	NCR

* **Statement of Traceability:** Bay Area Compliance Laboratories Corp. (Shenzhen) attests that all calibrations have been performed in accordance to requirements, traceable to National Primary Standards and International System of Units (SI).

Test Procedure

The transmitter was placed on a wooden turntable, and it was transmitting into a non-radiating load, which was also placed on the turntable.

The measurement antenna was placed at a distance of 3 meters from the EUT. During the tests, the antenna height and polarization as well as EUT azimuth were varied in order to identify the maximum level of emissions from the EUT. The test was performed by placing the EUT on 3-orthogonal axis.

The frequency range up to teeth harmonic of the fundamental frequency was investigated.

Remove the EUT and replace it with substitution antenna. A signal generator was connected to the substitution antenna by a non-radiating cable. The absolute levels of the spurious emissions were measured by the substitution.

Spurious emissions in dB = 10 lg (TXpwr in Watts/0.001)-the absolute level

Spurious attenuation limit in dB = 50 + 10 Log₁₀ (power out in Watts) for EUT with a 12.5 kHz channel bandwidth.

Test Data

Environmental Conditions

Temperature:	20 ~ 26 °C
Relative Humidity:	48 ~ 56 %
ATM Pressure:	101.0 kPa

The testing was performed by Candy Li on 2014-02-13 to 2014-04-17.

Test Mode: Transmitting

30MHz - 10GHz:

Frequency (MHz)	Receiver Reading (dBµV)	Turn Table Angle Degree	Rx Antenna		Substituted			Absolute Level (dBm)	FCC Part 90	
			Height (m)	Polar (H/V)	SG Level (dBm)	Cable Loss (dB)	Antenna Gain (dB)		Limit (dBm)	Margin (dB)
Analog Modulation (851.0125MHz), Channel Spacing 12.5 kHz										
60.33	33.24	240	1.8	H	-63.6	0.24	0	-63.84	-13	50.84
60.33	31.83	139	1.5	V	-65.0	0.24	0	-65.24	-13	52.24
1702.0	53.05	66	1.8	H	-50.0	0.97	9.40	-41.57	-13	28.57
1702.0	53.34	40	1.8	V	-47.1	0.97	9.40	-38.67	-13	25.67
2553.0	58.65	132	2.1	H	-39.9	1.47	10.80	-30.57	-13	17.57
2553.0	55.41	177	1.6	V	-38.8	1.47	10.80	-29.47	-13	16.47
Analog Modulation (868.9875 MHz), Channel Spacing 12.5 kHz										
60.33	32.76	359	1.7	H	-64.0	0.24	0	-64.24	-13	51.24
60.33	31.59	75	1.8	V	-65.2	0.24	0	-65.44	-13	52.44
1738.0	53.05	146	1.2	H	-50.0	0.97	9.40	-41.57	-13	28.57
1738.0	54.41	266	1.6	V	-46.0	0.97	9.40	-37.57	-13	24.57
2607.0	41.43	233	1.6	H	-57.1	1.47	10.80	-47.77	-13	34.77
2607.0	44.92	47	1.2	V	-49.3	1.47	10.80	-39.97	-13	26.97
Analog Modulation (935.0125 MHz), Channel Spacing 12.5 kHz										
60.33	32.78	334	1.8	H	-64.0	0.24	0	-64.24	-13	51.24
60.33	32.34	220	1.6	V	-64.5	0.24	0	-64.74	-13	51.74
1870.0	56.24	287	1.5	H	-42.5	1.03	9.40	-34.13	-13	21.13
1870.0	55.19	255	2.1	V	-43.4	1.03	9.40	-35.03	-13	22.03
2805.0	45.66	321	1.8	H	-51.5	1.59	10.80	-42.29	-13	29.29
2805.0	50.96	39	1.6	V	-44.1	1.59	10.80	-34.89	-13	21.89
Analog Modulation (939.9875 MHz), Channel Spacing 12.5 kHz										
60.33	33.64	124	1.5	H	-63.2	0.24	0	-63.44	-13	50.44
60.33	31.20	252	1.3	V	-65.6	0.24	0	-65.84	-13	52.84
1880.0	52.71	100	2.3	H	-46.0	1.03	9.40	-37.63	-13	24.63
1880.0	53.37	1	1.6	V	-45.2	1.03	9.40	-36.83	-13	23.83
2820.0	46.67	220	1.0	H	-50.5	1.59	10.80	-41.29	-13	28.29
2820.0	50.32	101	2.5	V	-44.7	1.59	10.80	-35.49	-13	22.49

Frequency (MHz)	Receiver Reading (dBµV)	Turn Table Angle Degree	Rx Antenna		Substituted			Absolute Level (dBm)	FCC Part 90	
			Height (m)	Polar (H/V)	SG Level (dBm)	Cable Loss (dB)	Antenna Gain (dB)		Limit (dBm)	Margin (dB)
Analog Modulation (940.9875 MHz), Channel Spacing 12.5 kHz										
60.33	33.61	139	1.4	H	-63.2	0.24	0	-63.44	-13	50.44
60.33	31.58	109	1.7	V	-65.2	0.24	0	-65.44	-13	52.44
1882.0	54.50	233	1.1	H	-44.3	1.03	9.40	-35.93	-13	22.93
1882.0	51.01	244	1.1	V	-47.6	1.03	9.40	-39.23	-13	26.23
2823.0	51.42	201	1.0	H	-45.7	1.59	10.80	-36.49	-13	23.49
2823.0	53.81	74	1.1	V	-41.2	1.59	10.80	-31.99	-13	18.99
Digital Modulation (851.0125MHz), Channel Spacing 12.5 kHz										
60.33	33.35	300	1.6	H	-63.5	0.24	0	-63.74	-13	50.74
60.33	32.46	327	1.5	V	-64.3	0.24	0	-64.54	-13	51.54
1702.0	54.01	106	2.4	H	-49.0	0.97	9.40	-40.57	-13	27.57
1702.0	52.85	141	1.8	V	-47.6	0.97	9.40	-39.17	-13	26.17
2553.0	56.99	347	2.2	H	-41.5	1.47	10.80	-32.17	-13	19.17
2553.0	55.67	18	1.7	V	-38.6	1.47	10.80	-29.27	-13	16.27
Digital Modulation (868.9875 MHz), Channel Spacing 12.5 kHz										
60.33	33.09	329	1.6	H	-63.7	0.24	0	-63.94	-13	50.94
60.33	32.21	214	1.5	V	-64.6	0.24	0	-64.84	-13	51.84
1738.0	53.09	16	1.1	H	-49.9	0.97	9.40	-41.47	-13	28.47
1738.0	53.01	60	1.4	V	-47.4	0.97	9.40	-38.97	-13	25.97
2607.0	45.03	234	2.4	H	-53.5	1.47	10.80	-44.17	-13	31.17
2607.0	45.16	2	2.4	V	-49.1	1.47	10.80	-39.77	-13	26.77
Digital Modulation (935.0125 MHz), Channel Spacing 12.5 kHz										
60.33	33.35	95	1.8	H	-63.5	0.24	0	-63.74	-13	50.74
60.33	31.62	118	1.3	V	-65.2	0.24	0	-65.44	-13	52.44
1870.0	55.59	352	2.3	H	-43.2	1.03	9.40	-34.83	-13	21.83
1870.0	53.42	349	2.2	V	-45.2	1.03	9.40	-36.83	-13	23.83
2805.0	47.72	289	2.2	H	-49.4	1.59	10.80	-40.19	-13	27.19
2805.0	50.62	329	1.3	V	-44.4	1.59	10.80	-35.19	-13	22.19
Digital Modulation (939.9875 MHz), Channel Spacing 12.5 kHz										
60.33	33.47	355	1.4	H	-63.3	0.24	0	-63.54	-13	50.54
60.33	31.42	344	1.9	V	-65.4	0.24	0	-65.64	-13	52.64
1880.0	55.48	348	2.0	H	-43.3	1.03	9.40	-34.93	-13	21.93
1880.0	53.01	326	1.3	V	-45.6	1.03	9.40	-37.23	-13	24.23
2820.0	50.31	67	2.1	H	-46.8	1.59	10.80	-37.59	-13	24.59
2820.0	53.14	110	1.0	V	-41.9	1.59	10.80	-32.69	-13	19.69

Frequency (MHz)	Receiver Reading (dBμV)	Turn Table Angle Degree	Rx Antenna		Substituted			Absolute Level (dBm)	FCC Part 90	
			Height (m)	Polar (H/V)	SG Level (dBm)	Cable Loss (dB)	Antenna Gain (dB)		Limit (dBm)	Margin (dB)
Digital Modulation (940.9875 MHz), Channel Spacing 12.5 kHz										
60.33	33.14	199	1.5	H	-63.7	0.24	0	-63.94	-13	50.94
60.33	31.80	147	1.8	V	-65.0	0.24	0	-65.24	-13	52.24
1882.0	54.22	22	1.8	H	-44.5	1.03	9.40	-36.13	-13	23.13
1882.0	51.92	21	1.7	V	-46.7	1.03	9.40	-38.33	-13	25.33
2823.0	51.39	357	1.4	H	-45.8	1.59	10.80	-36.59	-13	23.59
2823.0	53.68	353	1.1	V	-41.4	1.59	10.80	-32.19	-13	19.19

Note:

Absolute Level = SG Level - Cable loss + Antenna Gain

Margin = Limit - Absolute Level

FCC §2.1055 & §90.213- FREQUENCY STABILITY

Applicable Standard

FCC §2.1055, §90.213

Test Equipment List and Details

Manufacturer	Description	Model No.	Serial No.	Calibration Date	Calibration Due Date
Hewlett-Packard	Frequency Counter	5343A	2232A00827	2013-05-09	2014-05-09
ESPEC	Temperature & Humidity Chamber	EL-10KA	09107726	2013-11-01	2014-11-01

* **Statement of Traceability:** Bay Area Compliance Laboratories Corp. (Shenzhen) attests that all calibrations have been performed in accordance to requirements, traceable to National Primary Standards and International System of Units (SI).

Test Procedure

Frequency Stability vs. Temperature: The equipment under test was connected to an external DC power supply and the RF output was connected to a frequency counter via feed-through attenuators. The EUT was placed inside the temperature chamber. The DC leads and RF output cable exited the chamber through an opening made for the purpose.

After the temperature stabilized for approximately 20 minutes, the frequency output was recorded from the counter.

Test Data

Environmental Conditions

Temperature:	20 ~ 25 °C
Relative Humidity:	48 ~ 56 %
ATM Pressure:	101.0 kPa

The testing was performed by Candy Li from 2014-04-11 to 2014-04-17.

Test Mode: Transmitting

Analog Modulation:

Reference Frequency: 851.0125 MHz, Limit: 1.0 ppm, Channel Spacing: 12.5 kHz			
Test Environment		Frequency Measure with Time Elapsed	
Temperature (°C)	Power Supplied (V_{DC})	Measured Frequency error (MHz)	Frequency Error (ppm)
Frequency Stability versus Input Temperature			
50	13.6	851.012465	-0.041
40	13.6	851.012454	-0.054
30	13.6	851.012472	-0.033
20	13.6	851.012466	-0.040
10	13.6	851.012483	-0.020
0	13.6	851.012452	-0.056
-10	13.6	851.012465	-0.041
-20	13.6	851.012473	-0.032
-30	13.6	851.012456	-0.052
Frequency Stability versus Input Voltage			
20	11.0	851.012471	-0.034

Reference Frequency: 868.9875 MHz, Limit: 1.5 ppm, Channel Spacing: 12.5 kHz			
Test Environment		Frequency Measure with Time Elapsed	
Temperature (°C)	Power Supplied (V_{DC})	Measured Frequency error (MHz)	Frequency Error (ppm)
Frequency Stability versus Input Temperature			
50	13.6	868.987444	-0.064
40	13.6	868.987451	-0.056
30	13.6	868.987448	-0.060
20	13.6	868.987449	-0.059
10	13.6	868.987447	-0.061
0	13.6	868.987443	-0.066
-10	13.6	868.987445	-0.063
-20	13.6	868.987447	-0.061
-30	13.6	868.987446	-0.062
Frequency Stability versus Input Voltage			
20	11.0	868.987445	-0.063

Reference Frequency: 939.9875 MHz, Limit: 0.1 ppm, Channel Spacing: 12.5 kHz			
Test Environment		Frequency Measure with Time Elapsed	
Temperature (°C)	Power Supplied (V_{DC})	Measured Frequency error (MHz)	Frequency Error (ppm)
Frequency Stability versus Input Temperature			
50	13.6	939.987438	-0.066
40	13.6	939.987442	-0.062
30	13.6	939.987439	-0.065
20	13.6	939.987436	-0.068
10	13.6	939.987440	-0.064
0	13.6	939.987439	-0.065
-10	13.6	939.987437	-0.067
-20	13.6	939.987435	-0.069
-30	13.6	939.987439	-0.065
Frequency Stability versus Input Voltage			
20	11.0	939.987436	-0.068

Reference Frequency: 940.9875 MHz, Limit: 1.0 ppm, Channel Spacing: 12.5 kHz			
Test Environment		Frequency Measure with Time Elapsed	
Temperature (°C)	Power Supplied (V_{DC})	Measured Frequency error (MHz)	Frequency Error (ppm)
Frequency Stability versus Input Temperature			
50	13.6	940.987466	-0.036
40	13.6	940.987462	-0.040
30	13.6	940.987465	-0.037
20	13.6	940.987459	-0.044
10	13.6	940.987461	-0.041
0	13.6	940.987462	-0.040
-10	13.6	940.987467	-0.035
-20	13.6	940.987463	-0.039
-30	13.6	940.987460	-0.043
Frequency Stability versus Input Voltage			
20	11.0	940.987465	-0.037

Digital Modulation:

Reference Frequency: 851.0125 MHz, Limit: 1.0 ppm, Channel Spacing: 12.5 kHz			
Test Environment		Frequency Measure with Time Elapsed	
Temperature (°C)	Power Supplied (V_{DC})	Measured Frequency error (MHz)	Frequency Error (ppm)
Frequency Stability versus Input Temperature			
50	13.6	851.012462	-0.045
40	13.6	851.012459	-0.048
30	13.6	851.012464	-0.042
20	13.6	851.012465	-0.041
10	13.6	851.012457	-0.051
0	13.6	851.012458	-0.049
-10	13.6	851.012461	-0.046
-20	13.6	851.012463	-0.043
-30	13.6	851.012456	-0.052
Frequency Stability versus Input Voltage			
20	11.0	851.01246	-0.047

Reference Frequency: 868.9875 MHz, Limit: 1.5 ppm, Channel Spacing: 12.5 kHz			
Test Environment		Frequency Measure with Time Elapsed	
Temperature (°C)	Power Supplied (V_{DC})	Measured Frequency error (MHz)	Frequency Error (ppm)
Frequency Stability versus Input Temperature			
50	13.6	868.987453	-0.054
40	13.6	868.987456	-0.051
30	13.6	868.987450	-0.058
20	13.6	868.987448	-0.060
10	13.6	868.987452	-0.055
0	13.6	868.987450	-0.058
-10	13.6	868.987451	-0.056
-20	13.6	868.987449	-0.059
-30	13.6	868.987455	-0.052
Frequency Stability versus Input Voltage			
20	11.0	868.987452	-0.055

Reference Frequency: 939.9875 MHz, Limit: 0.1 ppm, Channel Spacing: 12.5 kHz			
Test Environment		Frequency Measure with Time Elapsed	
Temperature (°C)	Power Supplied (V_{DC})	Measured Frequency error (MHz)	Frequency Error (ppm)
Frequency Stability versus Input Temperature			
50	13.6	939.987461	-0.041
40	13.6	939.987458	-0.045
30	13.6	939.987460	-0.043
20	13.6	939.987464	-0.038
10	13.6	939.987459	-0.044
0	13.6	939.987458	-0.045
-10	13.6	939.987463	-0.039
-20	13.6	939.987462	-0.040
-30	13.6	939.987465	-0.037
Frequency Stability versus Input Voltage			
20	11.0	939.987462	-0.040

Reference Frequency: 940.9875 MHz, Limit: 1.0 ppm, Channel Spacing: 12.5 kHz			
Test Environment		Frequency Measure with Time Elapsed	
Temperature (°C)	Power Supplied (V_{DC})	Measured Frequency error (MHz)	Frequency Error (ppm)
Frequency Stability versus Input Temperature			
50	13.6	940.987471	-0.031
40	13.6	940.987468	-0.034
30	13.6	940.987469	-0.033
20	13.6	940.987470	-0.032
10	13.6	940.987473	-0.029
0	13.6	940.987472	-0.030
-10	13.6	940.987475	-0.027
-20	13.6	940.987467	-0.035
-30	13.6	940.987474	-0.028
Frequency Stability versus Input Voltage			
20	11.0	940.987472	-0.030

PRODUCT SIMILARITY DECLARATION LETTER



Hytera Communications Co.,Ltd.

HYT Tower, Hi-Tech Industrial Park North, Nanshan District, Shenzhen China

Tel: +86-0755-26972999- 1210 Fax: 0755-86137130

2014-4-17

Product Similarity Declaration

To Whom It May Concern,

We, Hytera Communications Corporation Ltd., hereby declare that our Digital Base Station Repeater, Model Number: RD980S U(5), RD985S U(5), RD986S U(5), RD988S U(5) are electrically identical with RD982S U(5) that was certified by BACL. There are named differently due to market purpose.

Please contact me if you have any question.

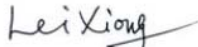
Signature: 

Lei Xiong
General Director

******* END OF REPORT *******