



TEST REPORT

FCC Part 90

Report Reference No......: **TRE12120130 R/C: 24373**

FCC ID.....: **YAMRD96XU1**

Compiled by
 (position+printed name+signature)..: File administrators Tim Zhang

Tim Zhang

Supervised by
 (position+printed name+signature)..: Test Engineer Eric Zhang

Eric Zhang

Approved by
 (position+printed name+signature)..: Manager Wenliang Li

Wenliang Li

Date of issue.....: Mar 01, 2013

Testing Laboratory Name: **Shenzhen Huatongwei International Inspection Co., Ltd**

Address.....: Keji Nan No.12 Road, Hi-tech Park, Shenzhen, China

Applicant's name.....: **Hytera Communications Corporation Ltd.**

Address.....: HYT Tower,Hi-Tech Industrial Park North,Nanshan District,Shenzhen China.518057

Test specification:

Standard: **FCC Part 90: PRIVATE LAND MOBILE RADIO SERVICES**

TRF Originator.....: Shenzhen Huatongwei International Inspection CO., Ltd

Master TRF.....: Dated 2006-06

Shenzhen Huatongwei International Inspection Co., Ltd. All rights reserved.

This publication may be reproduced in whole or in part for non-commercial purposes as long as the Shenzhen Huatongwei International Inspection Co., Ltd is acknowledged as copyright owner and source of the material. Shenzhen Huatongwei International Inspection Co., Ltd takes no responsibility for and will not assume liability for damages resulting from the reader's interpretation of the reproduced material due to its placement and context.

Test item description: Digital Portable Repeater

Trade Mark: 

Manufacturer: **Hytera Communications Corporation Ltd.**

Model/Type reference.....: RD962 U(1)/ RD965 U(1)/ RD966 U(1)/ RD968 U(1)

Listed Models: /

Ratings.....: DC 13.6V

Modulation: FM&4FSK

Channel Separation.....: 12.5KHz

Rated Power: 10 Watts(40.00dBm)/1 Watts(30.00dBm)

Operation Frequency Range: From 400 MHz to 470 MHz

Result.....: **Positive**

TEST REPORT

Test Report No. :	TRE12120130	Mar 01, 2013
		Date of issue

Equipment under Test : Digital Portable Repeater

Model /Type : RD962 U(1)/ RD965 U(1)/ RD966 U(1)/ RD968 U(1)

Listed Models : /

Applicant : **Hytera Communications Corporation Ltd.**

Address : HYT Tower,Hi-Tech Industrial Park North,Nanshan District,Shenzhen China.518057

Manufacturer : **Hytera Communications Corporation Ltd.**

Address : HYT Tower,Hi-Tech Industrial Park North,Nanshan District,Shenzhen China.518057

Test Result according to the standards on page 4:	Positive
--	-----------------

The test report merely corresponds to the test sample.
 It is not permitted to copy extracts of these test result without the written permission of the test laboratory.

Contents

1.	<u>TEST STANDARDS</u>	4
2.	<u>SUMMARY</u>	5
2.1.	General Remarks	5
2.2.	Product Description	5
2.3.	Equipment under Test	5
2.4.	Short description of the Equipment under Test (EUT)	6
2.5.	EUT Configuration	6
2.6.	EUT operation mode	6
2.7.	EUT configuration	6
2.8.	Related Submittal(s) / Grant (s)	6
2.9.	Modifications	7
2.10.	Note	7
3.	<u>TEST ENVIRONMENT</u>	8
3.1.	Address of the test laboratory	8
3.2.	Test Facility	8
3.3.	Environmental conditions	9
3.4.	Configuration of Tested System	9
3.5.	Discription of Tested Modes	9
3.6.	Statement of the measurement uncertainty	9
3.7.	Test Description	10
3.8.	Equipments Used during the Test	10
4.	<u>TEST CONDITIONS AND RESULTS</u>	13
4.1.	Conducted Emissions Test	13
4.2.	Occupied Bandwidth and Emission Mask Test	18
4.3.	Transmitter Radiated Spurious Emssion	47
4.4.	Spurious Emssion on Antenna Port	54
4.5.	Modulation Charcateristics	81
4.6.	Frequency Stability Test	84
4.7.	Maximum Transmitter Power	86
4.8.	Transmitter Frequency Behavior	97
4.9.	Receiver Radiated Spurious Emssion	100
4.10.	Receiver Conducted Spurious Emssion	110
5.	<u>TEST SETUP PHOTOS OF THE EUT</u>	121
6.	<u>EXTERNAL AND INTERNAL PHOTOS OF THE EUT</u>	126

1. TEST STANDARDS

The tests were performed according to following standards:

FCC Rules Part 90: PRIVATE LAND MOBILE RADIO SERVICES.

TIA/EIA 603 D June 2010: Land Mobile FM or PM Communications Equipment Measurement and Performance Standards.

47 CFR FCC Part 15 Subpart B - Unintentional Radiators

FCC Part 2: FREQUENCY ALLOCATIONS AND RADIO TREATY MATTERS; GENERAL RULES AND REGULATIONS

2. SUMMARY

2.1. General Remarks

Date of receipt of test sample	:	Dec 30, 2012
Testing commenced on	:	Dec 30, 2012
Testing concluded on	:	Mar 01, 2013

2.2. Product Description

The Hytera Communications Corporation Ltd.'s Model: RD962 U(1)/ RD965 U(1)/ RD966 U(1)/ RD968 U(1) or the "EUT" as referred to in this report; more general information as follows, for more details, refer to the user's manual of the EUT.

Name of EUT	Digital Portable Repeater	
Model Number	RD962 U(1)/ RD965 U(1)/ RD966 U(1)/ RD968 U(1)	
FCC ID	YAMRD96XU1	
Rated Output Power	10 Watts(40.00dBm)/1 Watts(30.00dBm)	
Support data rate	9.6kbps	
Modulation Type	FM for Analog Voice	
	4FSK for Digital Voice/Digital Data	
	4FSK for Digital Data	
	Analog	11K0F3E for 12.5KHz Channel Separation
Digital	7K60FXD for Digital Data only	
	7K60FXW for Digital Data & Digital Voice	
Channel Separation	Analog Voice	12.5KHz
	Digital Voice/Data	12.5KHz
	Digital Data	12.5KHz
Antenna Type	External	
Frequency Range	From 400 MHz to 470 MHz	
Maximum Transmitter Power	Analog	10.72W for 12.5 KHz Channel Separation
	Digital	10.99W for 12.5 KHz Channel Separation

Note: The product has the same digital working characters when operating in both two digitized voice/data mode (7K60FXD and 7K60FXW). So only one set of test results for digital modulation modes are provided in this test report.

2.3. Equipment under Test

Power supply system utilised

Power supply voltage	:	<input type="radio"/> 120V / 60 Hz	<input type="radio"/> 115V / 60Hz
		<input type="radio"/> 12 V DC	<input type="radio"/> 24 V DC
		<input checked="" type="radio"/> Other (specified in blank below)	

DC 13.6V

Test frequency list

Modulation Type	Test Channel	Test Frequency
Analog/FM	Low	406.5000 MHz
	Low	418.0000 MHz
	Middle	435.5000 MHz
	High	453.0000 MHz
	High	469.5000 MHz
Digital/4FSK	Low	406.5000 MHz
	Low	418.0000 MHz
	Middle	435.5000 MHz
	High	453.0000 MHz
	High	469.5000 MHz

2.4. Short description of the Equipment under Test (EUT)

400-470 MHz U frequency band Digital Portable Repeater with GPS function.

For more details, refer to the user's manual of the EUT.

Serial number: Prototype

2.5. EUT Configuration

The EUT configuration for testing is installed on RF field strength measurement to meet the Commission's requirement and operating in a manner which intends to maximize its emission characteristics in a continuous normal application.

2.6. EUT operation mode

The EUT has been tested under typical operating condition and The Transmitter was operated in the normal operating mode. The TX frequency was fixed which was for the purpose of the measurements.

2.7. EUT configuration

The following peripheral devices and interface cables were connected during the measurement:

● - supplied by the manufacturer

○ - supplied by the lab

<input type="radio"/>	Power Cable	Length (m) :	/
		Shield :	/
		Detachable :	/
<input type="radio"/>	Multimeter	Manufacturer :	/
		Model No. :	/

2.8. Related Submittal(s) / Grant (s)

This submittal(s) (test report) is intended for FCC ID: **YAMRD96XU1** filing to comply with FCC Part 90 Rules.

2.9. Modifications

No modifications were implemented to meet testing criteria.

2.10. Note

The EUT is a U frequency band (400-470MHz) Digital Portable Repeater with GPS function, The functions of the EUT listed as below:

	Test Standards	Reference Report
Radio	FCC Part 90	TRE12120130
EMF	OET 65C	TRE12120131

3. TEST ENVIRONMENT

3.1. Address of the test laboratory

Shenzhen Huatongwei International Inspection Co., Ltd
Keji Nan No.12 Road, Hi-tech Park, Shenzhen, China
Phone: 86-755-26715686 Fax: 86-755-26748089

The sites are constructed in conformance with the requirements of ANSI C63.7, ANSI C63.4 (2009) and CISPR Publication 22.

3.2. Test Facility

The test facility is recognized, certified, or accredited by the following organizations:

CNAS-Lab Code: L1225

Shenzhen Huatongwei International Inspection Co., Ltd. has been assessed and proved to be in compliance with CNAS-CL01 Accreditation Criteria for Testing and Calibration Laboratories (identical to ISO/IEC 17025: 2005 General Requirements) for the Competence of Testing and Calibration Laboratories, Date of Registration: Mar. 01, 2012. Valid time is until Feb. 28, 2015.

A2LA-Lab Cert. No. 2243.01

Shenzhen Huatongwei International Inspection Co., Ltd. EMC Laboratory has been accredited by A2LA for technical competence in the field of electrical testing, and proved to be in compliance with ISO/IEC 17025: 2005 General Requirements for the Competence of Testing and Calibration Laboratories and any additional program requirements in the identified field of testing. Valid time is until Sept. 30, 2013.

FCC-Registration No.: 662850

Shenzhen Huatongwei International Inspection Co., Ltd. EMC Laboratory has been registered and fully described in a report filed with the FCC (Federal Communications Commission). The acceptance letter from the FCC is maintained in our files. Registration 662850, Renewal date Jul. 01, 2009, valid time is until Jun. 30, 2015.

IC-Registration No.: 5377A

The 3m Alternate Test Site of Shenzhen Huatongwei International Inspection Co., Ltd. has been registered by Certification and Engineering Bureau of Industry Canada for the performance of radiated measurements with Registration No. 5377A on Jan. 25, 2011, valid time is until Jan. 24, 2014.

ACA

Shenzhen Huatongwei International Inspection Co., Ltd. EMC Laboratory can also perform testing for the Australian C-Tick mark as a result of our A2LA accreditation.

NEMKO-Aut. No.: ELA125

Shenzhen Huatongwei International Inspection Co., Ltd has been assessed the quality assurance system, the testing facilities, qualifications and testing practices of the relevant parts of the organization. The quality assurance system of the Laboratory has been validated against ISO/IEC 17025 or equivalent. The laboratory also fulfils the conditions described in Nemko Document NLA-10, the authorization is valid through July 07, 2013

VCCI

The 3m Semi-anechoic chamber (12.2m×7.95m×6.7m) and Shielded Room (8m×4m×3m) of Shenzhen Huatongwei International Inspection Co., Ltd. has been registered in accordance with the Regulations for Voluntary Control Measures with Registration No.: G-292. Date of Registration: Dec. 24, 2010. Valid time is until Dec. 23, 2013.

Main Ports Conducted Interference Measurement of Shenzhen Huatongwei International Inspection Co., Ltd. has been registered in accordance with the Regulations for Voluntary Control Measures with Registration No.: C-2726. Date of Registration: Dec. 20, 2012. Valid time is until Dec. 19, 2015.

Telecommunication Ports Conducted Interference Measurement of Shenzhen Huatongwei International Inspection Co., Ltd. has been registered in accordance with the Regulations for Voluntary Control Measures with Registration No.: T-1837. Date of Registration: May 07, 2010. Valid time is until May 06, 2013.

DNV

Shenzhen Huatongwei International Inspection Co., Ltd. has been found to comply with the requirements of DNV towards subcontractor of EMC and safety testing services in conjunction with the EMC and Low voltage Directives and in the voluntary field. The acceptance is based on a formal quality Audit and follow-ups according to relevant parts of ISO/IEC Guide 17025 (2005), in accordance with the requirements of the DNV Laboratory Quality Manual towards subcontractors. Valid time is until Aug. 24, 2013.

3.3. Environmental conditions

During the measurement the environmental conditions were within the listed ranges:

Temperature:	15-35 ° C
Humidity:	30-60 %
Atmospheric pressure:	950-1050mbar

3.4. Configuration of Tested System

Fig. 2-1 Configuration of Tested System

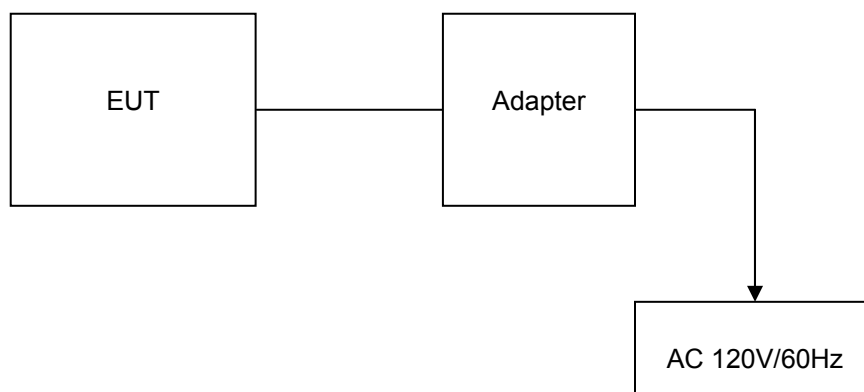

Table 2-1 Equipment Used in Tested System

Adapter: P/N: PS7501
 Model: NU90-9120700-12
 Input:100-240V~, 1.5A.50/60Hz
 Output: +12V DC 7A
 Power Cable: 180cm
 ◇ Shielded ◆ Unshielded

3.5. Discription of Tested Modes

The EUT has been tested under normal operating condition. Five channels (the high, the middle and the low) are chosen for testing at each channel separation (12.5 KHz).

3.6. Statement of the measurement uncertainty

The data and results referenced in this document are true and accurate. The reader is cautioned that there may be errors within the calibration limits of the equipment and facilities. The measurement uncertainty was calculated for all measurements listed in this test report acc. to CISPR 16 - 4 „Specification for radio disturbance and immunity measuring apparatus and methods – Part 4: Uncertainty in EMC Measurements“ and is documented in the Shenzhen Huatongwei International Inspection Co., Ltd quality system acc. to DIN EN ISO/IEC 17025. Furthermore, component and process variability of devices similar to

that tested may result in additional deviation. The manufacturer has the sole responsibility of continued compliance of the device.

Hereafter the best measurement capability for Shenzhen Huatongwei laboratory is reported:

Test Items	Measurement Uncertainty	Notes
Frequency stability	25 Hz	(1)
Transmitter power conducted	0.57 dB	(1)
Transmitter power Radiated	2.20 dB	(1)
Conducted spurious emission 9KHz-12.75 GHz	1.60 dB	(1)
Conducted Emission 9KHz-30MHz	3.39 dB	(1)
Radiated Emission 30~1000MHz	4.65 dB	(1)
Radiated Emissio 1~18GHz	5.16 dB	(1)
Radiated Emissio 18-40GHz	5.54 dB	(1)
Occupied Bandwidth	-----	(1)
Emission Mask	-----	(1)
Modulation Characteristic	-----	(1)
Transmitter Frequency Behavior	-----	(1)

(1) This uncertainty represents an expanded uncertainty expressed at approximately the 95% confidence level using a coverage factor of k=1.96.

3.7. Test Description

FCC Rules	Description of Test	Test Result
§ 15.107	Conducted Emission	Complies
§ 15.109	Receiver Radiated Spurious Emssion	Complies
§ 15.109	Receiver Conducted Spurious Emssion	Complies
§ 90.205	Maximum Transmitter Power	Complies
§ 90.207	Modulation Characteristic	Complies
§ 90.209	Occupied Bandwidth	Complies
§ 90.210	Emission Mask	Complies
§ 90.213	Frequency Stability	Complies
§ 90.214	Transmitter Frequency Behavior	Complies
§ 90.210	Transmitter Radiated Spurious Emssion	Complies
§ 90.210	Spurious Emssion On Antenna Port	Complies

3.8. Equipments Used during the Test

AC Power Conducted Emission				
Name of Equipment	Manufacturer	Model	Serial Number	Calibration Due
Artificial Mains	Rohde&Schwarz	ESH2-Z5	100028	10/27/2013
EMI Test Receiver	Rohde&Schwarz	ESCS 30	100038	10/27/2013
Pulse Limiter	Rohde&Schwarz	ESHSZ2	100044	10/27/2013
EMI Test Software	Rohde&Schwarz	ES-K1 V1.71	N/A	10/27/2013
RF COMMUNICATION TEST SET	HP	8920A	3813A10206	10/27/2013
Vertor Signal Genertor	Rohde&Schwarz	SMU200A	1141.2205.02	10/27/2013

Modulation Characteristic				
Name of Equipment	Manufacturer	Model	Serial Number	Calibration Due
RF COMMUNICATION TEST SET	HP	8920A	3813A10206	10/27/2013

Transmitter Radiated Spurious Emission & Occupied Bandwidth & Emission Mask & Receiver Radiated Spurious Emission				
Name of Equipment	Manufacturer	Model	Serial Number	Calibration Due
Ultra-Broadband Antenna	Rohde&Schwarz	HL562	100015	10/27/2013
EMI Test Receiver	Rohde&Schwarz	ESI 26	100009	10/27/2013
RF Test Panel	Rohde&Schwarz	TS / RSP	335015/ 0017	N/A
HORN ANTENNA	Rohde&Schwarz	HF906	100039	10/27/2013
Turntable	ETS	2088	2149	N/A
Antenna Mast	ETS	2075	2346	N/A
EMI Test Software	Rohde&Schwarz	ES-K1 V1.71	N/A	10/27/2013
RF COMMUNICATION TEST SET	HP	8920A	3813A10206	10/27/2013
Ultra-Broadband Antenna	ShwarzBeck	VULB9163	538	10/27/2013
Ultra-Broadband Antenna	ShwarzBeck	VULB9163	539	10/27/2013
HORN ANTENNA	ShwarzBeck	9120D	1012	10/27/2013
HORN ANTENNA	ShwarzBeck	9120D	1011	10/27/2013
TURNTABLE	MATURO	TT2.0	----	10/27/2013
ANTENNA MAST	MATURO	TAM-4.0-P	----	10/27/2013

Frequency Stability				
Name of Equipment	Manufacturer	Model	Serial Number	Calibration Due
Communication Test Set	HP	HP8920B	US35010135	10/27/2013
Signal Generator	Rohde&Schwarz	SMT03	100059	10/27/2013
Climate Chamber	ESPEC	EL-10KA	05107008	10/27/2013

Maximum Transmitter Power & Spurious Emission On Antenna Port				
Name of Equipment	Manufacturer	Model	Serial Number	Calibration Due
Receiver	Rohde&Schwarz	ESI 26	100009	10/27/2013
Attenuator	R&S	ESH3-22	100449	10/27/2013
RF COMMUNICATION TEST SET	HP	8920A	3813A10206	10/27/2013
High-Pass Filter	Anritsu	MP526B	6220875256	10/27/2013
High-Pass Filter	Anritsu	MP526D	6220878392	10/27/2013
Spectrum Analyzer	Aglient	E4407B	MY44210775	10/27/2013
Spectrum Analyzer	Rohde&Schwarz	FSP40	1164.4391.40	10/27/2013

Transient Frequency Behavior				
Name of Equipment	Manufacturer	Model	Serial Number	Calibration Due
Signal Generator	Rohde&Schwarz	SMT03	100059	10/27/2013
Storage Oscilloscope	Tektronix	TDS3054B	B033027	10/27/2013
RF COMMUNICATION TEST SET	HP	8920A	3813A10206	10/27/2013

The calibration interval was one year.

4. TEST CONDITIONS AND RESULTS

4.1. Conducted Emissions Test

TEST APPLICABLE

The EUT was tested according to ANSI C63.4 - 2009. The frequency spectrum from 0.15 MHz to 30 MHz was investigated. The LISN used was 50 ohm / 50 u Henry as specified by section 5.1 of ANSI C63.4 - 2009. Cables and peripherals were moved to find the maximum emission levels for each frequency.

TEST CONFIGURATION

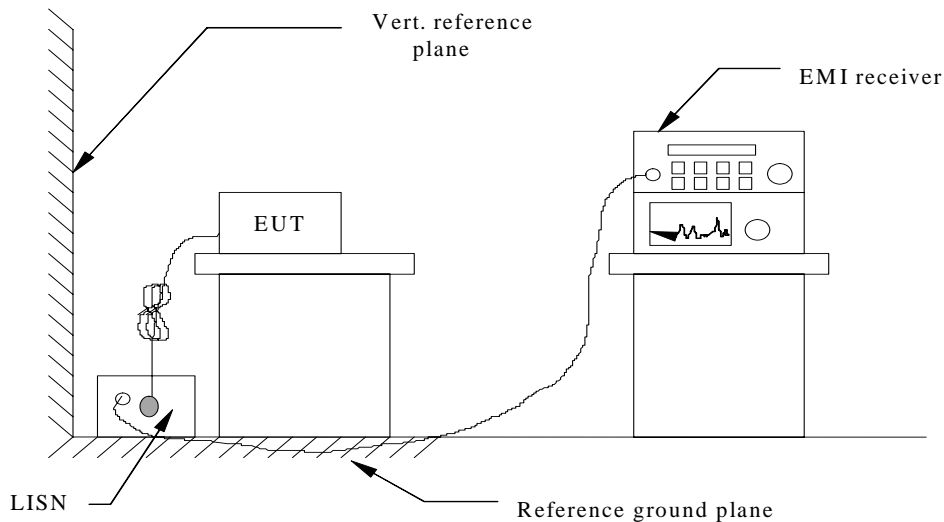

TEST PROCEDURE

- 1 The equipment was set up as per the test configuration to simulate typical actual usage per the user's manual. The EUT is a tabletop system; a wooden table with a height of 0.8 meters is used and is placed on the ground plane as per ANSI C63.4-2009.
- 2 Support equipment, if needed, was placed as per ANSI C63.4-2009.
- 3 All I/O cables were positioned to simulate typical actual usage as per ANSI C63.4-2009.
- 4 If a EUT received DC power from the adapter, the adapter received AC120V/60Hz power through a Line Impedance Stabilization Network (LISN) which supplied power source and was grounded to the ground plane.
- 5 All support equipments received AC power from a second LISN, if any.
- 6 The EUT test program was started. Emissions were measured on each current carrying line of the EUT using a spectrum Analyzer / Receiver connected to the LISN powering the EUT. The LISN has two monitoring points: Line 1 (Hot Side) and Line 2 (Neutral Side). Two scans were taken: one with Line 1 connected to Analyzer / Receiver and Line 2 connected to a 50 ohm load; the second scan had Line 1 connected to a 50 ohm load and Line 2 connected to the Analyzer / Receiver.
- 7 Analyzer / Receiver scanned from 150 KHz to 30MHz for emissions in each of the test modes.
- 8 During the above scans, the emissions were maximized by cable manipulation.

Conducted Power Line Emission Limit

For unintentional device, according to § 15.107(a) Line Conducted Emission Limits is as following :

Frequency (MHz)	Maximum RF Line Voltage (dBµV)			
	CLASS A		CLASS B	
	Q.P.	Ave.	Q.P.	Ave.
0.15 - 0.50	79	66	66-56*	56-46*
0.50 - 5.00	73	60	56	46
5.00 - 30.0	73	60	60	50

* Decreasing linearly with the logarithm of the frequency

For intentional device, according to §15.207(a) Line Conducted Emission Limit is same as above table.

TEST RESULTS

For FM Modulation @ 12.5 KHz TX Mode

SCAN TABLE: "Voltage (9K-30M) FIN"

Short Description: 150K-30M Voltage

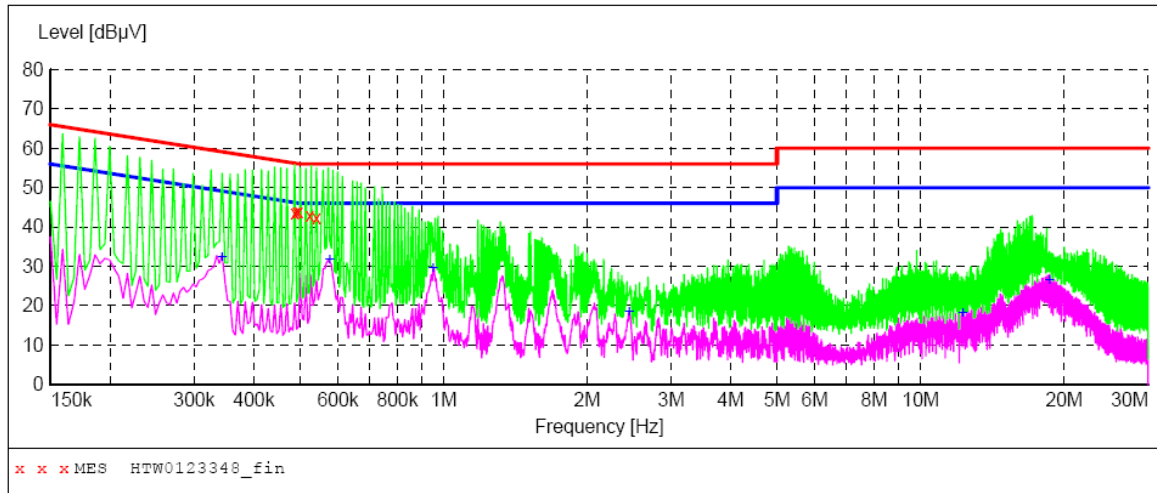

MEASUREMENT RESULT: "HTW0123348_fin"

1/23/2013 5:14PM

Frequency MHz	Level dBµV	Transd dB	Limit dBµV	Margin dB	Detector	Line	PE
0.487500	43.40	10.2	56	12.8	QP	N	GND
0.492000	43.90	10.2	56	12.2	QP	N	GND
0.496500	43.80	10.2	56	12.3	QP	N	GND
0.523500	42.80	10.2	56	13.2	QP	N	GND
0.541500	42.20	10.2	56	13.8	QP	N	GND

MEASUREMENT RESULT: "HTW0123348_fin2"

1/23/2013 5:14PM

Frequency MHz	Level dBµV	Transd dB	Limit dBµV	Margin dB	Detector	Line	PE
0.343500	32.30	10.2	49	16.8	AV	N	GND
0.577500	31.70	10.2	46	14.3	AV	N	GND
0.951000	29.50	10.3	46	16.5	AV	N	GND
2.449500	18.50	10.4	46	27.5	AV	N	GND
12.286500	18.10	10.6	50	31.9	AV	N	GND
18.645000	26.70	10.9	50	23.3	AV	N	GND

SCAN TABLE: "Voltage (9K-30M)FIN"

Short Description: 150K-30M Voltage

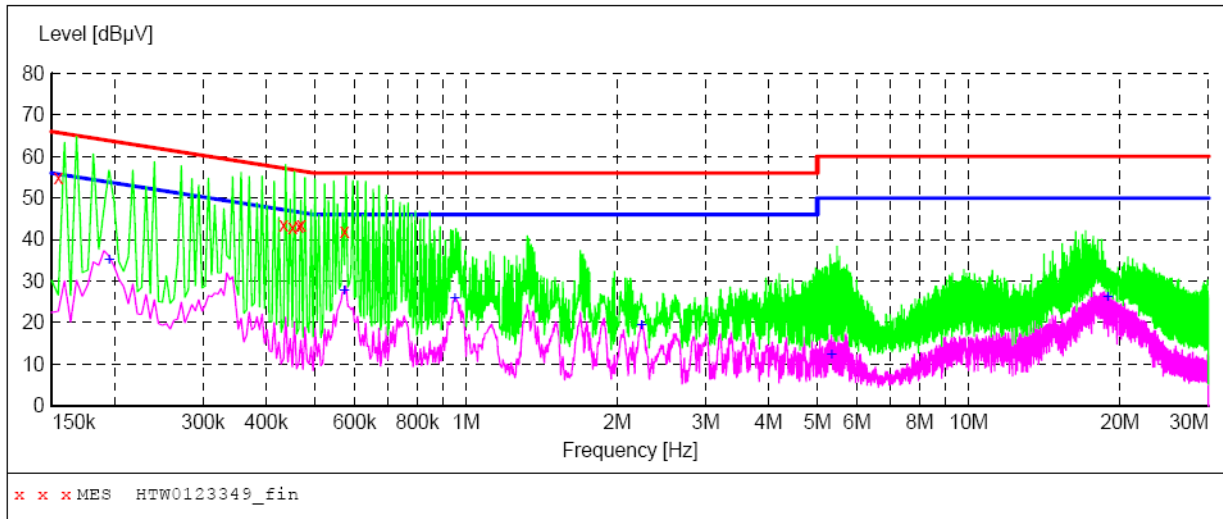

MEASUREMENT RESULT: "HTW0123349_fin"

1/23/2013 5:17PM

Frequency MHz	Level dBµV	Transd dB	Limit dBµV	Margin dB	Detector	Line	PE
0.154500	54.90	10.2	66	10.9	QP	L1	GND
0.433500	43.60	10.2	57	13.6	QP	L1	GND
0.451500	42.80	10.2	57	14.0	QP	L1	GND
0.465000	43.30	10.2	57	13.3	QP	L1	GND
0.469500	43.40	10.2	57	13.1	QP	L1	GND
0.573000	42.10	10.2	56	13.9	QP	L1	GND

MEASUREMENT RESULT: "HTW0123349_fin2"

1/23/2013 5:17PM

Frequency MHz	Level dBµV	Transd dB	Limit dBµV	Margin dB	Detector	Line	PE
0.195000	35.20	10.2	54	18.6	AV	L1	GND
0.573000	27.90	10.2	46	18.1	AV	L1	GND
0.951000	26.00	10.3	46	20.0	AV	L1	GND
2.238000	19.30	10.4	46	26.7	AV	L1	GND
5.343000	12.30	10.4	50	37.7	AV	L1	GND
18.928500	26.40	10.9	50	23.6	AV	L1	GND

For 4FSK Modulation @ 12.5 KHz TX Mode

SCAN TABLE: "Voltage (9K-30M) FIN"

Short Description: 150K-30M Voltage

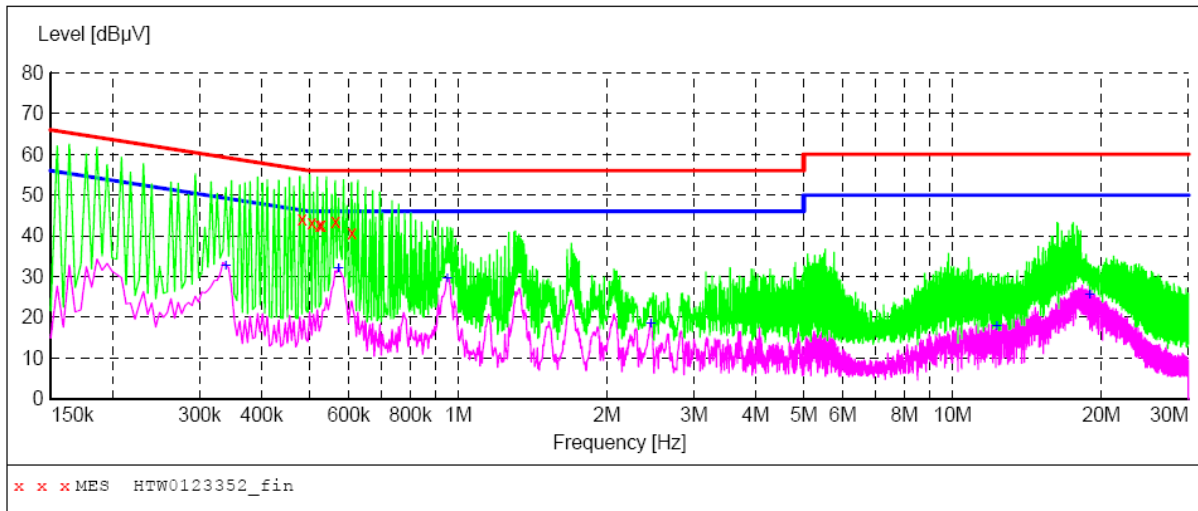

MEASUREMENT RESULT: "HTW0123352_fin"

1/23/2013 5:26PM

Frequency MHz	Level dBµV	Transd dB	Limit dBµV	Margin dB	Detector	Line	PE
0.483000	44.00	10.2	56	12.3	QP	N	GND
0.505500	43.20	10.2	56	12.8	QP	N	GND
0.523500	42.70	10.2	56	13.3	QP	N	GND
0.528000	42.60	10.2	56	13.4	QP	N	GND
0.564000	43.40	10.2	56	12.6	QP	N	GND
0.609000	40.60	10.2	56	15.4	QP	N	GND

MEASUREMENT RESULT: "HTW0123352_fin2"

1/23/2013 5:26PM

Frequency MHz	Level dBµV	Transd dB	Limit dBµV	Margin dB	Detector	Line	PE
0.339000	32.90	10.2	49	16.3	AV	N	GND
0.573000	32.20	10.2	46	13.8	AV	N	GND
0.951000	29.70	10.3	46	16.3	AV	N	GND
2.454000	18.50	10.4	46	27.5	AV	N	GND
12.291000	17.80	10.6	50	32.2	AV	N	GND
18.937500	25.50	10.9	50	24.5	AV	N	GND

SCAN TABLE: "Voltage (9K-30M)FIN"
 Short Description: 150K-30M Voltage

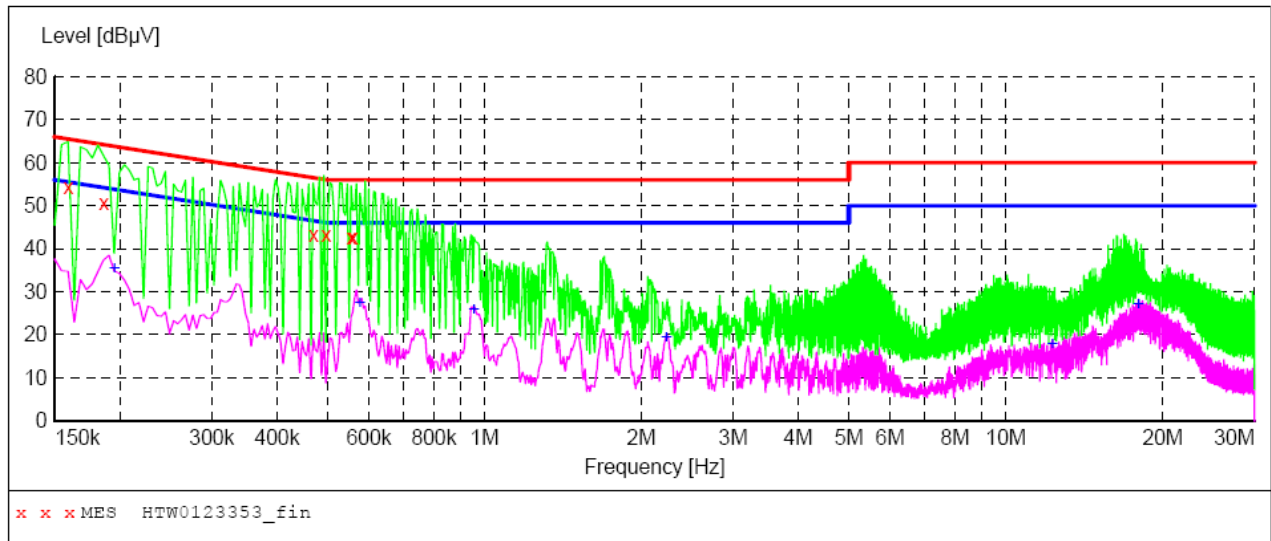

MEASUREMENT RESULT: "HTW0123353_fin"

1/23/2013 5:30PM

Frequency MHz	Level dBuV	Transd dB	Limit dBuV	Margin dB	Detector	Line	PE
0.159000	54.30	10.2	66	11.2	QP	L1	GND
0.186000	50.60	10.2	64	13.6	QP	L1	GND
0.469500	43.20	10.2	57	13.3	QP	L1	GND
0.496500	43.10	10.2	56	13.0	QP	L1	GND
0.555000	42.60	10.2	56	13.4	QP	L1	GND
0.559500	42.60	10.2	56	13.4	QP	L1	GND

MEASUREMENT RESULT: "HTW0123353_fin2"

1/23/2013 5:30PM

Frequency MHz	Level dBuV	Transd dB	Limit dBuV	Margin dB	Detector	Line	PE
0.195000	35.40	10.2	54	18.4	AV	L1	GND
0.577500	27.40	10.2	46	18.6	AV	L1	GND
0.955500	25.80	10.3	46	20.2	AV	L1	GND
2.233500	19.30	10.4	46	26.7	AV	L1	GND
12.291000	17.90	10.6	50	32.1	AV	L1	GND
17.979000	27.20	10.8	50	22.8	AV	L1	GND

4.2. Occupied Bandwidth and Emission Mask Test

TEST APPLICABLE

- (a). Occupied Bandwidth: The EUT was connected to the audio signal generator and the spectrum analyzer via the main RF connector, and through an appropriate attenuator. The EUT was controlled to transmit its maximum power. Then the bandwidth of 99% power can be measured by the spectrum analyzer.
- (b). Emission Mask B: For transmitters that are equipped with an audio low-pass filter pursuant to §90.211(a), the power of any emission must be below the unmodulated carrier power (P) as follows:
- (1) On any frequency removed from the assigned frequency by more than 50 percent, but not more than 100 percent of the authorized bandwidth: At least 25 dB.
 - (2) On any frequency removed from the assigned frequency by more than 100 percent, but not more than 250 percent of the authorized bandwidth: At least 35 dB.
 - (3) On any frequency removed from the assigned frequency by more than 250 percent of the authorized bandwidth: At least $43 + 10 \log (P)$ dB.
- (c). Emission Mask D, 12.5 kHz channel bandwidth equipment: For transmitters designed to operate with a 12.5 kHz channel bandwidth, any emission must be attenuated below the power (P) of the highest emission contained within the authorized bandwidth as follows:
- (1) On any frequency from the center of the authorized bandwidth f_0 to 5.625 kHz removed from f_0 : Zero dB.
 - (2) On any frequency removed from the center of the authorized bandwidth by a displacement frequency (f_d in kHz) of more than 5.625 kHz but no more than 12.5 kHz: At least $7.27(f_d - 2.88 \text{ kHz})$ dB.
 - (3) On any frequency removed from the center of the authorized bandwidth by a displacement frequency (f_d in kHz) of more than 12.5 kHz: At least $50 + 10 \log (P)$ dB or 70 dB, whichever is the lesser attenuation.

TEST CONFIGURATION

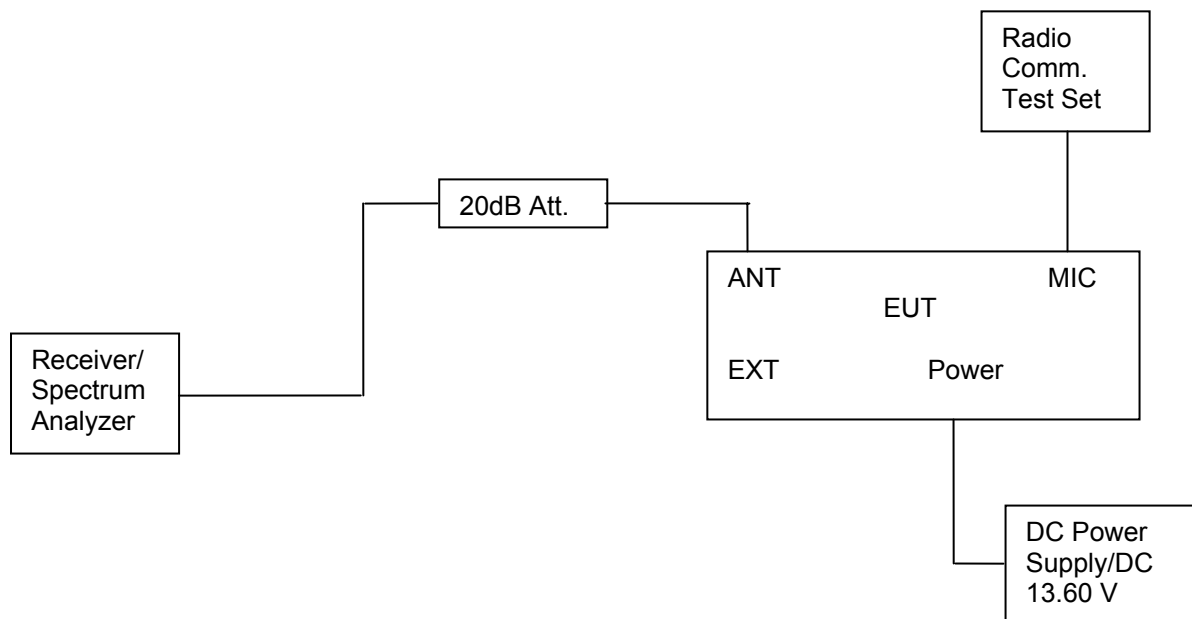

TEST PROCEDURE

- 1 The EUT was placed on a turn table which is 0.8m above ground plane.
- 2 The EUT was modulated by 2.5 KHz Sine wave audio signal; the level of the audio signal employed is 16 dB greater than that necessary to produce 50% of rated system deviation. Rated system deviation is 2.5 kHz (12.5 kHz channel spacing) and 5 kHz (25 kHz channel spacing).
- 3 Set EUT as normal operation.
- 4 Set SPA Center Frequency = fundamental frequency, RBW=300Hz, VBW= 3 KHz, span =50 KHz.
- 5 Set SPA Max hold. Mark peak, Set 99% Occupied Bandwidth and 26dB Occupied Bandwidth.
- 6 Set SPA Center Frequency=fundamental frequency, set =100Hz, VBW=1 KHz, span=50 KHz for 12.5 channel spacing.

Modulation Type	Channel Separation	Freq.(MHz)	99% Bandwidth (KHz)	26dB Bandwidth (KHz)	FCC Limit (KHz)	Results
FM	12.5 KHz	418.0000	9.80	10.60	11.25	Compliance

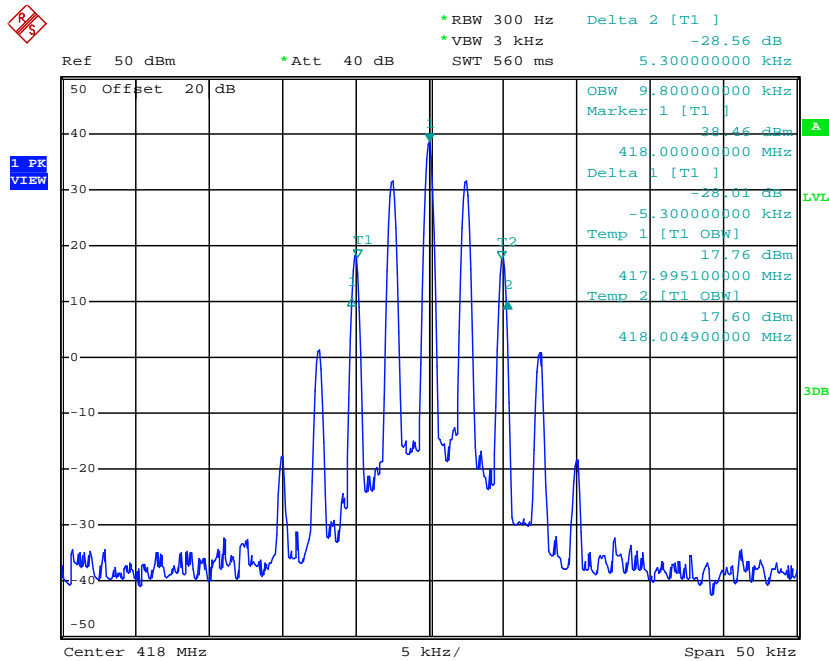

Date: 21.JAN.2013 15:22:59

Modulation Type	Channel Separation	Freq.(MHz)	99% Bandwidth (KHz)	26dB Bandwidth (KHz)	FCC Limit (KHz)	Results
FM	12.5 KHz	435.5000	9.80	10.60	11.25	Compliance

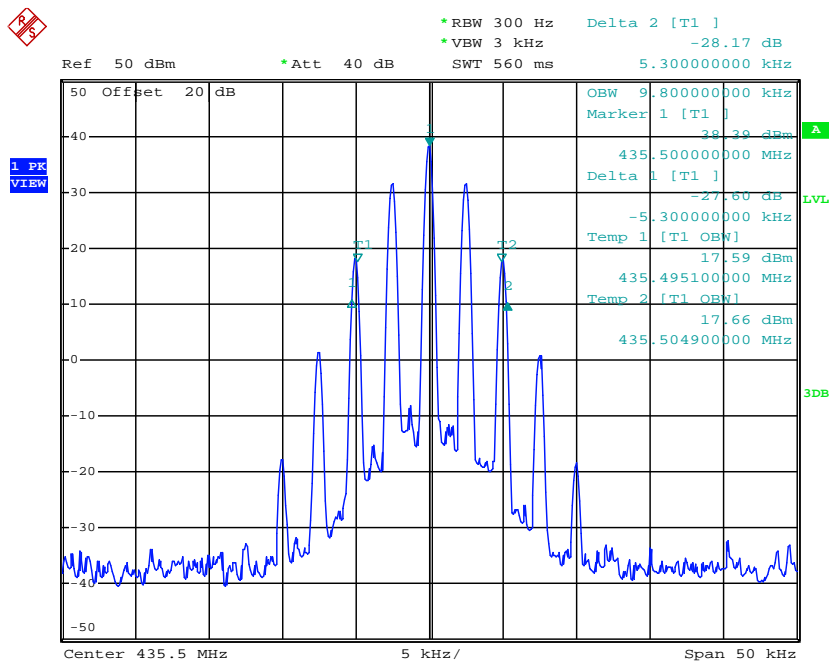

Date: 21.JAN.2013 15:23:44

Modulation Type	Channel Separation	Freq.(MHz)	99% Bandwidth (KHz)	26dB Bandwidth (KHz)	FCC Limit (KHz)	Results
FM	12.5 KHz	453.0000	9.80	10.60	11.25	Compliance

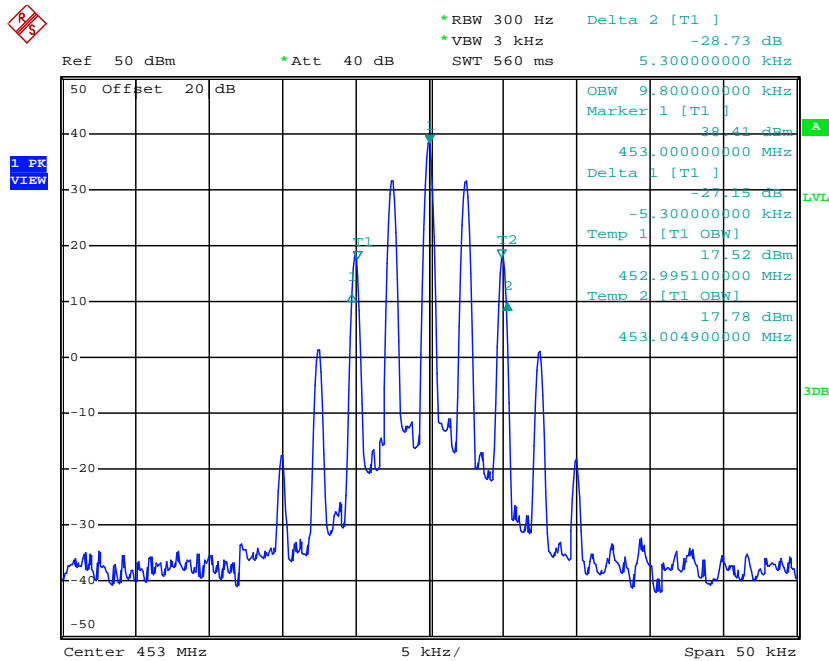

Date: 21.JAN.2013 15:28:58

Modulation Type	Channel Separation	Freq.(MHz)	99% Bandwidth (KHz)	26dB Bandwidth (KHz)	FCC Limit (KHz)	Results
FM	12.5 KHz	469.5000	9.80	10.60	11.25	Compliance

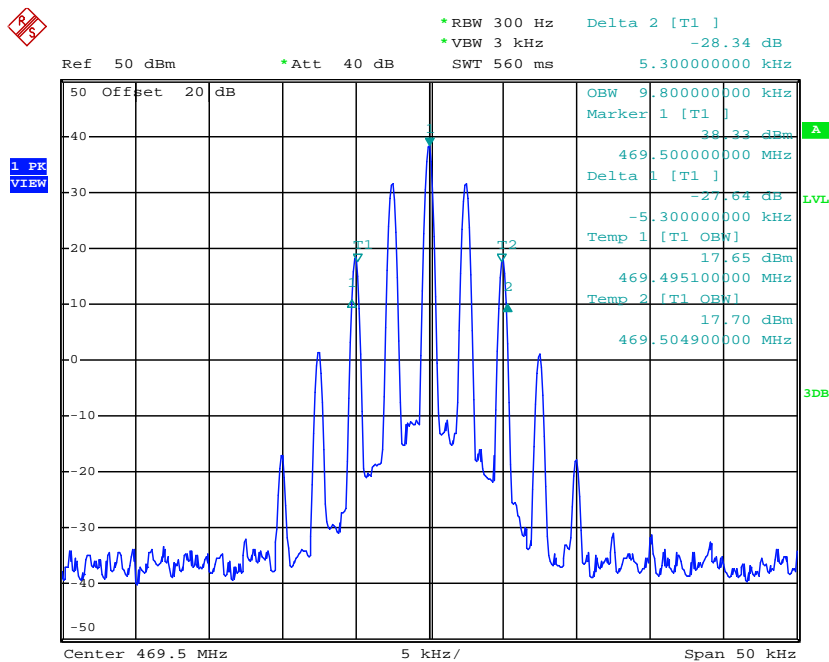

Date: 21.JAN.2013 15:29:38

Modulation Type	Channel Separation	Freq.(MHz)	99% Bandwidth (KHz)	26dB Bandwidth (KHz)	FCC Limit (KHz)	Results
4FSK	12.5 KHz	406.5000	7.90	10.30	11.25	Compliance

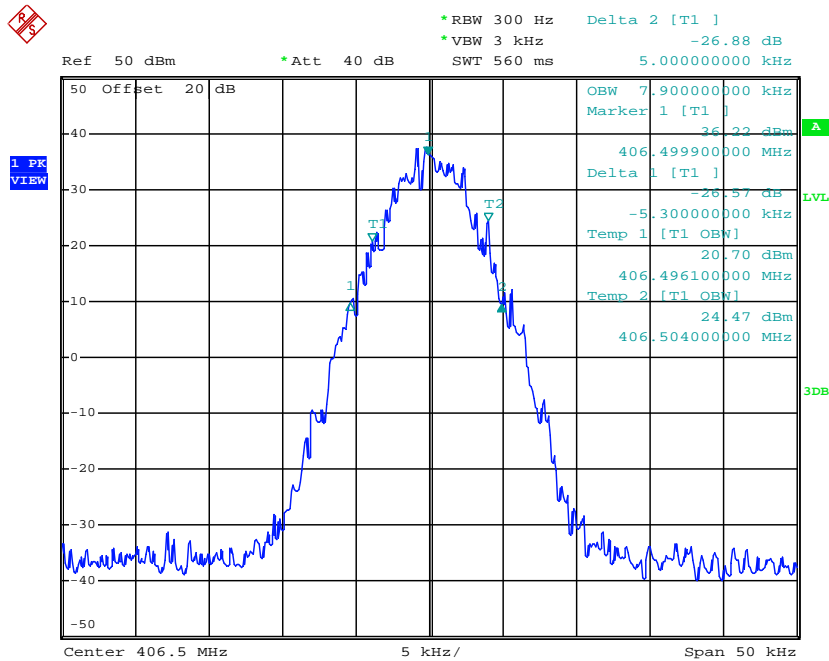

Date: 23.JAN.2013 15:25:40

Modulation Type	Channel Separation	Freq.(MHz)	99% Bandwidth (KHz)	26dB Bandwidth (KHz)	FCC Limit (KHz)	Results
4FSK	12.5 KHz	418.0000	8.00	9.80	11.25	Compliance

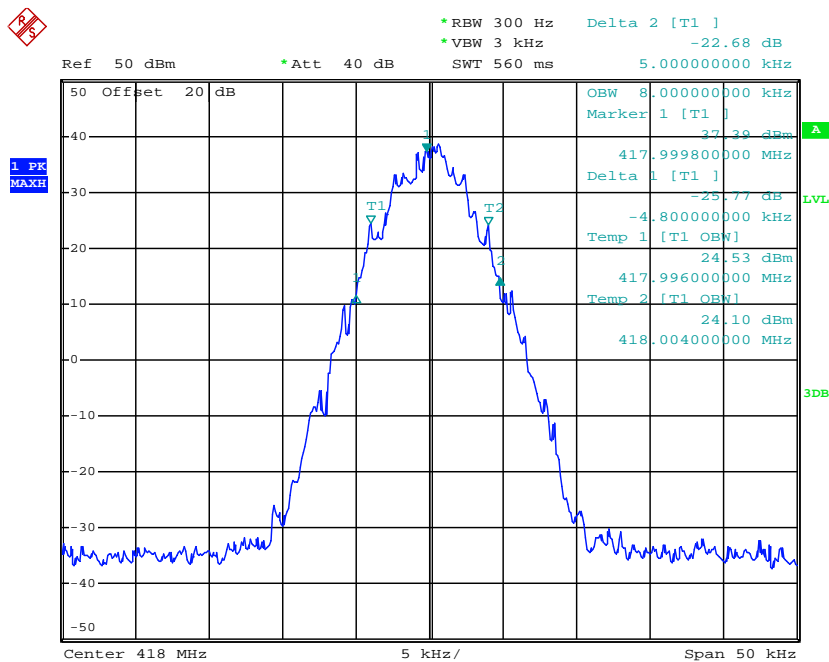

Date: 23.JAN.2013 15:26:24

Modulation Type	Channel Separation	Freq.(MHz)	99% Bandwidth (KHz)	26dB Bandwidth (KHz)	FCC Limit (KHz)	Results
4FSK	12.5 KHz	435.5000	7.70	9.80	11.25	Compliance

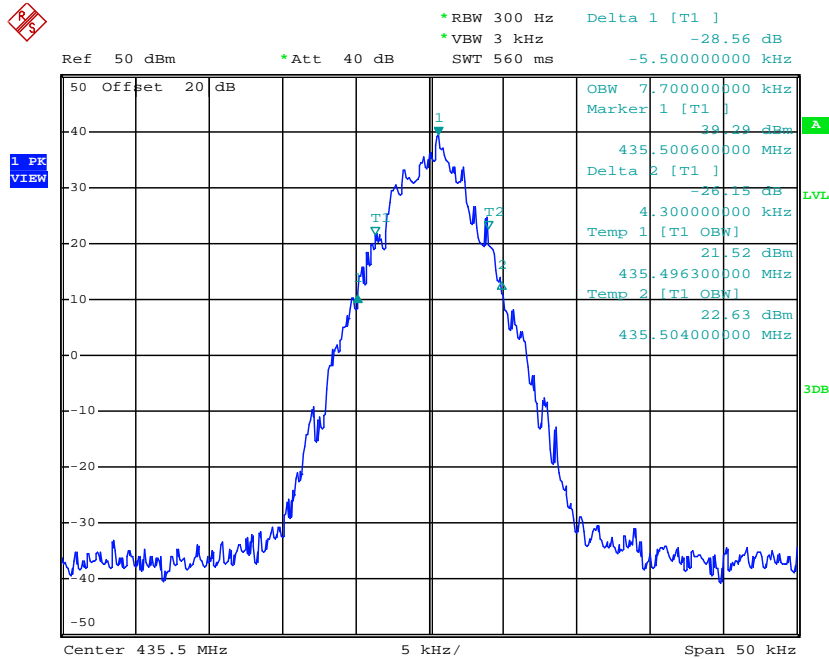

Date: 23.JAN.2013 15:27:28

Modulation Type	Channel Separation	Freq.(MHz)	99% Bandwidth (KHz)	26dB Bandwidth (KHz)	FCC Limit (KHz)	Results
4FSK	12.5 KHz	453.0000	8.20	9.90	11.25	Compliance

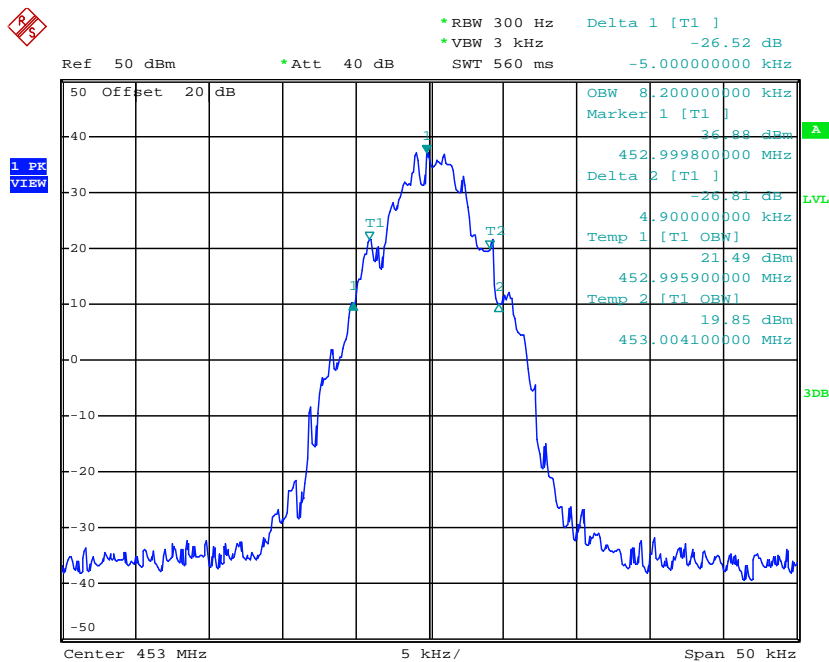

Date: 23.JAN.2013 15:29:27

Modulation Type	Channel Separation	Freq.(MHz)	99% Bandwidth (KHz)	26dB Bandwidth (KHz)	FCC Limit (KHz)	Results
4FSK	12.5 KHz	469.5000	7.50	9.80	11.25	Compliance

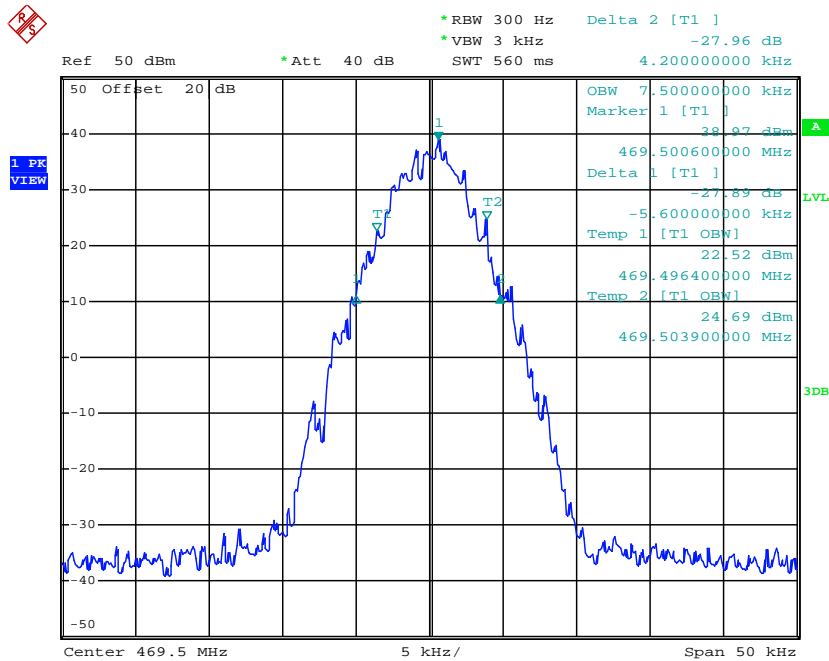

Date: 23.JAN.2013 15:30:19

4.2.2 Emission Mask

Modulation Type	Channel Separation	Test Channel	Test Frequency	FCC Applicable Mask	RBW
FM	12.5KHz	Low	406.5000 MHz	D	100 Hz
		Low	418.0000 MHz	D	100 Hz
		Middle	435.5000 MHz	D	100 Hz
		High	453.0000 MHz	D	100 Hz
		High	469.5000 MHz	D	100 Hz
4FSK	12.5KHz	Low	406.5000 MHz	D	100 Hz
		Low	418.0000 MHz	D	100 Hz
		Middle	435.5000 MHz	D	100 Hz
		High	453.0000 MHz	D	100 Hz
		High	469.5000 MHz	D	100 Hz
Test Results		Compliance			

Plots of Emission Mask Measurement

Referred as the attached plot hereinafter
 Note: The Blue curve represents unmodulated signal.
 The Black curve represents modulated signal.

Modulation Type	Channel Separation	Freq.(MHz)	FCC Applicable Mask	RBW	Audio Freq. (KHz)	Results
FM	12.5 KHz	406.5000	D	100	2.5	Compliance

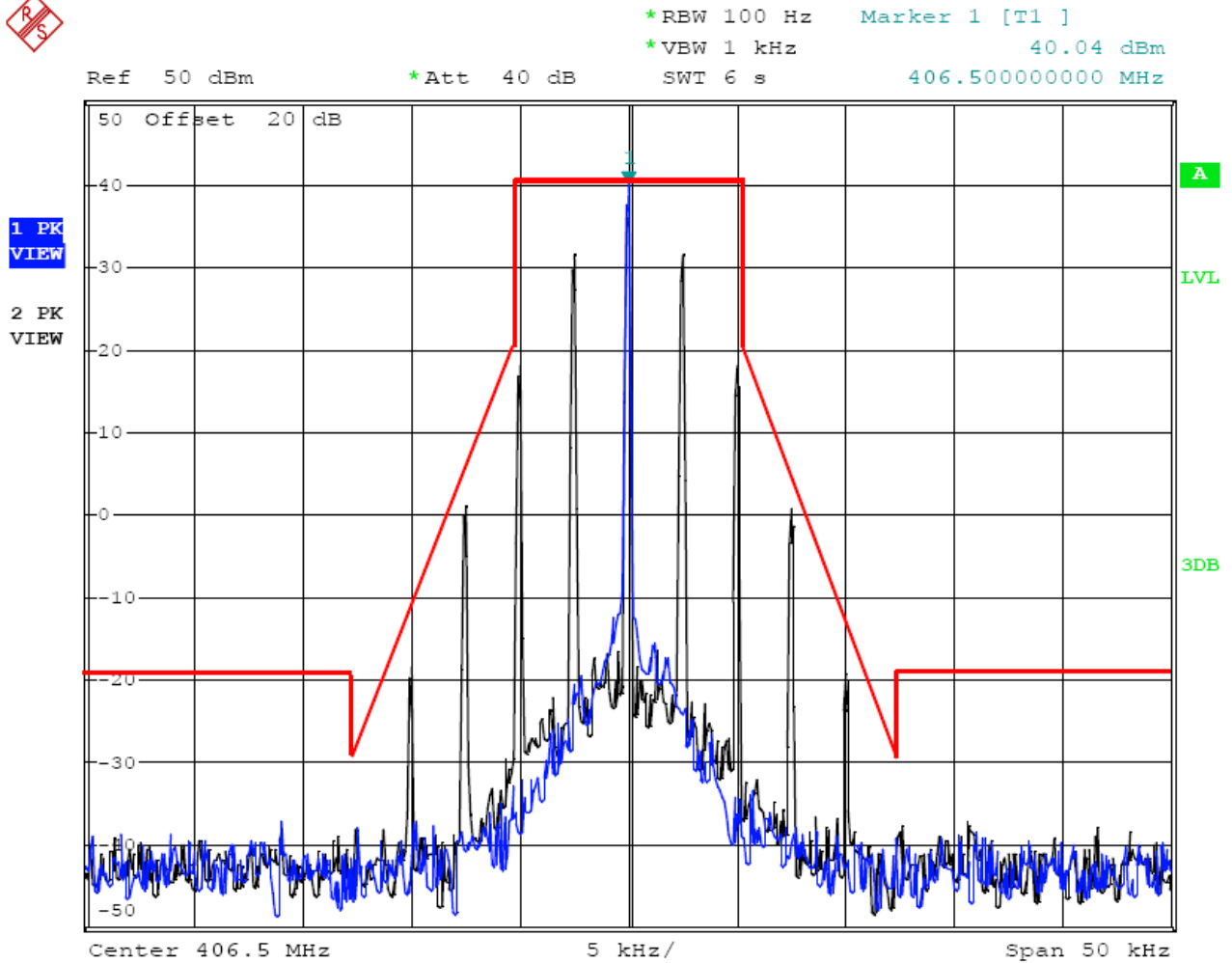

Date: 21.JAN.2013 15:40:47

12.5 kHz Channel Spacing, 406.5000 MHz, 2500 Hz Audio Modulation Only

Modulation Type	Channel Separation	Freq.(MHz)	FCC Applicable Mask	RBW	Audio Freq. (KHz)	Results
FM	12.5 KHz	418.0000	D	100	2.5	Compliance

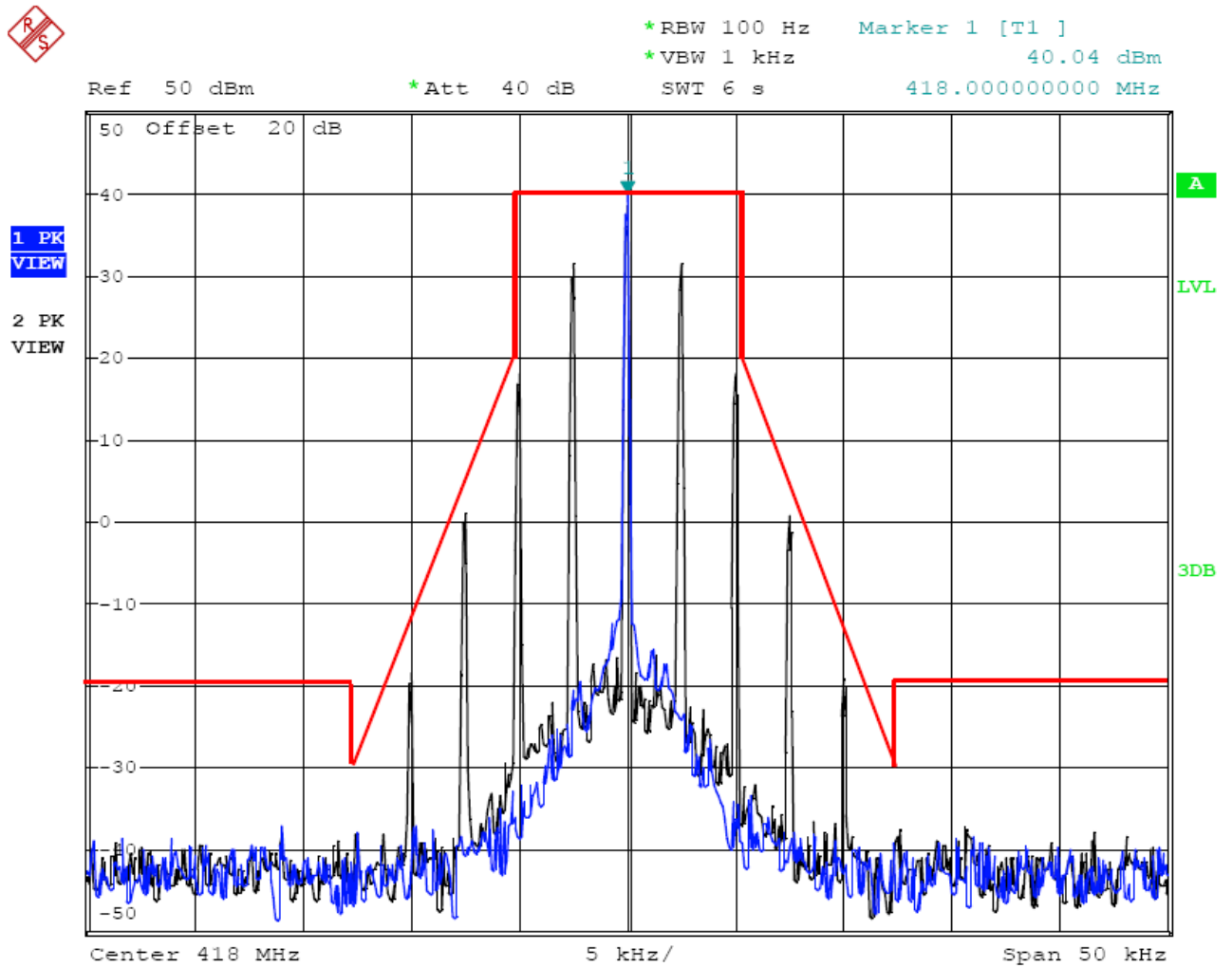

Date: 21.JAN.2013 15:35:04

12.5 kHz Channel Spacing, 418.0000 MHz, 2500 Hz Audio Modulation Only

Modulation Type	Channel Separation	Freq.(MHz)	FCC Applicable Mask	RBW	Audio Freq. (KHz)	Results
FM	12.5 KHz	435.5000	D	100Hz	2.5	Compliance



Ref 50 dBm *Att 40 dB SWT 6 s *RBW 100 Hz Marker 1 [T1] 39.98 dBm
435.50000000 MHz

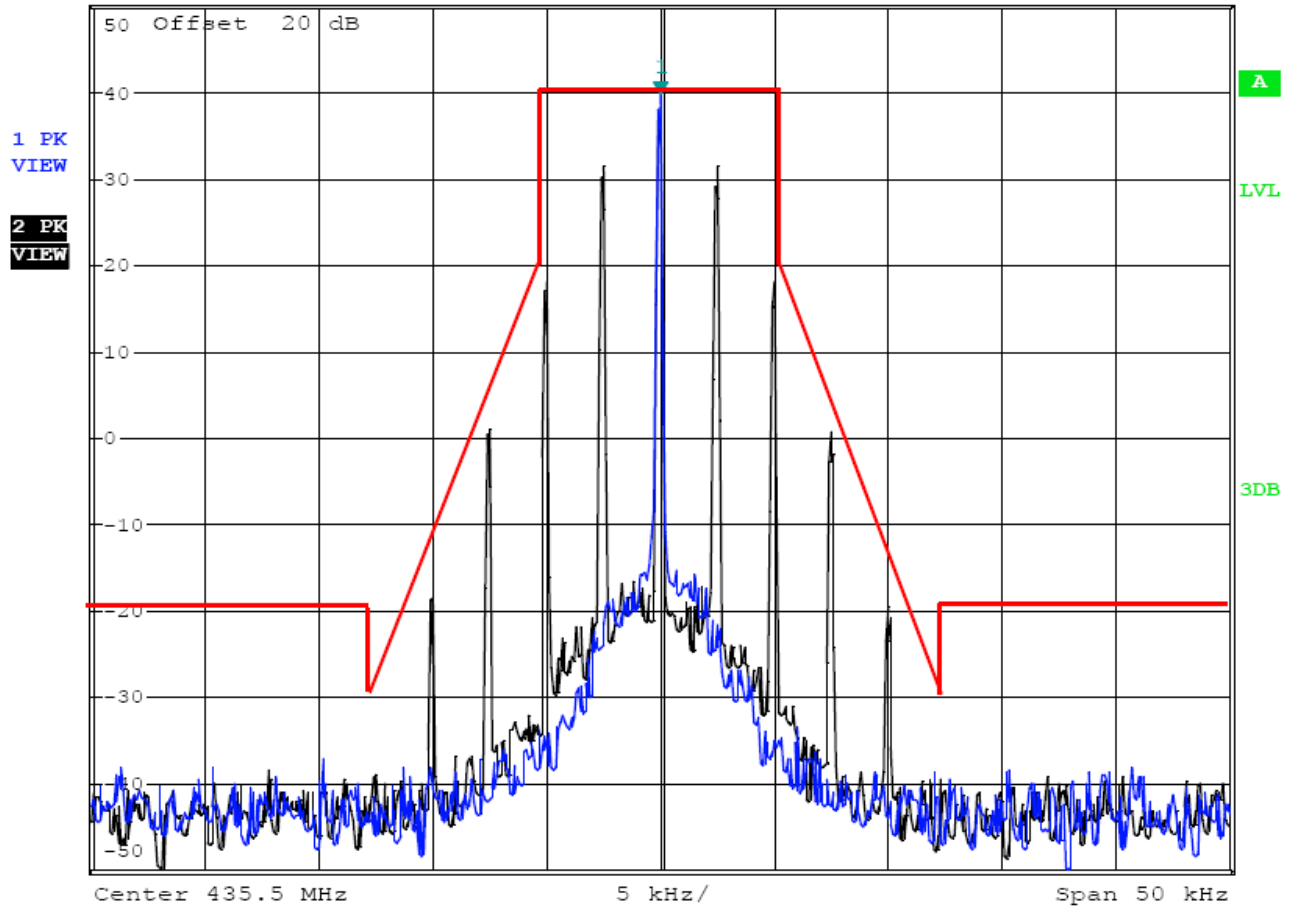

Date: 21.JAN.2013 15:33:52

12.5 kHz Channel Spacing, 435.5000 MHz, 2500 Hz Audio Modulation Only

Modulation Type	Channel Separation	Freq.(MHz)	FCC Applicable Mask	RBW	Audio Freq. (KHz)	Results
FM	12.5 KHz	453.0000	D	100Hz	2.5	Compliance

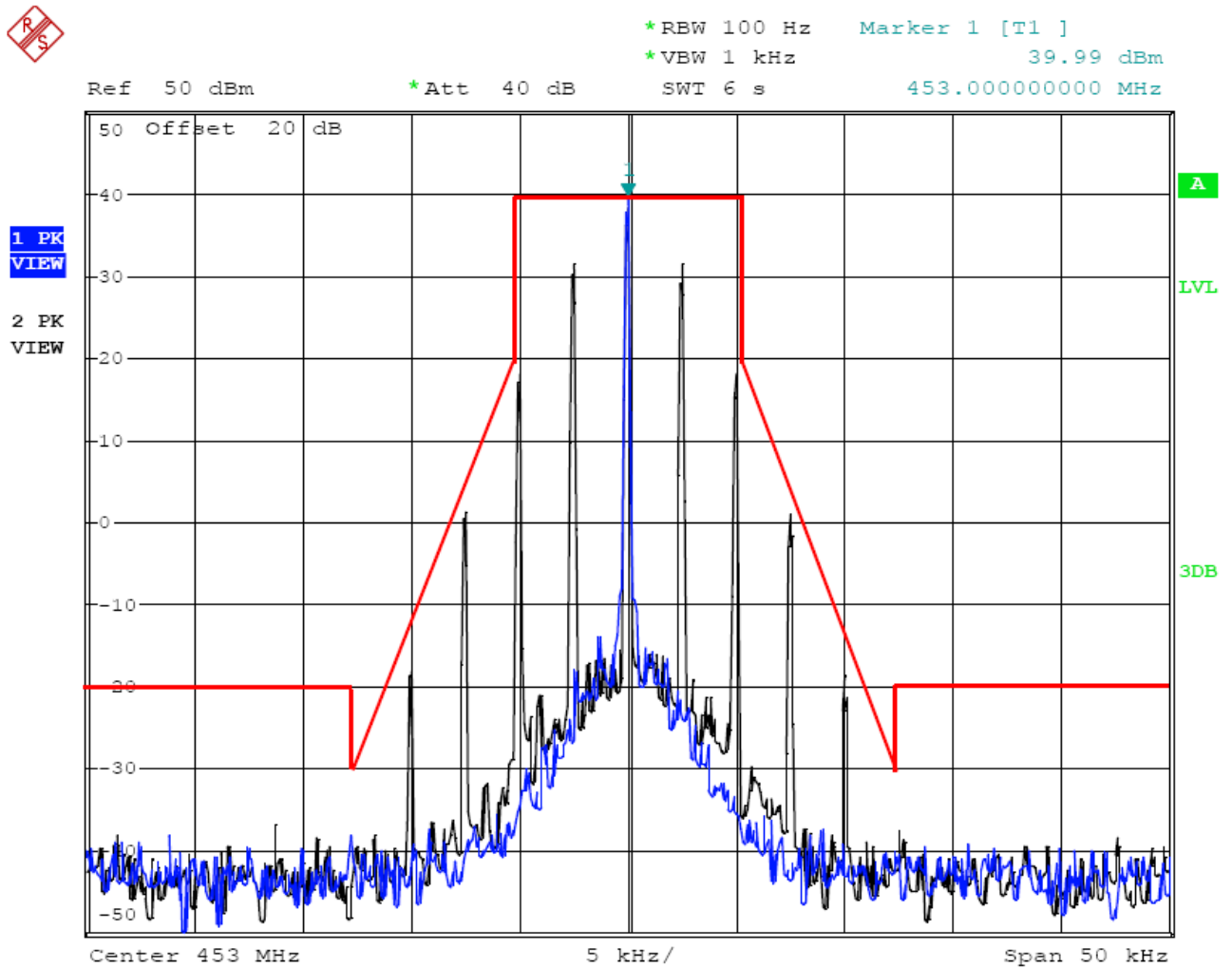

Date: 21.JAN.2013 15:32:20

12.5 kHz Channel Spacing, 453.0000 MHz, 2500 Hz Audio Modulation Only

Modulation Type	Channel Separation	Freq.(MHz)	IC Applicable Mask	RBW	Audio Freq. (KHz)	Results
4FSK	12.5 KHz	406.5000	D	100Hz	/	Compliance

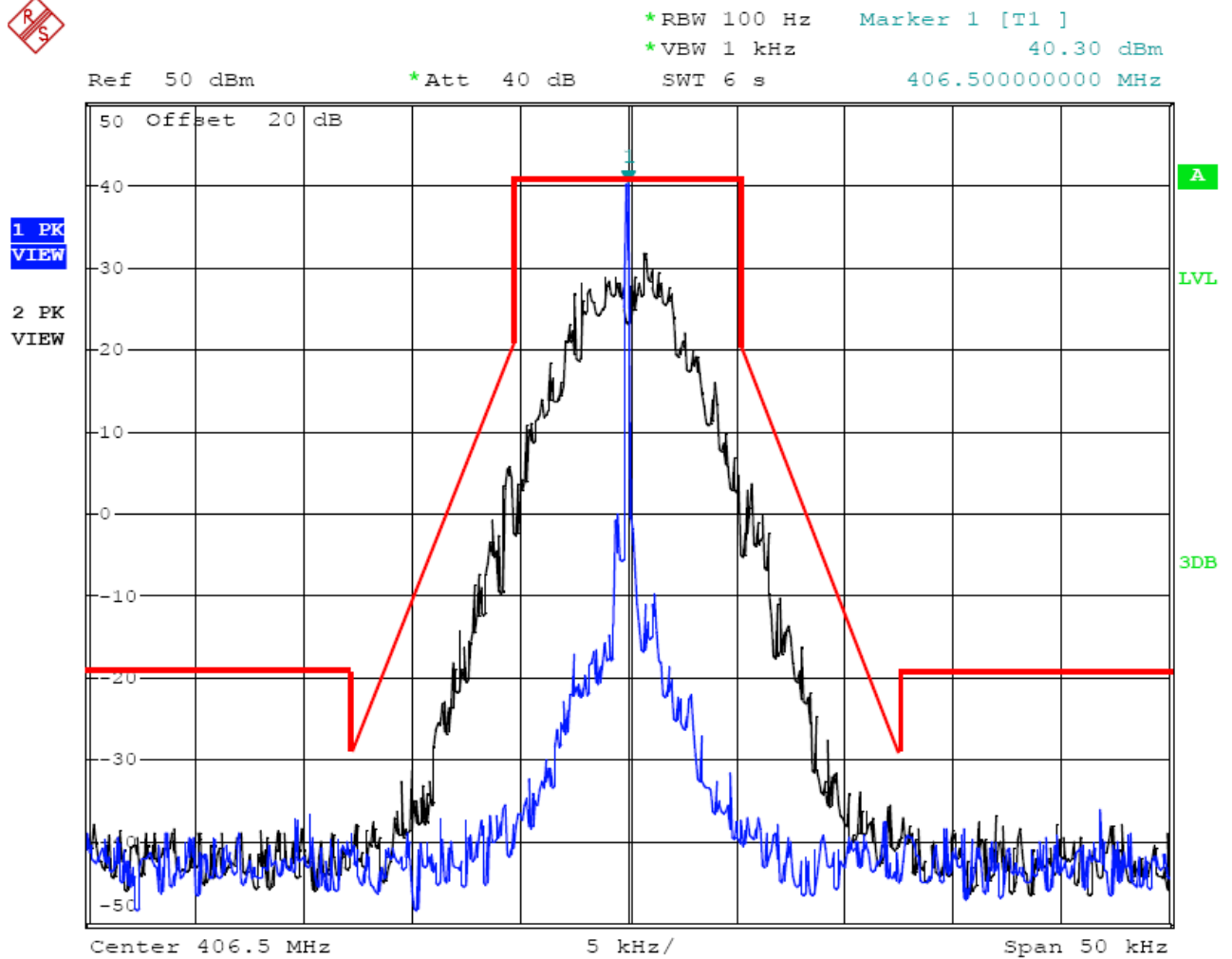

Date: 23.JAN.2013 15:46:42

12.5 kHz Channel Spacing, 406.5000 MHz, 2500 Hz 4FSK Modulation Only

Modulation Type	Channel Separation	Freq.(MHz)	IC Applicable Mask	RBW	Audio Freq. (KHz)	Results
4FSK	12.5 KHz	418.0000	D	100Hz	/	Compliance

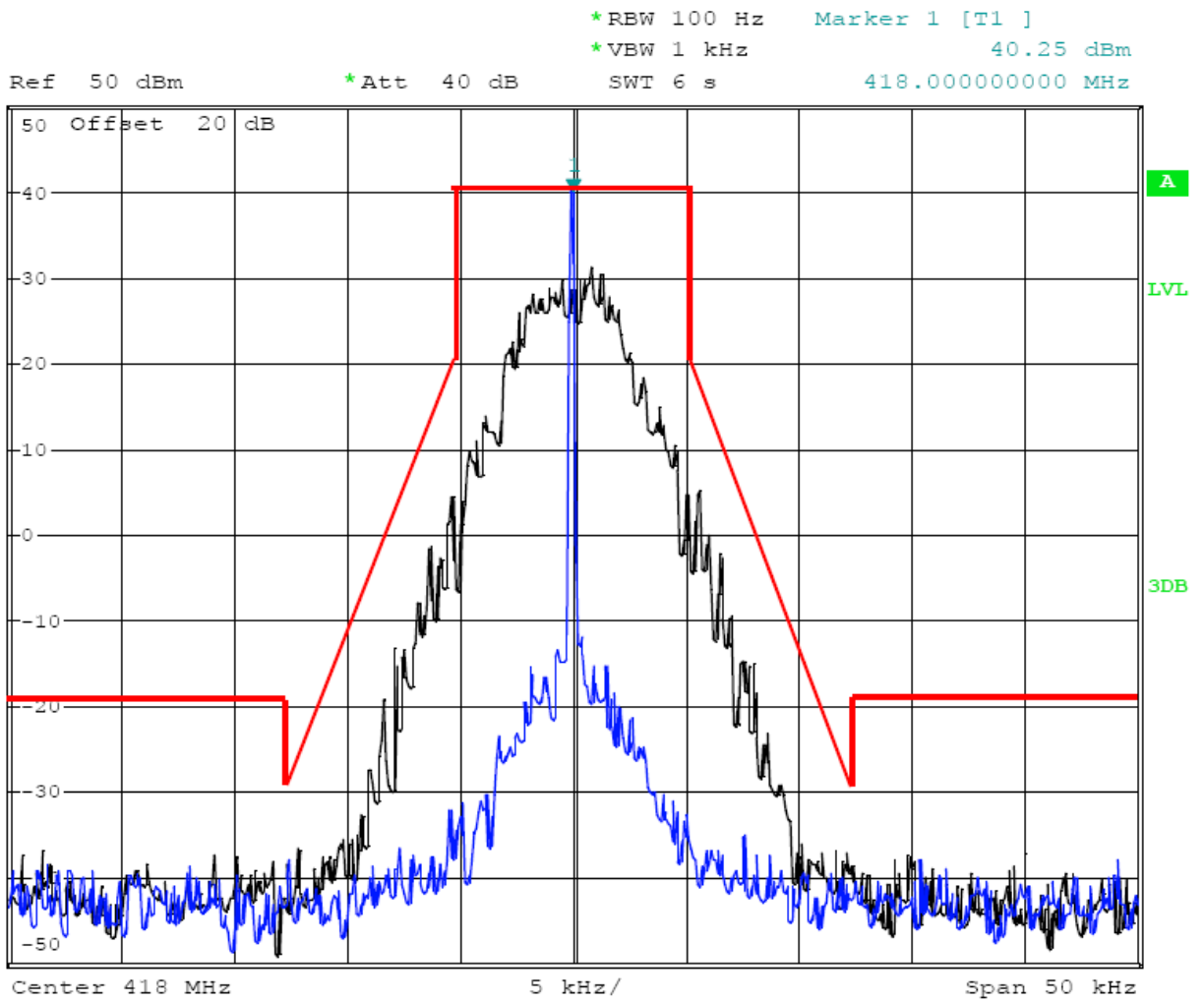

Date: 23.JAN.2013 15:41:55

12.5 kHz Channel Spacing, 418.0000 MHz, 2500 Hz 4FSK Modulation Only

Modulation Type	Channel Separation	Freq.(MHz)	IC Applicable Mask	RBW	Audio Freq. (KHz)	Results
4FSK	12.5 KHz	435.5000	D	100Hz	/	Complicance



Ref 50 dBm *Att 40 dB SWT 6 s *RBW 100 Hz Marker 1 [T1] 40.19 dBm
435.50000000 MHz

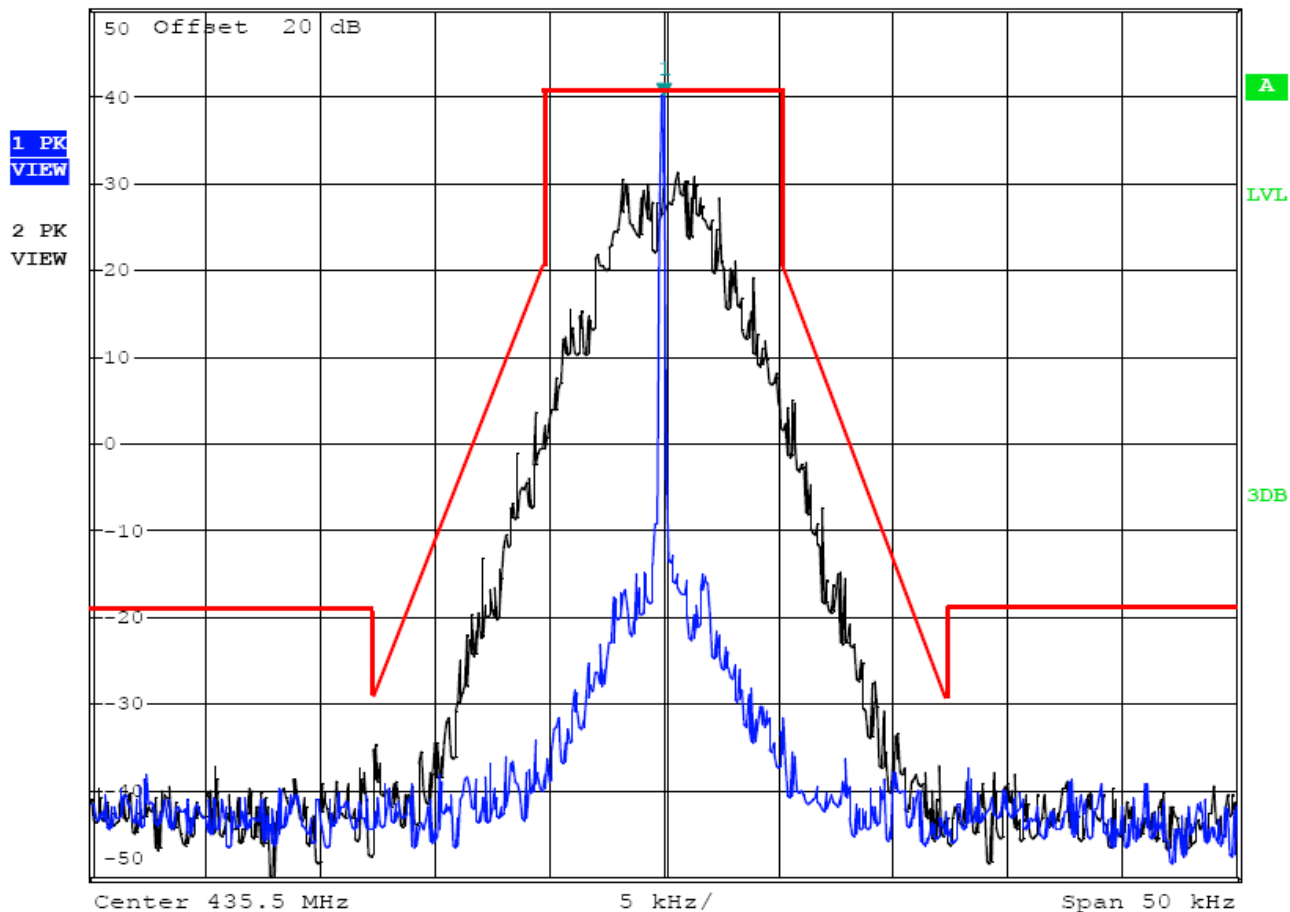

Date: 23.JAN.2013 15:40:47

12.5 kHz Channel Spacing, 435.5000 MHz, 4FSK Modulation Only

Modulation Type	Channel Separation	Freq.(MHz)	IC Applicable Mask	RBW	Audio Freq. (KHz)	Results
4FSK	12.5 KHz	453.0000	D	100Hz	/	Compliance

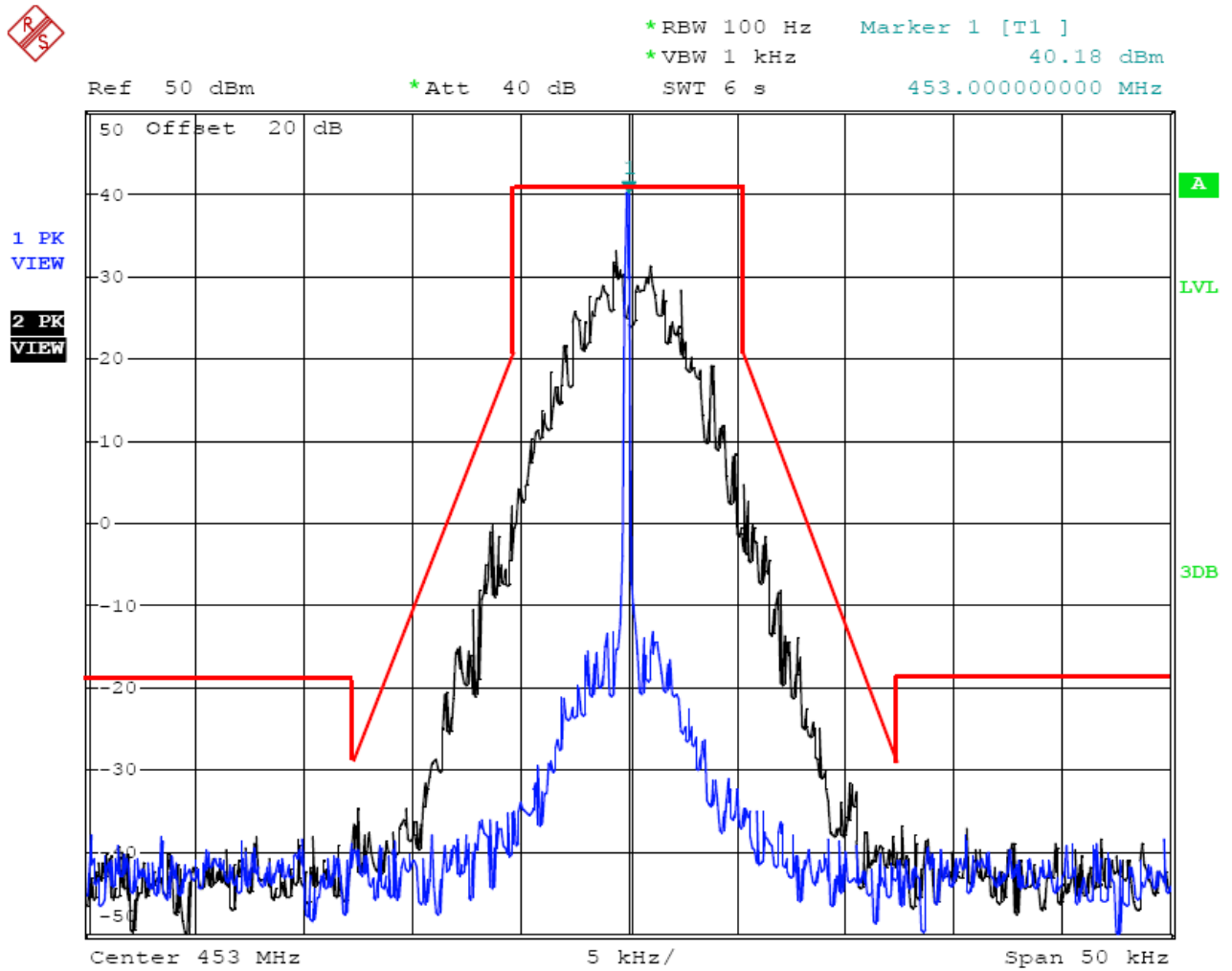

Date: 23.JAN.2013 15:38:40

12.5 kHz Channel Spacing, 453.0000 MHz, 4FSK Modulation Only

Modulation Type	Channel Separation	Freq.(MHz)	IC Applicable Mask	RBW	Audio Freq. (KHz)	Results
4FSK	12.5 KHz	469.5000	D	100Hz	/	Compliance

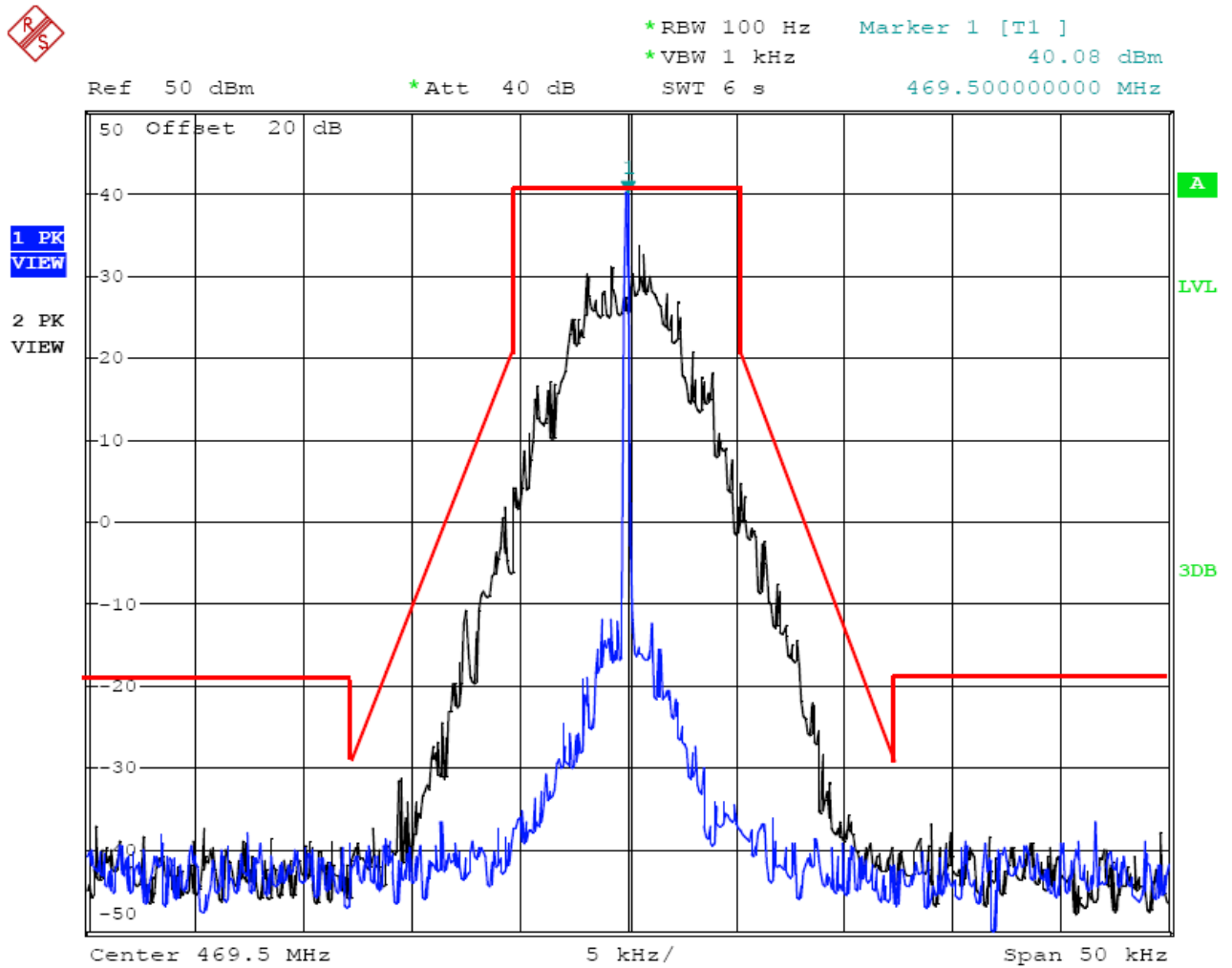

Date: 23.JAN.2013 15:35:47

12.5 kHz Channel Spacing, 469.5000 MHz, 4FSK Modulation Only

4.2.3 Occupied Bandwidth at Repeater function

TEST APPLICABLE

(a). Occupied Bandwidth: The spectral shape of outpyt should look similar to input for all modulations.

TEST CONFIGURATION

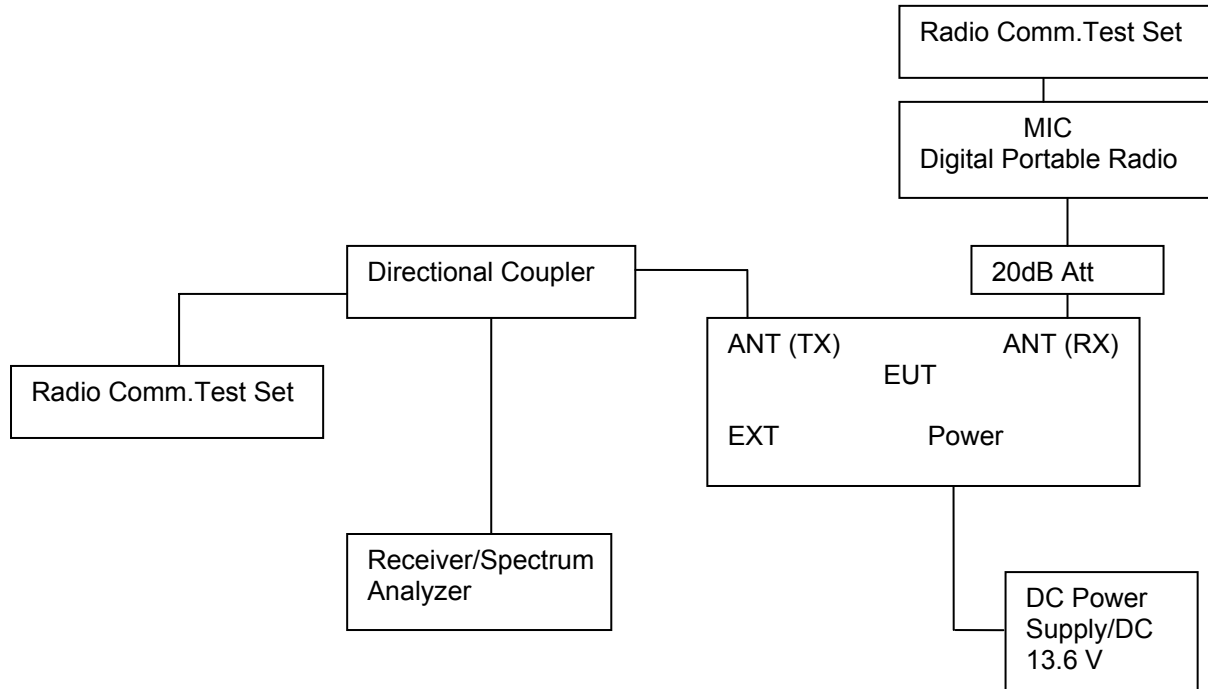

TEST PROCEDURE

- 1 The EUT was placed on a turn table which is 0.8m above ground plane.
- 2 The Digital Portable Radio was modulated by 2.5 KHz Sine wave audio signal or Digital sigal; the level of the audio signal employed is 16 dB greater than that necessary to produce 50% of rated system deviation. Rated system deviation is 2.5 kHz (12.5 kHz channel spacing) and 5 kHz (25 kHz channel spacing).
- 3 Set EUT as normal operation.
- 4 Set SPA Center Frequency = fundamental frequency, RBW=300Hz, VBW= 3 KHz, span =50 KHz.
- 5 Set SPA Max hold. Mark peak, Set 99% Occupied Bandwidth and 26dB Occupied Bandwidth.
- 6 Set SPA Center Frequency=fundamental frequency, RBW=300Hz, VBW=3 KHz span=50 KHz for 25 KHz channel spacing, while RBW=100Hz, VBW=300Hz, span=50 KHz for 12.5 channel spacing.

TEST RESULTS

4.2.3.1 Occupied Bandwidth of Digital Portable Radio

Modulation Type	Channel Sparation	Test Channel	Test Frequency	99% Occupied Bandwidth	26dB Occupied Bandwidth
FM	12.5KHz	Low	406.5000 MHz	9.80 KHz	10.60 KHz
		Low	418.0000 MHz	9.80 KHz	10.60 KHz
		Middle	435.5000 MHz	9.80 KHz	10.60 KHz
		High	453.0000 MHz	9.80 KHz	10.60 KHz
		High	469.5000 MHz	9.80 KHz	10.60 KHz
4FSK	12.5KHz	Low	406.5000 MHz	8.20 KHz	10.60 KHz
		Low	418.0000 MHz	8.00 KHz	10.30 KHz
		Middle	435.5000 MHz	7.70 KHz	9.50 KHz
		High	453.0000 MHz	7.90 KHz	9.80 KHz
		High	469.5000 MHz	7.80 KHz	10.30 KHz
Limit		11.25KHz for 12.5KHz Channel Separation			
Test Results		Compliance			

Plots of 99% and 26dB Bandwidth Measurement

Modulation Type	Channel Separation	Freq.(MHz)	99% Bandwidth (KHz)	26dB Bandwidth (KHz)	FCC Limit (KHz)	Results
FM	12.5 KHz	406.5000	9.80	10.60	11.25	Compliance

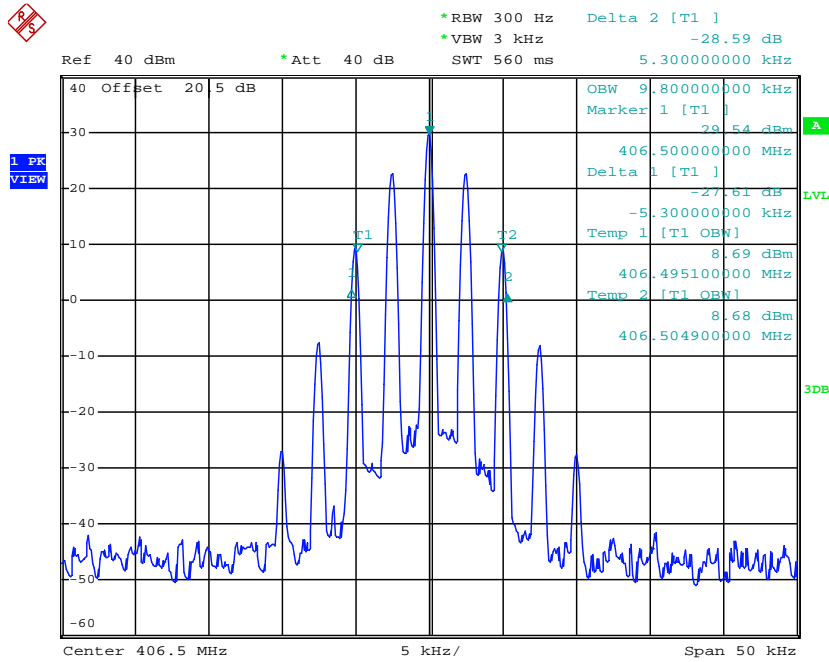

Date: 8.MAR.2013 09:28:01

Modulation Type	Channel Separation	Freq.(MHz)	99% Bandwidth (KHz)	26dB Bandwidth (KHz)	FCC Limit (KHz)	Results
FM	12.5 KHz	418.0000	9.80	10.60	11.25	Compliance

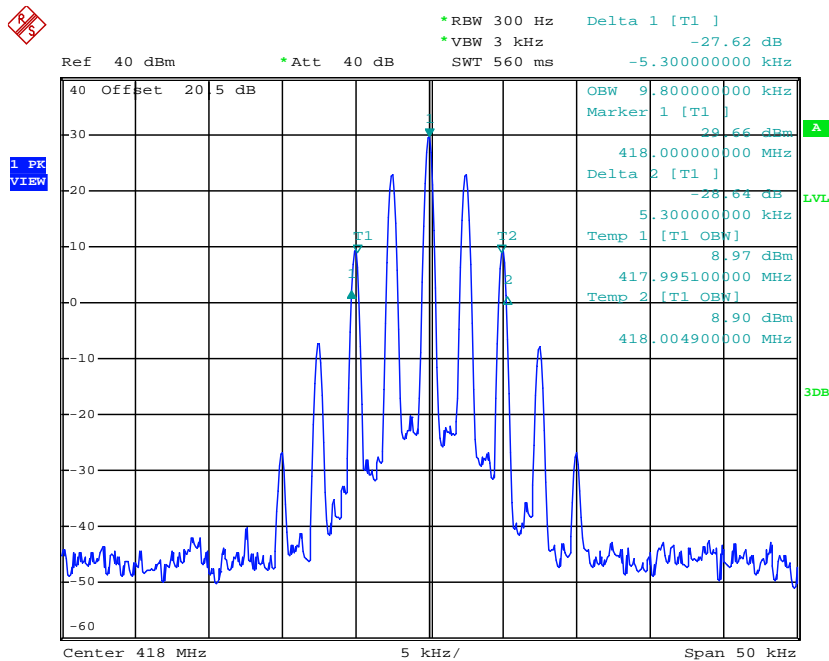

Date: 8.MAR.2013 09:28:44

Modulation Type	Channel Separation	Freq.(MHz)	99% Bandwidth (KHz)	26dB Bandwidth (KHz)	FCC Limit (KHz)	Results
FM	12.5 KHz	435.50000	9.80	10.60	11.25	Compliance

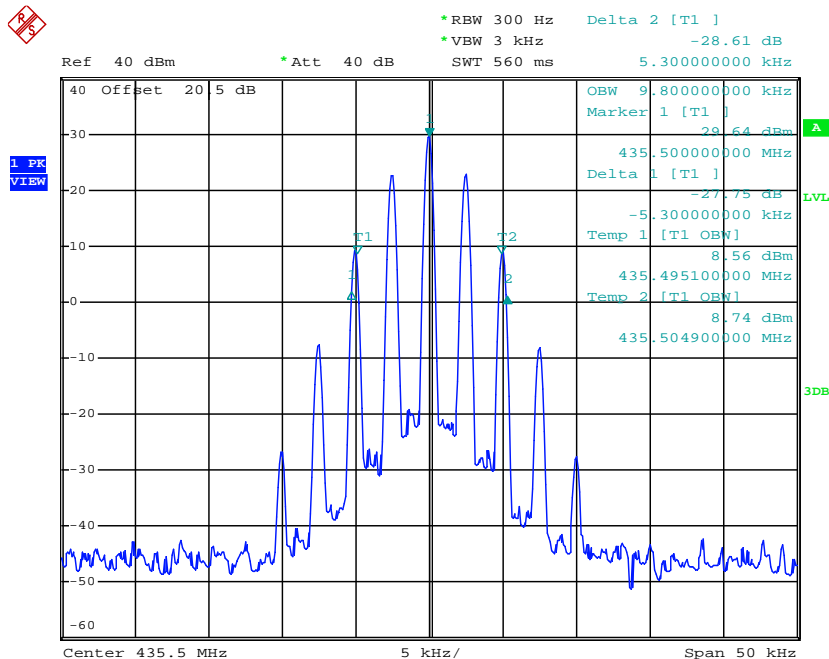

Date: 8.MAR.2013 09:29:38

Modulation Type	Channel Separation	Freq.(MHz)	99% Bandwidth (KHz)	26dB Bandwidth (KHz)	FCC Limit (KHz)	Results
FM	12.5 KHz	453.00000	9.80	10.60	11.25	Compliance

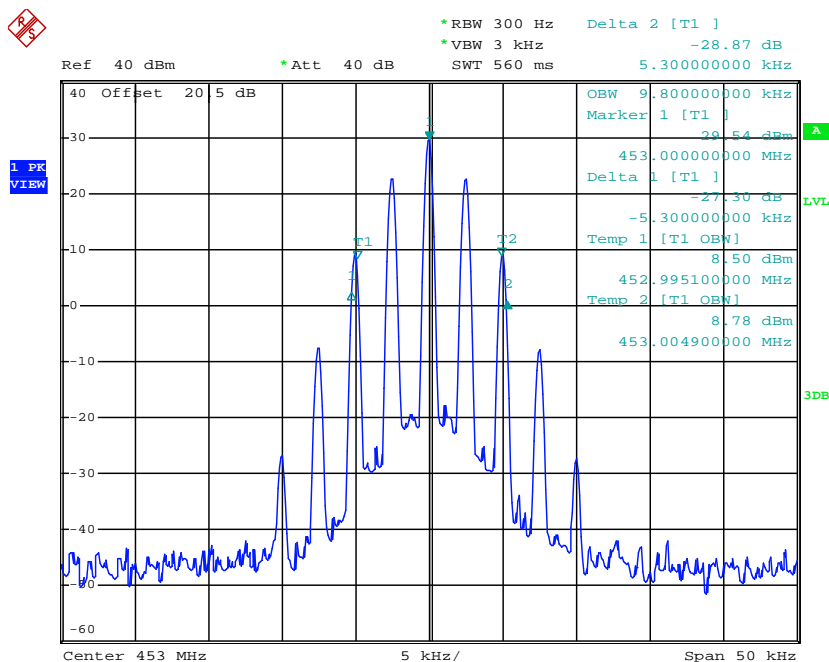

Date: 8.MAR.2013 09:30:30

Modulation Type	Channel Separation	Freq.(MHz)	99% Bandwidth (KHz)	26dB Bandwidth (KHz)	FCC Limit (KHz)	Results
FM	12.5 KHz	469.5000	9.80	10.60	11.25	Compliance

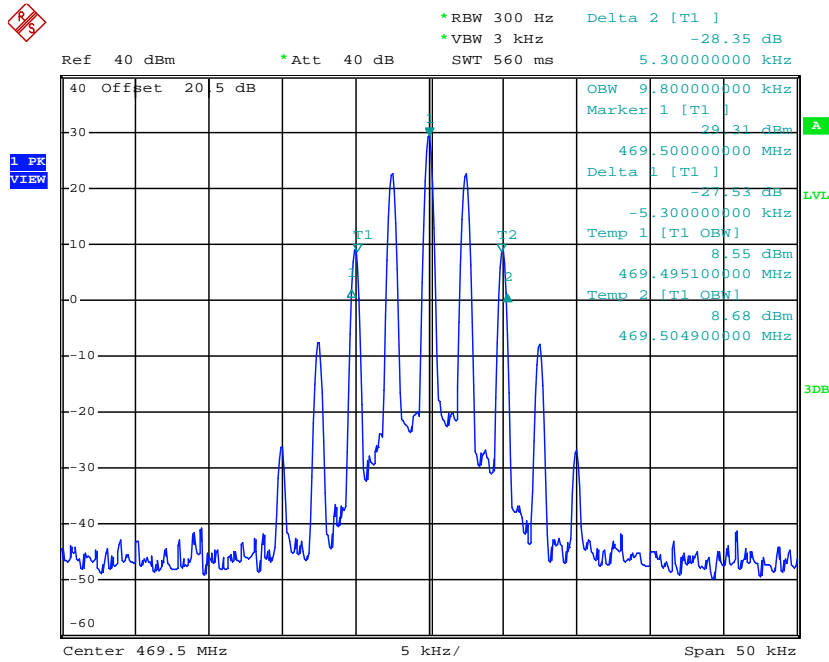

Date: 8.MAR.2013 09:31:14

Modulation Type	Channel Separation	Freq.(MHz)	99% Bandwidth (KHz)	26dB Bandwidth (KHz)	FCC Limit (KHz)	Results
4FSK	12.5 KHz	406.5000	8.20	10.60	11.25	Compliance

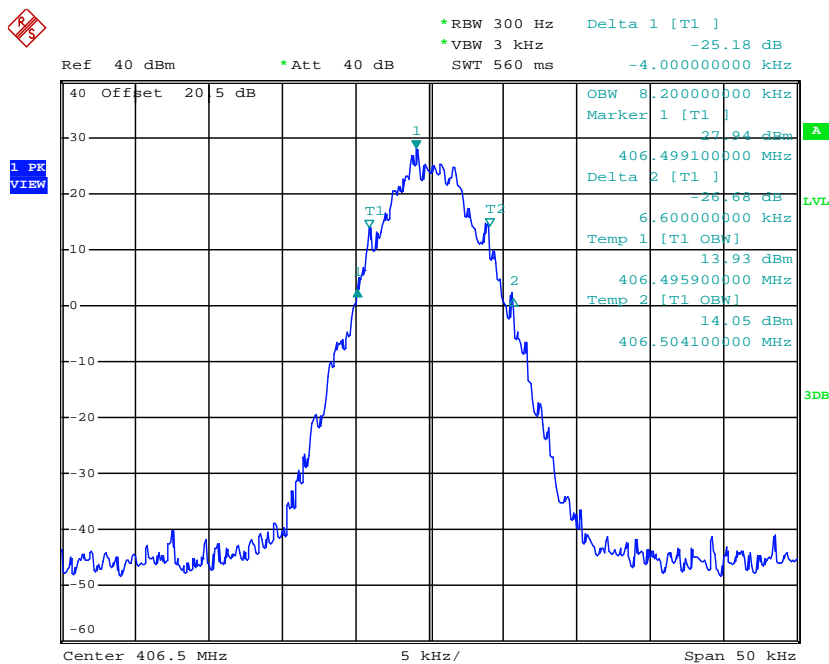

Date: 8.MAR.2013 10:25:52

Modulation Type	Channel Separation	Freq.(MHz)	99% Bandwidth (KHz)	26dB Bandwidth (KHz)	FCC Limit (KHz)	Results
4FSK	12.5 KHz	418.0000	8.00	10.30	11.25	Compliance

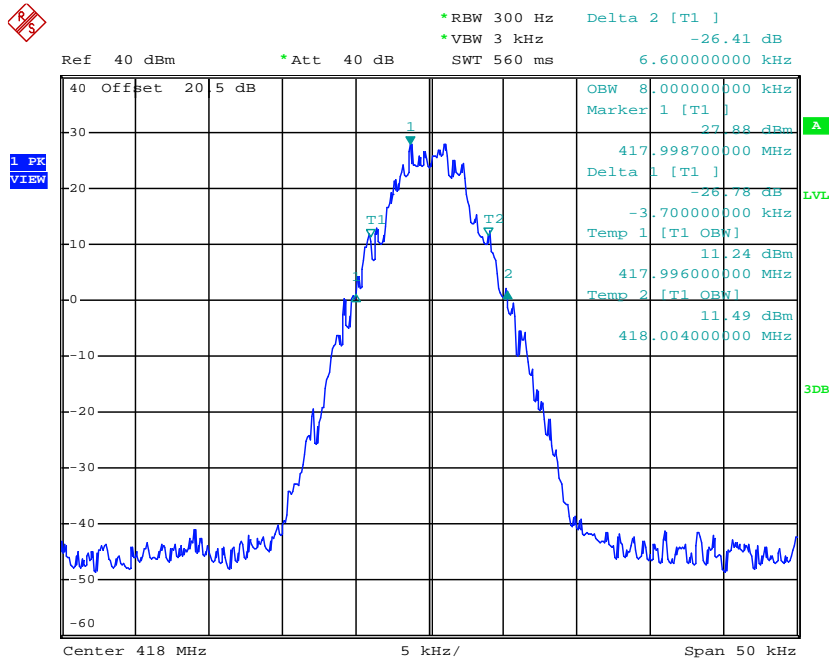

Date: 8.MAR.2013 10:23:50

Modulation Type	Channel Separation	Freq.(MHz)	99% Bandwidth (KHz)	26dB Bandwidth (KHz)	FCC Limit (KHz)	Results
4FSK	12.5 KHz	435.5000	7.70	9.50	11.25	Compliance

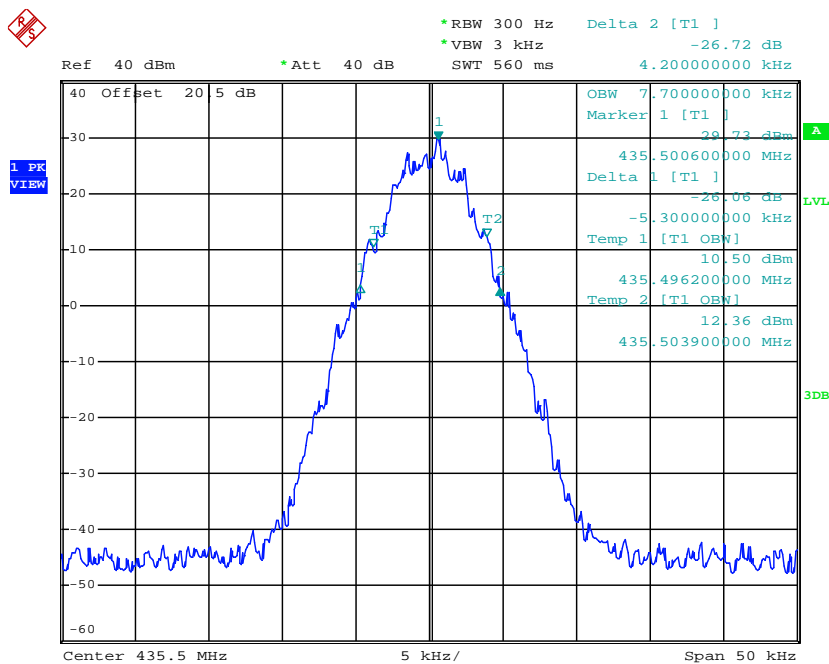

Date: 8.MAR.2013 10:22:40

Modulation Type	Channel Separation	Freq.(MHz)	99% Bandwidth (KHz)	26dB Bandwidth (KHz)	FCC Limit (KHz)	Results
4FSK	12.5 KHz	453.0000	7.90	9.80	11.25	Compliance

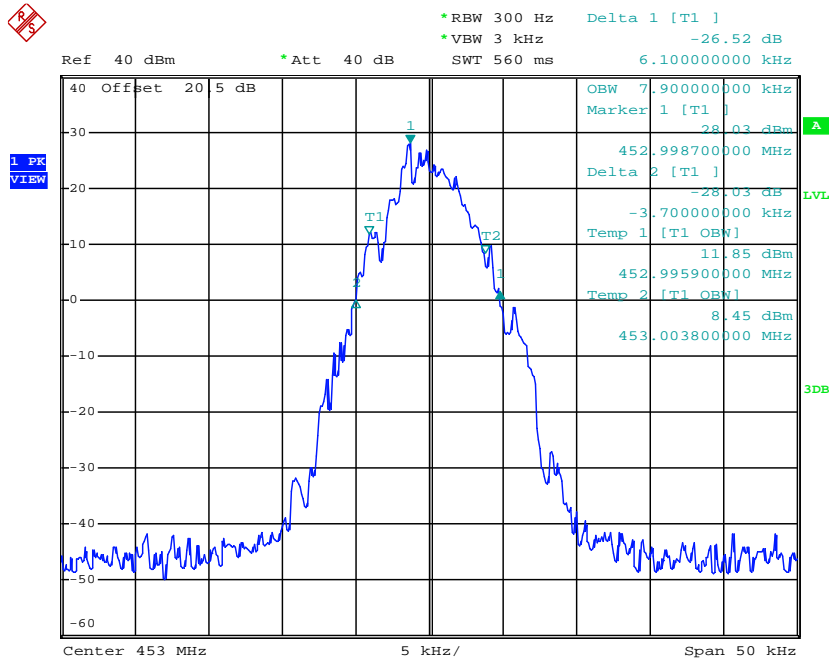

Date: 8.MAR.2013 10:21:47

Modulation Type	Channel Separation	Freq.(MHz)	99% Bandwidth (KHz)	26dB Bandwidth (KHz)	FCC Limit (KHz)	Results
4FSK	12.5 KHz	469.5000	7.80	10.30	11.25	Compliance

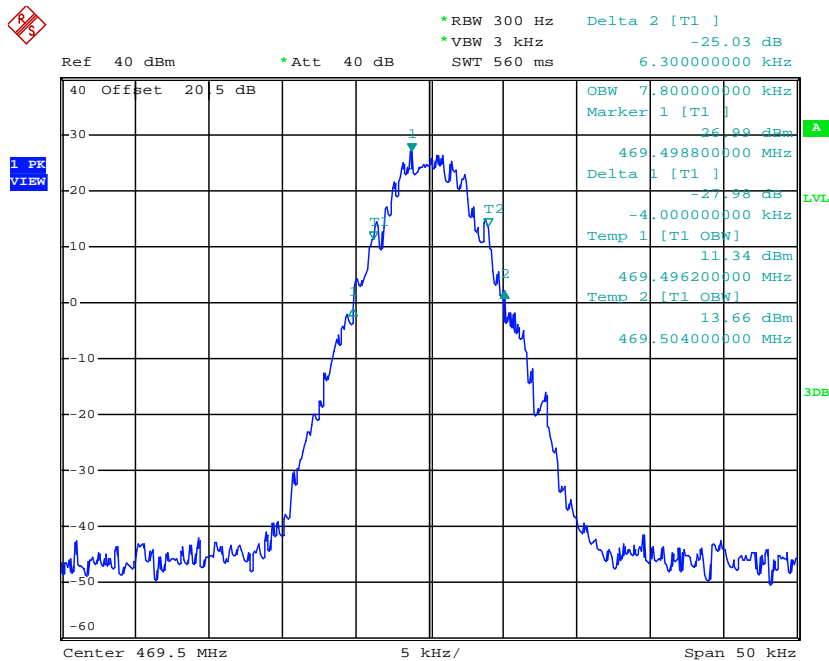

Date: 8.MAR.2013 10:20:24

4.2.3.2 Occupied Bandwidth of EUT

Modulation Type	Channel Separation	Test Channel	Test Frequency	99% Occupied Bandwidth	26dB Occupied Bandwidth
FM	12.5KHz	Low	406.5000 MHz	9.80 KHz	10.60 KHz
		Low	418.0000 MHz	9.80 KHz	10.60 KHz
		Middle	435.5000 MHz	9.80 KHz	10.60 KHz
		High	453.0000 MHz	9.80 KHz	10.60 KHz
		High	469.5000 MHz	9.80 KHz	10.60 KHz
4FSK	12.5KHz	Low	406.5000 MHz	7.30 KHz	10.50 KHz
		Low	418.0000 MHz	8.10 KHz	10.30 KHz
		Middle	435.5000 MHz	7.90 KHz	10.50 KHz
		High	453.0000 MHz	7.10 KHz	10.40 KHz
		High	469.5000 MHz	7.90 KHz	9.70 KHz
Limit			11.25KHz for 12.5KHz Channel Separation		
Test Results			Compliance		

Plots of 99% and 26dB Bandwidth Measurement

Modulation Type	Channel Separation	Freq.(MHz)	99% Bandwidth (KHz)	26dB Bandwidth (KHz)	FCC Limit (KHz)	Results
FM	12.5 KHz	406.5000	9.80	10.60	11.25	Compliance

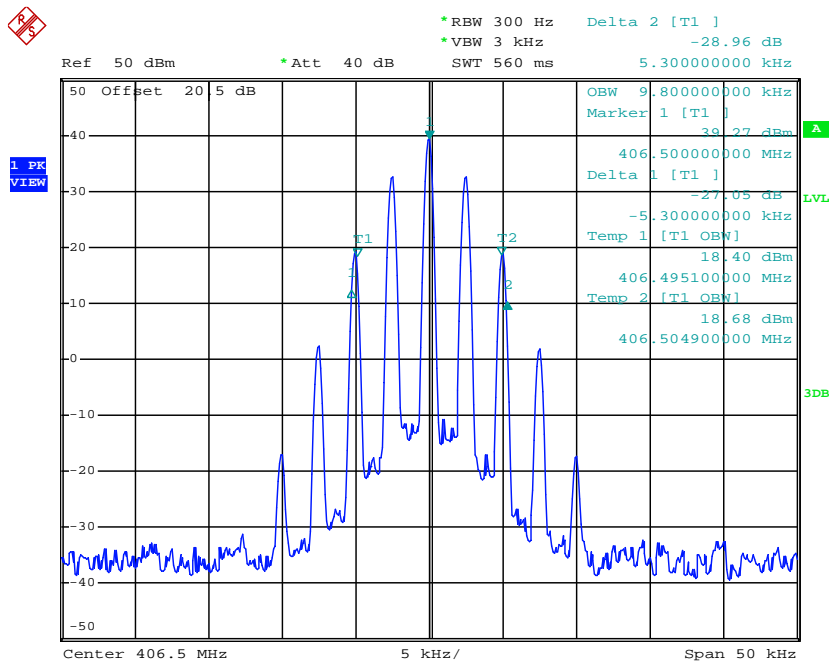

Date: 8.MAR.2013 09:23:32

Modulation Type	Channel Separation	Freq.(MHz)	99% Bandwidth (KHz)	26dB Bandwidth (KHz)	FCC Limit (KHz)	Results
FM	12.5 KHz	418.0000	9.80	10.60	11.25	Compliance

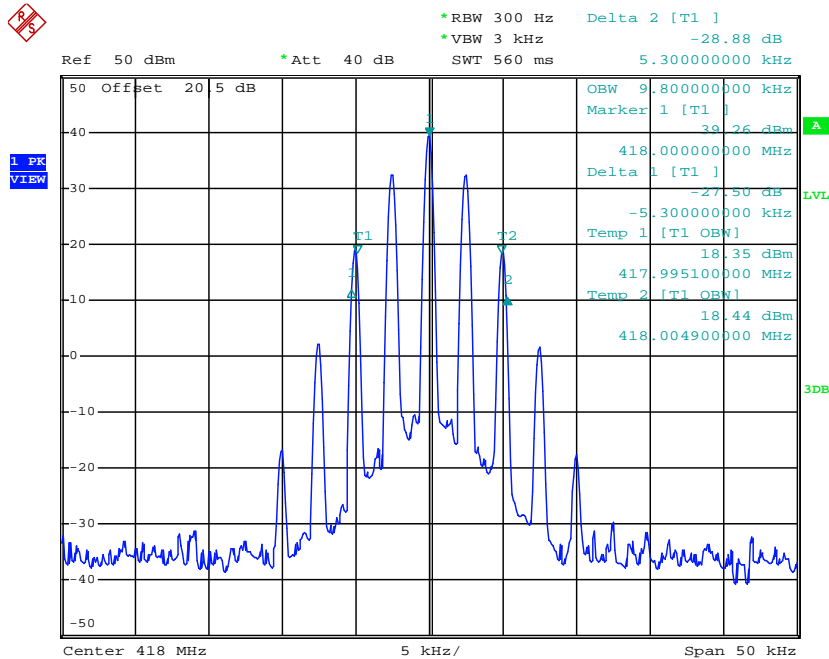

Date: 8.MAR.2013 09:24:12

Modulation Type	Channel Separation	Freq.(MHz)	99% Bandwidth (KHz)	26dB Bandwidth (KHz)	FCC Limit (KHz)	Results
FM	12.5 KHz	435.5000	9.80	10.60	11.25	Compliance

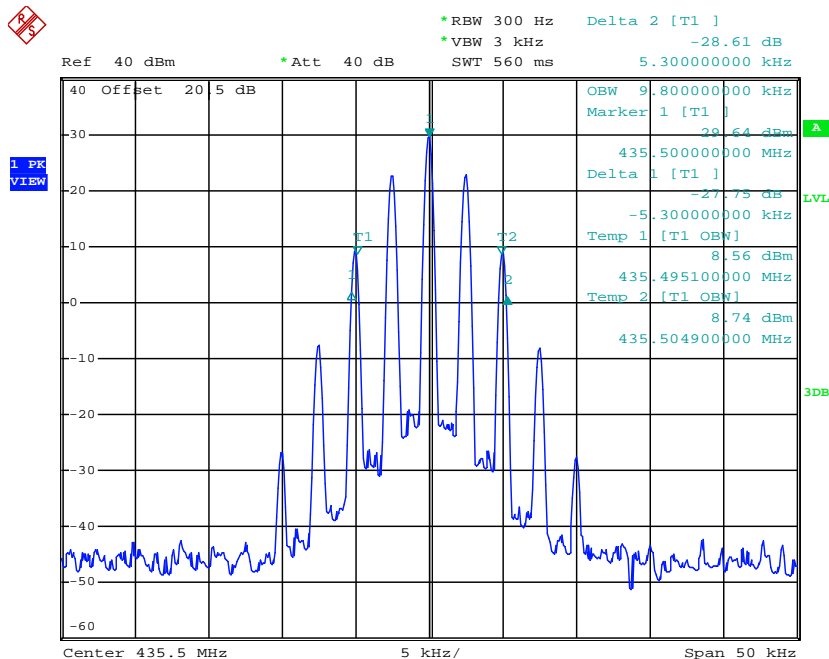

Date: 8.MAR.2013 09:29:38

Modulation Type	Channel Separation	Freq.(MHz)	99% Bandwidth (KHz)	26dB Bandwidth (KHz)	FCC Limit (KHz)	Results
FM	12.5 KHz	453.0000	9.80	10.60	11.25	Compliance

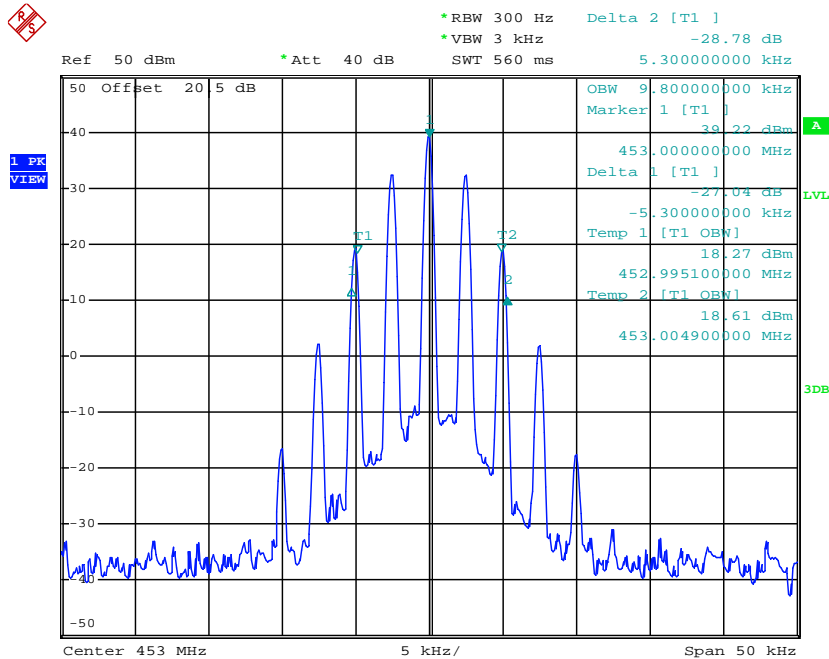

Date: 8.MAR.2013 09:26:15

Modulation Type	Channel Separation	Freq.(MHz)	99% Bandwidth (KHz)	26dB Bandwidth (KHz)	FCC Limit (KHz)	Results
FM	12.5 KHz	469.5000	9.80	10.60	11.25	Compliance

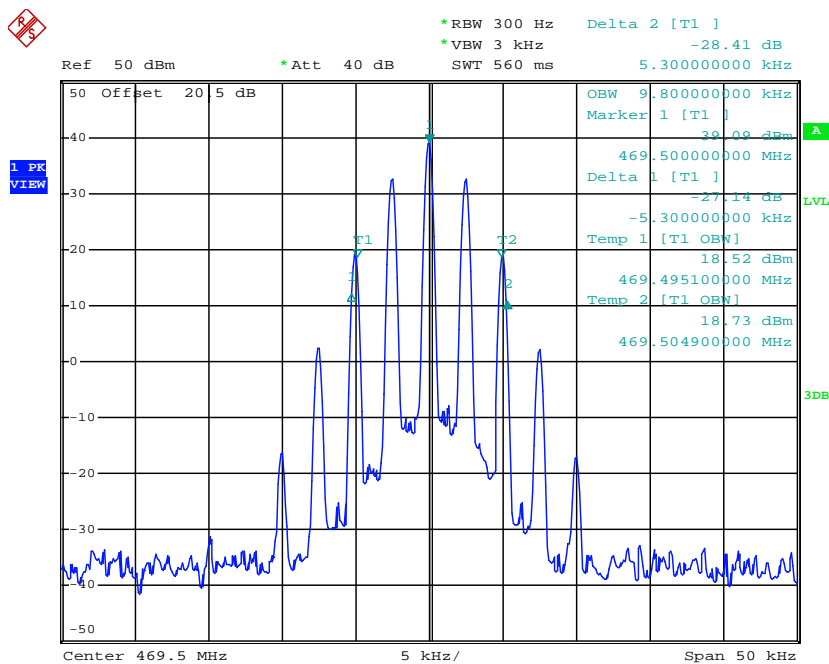

Date: 8.MAR.2013 09:27:04

Modulation Type	Channel Separation	Freq.(MHz)	99% Bandwidth (KHz)	26dB Bandwidth (KHz)	FCC Limit (KHz)	Results
4FSK	12.5 KHz	406.5000	7.30	10.50	11.25	Compliance

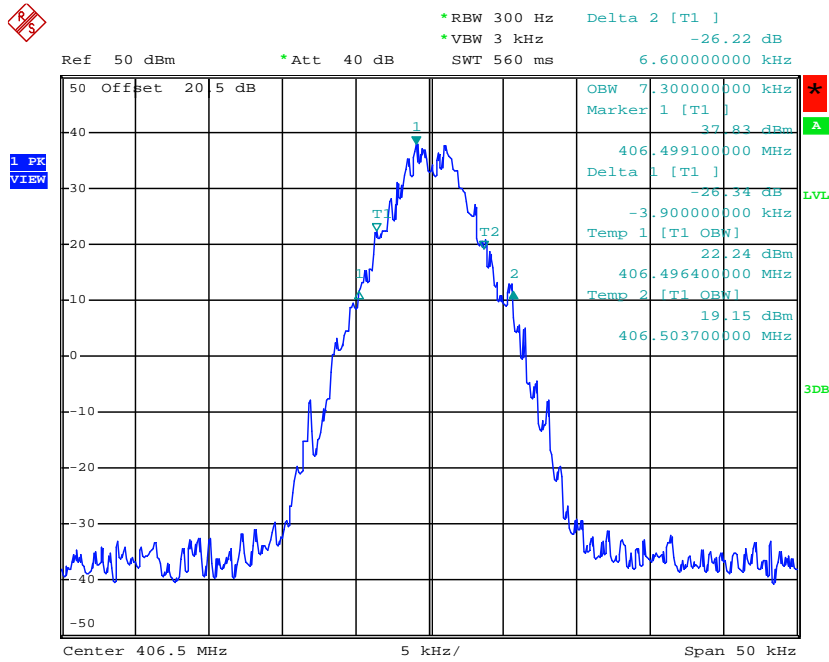

Date: 8.MAR.2013 10:11:30

Modulation Type	Channel Separation	Freq.(MHz)	99% Bandwidth (KHz)	26dB Bandwidth (KHz)	FCC Limit (KHz)	Results
4FSK	12.5 KHz	418.0000	8.10	10.30	11.25	Compliance

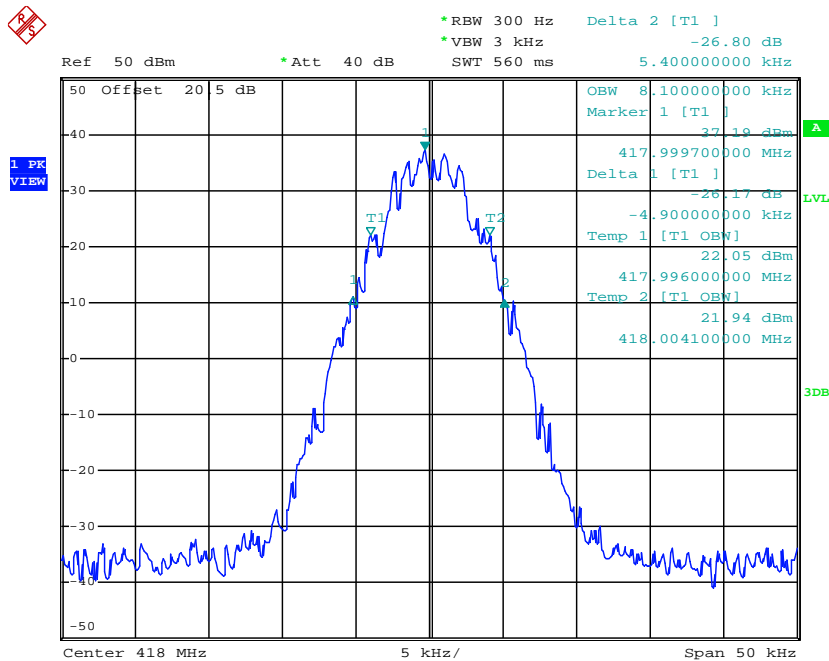

Date: 8.MAR.2013 10:12:37

Modulation Type	Channel Separation	Freq.(MHz)	99% Bandwidth (KHz)	26dB Bandwidth (KHz)	FCC Limit (KHz)	Results
4FSK	12.5 KHz	435.5000	7.90	10.50	11.25	Compliance

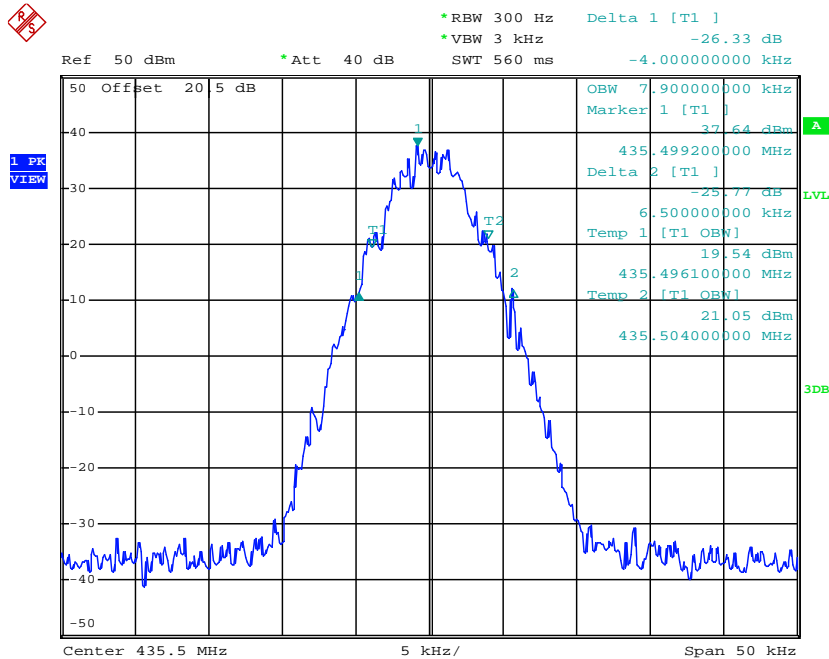

Date: 8.MAR.2013 10:13:57

Modulation Type	Channel Separation	Freq.(MHz)	99% Bandwidth (KHz)	26dB Bandwidth (KHz)	FCC Limit (KHz)	Results
4FSK	12.5 KHz	453.0000	7.10	10.40	11.25	Compliance

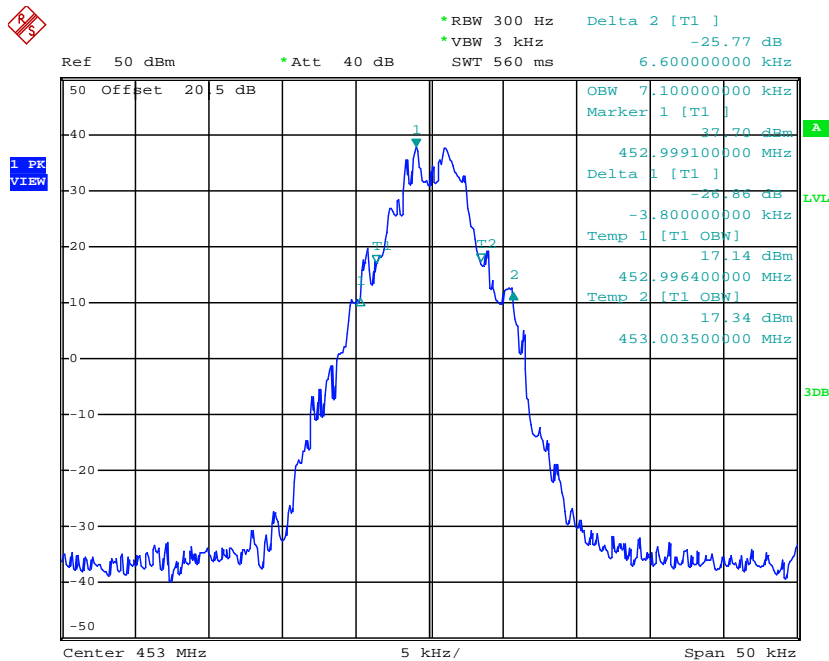

Date: 8.MAR.2013 10:15:06

Modulation Type	Channel Separation	Freq.(MHz)	99% Bandwidth (KHz)	26dB Bandwidth (KHz)	FCC Limit (KHz)	Results
4FSK	12.5 KHz	469.5000	7.90	9.70	11.25	Compliance

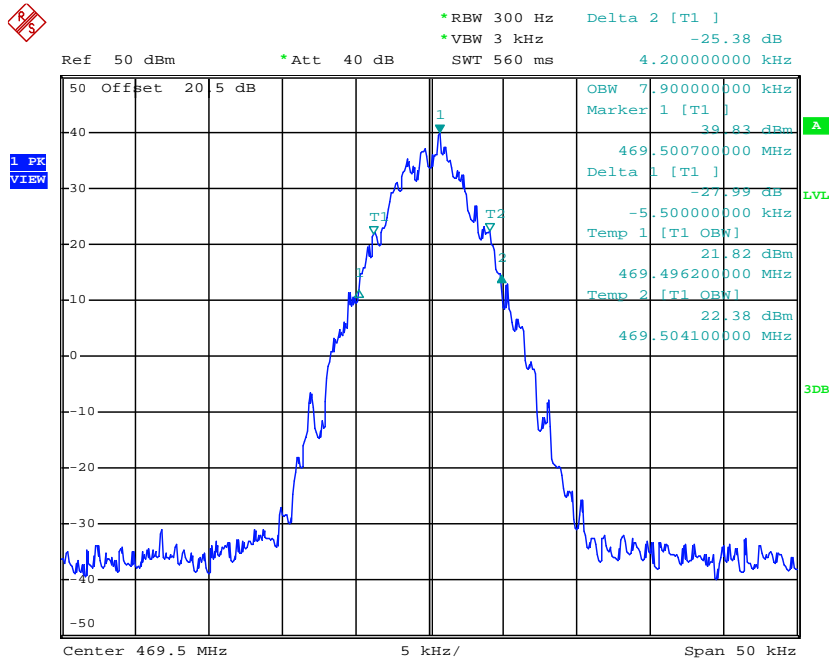

Date: 8.MAR.2013 10:16:33

4.3. Transmitter Radiated Spurious Emission

TEST APPLICABLE

According to the TIA/EIA 603 test method, and according to Section 90.210, the power of each unwanted emission shall be less than Transmitted Power as specified below for transmitters designed to operate with 12.5 KHz channel bandwidth:

- 1 On any frequency removed from the center of the authorized bandwidth f_0 to 5.625 KHz removed from f_0 : Zero dB
 - 2 On any frequency removed from the center of the authorized bandwidth by a displacement frequency (f_d in KHz) f_0 of more than 5.625 KHz but no more than 12.5 KHz: At least 7.27dB
 - 3 On any frequency removed from the center of the authorized bandwidth by a displacement frequency (f_d in KHz) f_0 of more than 12.5 KHz: At least $50+10 \log (P)$ dB or 70 dB, which ever is lesser attenuation.
- For transmitters designed to transmit with 25 KHz channel separation and equipped with an audio low-pass filter, the power of any emission must be attenuated below the unmodulated carrier power (P) as following:

- 1 On any frequency removed from the assigned frequency by more than 50 percent, but no more than 100 percent of the authorized bandwidth: At least 25 dB.
- 2 On any frequency removed from the assigned frequency by more than 100 percent, but no more than 250 percent of the authorized bandwidth: At least 35 dB.
- 3 On any frequency removed from the assigned frequency by more than 250 percent of the authorized bandwidth: At least $43+10\log (P)$ dB.

TEST CONFIGURATION

Below 1GHz

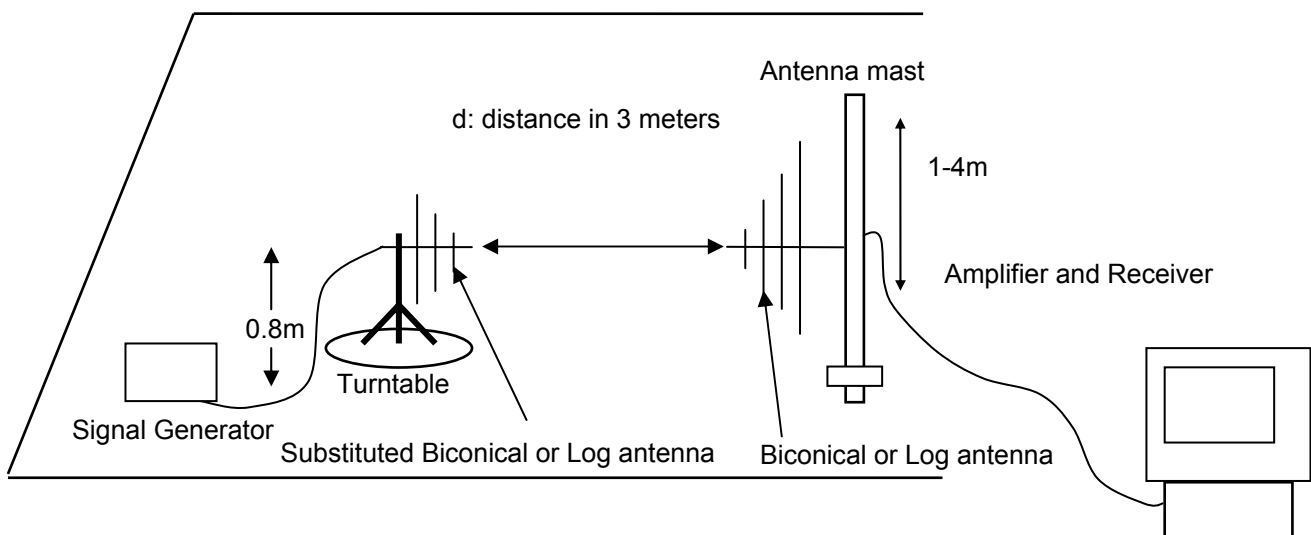
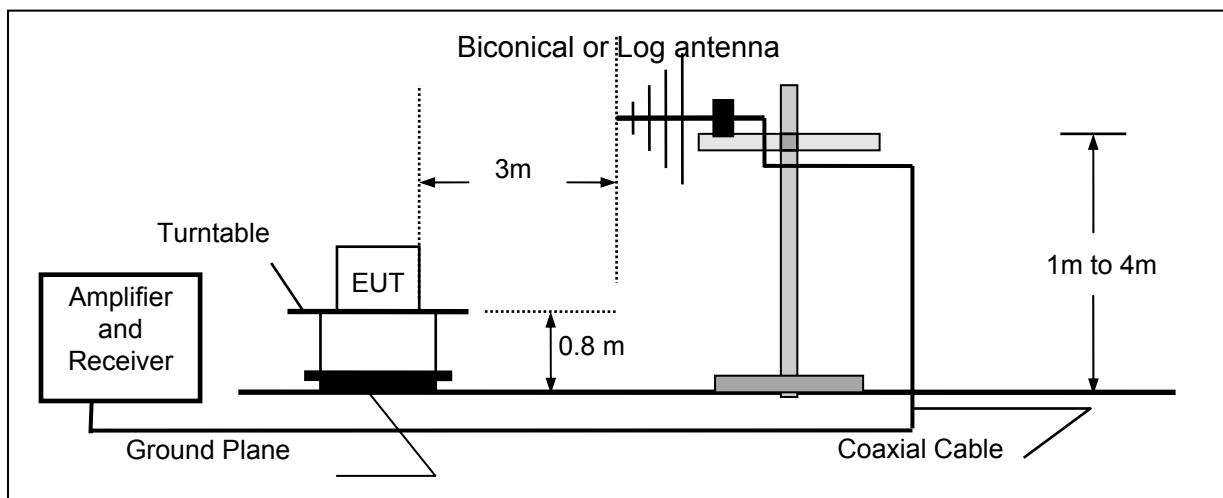

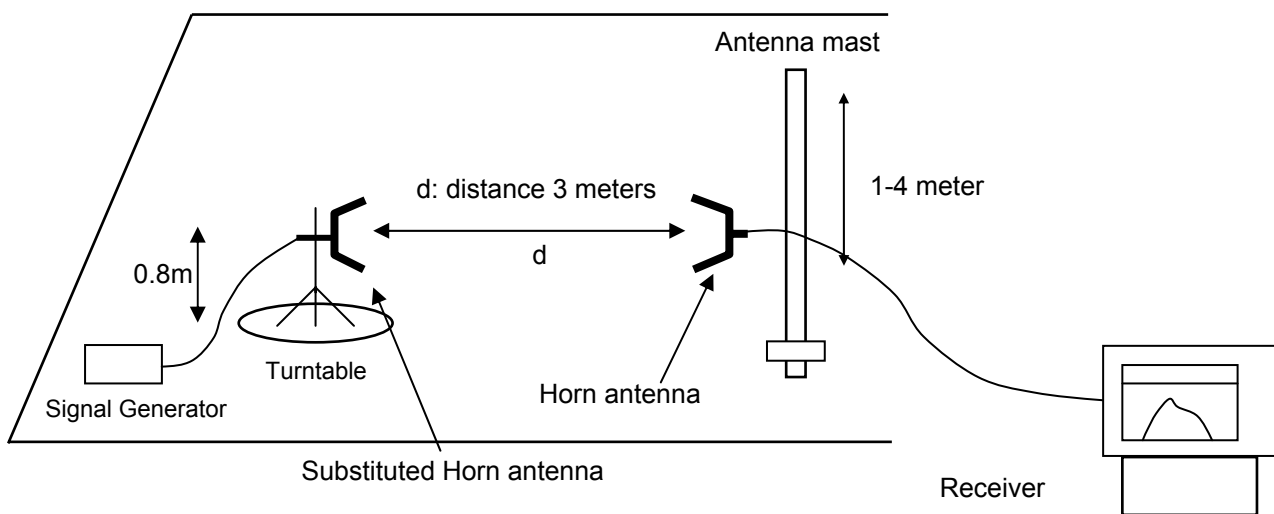
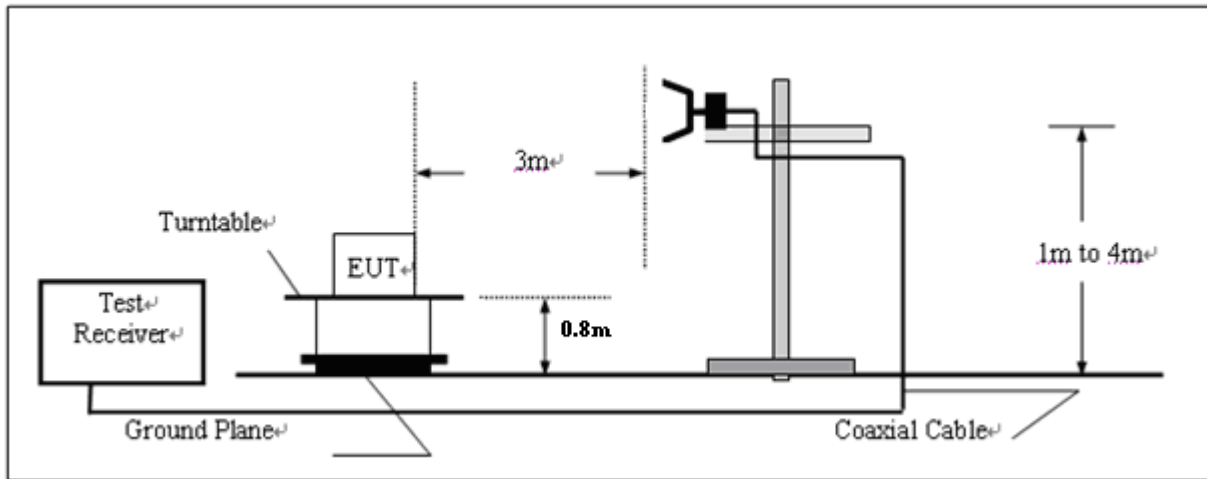
Above 1GHz**TEST PROCEDURE**

- 1 Set the EMI Receiver (for measuring E-Field) and Receiver (for measuring EIRP) as follows:
Center Frequency: equal to the signal source
Resolution BW: 100 KHz
Video BW: VBW > RBW
Detector Mode: positive
Average: off
Span: 3 x the signal bandwidth
- 2 Load an appropriate correction factors file in EMI Receiver for correcting the field strength reading level
Total Correction Factor recorded in the EMI Receiver = Cable Loss + Antenna Factor + Amplifier Gain
 $E \text{ (dBuV/m)} = \text{Reading (dBuV)} + \text{Total Correction Factor (dB)}$
- 3 The transmitter under test was placed at the specified height on a non-conducting turntable (80 cm height)
- 4 Substitute the EUT by a signal generator and one of the following transmitting antenna (substitution antenna):
DIPOLE antenna for frequency from 30-1000 MHz or
HORN antenna for frequency above 1 GHz}.
- 5 Mount the transmitting antenna at 1.0 meter high from the ground plane.
- 6 Use one of the following antenna as a receiving antenna:
DIPOLE antenna for frequency from 30-1000 MHz or
HORN antenna for frequency above 1 GHz}.
- 7 If the DIPOLE antenna is used, tune it's elements to the frequency as specified in the calibration manual.
- 8 Adjust both transmitting and receiving antenna in a VERTICAL polarization.
- 9 Tune the EMI Receivers to the test frequency.
- 10 Lower or raise the test antenna from 1 to 4 meters until the maximum signal level was detected.
- 11 The transmitter was rotated through 360° about a vertical axis until a higher maximum signal was received.

- 12 Lower or raise the test antenna from 1 to 4 meters until the maximum signal level was detected.
 - 13 Adjust input signal to the substitution antenna until an equal or a known related level to that detected from the transmitter was obtained in the test receiver.
 - 14 Record the power level read from the Average Power Meter and calculate the ERP/EIRP as follows:

$$P = P_1 - L_1 = (P_2 + L_2) - L_1 = P_3 + A + L_2 - L_1$$

$$\text{EIRP} = P + G_1 = P_3 + L_2 - L_1 + A + G_1$$

$$\text{ERP} = \text{EIRP} - 2.15 \text{ dB}$$

$$\text{Total Correction factor in EMI Receiver} = L_2 - L_1 + G_1$$
- Where:
- P: Actual RF Power fed into the substitution antenna port after corrected.
 - P₁: Power output from the signal generator
 - P₂: Power measured at attenuator A input
 - P₃: Power reading on the Average Power Meter
 - EIRP: EIRP after correction
 - ERP: ERP after correction
- 15 Adjust both transmitting and receiving antenna in a Horizontal polarization, then repeat step (11) to (14).
 - 16 Repeat step (4) to (16) for different test frequency
 - 17 Repeat steps (3) to (12) with the substitution antenna oriented in horizontal polarization.
 - 18 Actual gain of the EUT's antenna is the difference of the measured EIRP and measured RF power at the RF port. Correct the antenna gain if necessary.

TEST RESULTS

The Transmitter Radiated Spurious Emission was performed to the Rated high power (10Watt) and Rated low power (1Watt) the datum that reported below is the worst case (Rated high power) of the two rated power conditions.

Modulation Type: FM

FCC Part 22.359, 74.462, 80.211 and 90.210 and RSS Gen, RSS 119 Issue 11 (12.5 kHz bandwidth only): On any frequency removed from the center of the authorized bandwidth by a displacement frequency (f d in kHz) of more than 12.5 kHz at least:

Low: $50 + 10 \log (\text{Pwatts}) = 50 + 10 \log (10.16) = 60.07 \text{ dB}$

High: $50 + 10 \log (\text{Pwatts}) = 50 + 10 \log (10.72) = 60.30 \text{ dB}$

Note: In general, the worse case attenuation requirement shown above was applied.

Calculation: Limit (dBm) = EL-50-10log10 (TP)

Notes: EL is the emission level of the Output Power expressed in dBm,

In this application, the EL is 40.30 dBm.

Limit (dBm) = 40.30-50-10log10 (10.72) = -20 dBm

Modulation Type: 4FSK

FCC Part 22.359, 74.462, 80.211 and 90.210 and RSS Gen, RSS 119 Issue 11 (12.5 kHz Bandwidth only):

On any frequency removed from the center of the authorized bandwidth by a displacement frequency (f d in kHz) of more than 12.5 kHz at least:

Low: $50 + 10 \log (\text{Pwatts}) = 50 + 10 \log (10.57) = 60.24 \text{ dB}$

High: $50 + 10 \log (\text{Pwatts}) = 50 + 10 \log (10.99) = 60.41 \text{ dB}$

Note: In general, the worse case attenuation requirement shown above was applied.

Calculation: Limit (dBm) = EL-50-10log10 (TP)

Notes: EL is the emission level of the Output Power expressed in dBm,

In this application, the EL is 40.41 dBm.

Limit (dBm) = 40.41-50-10log10 (10.99) = -20 dBm

Note: 1. In general, the worse case attenuation requirement shown above was applied.

2. The measurement frequency range from 30 MHz to 4 GHz.

3. *** means that the emission level is too low to be measured or at least 20 dB down than the limit.

Modulation		FM		Channel Separation		12.5KHz		
Test Channel		Low Channel		Test Frequency		406.5000 MHz		
Frequency (MHz)	E-Field Level (dBuV/m)	EMI Detector (Peak/QP)	Antenna Polarization	Antenna Height (cm)	Table Angle (Degree)	ERP measured by Substitution Method (dBm)	Limit (dBm)	Margin (dB)
813.00	53.59	Peak	H	200	35	-41.61	-20	21.61
1219.50	50.16	Peak	H	150	142	-43.04	-20	23.04
1626.00	47.27	Peak	H	100	220	-47.83	-20	27.83
...	...		H					
813.00	54.87	Peak	V	150	351	-40.33	-20	20.33
1219.50	50.31	Peak	V	100	68	-44.29	-20	24.29
1626.00	46.94	Peak	V	120	158	-47.26	-20	27.26
...	...		V					

Modulation		FM		Channel Separation		12.5KHz		
Test Channel		Low Channel		Test Frequency		418.0000 MHz		
Frequency (MHz)	E-Field Level (dBuV/m)	EMI Detector (Peak/QP)	Antenna Polarization	Antenna Height (cm)	Table Angle (Degree)	ERP measured by Substitution Method (dBm)	Limit (dBm)	Margin (dB)
836.00	53.63	Peak	H	100	56	-41.57	-20	21.57
1254.00	50.47	Peak	H	120	235	-42.73	-20	22.73
1672.00	47.69	Peak	H	100	114	-47.41	-20	27.41
...	...		H					
836.00	54.98	Peak	V	120	205	-40.22	-20	20.22
1254.00	49.20	Peak	V	110	124	-45.40	-20	25.40
1672.00	46.27	Peak	V	120	198	-47.93	-20	27.93
...	...		V					

Modulation		FM		Channel Separation		12.5KHz		
Test Channel		Middle Channel		Test Frequency		435.5000 MHz		
Frequency (MHz)	E-Field Level (dBuV/m)	EMI Detector (Peak/QP)	Antenna Polarization	Antenna Height (cm)	Table Angle (Degree)	ERP measured by Substitution Method (dBm)	Limit (dBm)	Margin (dB)
871.00	54.49	Peak	H	100	247	-40.71	-20	20.71
1306.50	53.06	Peak	H	120	156	-40.14	-20	20.14
1742.00	45.49	Peak	H	100	325	-49.61	-20	29.61
...	...		H					
871.00	54.14	Peak	V	100	214	-41.06	-20	21.06
1306.50	52.17	Peak	V	100	52	-42.43	-20	22.43
1742.00	44.27	Peak	V	120	133	-49.93	-20	29.93
...	...		V					

Modulation		FM		Channel Separation		12.5KHz		
Test Channel		High Channel		Test Frequency		453.0000 MHz		
Frequency (MHz)	E-Field Level (dBuV/m)	EMI Detector (Peak/QP)	Antenna Polarization	Antenna Height (cm)	Table Angle (Degree)	ERP measured by Substitution Method (dBm)	Limit (dBm)	Margin (dB)
906.00	54.53	Peak	H	500	54	-40.67	-20	20.67
1359.00	53.37	Peak	H	150	132	-39.83	-20	19.83
1812.00	45.91	Peak	H	120	150	-49.19	-20	29.19
...	...		H					
906.00	54.25	Peak	V	150	144	-40.95	-20	20.95
1359.00	51.06	Peak	V	200	160	-43.54	-20	23.54
1812.00	43.16	Peak	V	120	257	-51.04	-20	31.04
...	...		V					

Modulation		FM		Channel Separation		12.5KHz		
Test Channel		High Channel		Test Frequency		469.5000 MHz		
Frequency (MHz)	E-Field Level (dBuV/m)	EMI Detector (Peak/QP)	Antenna Polarization	Antenna Height (cm)	Table Angle (Degree)	ERP measured by Substitution Method (dBm)	Limit (dBm)	Margin (dB)
939.00	53.53	Peak	H	220	235	-41.67	-20	21.67
1408.50	49.87	Peak	H	150	302	-43.33	-20	23.33
1878.00	44.29	Peak	H	210	75	-50.81	-20	30.81
...	...		H					
939.00	52.9	Peak	V	100	65	-42.30	-20	22.30
1408.50	49.94	Peak	V	120	195	-44.66	-20	24.66
1878.00	44.93	Peak	V	150	264	-49.27	-20	29.27
...	...		V					

Modulation		4FSK		Channel Separation		12.5KHz		
Test Channel		Low Channel		Test Frequency		406.5000 MHz		
Frequency (MHz)	E-Field Level (dBuV/m)	EMI Detector (Peak/QP)	Antenna Polarization	Antenna Height (cm)	Table Angle (Degree)	ERP measured by Substitution Method (dBm)	Limit (dBm)	Margin (dB)
813.00	54.12	Peak	H	120	63	-41.08	-20	21.08
1219.50	54.47	Peak	H	200	41	-38.73	-20	18.73
1626.00	47.27	Peak	H	110	321	-47.83	-20	27.83
...	...		H					
813.00	54.97	Peak	V	110	144	-40.23	-20	20.23
1219.50	54.58	Peak	V	120	125	-40.02	-20	20.02
1626.00	46.89	Peak	V	100	105	-47.31	-20	27.31
...	...		V					

Modulation		4FSK		Channel Separation		12.5KHz		
Test Channel		Low Channel		Test Frequency		418.0000 MHz		
Frequency (MHz)	E-Field Level (dBuv/m)	EMI Detector (Peak/QP)	Antenna Polarization	Antenna Height (cm)	Table Angle (Degree)	ERP measured by Substitution Method (dBm)	Limit (dBm)	Margin (dB)
836.00	53.75	Peak	H	120	126	-41.45	-20	21.45
1254.00	54.78	Peak	H	150	134	-38.42	-20	18.42
1672.00	48.00	Peak	H	200	154	-47.10	-20	27.10
...	...		H					
836.00	54.60	Peak	V	150	214	-40.60	-20	20.60
1254.00	54.28	Peak	V	100	151	-40.32	-20	20.32
1672.00	46.59	Peak	V	120	78	-47.61	-20	27.61
...	...		V					

Modulation		4FSK		Channel Separation		12.5KHz		
Test Channel		Middle Channel		Test Frequency		435.5000 MHz		
Frequency (MHz)	E-Field Level (dBuv/m)	EMI Detector (Peak/QP)	Antenna Polarization	Antenna Height (cm)	Table Angle (Degree)	ERP measured by Substitution Method (dBm)	Limit (dBm)	Margin (dB)
871.00	54.12	Peak	H	200	53	-41.08	-20	21.08
1306.50	56.73	Peak	H	200	139	-36.47	-20	16.47
1742.00	45.87	Peak	H	150	320	-49.23	-20	29.23
...	...		H					
871.00	55.23	Peak	V	150	147	-39.97	-20	19.97
1306.50	52.74	Peak	V	120	225	-41.86	-20	21.86
1742.00	47.23	Peak	V	120	347	-46.97	-20	26.97
...	...		V					

Modulation		4FSK		Channel Separation		12.5KHz		
Test Channel		High Channel		Test Frequency		453.0000 MHz		
Frequency (MHz)	E-Field Level (dBuv/m)	EMI Detector (Peak/QP)	Antenna Polarization	Antenna Height (cm)	Table Angle (Degree)	ERP measured by Substitution Method (dBm)	Limit (dBm)	Margin (dB)
906.00	53.75	Peak	H	250	58	-41.45	-20	21.45
1359.00	57.04	Peak	H	230	186	-36.16	-20	16.16
1812.00	46.60	Peak	H	110	295	-48.50	-20	28.50
...	...		H					
906.00	54.86	Peak	V	140	128	-40.34	-20	20.34
1359.00	52.44	Peak	V	120	54	-42.16	-20	22.16
1812.00	46.12	Peak	V	120	263	-48.08	-20	28.08
...	...		V					

Modulation		4FSK		Channel Separation		12.5KHz		
Test Channel		High Channel		Test Frequency		469.5000 MHz		
Frequency (MHz)	E-Field Level (dBuv/m)	EMI Detector (Peak/QP)	Antenna Polarization	Antenna Height (cm)	Table Angle (Degree)	ERP measured by Substitution Method (dBm)	Limit (dBm)	Margin (dB)
939.00	56.25	Peak	H	120	74	-38.95	-20	18.95
1408.50	54.46	Peak	H	150	163	-38.74	-20	18.74
1878.00	48.56	Peak	H	200	140	-46.54	-20	26.54
...	...		H					
939.00	54.67	Peak	V	100	130	-40.53	-20	20.53
1408.50	54.02	Peak	V	150	241	-40.58	-20	20.58
1878.00	45.72	Peak	V	120	350	-48.48	-20	28.48
...	...		V					

4.4. Spurious Emission on Antenna Port

TEST APPLICABLE

The same as Section 4.3

TEST PROCEDURE

The RF output of the EUT was connected to a spectrum analyzer through appropriate attenuation. The resolution bandwidth of the spectrum analyzer was set to 100 kHz. Sufficient scans were taken to show any out of band emission up to 10th. Harmonic for the lower and the highest frequency range. Set RBW 100 kHz, VBW 300 kHz in the frequency band 30MHz to 1GHz, while set RBW=1MHz, VBW=3MHz from the 1GHz to 10th Harmonic.

The audio input was set to 0 to get the unmodulated carrier, the resulting picture is print out for each channel separation.

TEST CONFIGURATION

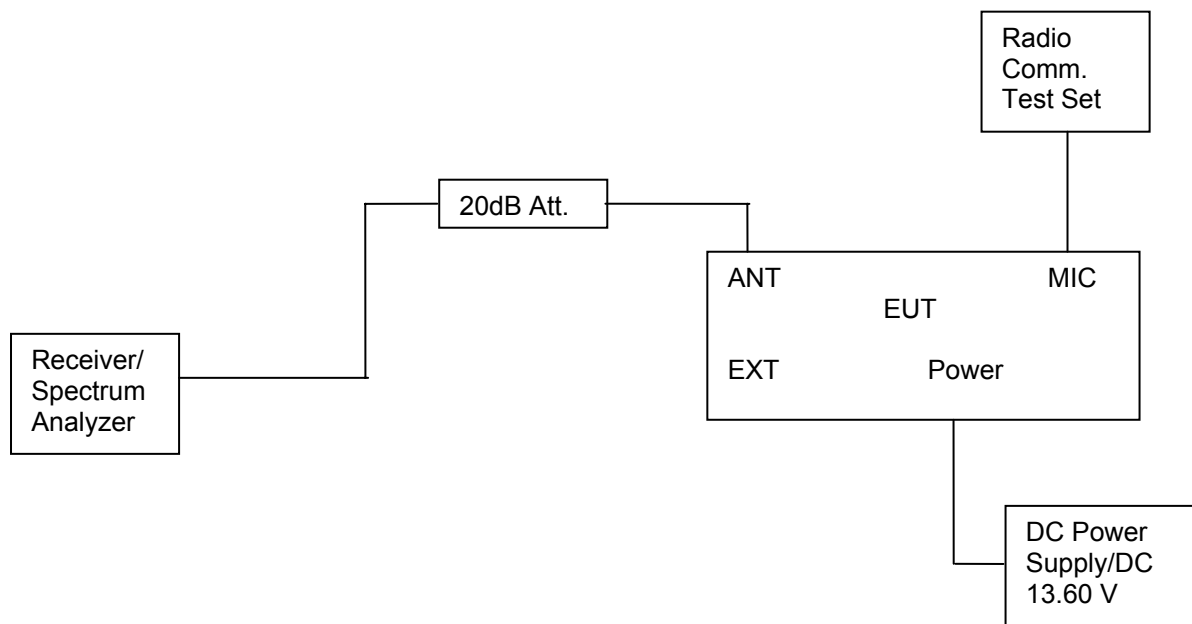

TEST RESULTS

Modulation Type: FM

FCC Part 22.359, 74.462, 80.211 and 90.210 and RSS Gen, RSS 119 Issue 11 (12.5 kHz bandwidth only): On any frequency removed from the center of the authorized bandwidth by a displacement frequency (f d in kHz) of more than 12.5 kHz at least:

Low: $50 + 10 \log (P_{\text{watts}}) = 50 + 10 \log (10.16) = 60.07 \text{ dB}$

High: $50 + 10 \log (P_{\text{watts}}) = 50 + 10 \log (10.72) = 60.30 \text{ dB}$

Note: In general, the worse case attenuation requirement shown above was applied.

Calculation: Limit (dBm) = EL - 50 - 10log₁₀ (TP)

Notes: EL is the emission level of the Output Power expressed in dBm,
In this application, the EL is 40.30 dBm.

Limit (dBm) = 40.30 - 50 - 10log₁₀ (10.72) = -20 dBm

Modulation Type: 4FSK

FCC Part 22.359, 74.462, 80.211 and 90.210 and RSS Gen, RSS 119 Issue 11 (12.5 kHz Bandwidth only): On any frequency removed from the center of the authorized bandwidth by a displacement frequency (f d in kHz) of more than 12.5 kHz at least:

Low: $50 + 10 \log (P_{\text{watts}}) = 50 + 10 \log (10.57) = 60.24 \text{ dB}$

High: $50 + 10 \log (P_{\text{watts}}) = 50 + 10 \log (10.99) = 60.41 \text{ dB}$

Note: In general, the worse case attenuation requirement shown above was applied.

Calculation: Limit (dBm) = EL - 50 - 10log₁₀ (TP)

Notes: EL is the emission level of the Output Power expressed in dBm,
In this application, the EL is 40.41 dBm.

Limit (dBm) = 40.41 - 50 - 10log₁₀ (10.99) = -20 dBm

- Note: 1. In general, the worse case attenuation requirement shown above was applied.
2. The measurement frequency range from 30 MHz to 4 GHz.

For Rated High Power (10Watt)

Modulation Type	Channel Separation	Test Channel	Test Frequency (MHz)	Maximum Conducted Spurious Emissions Below 1GHz		Maximum Conducted Spurious Emissions Above 1GHz	
				Frequency (MHz)	Datum (dBm)	Frequency (MHz)	Datum (dBm)
FM	12.5KHz	Low	406.5000	778.00	-38.18	3152.00	-35.38
		Low	418.0000	577.00	-39.25	3248.00	-36.21
		Middle	435.5000	436.08	-40.00	3208.00	-35.53
		High	453.0000	526.00	-38.83	3136.00	-35.73
		High	469.5000	541.00	-38.25	3264.00	-35.49
4FSK	12.5KHz	Low	406.5000	759.00	-39.01	3144.00	-34.74
		Low	418.0000	734.00	-38.30	3168.00	-35.53
		Middle	435.5000	436.08	-40.20	3256.00	-35.76
		High	453.0000	729.00	-39.09	3184.00	-35.16
		High	469.5000	949.00	-38.89	3248.00	-34.55
Limit		-20dBm for 12.5KHz Channel Separation					
Test Results		Compliance					

For Rated Low Power (1Watt)

Modulation Type	Channel Separation	Test Channel	Test Frequency (MHz)	Maximum Conducted Spurious Emissions Below 1GHz		Maximum Conducted Spurious Emissions Above 1GHz	
				Frequency (MHz)	Datum (dBm)	Frequency (MHz)	Datum (dBm)
FM	12.5KHz	Low	406.5000	813.76	-28.46	3616.00	-35.97
		Low	418.0000	837.04	-26.88	3120.00	-35.86
		Middle	435.5000	95.96	-77.67	3120.00	-35.13
		High	453.0000	906.88	-27.40	3200.00	-35.98
		High	469.5000	939.86	-26.68	3224.00	-34.17
4FSK	12.5KHz	Low	406.5000	813.76	-27.89	3272.00	-35.19
		Low	418.0000	837.04	-26.90	3224.00	-34.76
		Middle	435.5000	871.96	-26.95	3264.00	-36.17
		High	453.0000	904.94	-28.43	3136.00	-35.13
		High	469.5000	939.86	-25.40	3176.00	-36.05
Limit		-20dBm for 12.5KHz Channel Separation					
Test Results		Compliance					

Plots of Spurious Emission on Antenna Port Measurement**For Rated High Power (10Watt)**

Modulation Type	Channel Sparation	Test Channel	Test Frequency (MHz)	Maximum Conducted Spurious Emissions Below 1GHz		Maximum Conducted Spurious Emissions Above 1GHz		FCC Limit
				Frequency (MHz)	Datum (dBm)	Frequency (MHz)	Datum (dBm)	
FM	12.5KHz	Low	406.5000	778.00	-38.18	3152.00	-35.38	-20dBm
Test Results				Compliance				

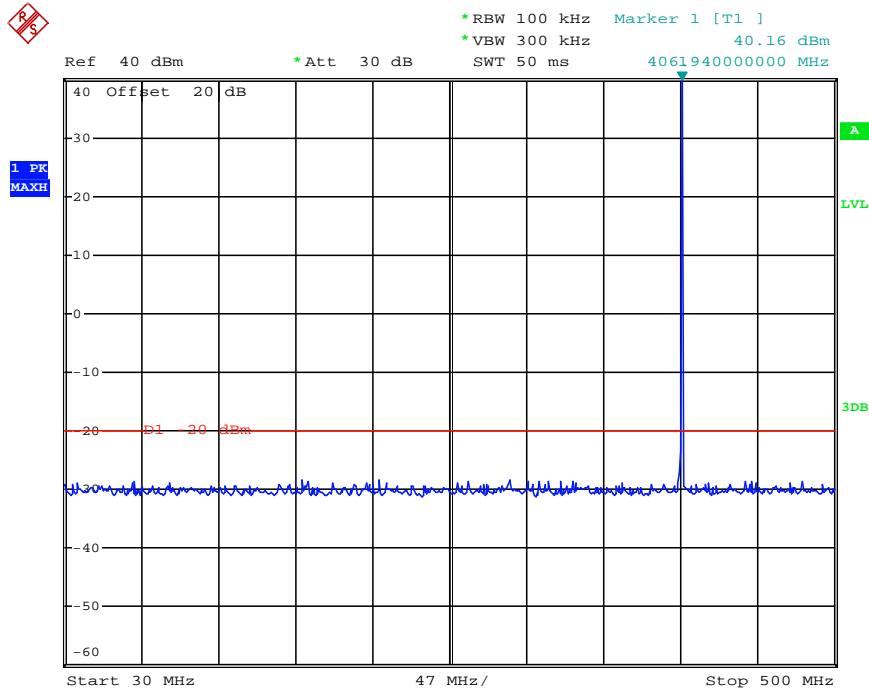

Date: 21.JAN.2013 14:37:46

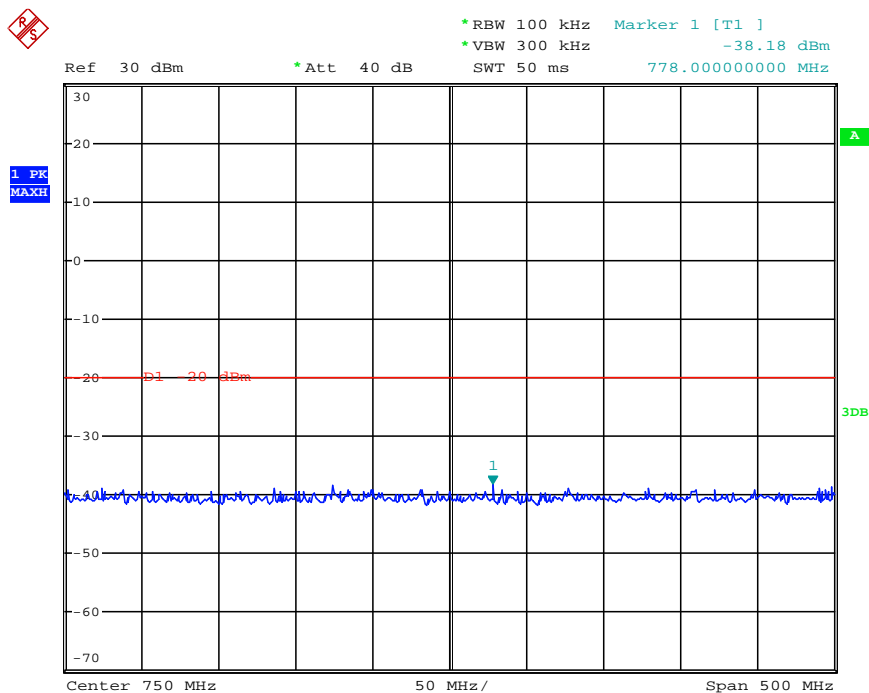

Date: 21.JAN.2013 14:46:06

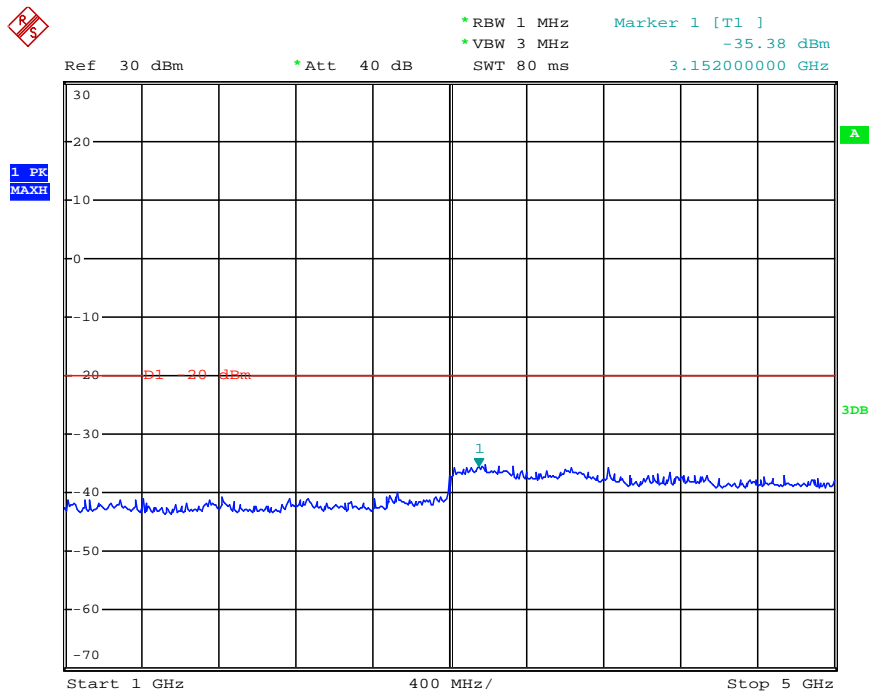

Date: 21.JAN.2013 14:48:15

Modulation Type	Channel SpARATION	Test Channel	Test Frequency (MHz)	Maximum Conducted Spurious Emissions Below 1GHz		Maximum Conducted Spurious Emissions Above 1GHz		FCC Limit
				Frequency (MHz)	Datum (dBm)	Frequency (MHz)	Datum (dBm)	
FM	12.5KHz	Low	418.0000	577.00	-39.25	3248.00	-36.21	-20dBm
Test Results				Compliance				

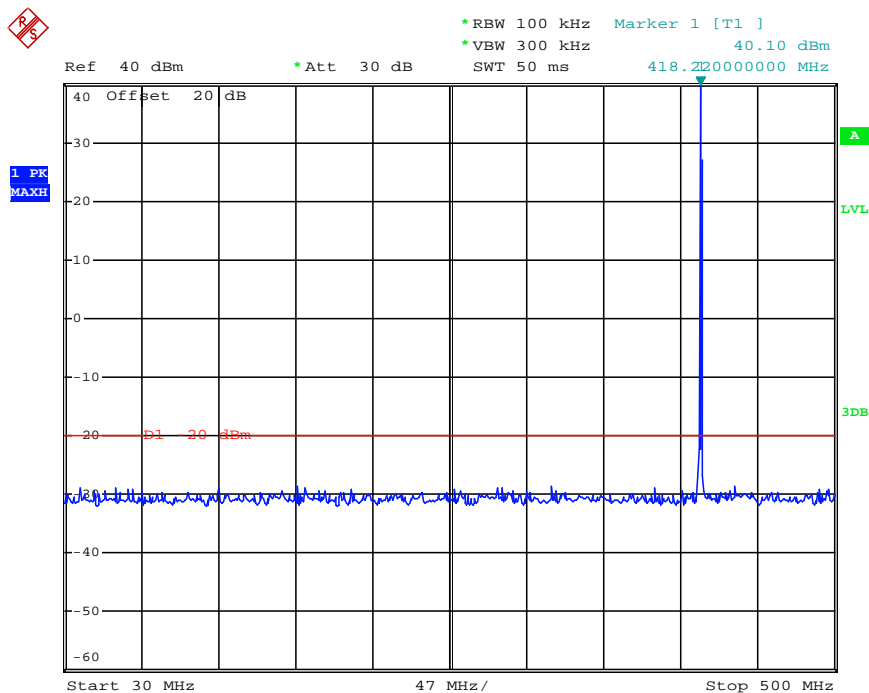

Date: 21.JAN.2013 14:38:06

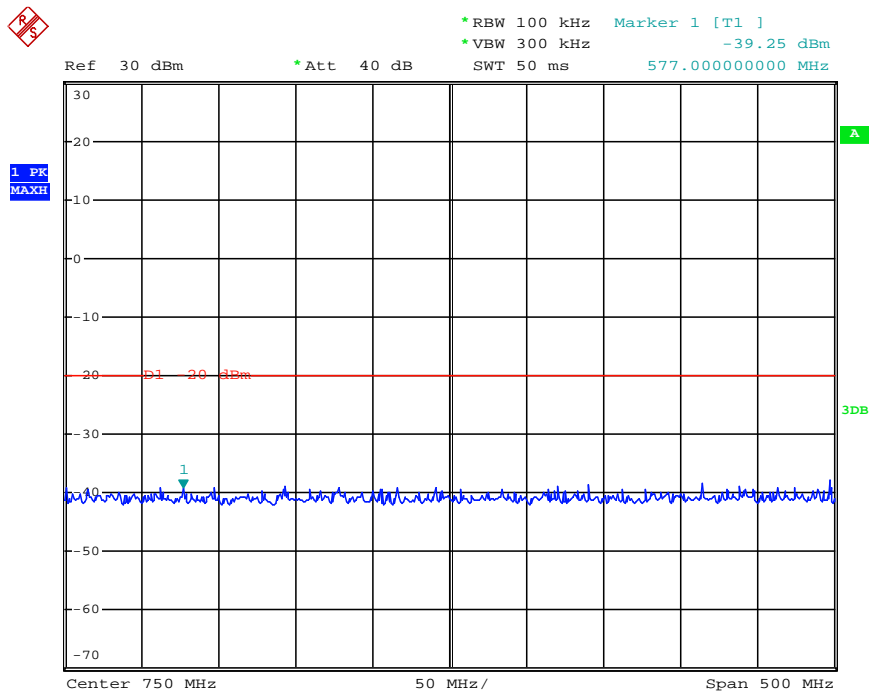

Date: 21.JAN.2013 14:46:29

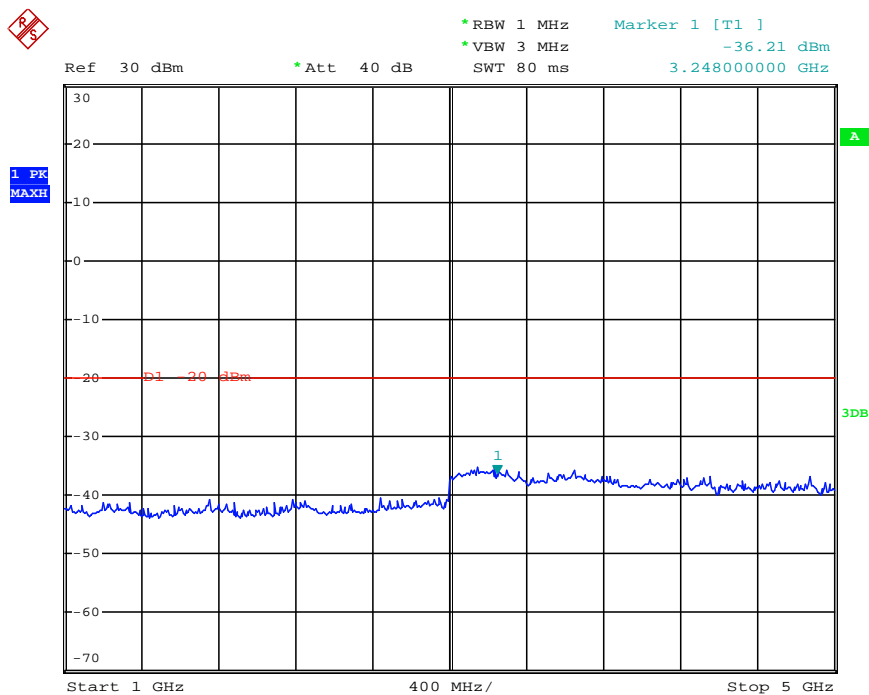

Date: 21.JAN.2013 14:48:39

Modulation Type	Channel SpARATION	Test Channel	Test Frequency (MHz)	Maximum Conducted Spurious Emissions Below 1GHz		Maximum Conducted Spurious Emissions Above 1GHz		FCC Limit
				Frequency (MHz)	Datum (dBm)	Frequency (MHz)	Datum (dBm)	
FM	12.5KHz	Middle	435.5000	436.08	-40.00	3208.00	-35.53	-20dBm
Test Results				Compliance				

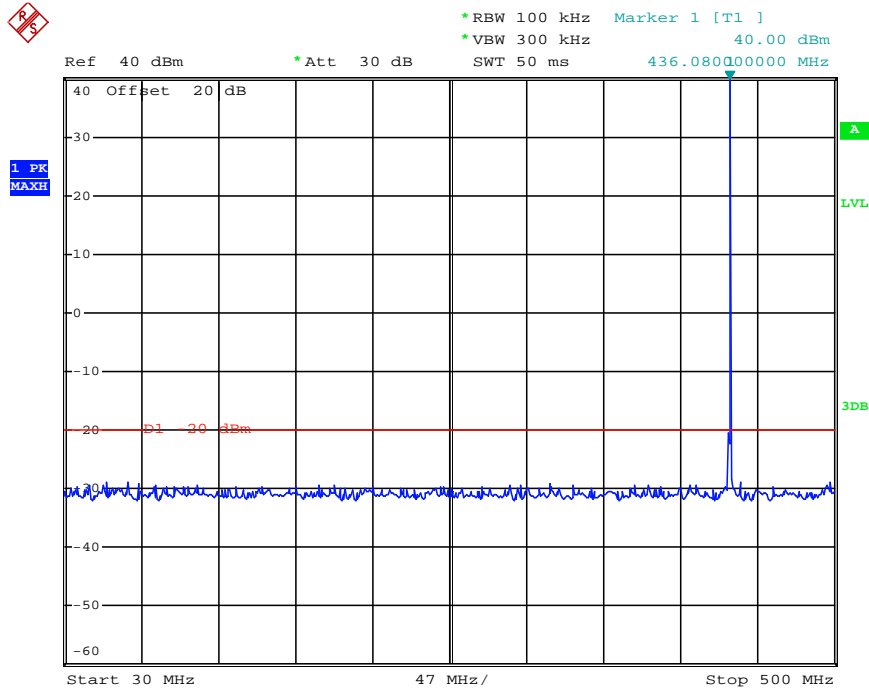

Date: 21.JAN.2013 14:38:24

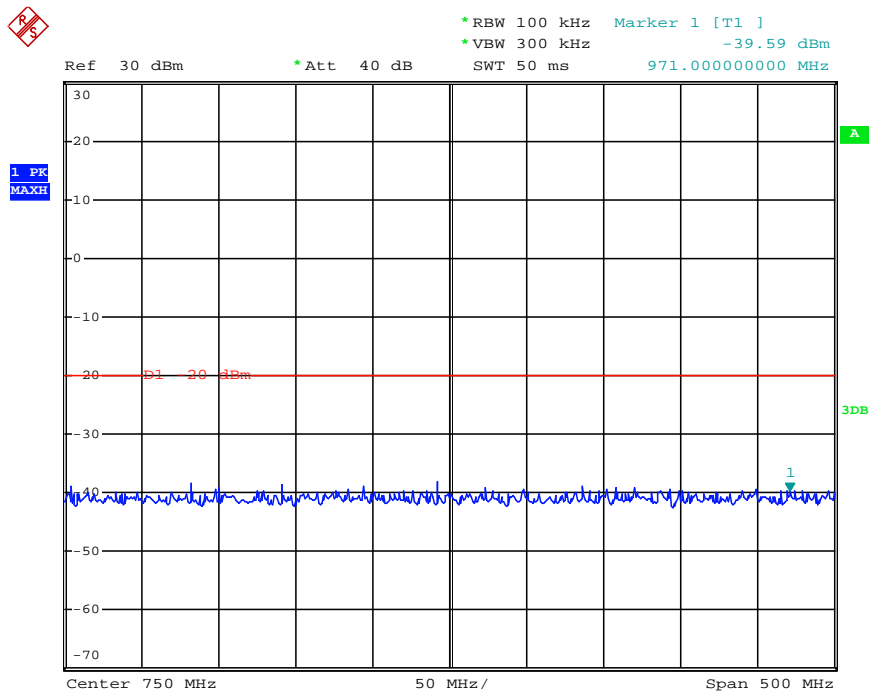

Date: 21.JAN.2013 14:46:44

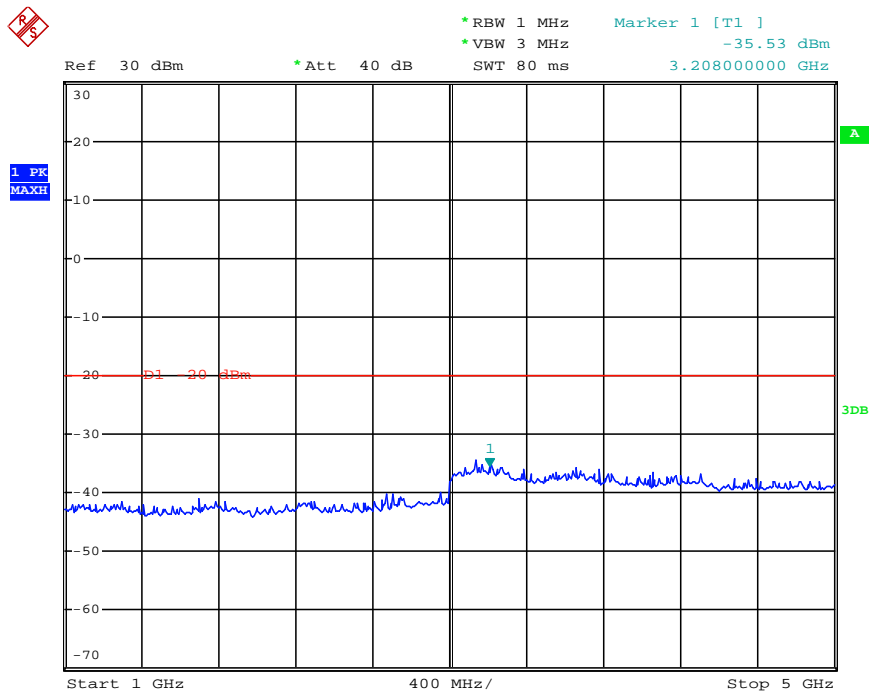

Date: 21.JAN.2013 14:48:57

Modulation Type	Channel SpARATION	Test Channel	Test Frequency (MHz)	Maximum Conducted Spurious Emissions Below 1GHz		Maximum Conducted Spurious Emissions Above 1GHz		FCC Limit
				Frequency (MHz)	Datum (dBm)	Frequency (MHz)	Datum (dBm)	
FM	12.5KHz	High	453.0000	526.00	-38.83	3136.00	-35.73	-20dBm
Test Results				Compliance				

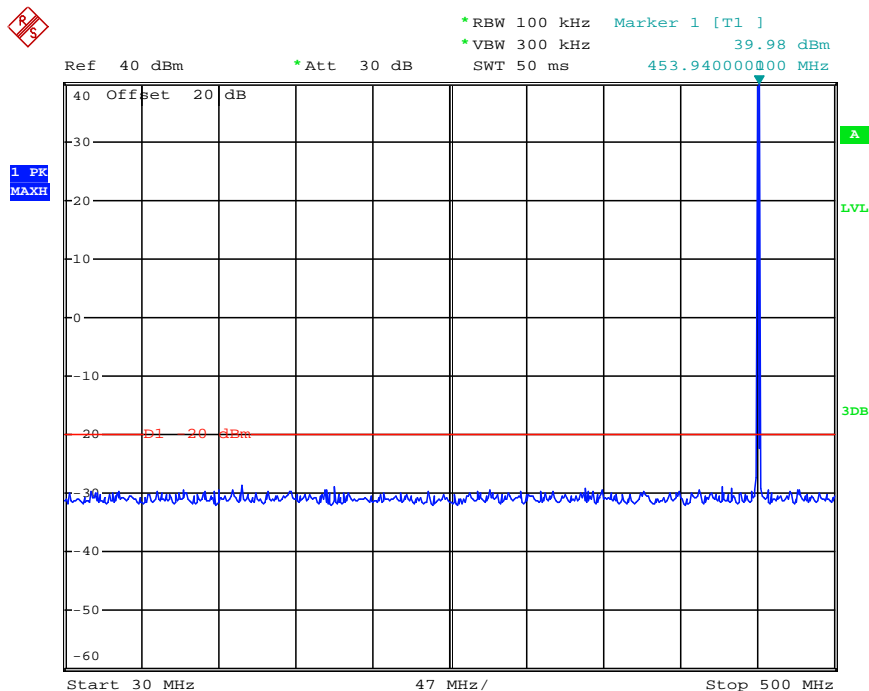

Date: 21.JAN.2013 14:38:47

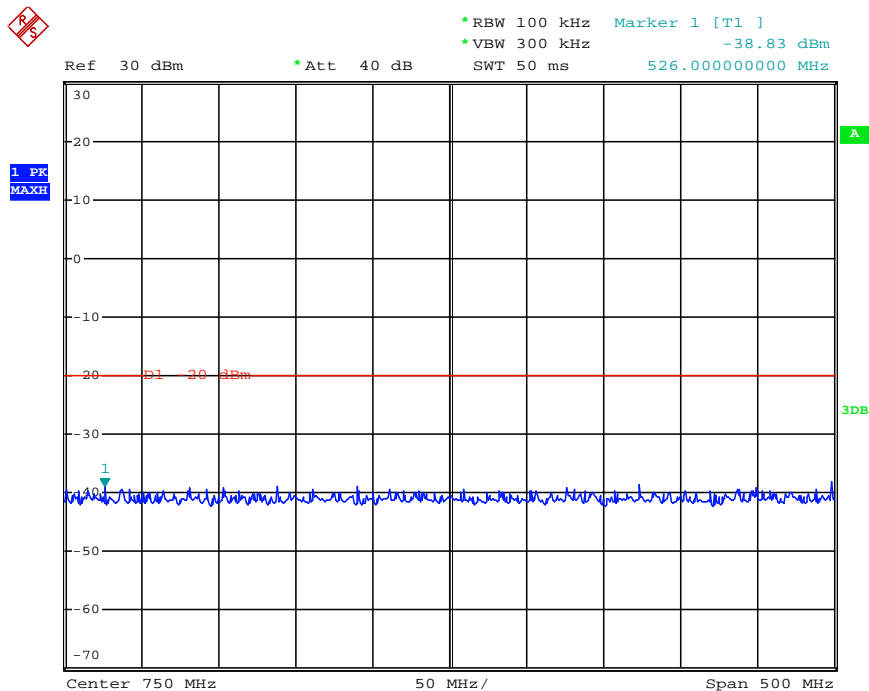

Date: 21.JAN.2013 14:47:01

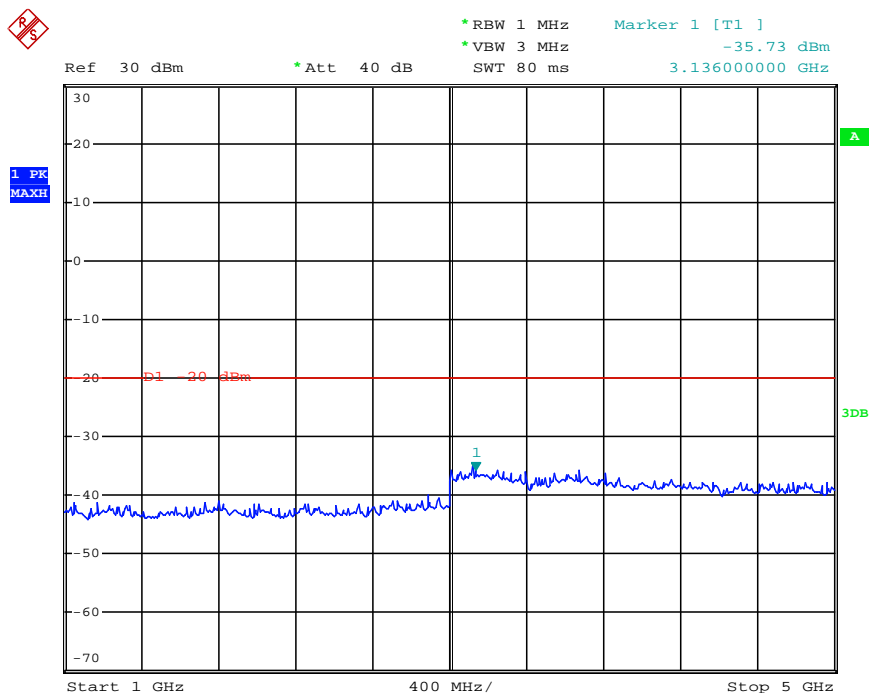

Date: 21.JAN.2013 14:49:11

Modulation Type	Channel SpARATION	Test Channel	Test Frequency (MHz)	Maximum Conducted Spurious Emissions Below 1GHz		Maximum Conducted Spurious Emissions Above 1GHz		FCC Limit
				Frequency (MHz)	Datum (dBm)	Frequency (MHz)	Datum (dBm)	
FM	12.5KHz	High	469.5000	541.00	-38.25	3264.00	-35.49	-20dBm
Test Results				Compliance				

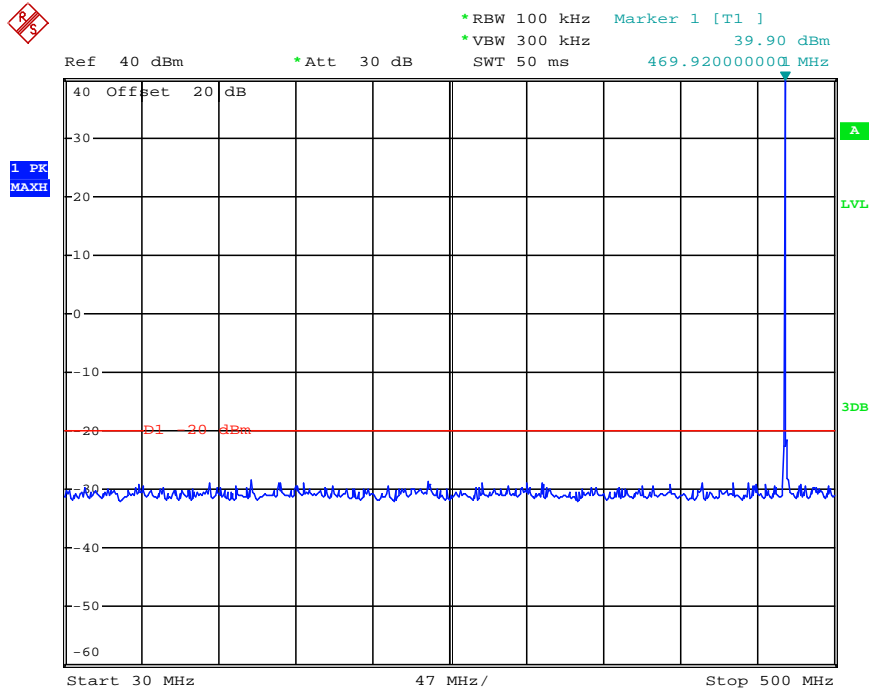

Date: 21.JAN.2013 14:39:05

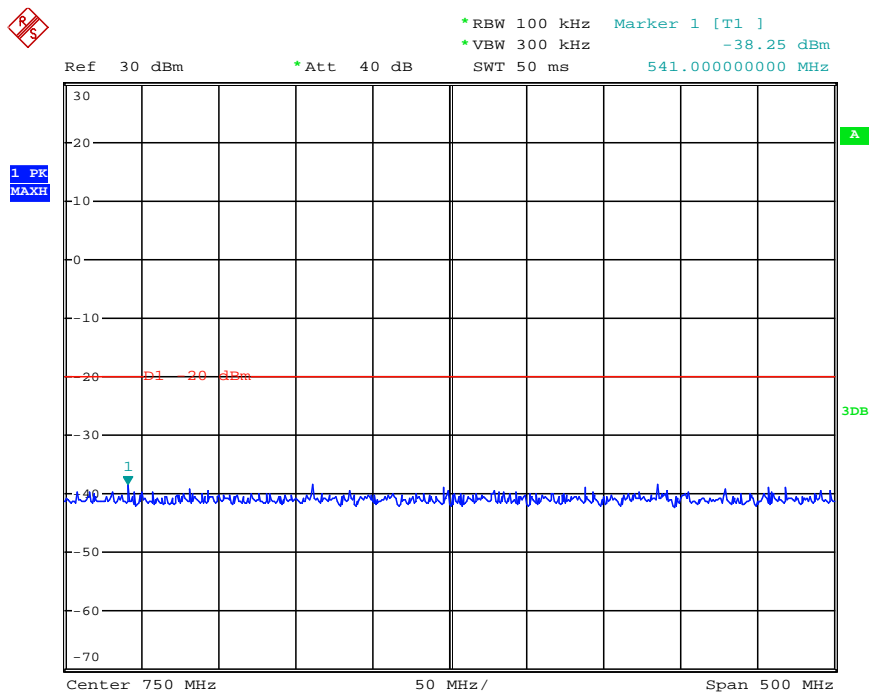

Date: 21.JAN.2013 14:47:18

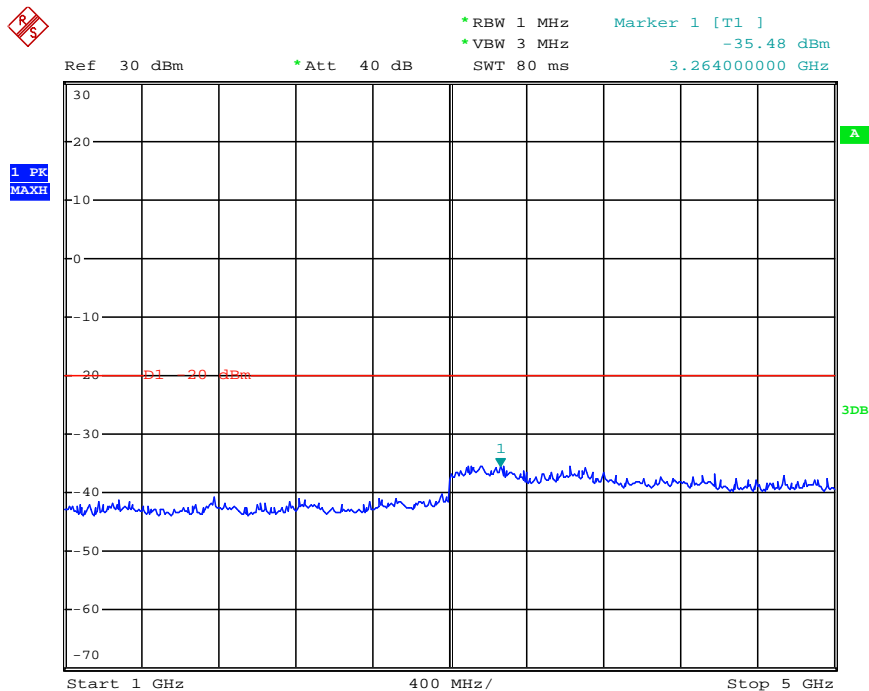

Date: 21.JAN.2013 14:49:27

Modulation Type	Channel Spation	Test Channel	Test Frequency (MHz)	Maximum Conducted Spurious Emissions Below 1GHz		Maximum Conducted Spurious Emissions Above 1GHz		FCC Limit
				Frequency (MHz)	Datum (dBm)	Frequency (MHz)	Datum (dBm)	
4FSK	12.5KHz	Low	406.5000	759.00	-39.01	3144.00	-34.74	-20dBm
Test Results				Compliance				

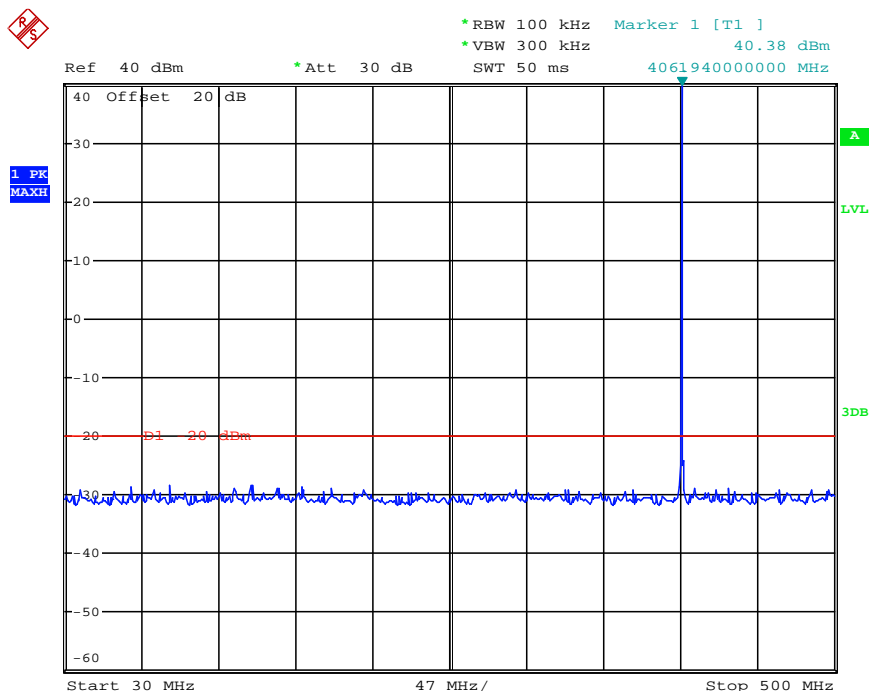

Date: 23.JAN.2013 15:03:56

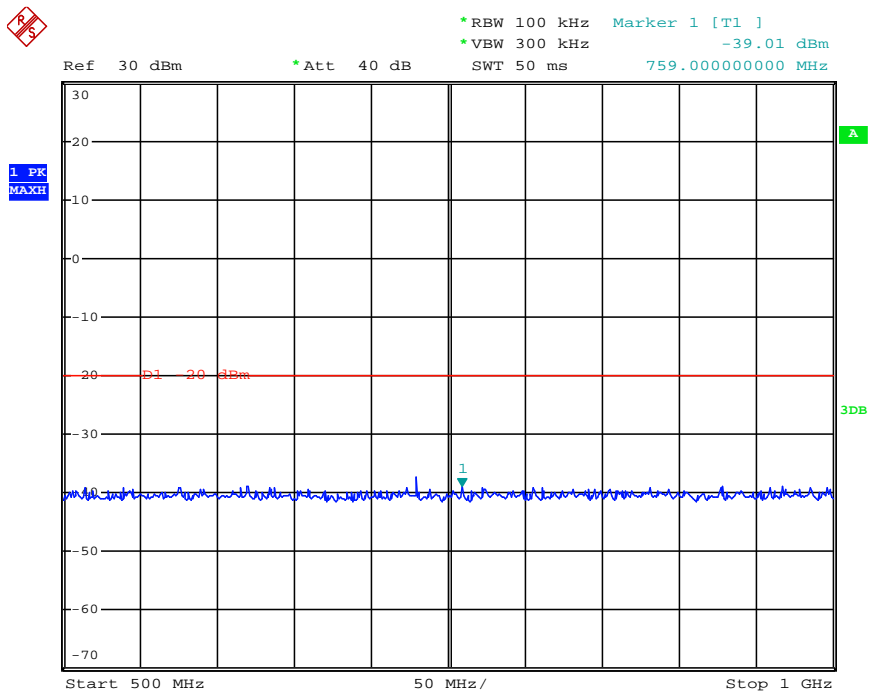

Date: 23.JAN.2013 15:08:44

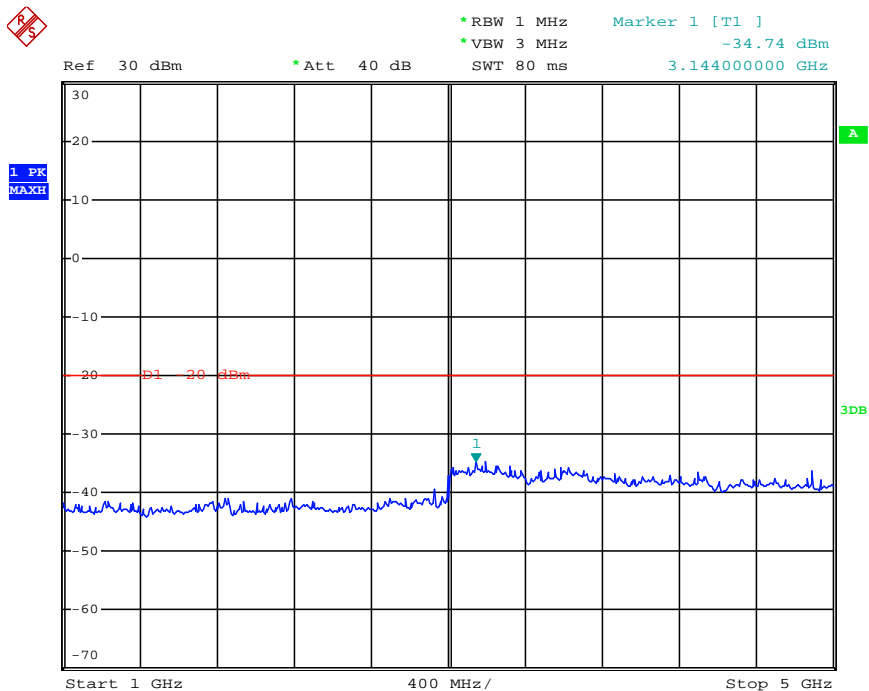

Date: 21.JAN.2013 14:57:11

Modulation Type	Channel Separation	Test Channel	Test Frequency (MHz)	Maximum Conducted Spurious Emissions Below 1GHz		Maximum Conducted Spurious Emissions Above 1GHz		FCC Limit
				Frequency (MHz)	Datum (dBm)	Frequency (MHz)	Datum (dBm)	
4FSK	12.5KHz	Low	418.0000	734.00	-38.30	3168.00	-35.53	-20dBm
Test Results				Compliance				

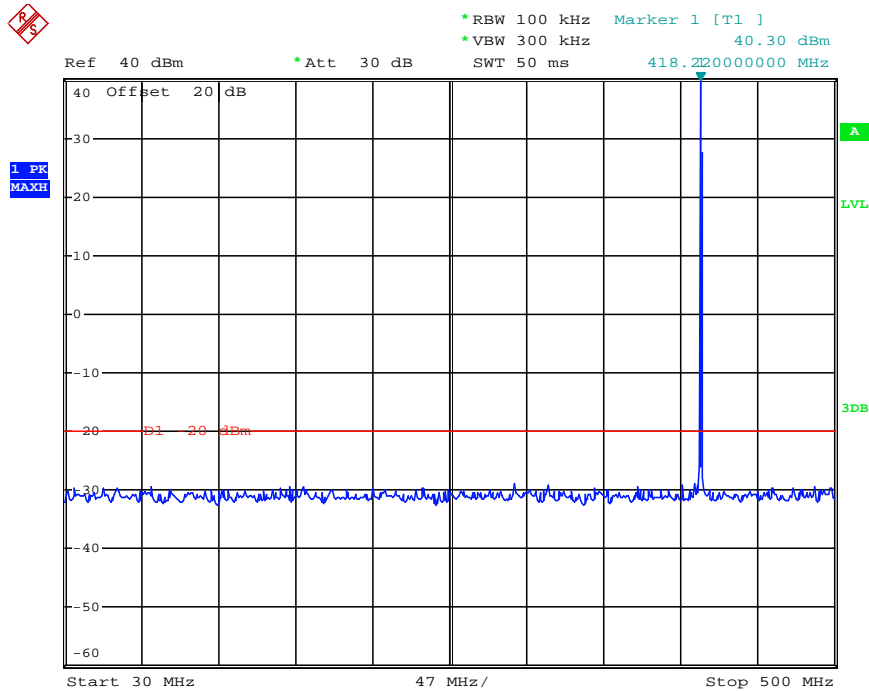

Date: 23.JAN.2013 15:04:09

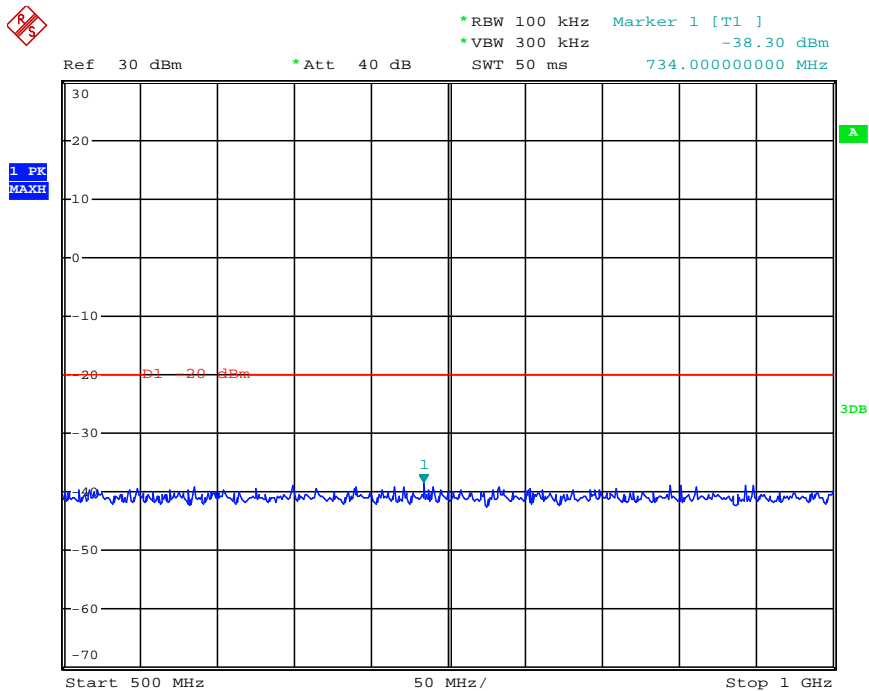

Date: 23.JAN.2013 15:09:00

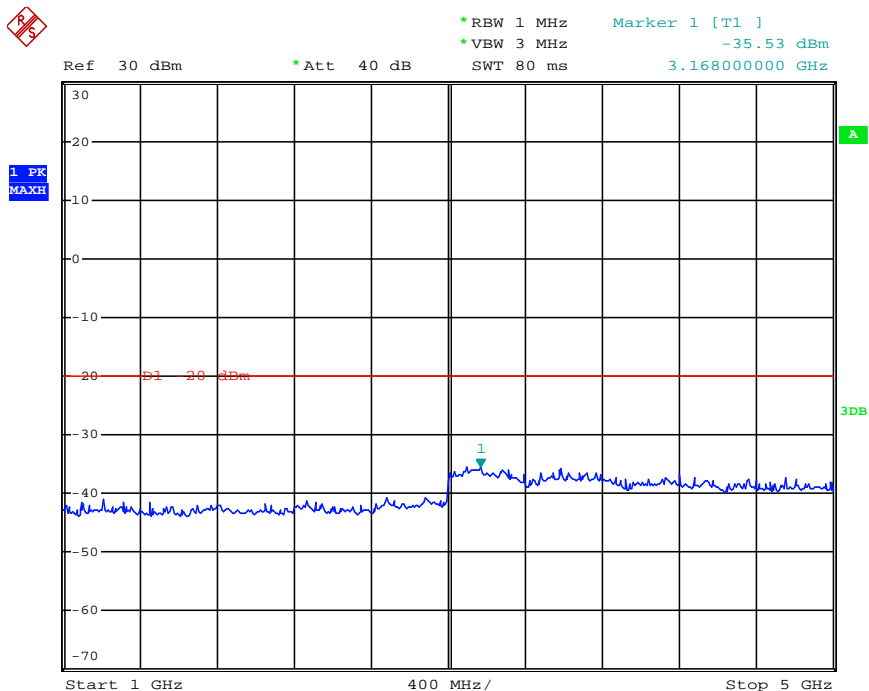

Date: 21.JAN.2013 14:57:29

Modulation Type	Channel SpARATION	Test Channel	Test Frequency (MHz)	Maximum Conducted Spurious Emissions Below 1GHz		Maximum Conducted Spurious Emissions Above 1GHz		FCC Limit
				Frequency (MHz)	Datum (dBm)	Frequency (MHz)	Datum (dBm)	
4FSK	12.5KHz	Middle	435.5000	436.08	-40.20	3256.00	-35.76	-20dBm
Test Results				Compliance				

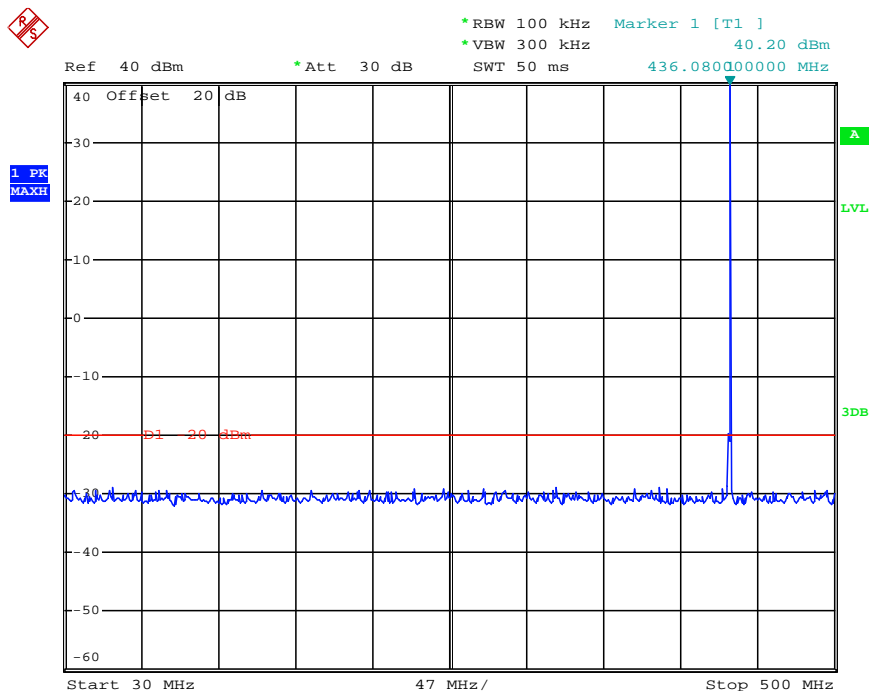

Date: 23.JAN.2013 15:04:30

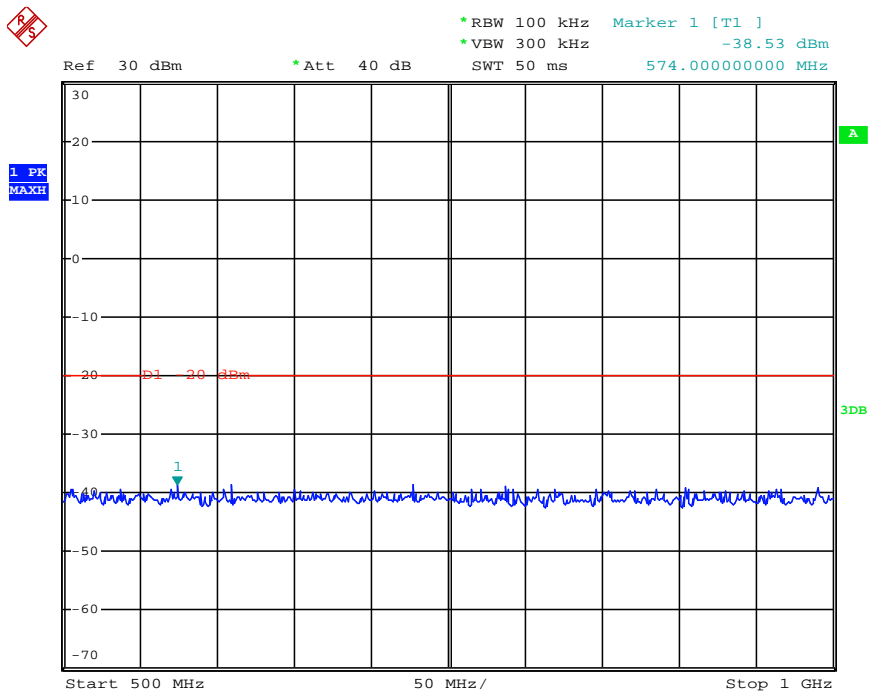

Date: 23.JAN.2013 15:09:15

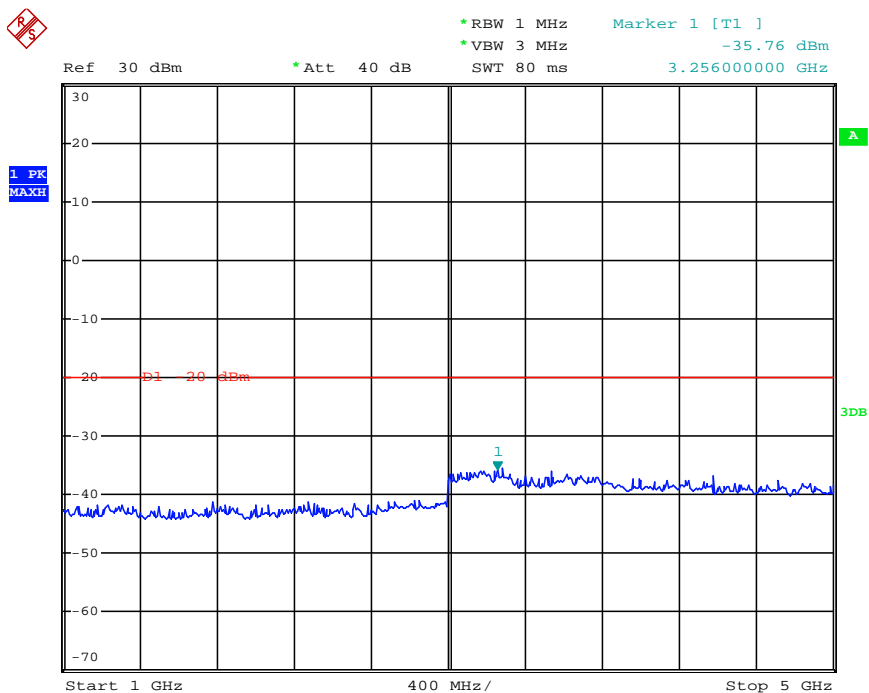

Date: 21.JAN.2013 14:57:40

Modulation Type	Channel Sparation	Test Channel	Test Frequency (MHz)	Maximum Conducted Spurious Emissions Below 1GHz		Maximum Conducted Spurious Emissions Above 1GHz		FCC Limit
				Frequency (MHz)	Datum (dBm)	Frequency (MHz)	Datum (dBm)	
4FSK	12.5KHz	High	453.0000	729.00	-39.09	3184.00	-35.16	-20dBm
Test Results				Compliance				

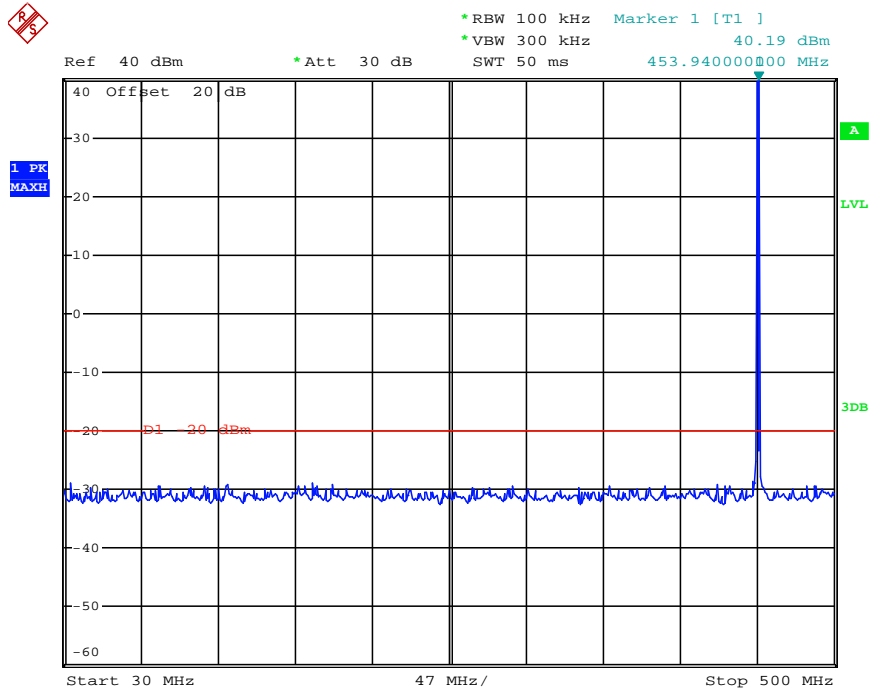

Date: 23.JAN.2013 15:04:43

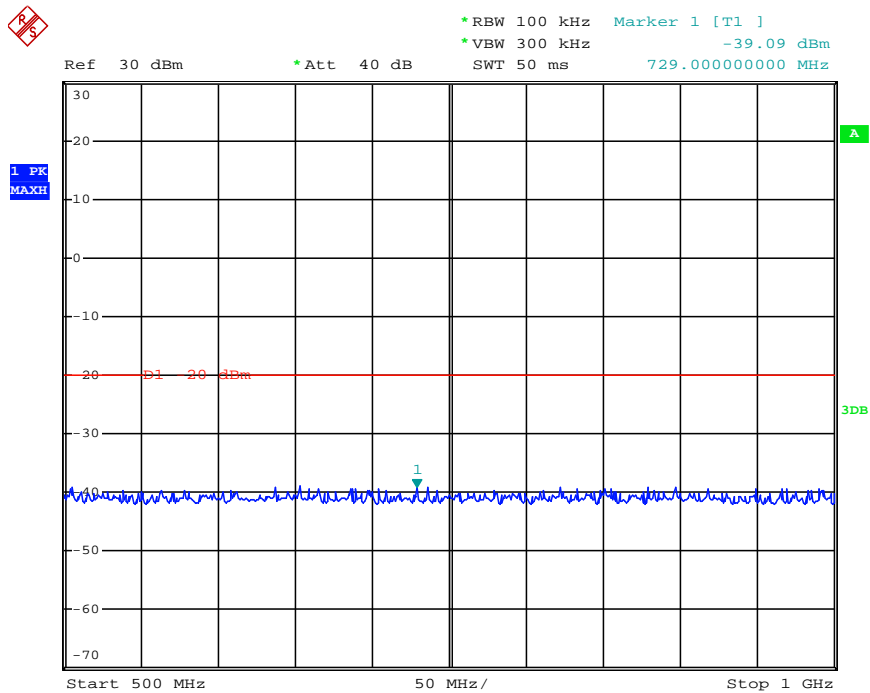

Date: 23.JAN.2013 15:09:28

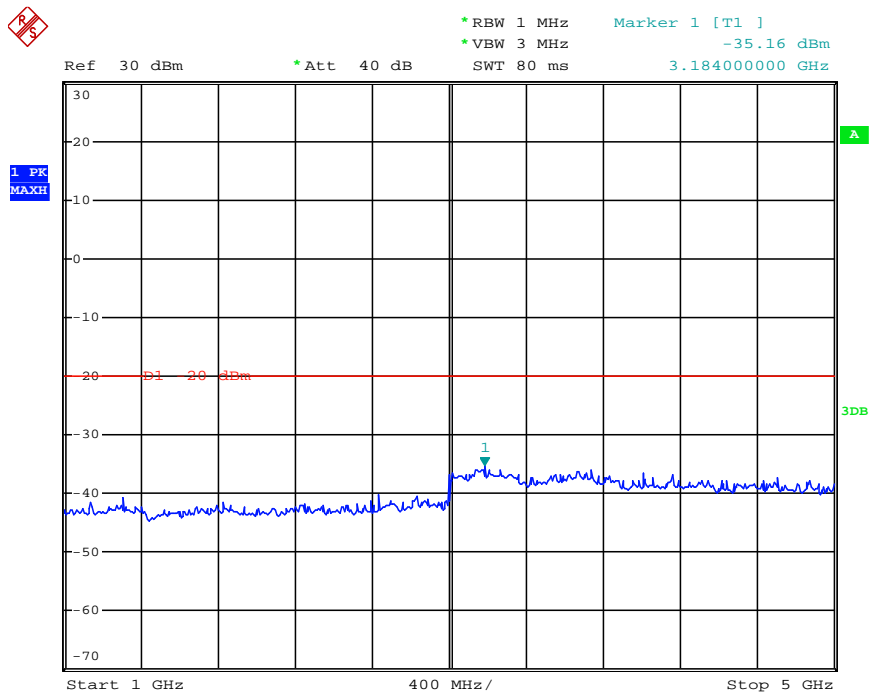

Date: 21.JAN.2013 14:57:51

Modulation Type	Channel Spation	Test Channel	Test Frequency (MHz)	Maximum Conducted Spurious Emissions Below 1GHz		Maximum Conducted Spurious Emissions Above 1GHz		FCC Limit
				Frequency (MHz)	Datum (dBm)	Frequency (MHz)	Datum (dBm)	
4FSK	12.5KHz	High	469.5000	949.00	-38.89	3248.00	-34.55	-20dBm
Test Results				Compliance				

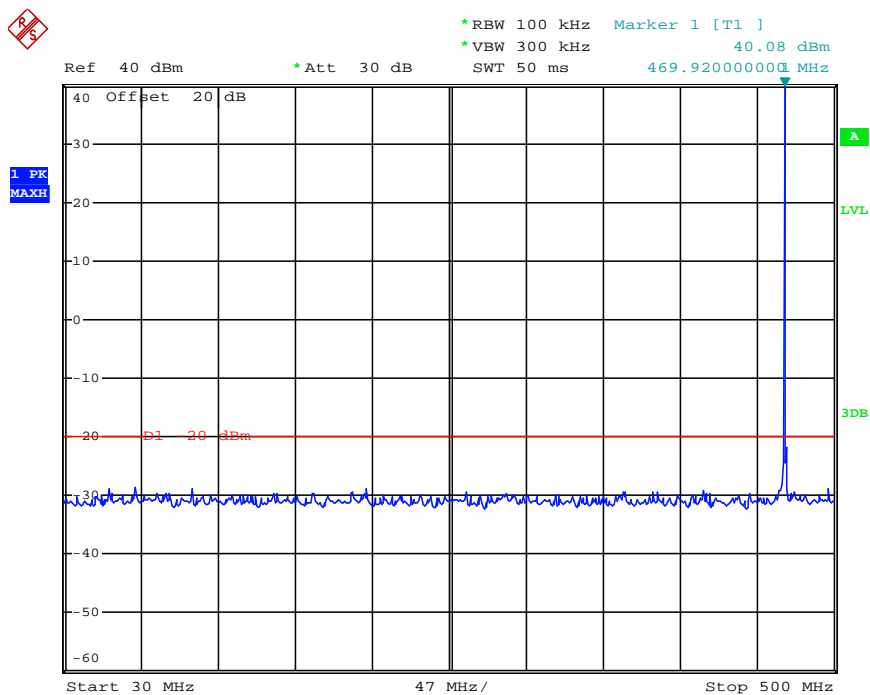

Date: 23.JAN.2013 15:04:58

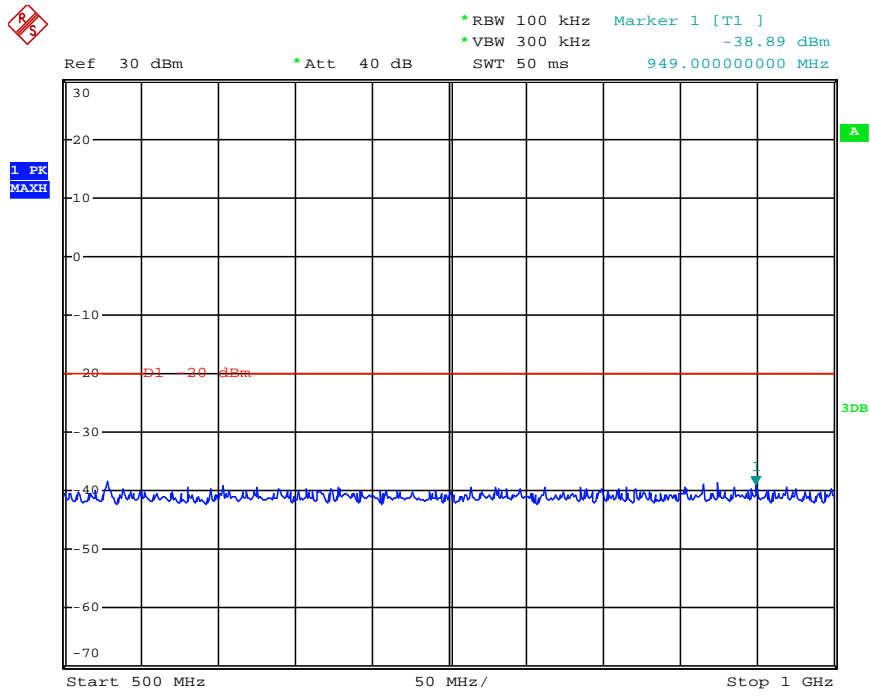

Date: 23.JAN.2013 15:09:39

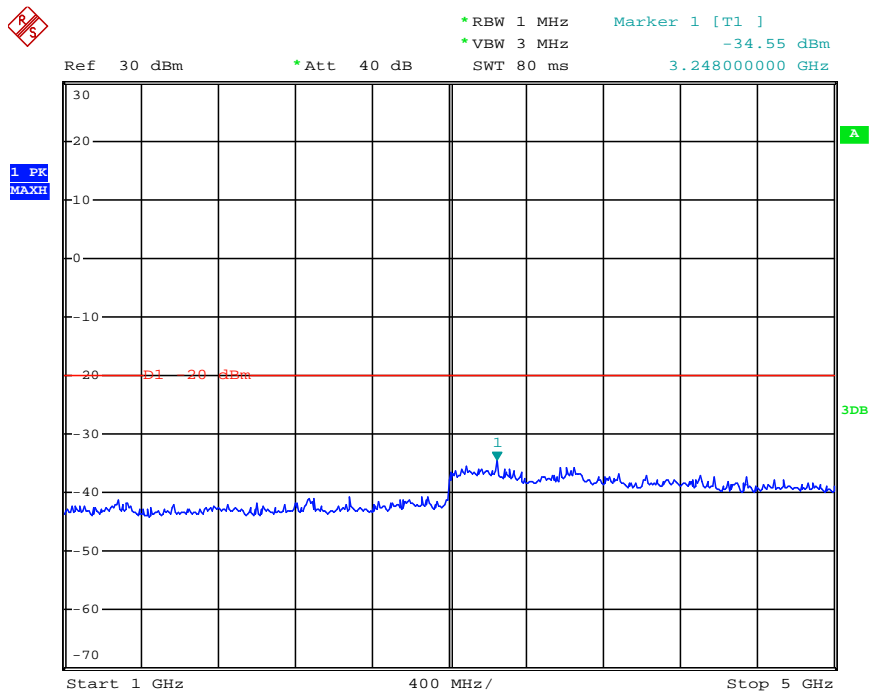

Date: 21.JAN.2013 14:58:06

For Rated Low Power (1Watt)

Modulation Type	Channel Sparation	Test Channel	Test Frequency (MHz)	Maximum Conducted Spurious Emissions Below 1GHz		Maximum Conducted Spurious Emissions Above 1GHz		FCC Limit
				Frequency (MHz)	Datum (dBm)	Frequency (MHz)	Datum (dBm)	
FM	12.5KHz	Low	406.5000	813.76	-28.46	3616.00	-35.97	-20dBm
Test Results				Compliance				

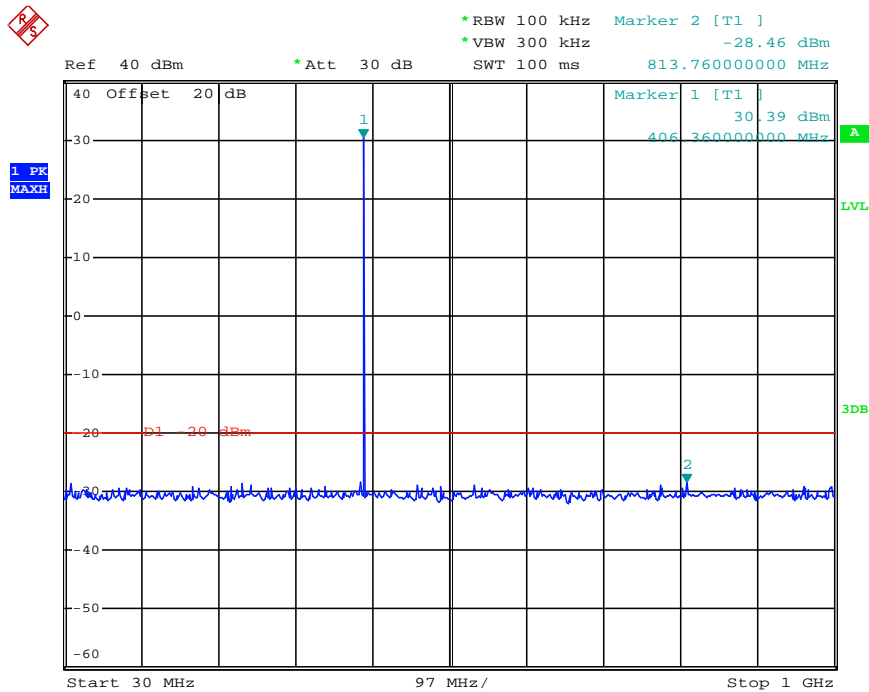

Date: 21.JAN.2013 14:39:42

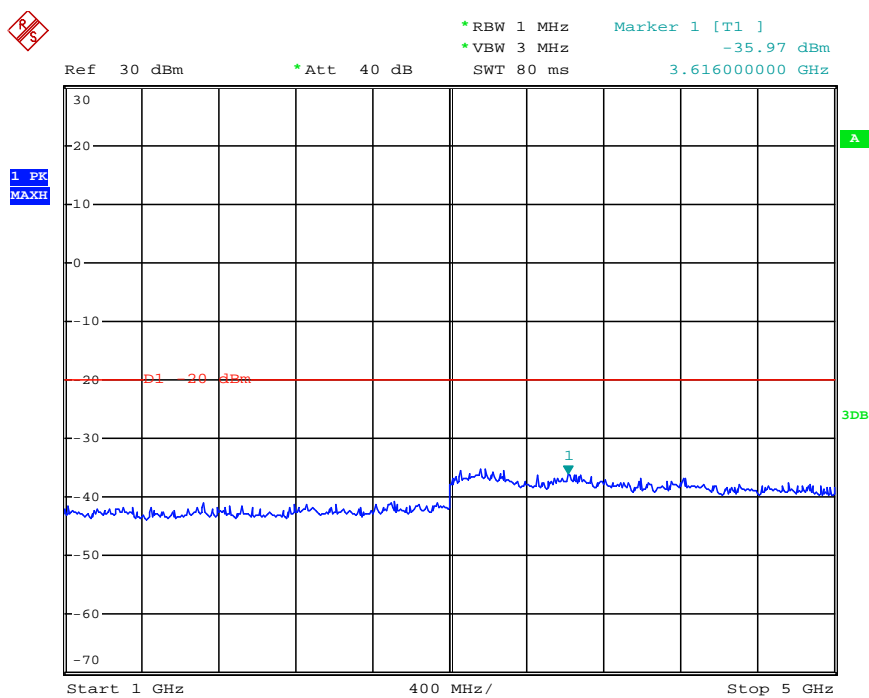

Date: 21.JAN.2013 14:52:39

Modulation Type	Channel SpARATION	Test Channel	Test Frequency (MHz)	Maximum Conducted Spurious Emissions Below 1GHz		Maximum Conducted Spurious Emissions Above 1GHz		FCC Limit
				Frequency (MHz)	Datum (dBm)	Frequency (MHz)	Datum (dBm)	
FM	12.5KHz	Low	418.0000	837.04	-26.88	3120.00	-35.86	-20dBm
Test Results				Compliance				

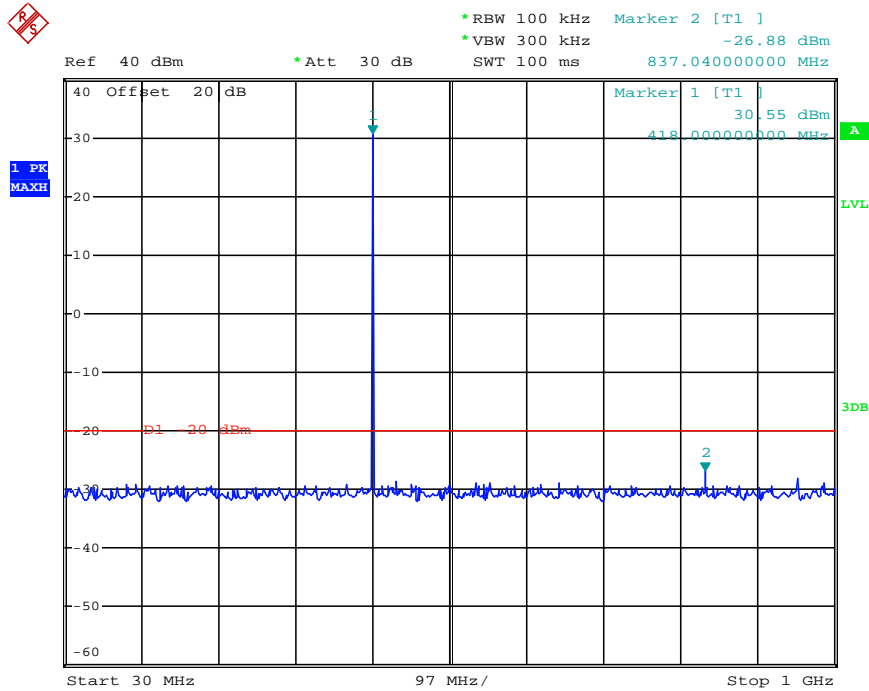

Date: 21.JAN.2013 14:40:06

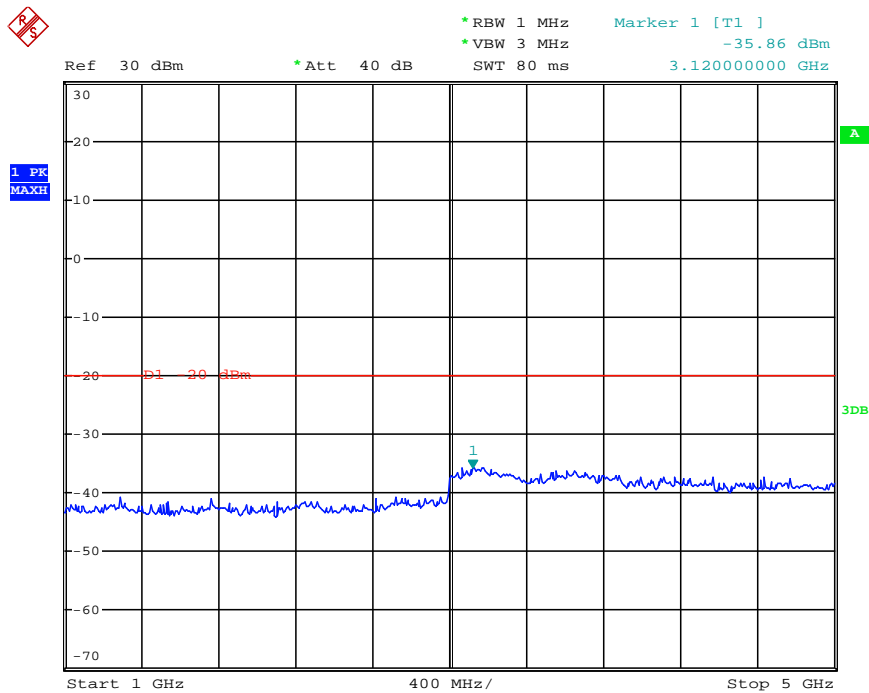

Date: 21.JAN.2013 14:52:57

Modulation Type	Channel Spuration	Test Channel	Test Frequency (MHz)	Maximum Conducted Spurious Emissions Below 1GHz		Maximum Conducted Spurious Emissions Above 1GHz		FCC Limit
				Frequency (MHz)	Datum (dBm)	Frequency (MHz)	Datum (dBm)	
FM	12.5KHz	Middle	435.5000	95.96	-77.67	3120.00	-35.13	-20dBm
Test Results				Compliance				

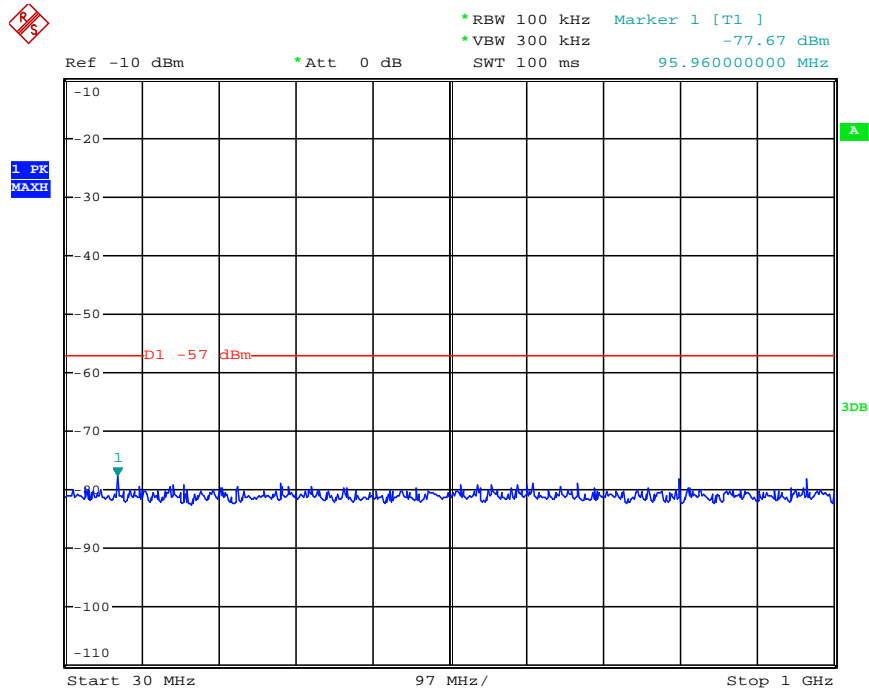

Date: 21.JAN.2013 15:06:19

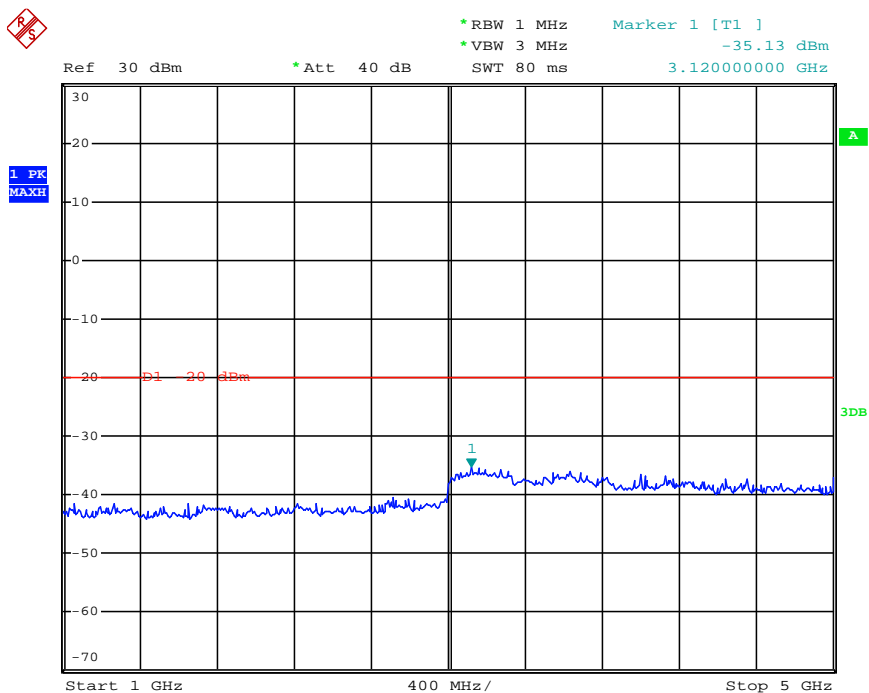

Date: 21.JAN.2013 14:53:16

Modulation Type	Channel SpARATION	Test Channel	Test Frequency (MHz)	Maximum Conducted Spurious Emissions Below 1GHz		Maximum Conducted Spurious Emissions Above 1GHz		FCC Limit
				Frequency (MHz)	Datum (dBm)	Frequency (MHz)	Datum (dBm)	
FM	12.5KHz	High	453.0000	906.88	-27.40	3200.00	-35.98	-20dBm
Test Results				Compliance				

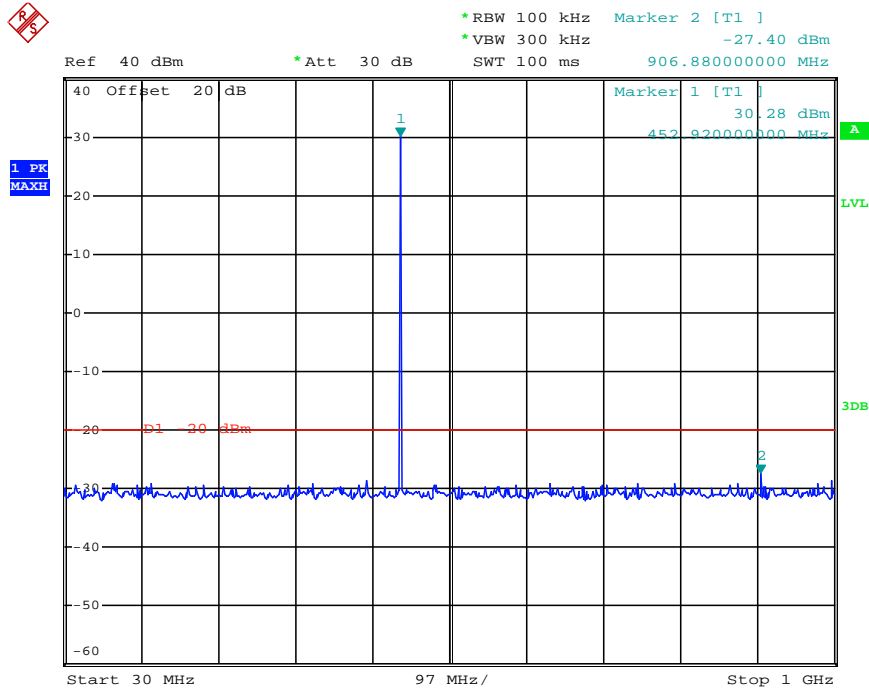

Date: 21.JAN.2013 14:40:51

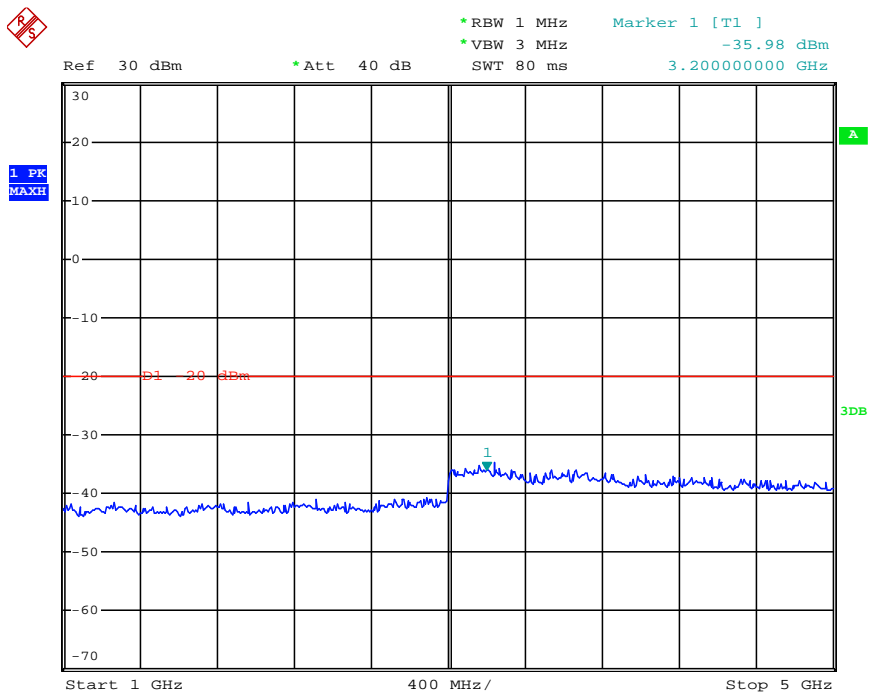

Date: 21.JAN.2013 14:53:38

Modulation Type	Channel SpARATION	Test Channel	Test Frequency (MHz)	Maximum Conducted Spurious Emissions Below 1GHz		Maximum Conducted Spurious Emissions Above 1GHz		FCC Limit
				Frequency (MHz)	Datum (dBm)	Frequency (MHz)	Datum (dBm)	
FM	12.5KHz	High	469.5000	939.86	-26.68	3224.00	-34.17	-20dBm
Test Results				Compliance				

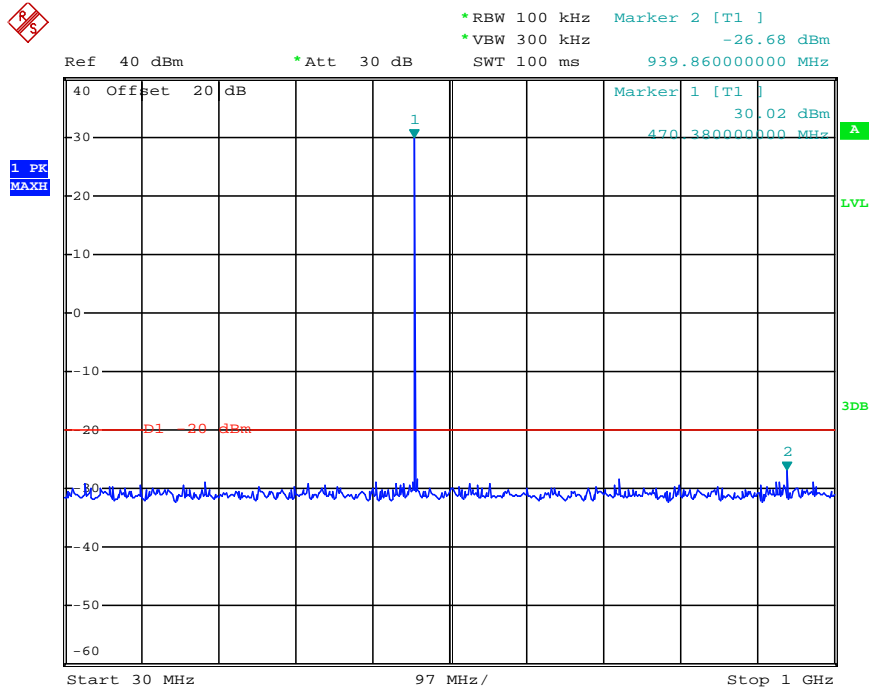

Date: 21.JAN.2013 14:41:07

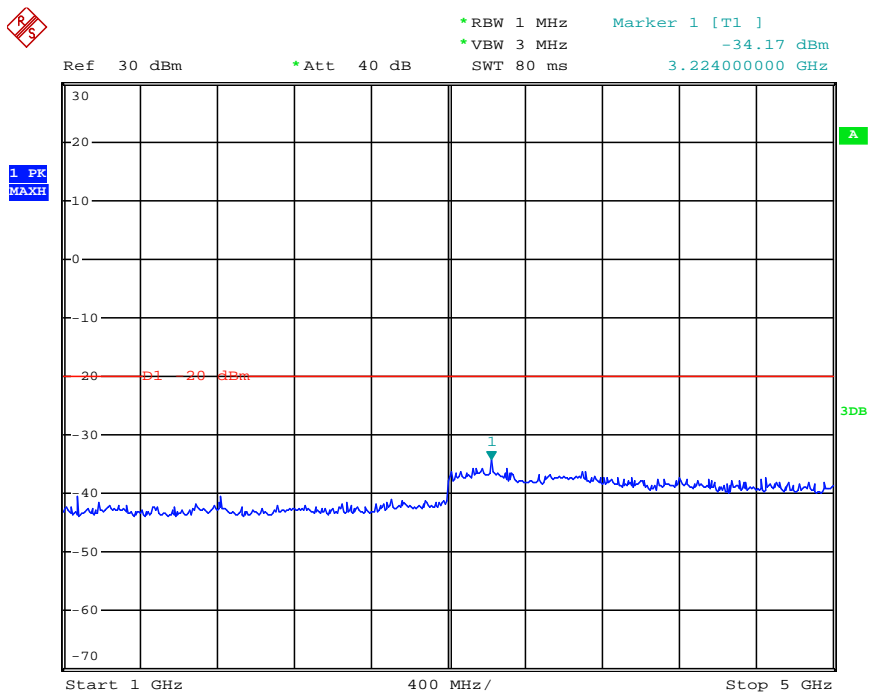

Date: 21.JAN.2013 14:53:54

Modulation Type	Channel Sparation	Test Channel	Test Frequency (MHz)	Maximum Conducted Spurious Emissions Below 1GHz		Maximum Conducted Spurious Emissions Above 1GHz		FCC Limit
				Frequency (MHz)	Datum (dBm)	Frequency (MHz)	Datum (dBm)	
4FSk	12.5KHz	Low	406.5000	813.76	-27.89	3272.00	-35.19	-20dBm
Test Results				Compliance				

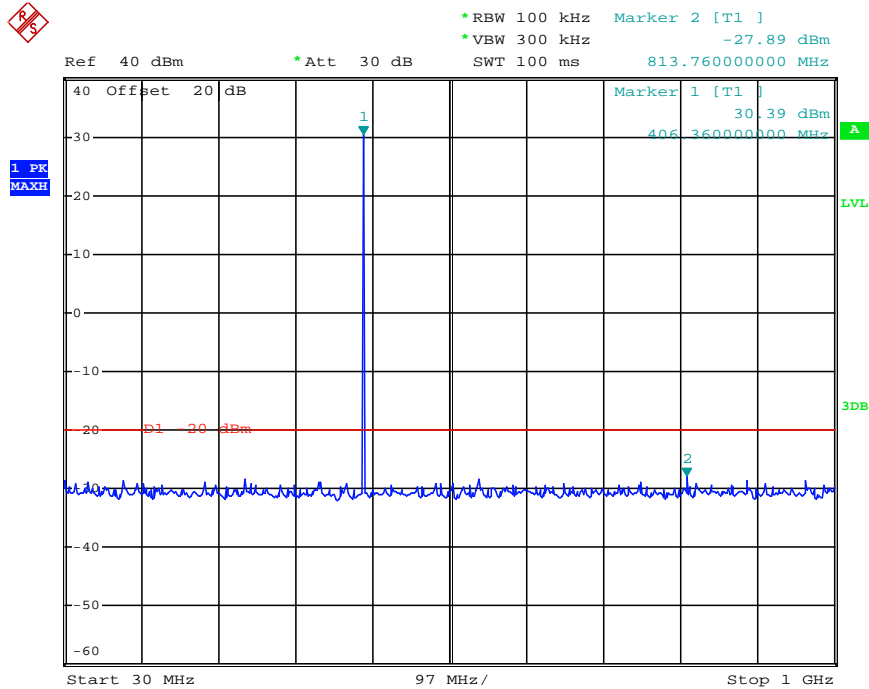

Date: 21.JAN.2013 14:41:32

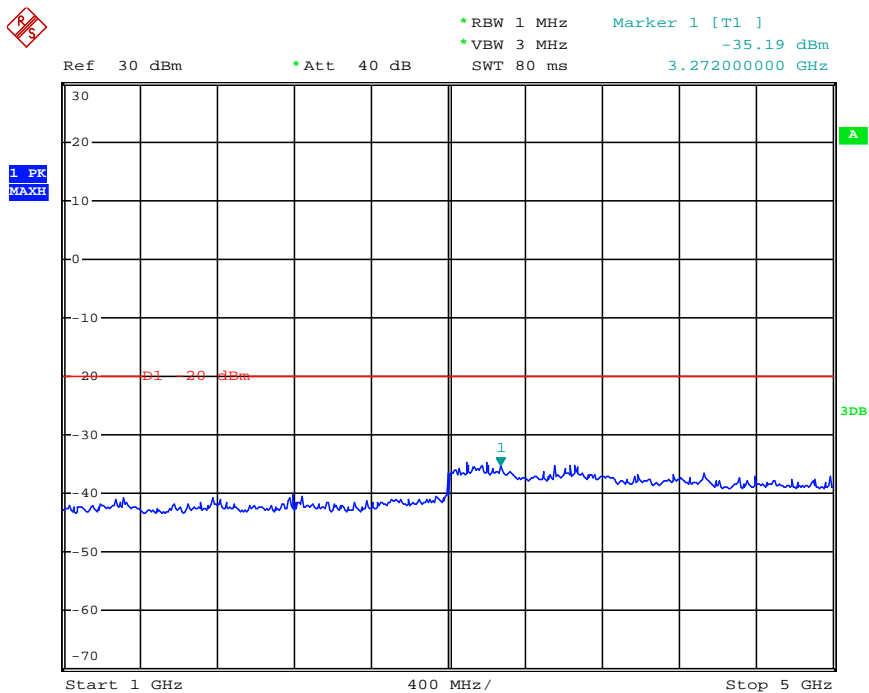

Date: 21.JAN.2013 14:55:07

Modulation Type	Channel SpARATION	Test Channel	Test Frequency (MHz)	Maximum Conducted Spurious Emissions Below 1GHz		Maximum Conducted Spurious Emissions Above 1GHz		FCC Limit
				Frequency (MHz)	Datum (dBm)	Frequency (MHz)	Datum (dBm)	
4FSk	12.5KHz	Low	418.0000	837.04	-26.90	3224.00	-34.76	-20dBm
Test Results				Compliance				

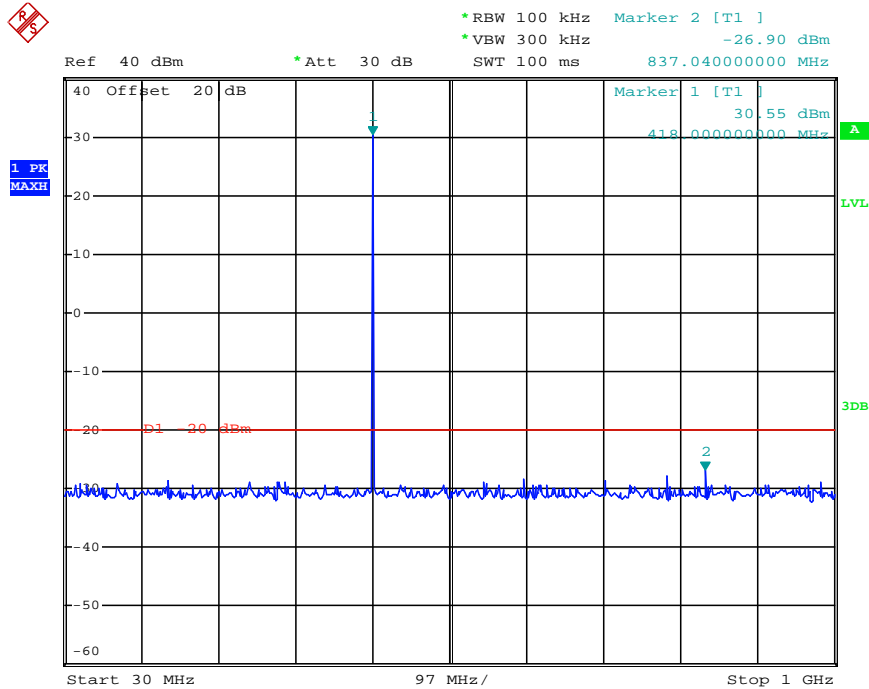

Date: 21.JAN.2013 14:41:58

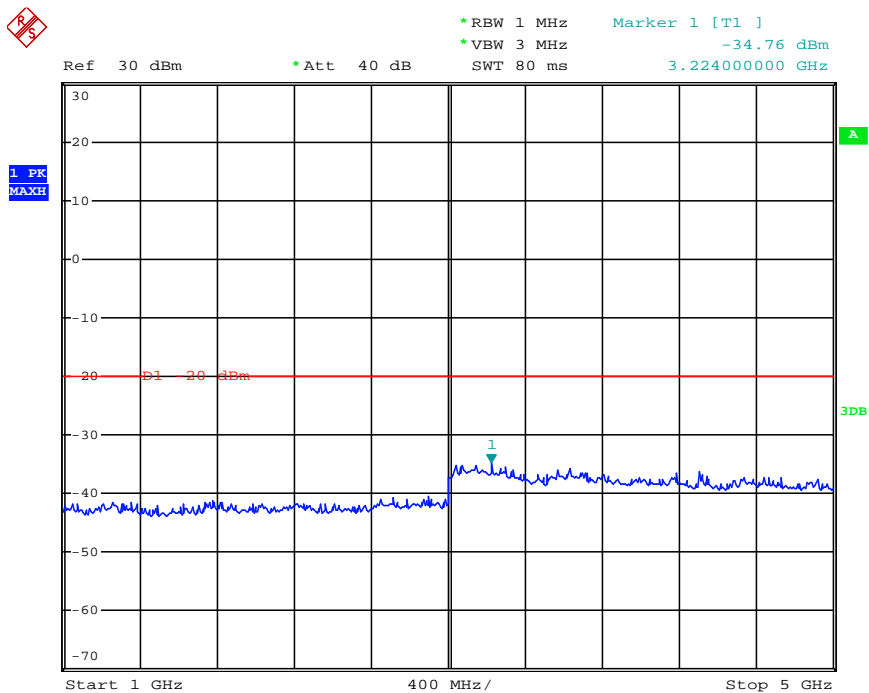

Date: 21.JAN.2013 14:55:29

Modulation Type	Channel SpARATION	Test Channel	Test Frequency (MHz)	Maximum Conducted Spurious Emissions Below 1GHz		Maximum Conducted Spurious Emissions Above 1GHz		FCC Limit
				Frequency (MHz)	Datum (dBm)	Frequency (MHz)	Datum (dBm)	
4FSK	12.5KHz	Middle	435.5000	871.96	-26.95	3264.00	-36.17	-20dBm
Test Results				Compliance				

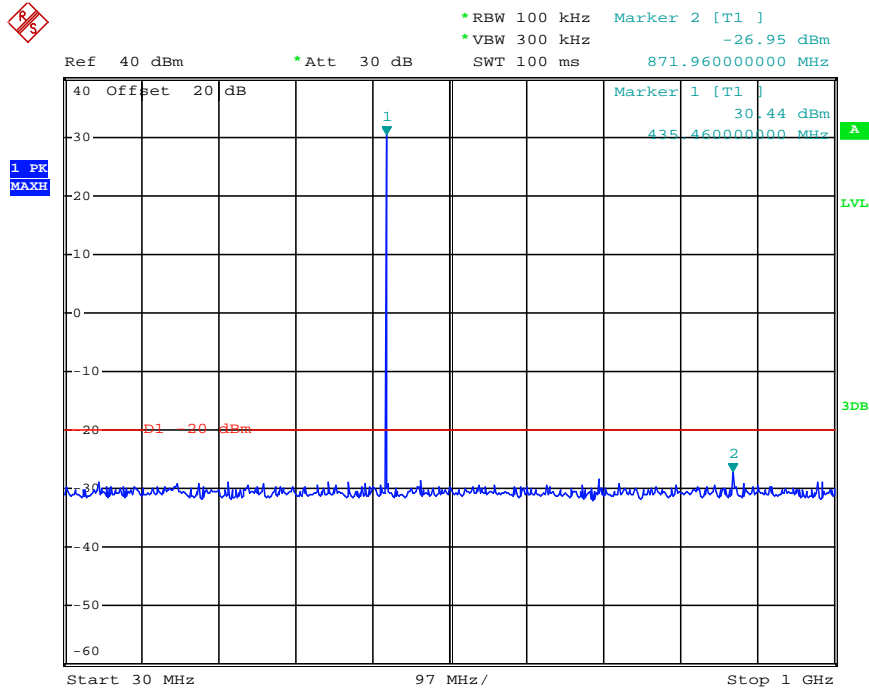

Date: 21.JAN.2013 14:42:26

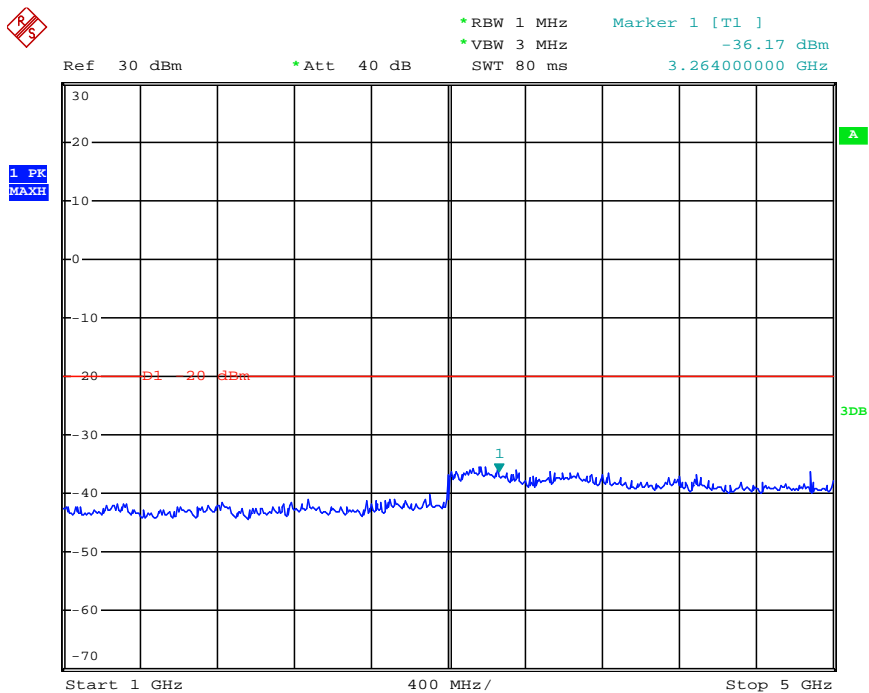

Date: 21.JAN.2013 14:55:41

Modulation Type	Channel SpARATION	Test Channel	Test Frequency (MHz)	Maximum Conducted Spurious Emissions Below 1GHz		Maximum Conducted Spurious Emissions Above 1GHz		FCC Limit
				Frequency (MHz)	Datum (dBm)	Frequency (MHz)	Datum (dBm)	
4FSK	12.5KHz	Middle	453.0000	904.94	-28.43	3136.00	-35.13	-20dBm
Test Results				Compliance				

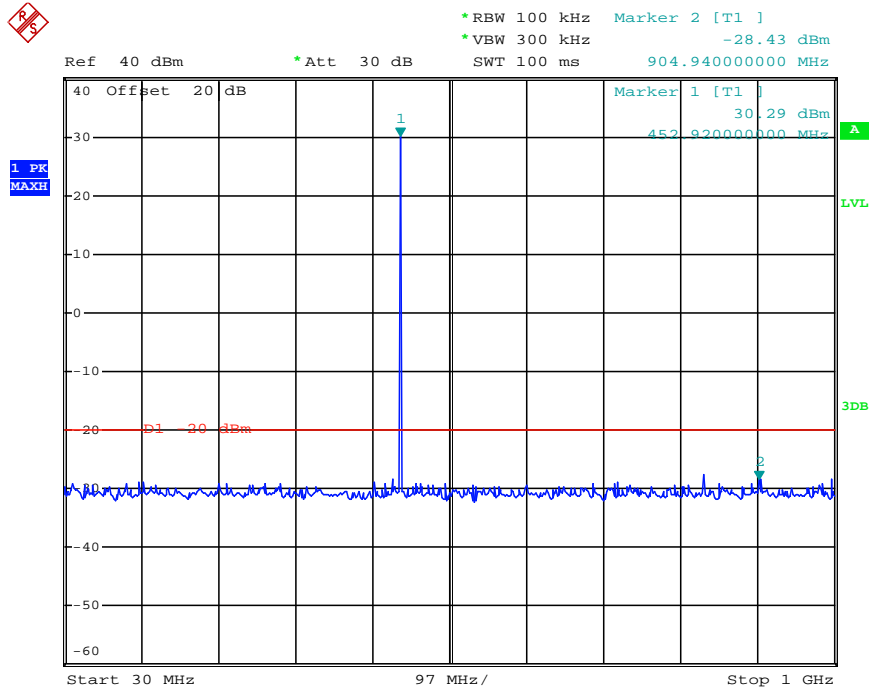

Date: 21.JAN.2013 14:42:50

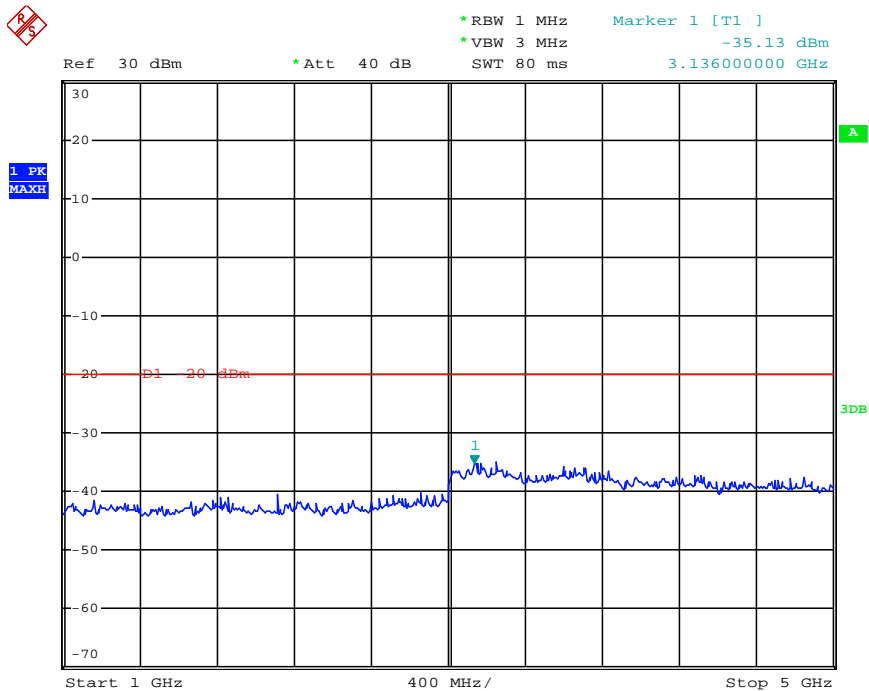

Date: 21.JAN.2013 14:55:52

Modulation Type	Channel SpARATION	Test Channel	Test Frequency (MHz)	Maximum Conducted Spurious Emissions Below 1GHz		Maximum Conducted Spurious Emissions Above 1GHz		FCC Limit
				Frequency (MHz)	Datum (dBm)	Frequency (MHz)	Datum (dBm)	
4FSK	12.5KHz	High	469.5000	939.86	-25.40	3176.00	-36.05	-20dBm
Test Results				Compliance				

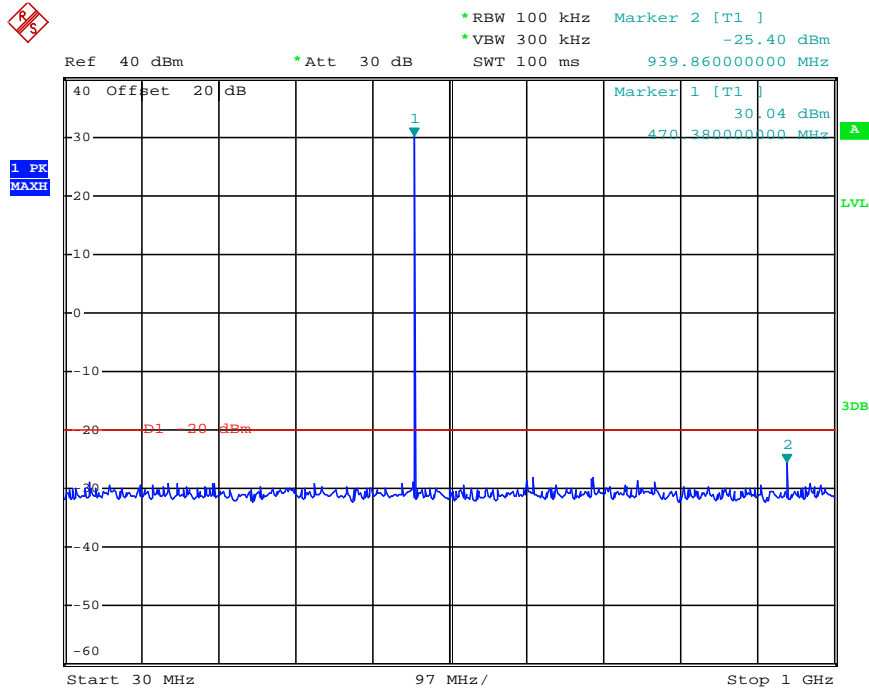

Date: 21.JAN.2013 14:43:07

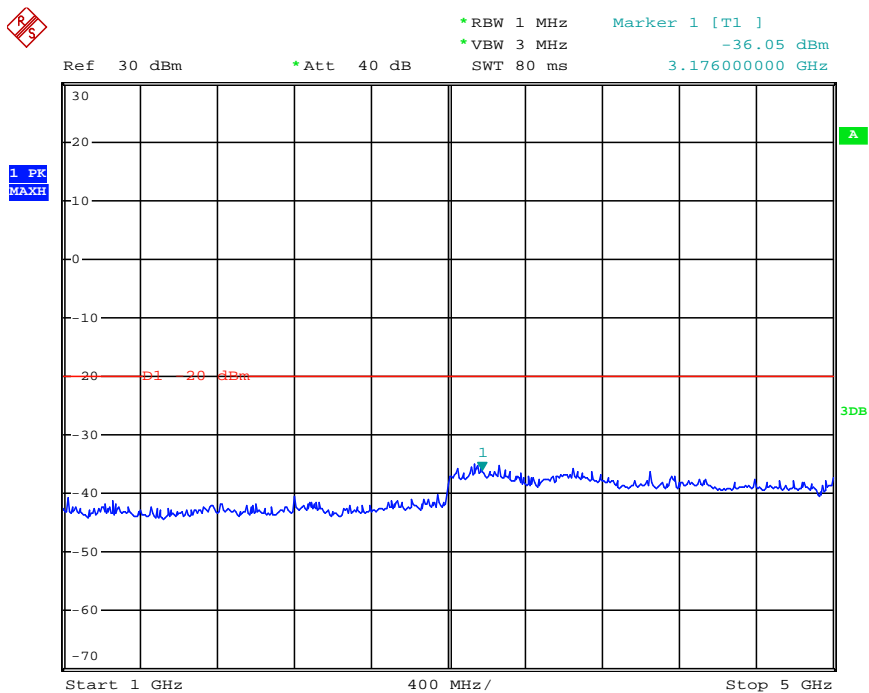

Date: 21.JAN.2013 14:54:24

4.5. Modulation Characteristics

TEST APPLICABLE

According to CFR47 section 2.1047(a), for Voice Modulation Communication Equipment, the frequency response of the audio modulation circuit over a range of 100 to 5000Hz shall be measured.

TEST PROCEDURE

Modulation Limit

- 1 Configure the EUT as shown in figure 1, adjust the audio input for 60% of rated system deviation at 1 KHz using this level as a reference (0dB) and vary the input level from -20 to +20dB. Record the frequency deviation obtained as a function of the input level.
- 2 Repeat step 1 with input frequency changing to 300, 1004, 1500 and 2500Hz in sequence.

Audio Frequency Response

- 1 Configure the EUT as shown in figure 1.
- 2 Adjust the audio input for 20% of rated system deviation at 1 KHz using this level as a reference (0dB).
- 3 Vary the Audio frequency from 100 Hz to 3 KHz and record the frequency deviation.
- 4 Audio Frequency Response = $20\log_{10} (\text{Deviation of test frequency} / \text{Deviation of 1 KHz reference})$.

TEST CONFIGURATION

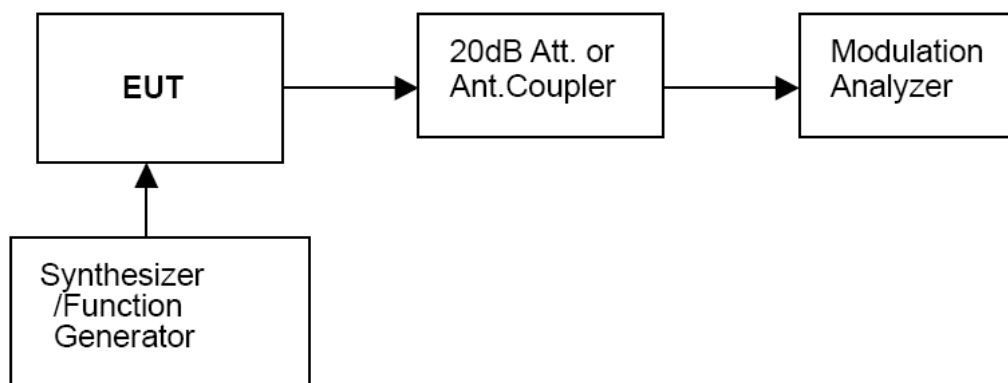

TEST RESULTS

Modulation Type: FM

12.5 KHz Channel Separation

Modulation Level(dB)	Peak Freq. Deviation At 300 Hz(KHz)	Peak Freq. Deviation At 1004 H(KHz)	Peak Freq. Deviation At 1500 Hz(KHz)	Peak Freq. Deviation At 2500 Hz(KHz)
-20	0.23	0.29	0.38	0.54
-15	0.15	0.41	0.49	0.71
-10	0.30	0.69	0.86	1.29
-5	0.40	1.01	1.38	2.17
0	0.54	1.66	2.27	2.32
+5	0.77	2.30	2.31	2.26
+10	1.26	2.30	2.27	2.25
+15	2.13	2.38	2.38	2.36
+20	2.33	2.34	2.33	2.31

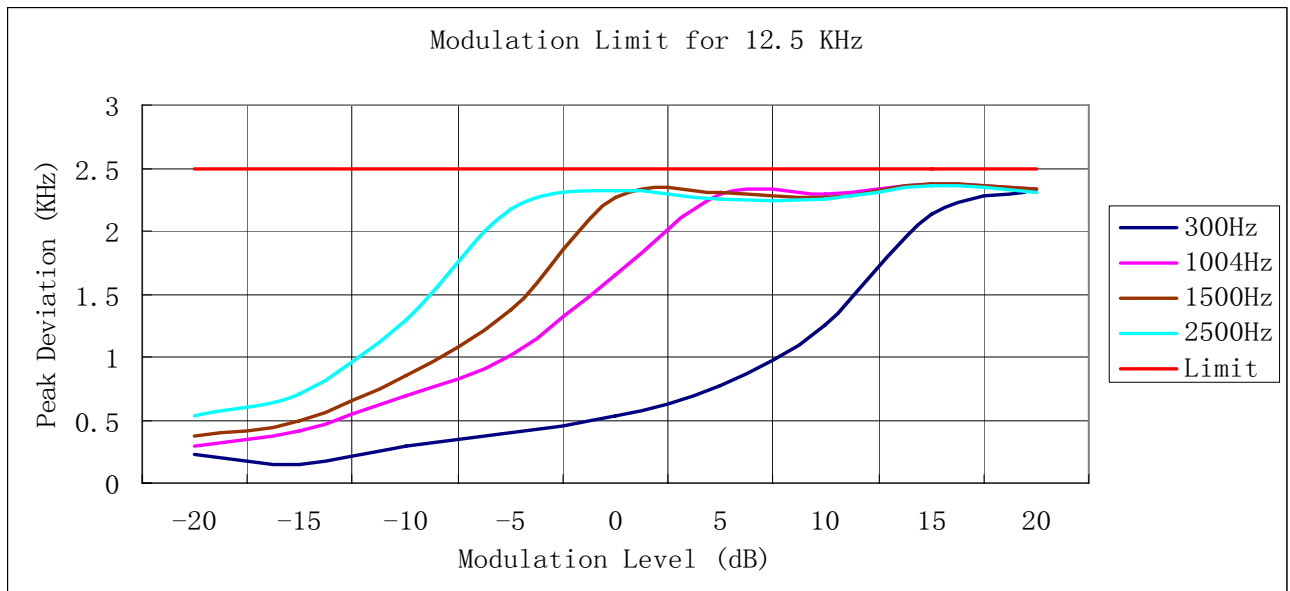

Modulation type: 4FSK

Channel bandwidth: 12.5 kHz

It is not applicable for devices which operate with the digitized voice/data modulation type.

b). Audio Frequency Response:

Rule Part No.: Part 2.1407(a) (b)

Method of Measurement:

The audio frequency response was measured in accordance with TIA/EIA Specification 603 with no exception. A curve or equivalent data showing the frequency response of the audio modulating circuit over a range of 300-3000Hz shall be submitted and Audio Post Limiter Low Pass Filter Response from 3.0 KHz to 50KHz. However, the audio frequency response should test from 100Hz to 5.0 KHz according to FCC Part 90.

Modulation Type: FM

The audio frequency response curve is show below.and

Test Audio Level (1 KHz and 20% maximum deviation) for 2.70mv for 12.5 KHz channel separation.

Note:

- 1 Not applicable to new standard. However, tests are conducted under FCC's recommendation.
- 2 The Audio Frequency Response is identical for 12.5 KHz channel separation

12.5 KHz Channel Separation

Frequency (KHz)	Frequency Deviation (KHz)	1KHz Reference Deviation (KHz)	Audio Frequency Response (dB)
0.1	0.05	0.53	-20.51
0.2	0.05	0.53	-20.51
0.3	0.14	0.53	-11.56
0.4	0.16	0.53	-10.40
0.5	0.21	0.53	-8.04
0.6	0.30	0.53	-4.94
0.7	0.36	0.53	-3.36
0.8	0.36	0.53	-3.36
0.9	0.47	0.53	-1.04
1.0	0.53	0.53	0.00
1.2	0.59	0.53	0.93
1.4	0.63	0.53	1.50
1.6	0.76	0.53	3.13
1.8	0.82	0.53	3.79
2.0	0.91	0.53	4.70
2.2	1.02	0.53	5.69
2.4	1.12	0.53	6.50
2.6	1.21	0.53	7.17
2.7	1.23	0.53	7.31
2.8	1.22	0.53	7.24
3.0	1.26	0.53	7.52
3.5	0.05	0.53	-20.51
4.0	0.04	0.53	-22.44
4.5	0.03	0.53	-24.94
5.0	0.03	0.53	-24.94

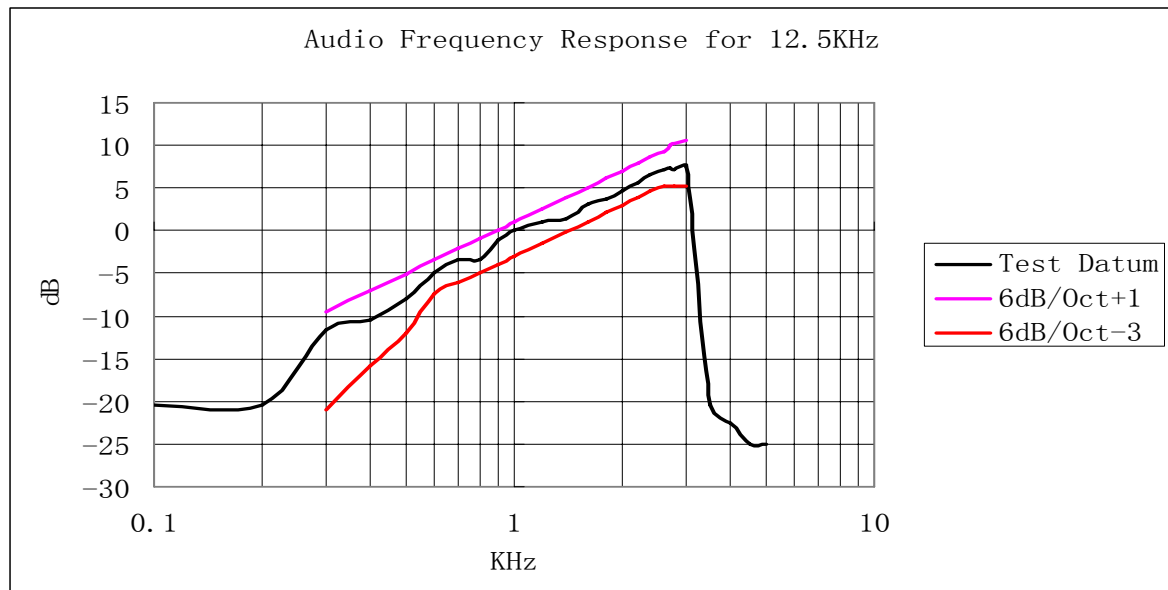

Modulation type: 4FSK

Channel bandwidth: 12.5 kHz

It is not applicable for devices which operate with the digitized voice/data modulation type.

4.6. Frequency Stability Test

TEST APPLICABLE

- 1 According to FCC Part 2 Section 2.1055 (a)(1), the frequency stability shall be measured with variation of ambient temperature from -30°C to +60°C centigrade.
- 2 According to FCC Part 2 Section 2.1055 (a) (2), for battery powered equipment, the frequency stability shall be measured with reducing primary supply voltage to the battery operating end point, which is specified by the manufacture.
- 3 Vary primary supply voltage from 85 to 115 percent of the nominal value for other than hand carried battery equipment and voltage end point was 13.60V.
- 4 According to §90.213, the frequency stability limit is 2.5 ppm for 12.5KHz channel separation

TEST PROCEDURE

The EUT was set in the climate chamber and connected to an external DC power supply. The RF output was directly connected to Spectrum Analyzer ESI 26. The coupling loss of the additional cables was recorded and taken in account for all the measurements. After temperature stabilization (approx. 20 min for each stage), the frequency for the lower, the middle and the highest frequency range was recorded. For Frequency stability Vs. Voltage the EUT was connected to a DC power supply and the voltage was adjusted in the required ranges. The result was recorded.

TEST CONFIGURATION

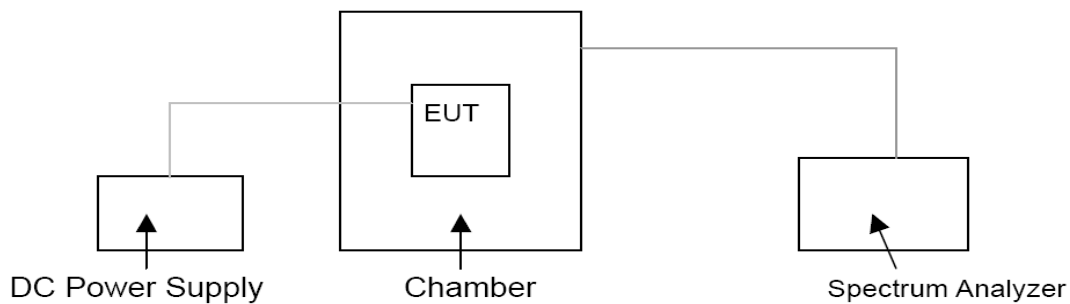

TEST LIMITS

According to 90.213, Transmitters used must have minimum frequency stability as specified in the following table.

Frequency Range (MHz)	Channel Bandwidth (KHz)	Frequency Tolerance (ppm)		
		Fixed and Base Stations	Mobile Stations	
			> 2 W	≤ 2 W
150-174 MHz	6.25	1.0	2.0	2.0
	12.5	2.5	5.0	5.0
	25	5.0	5.0	50.0*
421-512 MHz	6.25	0.5	1.0	1.0
	12.5	1.5	2.5	2.5
	25	2.5	5.0	5.0

- Stations operating in the 154.45 to 154.49 MHz or the 173.2 to 173.4 MHz bands must have a frequency stability of 5 ppm.
- Paging transmitters operating on paging-only frequencies must operate with frequency stability of 5 ppm in the 150-174 MHz band and 2.5 ppm in the 421-512 MHz band.

TEST RESULTS

Modulation Type	Channel Separation	Test conditions		Frequency error (ppm)				
		Voltage(V)	Temp(°C)	406.5	418	435.5	453	469.5
Analog/FM	12.5KHz	13.60	-30	1.31	1.16	1.40	1.18	1.33
			-20	1.21	1.17	1.15	1.05	1.04
			-10	0.98	1.16	1.10	1.23	1.02
			0	1.02	1.12	1.10	1.14	1.07
			10	0.95	1.14	1.11	1.15	0.99
			20	0.83	1.05	1.10	1.03	0.97
			30	0.86	1.10	1.13	1.00	1.04
			40	0.96	1.19	1.05	1.15	1.06
			50	1.00	1.24	1.09	1.04	1.06
			12.00(End point)	20	1.15	1.14	1.13	0.98
		11.56 (85% Rated)	20	0.86	0.99	1.12	1.00	1.02
		15.6(115% Rated)	20	1.21	1.11	1.07	0.97	0.97
Limit			2.5 ppm					
Conclusion			Complies					

Modulation Type	Channel Separation	Test conditions		Frequency error (ppm)				
		Voltage(V)	Temp(°C)	406.5	418	435.5	453	469.5
Digital/4FSK	12.5KHz	13.60	-30	1.21	1.06	1.30	1.08	1.23
			-20	1.03	0.99	0.97	0.87	0.86
			-10	0.82	1.00	0.94	1.07	0.86
			0	0.90	1.00	0.98	1.02	0.95
			10	0.83	1.02	0.99	1.03	0.87
			20	0.81	1.03	1.08	1.01	0.95
			30	0.76	1.00	1.03	0.90	0.94
			40	0.88	1.11	0.97	1.07	0.98
			50	0.90	1.14	0.99	0.94	0.96
			12.00(End point)	20	1.03	1.02	1.01	0.86
		11.56 (85% Rated)	20	0.78	0.91	1.04	0.92	0.94
		15.6(115% Rated)	20	1.09	0.99	0.95	0.85	0.85
Limit			2.5 ppm					
Conclusion			Complies					

4.7. Maximum Transmitter Power

TEST APPLICABLE

Per RSS-119 Section 5.4 and 5.4.1: The output power shall be within ± 1.0 dB of the manufacturer's rated power. Typical transmitter output powers are 110 watts for base and/or fixed stations (paging transmitters excepted), and 30 watts for mobile stations. Higher powers may be certified, but it should be noted that mobile stations are normally only licensed up to 30 watts. See the SRSP relevant to the operating frequency for equipment power limits.

TEST PROCEDURE

Measurements shall be made to establish the radio frequency power delivered by the transmitter the standard output termination. The power output shall be monitored and recorded and no adjustment shall be made to the transmitter after the test has begun, except as noted below:

If the power output is adjustable, measurements shall be made for the highest and lowest power levels.

The EUT connect to the Receiver through 20 dB attenuator.

Measurement with Spectrum Analyzer FSP40 conducted, external power supply with 13.60 V stabilized supply voltage.

TEST CONFIGURATION

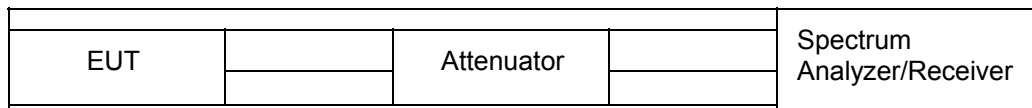

The EUT was directly connected to a RF Communication Test set by a 20 dB attenuator

TEST RESULTS

Modulation Type	Channel Separation	Test Channel	Test Frequency	Maximum Transmitter Power at Rated High Power Level(dBm)	Maximum Transmitter Power at Rated Low Power Level(dBm)
Analog/FM	12.5KHz	Low Channel	406.5000 MHz	40.30	30.43
		Low Channel	418.0000 MHz	40.16	30.58
		Middle Channel	435.5000 MHz	40.10	30.53
		High Channel	453.0000 MHz	40.11	30.42
		High Channel	469.5000 MHz	40.07	30.23
Digital/4FSK	12.5KHz	Low Channel	406.5000 MHz	40.41	30.42
		Low Channel	418.0000 MHz	40.36	30.57
		Middle Channel	435.5000 MHz	40.29	30.52
		High Channel	453.0000 MHz	40.31	30.41
		High Channel	469.5000 MHz	40.24	30.21
Limit		The limit is dependent upon the station's antenna HAAT and required service area.			
Test Results		Complicance			

Plots of Maximum Transmitter Power Measurement

Modulation Type	Channel Separation	Freq.(MHz)	Rated Power (Watt)	Measurement (dBm)	FCC Limit	Results
FM	12.5 KHz	406.5000	10	40.30	Varies	Compliance

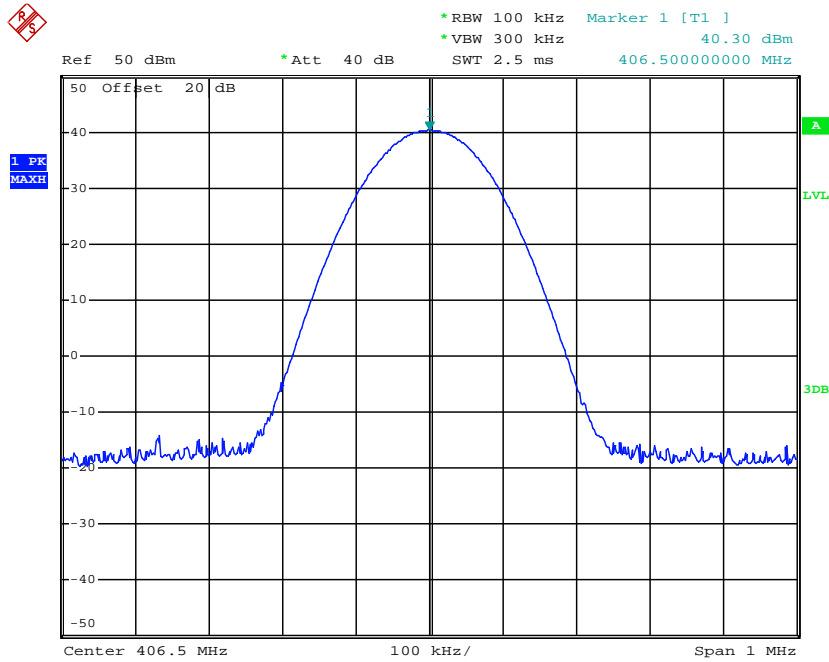

Date: 21.JAN.2013 14:26:24

Modulation Type	Channel Separation	Freq.(MHz)	Rated Power (Watt)	Measurement (dBm)	FCC Limit	Results
FM	12.5 KHz	418.0000	10	40.16	Varies	Compliance

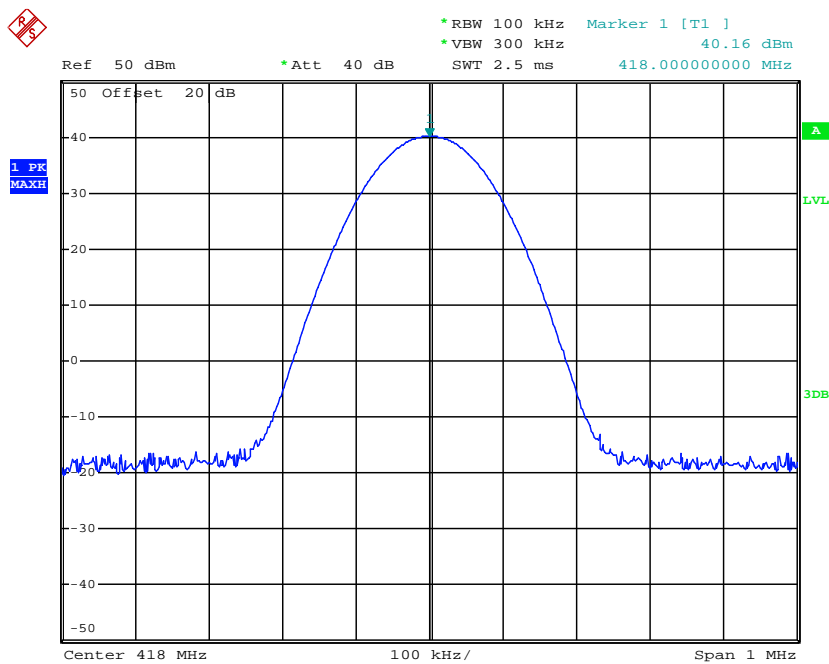

Date: 21.JAN.2013 14:26:55

Modulation Type	Channel Separation	Freq.(MHz)	Rated Power (Watt)	Measurement (dBm)	FCC Limit	Results
FM	12.5 KHz	435.5000	10	40.10	Varies	Compliance

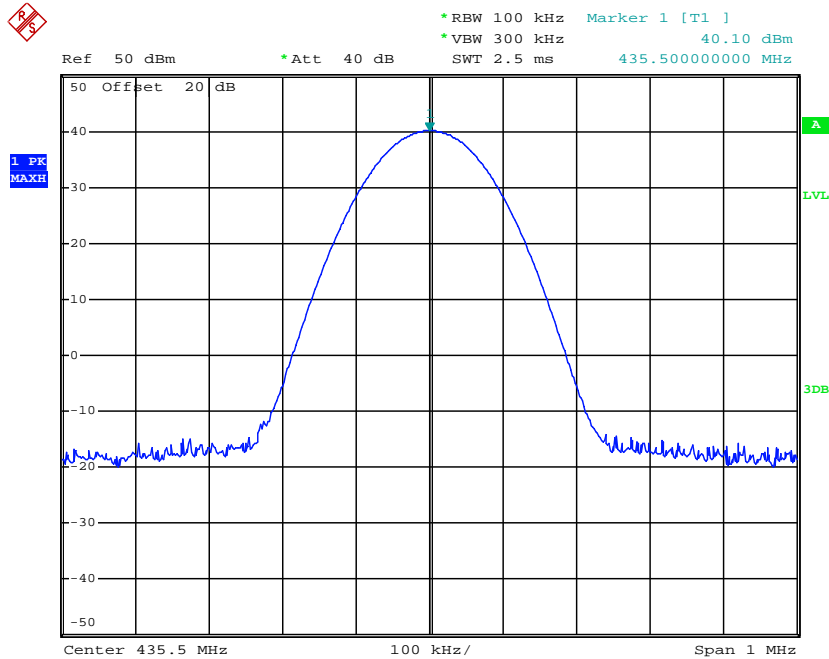

Date: 21.JAN.2013 14:27:25

Modulation Type	Channel Separation	Freq.(MHz)	Rated Power (Watt)	Measurement (dBm)	FCC Limit	Results
FM	12.5 KHz	453.0000	10	40.11	Varies	Compliance

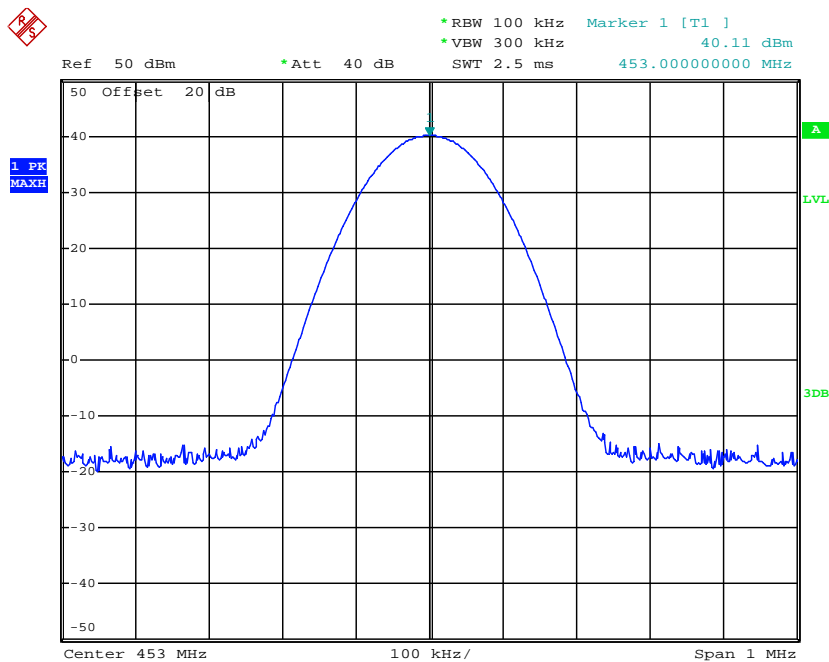

Date: 21.JAN.2013 14:27:51

Modulation Type	Channel Separation	Freq.(MHz)	Rated Power (Watt)	Measurement (dBm)	FCC Limit	Results
FM	12.5 KHz	469.5000	10	40.07	Varies	Compliance

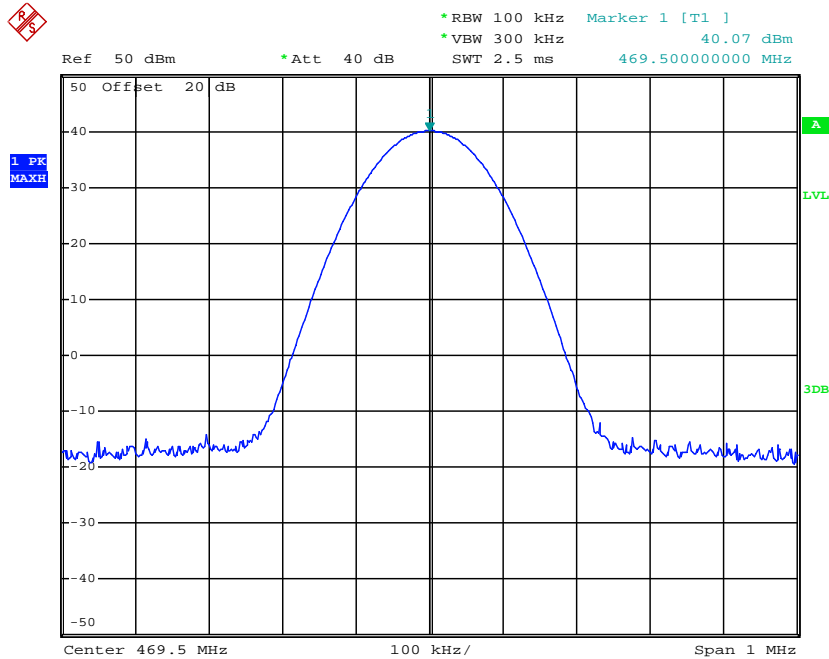

Date: 21.JAN.2013 14:28:27

Modulation Type	Channel Separation	Freq.(MHz)	Rated Power (Watt)	Measurement (dBm)	FCC Limit	Results
4FSK	12.5 KHz	406.5000	10	40.41	Varies	Compliance

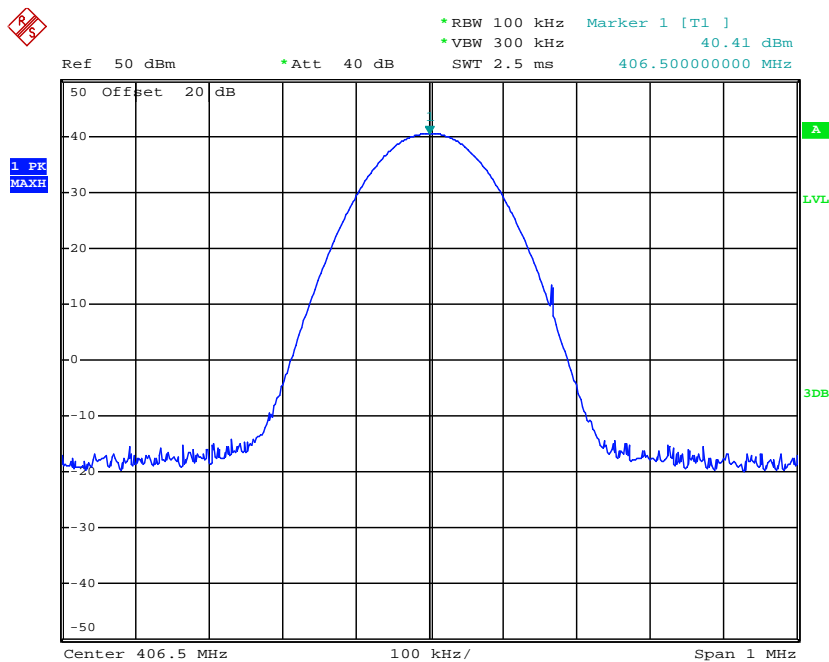

Date: 23.JAN.2013 14:55:17

Modulation Type	Channel Separation	Freq.(MHz)	Rated Power (Watt)	Measurement (dBm)	FCC Limit	Results
4FSK	12.5 KHz	418.0000	10	40.36	Varies	Compliance

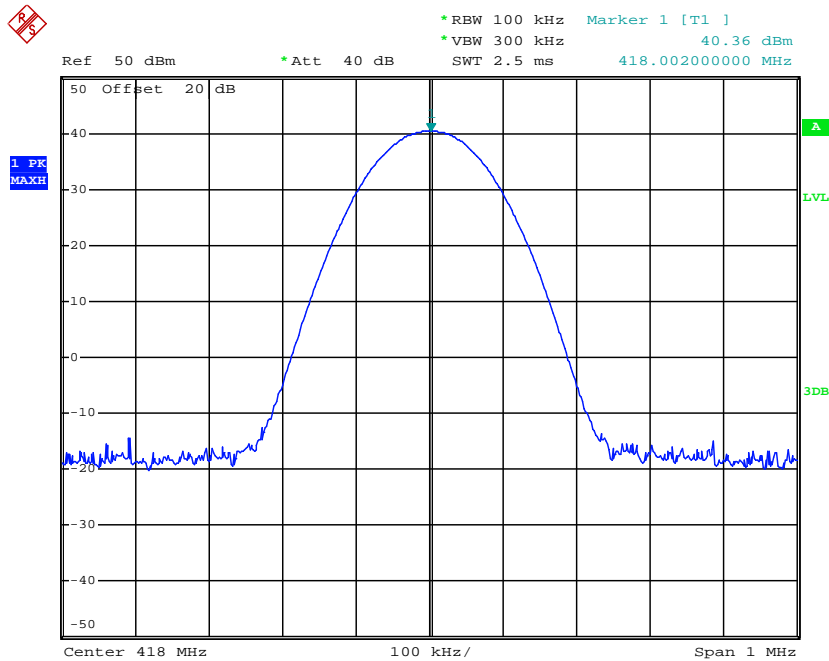

Date: 23.JAN.2013 14:55:42

Modulation Type	Channel Separation	Freq.(MHz)	Rated Power (Watt)	Measurement (dBm)	FCC Limit	Results
4FSK	12.5 KHz	435.5000	10	40.29	Varies	Compliance

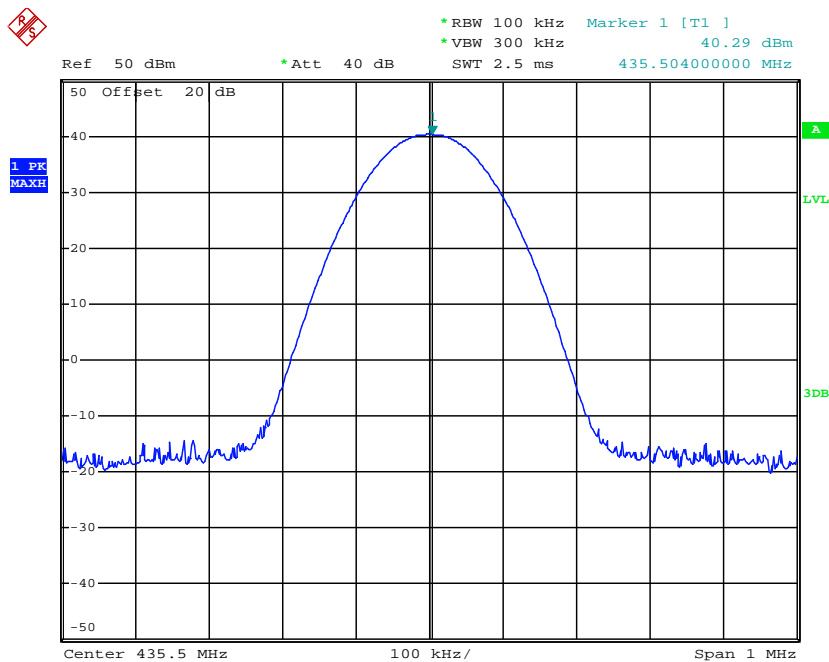

Date: 23.JAN.2013 14:55:58

Modulation Type	Channel Separation	Freq.(MHz)	Rated Power (Watt)	Measurement (dBm)	FCC Limit	Results
4FSK	12.5 KHz	453.0000	10	40.31	Varies	Compliance

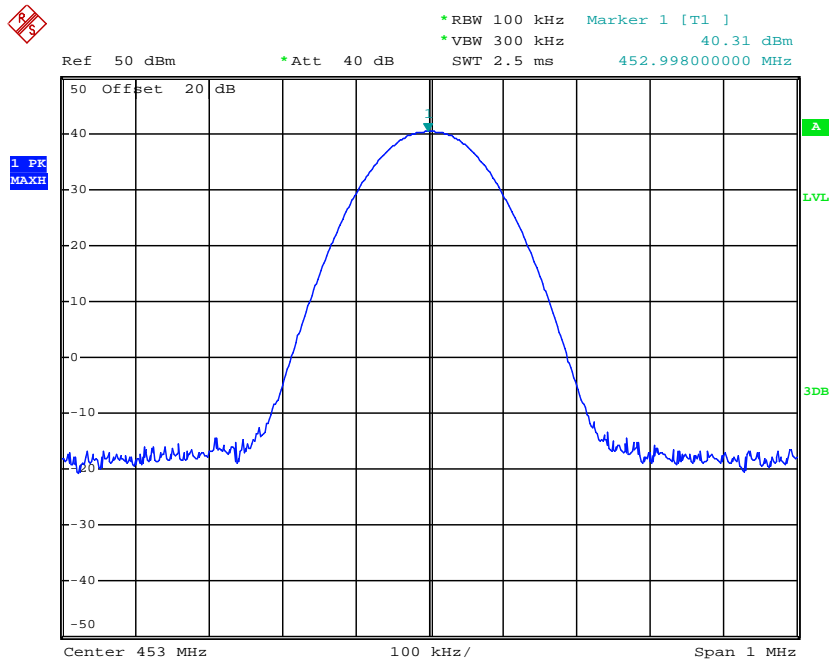

Date: 23.JAN.2013 14:56:16

Modulation Type	Channel Separation	Freq.(MHz)	Rated Power (Watt)	Measurement (dBm)	FCC Limit	Results
4FSK	12.5 KHz	469.5000	10	40.24	Varies	Compliance

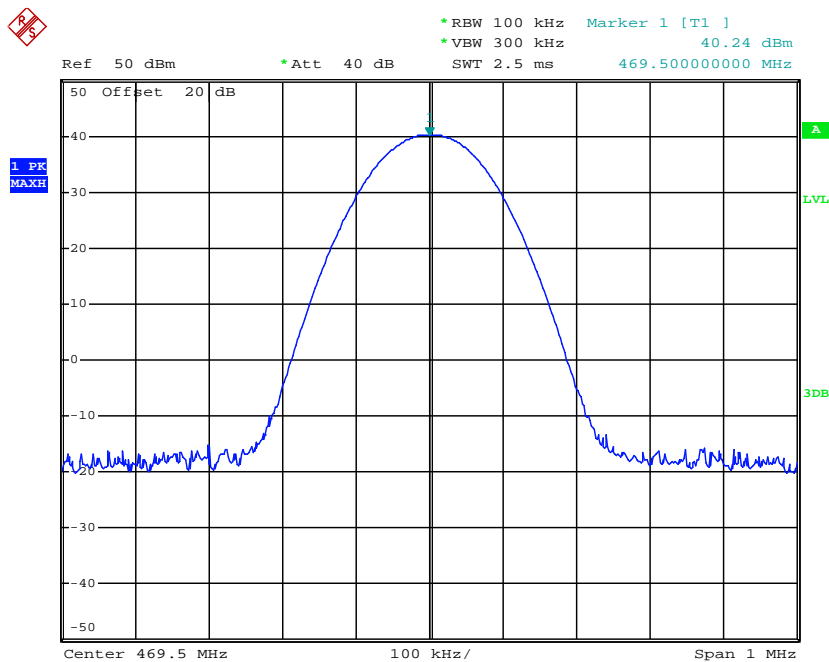

Date: 23.JAN.2013 14:56:32

Modulation Type	Channel Separation	Freq.(MHz)	Rated Power (Watt)	Measurement (dBm)	FCC Limit	Results
FM	12.5 KHz	406.5000	1	30.43	Varies	Complicance

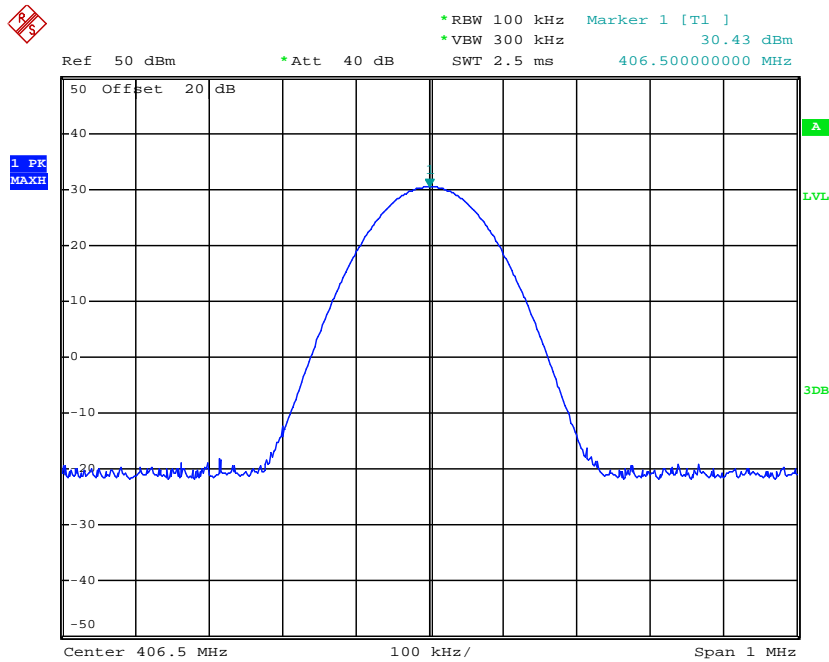

Date: 21.JAN.2013 14:28:55

Modulation Type	Channel Separation	Freq.(MHz)	Rated Power (Watt)	Measurement (dBm)	FCC Limit	Results
FM	12.5 KHz	418.0000	1	30.58	Varies	Complicance

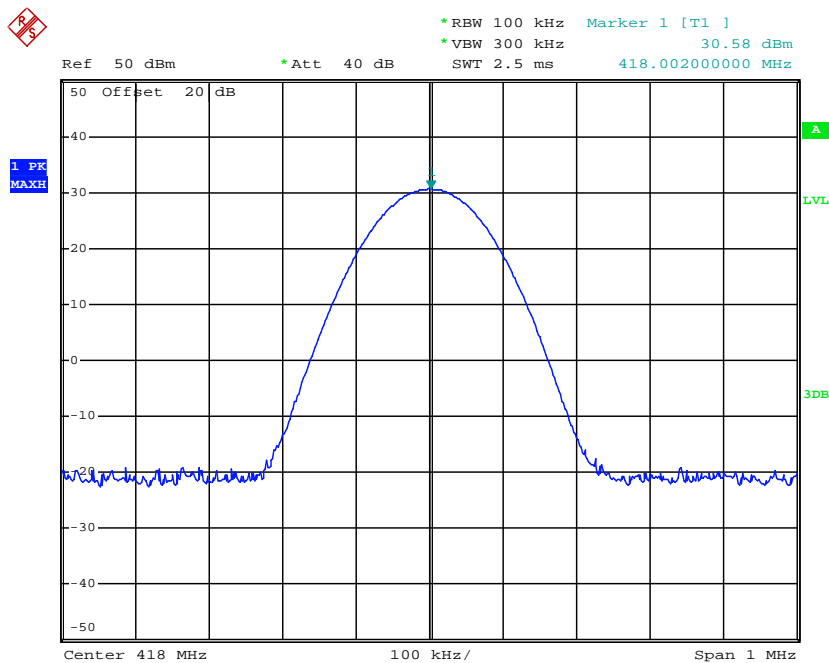

Date: 21.JAN.2013 14:29:16

Modulation Type	Channel Separation	Freq.(MHz)	Rated Power (Watt)	Measurement (dBm)	FCC Limit	Results
FM	12.5 KHz	435.5000	1	30.53	Varies	Compliance

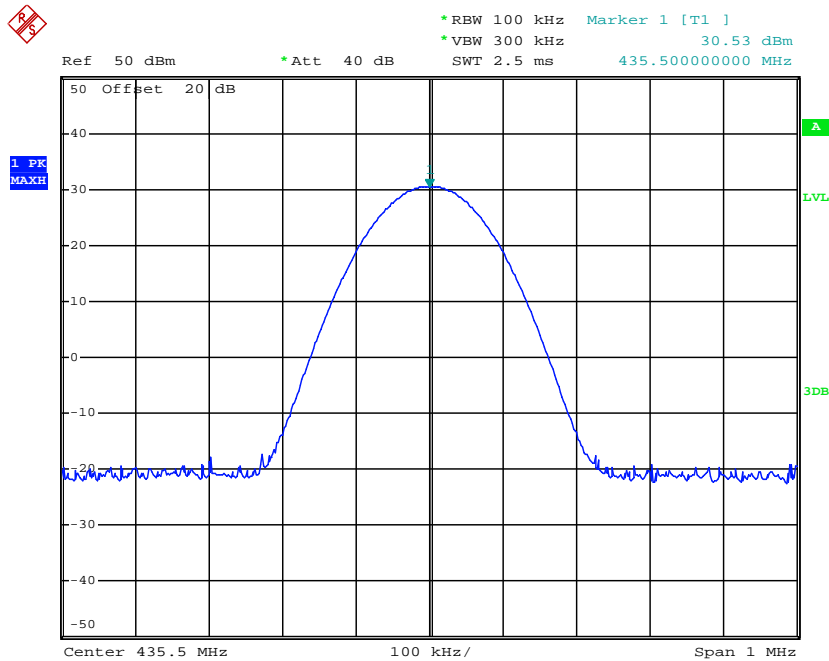

Date: 21.JAN.2013 14:29:35

Modulation Type	Channel Separation	Freq.(MHz)	Rated Power (Watt)	Measurement (dBm)	FCC Limit	Results
FM	12.5 KHz	453.0000	1	30.42	Varies	Compliance

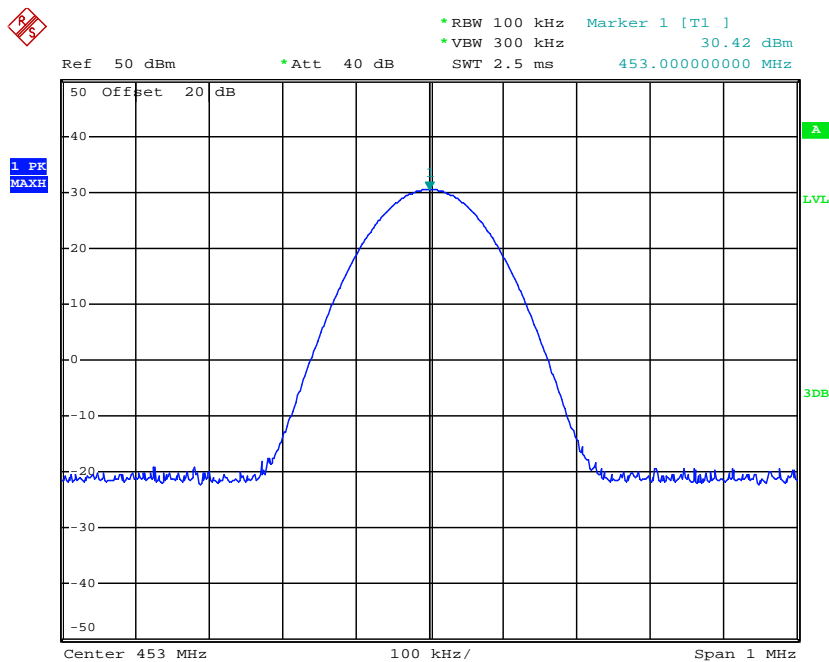

Date: 21.JAN.2013 14:29:55

Modulation Type	Channel Separation	Freq.(MHz)	Rated Power (Watt)	Measurement (dBm)	FCC Limit	Results
FM	12.5 KHz	469.5000	1	30.23	Varies	Compliance

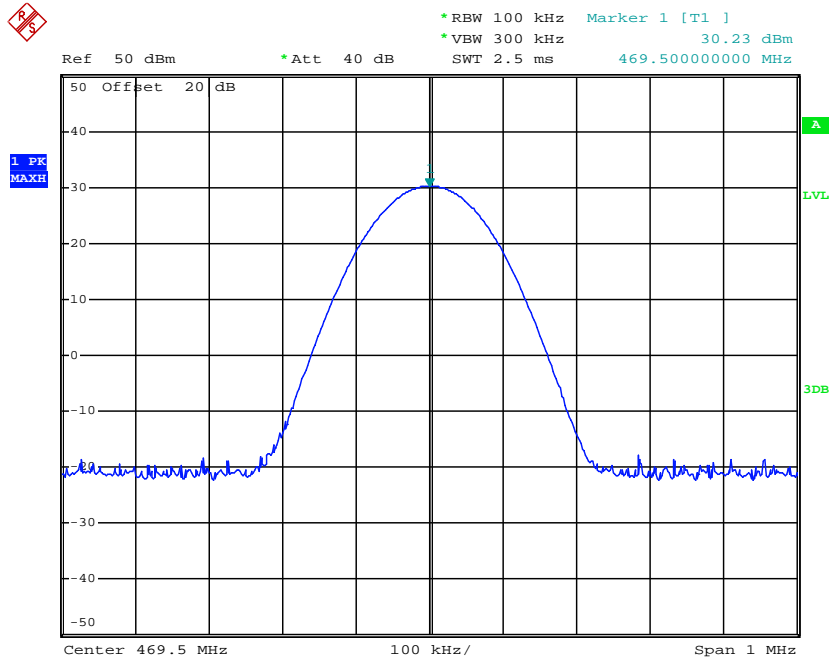

Date: 21.JAN.2013 14:30:16

Modulation Type	Channel Separation	Freq.(MHz)	Rated Power (Watt)	Measurement (dBm)	FCC Limit	Results
4FSK	12.5 KHz	406.5000	1	30.42	Varies	Compliance

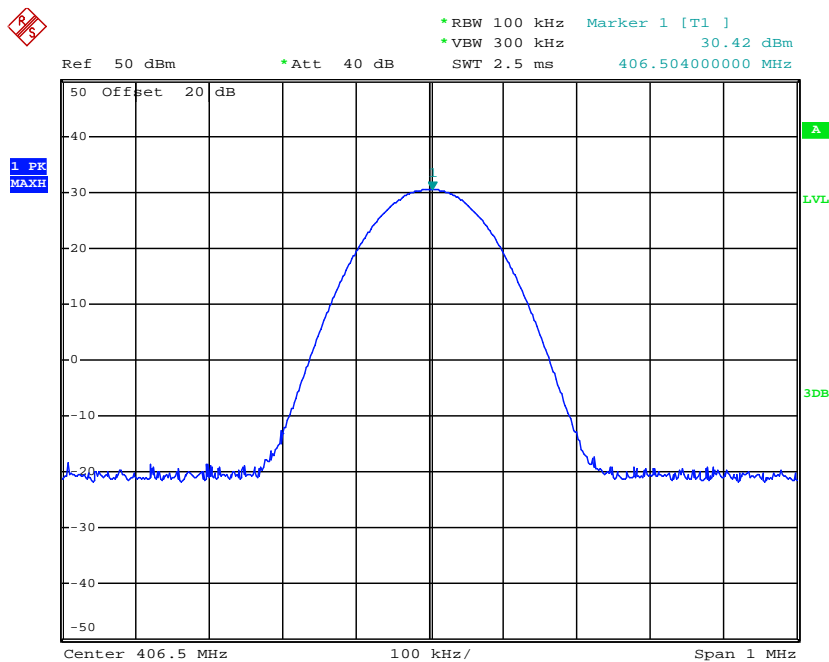

Date: 21.JAN.2013 14:30:49

Modulation Type	Channel Separation	Freq.(MHz)	Rated Power (Watt)	Measurement (dBm)	FCC Limit	Results
4FSK	12.5 KHz	418.0000	1	30.57	Varies	Compliance

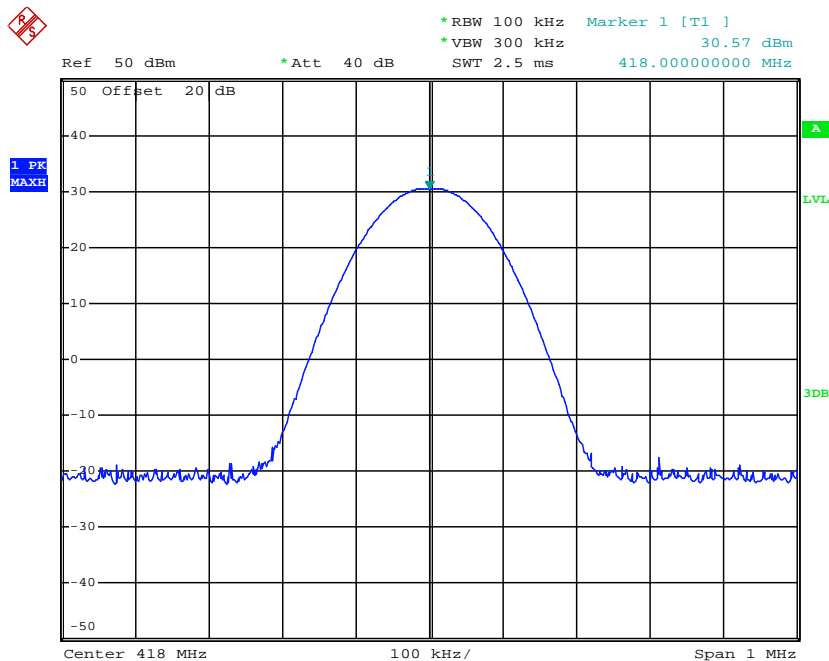

Date: 21.JAN.2013 14:31:09

Modulation Type	Channel Separation	Freq.(MHz)	Rated Power (Watt)	Measurement (dBm)	FCC Limit	Results
4FSK	12.5 KHz	435.5000	1	30.52	Varies	Compliance

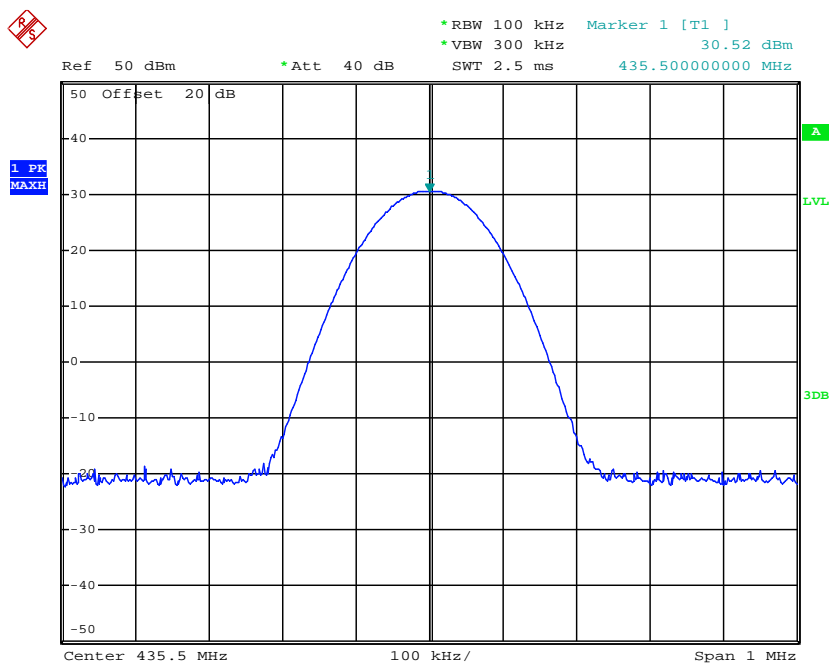

Date: 21.JAN.2013 14:31:31

Modulation Type	Channel Separation	Freq.(MHz)	Rated Power (Watt)	Measurement (dBm)	FCC Limit	Results
4FSK	12.5 KHz	453.0000	1	30.41	30.00±1	Compliance

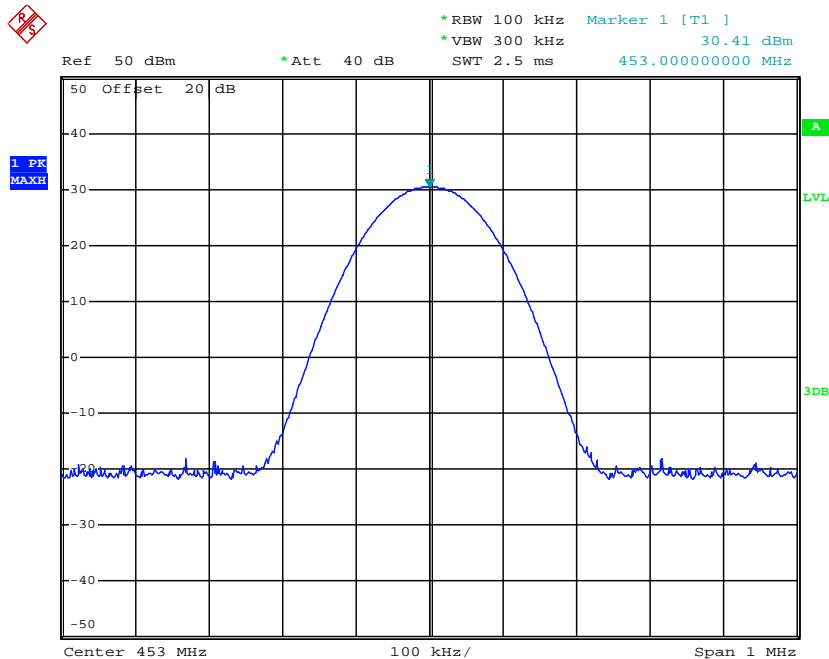

Date: 21.JAN.2013 14:31:57

Modulation Type	Channel Separation	Freq.(MHz)	Rated Power (Watt)	Measurement (dBm)	FCC Limit	Results
4FSK	12.5 KHz	469.5000	1	30.21	Varies	Compliance

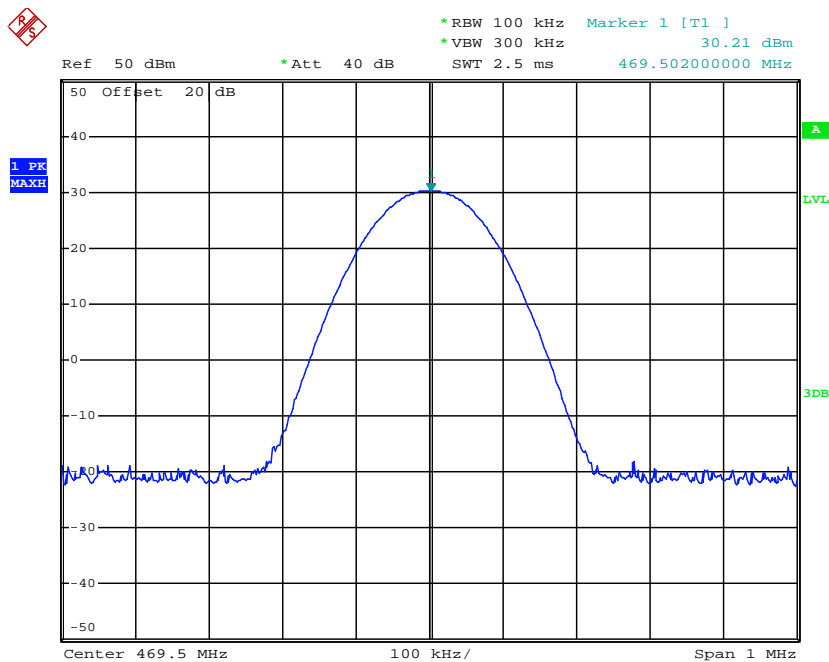

Date: 21.JAN.2013 14:32:20

4.8. Transmitter Frequency Behavior

TEST APPLICABLE

Section 90.214

Transient frequencies must be within the maximum frequency difference limits during the time intervals indicated:

Time intervals ^{1, 2}	Maximum frequency difference ³	All equipment	
		150 to 174 MHz	421 to 512MHz
Transient Frequency Behavior for Equipment Designed to Operate on 25 KHz Channels			
t_1 ⁴	± 25.0 KHz	5.0 ms	10.0 ms
t_2	± 12.5 KHz	20.0 ms	25.0 ms
t_3 ⁴	± 25.0 KHz	5.0 ms	10.0 ms
Transient Frequency Behavior for Equipment Designed to Operate on 12.5 KHz Channels			
t_1 ⁴	± 12.5 KHz	5.0 ms	10.0 ms
t_2	± 6.25 KHz	20.0 ms	25.0 ms
t_3 ⁴	± 12.5 KHz	5.0 ms	10.0 ms
Transient Frequency Behavior for Equipment Designed to Operate on 6.25 KHz Channels			
t_1 ⁴	±6.25 KHz	5.0 ms	10.0 ms
t_2	±3.125 KHz	20.0 ms	25.0 ms
t_3 ⁴	±6.25 KHz	5.0 ms	10.0 ms

- t_{on} is the instant when a 1 KHz test signal is completely suppressed, including any capture time due to phasing.
 t_1 is the time period immediately following t_{on} .
 t_2 is the time period immediately following t_1 .
 t_3 is the time period from the instant when the transmitter is turned off until t_{off} .
 t_{off} is the instant when the 1 KHz test signal starts to rise.
- During the time from the end of t_2 to the beginning of t_3 , the frequency difference must not exceed the limits specified in § 90.213.
- Difference between the actual transmitter frequency and the assigned transmitter frequency.
- If the transmitter carrier output power rating is 6 watts or less, the frequency difference during this time period may exceed the maximum frequency difference for this time period.

TEST PROCEDURE

TIA/EIA-603 2.2.19

TEST CONFIGURATION

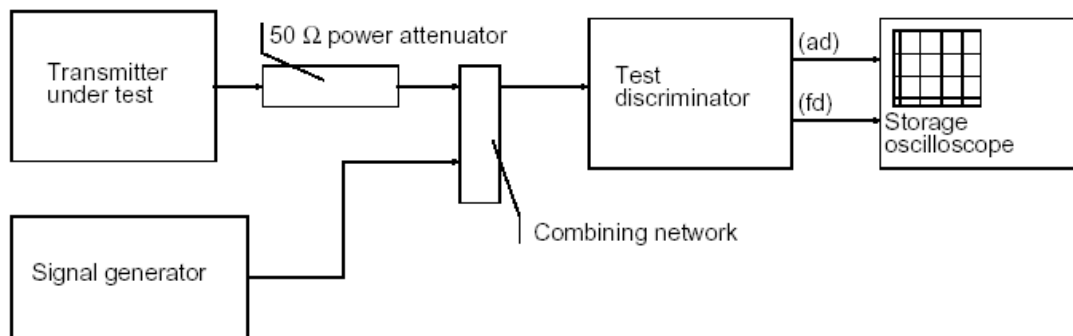

TEST RESULTS

Please refer to the following plots.

Modulation Type: FM

Transmitter Frequency Behaviour @ 12.5 KHz Channel Separation-----Off – On

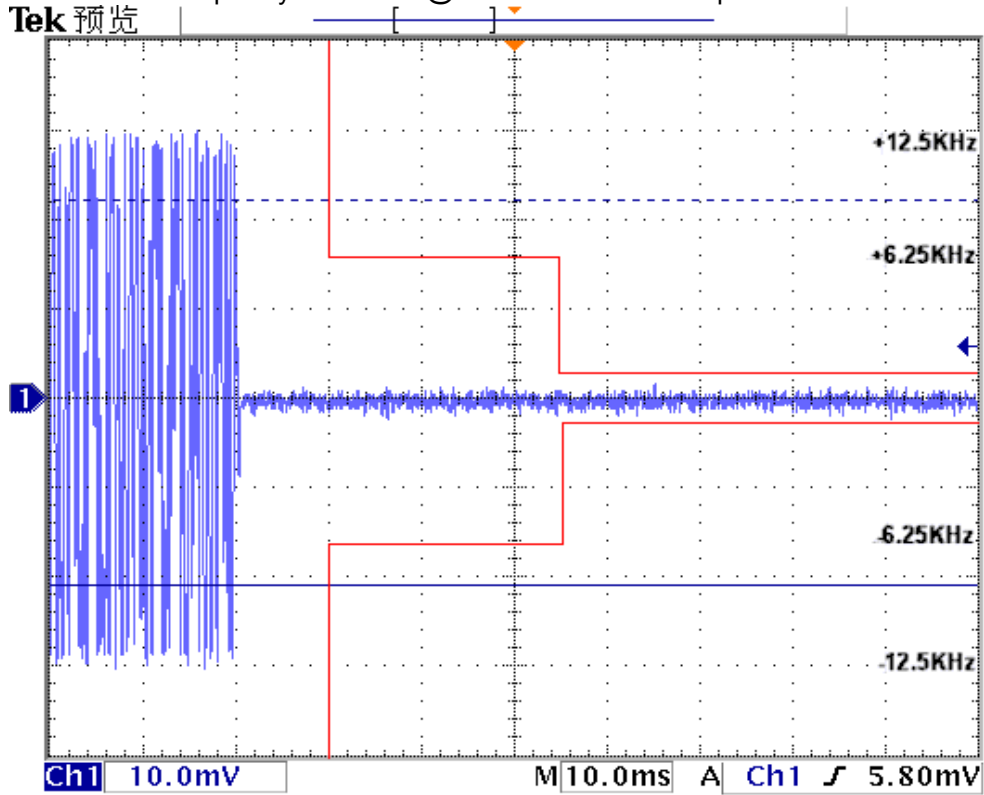

Transmitter Frequency Behaviour @ 12.5 KHz Channel Separation-----On - Off

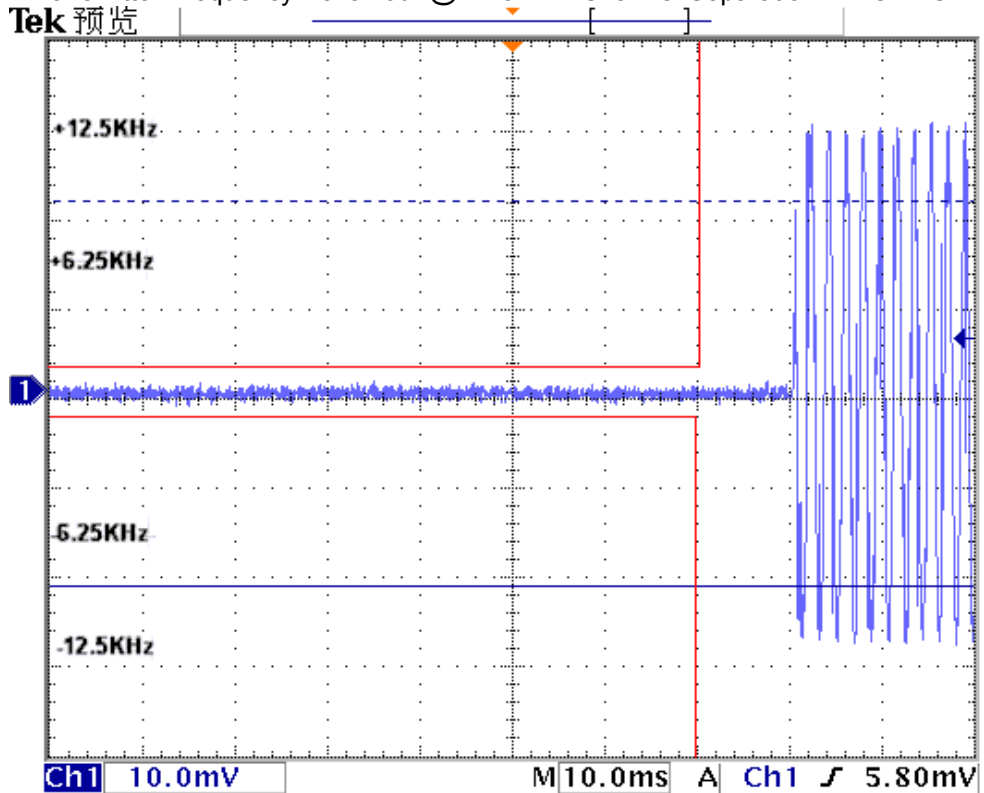

Modulation Type: 4FSK

Transmitter Frequency Behaviour @ 12.5 KHz Channel Separation-----Off – On

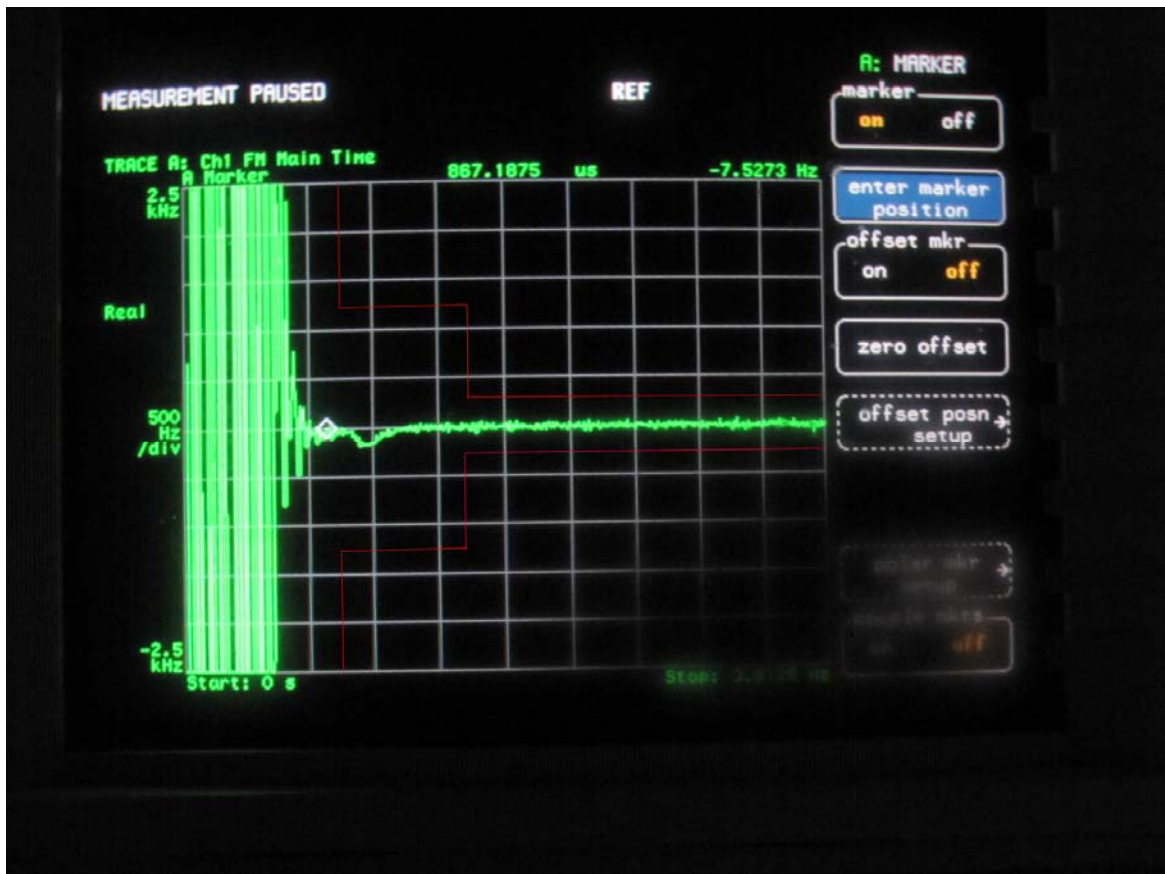

Transmitter Frequency Behaviour @ 12.5 KHz Channel Separation-----On - Off

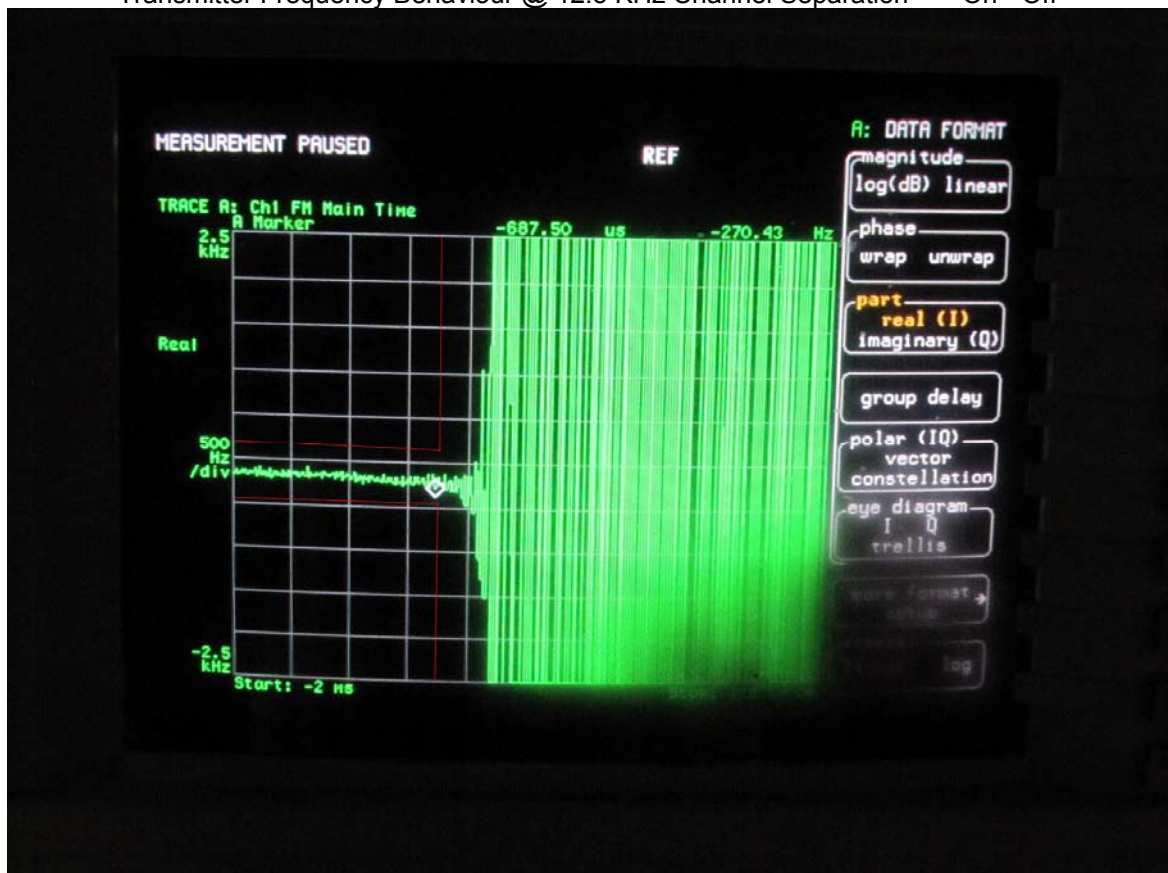

4.9. Receiver Radiated Spurious Emission

TEST APPLICABLE

The field strength is calculated by adding the Antenna Factor and Cable Factor and subtracting the Amplifier Gain and Duty Cycle Correction Factor (if any) from the measured reading. The basic equation with a sample calculation is as follows:

$$FS = RA + AF + CL - AG$$

Where FS = Field Strength	CL = Cable Attenuation Factor (Cable Loss)
RA = Reading Amplitude	AG = Amplifier Gain
AF = Antenna Factor	

TEST CONFIGURATION

(A) Radiated Emission Test Set-Up, Frequency below 1000MHz

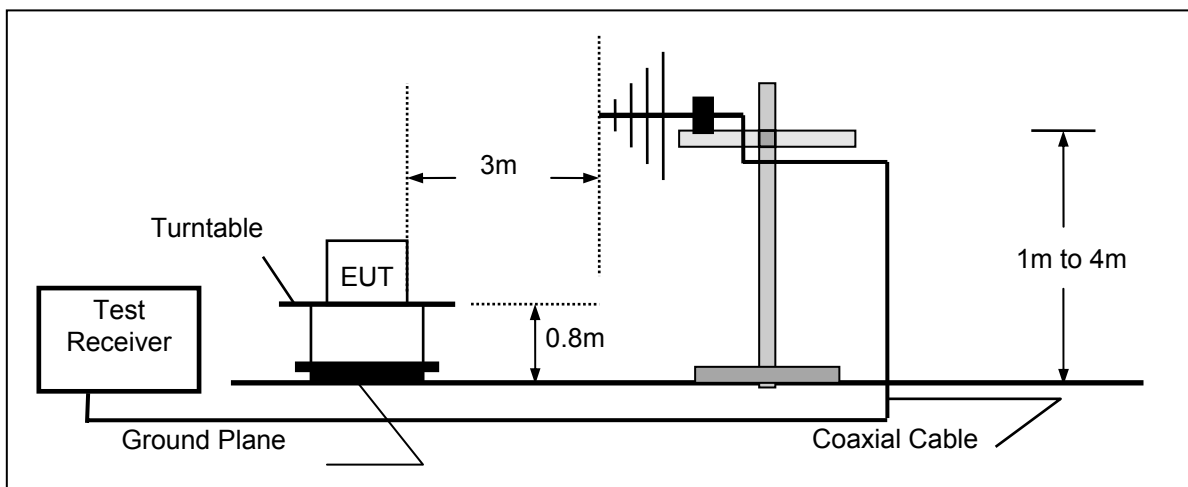

(B) Radiated Emission Test Set-Up, Frequency above 1000MHz

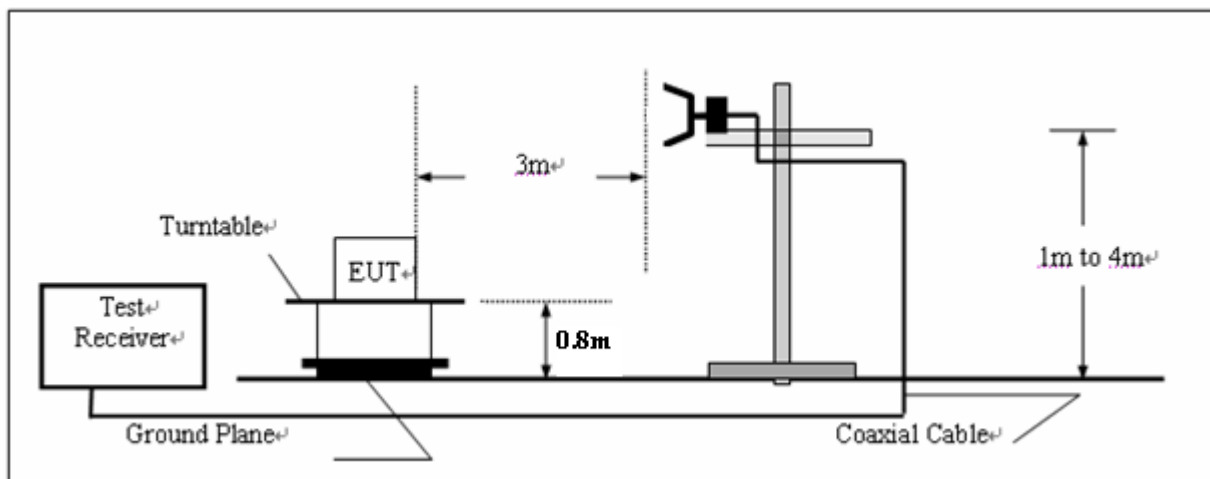

TEST PROCEDURE

- 1 The EUT was placed on a turn table which is 0.8m above ground plane.
- 2 Maximum procedure was performed by raising the receiving antenna from 1m to 4m and rotating the turn table from 0° to 360° to acquire the highest emissions from EUT
- 3 And also, each emission was to be maximized by changing the polarization of receiving antenna both horizontal and vertical.
- 4 Repeat above procedures until all frequency measurements have been completed.

RECEIVER RADIATED SPOUIOUS LIMIT

For unintentional device, according to § 15.109(a) and RSS-Gen, except for Class A digital devices, the field strength of radiated emissions from unintentional radiators at a distance of 3 meters shall not exceed the following values:

Frequency (MHz)	Distance (Meters)	Radiated (dB μ V/m)	Radiated (μ V/m)
30-88	3	40.0	100
88-216	3	43.5	150
216-960	3	46.0	200
Above 960	3	54.0	500

For intentional device, according to § 15.209(a), the general requirement of field strength of radiated emissions from intentional radiators at a distance of 3 meters shall not exceed the above table.

TEST RESULTS

The Radiated Measurement are performed to the five channels (the top channel, the middle channel and the bottom channel), the datum recorded below is the worst case for each channel separation;and the EUT shall be scanned from 30 MHz to the 5th harmonic of the highest oscillator frequency in the digital devices or 1 GHz whichever is higher.

Modulation Type	Channel Separation	Test Frequency (MHz)	Polar.	Maximum Radiated Emissions		FCC Limit (dBuV/m)
				Frequency (MHz)	Datum (dBuV/m)	
FM	12.5 KHz	406.5000	H	187.14	31.20	43.50
			V	144.46	31.50	43.50
Test Results			Compliance			

SWEEP TABLE: "test (30M-1G)"

```

Short Description:           Field Strength
Start      Stop      Detector Meas.   IF      Transducer
Frequency  Frequency Time      Bandw.
30.0 MHz   1.0 GHz   MaxPeak Coupled  100 kHz HL562 201106
    
```

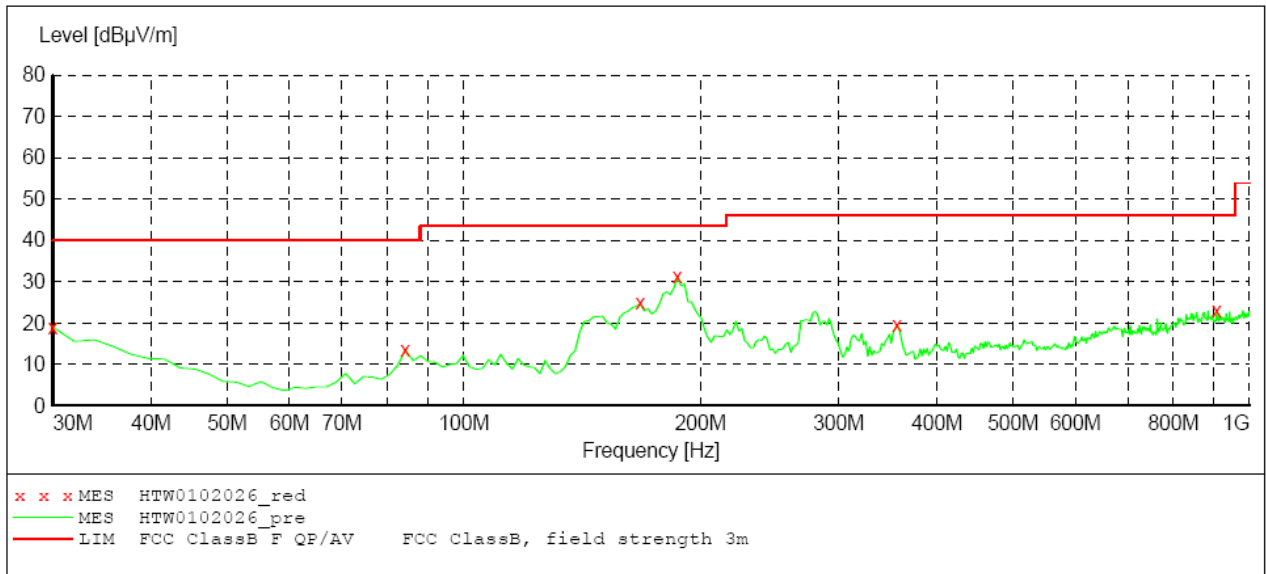

MEASUREMENT RESULT: "HTW0102026_red"

1/2/2013 1:09PM

Frequency MHz	Level dBuV/m	Transd dB	Limit dBuV/m	Margin dB	Det.	Height cm	Azimuth deg	Polarization
30.000000	19.00	-11.1	40.0	21.0	PK	100.0	197.00	HORIZONTAL
84.320000	13.50	-21.3	40.0	26.5	PK	100.0	228.00	HORIZONTAL
167.740000	24.80	-23.4	43.5	18.7	PK	100.0	126.00	HORIZONTAL
187.140000	31.20	-22.4	43.5	12.3	PK	100.0	138.00	HORIZONTAL
355.920000	19.40	-17.0	46.0	26.6	PK	100.0	305.00	HORIZONTAL
908.820000	23.00	-7.3	46.0	23.0	PK	100.0	340.00	HORIZONTAL

SWEEP TABLE: "test (30M-1G)"

Short Description:		Field Strength			
Start	Stop	Detector	Meas. Time	IF Bandw.	Transducer
Frequency 30.0 MHz	Frequency 1.0 GHz	MaxPeak	Coupled	100 kHz	HL562 201106

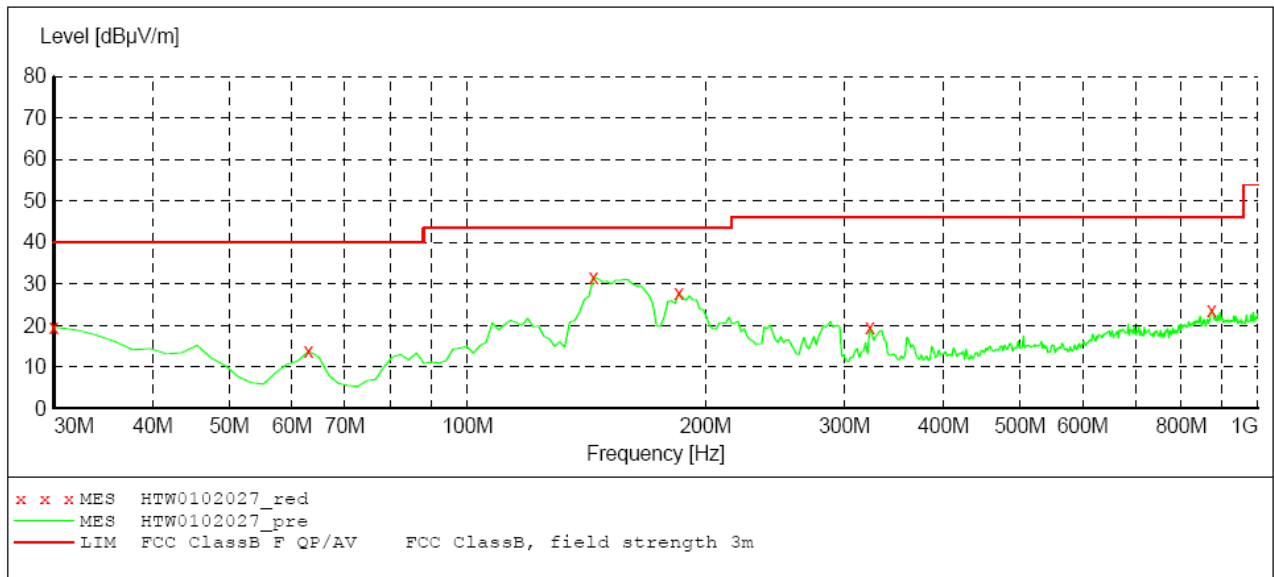

MEASUREMENT RESULT: "HTW0102027_red"

1/2/2013 1:11PM

Frequency MHz	Level dBµV/m	Transd dB	Limit dBµV/m	Margin dB	Det.	Height cm	Azimuth deg	Polarization
30.000000	19.60	-11.1	40.0	20.4	PK	100.0	78.00	VERTICAL
62.980000	13.80	-24.3	40.0	26.2	PK	100.0	354.00	VERTICAL
144.460000	31.50	-22.3	43.5	12.0	PK	100.0	63.00	VERTICAL
185.200000	27.80	-22.3	43.5	15.7	PK	100.0	242.00	VERTICAL
322.940000	19.40	-16.4	46.0	26.6	PK	100.0	182.00	VERTICAL
873.900000	23.70	-7.0	46.0	22.3	PK	100.0	284.00	VERTICAL

Modulation Type	Channel Separation	Test Frequency (MHz)	Polar.	Maximum Radiated Emissions		FCC Limit (dBuV/m)
				Frequency (MHz)	Datum (dBuV/m)	
FM	12.5 KHz	406.5000	H	5248.49	46.80	54.00
			V	5448.89	46.30	54.00
Test Results			Compliance			

SWEEP TABLE: "test (1G-18G) P"

Short Description: Field Strength
 Start Stop Detector Meas. IF Transducer
 Frequency Frequency Time Bandw.
 1.0 GHz 18.0 GHz MaxPeak 500.0 ms 1 MHz HF906

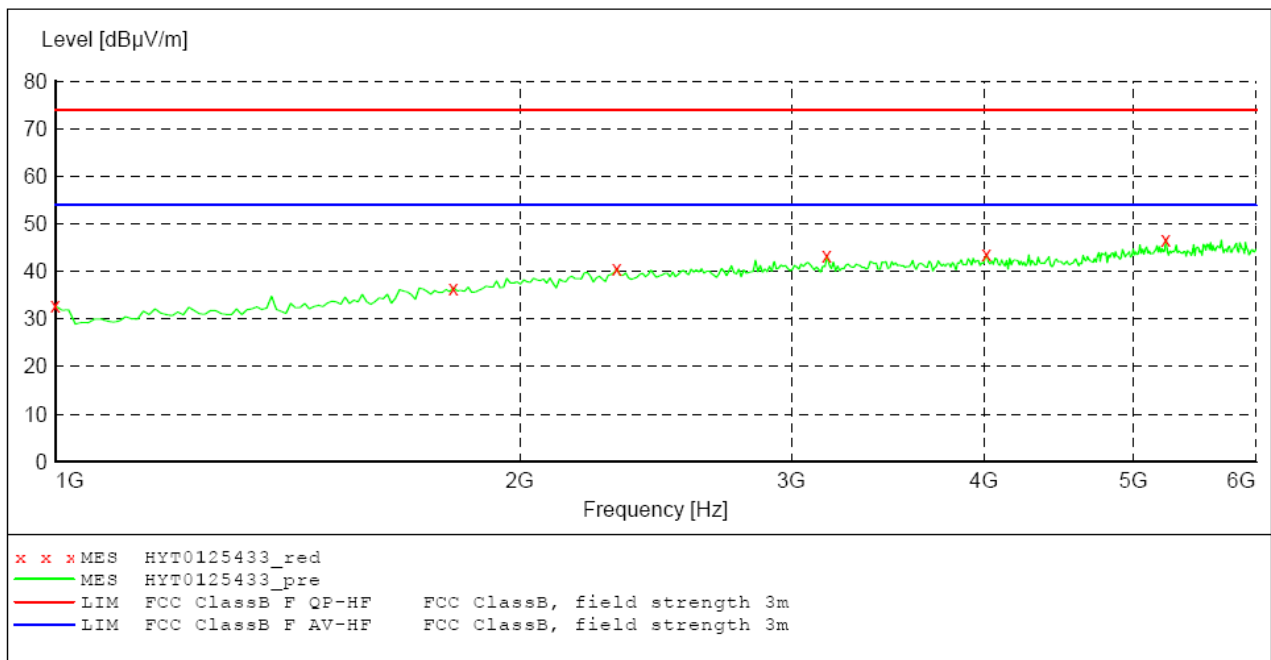

MEASUREMENT RESULT: "HYT0125433_red"

1/25/2013 10:39PM

Frequency MHz	Level dBuV/m	Transd dB	Limit dBuV/m	Margin dB	Det.	Height cm	Azimuth deg	Polarization
1000.000000	32.80	-9.8	74.0	41.2	PK	100.0	301.00	HORIZONTAL
1811.623246	36.60	-3.0	74.0	37.4	PK	100.0	160.00	HORIZONTAL
2312.625251	40.70	0.1	74.0	33.3	PK	100.0	187.00	HORIZONTAL
3164.328657	43.40	2.3	74.0	30.6	PK	100.0	90.00	HORIZONTAL
4016.032064	43.60	3.6	74.0	30.4	PK	100.0	284.00	HORIZONTAL
5248.496994	46.80	6.1	74.0	27.2	PK	100.0	301.00	HORIZONTAL

SWEEP TABLE: "test (1G-18G) P"

Short Description:		Field Strength			
Start	Stop	Detector	Meas. Time	IF Bandw.	Transducer
Frequency 1.0 GHz	Frequency 18.0 GHz	MaxPeak	500.0 ms	1 MHz	HF906

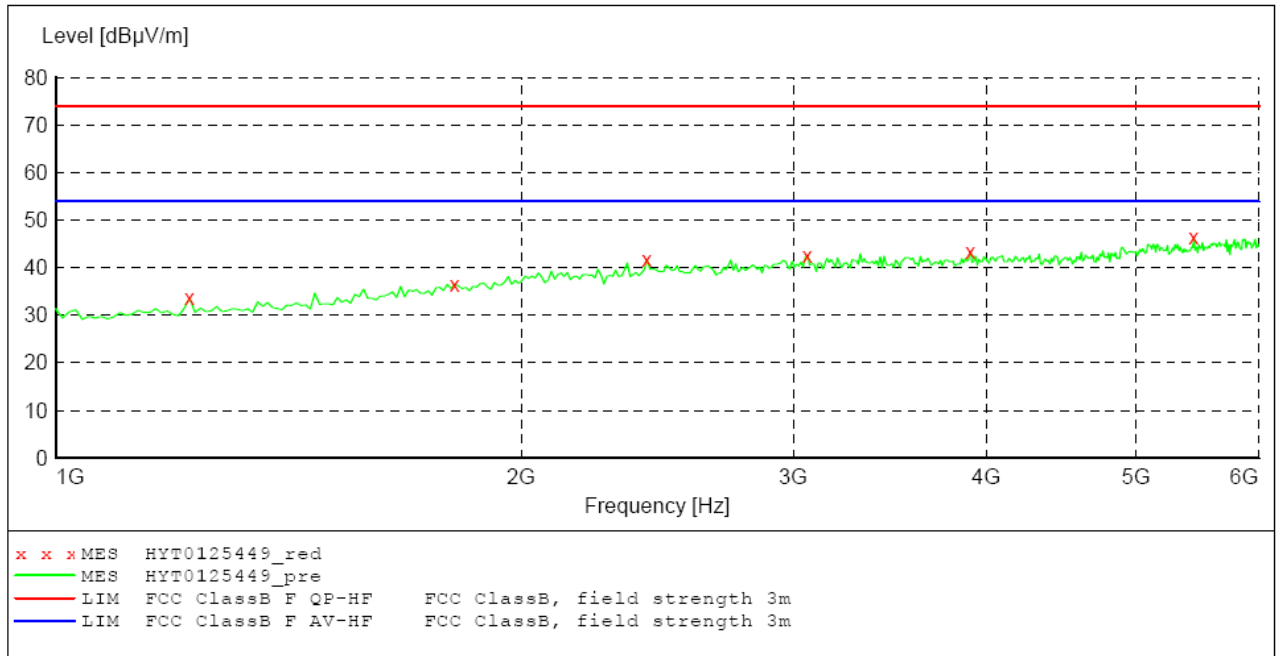

MEASUREMENT RESULT: "HYT0125449_red"

1/25/2013 11:09PM

Frequency MHz	Level dBµV/m	Transd dB	Limit dBµV/m	Margin dB	Det.	Height cm	Azimuth deg	Polarization
1220.440882	33.70	-7.9	74.0	40.3	PK	100.0	36.00	VERTICAL
1811.623246	36.60	-3.0	74.0	37.4	PK	100.0	184.00	VERTICAL
2412.825651	41.80	0.5	74.0	32.2	PK	100.0	93.00	VERTICAL
3064.128257	42.70	2.2	74.0	31.3	PK	100.0	113.00	VERTICAL
3905.811623	43.30	3.4	74.0	30.7	PK	100.0	79.00	VERTICAL
5448.897796	46.30	6.5	74.0	27.7	PK	100.0	33.00	VERTICAL

Modulation Type	Channel Separation	Test Frequency (MHz)	Polar.	Maximum Radiated Emissions		FCC Limit (dBuV/m)
				Frequency (MHz)	Datum (dBuV/m)	
4FSK	12.5 KHz	406.5000	H	146.40	31.50	43.50
			V	148.34	28.20	43.50
Test Results			Compliance			

SWEEP TABLE: "test (30M-1G)"

Short Description:		Field Strength			
Start	Stop	Detector	Meas.	IF	Transducer
Frequency	Frequency		Time	Bandw.	
30.0 MHz	1.0 GHz	MaxPeak	Coupled	120 kHz	HL562 201106

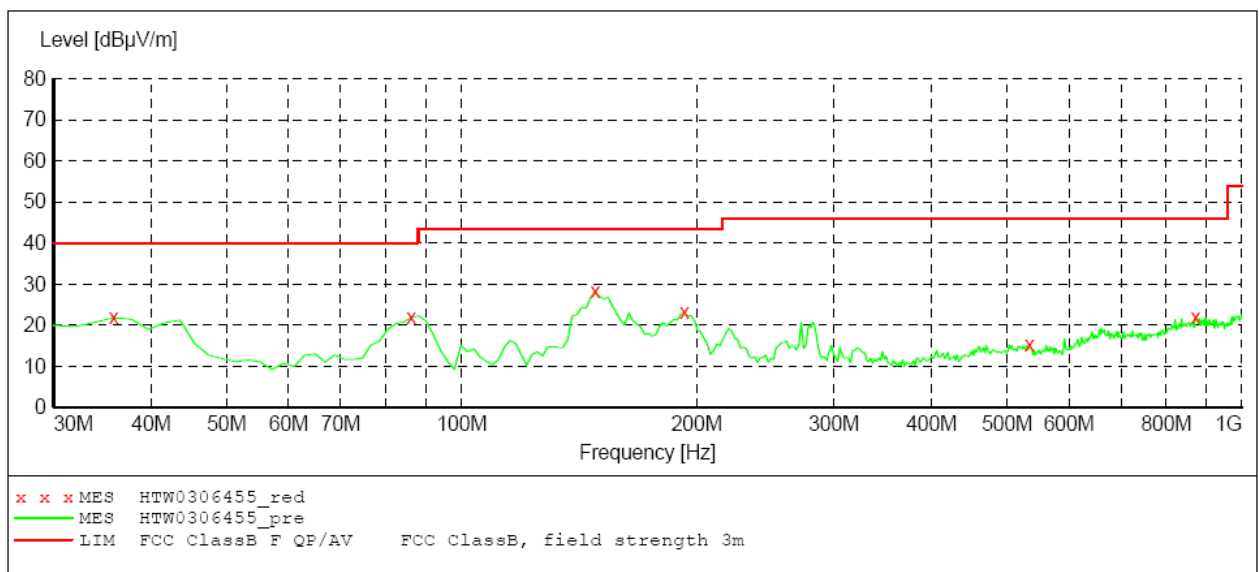

MEASUREMENT RESULT: "HTW0306455_red"

3/6/2013 3:11PM

Frequency MHz	Level dBuV/m	Transd dB	Limit dBuV/m	Margin dB	Det.	Height cm	Azimuth deg	Polarization
35.820000	21.80	-14.0	40.0	18.2	PK	100.0	137.00	VERTICAL
86.260000	21.80	-20.9	40.0	18.2	PK	100.0	311.00	VERTICAL
148.340000	28.20	-22.6	43.5	15.3	PK	100.0	229.00	VERTICAL
192.960000	23.10	-22.1	43.5	20.4	PK	100.0	241.00	VERTICAL
534.400000	15.30	-13.4	46.0	30.7	PK	100.0	125.00	VERTICAL
871.960000	22.10	-6.9	46.0	23.9	PK	100.0	137.00	VERTICAL

SWEEP TABLE: "test (30M-1G)"

Short Description:		Field Strength			
Start	Stop	Detector	Meas. Time	IF Bandw.	Transducer
Frequency	Frequency				
30.0 MHz	1.0 GHz	MaxPeak	Coupled	120 kHz	HL562 201106

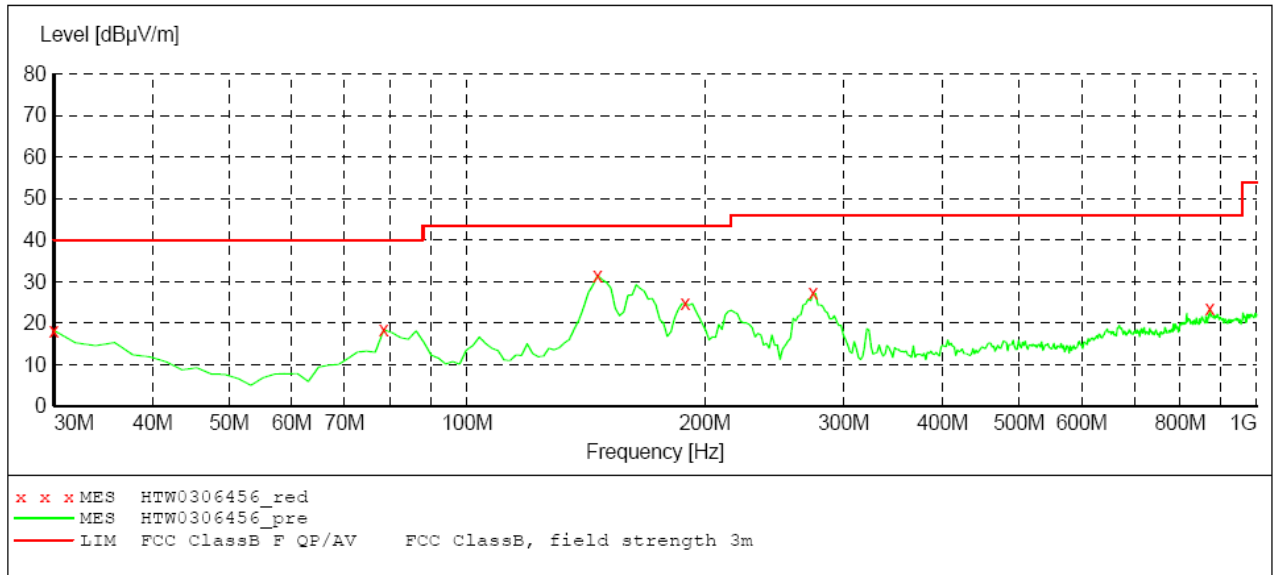

MEASUREMENT RESULT: "HTW0306456_red"

3/6/2013 3:13PM

Frequency MHz	Level dBµV/m	Transd dB	Limit dBµV/m	Margin dB	Det.	Height cm	Azimuth deg	Polarization
30.000000	18.20	-11.1	40.0	21.8	PK	100.0	315.00	HORIZONTAL
78.500000	18.40	-22.4	40.0	21.6	PK	300.0	185.00	HORIZONTAL
146.400000	31.50	-22.5	43.5	12.0	PK	300.0	166.00	HORIZONTAL
189.080000	24.70	-22.5	43.5	18.8	PK	100.0	135.00	HORIZONTAL
274.440000	27.20	-18.1	46.0	18.8	PK	100.0	320.00	HORIZONTAL
871.960000	23.60	-6.9	46.0	22.4	PK	100.0	54.00	HORIZONTAL

Modulation Type	Channel Separation	Test Frequency (MHz)	Polar.	Maximum Radiated Emissions		FCC Limit (dBuV/m)
				Frequency (MHz)	Datum (dBuV/m)	
4FSK	12.5 KHz	406.5000	H	5989.97	46.40	54.00
			V	5569.13	45.80	54.00
Test Results			Compliance			

SWEEP TABLE: "test (1G-18G) P"

Short Description: Field Strength
 Start Stop Detector Meas. IF Transducer
 Frequency Frequency Time Bandw.
 1.0 GHz 18.0 GHz MaxPeak 500.0 ms 1 MHz HF906

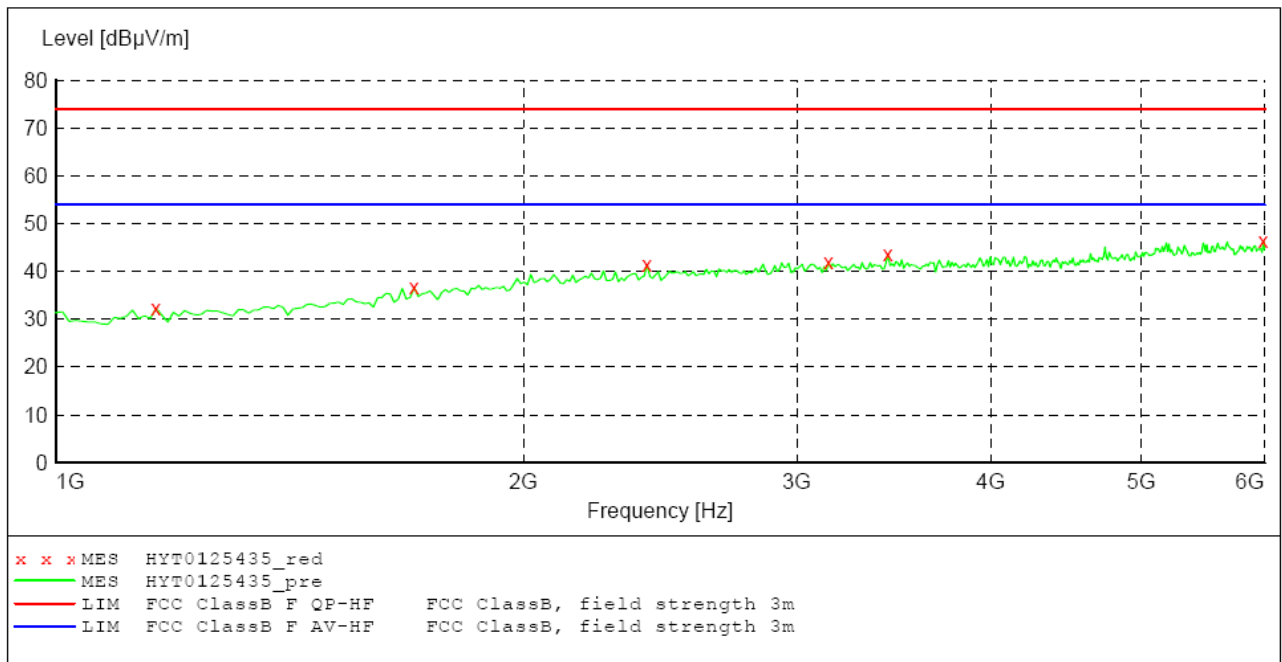

MEASUREMENT RESULT: "HYT0125435_red"

1/25/2013 10:44PM

Frequency MHz	Level dBuV/m	Transd dB	Limit dBuV/m	Margin dB	Det.	Height cm	Azimuth deg	Polarization
1160.320641	32.30	-8.4	74.0	41.7	PK	100.0	325.00	HORIZONTAL
1701.402806	36.70	-3.9	74.0	37.3	PK	100.0	356.00	HORIZONTAL
2402.805611	41.40	0.5	74.0	32.6	PK	100.0	343.00	HORIZONTAL
3144.288577	42.00	2.3	74.0	32.0	PK	100.0	107.00	HORIZONTAL
3434.869739	43.70	2.6	74.0	30.3	PK	100.0	241.00	HORIZONTAL
5989.979960	46.40	7.3	74.0	27.6	PK	100.0	271.00	HORIZONTAL

SWEEP TABLE: "test (1G-18G) P"

Short Description:		Field Strength			
Start	Stop	Detector	Meas. Time	IF Bandw.	Transducer
Frequency	Frequency	MaxPeak			
1.0 GHz	18.0 GHz		500.0 ms	1 MHz	HF906

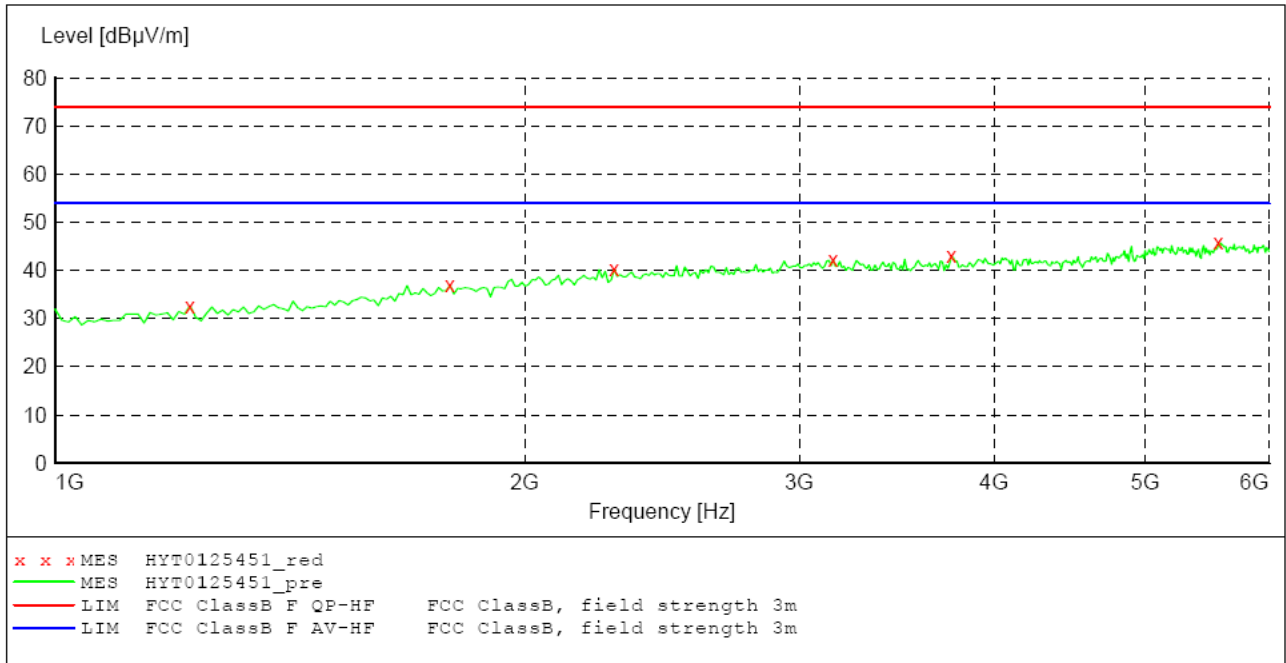

MEASUREMENT RESULT: "HYT0125451_red"

1/25/2013 11:13PM

Frequency MHz	Level dBµV/m	Transd dB	Limit dBµV/m	Margin dB	Det.	Height cm	Azimuth deg	Polarization
1220.440882	32.70	-7.9	74.0	41.3	PK	100.0	187.00	VERTICAL
1791.583166	37.00	-3.1	74.0	37.0	PK	100.0	119.00	VERTICAL
2282.565130	40.30	0.0	74.0	33.7	PK	100.0	288.00	VERTICAL
3154.308617	42.20	2.3	74.0	31.8	PK	100.0	130.00	VERTICAL
3755.511022	43.00	3.1	74.0	31.0	PK	100.0	53.00	VERTICAL
5569.138277	45.80	6.7	74.0	28.2	PK	100.0	354.00	VERTICAL

4.10. Receiver Conducted Spurious Emission

TEST APPLICABLE

The same as Section 4.3

TEST PROCEDURE

The spectrum analyzer was connected to the RF output power of the EUT, the EUT was setup in receiving mode; The RBW of the spectrum analyzer was set to 100 kHz and the VBW set to 300 KHz below the test frequency 1GHz. While the RBW of the spectrum analyzer was set to the 1MHz and VBW set to the 3MHz from 1GHz to the 10th harmonic.

TEST CONFIGURATION

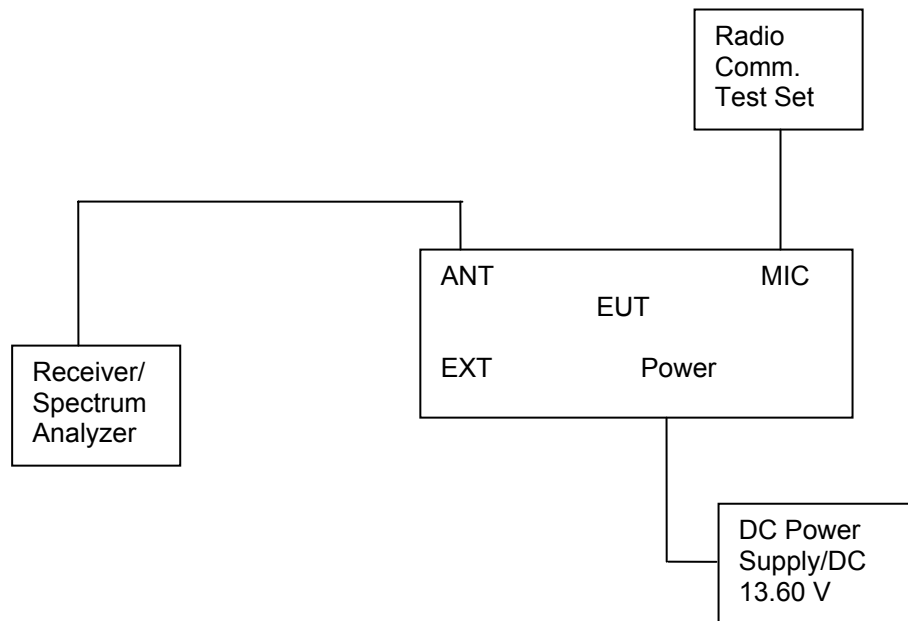

LIMIT

The power at the antenna terminal shall not exceed 2.0 nanowatts (-57dBm).

TEST RESULTS

The Receiver Conducted Spurious Emissions Measurement is performed to the five channels (the top channel, the middle channel and the bottom channel), the datums recorded below were for the five channels; and the EUT shall be scanned from 30 MHz to the 5 GHz.

Modulation Type	Channel SpARATION	Test Channel	Test Frequency (MHz)	Maximum Conducted Spurious Emissions Below 1GHz		Maximum Conducted Spurious Emissions Above 1GHz		FCC Limit
				Frequency (MHz)	Datum (dBm)	Frequency (MHz)	Datum (dBm)	
FM	12.5KHz	Low	406.5000	835.10	-78.69	3144.00	-75.93	-57dBm
Test Results				Compliance				

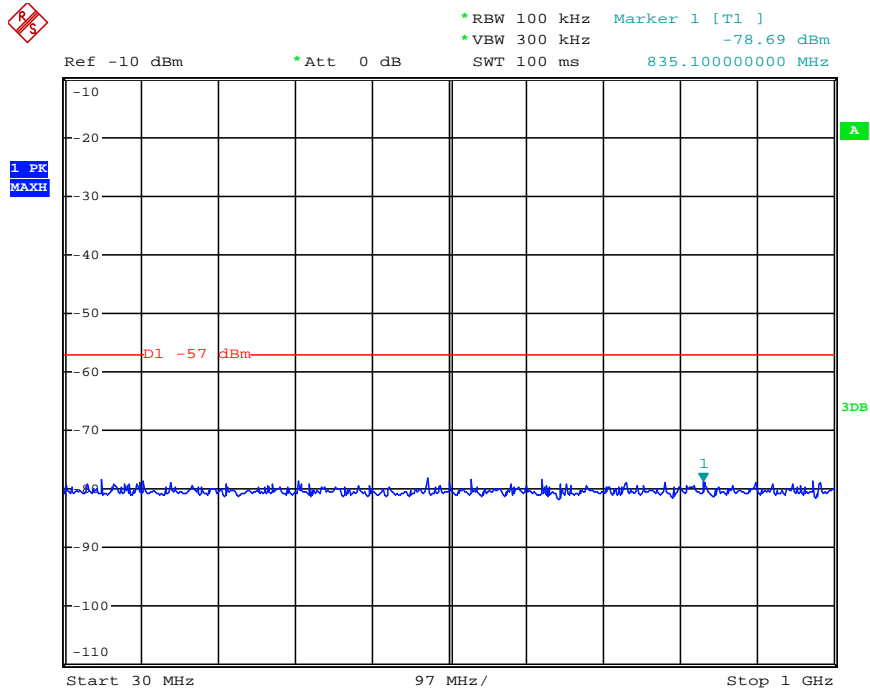

Date: 21.JAN.2013 15:05:54

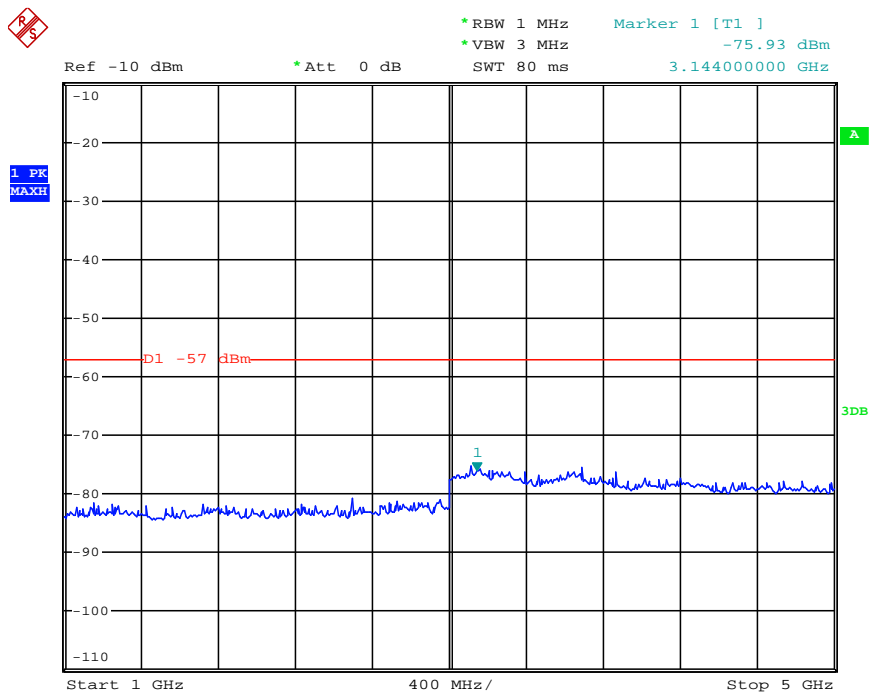

Date: 21.JAN.2013 15:10:06

Modulation Type	Channel SpARATION	Test Channel	Test Frequency (MHz)	Maximum Conducted Spurious Emissions Below 1GHz		Maximum Conducted Spurious Emissions Above 1GHz		FCC Limit
				Frequency (MHz)	Datum (dBm)	Frequency (MHz)	Datum (dBm)	
FM	12.5KHz	Low	418.0000	602.30	-79.47	3664.00	-76.01	-57dBm
Test Results				Compliance				

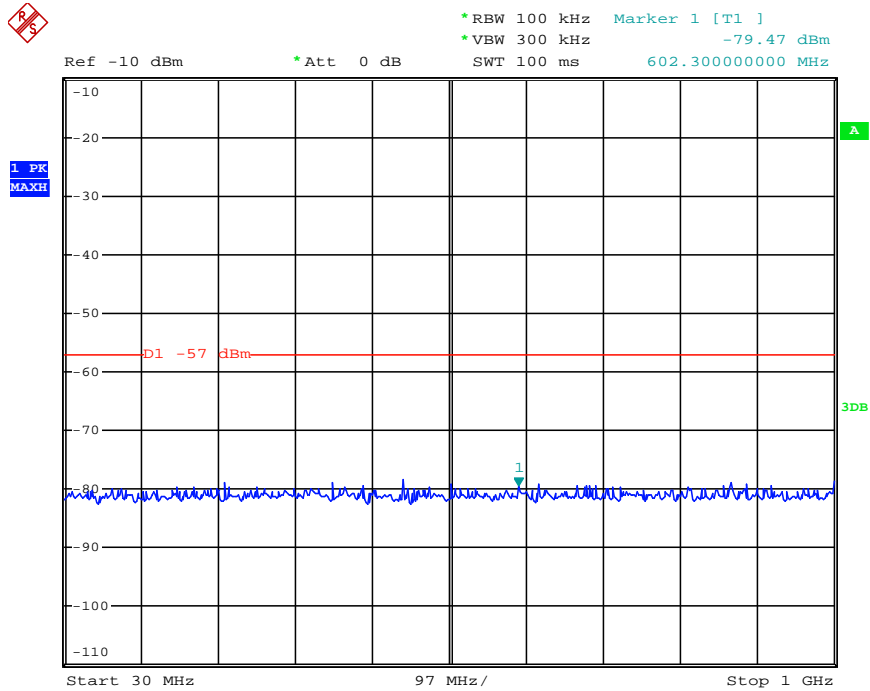

Date: 21.JAN.2013 15:06:06

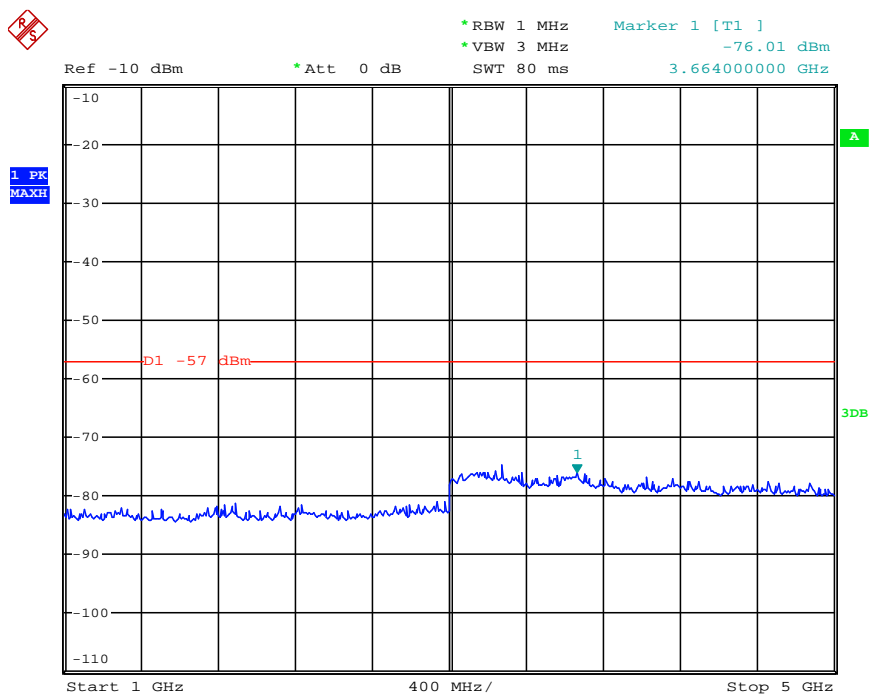

Date: 21.JAN.2013 15:10:20

Modulation Type	Channel SpARATION	Test Channel	Test Frequency (MHz)	Maximum Conducted Spurious Emissions Below 1GHz		Maximum Conducted Spurious Emissions Above 1GHz		FCC Limit
				Frequency (MHz)	Datum (dBm)	Frequency (MHz)	Datum (dBm)	
FM	12.5KHz	Middle	435.5000	95.96	-77.67	3168.00	-75.06	-57dBm
Test Results				Compliance				

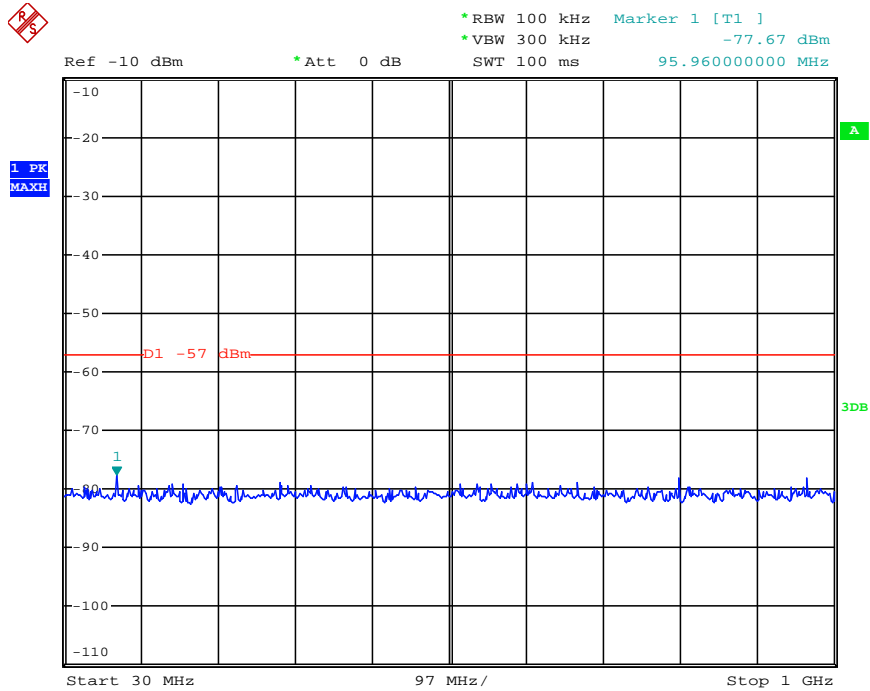

Date: 21.JAN.2013 15:06:19

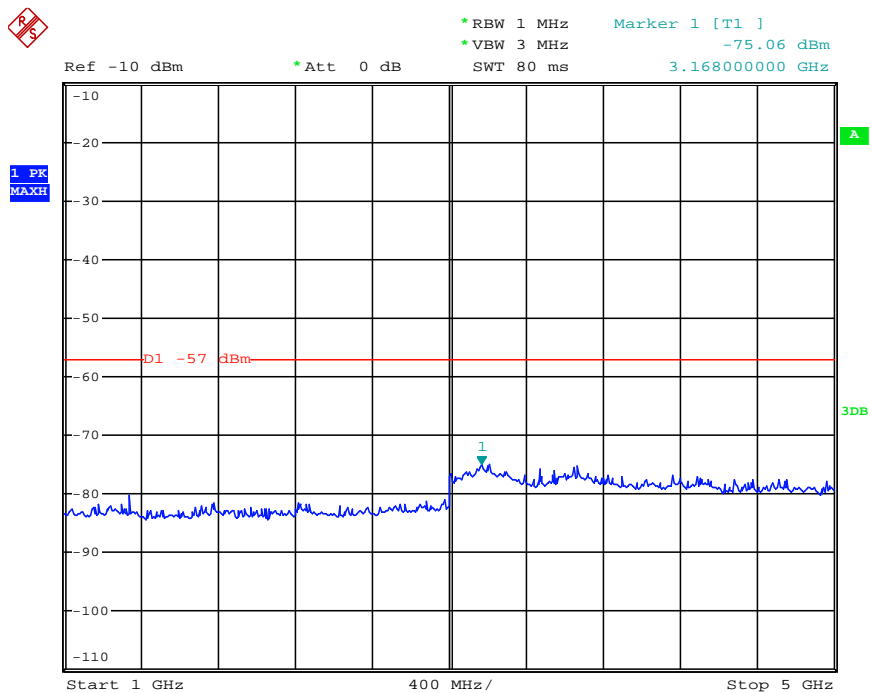

Date: 21.JAN.2013 15:10:34

Modulation Type	Channel SpARATION	Test Channel	Test Frequency (MHz)	Maximum Conducted Spurious Emissions Below 1GHz		Maximum Conducted Spurious Emissions Above 1GHz		FCC Limit
				Frequency (MHz)	Datum (dBm)	Frequency (MHz)	Datum (dBm)	
FM	12.5KHz	High	453.0000	730.34	-78.43	3224.00	-75.58	-57dBm
Test Results				Compliance				

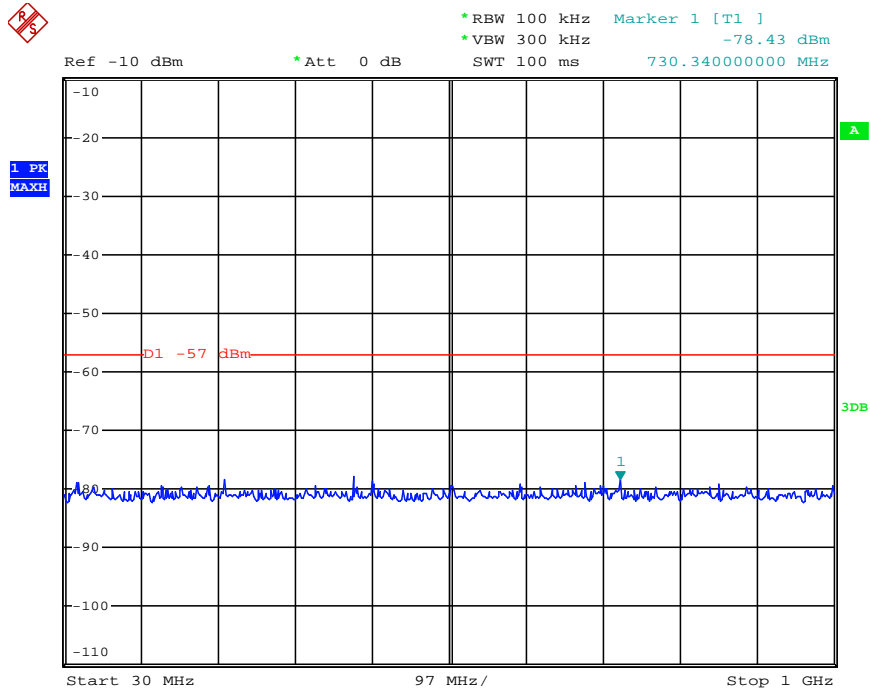

Date: 21.JAN.2013 15:06:32

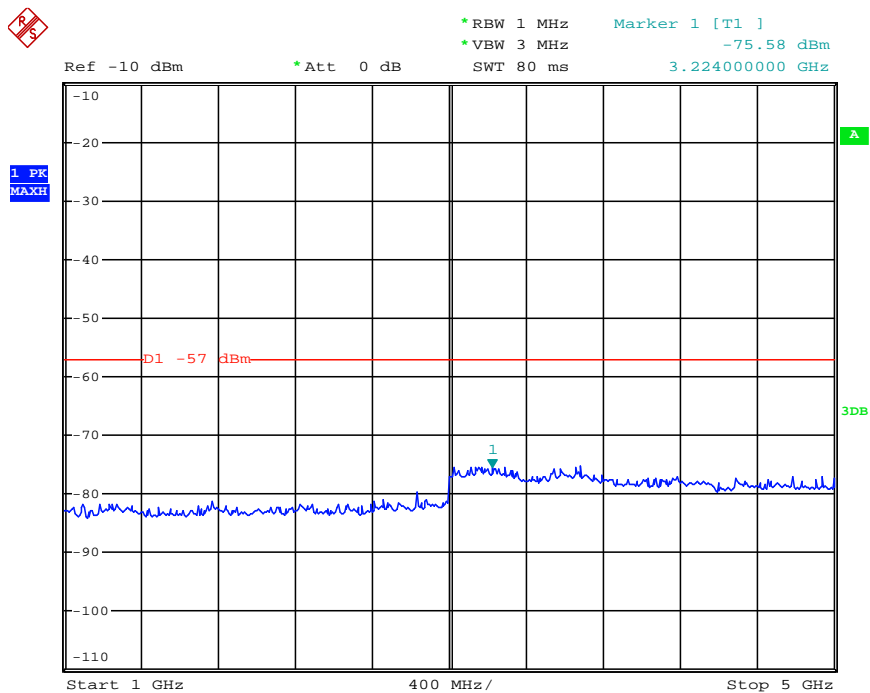

Date: 21.JAN.2013 15:11:02

Modulation Type	Channel SpARATION	Test Channel	Test Frequency (MHz)	Maximum Conducted Spurious Emissions Below 1GHz		Maximum Conducted Spurious Emissions Above 1GHz		FCC Limit
				Frequency (MHz)	Datum (dBm)	Frequency (MHz)	Datum (dBm)	
FM	12.5KHz	High	469.5000	837.04	-79.26	3248.00	-74.98	-57dBm
Test Results				Compliance				

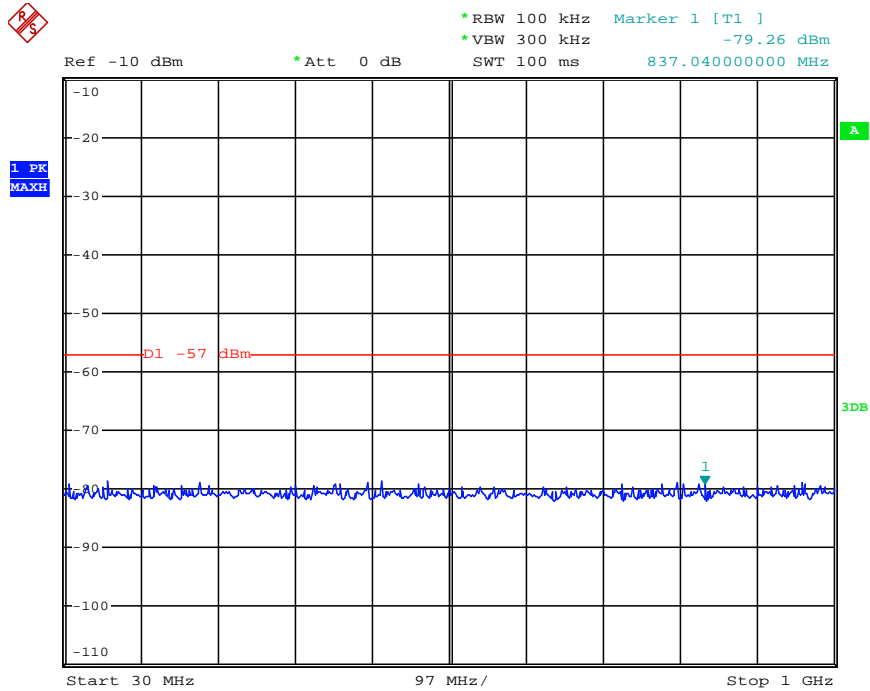

Date: 21.JAN.2013 15:06:48

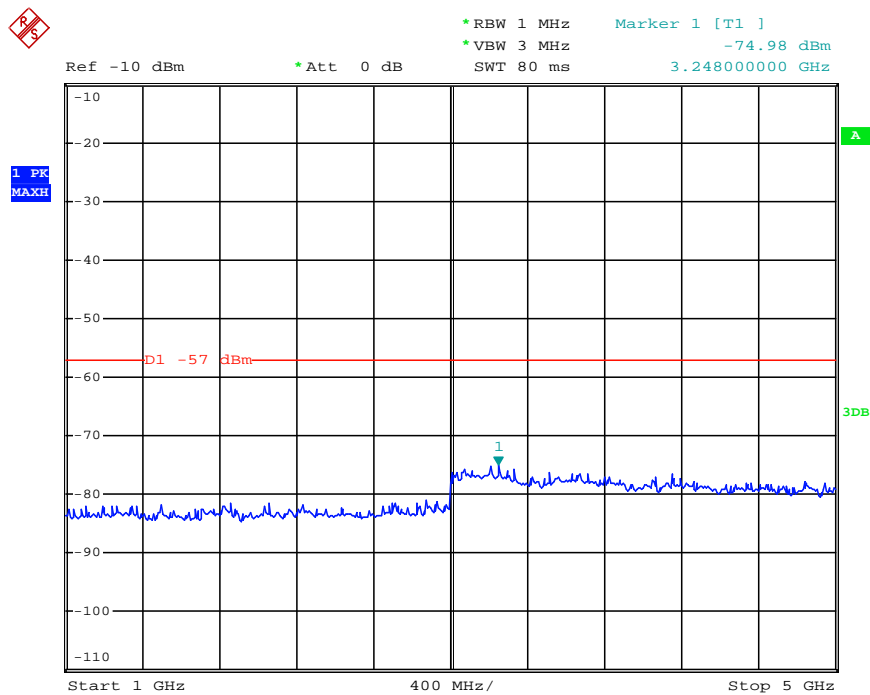

Date: 21.JAN.2013 15:11:14

Modulation Type	Channel SpARATION	Test Channel	Test Frequency (MHz)	Maximum Conducted Spurious Emissions Below 1GHz		Maximum Conducted Spurious Emissions Above 1GHz		FCC Limit
				Frequency (MHz)	Datum (dBm)	Frequency (MHz)	Datum (dBm)	
4FSK	12.5KHz	Low	406.5000	891.36	-79.19	3104.00	-75.81	-57dBm
Test Results				Compliance				

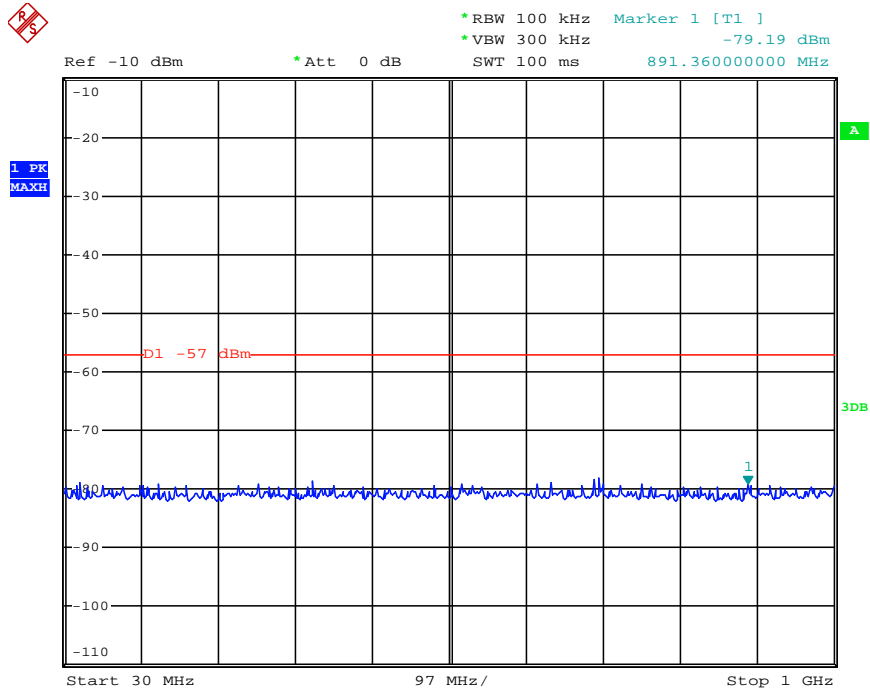

Date: 21.JAN.2013 15:07:19

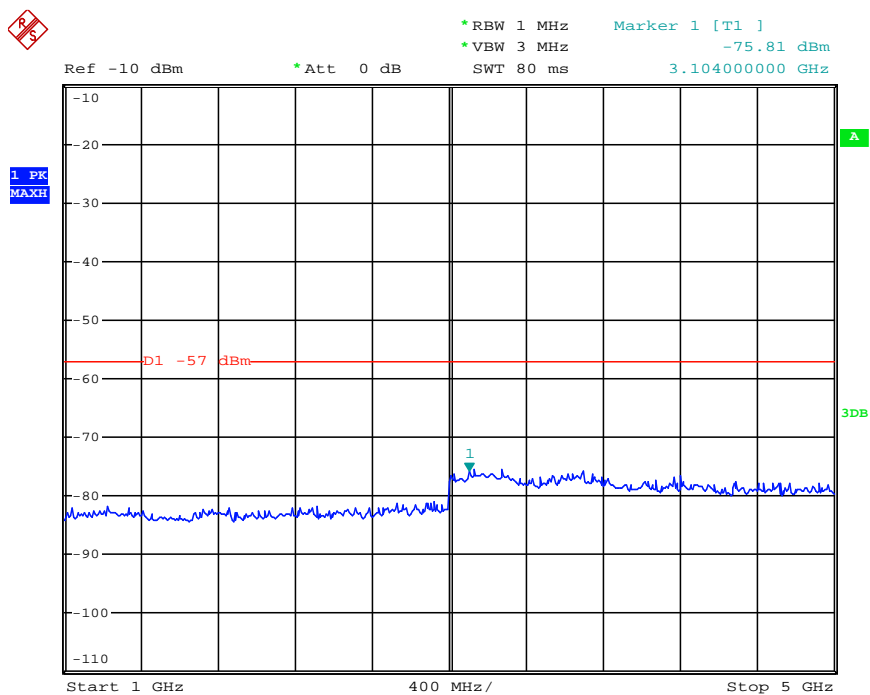

Date: 21.JAN.2013 15:13:26

Modulation Type	Channel Sparation	Test Channel	Test Frequency (MHz)	Maximum Conducted Spurious Emissions Below 1GHz		Maximum Conducted Spurious Emissions Above 1GHz		FCC Limit
				Frequency (MHz)	Datum (dBm)	Frequency (MHz)	Datum (dBm)	
4FSK	12.5KHz	Low	418.0000	726.46	-78.64	3168.00	-75.86	-57dBm
Test Results				Compliance				

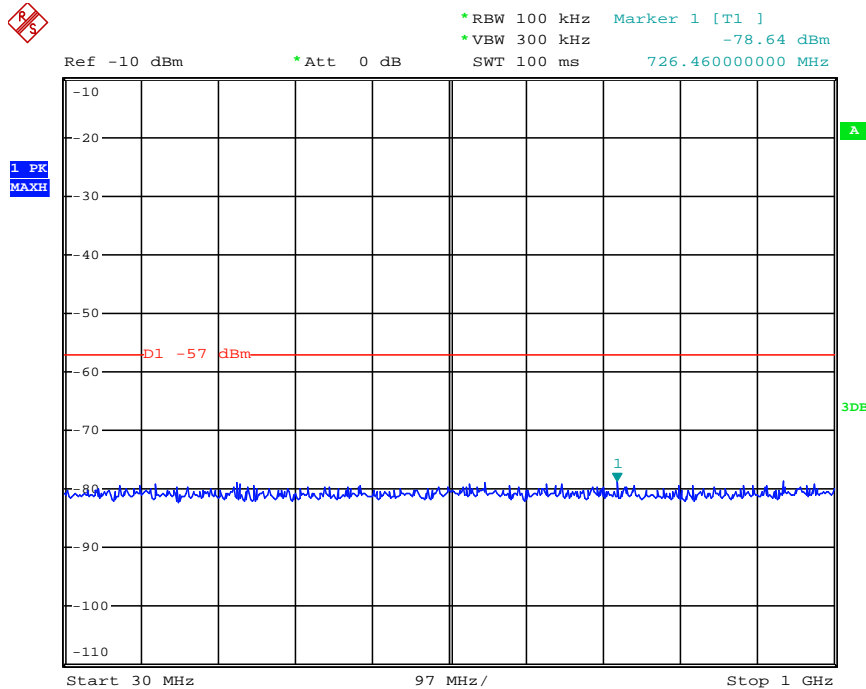

Date: 21.JAN.2013 15:07:34

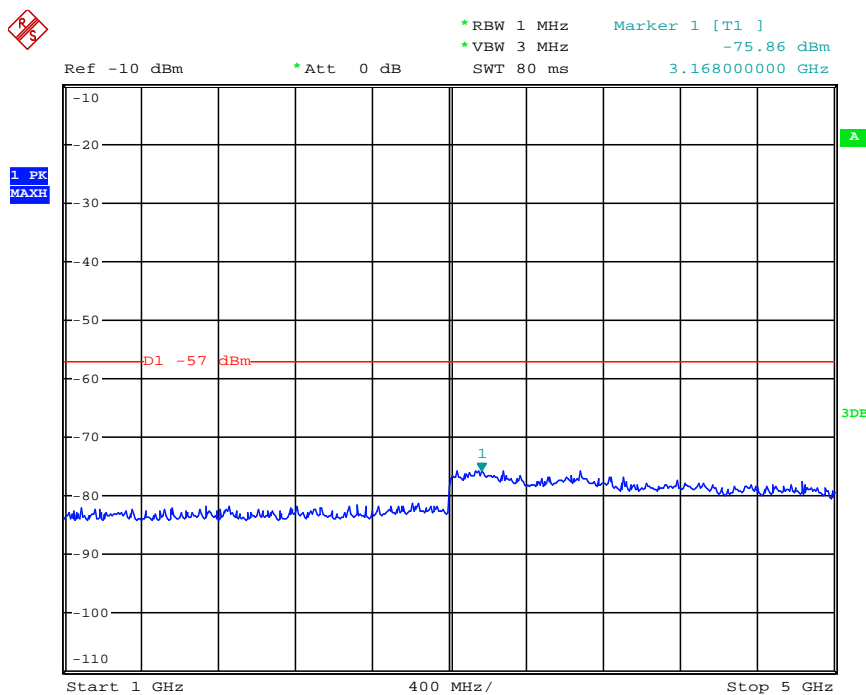

Date: 21.JAN.2013 15:13:38

Modulation Type	Channel SpARATION	Test Channel	Test Frequency (MHz)	Maximum Conducted Spurious Emissions Below 1GHz		Maximum Conducted Spurious Emissions Above 1GHz		FCC Limit
				Frequency (MHz)	Datum (dBm)	Frequency (MHz)	Datum (dBm)	
4FSK	12.5KHz	Middle	435.5000	55.22	-78.83	3800.00	-75.24	-57dBm
Test Results				Compliance				

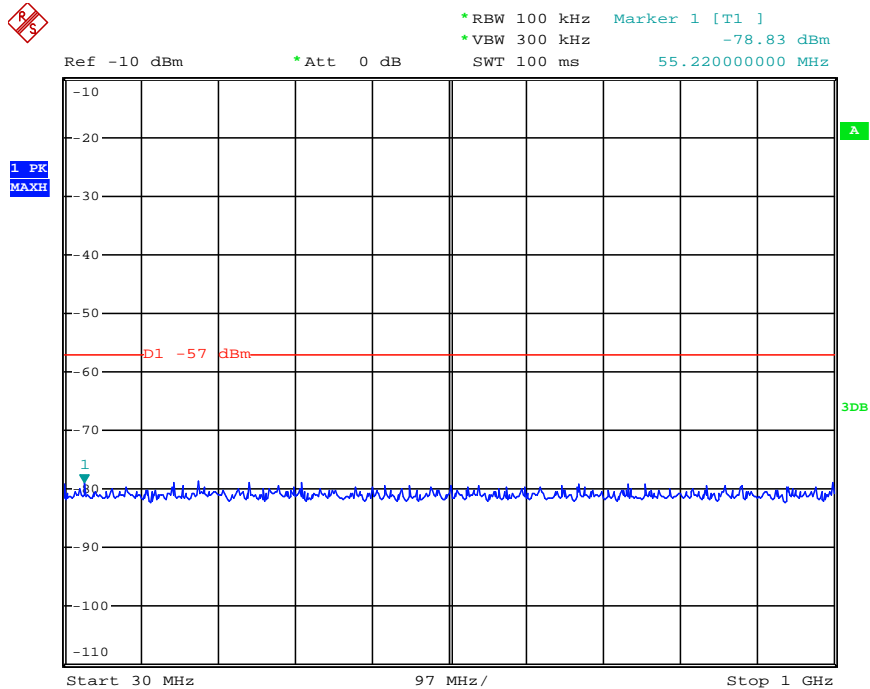

Date: 21.JAN.2013 15:07:47

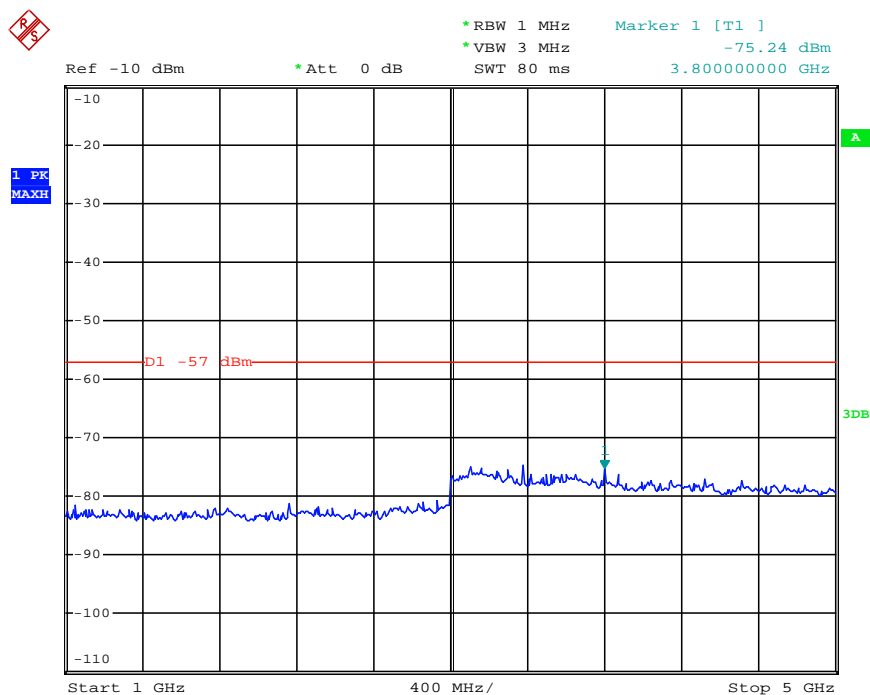

Date: 21.JAN.2013 15:13:53

Modulation Type	Channel SpARATION	Test Channel	Test Frequency (MHz)	Maximum Conducted Spurious Emissions Below 1GHz		Maximum Conducted Spurious Emissions Above 1GHz		FCC Limit
				Frequency (MHz)	Datum (dBm)	Frequency (MHz)	Datum (dBm)	
4FSK	12.5KHz	High	469.5000	165.80	-78.57	3288.00	-75.73	-57dBm
Test Results				Compliance				

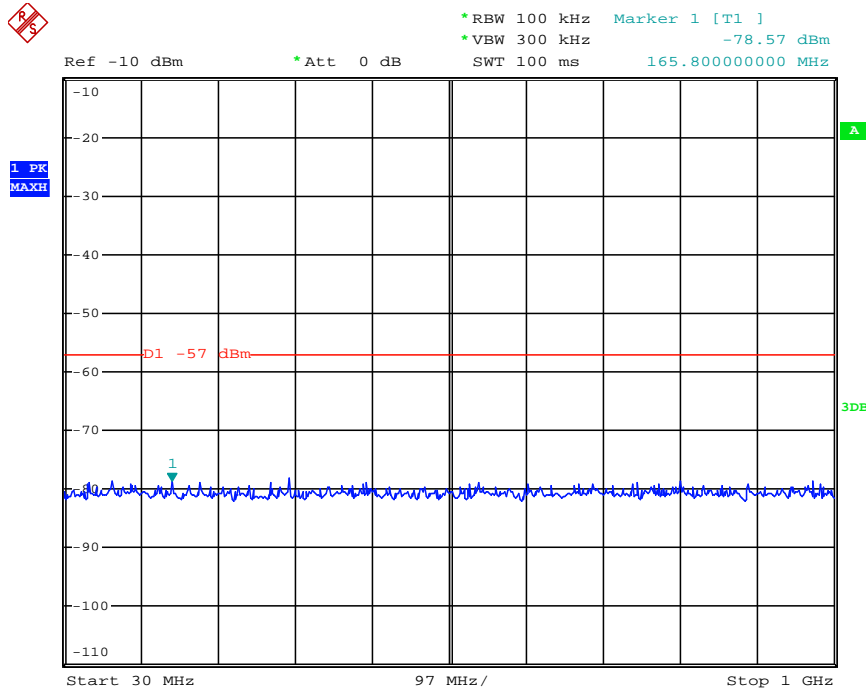

Date: 21.JAN.2013 15:08:21

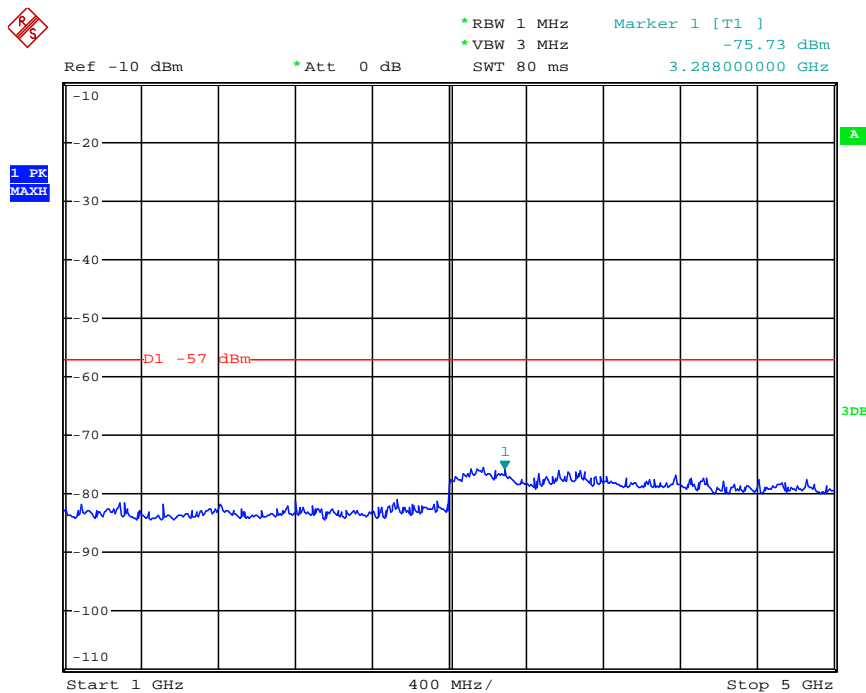

Date: 21.JAN.2013 15:14:17

5. Test Setup Photos of the EUT

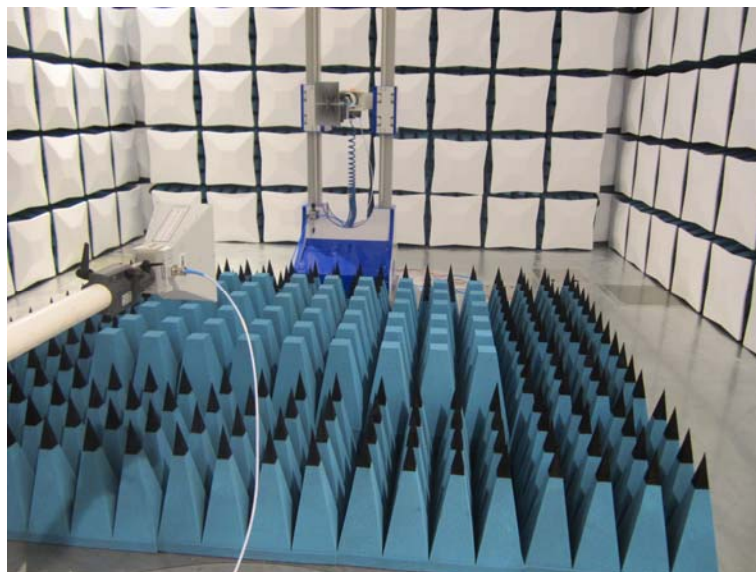







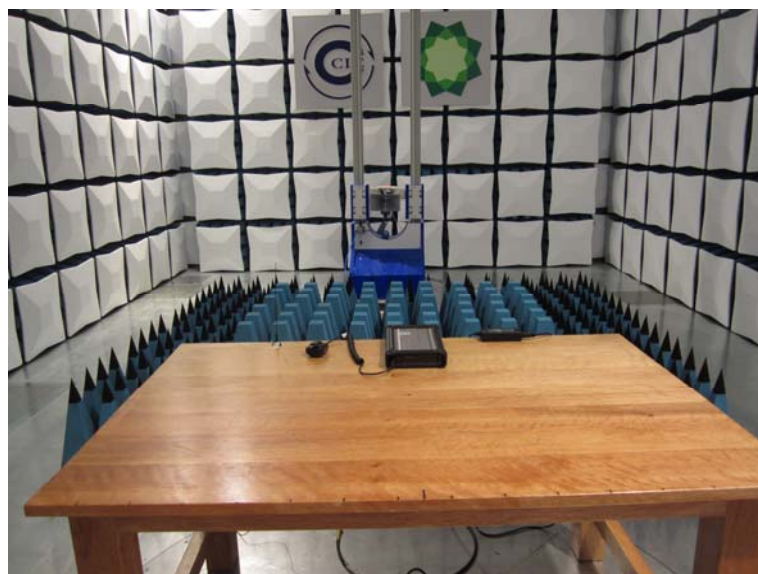

6. External and Internal Photos of the EUT

External photos of the EUT

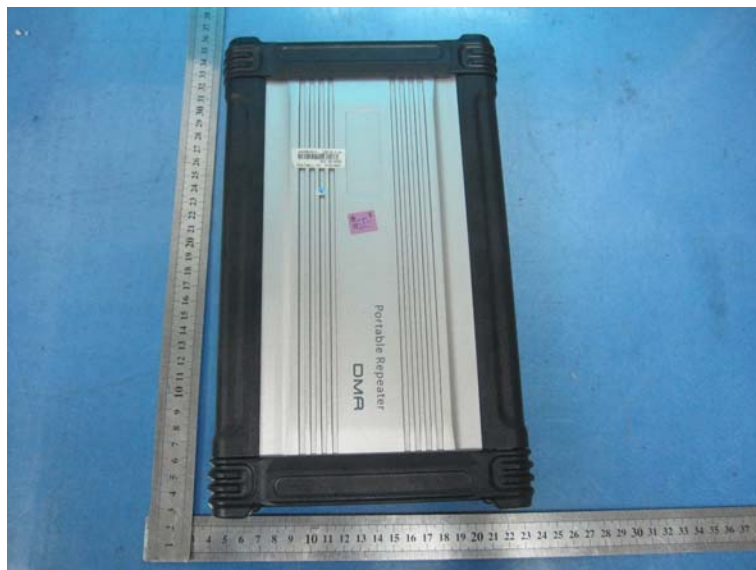





Internal photos of the EUT

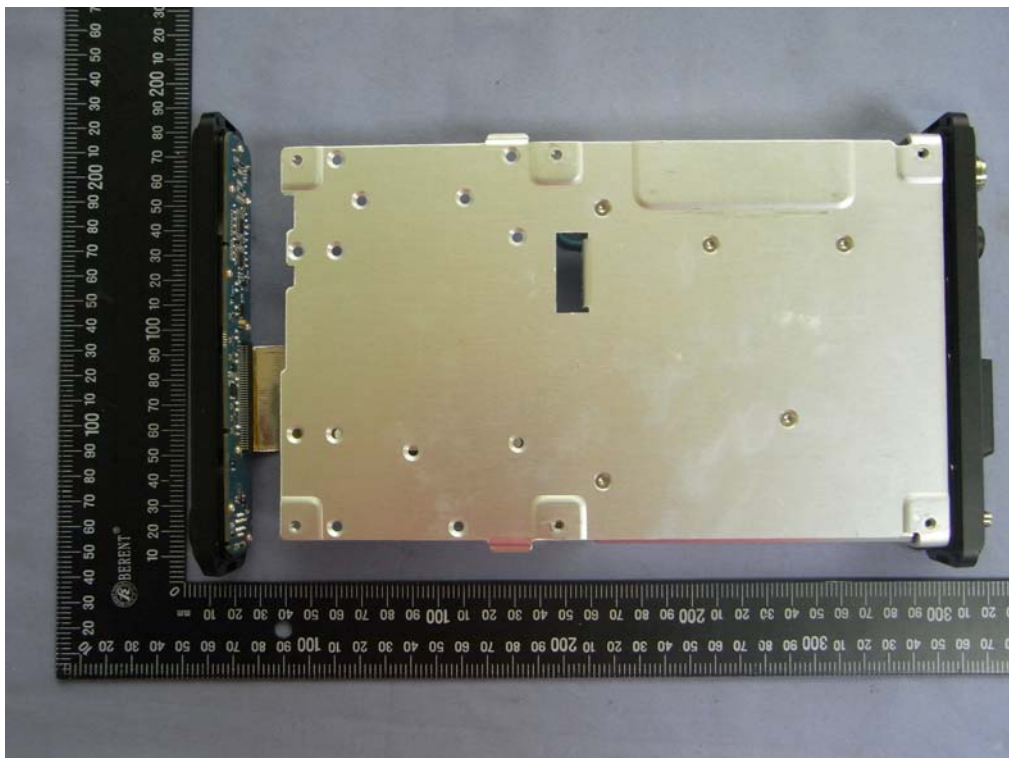
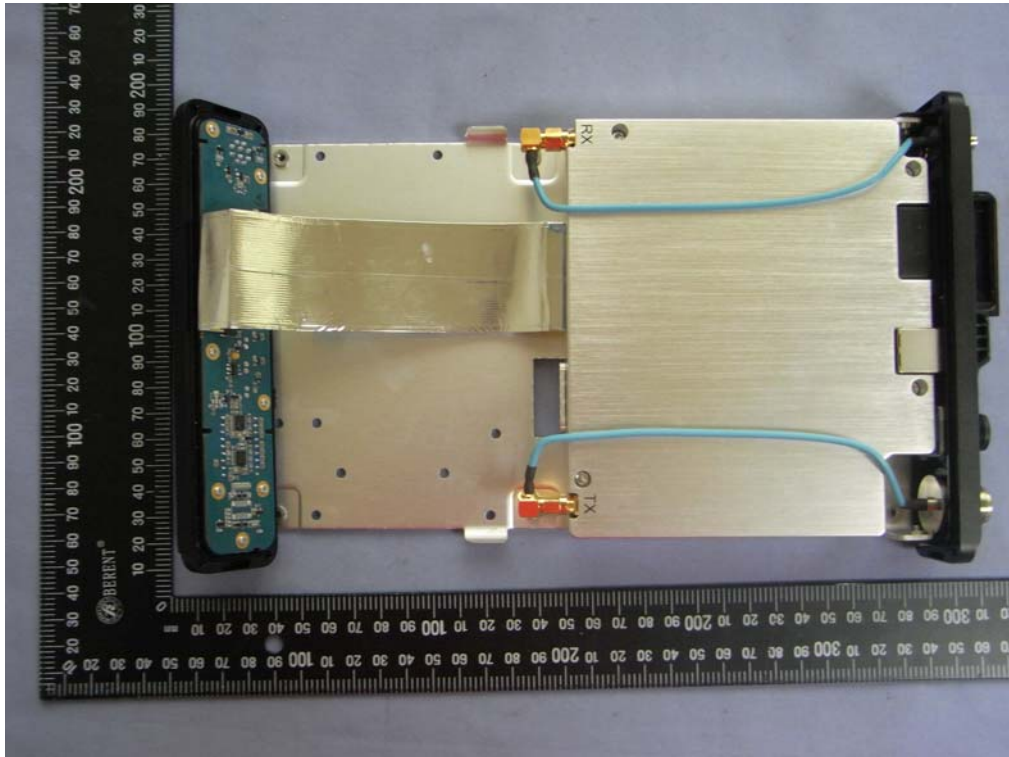

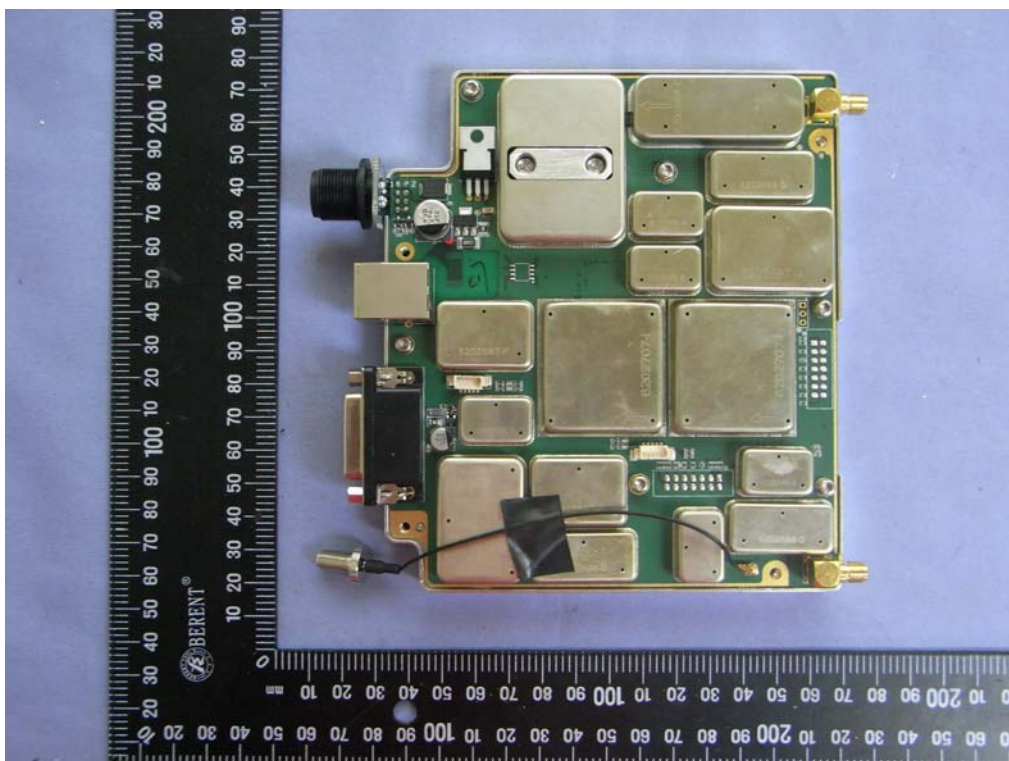
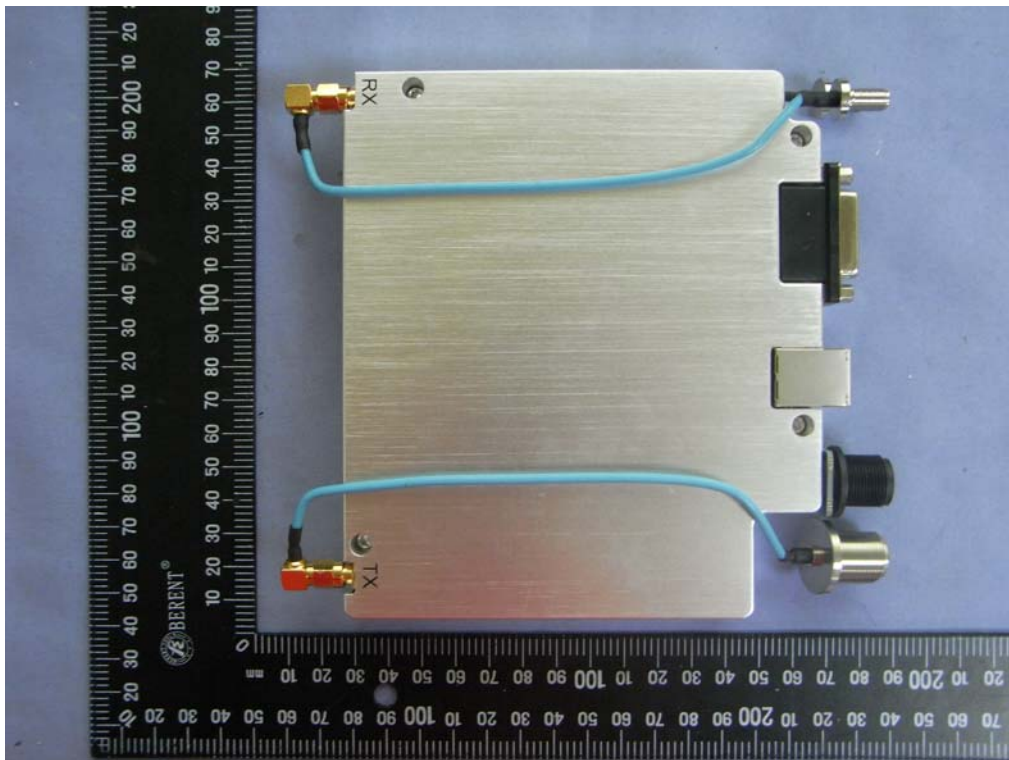

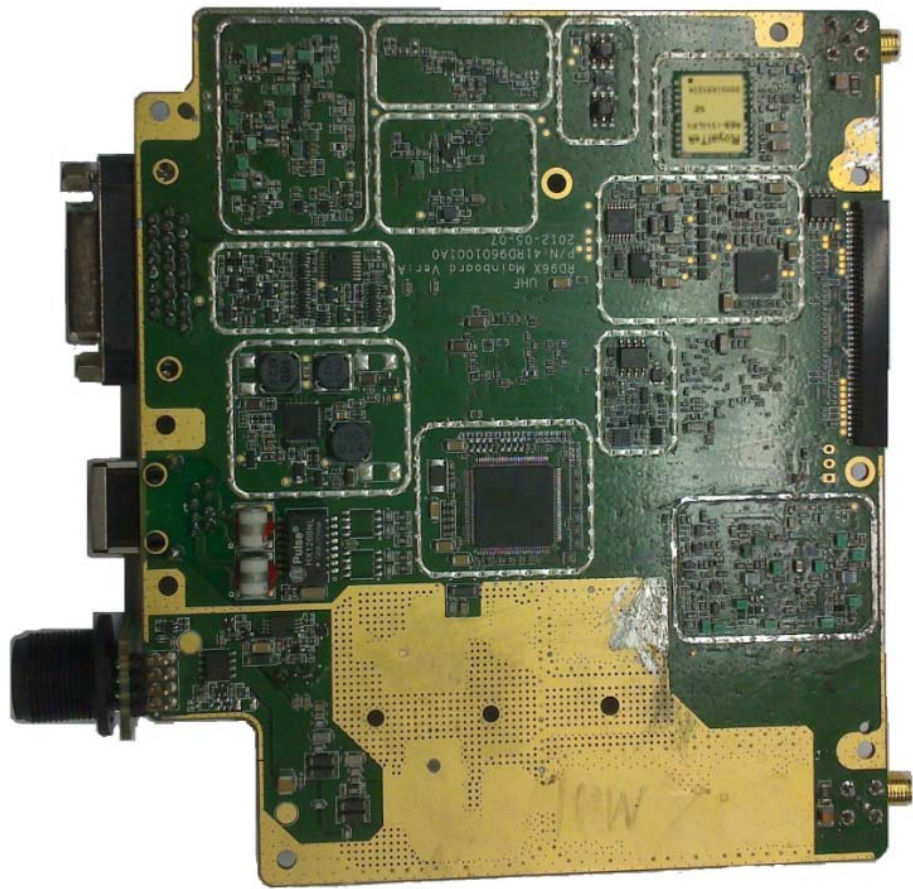
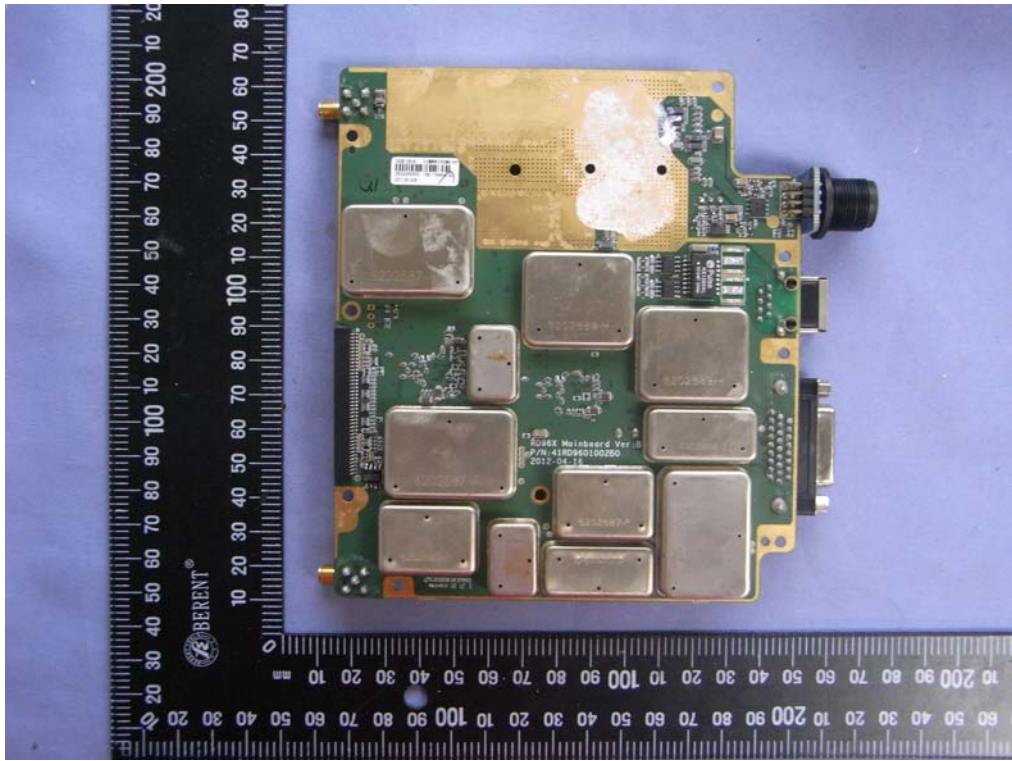

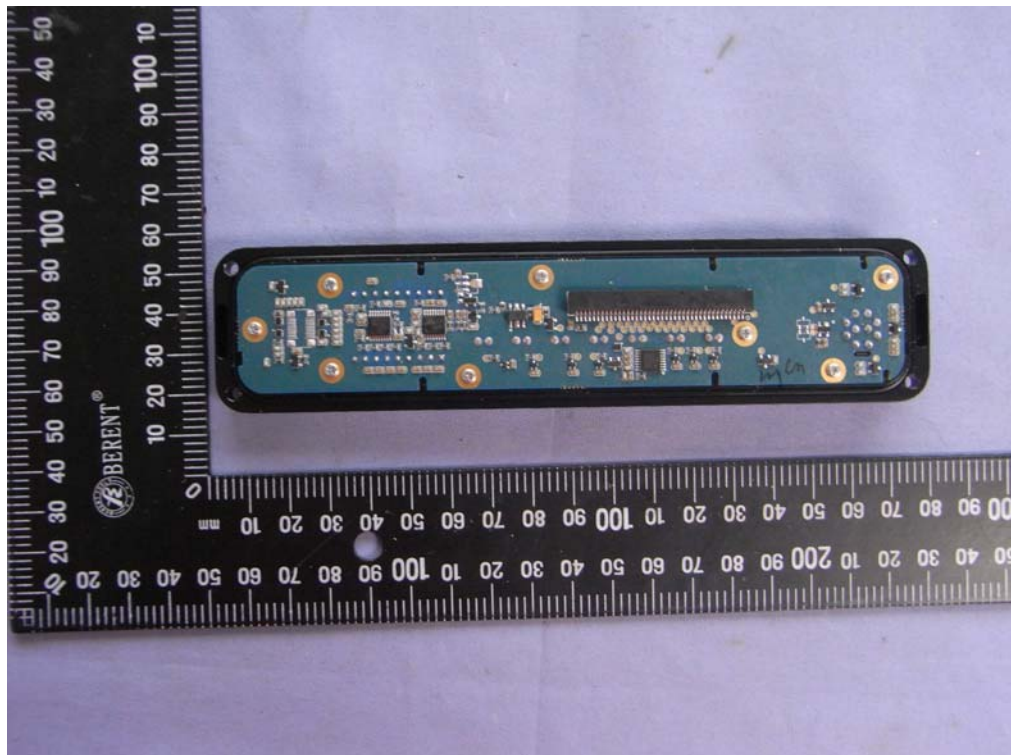
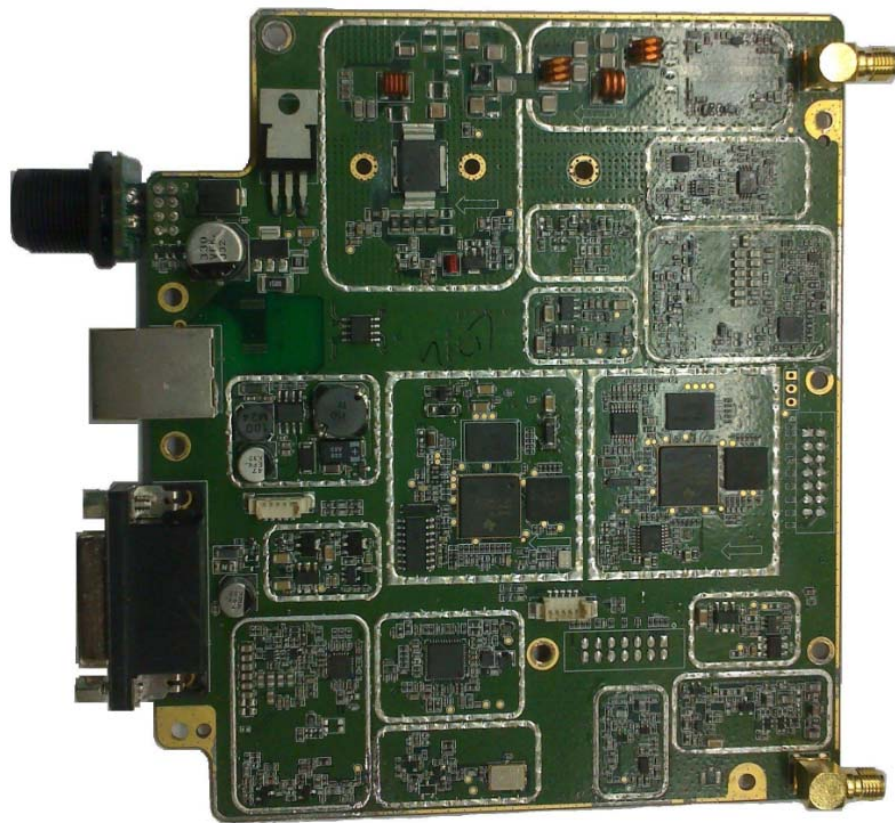

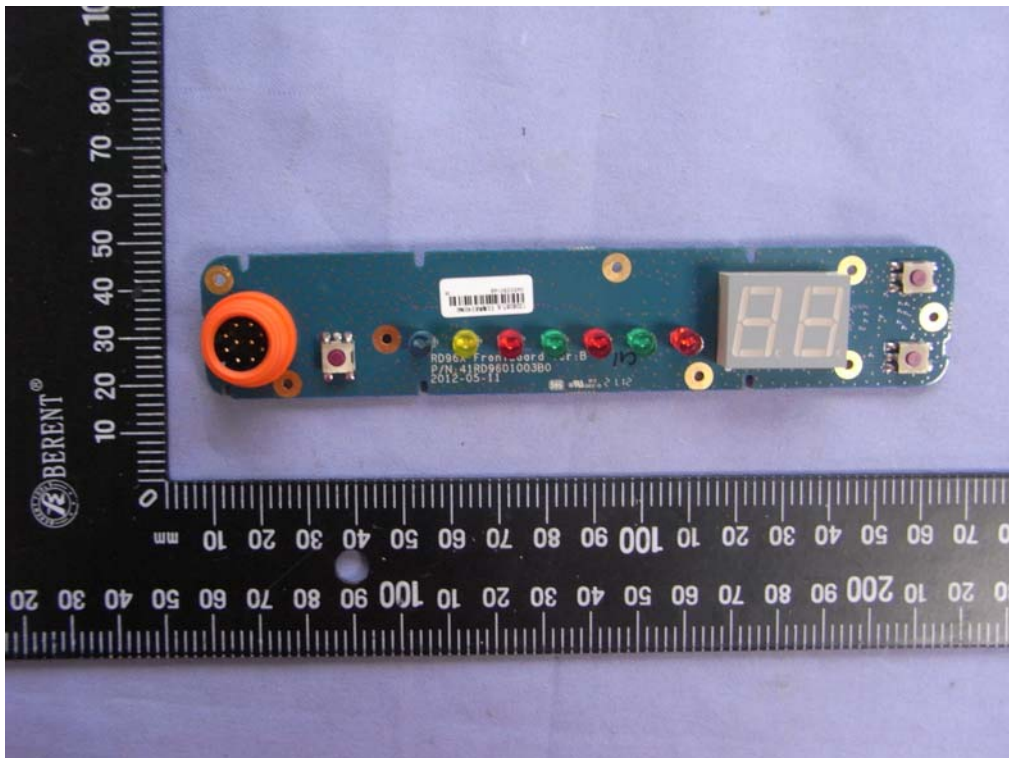
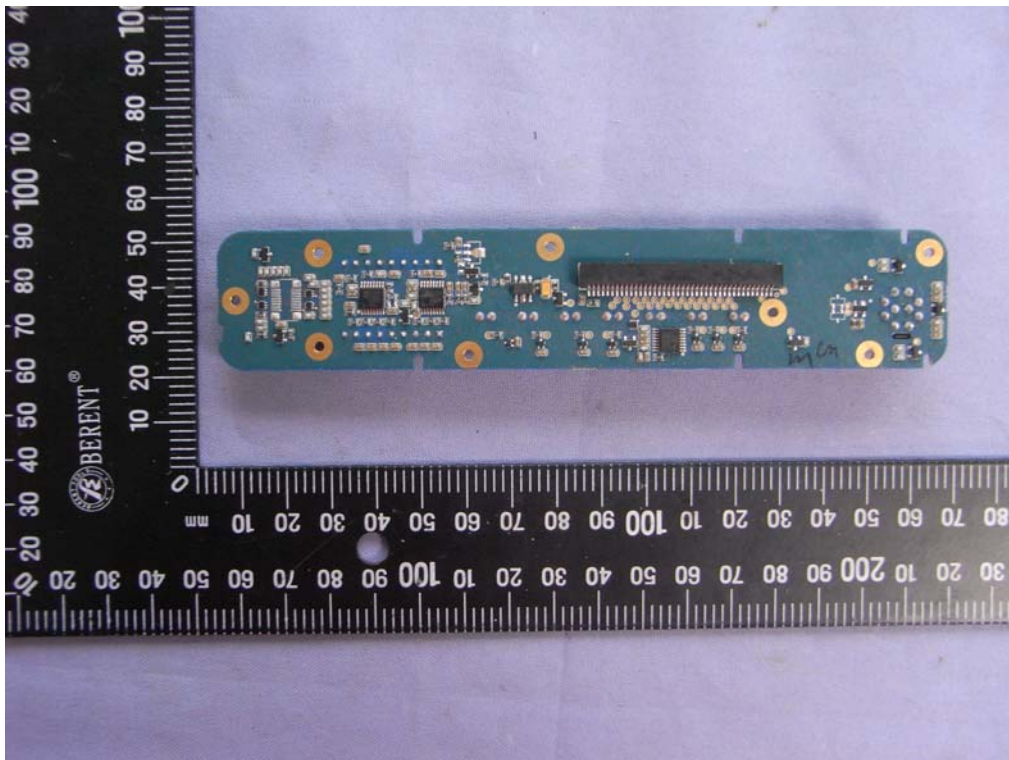

.....End of Report.....